

(19)



(11)

**EP 3 291 878 B1**

(12)

**EUROPEAN PATENT SPECIFICATION**

(45) Date of publication and mention of the grant of the patent:  
**17.07.2024 Bulletin 2024/29**

(51) International Patent Classification (IPC):  
**A61N 1/36** <sup>(2006.01)</sup>      **A61N 1/372** <sup>(2006.01)</sup>  
**A61N 1/378** <sup>(2006.01)</sup>

(21) Application number: **16769480.1**

(52) Cooperative Patent Classification (CPC):  
**A61N 1/36071; A61N 1/0551; A61N 1/36062;**  
**A61N 1/36192; A61N 1/36196; A61N 2/008;**  
**A61N 2/002**

(22) Date of filing: **21.03.2016**

(86) International application number:  
**PCT/US2016/023365**

(87) International publication number:  
**WO 2016/154091 (29.09.2016 Gazette 2016/39)**

---

(54) **APPARATUS FOR MULTIMODAL ELECTRICAL MODULATION OF PAIN**

VORRICHTUNG ZUR MULTIMODALEN ELEKTRISCHEN MODULATION VON SCHMERZEN

APPAREIL DESTINÉ À UNE MODULATION ÉLECTRIQUE MULTIMODALE DE LA DOULEUR

---

(84) Designated Contracting States:  
**AL AT BE BG CH CY CZ DE DK EE ES FI FR GB**  
**GR HR HU IE IS IT LI LT LU LV MC MK MT NL NO**  
**PL PT RO RS SE SI SK SM TR**

- **CEDENO, David Leonardo**  
**Bloomington, IL 61704 (US)**
- **BENYAMIN, Rasmin M.**  
**Bloomington, IL 61704 (US)**

(30) Priority: **20.03.2015 US 201562135999 P**  
**23.07.2015 US 201562196030 P**

(74) Representative: **Zimmermann & Partner**  
**Patentanwälte mbB**  
**Postfach 330 920**  
**80069 München (DE)**

(43) Date of publication of application:  
**14.03.2018 Bulletin 2018/11**

(73) Proprietor: **Medtronic SG, LLC**  
**Minneapolis, MN 55432-5604 (US)**

(56) References cited:  
**WO-A1-95/19804**      **WO-A2-2009/139968**  
**US-A- 5 224 477**      **US-A- 5 224 477**  
**US-A1- 2013 035 745**      **US-A1- 2013 035 745**  
**US-A1- 2014 277 265**      **US-A1- 2014 277 265**  
**US-A1- 2014 330 345**

(72) Inventors:  

- **VALLEJO, Ricardo**  
**Bloomington, IL 61704 (US)**

**EP 3 291 878 B1**

---

Note: Within nine months of the publication of the mention of the grant of the European patent in the European Patent Bulletin, any person may give notice to the European Patent Office of opposition to that patent, in accordance with the Implementing Regulations. Notice of opposition shall not be deemed to have been filed until the opposition fee has been paid. (Art. 99(1) European Patent Convention).

---

**Description**

**Field of the Invention**

5 **[0001]** This disclosure relates to systems and methods for providing multimodal stimulation of neural structures, and, more specifically, for managing pain with either multiple signals or a single signal having modulated characteristics.

**Background of the Invention**

10 **[0002]** The term Spinal Cord Stimulation (SCS) is used to describe an advanced management therapy for chronic pain in which a varying electric field is applied to the Dorsal section of the spinal Cord (DC) via an electrode array (or electrode arrays) implanted in the epidural space. Conventional SCS also called tonic, traditionally utilizes an electric field varying between 40-250 Hz that is directed to a targeted pain location by overlaying it with a perceived tingling sensation, known as paresthesia, created by the stimulating electric field. This therapy has been clinically utilized for  
15 about half a century. The principle mode of action is based on the Gate Control Theory formulated by Melzack and Wall, although a full understanding of the mechanism has yet to be elucidated. The concept behind tonic SCS is that the paresthesia induced by the applied varying electric field masks, or "closes the gates to", pain signals travelling to the brain, however, the relationship between frequency, waveform shape, amplitude and pulse width and the mechanism by which SCS provides an analgesic effect is not fully understood. Documents US 2013/035745 A1 and US 2014/277265  
20 A1 relate to stimulation systems and corresponding methods.

**Summary of the Invention**

25 **[0003]** The invention is defined by the appended claims. Any methods disclosed hereinafter are presented for illustrative purposes only and do not, by themselves, form part of the invention.

**[0004]** Disclosed herein are apparatus and methods for managing pain in a patient by using multimodal stimulation of neural structures, with either multiple signals or a single signal having modulated characteristics. Multimodal modulation for pain management, in accordance with the disclosure, contemplates the use of multiple separate varying or oscillating electromagnetic fields which are independently applied via an array of electrodes (referred as contacts or leads) to a particular neural structure using a variety of temporal and amplitude characteristics, to modulate glial and neuronal interactions as the mechanism for relieving chronic pain. Specifically, disclosed is an apparatus and method for modulating the expression of genes involved in diverse pathways including inflammatory/immune system mediators, ion channels and neurotransmitters, in both the Spinal Cord (SC) and Dorsal Root Ganglion (DRG). In one embodiment, such expression modulation is caused by spinal cord stimulation or peripheral nerve stimulation. In one embodiment, the amplitudes and frequencies of the signal or signals used to create the multimodal stimulation of neural structures may be optimized for improved pain relief and minimal power usage in an implantable multimodal signal generator, as described herein.

30 **[0005]** According to one aspect, the present disclosure provides a method for stimulating/modulating the interaction between glial cells and neurons of a subject comprising: A) exposing glial cells and neurons of the subject to a first stimulus; and B) simultaneously exposing the glial cells and neurons of the subject to a second stimulus; wherein the first stimulus and the second stimulus have at least one uncommon parameter therebetween. In one embodiment, the first stimulus and the second stimulus comprise electrical signals. In another embodiment, the electrical signals have different values for any of their respective frequency, amplitude, phase or waveform shape

35 **[0006]** According to another aspect, the present disclosure provides a method for stimulating and modulating the interaction between glial cells and neurons of a subject comprising: A) exposing glial cells and neurons of the subject to a first stimulus; and B) exposing the glial cells and neurons of the subject to a second stimulus; wherein the first stimulus and the second stimulus have a common parameter therebetween. In one embodiment, the first stimulus comprises a first varying electric field and the second stimulus comprises a second varying electric field. In another embodiment, the first varying electric field and the second varying electric field are provided by a composite electrical signal. In still another embodiment, the composite electrical signal may be any of an amplitude modulated, frequency modulated, summation, or pulse width modulated signal.

40 **[0007]** According to another aspect, the present disclosure provides a method for stimulating and modulating the interaction between glial cells and neurons of a subject comprising: A) exposing glial cells and neurons of the subject to a first stimulus; and B) simultaneously exposing the glial cells and neurons of the subject to a second stimulus; wherein the first stimulus and the second stimulus have a common parameter therebetween. In one embodiment, the first stimulus and the second stimulus comprise electrical signals having substantially the same of any of amplitudes, frequencies, phases, or waveform shapes.

45 **[0008]** According to yet another aspect, the present disclosure provides a method for stimulating and modulating the

interaction between glial cells and neurons of a subject comprising: A) providing lead arrays having a plurality of electrode contacts electrically coupleable to an electrical signal source; B) electrically coupling a first subgroup of the plurality of electrode contacts to a first electrical signal source; C) electrically coupling a second subgroup of the plurality of electrode contacts to a second electrical signal source; D) exposing glial cells and neurons of the subject to the first electrical signal from the first subgroup of electrode contacts; and E) simultaneously exposing the glial cells and neurons of the subject to the second electrical signal from the second subgroup of electrode contacts.

**[0009]** According to still another aspect, the present disclosure provides a method for managing pain in a subject comprising: A) activating glial cells by regulating any of genes for calcium binding proteins, cytokines, cell adhesion or specific immune response proteins without the administration of a pharmacological compound to the subject. In one embodiment, activating the glial cells comprises exposing the glial cells to a first stimulus which may be a varying electromagnetic field. In another embodiment, activating the glial cells comprises exposing the glial cells to a second stimulus, substantially simultaneously with the first stimulus, wherein the second stimulus comprises a second varying electromagnetic field. In still another embodiment, the first and second varying electromagnetic fields have one of different frequency, amplitude, phase, or harmonic content.

**[0010]** According to yet another aspect, the present disclosure provides a method for managing pain in a subject comprising: A) lowering a threshold for depolarization of nerve fibers in the subject with a first varying electromagnetic field; and B) simultaneously activating glial cells with a second varying electromagnetic field; without the administration of a pharmacological compound to the subject. In one embodiment, the first varying electromagnetic field and the second varying electromagnetic field have any of different respective frequencies, amplitudes, phases or harmonic content. In another embodiment, the first and second varying electromagnetic fields may be provided by either a single electrical signal or by two different electrical signals.

**[0011]** According to still another aspect, a method for managing pain in a subject comprises: A) lowering a threshold for depolarization of nerve fibers in the subject with a first varying electromagnetic field for a first period of time; and B) simultaneously modulating glial cell activity with a second varying electromagnetic field during a second period of time not identical to the first period of time causing down-regulation of calcium binding protein (cabp1) within the modulated glial cell.

**[0012]** According to yet another aspect, a method for managing pain in a subject comprises: A) lowering a threshold for depolarization of nerve fibers in the subject with a first varying electromagnetic field for a first period of time; and B) simultaneously modulating glial cell activity with a second varying electromagnetic field during a second period of time not identical to the first period of time causing up-regulation of any of Toll-like receptor 2 (tlr2), Chemokine cxcl16, and Glial maturation factor (Gmfg) within the modulated glial cells.

**[0013]** According to still another aspect, a method for managing pain in a subject comprises: A) lowering a threshold for depolarization of nerve fibers in the subject with a first varying electromagnetic field for a first period of time; and B) simultaneously modulating glial cell activity with a second varying electromagnetic field during a second period of time not identical to the first period of time; wherein the varying electromagnetic fields change synaptic plasticity of neurons and glial cells within the neural structures.

**[0014]** According to yet another aspect, a method for managing pain in a subject comprises: A) lowering a threshold for depolarization of nerve fibers in the subject with a first varying electromagnetic field for a first period of time; and B) simultaneously modulating glial cell activity with a second varying electromagnetic field during a second period of time not identical to the first period of time; wherein the first varying electromagnetic field is provided by an electric signal having an amplitude set to a value corresponding to a percentage of a Priming Perception Threshold (PPT) of the subject, and wherein a second varying electromagnetic field is provided by an electric signal having an amplitude set to a value corresponding to a percentage of the paresthesia threshold (PT).

**[0015]** In one embodiment of multimodal modulation therapy, the priming signal may be monophasic, or biphasic, in which the polarity of the first phase of the biphasic priming signal may be either cathodic or anodic. With this embodiment, the tonic signal may have waveform characteristics that are different from those of the priming signal. The tonic signal may be either monophasic, or biphasic, with the polarity of the first phase of the biphasic tonic signal being either cathodic or anodic. Biphasic stimulation increases the amount of genes related to glial activation (tlr2 and cxcl16) relative to anodic and cathodic stimulation while monophasic cathodic stimulation causes the release of glutamate from astrocytes. Biphasic stimulation increases the amount of cabp1 relative to monophasic stimulation (cathodic or anodic). Monophasic stimulation (cathodic or anodic) and biphasic stimulation affect similarly the amount of the immune-related gene cd 68 and the expression of the gene coding for the opioid receptor oprm1.

**[0016]** According to one aspect, the present disclosure provides a method for stimulating/modulating the interaction between glial cells and neurons of a subject comprising: A) exposing glial cells and neurons of the subject to a first stimulus; and B) simultaneously exposing the glial cells and neurons of the subject to a second stimulus; wherein the first stimulus and the second stimulus have different respective phase polarities. In one embodiment, the first stimulus and the second stimulus comprise electrical signals. In another embodiment, the electrical signals have different values for any of their respective frequency, amplitude, waveform shape, or width in the case of rectangular waveforms.

5 [0017] According to another aspect, the present disclosure provides a method for stimulating and modulating the interaction between glial cells and neurons of a subject comprising: A) providing lead arrays having a plurality of electrode contacts electrically coupleable to an electrical signal source; B) electrically coupling a first subgroup of the plurality of electrode contacts to a first electrical signal source; C) electrically coupling a second subgroup of the plurality of electrode contacts to a second electrical signal source; D) exposing glial cells and neurons of the subject to the first electrical signal from the first subgroup of electrode contacts; and E) simultaneously exposing the glial cells and neurons of the subject to the second electrical signal from the second subgroup of electrode contacts wherein the first electrical signal and the second electrical signal have different respective phase characteristics.

10 [0018] According to still another aspect, the present disclosure provides a method for managing pain in a subject comprising: A) activating glial cells during a first time period by regulating any of genes for calcium binding proteins, cytokines, cell adhesion or specific immune response proteins; and B) administering a pharmacological substance to the subject during a second time period not identical to the first time. In one embodiment, such a pharmacological substance suitable for use with the disclosed method may comprise a metabotropic or ionotropic glutamate receptor antagonist such as (S)-4-carboxyphenylglycine (CPG), (RS)- $\alpha$ -methyl-4-carboxyphenylglycine (MCPG), or kynurenic acid (KYA). In another embodiment, a suitable pharmacological substance may comprise a potassium channel antagonist, such as 4-aminopyridine (4AP), or an alpha-2 adrenergic receptor agonist, such as clonidine, or a calcium channel agonist such as the  $\omega$ -conotoxin MVIIC. Such pharmacological substances can help to activate or deactivate glial cells by modulating the release of glutamate, potassium or calcium ions in or out the glial cell. In one embodiment, activating the glial cells comprises exposing the glial cells to a first stimulus which may be a varying electromagnetic field. In another embodiment, activating the glial cells comprises exposing the glial cells to a second stimulus, substantially simultaneously with the first stimulus, wherein the second stimulus comprises a second varying electromagnetic field. In still another embodiment, the first and second varying electromagnetic fields have one of different frequency, amplitude, phase polarity, relative phase, harmonic content, or width for rectangular waveforms.

15 [0019] According to yet another aspect, the present disclosure provides a method for managing pain in a subject comprising: A) lowering a threshold for depolarization of nerve fibers in the subject with a first varying electromagnetic field; and B) simultaneously modulating glial cell activity with a second varying electromagnetic field; wherein the electromagnetic fields control the balance of glutamate and glutamine in a calcium dependent manner within the modulated glial cells. In one embodiment, the first varying electromagnetic field and the second varying electromagnetic field have any of different respective frequencies, amplitudes, phases, harmonic content, or width for rectangular waveforms. In another embodiment, the first and second varying electromagnetic fields may be provided by either a single electrical signal or by two different electrical signals.

20 [0020] According to still another aspect, a method for managing pain in a subject comprises: A) lowering a threshold for depolarization of nerve fibers in the subject with a first varying electromagnetic field for a first period of time; and B) simultaneously modulating glial cell activity with a second varying electromagnetic field during a second period of time not identical to the first period of time wherein the characteristics of the varying magnetic fields control any of glial depolarization, release or uptake of ions, and release of glial transmitters by the glial cells.

25 [0021] According to yet another aspect, a method for managing pain in a subject comprises: A) lowering a threshold for depolarization of nerve fibers in the subject with a first varying electromagnetic field for a first period of time; and B) simultaneously modulating glial cell activity with a second varying electromagnetic field during a second period of time not identical to the first period of time, wherein the first varying electromagnetic field is provided by an electric signal having a first phase polarity portion which stimulates glial cells to release glutamate, and wherein a second varying electromagnetic field is provided by the electric signal having a second phase polarity portion which stimulates release of glutamate from astrocytes within the glial cells.

30 [0022] According to still another aspect, a method for managing pain in a subject comprises: A) lowering a threshold for depolarization of nerve fibers in the subject with a first varying electromagnetic field for a first period of time; and B) simultaneously modulating glial cell activity with a second varying electromagnetic field during a second period of time not identical to the first period of time; wherein the manipulation of any of the frequency, amplitude, waveform, width and phase of electrical signal generating the first and second varying electromagnetic fields modulates the behavior of glial cells and interaction thereof with neurons at the synaptic level.

35 [0023] According to yet another aspect, a method for managing pain in a subject comprises: A) modulating glial cells in a subject with a monophasic electromagnetic signal having cathodic polarity thereof selected to stimulate glial cells to release glutamate; and B) modulating glial cells in a subject with a monophasic electromagnetic signal having anodic polarity thereof selected to stimulate glial cells to inhibit the release of glutamate.

40 [0024] According to still another aspect, a method for managing pain in a subject comprises: A) modulating glial cells with an asymmetric biphasic electromagnetic signal having variable duration of the anodic phase thereof selected to modulate the amount of glutamate released therefrom; and B) modulating glial cells with an asymmetric biphasic electromagnetic signal having variable duration of the cathodic phase thereof selected to modulate the amount of glutamate released therefrom.

**[0025]** According to yet another aspect, a method for managing pain in a subject comprises: A) modulating glial cells with an asymmetric biphasic electromagnetic signal having variable duration of the cathodic and anodic phases thereof selected to modulate the amount of glutamate released therefrom, wherein the electromagnetic fields control the balance of glutamate and glutamine in a calcium dependent manner within the modulated glial cells.

**[0026]** According to yet another aspect, a system is provided comprising a signal generation module and one or more leads. The leads are configured for exposing glial cells and neurons simultaneously to a first electromagnetic stimulus and a second electromagnetic stimulus. The signal generation module is configured for having an operating mode for providing a first and a second electric signal having at least one common parameter therebetween or at least one uncommon parameter therebetween to the one or more leads.

**[0027]** Also disclosed herein is an apparatus comprising a signal generation module that is configured for electrically coupling with one or more leads. Coupling of the apparatus with one or more leads may provide the system.

**[0028]** Optionally, the signal generation module comprises at least a first and a second electric signal source or terminal and the one or more leads comprise at least a first and a second subgroup of electrodes. The first subgroup of electrodes can be electrically coupled to the first electric signal source and/or terminal and the second subgroup of electrodes can be electrically coupled to the second electric signal source and/or terminal.

**[0029]** Optionally, the signal generation module is configured for having an operating mode for providing at least first and second electric signals corresponding to the first and second electromagnetic stimulus as described herein. Optionally, the first and second electric signals have a different frequency.

**[0030]** Optionally, the signal generation module is configured for having an operating mode for providing electric signals to the electrodes corresponding to the electromagnetic stimulus of any of the methods described herein.

**[0031]** Optionally, the signal generation module is configured for having an operating mode for providing a Priming signal to the first subgroup of electrodes and, e.g. simultaneously, a Tonic signal to the second subgroup of electrodes, e.g. as described herein. The signal generation module can be configured for having an operating mode for providing a first electric signal having a frequency between 200 Hz to 1,500 Hz to the first subgroup of electrodes, and a second electric signal having a frequency lower than the first electric signal, such as between 20 Hz and 150 Hz, to the second subgroup of electrodes. The signal generation module may be configured for having an operating mode for providing a priming signal and a tonic signal with a ratio of the frequency of the priming signal to the tonic signal in the range of 20:1 to 40:1.

**[0032]** Optionally, the signal generation module is arranged for generating a composite electric signal. The composite electric signal can be a summed signal of the first and second electric signals. Optionally, the signal generation module is arranged for generating a multimodal signal, such as a frequency-modulated signal or an amplitude modulated signal. The composite signal and/or the multimodal signal can be provided to the one or more leads.

**[0033]** Optionally, the signal generation module can be configured for having an operating mode for providing a first electric signal having a frequency to the first subgroup of electrodes, and a second electric signal having the same frequency to the second subgroup of electrodes. The frequency can be between 500 Hz and 1,500 Hz. Other parameters of the first and second electric signals may be different, such as the pulse width and/or amplitude. The first electric signal can be fired synchronously, i.e. simultaneously, with the second electric field, or asynchronously, e.g. with a given time delay, relative to the first electric signal.

**[0034]** As used herein, a signal generation module that is configured for having an operating mode may comprise a memory module containing instructions defining at least an operating mode as described, wherein the operating mode is optionally a user-selectable operating mode and the memory module optionally comprises instructions for additional operating modes. In certain embodiments the signal generation module is configured for delivering electrical signals to one or more leads as specified.

**[0035]** Optionally, the signal generation module comprises two or more electric signal sources, such as signal generators, that are independently controllable, and are configured for delivering electric signals with parameters that can be set separately for each of the electric signal sources.

**[0036]** Optionally, the apparatus is a non-implantable, e.g. trialing, system comprising a signal generation module comprising at least two signal generators configured for delivering electric signals with parameters that can be set separately for each of the signal generators, for example a Priming signal and a Tonic signal.

**[0037]** Optionally, an implantable multimodal generator is provided, that is adapted for electrically coupling with one or more leads, or optionally is coupled with one or more leads. The implantable multimodal generator comprises generator circuitry and a housing. The housing can hermetically seal the generator circuitry and can be made of a durable biocompatible material. The generator has an output interface for establishing electrical connection with electrodes implemented in one or more leads, e.g. a first and second terminal for electrically coupling to a first and second subgroup of electrodes implemented on one or more leads.

**[0038]** Optionally the implantable multimodal generator comprises two or more signal generators and timer electronic circuitry that can slave one of the signal generators to another signal generator, such that a delay can be produced between signals generated from the at least two signal generators.

[0039] According to another aspect of the disclosure, an electromagnetic stimulation device is provided including an output unit for connection to at least one electrode array, or a plurality of arrays of electrodes, and a signal generator, wherein the stimulation device is arranged for providing a multimodal stimulation signal to at least one electrode array, or a plurality of arrays of electrodes via the output unit. The multimodal stimulation signal can be an electromagnetic signal. At least one electrode array is configured for exposing glial cells and neurons to the multimodal stimulation signal. The electromagnetic stimulation device can be a pain treatment device.

[0040] Optionally, the electromagnetic stimulation device may have an output unit that includes a first output for connection to a first lead and a second output for connection to a second lead. The first lead can include a first array of electrodes. The second lead can include a second array of electrodes.

[0041] Optionally, the signal generator is arranged for providing a first electric signal to the first output and a second electric signal to the second output. The first electric signal and the second electric signal can differ in a parameter such as amplitude, frequency, phase, phase polarity, waveform shape, and width. The first electric signal and the second electric signal may correspond in a parameter such as amplitude, frequency, phase, phase polarity, waveform shape, and width. The second electric signal can be a tonic stimulation signal, and the first electric signal can have a frequency higher than the frequency of the tonic stimulation signal.

[0042] Optionally, the signal generator is arranged for generating a multimodal electric signal, such as a frequency modulated signal or an amplitude modulated signal. The multimodal electric signal can be provided to at least one electrode.

[0043] According to another aspect of the disclosure, a method for operating a signal generation module is provided. The method includes connecting the signal generation module to one or more leads. The leads can already have been provided to a body of a subject. The method includes generating, using the signal generation module, a first oscillating electromagnetic field at least one of the one or more leads and generating, using the signal generation module, a second oscillating electromagnetic field at least one of the one or more leads. The first oscillating electromagnetic field and the second oscillating electromagnetic field can have at least one uncommon parameter therebetween.

[0044] According to another aspect of the disclosure, an electrically conducting material is provided, such as a metal, e.g. in the form of an electrode, for use in administering an electromagnetic stimulus into a subject for the treatment of pain. The electromagnetic stimulus can include a first electromagnetic stimulus and a second electromagnetic stimulus. The first stimulus and the second stimulus may have at least one uncommon parameter therebetween. The first stimulus and the second stimulus can be signals, or a composite signal, or multimodal signal as described herein.

[0045] Optionally, the first stimulus is a Priming signal and the second stimulus is a Tonic signal. The first stimulus can have a frequency between 200 Hz to 1,500 Hz. The second stimulus can have a frequency lower than the first stimulus, such as between 20 Hz and 150 Hz. The frequency of the first stimulus and the frequency of the second stimulus can have a ratio in the range of 20:1 to 40:1.

[0046] According to another aspect of the disclosure, an electromagnetic stimulation system comprises a memory for storing a plurality of multimodal signal parameter programs; a selection device for selecting one of the plurality of multimodal signal parameter programs; a multimodal signal generator controllable by a selected of the plurality of multimodal signal parameter programs; and an output unit for connection to at least one electrode; wherein the stimulation device is configured to provide a multimodal stimulation signal generated by the multimodal signal generator in accordance with a selected of the multimodal signal parameter programs to the at least one electrode via the output unit. The system may further comprise an enclosure of biocompatible material surrounding the multimodal signal generator and output unit. In one embodiment, the multimodal signal generator generates a first and second electric signals on in an operational mode thereof. In one embodiment, the system may be combined with at least one electrode comprising at least a first and a second subgroup of electrodes, and wherein the first subgroup of electrodes is electrically coupled to the first electric signal and the second subgroup of electrodes is electrically coupled to the second electric signal.

[0047] It will be appreciated that any of the aspects, features and options described in view of the methods apply equally to the system, signal generation module and stimulation device. It will be understood that any one or more of the above aspects, features and options as described herein can be combined.

### Description the Drawings

[0048] The various features and advantages of the present invention may be more readily understood with reference to the following detailed description taken in conjunction with the accompanying drawings, wherein like reference numerals designate like structural elements, and in which:

Figure 1 is a schematic diagram illustrating an apparatus for pain management in accordance with an embodiment of the present disclosure;

Figure 2 illustrates a schematic circuit diagram of an implantable multimodal modulation device that may be utilized with a system in accordance with an embodiment of the present disclosure;

Figures 3A-B illustrate conceptually electrode arrays that may be utilized with a system in accordance with an embodiment of the present disclosure;

Figure 4 illustrates conceptually a pair of traces representing signals that may be used in an example of prime multimodal modulation in accordance with an embodiment of the present disclosure;

5 Figure 5 illustrates conceptually a pair of traces representing signals that may be used in an example of prime multimodal modulation in accordance with an embodiment of the present disclosure;

Figure 6 illustrates conceptually a pair of traces representing signals that may be used in an example of prime multimodal modulation in accordance with an embodiment of the present disclosure;

10 Figure 7 illustrates conceptually a pair of traces representing signals that may be used in an example of twin multimodal modulation in accordance with an embodiment of the present disclosure;

Figure 8 illustrates conceptually a pair of traces representing signals that may be used in an example of twin multimodal modulation in accordance with an embodiment of the present disclosure;

Figure 9 illustrates conceptually an amplitude modulated signal that may be utilized for multimodal modulation in accordance with an embodiment of the present disclosure;

15 Figure 10 illustrates conceptually a frequency modulated signal, with a carrier frequency larger than the modulating frequency, that may be utilized for multimodal modulation in accordance with an embodiment of the present disclosure;

20 Figure 11 illustrates conceptually a frequency modulated signal, with a carrier frequency smaller than the modulating frequency, that may be utilized for multimodal modulation in accordance with an embodiment of the present disclosure;

Figure 12 illustrates conceptually a dual combined signal, biphasic pulse example, that may be utilized for multimodal modulation in accordance with an embodiment of the present disclosure;

Figure 13 illustrates conceptually a signal with a continually changing frequency that may be utilized for multimodal modulation in accordance with an embodiment of the present disclosure;

25 Figure 14 illustrates conceptually the placement of an implantable system with a human subject in accordance with an embodiment of the present disclosure;

Figure 15 illustrates conceptually the placement of an implantable system with a human subject in accordance with an embodiment of the present disclosure;

30 Figure 16 illustrates conceptually a graph of results achieved in a pre-clinical animal study utilizing systems and methods in accordance with the present disclosure;

Figures 17A-B illustrate conceptually graphs of results achieved in a short time pilot clinical trial period utilizing systems and methods in accordance with the present disclosure;

35 Figure 18 illustrates conceptually a trace representing a signal having a monophasic cathodic rectangular waveform followed by a interphase delay for passive charge balance that may be used in accordance with an embodiment of the present disclosure;

Figure 19 illustrates conceptually a trace representing a signal having a monophasic anodic rectangular waveform followed by a interphase delay for passive charge balance that may be used in accordance with an embodiment of the present disclosure;

40 Figure 20 illustrates conceptually a trace representing a signal having a biphasic symmetric rectangular waveform in which the first phase is cathodic that may be used in accordance with an embodiment of the present disclosure;

Figure 21 illustrates conceptually a trace representing a signal having a biphasic symmetric rectangular waveform in which the first phase is anodic that may be used in accordance with an embodiment of the present disclosure;

45 Figure 22 illustrates conceptually a trace representing a signal having a biphasic asymmetric rectangular waveform in which the first phase is cathodic and the second, anodic phase, is of smaller amplitude and longer width in accordance with an embodiment of the present disclosure;

Figure 23 illustrates conceptually a trace representing a signal having a biphasic asymmetric rectangular waveform in which the first phase is anodic and the second, cathodic phase, is of smaller amplitude and longer width in accordance with an embodiment of the present disclosure;

50 Figure 24 illustrates conceptually a trace representing a signal having a biphasic asymmetric rectangular waveform in which the first phase is cathodic and the second, anodic phase, is of larger amplitude and shorter width in accordance with an embodiment of the present disclosure;

Figure 25 illustrates conceptually a trace representing a signal having a biphasic asymmetric rectangular waveform in which the first phase is anodic and the second, cathodic phase, is of larger amplitude and shorter width in accordance with an embodiment of the present disclosure;

55 Figure 26 illustrates conceptually a trace representing a signal having a biphasic asymmetric rectangular waveform in which the first phase is cathodic and the second, anodic phase, is of the same width and smaller amplitude;

Figure 27 illustrates conceptually a trace representing a signal having a biphasic asymmetric rectangular waveform in which the first phase is anodic and the second, cathodic phase, is of the same width and smaller amplitude in

accordance with an embodiment of the present disclosure;

Figure 28 illustrates conceptually a trace representing a signal having a biphasic asymmetric rectangular waveform in which the first phase is cathodic and the second, anodic phase, is of the same width and larger amplitude in accordance with an embodiment of the present disclosure;

Figure 29 illustrates conceptually a trace representing a signal having a biphasic asymmetric rectangular waveform in which the first phase is anodic and the second, cathodic phase, is of the same width and larger amplitude in accordance with an embodiment of the present disclosure;

Figure 30 illustrates conceptually a trace representing a signal having a biphasic asymmetric waveform in which the first phase is cathodic rectangular and the second, anodic phase, corresponds to a capacitive-coupled recovery to baseline in accordance with an embodiment of the present disclosure;

Figure 31 illustrates conceptually a trace representing a biphasic asymmetric waveform in which the first phase is anodic and rectangular and the second, cathodic phase, corresponds to a capacitive-coupled recovery to baseline in accordance with an embodiment of the present disclosure; and

Figures 32(a)-(e) illustrate conceptually graphs of experimental results indicating how the polarity of the stimulating electromagnetic field signal influences gene expression.

### Detailed Description

**[0049]** The present disclosure will be more completely understood through the following description, which should be read in conjunction with the drawings. In this description, like numbers refer to similar elements within various embodiments of the present disclosure. The skilled artisan will readily appreciate that the methods, apparatus and systems described herein are merely exemplary and that variations can be made.

**[0050]** The oscillatory electromagnetic fields applied to neural structures induce changes in synaptic plasticity upon modulation of two different cell populations: Neurons and glial cells. This is concurrent with the well-known effects on neurons such as action potential generation or blockade by the stimulation of mechanosensitive fibers to mask (or close the gate to) nociceptive signals travelling to the brain. As such, paresthesia is a byproduct and not a prerequisite to attain pain relief during conventional electrical stimulation. In addition, glial cells are immunocompetent cells that constitute the most common cell population in the nervous system and play a fundamental role in the development and maintenance of chronic neuropathic pain. Glial cells are responsible for monitoring the status of the nervous system by using constant chemical communication with neurons and other glial cells. Microglia are the glial cells in charge of monitoring the brain and spinal cord. Following a nerve (or brain) injury, these cells become activated and respond to any stimulus that is considered a threat to Central Nervous System (CNS) homeostasis. This activation involves morphological changes in the microglia accompanied by changes in chemotaxis and phagocytic activity, as well as the release of chemokines and cytokines that induce a response from the immune system. It has been shown that microglia are the CNS immediate responders to injury. Injury also triggers the activation of astrocytes, glial cells that monitor the synaptic clefts and thus are involved in synaptic plasticity via the regulation of neuro and glial transmitter molecules and involvement of immune cells for synaptic pruning. Astrocyte activation and regulation is sustained for longer time and thus it can be hypothesized that astrocytes play an important role in changes affecting synaptic plasticity in chronic pain. There is experimental evidence that supports this hypothesis. It is worth noting that at the Peripheral Nervous System (PNS), oligodendrocytes, Schwann cells and satellite glial cells, similar to astroglia, play similar roles.

**[0051]** Calcium ions and phosphorylating processes mediated by ATP play an important role in glial response to injury. Electrical impulses induce changes in the concentration of calcium ions in the astrocytes, which propagates between astrocytes via calcium waves. This, in turn, signals the release of transmitters such as glutamate, adenosine and ATP, even after sodium channel blockade, which modulates both neuronal excitability and synaptic transmission. The presence of an external oscillatory electrical field then provides a stimulus for glial cells to affect synapses that have been negatively affected by injury. The electrical field provides a priming response that moves the function of the synapse towards a normal state.

**[0052]** It is possible to electrically stimulate glial cells as their response (glial depolarization, release/uptake on ions, release of glial transmitters) depends on the specific parameters such as amplitude, frequency, phase polarity, waveform shape, and width (in the case of rectangular waveforms) of the stimulation. For example, the release of glutamate from astrocytes may be modulated in proportion to the amount of anodic current administered during biphasic pulsed stimulation. Monophasic cathodic stimulation of hippocampal astrocytes promotes the release of glutamate. The introduction of an anodic component decreases the amount of glutamate released. Given that the glial cells and neurons respond differently to electrical fields, it is then possible to differentially modulate the response of these cell populations with distinctively different electrical parameters. This theory sets the mechanistic basis of multimodal stimulation. Subthreshold stimulation with an electromagnetic field set at an optimum frequency, amplitude, waveform, width and phase may modulate the behavior of glial cells and the way they interact with neurons at the synaptic level. Thus, multimodal modulation provides the ability to control the balance of glutamate and glutamine in a calcium dependent manner and



the possibility of modulating such balance in the appropriate manner with electromagnetic fields.

[0053] Electromagnetic fields modulate the expression of genes and proteins, which are involved in many processes involving synaptic plasticity, neuroprotection, neurogenesis, inflammation. A full genome analysis of the ipsilateral DC and DRG obtained from an animal model of chronic neuropathic pain, in which SCS was applied continuously for 72 hours provided findings that were used to develop the multimodal methodologies described below. The results indicate that the analgesic effect may be induced at the molecular level in addition to, or independently of, the electric field blocking or masking nerve signaling. For example, SCS upregulates genes for calcium binding proteins (cabp), cytokines (tnf, il6, il1b, cxcl16, ifg), cell adhesion (itgb) and specific immune response proteins (cd68, tlr2) which are linked to glial activation. Modulation parameters, particularly the oscillation frequency and amplitude, may play an important role in the mode of action.

### Multimodal Modulation Methodology

[0054] According to one aspect of the disclosure, a method for multimodal modulation, referred to as "prime" modulation utilizes electrode arrays, with some of the electrodes configured to deliver an electric field oscillating at a frequency higher than that typically used in tonic stimulation. The electrical field of this priming signal provides a persistent electrochemical potential that facilitates the stimulation of nerves by another field that is oscillating at a lower frequency. The priming signal lowers the threshold for depolarization of nerve fibers while simultaneously modulating glial activation. The priming signal also lowers the impedance of the stimulated tissue, which allows for better penetration of the electric field into the neural tissue. The frequent pulsing of the priming signal also contributes to a lower threshold for depolarization of nerve fibers via membrane integration of the electrical stimulus. Additionally, the priming signal contributes to neuronal desynchronization which is a mechanism that helps with the reestablishment of neuronal circuits that have been unnaturally synchronized to maintain a nociceptive input into the brain. In the disclosed prime multimodal modulation technique, a mechanism of depolarization is combined with amplitudes lower or slightly higher than the Paresthesia Threshold (PT), so the patient may or may not experience tingling even though tonic stimulation is being applied. A priming signal provides electrical stimulation at frequencies which will activate the molecular mechanisms that allow for resetting of the synaptic plasticity to a state closer to the one previous to central sensitization induced by injury, thus providing a mechanism for long lasting pain relief. The Priming Frequency (PF) may be set to any frequency below 1,500 Hz, but above the tonic frequency. In one embodiment, the PF may be set to any frequency between 200 Hz to 1,500 Hz. When a charged-balanced pulsed rectangular electrical signal, e.g. biphasic symmetric, biphasic asymmetric, capacitor coupled monophasic, is used, the Pulse Width (PW) may be set as low as 10  $\mu$ s and as large as allowed by the priming frequency. For example, the maximum PW for a biphasic signal with equal PW per phase and a 20  $\mu$ s interphase delay is 395  $\mu$ s for PF = 1,200 Hz or 980  $\mu$ s for PF = 500 Hz. Either a voltage or current controlled signal may be used, although a current controlled signal may be more desirable as such signal does not depend on temporal impedance variations in the tissue being stimulated. The amplitude of the priming field may be preferably set at a value below a Priming Perception Threshold (PPT), although setting it at or above the PPT is not excluded. The PPT may be found by slowly increasing the amplitude while feedback is obtained from the subject. Once the onset of perception is recorded, then the amplitude of the priming signal may be changed to a value which is a percentage of the PPT (% PPT). With an exemplary PF of 1500 Hz, the signal may be then set for a given time, e.g. 10-30 minutes, before an electric field set at a tonic frequency lower than the PF, e.g. 10 Hz to 1,499 Hz, is applied independently to other electrodes in the lead. In one embodiment, with an exemplary PF of 200 Hz, the tonic frequency may be in the range of approximately 10 Hz to 199 Hz, for example. In the prime mode of stimulation, the tonic frequency will be lower than the priming frequency but is not necessarily limited to a particular range of frequencies below the prime frequency. The Pulse Width (PW) of a charged-balance, e.g. a biphasic symmetric, biphasic asymmetric, or capacitor coupled monophasic, pulsed signal can be as low as 10  $\mu$ s and as large as allowed by the set tonic frequency. This PW is set to provide a low duty cycle, which will minimize potential field interference between this field and the priming field, especially in electrode arrangements that are spatially proximal. Spatial interference of the fields can also be reduced by including an electronic component in the circuitry that can time the delivery of the tonic signal relative to the priming signal. For example, the priming and tonic signals can be delivered synchronously or asynchronously with a delay therebetween. The signal generation and delivery circuitry may also allow for modifying the duty cycles of pulsed width signals and various schemes in which the time of initial priming can be varied, as well as the times in which the priming signal is on or off relative to the time when tonic signal is delivered. The amplitude of the tonic electric field, which could be either voltage or current controlled, may be set above, below or at the paresthesia or perception threshold (PT). PT may be obtained by increasing the amplitude of the signal while getting feedback from the patient. The tonic amplitude may then be set to a value corresponding to a percentage of the PT (%PT). In the prime multimodal modulation methods described herein both the priming signal and the tonic signal may be below 1,500 Hz, in one embodiment. In another embodiment, the tonic signal may be below 500 Hz. In still another embodiment, the tonic signal may be below 100 Hz. In one embodiment, the ratio of priming signal frequency to tonic signal frequency may be in the range of 20:1 to 40:1, depending on the specific values of the frequencies chosen.

**[0055]** In yet another embodiment of multimodal modulation therapy, the priming signal may be monophasic, as illustrated in Figures 18 or 19, or biphasic, as illustrated in Figures 20 - 31, in which the polarity of the first phase of the biphasic prime signal may be either cathodic or anodic. With this embodiment, the tonic signal may have waveform characteristics that are different from those of the priming signal. The tonic signal may be either monophasic, as illustrated in Figures 18 or 19, or biphasic, as illustrated in Figures 20 - 31, with the polarity of the first phase of the biphasic tonic signal being either cathodic or anodic.

**[0056]** According to another aspect of the disclosure, a method for multimodal stimulation, referred to as "twin" stimulation utilizes two fields that are oscillating at the same frequency (F), which may be set to a value larger than used conventionally. The rationale is similar to the one used in the priming scheme, except that a frequency between 500 Hz and 1,500 Hz, for example, is used for both signals. In this case, the likelihood of stimulation via depolarization and gating is decreased. In a typical application some contacts in the electrode may be set to deliver charge-balanced, e.g. biphasic symmetric, biphasic asymmetric, capacitor coupled monophasic, pulses at a rate of between 1,200 Hz to 1,500 Hz, for example, and PW for each phase set in between 10  $\mu$ s and a value defined by the frequency of the oscillation and the delay between phase changes. For example, for F = 1,200 Hz and a delay of 10  $\mu$ s, the maximum PW is 395  $\mu$ s. The current or voltage amplitude required for perception threshold (PT) is determined and then the electrical signal delivered to the stimulator may be set above, below or at this value (% PT). The other contacts may be set to deliver a field of the same frequency, but PW and amplitude could be different, keeping in mind that the PW may be limited by frequency and the delay between phase changes. The second twin field could be fired synchronously, i.e. simultaneously, with the first twin field, or asynchronously, e.g. with a given time delay, relative to the first twin field.

**[0057]** The techniques disclosed herein may be achieved with minimally invasive procedures which are preferred over those that require extensive surgical intervention and healthcare expenses although in particular circumstances, a surgical implantation may be required. Electrical stimulation leads, similar to those illustrated in Figures 3A - B, can be used, but other designs having a different number of electrodes, size of the electrical contact, spacing between contacts, and geometrical arrangement of electrodes within an array may be utilized. In an embodiment, a lead comprises a cylindrical arrangement of multiple electrodes, e.g. between 4 and 16. The diameter of the lead may be small enough to allow for percutaneous implantation into the spinal canal using an epidural needle under standard clinical practice. The electrodes are made of biocompatible materials such as iridium-platinum alloys which are also resistant to corrosion. For example, a 50 cm long lead implemented with eight electrodes may have a diameter of 1.35 mm, with each cylindrical electrode having a length of 3.0 mm, and a spacing between electrodes of 4.0 mm. Conducting wires may run from the electrodes to the distal part of the lead into metal connectors. The wires may be enclosed within a triple-insulated containment made of a biocompatible durable polymer.

**[0058]** In the case of multimodal modulation of the spinal cord, various multi-contact leads can be positioned in the epidural space to stimulate the cell populations already described. In one particular arrangement, the leads can be positioned parallel to each other. Figure 3A illustrates two eight-contact electrode arrays that can be used for the disclosed multimodal modulation techniques. Electrode contacts numbered 1-4 and 9-12 (using a traditional numbering of electrode contacts), located at the top (rostral) region may be used to deliver tonic pulses in the multimodal prime scheme, while eight electrode contacts at the bottom (caudal) numbered 5-8 and 13-16 may be used to deliver the priming pulses. Note that the polarity of the leads can also be customized during the programming stage, either as bipolar, monopolar, or guarded cathode configurations. Another example of a possible electrode array arrangement is shown in Figure 3B, in which the tonic electric field is surrounded by the electric field of the priming signal, allowing for priming of a larger section and tonic delivery in a smaller region. In another example, each individual electrode array could be set to deliver the electric fields parallel to each other.

**[0059]** Other arrangements may be used to stimulate different places along the spinal canal, e.g. the leads do not need to be parallel. For example, in one arrangement, one lead can be dedicated to deliver a signal (prime or twin) at the spinal cord at a given vertebral level, while the other provides a signal either more caudad or cephalad relative to the position of the other lead. Leads can be in principle located at any vertebral level in the spinal cord, or could also be positioned peripherally, because the principle behind multimodal modulation applies to peripheral glial cells that survey the axons.

## Systems Components

**[0060]** Figure 1 illustrates conceptually an embodiment of a non-implantable trialing system that may be utilized to perform the methods disclosed herein. The system comprises a pair of electrical leads 30 and 32, each of which may be implemented with an array of electrode contacts, a breakout box 18 and signal generators 17 and 19, as illustrated. Breakout box 18 is electrically coupled to leads 30 and 32 and signal generators 17 and 19 through appropriate connectors. The breakout box 18 and signal generators 17 and 19 may be placed in an enclosure referred to as an External Trial Stimulator (ETS) system 16. Each of generators 17 and 19 deliver a particular signal with parameters that can be set separately for each other. Each of generators 17 and 19 may have the functional characteristics and architecture elements

similar to generator 20 described herein without an exterior enclosure suitable for implantation into a patient. In one embodiment, system 16 may also include one or more of the modules described herein with reference to Implantable Multimodal Generator 20 and Figure 2.

**[0061]** The ETS system 16 is electrically coupled to electrical leads, each of which may be implemented with an array of electrode contacts. In an embodiment, a pair of leads 30 and 32 is coupled to the ETS 16 using appropriate connectors as illustrated in Figure 1. In another embodiment, a single lead implemented with an array of electrodes can be used. In a configuration for performing prime multimodal modulation, one of generators 17 or 19 may be configured to deliver a priming signal, for example 1,200 Hz, and the other generator may be configured to deliver a tonic signal, e.g. at 50 Hz. The breakout box 18 may be used to reconfigure the delivery of signals to the proper electrode contacts in leads 30 and 32. In the embodiment illustrated in Figure 1, the electrode contacts 1-8 in electrode array 30 can be split such that electrode contacts 1-4 deliver a first signal, e.g. a tonic signal, different than a second signal delivered at electrode contacts 5-8 thereof, e.g. a priming signal. Similarly, electrode contacts 9-16 of electrode array 32 may be split such that electrode contacts 9-12 thereof deliver a signal similar to that delivered by electrode contacts 1-4 in electrode array 30, while electrode contacts 13-16 thereof deliver a signal similar to that delivered at electrode contacts 5-8 in electrode array 30, as illustrated. In other embodiments either the tonic signal or the priming signal may be sent to any other combination of electrode contacts.

### Implantable Multimodal Generator

**[0062]** Figure 2 illustrates conceptually a block diagram of the elements comprising an Implantable Multimodal Generator (IMG) 20. The generator circuitry may be hermetically sealed in a housing made of a durable biocompatible material, such as stainless steel or titanium. The generator 20 has an output interface for establishing electrical connection with arrays of electrodes implemented within the previously described leads 30 and 32 that deliver the multimodal signals to glial cells and neurons. In one embodiment, the implantable multimodal generator 20 comprises a central processing module 25, a memory module 28, a telemetry module 26, a power source module 21, signal generator module 23, signal generator module 24, and a Breakout and Delay module 22, including the output interfaces thereof.

**[0063]** The central processing module 25 may be implemented with a microprocessor integrated circuit or may comprise reduced functionality small-scale logic, but, in either implementation includes a wireless transceiver functionality that enables bidirectional wireless communication of information with an external programmer unit (not shown) or a user-controlled remote 36.

**[0064]** The memory module 28, which may be implemented with either RAM or ROM memory, may be used to store a modulation program, executable by central processing module 25, which generates functional information of the generator 20. The central processing module 25 is able to store and retrieve information from a memory module 28 as commanded by the user.

**[0065]** The telemetry module 26 is used to communicate via a wireless protocol with the external programmer unit (or control remote) and includes transceiver circuitry in order to conduct wireless communications with devices remote from generator 20 according to any number of established wireless protocols.

**[0066]** The power source module 21 may comprise a rechargeable battery and electronic circuitry that distributes power from the battery to all the other components in the implantable multimodal generator 20.

**[0067]** The signal generator module 23 comprises electronic circuitry that allows the delivery of charge-balanced waveforms of any waveshape, including but not limited to biphasic or monophasic pulses, sinusoidal trains, sawtooth trains, triangle trains, and bursts thereof. In one embodiment, signal generator module 23 comprises electronic circuitry that allows the delivery of noise signals, such as white noise, with a constant power spectral density, or pink noise, with equal energy in octave intervals, or other noise signals in which the energy within the signal spectrum is distributed in other patterns. In one embodiment, a noise signal may be used as the priming mechanism in the techniques disclosed herein. The signal generator module 23 is able to deliver these waveforms at frequencies ranging from 1 Hz to 100 kHz. For pulse delivery, the signal generator module 23 is able to deliver rectangular pulse waves over a range of widths, e.g. as small as 1  $\mu$ s and as large as 250 ms, depending on frequency. The signal generator module 23 is further capable of generating a range of interphase delays. The signal generator module 23 is designed to deliver a signal, with amplitude which is either voltage controlled or current controlled, over a range of values, e.g. 0 V to 30 V or 0 mA to 30 mA, respectively. The signal generator module 23 is also able to generate pulses with a duty cycle. The signal generator module 23 is controlled by the central processing module 25 according to parameters selected by the user in an external programmer unit (or control remote). Signal generator module 23 may be implemented with analog or digital circuitry or a combination thereof. Signal generator module 24 may be structurally and functionally similar or dissimilar to signal generator module 23, and may be independently controlled and programmed.

**[0068]** The breakout and delay module 22 comprises an accurate timer electronic circuitry that can slave one of signal generator modules 23 or 24 to the other, so that a delay can be produced between signals generated therefrom such that a synchronized delivery of such signals can be programmed by a user, for example as shown in Figure 7. The

breakout and delay module 22 also incorporates an electronic circuitry, called breakout, that allows for the user to select an option in which the output array 1 delivers the a particular signal to all top (rostral during spinal cord stimulation) electrode contacts of a pair of electrode arrays (for example, tonic 50 Hz, 250  $\mu$ s pulse width, 3.0 mA), while output array 2 delivers a different signal to all bottom electrode contacts of a pair of electrode arrays (for example, a priming signal of 1,200 Hz, 100  $\mu$ s pulse width, 3.5 mA). An example of this option is shown in Figure 3A. Another option is one illustrated in Figure 3B. The breakout option can be bypassed. In that case, all contacts in a given electrode array will be set at the same modulation parameters as delivered by, for example, signal generator module 23. All contacts in the other electrode array will be set to same modulation parameters as delivered by the other Signal Generator module.

**[0069]** In one embodiment, all or most of the functional blocks of generator 20 may be fabricated on a single integrated circuit chip including a microprocessor and associated memory, wireless transducer and one or more digital oscillators. Alternatively, the digital oscillators may be replaced with wave tables having stored therein mathematical descriptions of various waveform data values which are convertible into analog signals using a digital to analog converter integrated into or associated with the processor module 25 or signal generator modules 23 or 24, depending on their respective implementations. Such wavetables may be stored in processor module 25 or memory module 28. In embodiments the various modules of IMG 20 may communicate over a central bus internal thereto or may have dedicated direct connections therebetween, or any combination thereof.

**[0070]** In one embodiment, IMG 20 or ETS 16 may be programmed by a clinician using software that allows control of all the aspects of the system. The software may be accessible in a computer-based interface called the Clinician Programmer (CP) software. The software may be implemented with wireless communication protocols for remote access of the IMG 20 or ETS 16. ETS 16 may also be provided with a network port such as a USB or micro-USB port for interacting with the CP. In the case of IMG 20, the CP software enables the clinician to communicate with central processing module 25 to define a set of parameters, e.g. any of amplitude, frequency, phase, phase polarity, waveform shape, and width (rectangular waveform), etc., of the signal generated by signal generator modules 23 or 24 and to further define the parameters of their relative timing by defining the operational parameters of breakout and delay module 22. Such defined parameter sets may be stored as one or more configuration programs in memory module 28 or in memory associated with central processing module 25. In one embodiment, one or more configuration programs may be stored in memory associated with remote controller 36 and the parameters thereof transmittable to IMG 20 via telemetry module 26 for control of generator modules 23 or 24 and of breakout and delay module 22. The CP software may enable the clinician to further define which parameter the patient may control with the remote controller 36 and to define any limits on such parameter. For example, the clinician can set and store a configuration program #1 with parameters that provides prime multimodal stimulation consisting of priming with a biphasic symmetric rectangular pulsed signal set at 1,500 Hz, 200  $\mu$ s PW, and current-based amplitude set as a %PPT, and a tonic signal delivering biphasic symmetric rectangular pulses at 50 Hz, 400  $\mu$ s PW, and current-based amplitude set as a %PT. These signals can be delivered to a particular set of electrodes in the leads. The clinician can also set and store a configuration program #2 that provides twin multimodal stimulation consisting of asynchronous biphasic symmetric rectangular pulses at 1,500 Hz, one of them at 200  $\mu$ s PW and the other at 100  $\mu$ s PW and each set at its own current-based amplitude set a particular %PT. These signals can be delivered to a particular set of electrodes in the leads which may be different to that used in configuration program #1. The system allows for setting and storing additional configuration programs deemed necessary for the clinician and according to the storage capacity of the memory module 28. Limited control of the multimodal configuration programs may be available to the patient via a remote controller 36. In one embodiment, the clinician can access one or more configuration programs using the CP to control any of the parameters of a configuration program already stored in the ETS 16 or IMG 20. The patient may be able to browse and/or select any available configuration program with the remote controller 36. The patient may be able to change the current-based amplitude of any particular configuration program up to a particular setting determined by the PPT or PT in order to optimize pain relief, for example. Note the remote controller 36 may be provided with a simple interface, such as a selector switch, or dial to select the appropriate configuration program, or a more sophisticated user interface including a visual display with directional keys or touch sensitive menus.

**[0071]** Figure 4 illustrates conceptually a pair of traces representing signals 40 and 45 used in an example of prime multimodal modulation. Signal 40 functions as a priming waveform and may comprise, for example, biphasic rectangular pulses with a frequency of 1,200 Hz, PW = 200  $\mu$ s and interphase delay of 20  $\mu$ s. Signal 45 functions as the tonic waveform and may comprise, for example, biphasic rectangular pulses with a frequency of 50 Hz, PW = 200  $\mu$ s and interphase delay of 20  $\mu$ s. In this example, the amplitude of the tonic waveform is set to be larger than the amplitude of the priming waveform. Signals 40 and 45 have been offset in Figure 4 for visual clarity. Note in Figures 4-8 the signals representing the tonic and priming waveforms are offset for visual clarity, such offset not meant to limiting in any matter.

**[0072]** Figure 5 illustrates conceptually a pair of traces representing signals 50 and 55 used in an example of prime multimodal modulation. Signal 50 functions as a priming waveform and may comprise, for example, biphasic rectangular pulses with a frequency of 1,200 Hz, PW = 200  $\mu$ s and interphase delay of 20  $\mu$ s. Bottom trace is the tonic waveform and may comprise, for example, biphasic rectangular pulses with a frequency of 50 Hz, PW = 200  $\mu$ s and interphase

delay of 20  $\mu$ s. In this example the amplitude of the tonic waveform is set to be smaller than the amplitude of the priming waveform. Signals 50 and 55 have been offset in Figure 5 for visual clarity.

5 [0073] Figure 6 illustrates conceptually a pair of traces representing signals 60 and 65 used in an example of prime multimodal modulation. Signal 60 functions as a priming waveform and may comprise, for example, biphasic rectangular pulses with a frequency of 1,200 Hz, PW = 200  $\mu$ s and interphase delay of 20  $\mu$ s. Bottom trace is the tonic waveform and may comprise, for example, biphasic rectangular pulses with a frequency of 50 Hz, PW = 200  $\mu$ s and interphase delay of 20  $\mu$ s. In this example the amplitude of the tonic waveform is set to be equal to the amplitude of the priming waveform. Signals 60 and 65 have been offset in Figure 6 for visual clarity.

10 [0074] Figure 7 illustrates conceptually a pair of traces representing signals 70 and 75 used in an example of twin multimodal modulation. Both signals 70 and 75 comprise, for example, biphasic rectangular pulses with a frequency of 1,200 Hz, PW = 200  $\mu$ s and interphase delay of 20  $\mu$ s. In this example, signals 70 and 75 are synchronous to each other and the amplitude of the waveforms is set to be equal. Signal 70 and 75 have been offset in Figure 7 for visual clarity.

15 [0075] Figure 8 illustrates conceptually a pair of traces representing signals 80 and 85 used in an example of twin multimodal modulation. Both signals 80 and 85 may comprise, for example, biphasic square pulses with a frequency of 1,200 Hz, PW = 200  $\mu$ s and interphase delay of 20  $\mu$ s. In this example signals 80 and 85 are asynchronous with each other and the amplitude of one of the signals is set to be larger than the other. Signals 80 and 85 in Figure 8 have been offset for visual clarity.

20 [0076] According to another aspect of the disclosure, the benefits and effects of multimodal modulation, both the prime multimodal technique and the twin multimodal technique, as described herein, may be achieved with a single composite modulation/stimulation signal which has rhythmically varying characteristics, and, therefore, alternating magnetic field characteristics which achieve the same results as two separate signals. In such an embodiment, a composite signal characterized by typically alternating characteristics is utilized to obtain the same stimulation and modulation of the interaction between glial cells and neurons. Techniques for combining the separate signals into a single composite signal may include amplitude modulation, frequency modulation, signal summing, and generation of customized signals with any of periodic or aperiodic characteristics. In addition, pulse width modulated signals having variably changing harmonic energy content may similarly be utilized to achieve the desired multimodal stimulation of glial and neuronal cells. Figures 9-13 illustrate conceptually examples of amplitude modulated, frequency modulated, dual combined sinusoidal, dual combined biphasic rectangular pulse, and frequency changing signals, respectively, that may be utilized for multimodal modulation

25 [0077] In accordance with an embodiment of the present disclosure the central processor module 25 of multimodal generator 20 may access stored numeric data mathematically describing wave shapes for one or more signals and may generate from such data step functions emulating signals at different frequencies. The processor performs algorithmic manipulation of such data to achieve the desired signal processing results. Digital to analog converters associated with the central processing module 25 may convert the processed signal into a single output having the correct amplitude for coupling to one or both electrodes 30 and 32. In this manner, the interactive effects of two separate signals may be achieved with a single electrical signal capable of stimulating/modulating the interaction between glial cells and neurons in a manner which emulates the use of two separate signals. In composite signals emulating a frequency modulated prime multimodal modulation signal, either constituent signal component, e.g. the priming signal or the tonic signal, may function as the program or carrier signals in a frequency modulation algorithm. For example, a frequency modulated multimodal signal can have a carrier frequency larger (e.g. 1,000 Hz) than the modulating frequency (e.g. 50 Hz) resulting in a stimulating signal as illustrated in Figure 10. In another example, a frequency modulated multimodal signal can have a carrier frequency smaller (e.g. 50 Hz) than the modulating frequency (e.g. 1,000 Hz) resulting in a stimulating signal as illustrated in Figure 11. In an example of an amplitude modulated multimodal signal, the carrier frequency can have a carrier priming frequency of, for example, 1,000 Hz, and a modulating frequency of, for example, 50 Hz, resulting in a stimulating signal as illustrated in Figure 9.

30 [0078] Figure 14 illustrates conceptually another embodiment of an implantable system with a human subject in prone position. Shown is an example of an implantable system in which both leads 30 and 32 are positioned above the dorsal spinal cord at a particular vertebral level. A programmable implantable multimodal generator (IMG) 20 is attached to the leads using conductive cables and is powered by a rechargeable or non-rechargeable long-life battery contained within the Power Source module 21, within the implantable multimodal generator 20. An external battery charger 34 may be used for recharging of the generator using inductive, i.e. wireless, charging. A wireless remote control 36, which may be implemented with any number of wireless communication protocols, including Bluetooth or others, may be used to communicate with IMG 20 to enable a patient's adjustment of parameters at the discretion of the physician. The system may be programmed using an external programmer unit, such as a computer (not shown) that can transmit information to the IMG 20 via wireless communication protocols.

35 [0079] Figure 15 illustrates conceptually another embodiment of an implantable system with a human subject in prone position. Shown is an example of an implantable system, similar to that illustrated with reference to Figure 14 herein, in which leads are positioned in the neighborhood of a peripheral nerve.

## Example 1

**[0080]** Referring to Figure 16, an initial pilot study using an animal model for neuropathic chronic pain was carried out (n = 29). In this study, a peripheral nerve injury was surgically induced by transecting the tibial and peroneal branches of the sciatic nerve at the point of trifurcation while sparing the sural nerve (spared nerve injury, SNI, model). After four days of transection, the subject develops mechanical and thermal hypersensitivity (allodynia), which is considered pain-like behavior. Subjects were implanted with a small cylindrical four-contact lead fitted surgically into their epidural space at the vertebral level corresponding to the innervation of the sciatic nerve. At day four post-surgery subjects were behaviorally tested using von Frey filaments. These filaments of different tensile strength are used to measure the sensitivity of a skin area affected by the nerve injury to mechanical stimulation. In the SNI model, the plantar area of the hind paw ipsilateral to injury becomes hypersensitive. A hypersensitive subject will withdraw its paw upon stimulation with a filament of very low tensile strength. Mechanical hypersensitivity was evident in the ipsilateral hind paw in comparison to the contralateral one, which was used as a normal behavior control. In a particular example of prime multimodal stimulation, electrode contacts 3 and 4 were connected to a current source delivering a charge-balanced biphasic symmetric rectangular pulse oscillating at 1,200 Hz and a PW of 30  $\mu$ s at an amplitude of 0.1 mA (33% motor threshold, MT). This priming signal was set on for 10 minutes before a tonic signal was sent simultaneously at electrode contacts 1 and 2. This tonic signal was a charged balanced biphasic symmetric rectangular pulse oscillating at 50 Hz, PW of 50  $\mu$ s and amplitude of 0.2 mA (66% MT). In a particular example of twin multimodal stimulation, electrode contacts 3 and 4 were connected to a current source delivering a charge-balanced biphasic rectangular pulse oscillating at 1,200 Hz and a PW of 30  $\mu$ s at an amplitude of 0.1 mA (33% motor threshold, MT). This signal was set on for 10 minutes before another charged balanced biphasic rectangular pulse oscillating at same frequency and PW but different amplitude of 0.2 mA (66% MT) was sent simultaneously at electrode contacts 1 and 2. In either case, electrical stimulation was on continuously for two hours and behavioral testing for mechanical sensitivity was performed every fifteen minutes while the subject was being stimulated. Behavioral testing was continued every fifteen minutes after stimulation was turned off for one hour and then every hour until three hours post stimulation. Figure 16 shows the results as an average of the various recordings obtained from nine subjects.

**[0081]** Behavioral data indicates that multimodal stimulation improves mechanical allodynia after fifteen minutes of stimulation with the improvement lasting for more than one hour after the stimulation is turned off, indicating that there is a residual effect of the applied fields which suggest modulation of the nervous system.

## Example 2

**[0082]** In the example, the effect of spinal cord stimulation on gene expression in the ipsilateral dorsal spinal cord (DC) upon induction of chronic neuropathic pain after peripheral nerve injury was investigated. Specifically, in the example we compared the full genome of one the most commonly used rodent model for chronic neuropathic pain (spare nerve injury, SNI) upon continuous SCS relative to sham animals, i.e. animals in which pain model was induced, were implanted, but not stimulated.

**[0083]** The full genome microarray kit available for the laboratory rat used comprised about 21,000 genes. Enrichment analysis based on clustering statistics (using WGCNA) allowed for the identification of modules (or subsets) that contain genes that are highly correlated to each other in terms of biological role. Gene ontology analysis allowed for the grouping of genes within a module in terms of more specific biological processes and molecular functionality. Further refinement allows for the identification of key genes within a particular pathway.

**[0084]** It was found by comparison of the genome of the treated animals that SCS upregulates and down-regulates genes implied in various interrelated processes, as described herein.

## Comparative Genomics at the Spinal Cord

**[0085]** Considering that stimulation occurs atop the dorsal region of the spinal cord, we concentrated effort on elucidating the role of genes on molecular functionality and biological functions associated to this tissue. WGCNA identified that SCS significantly upregulated genes involved in activation of the immune system (false discovery rate (FDR) adjusted P-value = 0.016); while down-regulating genes that are involved in phosphorylation and activities related to transmembrane transport (FDR P-value = 0.011) as well as regulation of neuronal activity including regeneration and development. Refinement of the data identified 52 key genes. Out of these, the following are noteworthy, since they are involved in the process of glial activation, immune response and neuronal activity:

Calcium binding protein (cabp1): This gene is down-regulated by SCS. The protein associated to this gene regulates calcium-dependent activity of inositol 1,4,5-triphosphate (ITP) receptors. This receptor is involved in the signaling between astrocytes via calcium waves, which play a key role in the intercellular communication that propagates astrocyte activation. Down regulation of this gene should diminish the activation of astrocytes that is conducive to synaptic reshaping that

develops into a chronic pain state.

**[0086]** Toll-like receptor 2 (tlr2): This gene is up regulated by SCS. Toll-like receptor2 is expressed by activated glial cells. This gene is expressed in microglia and astrocytes, but expression in activated microglia is larger than expression in astrocytes. The protein associated to the gene induces a cascade of events that may lead to the secretion of anti-inflammatory cytokines, such as IL-10.

**[0087]** **Chemokine cxcl16:** This gene is up regulated by SCS. This is a transmembrane chemokine which drives the interplay between glial cells and neurons as a result of stimulus. Cxcl16 is expressed by microglia and astrocytes as a neuroprotective agent. Up-regulation of this gene by SCS is indicative of a neuroprotective process in the spinal cord likely involving the modulation of microglia.

**[0088]** **Glial maturation factor (Gmfg):** This gene is up regulated by SCS. This gene has been thought to be involved in glial differentiation and neural regeneration. There is not much known about this gene. Its up regulation by SCS may be associated to glial activation processes that may lead to neuronal regeneration.

Other key genes up-regulated or down-regulated by spinal cord stimulation are described with reference to Table 1-1 below:

Table 1-1

Selected Genes up-regulated by SCS			
Process	Gene	Description	Notes
	Ly86	lymphocyte antigen 86	Cooperate with toll like receptor to mediate the innate immune response
	Cd68	Cd68 molecule	Phagocytic activities of tissue macrophages
	Apbb1ip	amyloid beta (A4) precursor protein	Signal transduction from Ras activation to actin cytoskeletal remodeling
	Casp1	caspase 1	Cleaves IL-1 beta
	Ifi30	interferon gamma inducible	MHC class II-restricted antigen processing
	Cd53	Cd53 molecule	Mediate regulation of cell development, activation, growth and motility
	Tnfaip8l2	tumor necrosis factor, alpha-induced protein	Regulator of innate and adaptive immunity by maintaining immune homeostasis
	Il1b	interleukin 1 beta	Mediator of the inflammatory response. Induces cyclooxygenase-2 (COX2) to contribute to inflammatory pain.
	Cxcl17	chemokine (C-X-C motif) ligand 17	May be a chemokine regulating recruitment of monocytes and immature dendritic cells
	Itgb2	integrin, beta 2	Participate in cell adhesion as well as cell-surface mediated signaling
	Timp1	TIMP metalloproteinase inhibitor 1	Inhibitors of the matrix metalloproteinases, involved in degradation of the extracellular matrix
	Tnfsf12	Tumor Necrosis Factor (Ligand) Superfamily,	Cytokine that belongs to the tumor necrosis factor (TNF) ligand family. It can induce apoptosis via multiple pathways of cell death in a cell type-specific manner.
	Il2rg	Interleukin 2 Receptor, Gamma	Common subunit for the receptors for a variety of interleukins

(continued)

Selected genes down-regulated by SCS				
5	Ion channel regulation	Wwp1	WW domain containing E3 ubiquitin protein ligase 1	Ubiquitinates and promotes degradation of SMAD2 in response to TGF-beta signaling
10		Micu3	Mitochondrial calcium uptake family	Essential regulator of mitochondrial calcium uptake under basal conditions
15		Grin2a	Glutamate receptor, ionotropic, N-methyl D-aspartate 2A	Receptor activation requires binding of glutamate and glycine, leads to an influx of calcium into postsynaptic region activating pathways. NMDA receptors have a critical role in excitatory synaptic transmission and plasticity in the CNS.
20	Binding and metabolic pathways	Amph	Amphiphysin	Associated with the cytoplasmic surface of synaptic vesicles
25		Gabrg1	Gamma-Aminobutyric Acid (GABA) A receptor, Gamma 1	Protein encoded by this gene is an integral membrane protein and inhibits neurotransmission by binding to the benzodiazepine receptor and opening an integral chloride channel
30		Gabra2	Gamma-Aminobutyric Acid (GABA) A Receptor, Alpha 2	
35	Cell growth	Gria3	Glutamate receptor, ionotropic, AMPA 3	Receptor for glutamate, functions as ligand-gated ion channel in the CNS, plays an important role in excitatory synaptic transmission
40		Kcna1	Potassium Voltage-Gated Channel, Shaker-Related Subfamily	Mediates the voltage-dependent potassium ion permeability of excitable membranes
		Kifc3	Kinesin Family Member C3	Molecular motor that use ATP hydrolysis to translocate cargoes along microtubules
	ATP related, transmembrane/ transporter activity	Igsf1	Immunoglobulin Superfamily	Thought to participate in the regulation of interactions between cells
	Cell regulation	Oprm1	Opioid Receptor, Mu 1	Principal target of endogenous opioid peptides and opioid analgesic agents such as beta-endorphin and enkephalins.

**[0089]** Many of the genes involved in the inflammatory and immune response are associated to glial activity. Peripheral nerve injury is accompanied by regulation of genes and proteins not only in the site of injury, but also in the afferent ipsilateral CNS structures such as the DRG and the spinal cord. We recently obtained the proteomics in the spinal cord and DRG of the SNI animal model for neuropathic pain. This study indicates that there are transport and translocation of proteins along the axon towards the soma, and then reciprocal protein transport back to the periphery to induce axon regeneration. Interestingly, the spinal cord presents with neuroprotective proteins, some associated to glial cell activation. The activation of glial cells following injury induces a cascade of events including an inflammatory and immune response, which then develops into peripheral sensitization that is conducive to ectopic firing of neurons. The alarm eventually extends to the CNS at the level of the spinal cord, where the microglia would try to protect the integrity of the system. Eventually, glial cells overreact and induce the release of factors that reshape the synapses. These changes in the synaptic plasticity manifest as chronic pain.

**[0090]** The results indicate that electrical stimulation of the spinal cord elicits the regulation of genes and proteins that modulate the interactions between glial cells and neurons. It is plausible that these molecular events produce analgesia.

### Example 3

**[0091]** The effect of phase polarity on the modulation of genes previously presented was carried out using an animal



model of chronic neuropathic pain. In this example, tissues from the spinal cord were obtained from animals which have been stimulated using a rectangular waveform at a frequency of 50 Hz and a pulse width of 200  $\mu$ s per phase which were either monophasic cathodic, monophasic anodic, or symmetric biphasic with an initial cathodic polarity. RNA from tissues was extracted and transcribed into DNA using standard PCR techniques. The amount of DNA was then quantified and standardized. Based on our previous experiments (example 2) a panel of genes including markers for glial activation (tlr2, cxcl16), calcium-dependent glial processes (cabp1), immune system activation (cd68), and an opioid receptor (oprm1) were selected for analysis.

**[0092]** Figures 32(a)-(e) illustrate conceptually graphs of expression of selected genes relative to the polarity of the phase used in the stimulation waveform, including a) Calcium binding protein (cabp1); b) Chemokine cxcl16; c) Toll-like receptor 2 (tlr2); d) Cd68 molecule; and e) Opioid receptor mu-1 (oprm1). It is evident that the polarity of the signal phase influences the regulation of genes. Biphasic stimulation increases the amount of genes related to glial activation (tlr2 and cxcl16) relative to anodic and cathodic stimulation in response to the release of glutamate from astrocytes. Biphasic stimulation increases the amount of cabp1 relative to monophasic stimulation (cathodic or anodic). Monophasic stimulation (cathodic or anodic) and biphasic stimulation produces similar amounts of the immune-related gene cd 68 and expression of the gene coding for the opioid receptor, oprm1.

#### Example 4

**[0093]** The subject patient was a 55 y/o female patient with diagnosis of Failed Back Surgery Syndrome complaining of severe axial low back pain radiating to bilateral lower extremities all the way to the feet for over eight years. Patient failed multiple medical treatments including physical therapy, medication management and surgical intervention.

**[0094]** The patient underwent a spinal cord stimulator trial with a conventional SCS system. Two leads were positioned in the posterior epidural space with the tip of the leads located at the junction of T7 and T8. Patient returned two days later for reprogramming as leads migrated down as confirmed by x-ray fluoroscopy. After lead repositioning, patient reported paresthesia coverage from torso level down to leg while in prone position. Reprogramming took place while subject was seating/standing; however patient reported no coverage on back. Treatment seemed to only cover from waist down to legs. Multiple attempts failed to improve the outcome. At the conclusion of the trial with conventional SCS, the patient reported only 25% relief.

**[0095]** At this point, the multimodal stimulation system was applied with prime modality as described herein. The system was reprogrammed using two external generators. One was set at 70 Hz, 700  $\mu$ s PW in the upper contacts of the parallel leads. The other was set for priming at 1,000 Hz, 200  $\mu$ s PW. The patient reported block of paresthesia when the 1,000 Hz was on, while the amplitude of the 70 Hz was 3 mA. Amplitude was increased slowly until 3.6-3.7 mA when she experienced paresthesia. Amplitude of the 1,000 Hz signal was set at 2 mA when patient went home. Patient reported no pain in the back.

**[0096]** Patient returned two days later for reprogramming of the multimodal stimulation. After reprogramming, patient continued experiencing pain relief without tingling. Particularly important is pain relief in the back. Pain relief was also experienced in the legs, but not in the feet. Paresthesia was also perceived at 3.7 mA when the 1,000 Hz stimulation was on, and 3.0 mA when was off. Amplitude of the 1,000 Hz signal was set below 2 mA, which is below the PPT. Patient went home with 2 mA at 1,000 Hz and 2.9 mA at 70 Hz. Patient was able to walk well, flex downward and reported immediate pain relief in the back.

**[0097]** Patient returned four days later. Subject had adjusted the amplitude of the 1,000 Hz down to 1.7 mA because she felt muscle fatigue in the back. The amplitude of the 70 Hz was set at 2.3 mA.

**[0098]** In summary of trial:

1. Subject patient did not experienced paresthesias during the four days of treatment.
2. Patient reported that the Multimodal Prime treatment was superior to Tonic treatment.
3. Patient reported no back pain.
4. Sharp/stabbing pain in leg was significantly reduced.
5. Burning sensation in the feet was not alleviated which prevented patient from long walks.
6. Significant reduction in opioid consumption.
7. She reported about overall 70% pain relief with multimodal stimulation.

#### Example 5

**[0099]** The subject patient was a 70 y/o male diagnosed with radiculopathy. Patient has suffered from condition since for about 17 years. Subject has been treated with conventional treatments without clinical success. Pain numerical rate score before treatment was reported as 10, with pain in the back radiating to the legs. A pair of SCS trial leads were implanted using a non-parallel alignment (i.e. they were offset from each other), and a tonic program has been set.

## EP 3 291 878 B1

Patient reported 70-75% pain relief in the back and 80% pain relief in the leg from the conventional treatment. Patient reported improvement in sleep and a decrease of Vicodin ingestion. Subject reported liking the paresthesia sensation relative to experiencing pain. Patient reported that discomfort in left foot was not being eliminated by treatment.

5 [0100] Patient was then reprogrammed using multimodal stimulation with a prime arrangement with a priming parameters set at 1,200 Hz, 150  $\mu$ s PW and 5.5 mA, while low frequency parameters were set at 50 Hz, 400  $\mu$ s PW and 3.2 mA. Patient experienced paresthesia at 3.5 mA.

[0101] Patient did not experience pain in back and legs during the following couple of days and was able to adjust low frequency up and down as he felt comfortable with the paresthesias. However, he maintained the amplitude below the paresthesia threshold for most of the time.

10 [0102] In the evening the next day, patient was very active climbing up and down stairs (an activity he avoided before SCS treatment). Family was impressed he could walk as much as he did that day. On the following day he was active around the house doing some activities in his yard, particularly handling the garbage. He admitted he overdid activities in the last couple of days and thus reported pain at night. He ingested 1 Vicodin and increased level of low frequency signal to paresthesia sensation and turned it down to go to sleep. He slept well for 7 hours-. Previous nights he had slept very well for about 8-9 hours. On the afternoon of the following day, he reported no pain (score of 0) in both back and leg and no discomfort or pain in the feet.

15 [0103] Patient likes the fact he can feel paresthesias for reassuring his pain relief, but enjoys being able to have pain relief without having the constant tingling. Patient was disappointed he was not going to have the multimodal treatment option when permanently implanted.

20 [0104] In summary:

1. Patient did not experience paresthesias most of the time during three days. He adjusted amplitude of low frequency tonic stimulator to feel paresthesia when pain recurred and adjusted amplitude down to paresthesia-free to maintain pain relief.

25 2. Patient was able to reduce pain medication ingestion.

3. Patient reported no back pain and no pain in leg and feet. He reported 100% relief with prime, except when he increased his daily activity considerably relative to usual one he had before stimulation.

4. Patient reported significant improvement on sleep habits.

30 5. Patient indicated he likes the ability of set paresthesia as a way of reaffirming a stimulation dosage that will guarantee pain relief when amplitude is then turned down below paresthesia while maintaining pain relief.

### Example 6

35 [0105] Referring to Figures 17A-B, an observational study using human volunteers was carried out (n = 10). These subjects were part of a trial period for commercial spinal cord stimulation systems administered under standard clinical practice. Subjects voluntarily accepted to try multimodal modulation after they had completed their trial period. Success in a trial period is indicated by pain relief equal or above 50% relative to the pain numerical rating score (NRS) present before the spinal cord stimulation therapy was commenced. All subjects had been implanted with two eight-electrode trial leads. Six of them had leads staggered relative to each other and four of them had leads parallel to each other. Five of the subjects had trialed conventional tonic stimulation systems (50-70 Hz) and five of them had trialed a high frequency system (10,000 Hz). Two of the subjects failed the trial with conventional tonic stimulation (50-70 Hz). Nine of the subjects tried multimodal stimulation using the prime modality and one of them tried the twin modality. Multimodal stimulation was tried for as short as 3 hours and for as long as 4 days. All the ten subjects successfully tried multimodal stimulation under the paresthesia or perception threshold (PT). The mean pain relief of the subjects was 71% and all subjects declared to be satisfied with multimodal stimulation therapy.

45 [0106] The reader will appreciate that the multimodal modulation techniques described herein, including the Prime and Twin modulation techniques, as well as modulation achieved with a composite signal, e.g. frequency, amplitude, or pulse width modulated, and multi-modal modulation, can be utilized for regulation of genes and proteins that modulate the interactions between glial cells and neurons as described herein.

50 [0107] As used herein, the term "pharmacological substance" means any tangible chemical, drug, medicine or therapeutic substance, either synthetic or naturally occurring, regardless of the form of administration to the subject, that is administered to the body of the subject.

[0108] At various places in the present specification, values are disclosed in groups or in ranges. It is specifically intended that the description include each and every individual subcombination of the members of such groups and ranges and any combination of the various endpoints of such groups or ranges. For example, an integer in the range of 0 to 40 is specifically intended to individually disclose 0, 1, 2, 3, 4, 5, 6, 7, 8, 9, 10, 11, 12, 13, 14, 15, 16, 17, 18, 19, 20, 21, 22, 23, 24, 25, 26, 27, 28, 29, 30, 31, 32, 33, 34, 35, 36, 37, 38, 39, and 40, and an integer in the range of 1 to 20 is specifically intended to individually disclose 1, 2, 3, 4, 5, 6, 7, 8, 9, 10, 11, 12, 13, 14, 15, 16, 17, 18, 19, and 20.

**[0109]** For purposes of clarity and a concise description, features are described herein as part of the same or separate embodiments, however, it will be appreciated that the concepts may include embodiments having combinations of all or some of the features described herein.

**[0110]** It will be obvious to those recently skilled in the art that modifications to the apparatus and process disclosed here in may occur, including substitution of various component values or nodes of connection. For example, although the embodiments described herein disclose primarily the use of pulsed rectangular signals, other waveform shapes may be similarly used to obtain the same effects. For example, any of a monophasic pulse wave, charge balanced biphasic pulse wave, charge imbalanced biphasic pulse wave, charge balanced biphasic with delay pulse wave, charge balanced biphasic fast reversal wave, and charge balanced biphasic slow reversal wave may be utilized as stimulating waveforms in the multimodal modulation techniques described herein. In addition, other varying electromagnetic fields defined by periodic electric signals having different waveform shapes may be used as well as noise signals and even non-periodic electric signals having irregular nonrepeating shapes.

**Claims**

1. A system comprising:

a signal generation module (17, 19, 23, 24) comprising at least a first and a second electric signal source or terminal,  
and

one or more leads (30, 32) having one or more electrodes (1-16) configured for exposing glial cells and neurons of a subject simultaneously to a first electromagnetic stimulus and a second electromagnetic stimulus, said stimuli being provided by first and second electromagnetic fields, respectively, wherein the signal generation module is configured for having an operating mode for providing a first electric signal to a first subgroup of the electrodes and a second electric signal to a second subgroup of the electrodes, the first and second electric signals having at least one uncommon parameter therebetween, the first and second electric signals generating said first and second electromagnetic fields, respectively,

wherein the first subgroup of the electrodes is electrically coupled to the first electric signal source or terminal and the second subgroup of the electrodes is electrically coupled to the second electric signal source or terminal.

2. The system of claim 1, wherein the system is configured for managing pain in a subject, the system being configured to:

A) provide a first varying electromagnetic field for a first duration of time configured to lower a threshold for depolarization of nerve fibers in the subject; and

B) provide a second varying electromagnetic field during a second duration of time not identical to the first duration of time configured to simultaneously modulate glial cell activity.

the system being configured to manipulate of any of the frequency, amplitude, waveform shape, width and phase of electrical signal generating the first and second varying electromagnetic fields, respectively, to modulate the behavior of glial cells and interaction thereof with neurons at the synaptic level.

3. The system of claim 2, wherein the first varying electromagnetic field is an oscillating electromagnetic field and the second varying electromagnetic field is an oscillating electromagnetic field.

4. The system of any of the claims 2 or 3, wherein the first varying electromagnetic field is provided by the first electric signal having a current amplitude set to a value corresponding to a percentage of a Priming Perception Threshold (PPT) of the subject, and

wherein the second varying electromagnetic field is provided by the second electric signal having a current amplitude set to a value corresponding to a percentage of the paresthesia threshold (PT).

5. The system of any of the preceding claims, wherein the signal generation module is configured for having an operating mode for providing a Priming signal to the first subgroup of electrodes and simultaneously providing a Tonic signal to the second subgroup of electrodes.

6. The system of any of the preceding claims, wherein the system further comprises an output unit, wherein the output unit comprises a first output for connection to the first electrode and a second output for connection to the second electrode.

7. The system of any of the preceding claims, wherein the first electric signal and the second electric signal have any of different respective amplitudes, frequencies, relative phases, phase polarities, waveform shapes, and widths.
8. The system of any one of the preceding claims, wherein the second electric signal is a tonic stimulation signal and the first electric signal has a frequency higher than a frequency of the tonic stimulation signal.
9. The system of any of the preceding claims, wherein the signal generation module is configured to generate a composite electric signal comprising any of a frequency modulated signal, an amplitude modulated signal or a pulse modulated signal.
10. The system of claim 9, further comprising an enclosure of biocompatible material surrounding the signal generation module and output unit.
11. The system of any of claims 9 or 10, wherein both the first and second electrical signals have different respective frequencies below 1,500 Hz.
12. The system of any of claims 9-11, wherein the first and second electrical signals comprise one of monophasic electrical signals and biphasic electrical signals.

## Patentansprüche

### 1. System, umfassend:

ein Signalerzeugungsmodul (17, 19, 23, 24), umfassend mindestens eine erste und eine zweite elektrische Signalquelle oder einen ersten und einen zweiten Anschluss, und  
eine oder mehrere Leads (30, 32), die eine oder mehrere Elektroden (1-16) aufweisen, die zum Freilegen von Gliazellen und Neuronen eines Subjekts gleichzeitig an einen ersten elektromagnetischen Reiz und einen zweiten elektromagnetischen Reiz konfiguriert sind, wobei die Reize jeweils durch ein erstes und ein zweites elektromagnetisches Feld bereitgestellt werden, wobei das Signalerzeugungsmodul konfiguriert ist, um einen Betriebsmodus zum Bereitstellen eines ersten elektrischen Signals an eine erste Untergruppe der Elektroden und eines zweiten elektrischen Signals an eine zweite Untergruppe der Elektroden aufzuweisen, wobei das erste und das zweite elektrische Signal mindestens einen ungewöhnlichen Parameter dazwischen aufweisen, wobei das erste und das zweite elektrische Signal jeweils das erste und das zweite elektromagnetische Feld erzeugen, wobei die erste Untergruppe der Elektroden mit der ersten elektrischen Signalquelle oder dem ersten Anschluss elektrisch gekoppelt ist und die zweite Untergruppe der Elektroden mit der zweiten elektrischen Signalquelle oder dem zweiten Anschluss elektrisch gekoppelt ist.

### 2. System nach Anspruch 1, wobei das System zum Behandeln von Schmerz bei einem Subjekt konfiguriert ist, wobei das System konfiguriert ist zum:

- A) Bereitstellen eines ersten variierenden elektromagnetischen Felds für eine erste Zeitdauer, die konfiguriert ist, um eine Schwelle für eine Depolarisation von Nervenfasern in dem Subjekt zu senken; und  
B) Bereitstellen eines zweiten variierenden elektromagnetischen Felds während einer zweiten Zeitdauer, die mit der ersten Zeitdauer nicht identisch ist, die konfiguriert ist, um eine Gliazellenaktivität gleichzeitig zu modulieren.

wobei das System konfiguriert ist, um eine beliebige der Frequenz, der Amplitude, des Wellenformverlaufs, der Breite und der Phase des elektrischen Signals, das das erste und das zweite variierende elektromagnetische Feld erzeugt, jeweils zu manipulieren, um das Verhalten von Gliazellen und deren Interaktion mit Neuronen auf der synaptischen Ebene zu modulieren.

### 3. System nach Anspruch 2, wobei das erste variierende elektromagnetische Feld ein oszillierendes elektromagnetisches Feld ist und das zweite variierende elektromagnetische Feld ein oszillierendes elektromagnetisches Feld ist.

### 4. System nach einem der Ansprüche 2 oder 3, wobei das erste variierende elektromagnetische Feld durch das erste

elektrische Signal, das eine Stromamplitude aufweist, die auf einen Wert eingestellt ist, der einem Prozentsatz einer Vorbereitungswahrnehmungsschwelle (PPT) des Subjekts entspricht, bereitgestellt wird, und wobei das zweite variierende elektromagnetische Feld durch das zweite elektrische Signal, das eine Stromamplitude aufweist, die auf einen Wert eingestellt ist, der einem Prozentsatz der Parästhesieschwelle (PT) entspricht, bereitgestellt wird.

- 5 5. System nach einem der vorstehenden Ansprüche, wobei das Signalerzeugungsmodul konfiguriert ist, um einen Betriebsmodus zum Bereitstellen eines Priming-Signals an die erste Untergruppe von Elektroden und zum gleichzeitigen Bereitstellen eines Tonic-Signals an die zweite Elektrodenuntergruppe aufzuweisen.
- 10 6. System nach einem der vorstehenden Ansprüche, wobei das System ferner eine Ausgabeeinheit umfasst, wobei die Ausgabeeinheit einen ersten Ausgang für eine Verbindung mit der ersten Elektrode und einen zweiten Ausgang für die Verbindung mit der zweiten Elektrode umfasst.
- 15 7. System nach einem der vorstehenden Ansprüche, wobei das erste elektrische Signal und das zweite elektrische Signal beliebige von unterschiedlichen jeweiligen Amplituden, Frequenzen, relativen Phasen, Phasenpolaritäten, Wellenformenverläufen und Breiten aufweisen.
- 20 8. System nach einem der vorstehenden Ansprüche, wobei das zweite elektrische Signal ein tonisches Stimulations-signal ist und das erste elektrische Signal eine Frequenz aufweist, die höher als die Frequenz des tonischen Stimulations-signals ist.
- 25 9. System nach einem der vorstehenden Ansprüche, wobei das Signalerzeugungsmodul konfiguriert ist, um ein zusammengesetztes elektrisches Signal zu erzeugen, umfassend ein beliebiges eines frequenzmodulierten Signals, eines amplitudenmodulierten Signals oder eines pulsmodulierten Signals.
- 30 10. System nach Anspruch 9, ferner umfassend eine Ummantelung aus biokompatiblen Material, die das Signalerzeugungsmodul und die Ausgabeeinheit umgibt.
- 35 11. System nach einem der Ansprüche 9 oder 10, wobei sowohl das erste als auch das zweite elektrische Signal unterschiedliche jeweilige Frequenzen unter 1.500 Hz aufweisen.
12. System nach einem der Ansprüche 9 bis 11, wobei das erste und das zweite elektrische Signal eines von einphasigen elektrischen Signalen und zweiphasigen elektrischen Signalen umfassen.

## Revendications

### 1. Système comprenant :

40 un module de génération de signaux (17, 19, 23, 24) comprenant au moins une première et une seconde source ou borne de signaux électriques,  
et  
45 un ou plusieurs fils (30, 32) ayant une ou plusieurs électrodes (1-16) configurées pour exposer les cellules gliales et les neurones d'un sujet simultanément à un premier stimulus électromagnétique et à un second stimulus électromagnétique, lesdits stimuli étant fournis par un premier et un second champs électromagnétiques, respectivement, dans lequel le module de génération de signaux est configuré pour avoir un mode de fonctionnement permettant de fournir un premier signal électrique à un premier sous-groupe d'électrodes et un second signal électrique à un second sous-groupe d'électrodes, les premier et second signaux électriques ayant au moins un paramètre non commun entre eux, les premier et second signaux électriques générant lesdits premier et second champs électromagnétiques, respectivement,  
50 dans lequel le premier sous-groupe d'électrodes est couplé électriquement à la première source ou borne de signal électrique et le second sous-groupe d'électrodes est couplé électriquement à la seconde source ou borne de signal électrique.

### 2. Système selon la revendication 1, dans lequel le système est configuré pour gérer la douleur chez un sujet, le système étant configuré pour :

## EP 3 291 878 B1

- A) fournir un premier champ électromagnétique variable pendant une première durée configuré pour abaisser le seuil de dépolarisation des fibres nerveuses chez le sujet ; et  
B) fournir un second champ électromagnétique variable pendant une seconde durée non identique à la première durée, configuré pour moduler simultanément l'activité des cellules gliales.

5

le système étant configuré pour manipuler l'une quelconque de la fréquence, l'amplitude, la forme d'onde, la largeur et la phase du signal électrique générant le premier et le second champs électromagnétiques variables, respectivement, afin de moduler le comportement des cellules gliales et leur interaction avec les neurones au niveau synaptique.

10

**3.** Système selon la revendication 2, dans lequel le premier champ électromagnétique variable est un champ électromagnétique oscillant et le second champ électromagnétique variable est un champ électromagnétique oscillant.

15

**4.** Système selon l'une quelconque des revendications 2 ou 3, dans lequel le premier champ électromagnétique variable est fourni par le premier signal électrique ayant une amplitude de courant fixée à une valeur correspondant à un pourcentage d'un seuil de perception d'amorçage (PPT) du sujet, et dans lequel le second champ électromagnétique variable est fourni par le second signal électrique dont l'amplitude du courant est fixée à une valeur correspondant à un pourcentage du seuil de paresthésie (PT).

20

**5.** Système selon l'une quelconque des revendications précédentes, dans lequel le module de génération de signaux est configuré pour avoir un mode de fonctionnement permettant de fournir un signal d'amorçage au premier sous-groupe d'électrodes et de fournir simultanément un signal de tonicité au second sous-groupe d'électrodes.

25

**6.** Système selon l'une quelconque des revendications précédentes, dans lequel le système comprend en outre une unité de sortie, dans lequel l'unité de sortie comprend une première sortie pour la connexion à la première électrode et une seconde sortie pour la connexion à la seconde électrode.

30

**7.** Système selon l'une quelconque des revendications précédentes, dans lequel le premier signal électrique et le second signal électrique ont des amplitudes, des fréquences, des phases relatives, des polarités de phase, des formes d'onde et des largeurs respectives différentes.

35

**8.** Système selon l'une quelconque des revendications précédentes, dans lequel le second signal électrique est un signal de stimulation tonique et le premier signal électrique a une fréquence supérieure à une fréquence du signal de stimulation tonique.

40

**9.** Système selon l'une quelconque des revendications précédentes, dans lequel le module de génération de signaux est configuré pour générer un signal électrique composite comprenant un signal modulé en fréquence, un signal modulé en amplitude ou un signal modulé en impulsions.

45

**10.** Système selon la revendication 9, comprenant en outre une enceinte en matériau biocompatible entourant le module de génération de signaux et l'unité de sortie.

**11.** Système selon l'une quelconque des revendications 9 ou 10, dans lequel les premier et second signaux électriques ont des fréquences respectives différentes inférieures à 1 500 Hz.

50

**12.** Système selon l'une quelconque des revendications 9 à 11, dans lequel les premier et second signaux électriques comprennent des signaux électriques monophasiques et des signaux électriques biphasiques.

55

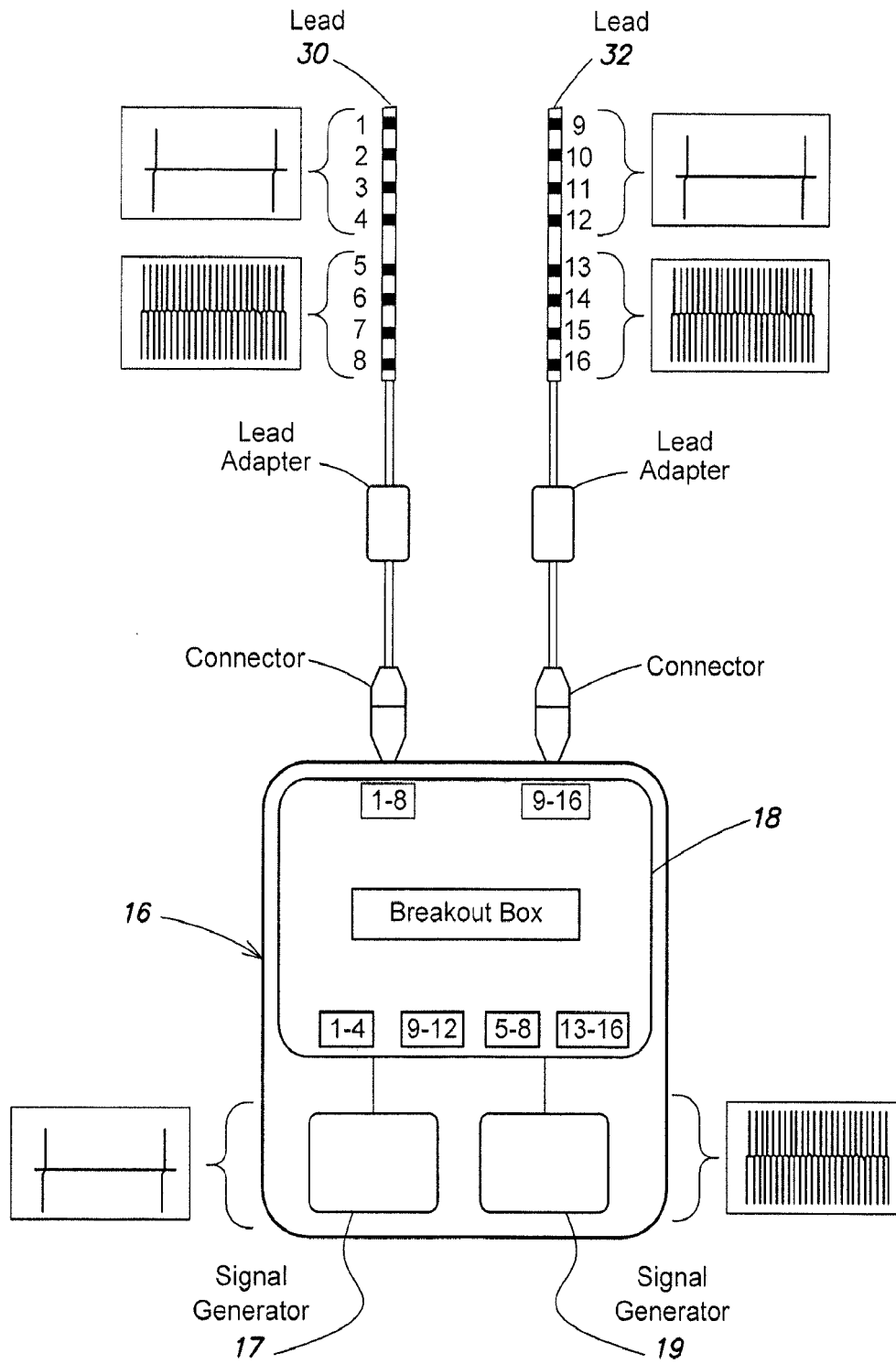

FIG. 1

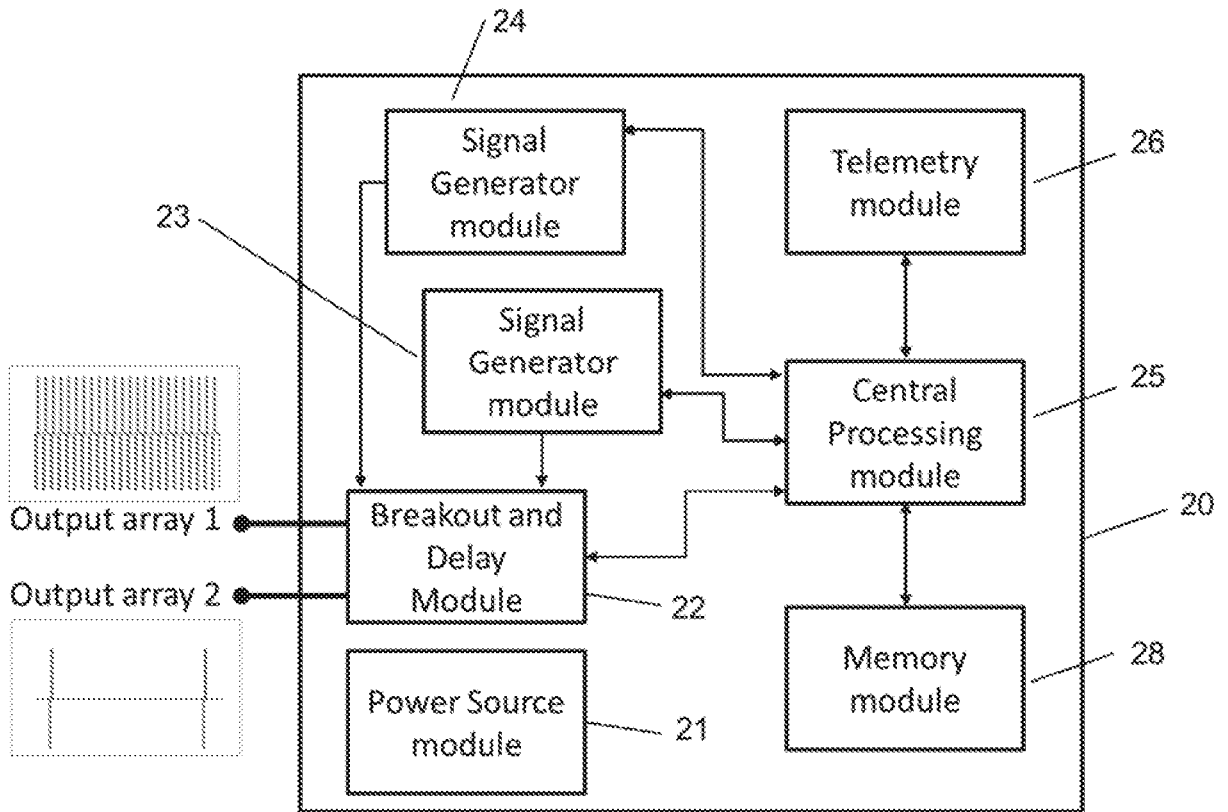
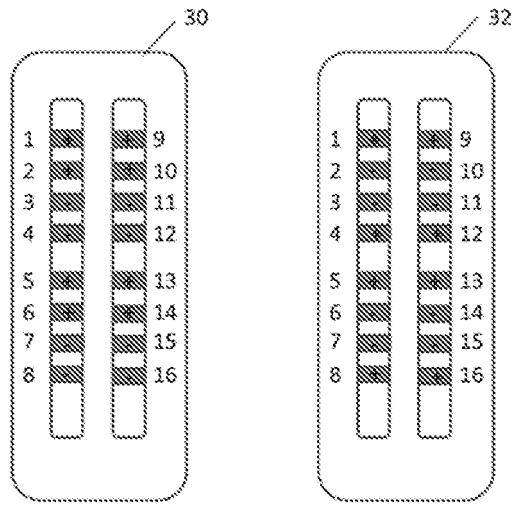

Figure 2





5-8 and 13-16 = priming signal

1-4 and 9-12 = second signal

Figure 3A

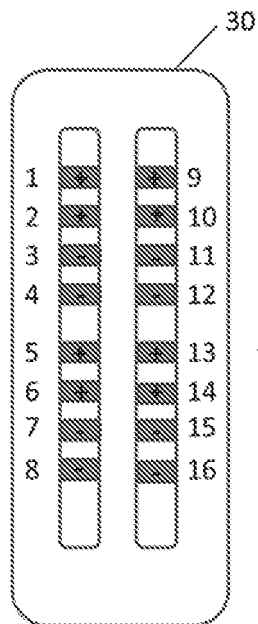

1, 2, 9, 10 and 7, 8, 15, 16 = priming signal

3, 4, 11, 12 and 5, 6, 13, 14 = second signal

Figure 3B

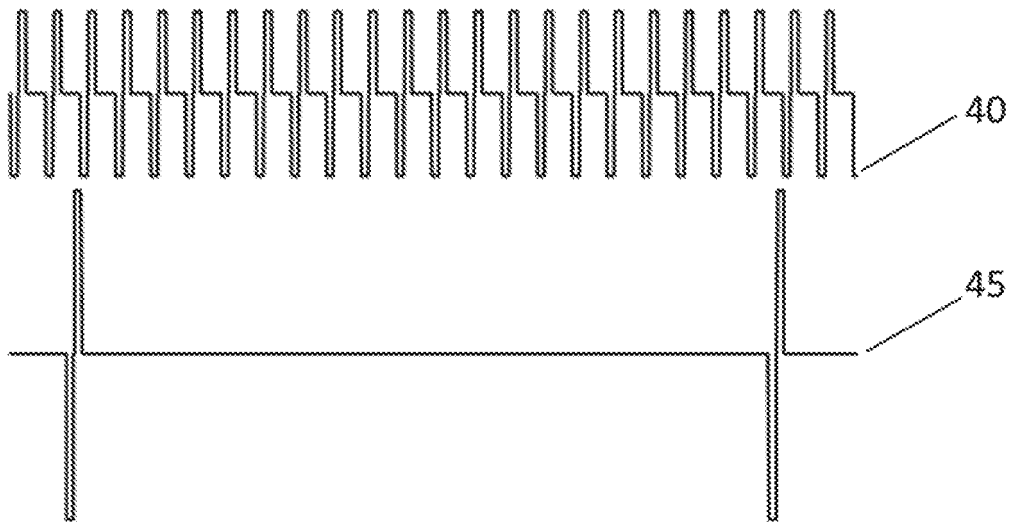

Figure 4

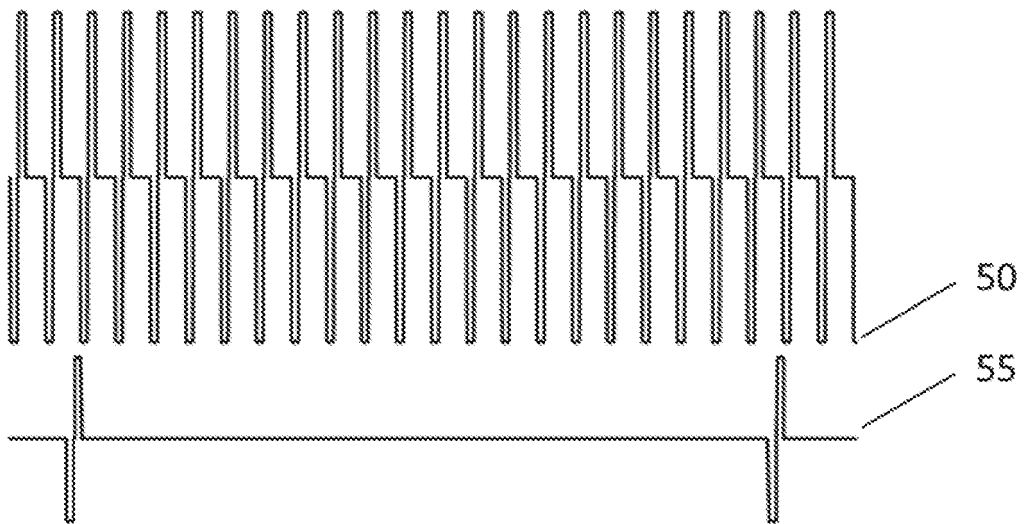

Figure 5

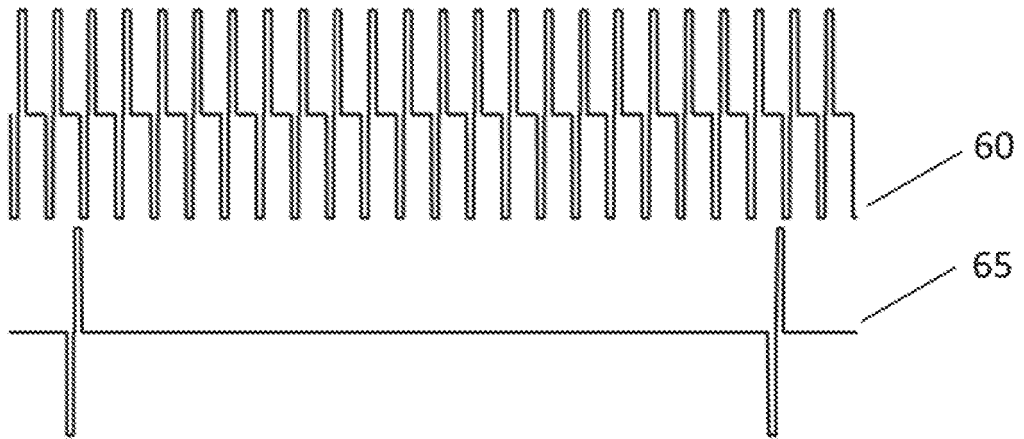

Figure 6

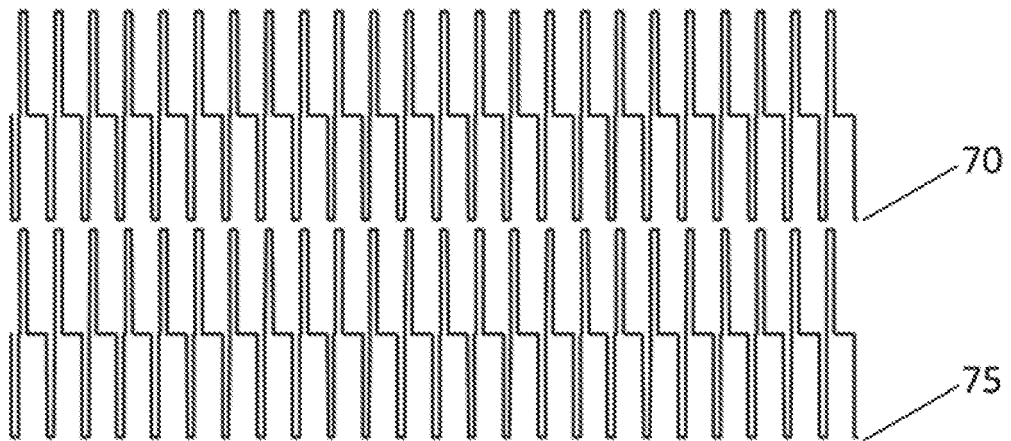

Figure 7

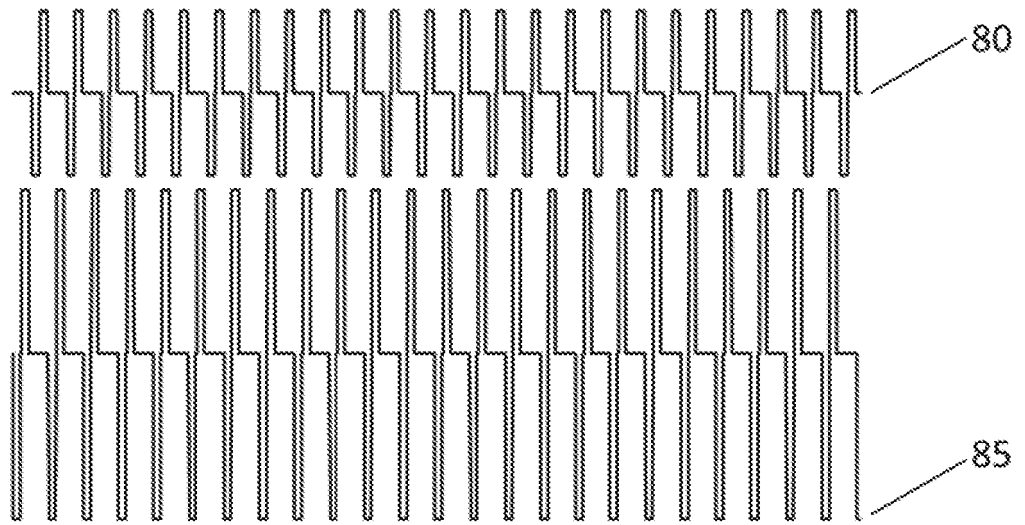

Figure 8

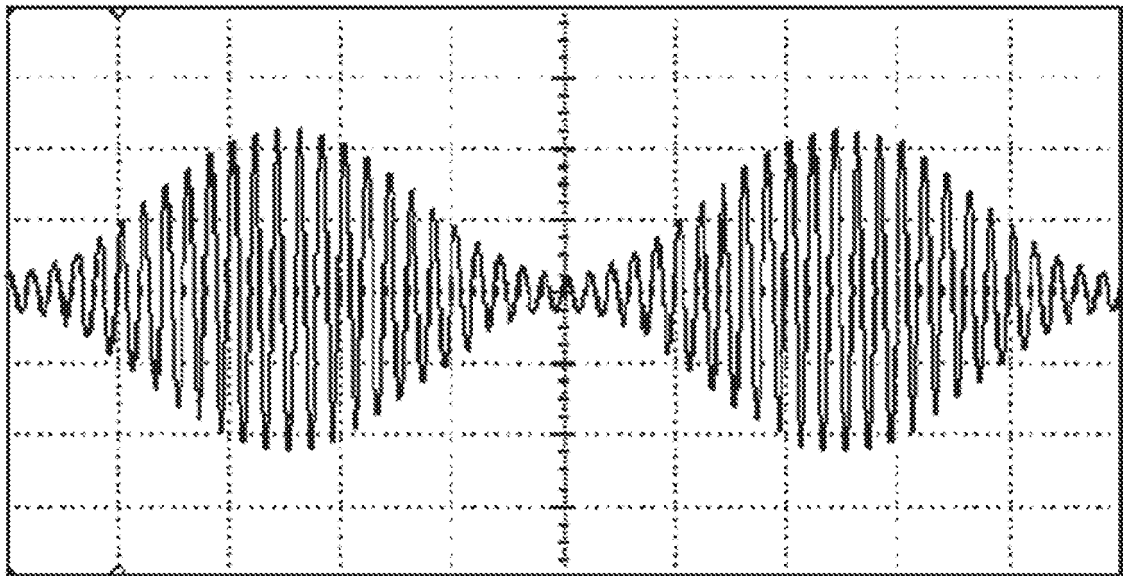

Figure 9

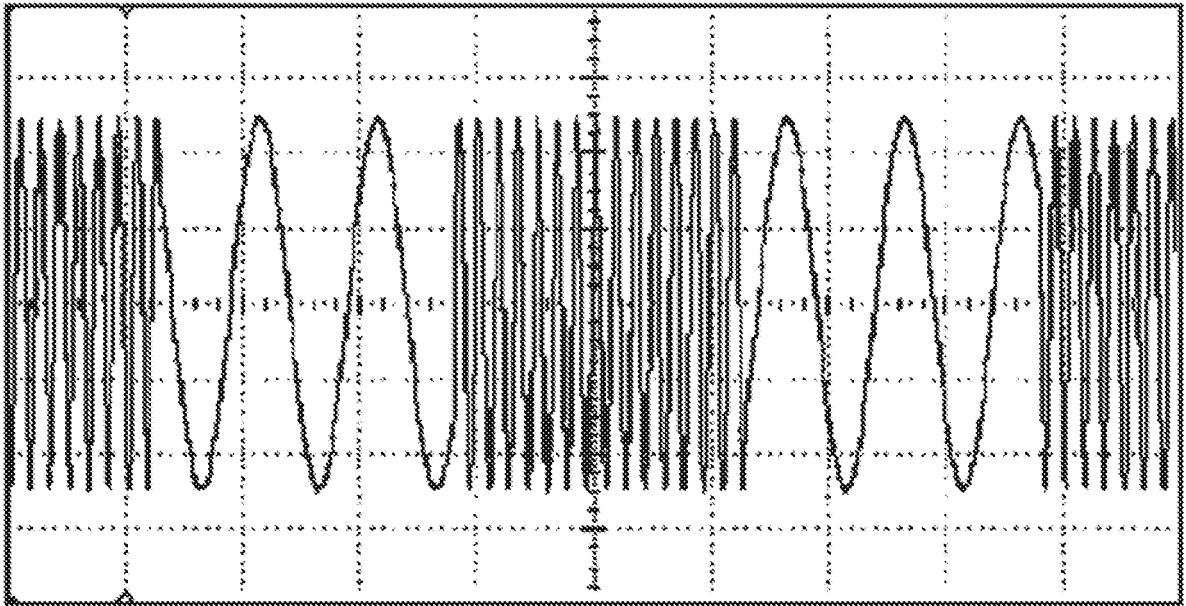

Figure 10

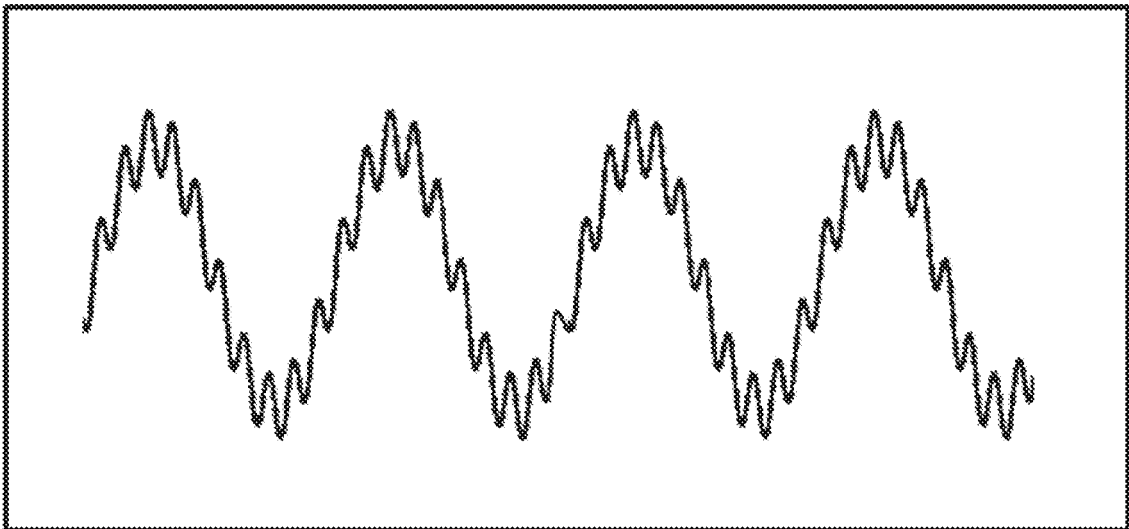

Figure 11

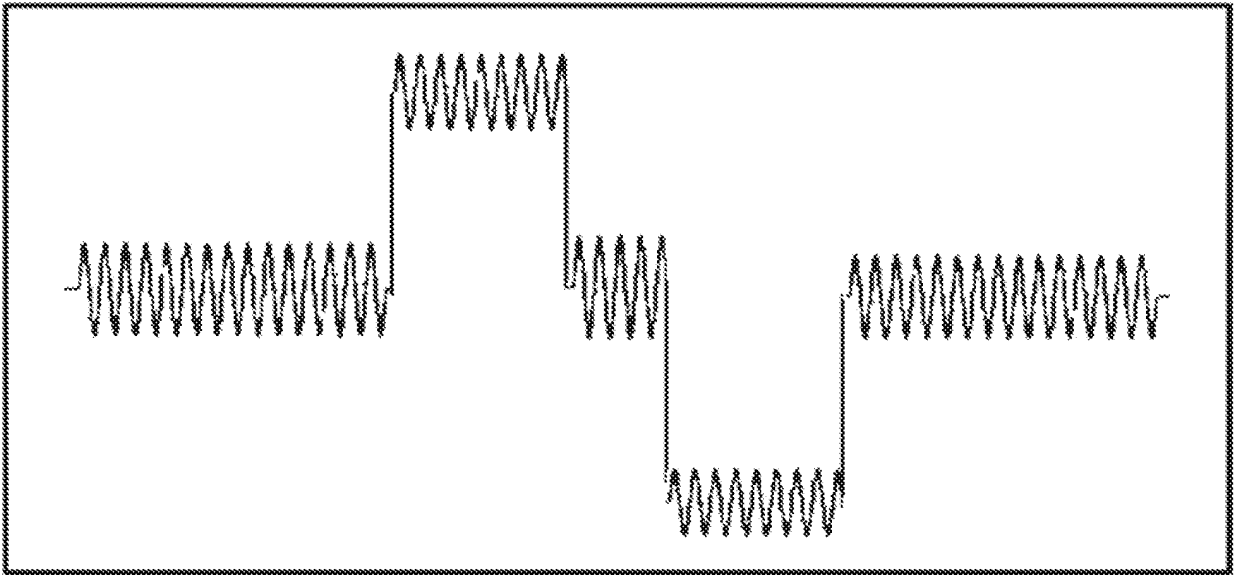

Figure 12

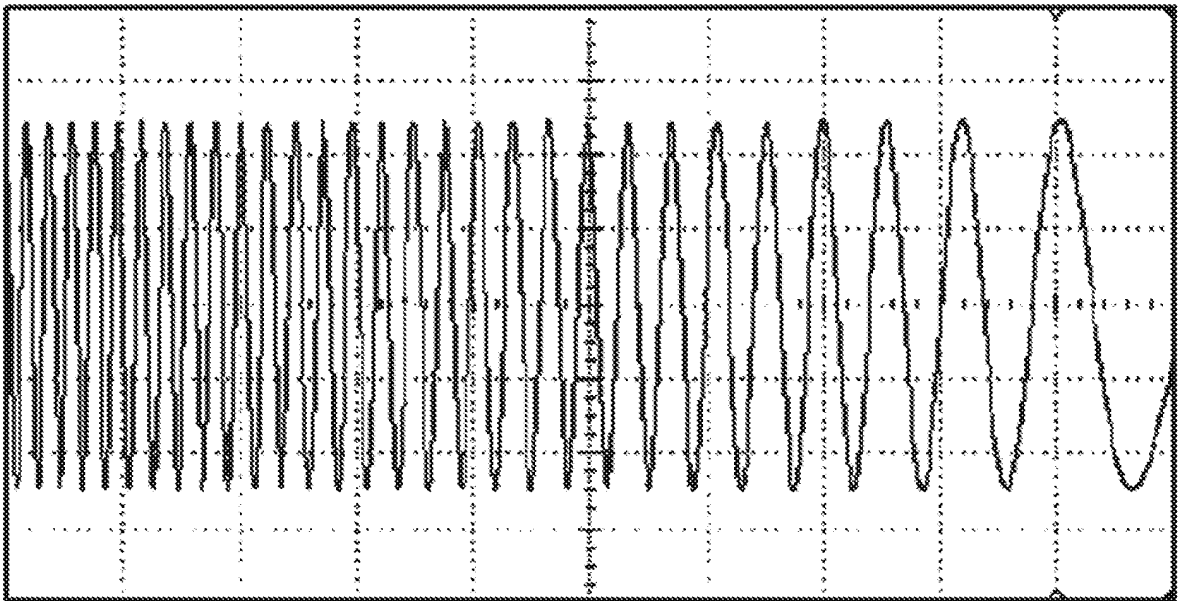
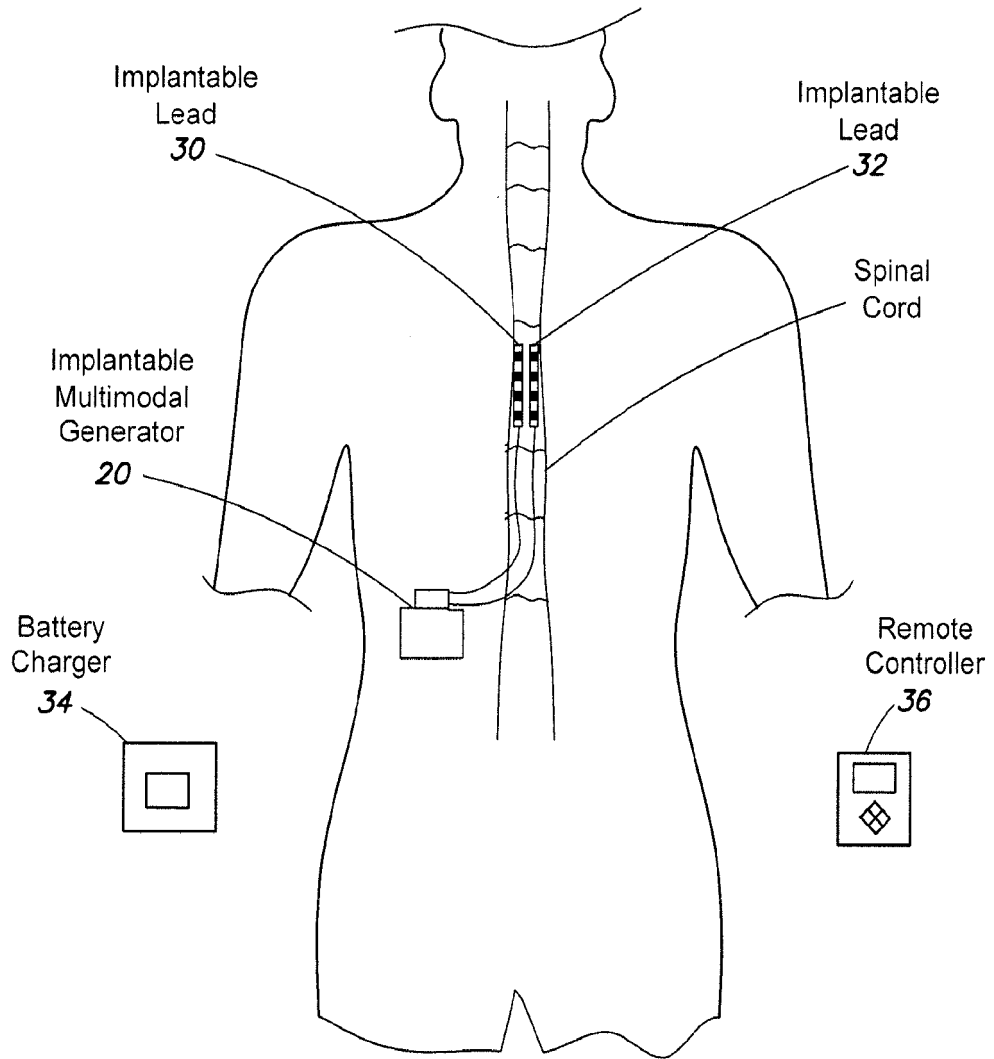
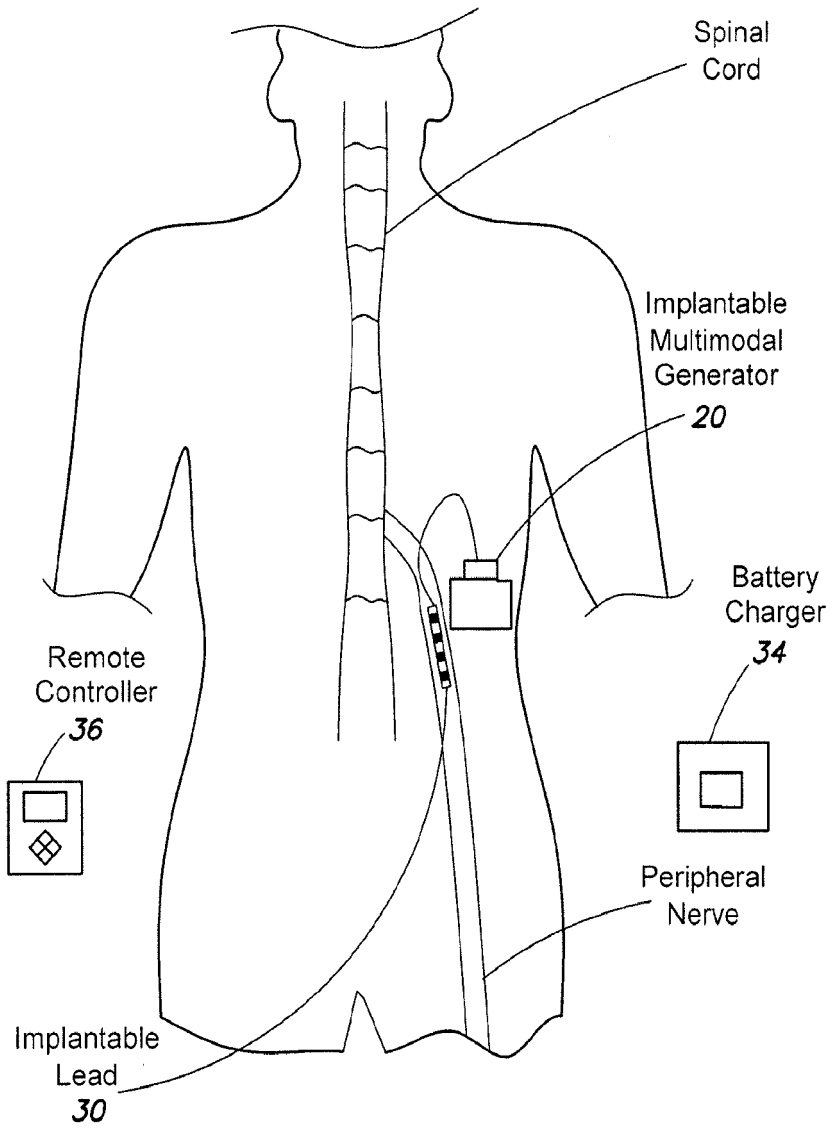

Figure 13



**FIG. 14**



**FIG. 15**



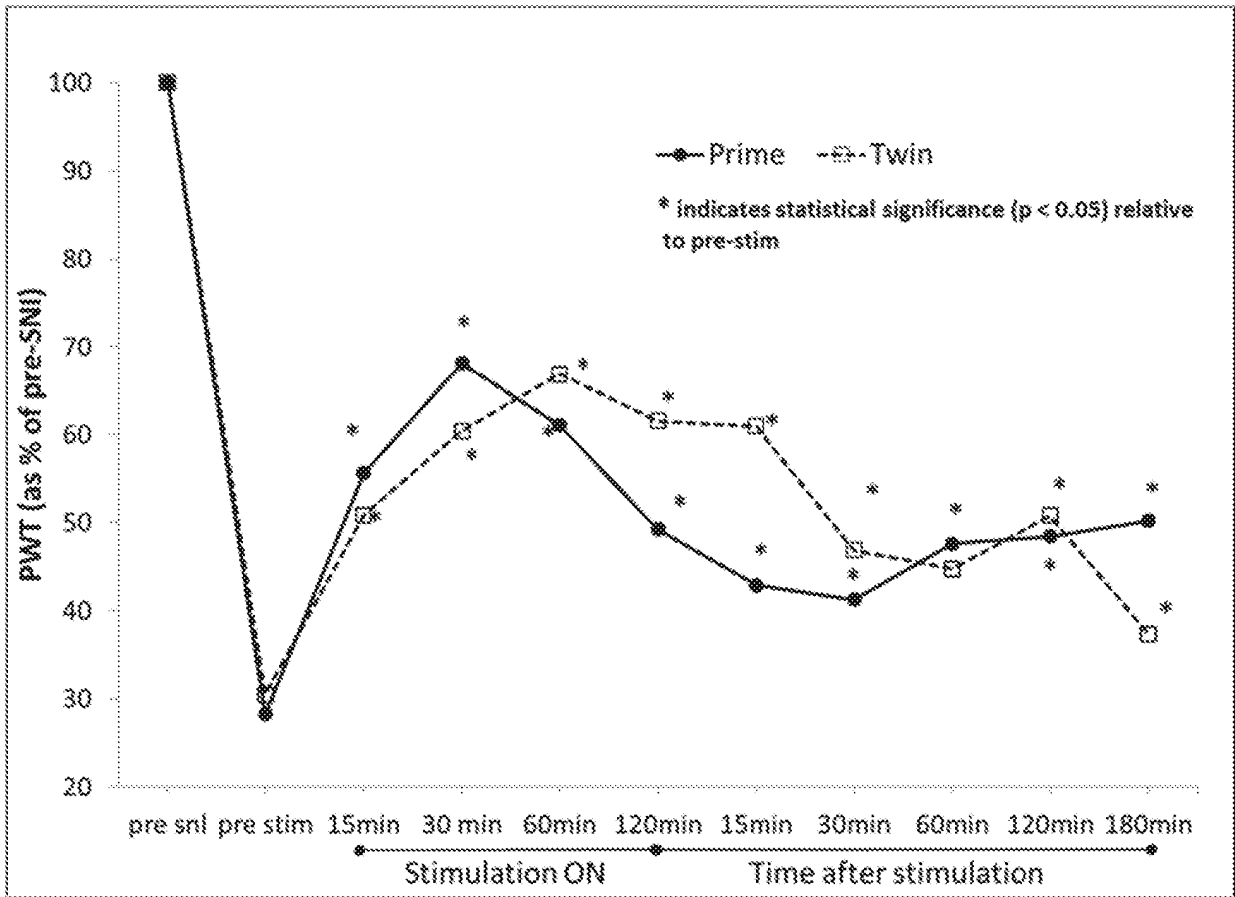

Figure 16

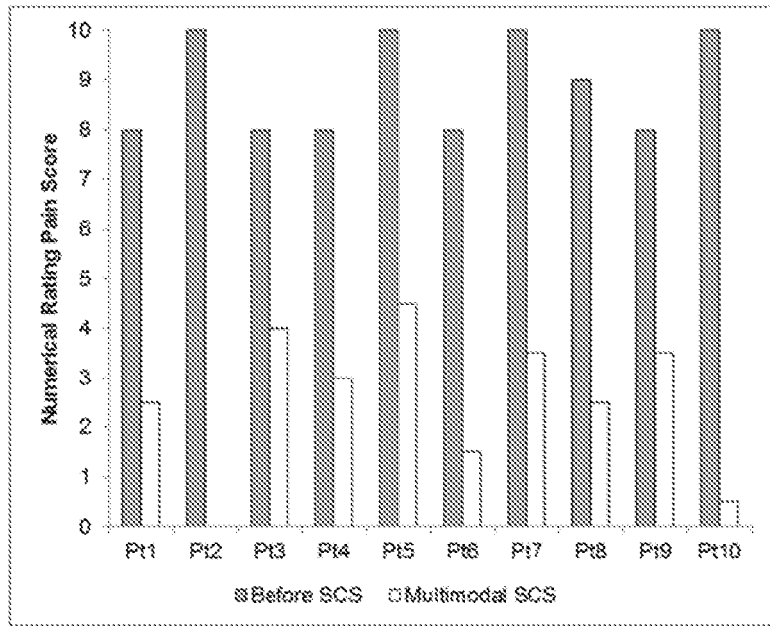

Figure 17A

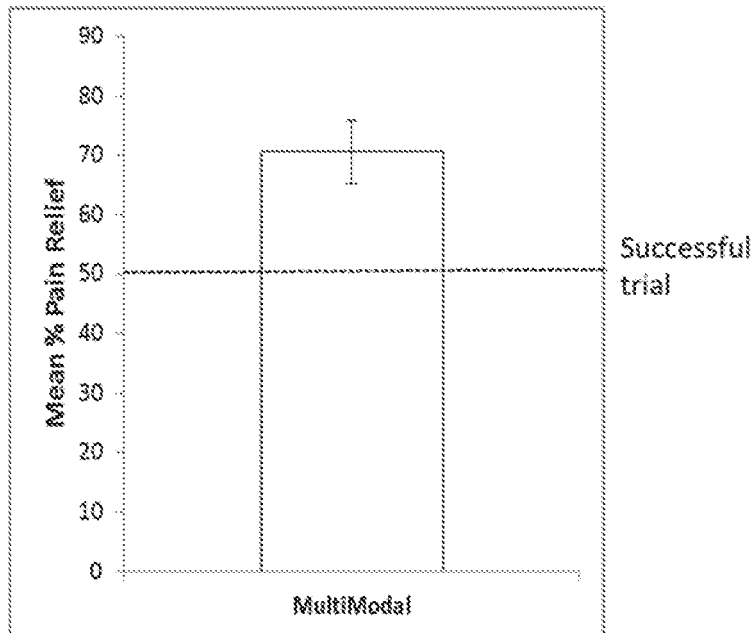

Figure 17B



Figure 18



Figure 19

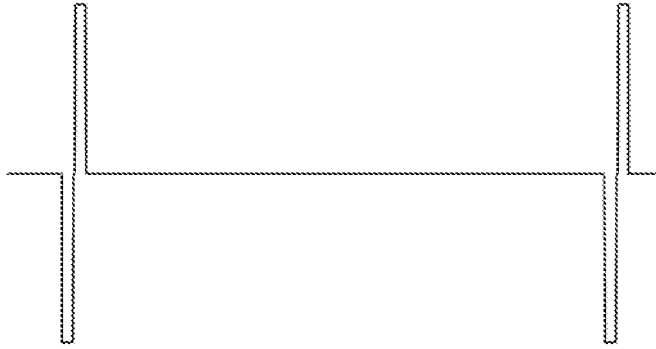

Figure 20



Figure 21

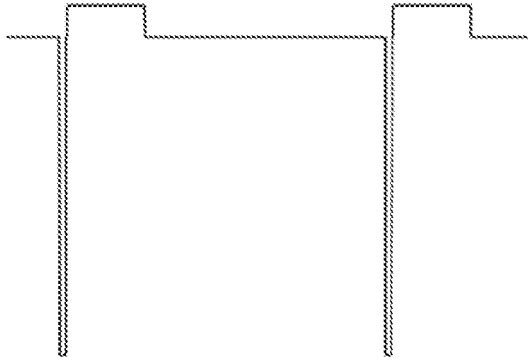

Figure 22

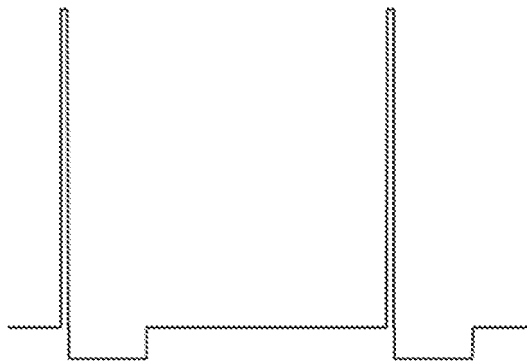

Figure 23

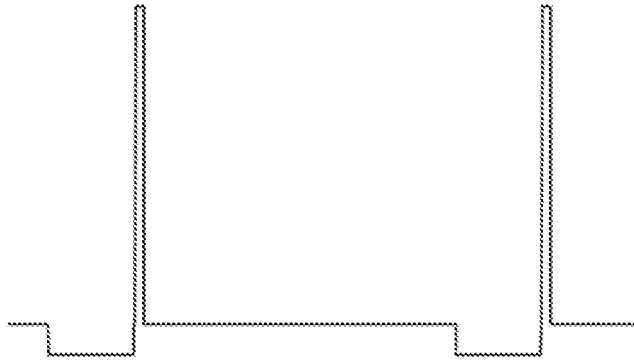

Figure 24

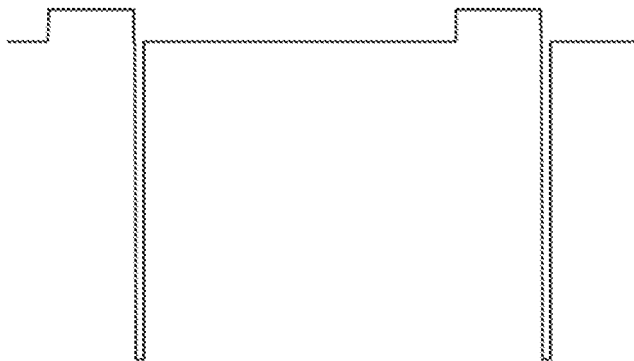

Figure 25



Figure 26

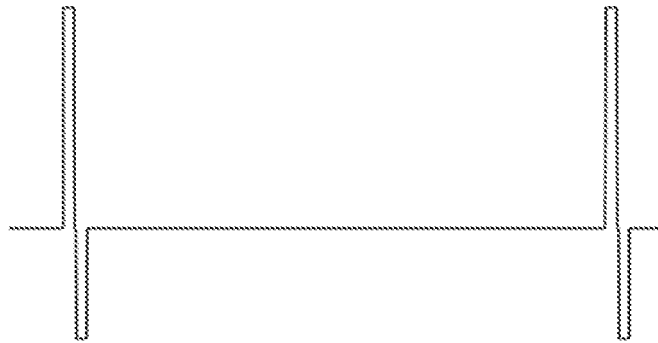

Figure 27



Figure 28

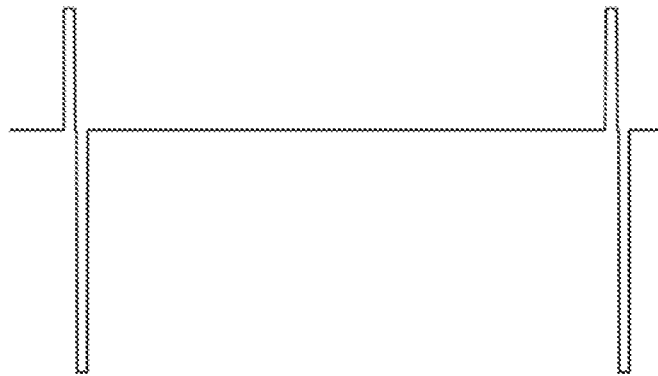

Figure 29



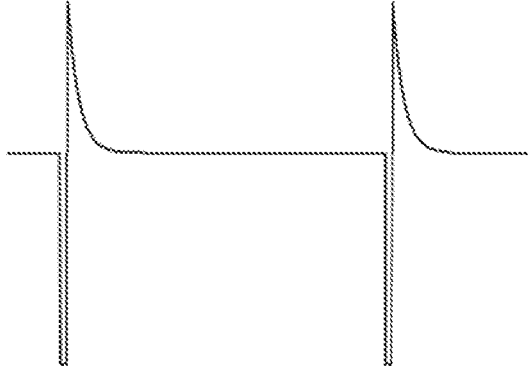

Figure 30

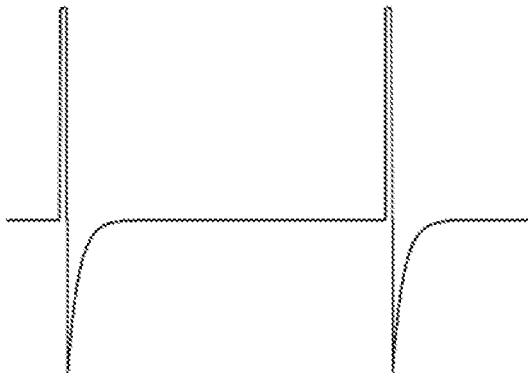

Figure 31

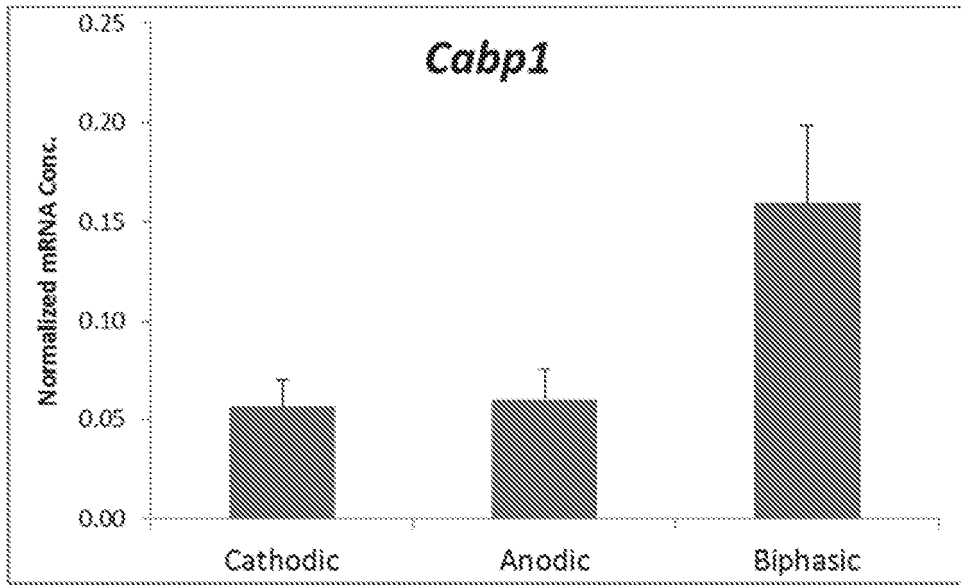

Figure 32A

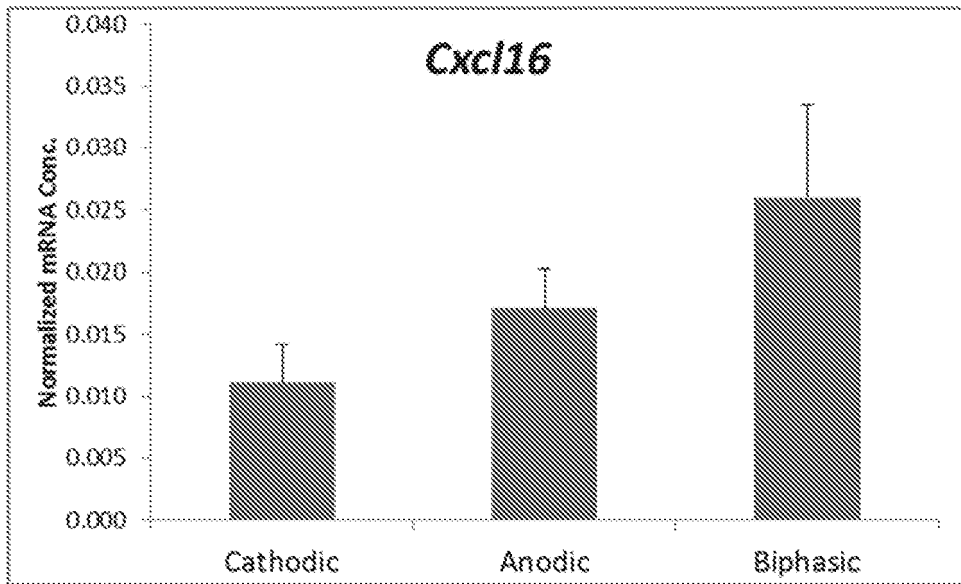

Figure 32B

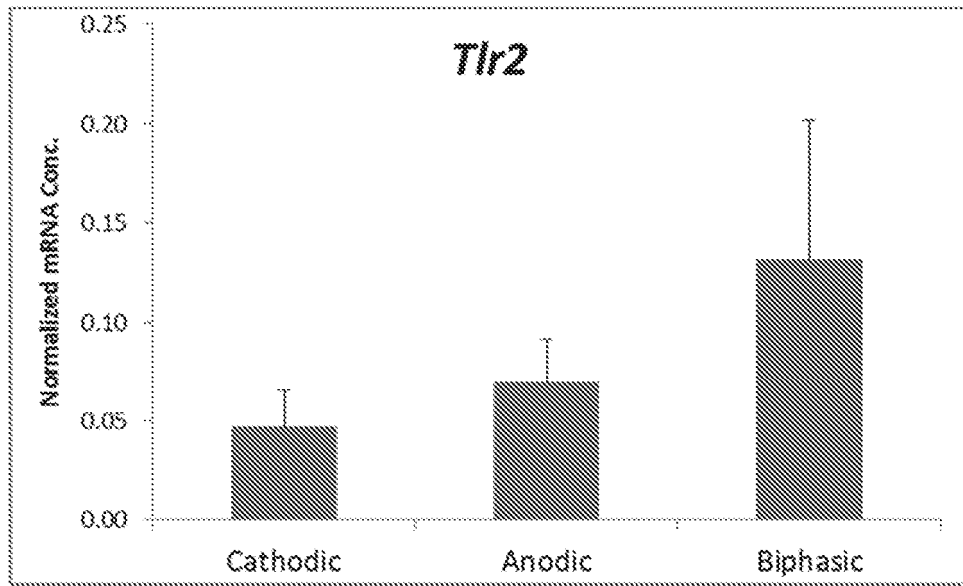

Figure 32C

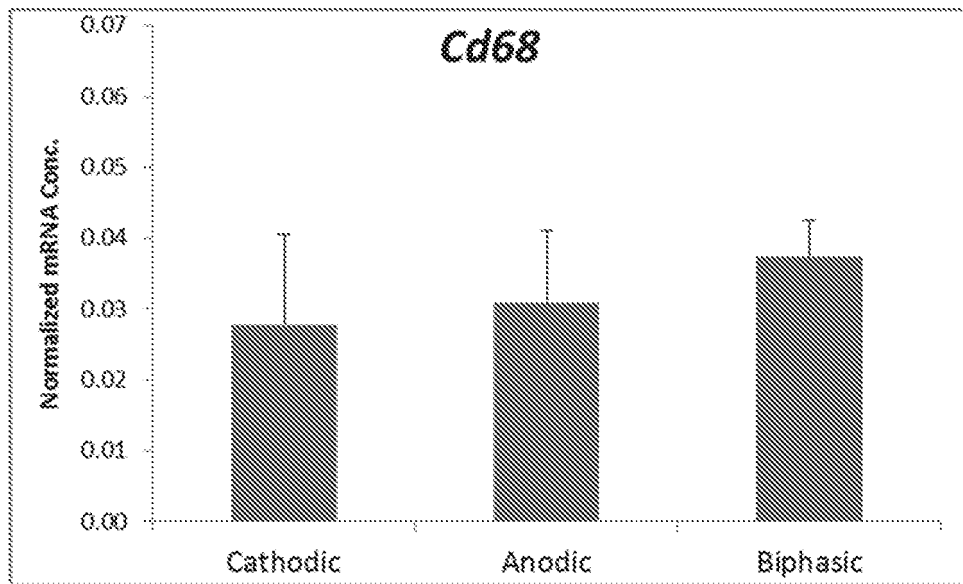

Figure 32D

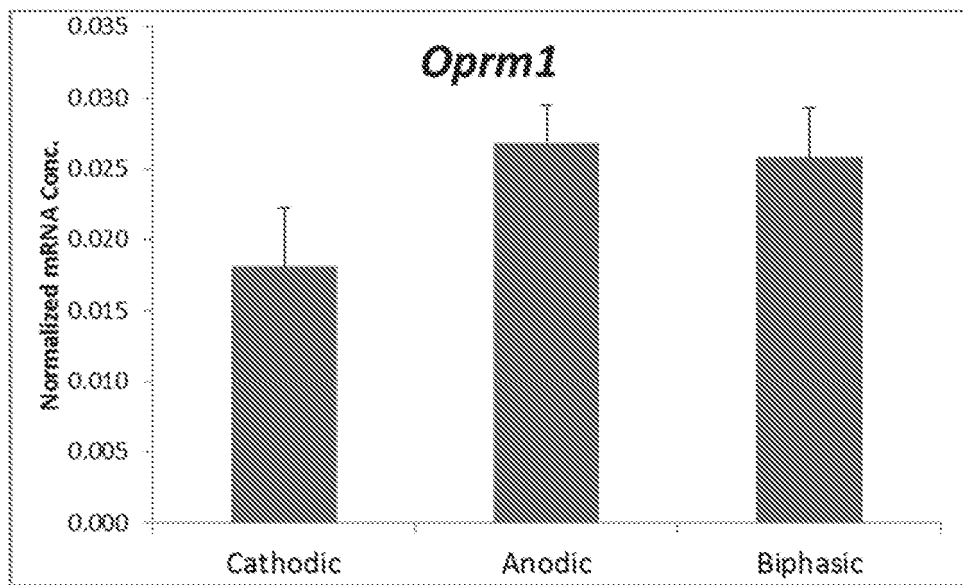

Figure 32E

**REFERENCES CITED IN THE DESCRIPTION**

*This list of references cited by the applicant is for the reader's convenience only. It does not form part of the European patent document. Even though great care has been taken in compiling the references, errors or omissions cannot be excluded and the EPO disclaims all liability in this regard.*

**Patent documents cited in the description**

- US 2013035745 A1 [0002]
- US 2014277265 A1 [0002]