



(11) **EP 3 533 130 B1**

(12) **EUROPEAN PATENT SPECIFICATION**

(45) Date of publication and mention of the grant of the patent:  
**10.06.2020 Bulletin 2020/24**

(21) Application number: **17794088.9**

(22) Date of filing: **27.10.2017**

(51) Int Cl.:  
**H02J 7/00<sup>(2006.01)</sup> B64C 39/00<sup>(2006.01)</sup>**

(86) International application number:  
**PCT/IB2017/056701**

(87) International publication number:  
**WO 2018/078588 (03.05.2018 Gazette 2018/18)**

(54) **AUTOMATED DRONE CHARGING STATION**

**AUTOMATISIERTE LADESTATION FÜR DROHNEN  
STATION DE CHARGE DE DRONE AUTOMATISÉE**

(84) Designated Contracting States:  
**AL AT BE BG CH CY CZ DE DK EE ES FI FR GB  
GR HR HU IE IS IT LI LT LU LV MC MK MT NL NO  
PL PT RO RS SE SI SK SM TR**

(30) Priority: **28.10.2016 PCT/IB2016/056535**

(43) Date of publication of application:  
**04.09.2019 Bulletin 2019/36**

(73) Proprietor: **Telefonaktiebolaget LM Ericsson  
(PUBL)  
164 83 Stockholm (SE)**

(72) Inventors:  
• **FARRAHI MOGHADDAM, Reza  
Brossard, Québec J4Y 2T2 (CA)**

- **FARRAHI MOGHADDAM, Fereydoun  
Brossard, Québec J4W 2E5 (CA)**
- **LEMIEUX, Yves  
Kirkland, Québec H9H 4M1 (CA)**
- **MONETTE, Denis  
Coteau de Lac, Québec JOP 1BO (CA)**

(74) Representative: **Ericsson  
Patent Development  
Torshamnsgatan 21-23  
164 80 Stockholm (SE)**

(56) References cited:  
**WO-A1-2016/137982 KR-B1- 101 599 423  
US-A1- 2016 001 883 US-A1- 2016 311 329**

**EP 3 533 130 B1**

Note: Within nine months of the publication of the mention of the grant of the European patent in the European Patent Bulletin, any person may give notice to the European Patent Office of opposition to that patent, in accordance with the Implementing Regulations. Notice of opposition shall not be deemed to have been filed until the opposition fee has been paid. (Art. 99(1) European Patent Convention).

## Description

### TECHNICAL FIELD

**[0001]** The present disclosure relates to drone charging systems, and in particular, to a drone charging station that is configured to charge multiple drones at the same.

### BACKGROUND

**[0002]** When designing a drone charging system, a number of design constraints must be considered. For example, there are strict constraints on the size, weight and battery capacity that a drone can have. These constraints will, in turn, affect the size and structure of the drone charging station. Thus, a large drone charging station may provide difficulties if space is limited. Further, current drone charging systems require manual intervention during the charging process. Thus, in addition to space constraints being a consideration, manpower constraints must also be considered when designing an optimal drone charging station.

**[0003]** Drone charging stations are typically designed to charge a single drone at a time. Existing charging stations are often not equipped to handle simultaneous charging of drones. However, scenarios often arise where more than one drone in the area near a charging station needs to be charged. A charging station that charges a first drone while other nearby drones have to wait until the first drone is fully charged, is impractical and inefficient. The waiting drones are not being used and are using up energy in the waiting process. Alternately, the waiting drones could search for an alternate charging station. There may not be a station close by or the process of searching for a nearby charging station might put excess strain on the drone's battery capacity. In instances where a charging station may have multiple charging pads to accept multiple drones, the result is a drone charging station with a huge footprint, making it impractical for use at charging facilities with limited available space.

**[0004]** International patent application publication number WO 2016/137982 A1 describes an unmanned aerial vehicle (UAV) and a stand for launching, landing, testing, refueling and recharging the UAV. Further, the patent discloses methods for launching, landing and testing the UAV and the stand.

### SUMMARY

**[0005]** The present disclosure advantageously provides a drone charging station and a system for charging at least one drone. According to one aspect of the disclosure a drone charging station configured to charge at least one drone, is provided. The drone charging station includes at least one charging stack comprised of a plurality of blocks, each of the plurality of blocks sized to engage with the at least one drone, the at least one charging

ing stack including a first conductor block having a first polarity for electrically engaging with a corresponding first electrode of the at least one drone, the first conductor block having a first drone guiding portion, a second conductor block having a second polarity different from the first polarity for electrically engaging with a corresponding second electrode of the at least one drone, the second conductor block having a second drone guiding portion, and an insulator block positioned between the first conductor block and the second conductor block, the insulator block having a third drone guiding portion. The first drone guiding portion, the second drone guiding portion and the third drone guiding portion being arranged to provide a drone guiding path along the at least one charging stack.

**[0006]** According to one embodiment of this aspect, the first drone guiding portion comprises a first thread, the second drone guiding portion comprises a second thread, and the third drone guiding portion comprises a third thread, and wherein the drone guiding path comprises a continuous drone guiding thread formed by an arrangement of the first thread, the second thread and the third thread. According to another embodiment of this aspect, the arrangement includes a starting point of the third thread being positioned proximate an ending point of the first thread and a starting point of the second thread being positioned proximate an ending point of the third thread. According to another embodiment of this aspect, the first drone guiding portion comprises a first plurality of pins, the second drone guiding portion comprises a second plurality of pins, and the third drone guiding portion comprises a third plurality of pins, and wherein the drone guiding path is formed by an arrangement of the first plurality of pins, the second plurality of pins and the third plurality of pins.

**[0007]** According to another embodiment of this aspect, the drone charging station is configured to charge a plurality of drones at the same time. According to another embodiment of this aspect, the drone charging station further includes an accessory block having an end affixed to an end of one of the at least one charging stack, the accessory block being tapered toward the end opposite the end affixed to the end of one of the at least one charging stack. According to another embodiment of this aspect, the drone charging station further includes a plurality of charging stacks resulting in a plurality of first conductor blocks, a plurality of second conductor blocks and a plurality of insulator blocks, the drone charging station further including:

an alignment element configured to align each of the plurality of first conductor blocks, second conductor blocks and insulator blocks to form a cylinder, a first conductor coupler, the first conductor coupler electrically coupling each of the plurality of first conductor blocks together, the first conductor coupler being electrically conductive, and a second conductor coupler, the second conductor coupler electrically coupling each of the plurality of second conductor blocks together, the second conductor

coupler being electrically conductive.

**[0008]** According to another embodiment of this aspect, the drone charging station includes an insulator coupler, the insulator coupler coupling each of the plurality of the insulator blocks together. According to another embodiment of this aspect, each of the plurality of first conductor blocks, second conductor blocks, and insulator blocks include an alignment tab extending within an interior of the cylinder, the alignment tab including at least an alignment aperture sized to receive the alignment element. According to another embodiment of this aspect, each of the plurality of blocks includes a first end having a first engagement element and a second end having a second engagement element, the first end opposite the second end, wherein the first engagement element is matable with the second engagement element of an adjacent block to prevent rotational misalignment. According to another embodiment of this aspect, the drone guiding path is formed along an exterior of the at least one charging stack.

**[0009]** According to another embodiment of this aspect, the drone charging station further includes at least one insulator stack, the at least one insulator stack comprising at least one insulator block, the at least one insulator stack positioned between one of the at least one charging stack and a second charging stack. According to another embodiment of this aspect, the drone charging station further include at least one motor configured to enable the at least one charging stack to rotate, and a rotation inhibitor to inhibit rotation of the at least one drone when the at least one drone contacts the drone charging station, the at least one drone traveling along the drone guiding path due to the rotation of the at least one charging stack. According to another embodiment of this aspect, the insulator block comprises a plurality of separate insulator members. According to another embodiment of this aspect, the drone charging station further includes a third conductor block for electrically engaging with a corresponding electrode of the at least one drone, and a second insulator block positioned between one of the first conductor block and the third conductor block and the second conductor block and the third conductor block the third conductor block configured to provide data transmission to the at least one drone.

**[0010]** According to another aspect of the disclosure, a drone charging station configured to charge at least one drone is provided. The drone charging station includes at least one hollow charging tube comprised of a plurality of interior blocks, each of the plurality of interior blocks sized to engage with the at least one drone, the at least one hollow charging tube including a first interior conductor block having a first polarity for electrically engaging with a corresponding first electrode of the at least one drone, the first interior conductor block having a first drone guiding portion, a second interior conductor block having a second polarity different from the first polarity for electrically engaging with a corresponding second electrode of the at least one drone, the second interior

conductor block having a second drone guiding portion, and an interior insulator block positioned between the first interior conductor block and the second interior conductor block, the interior insulator block having a third drone guiding portion. The first drone guiding portion, the second drone guiding portion and the third drone guiding portion being arranged to provide a drone guiding path along an interior of the at least one hollow charging tube.

**[0011]** According to an embodiment of this aspect, the first drone guiding portion comprises a first thread, the second drone guiding portion comprises a second thread, and the third drone guiding portion comprises a third thread, and wherein the drone guiding path comprises a continuous drone guiding thread formed by an arrangement of the first thread, the second thread and the third thread. According to an embodiment of this aspect, the arrangement includes a starting point of the third thread being positioned proximate an ending point of the first thread and a starting point of the second thread being positioned proximate an ending point of the third thread. According to an embodiment of this aspect, the first drone guiding portion comprises a first plurality of pins, the second drone guiding portion comprises a second plurality of pins, and the third drone guiding portion comprises a third plurality of pins, and wherein the drone guiding path is formed by an arrangement of the first plurality of pins, the second plurality of pins and the third plurality of pins.

**[0012]** According to an embodiment of this aspect, the drone charging station is configured to charge a plurality of drones at the same time. According to an embodiment of this aspect, the drone charging station further includes an accessory block having an end affixed to an end of one of the at least one hollow charging tube, the accessory block being tapered toward the end opposite the end affixed to the end of one of the at least hollow charging tube. According to an embodiment of this aspect, the drone charging station further includes a plurality of hollow charging tubes resulting in a plurality of first interior conductor blocks, a plurality of second interior conductor blocks and a plurality of interior insulator blocks. The drone charging station further includes an alignment element configured to align each of the plurality of first interior conductor blocks, second interior conductor blocks and interior insulator blocks to form a cylinder, a first conductor coupler, the first conductor coupler electrically coupling each of the plurality of first interior conductor blocks together, the first conductor coupler being electrically conductive, and a second conductor coupler, the second conductor coupler electrically coupling each of the plurality of second interior conductor blocks together, the second conductor coupler being electrically conductive.

**[0013]** According to an embodiment of this aspect, the drone charging station further includes an insulator coupler, the insulator coupler coupling each of the plurality of interior insulator blocks together. According to an embodiment of this aspect, each of the plurality of first inte-

rior conductor blocks, second interior conductor blocks, and interior insulator blocks include an alignment tab extending outside of the cylinder, the alignment tab including an aperture sized to receive the alignment element. According to an embodiment of this aspect, each of the plurality of blocks comprises a first end having a first engagement element and a second end having a second engagement element, the first end opposite the second end, wherein the first engagement element is matable with the second engagement element of an adjacent block to prevent rotational misalignment.

**[0014]** According to an embodiment of this aspect, the drone charging station further includes at least one insulator layer, the at least one insulator layer comprising at least one insulator block, the at least one insulator layer positioned between one of the at least one charging hollow tube and a second hollow charging tube. According to an embodiment of this aspect, the drone charging station further includes at least one motor configured to enable the at least one hollow charging tube to rotate, and a rotation inhibitor to inhibit rotation of the at least one drone when the at least one drone enters the drone charging station, the at least one drone traveling along the drone guiding path due to the rotation of the at least one hollow charging tube.

**[0015]** According to another aspect of the disclosure, a system for charging at least one drone is provided. The system includes at least one drone, each of the at least one drone including a first electrode for electrically engaging with a corresponding first conductor block in the drone charging station, the first electrode including a first guiding region, a second electrode for electrically engaging with a corresponding second conductor block in the drone charging station, the second electrode including a second guiding region, and an insulator, the insulator including a third guiding region. The system further including a guiding system comprising at least a portion of the first guiding region, the second guiding region, and the third guiding region, the guiding system configured to engage a corresponding guiding region of the drone charging station in order provide a drone guiding path along the drone charging station.

**[0016]** According to an embodiment of this aspect, the first guiding region, the second guiding region, and the third guiding region are recesses, each of the recesses configured to engage a corresponding thread of the drone charging station. According to an embodiment of this aspect, the drone guiding path is along an exterior of the drone charging station. According to an embodiment of this aspect, each of the at least one drone further comprises a mounting aperture configured to allow the at least one drone to travel past a mounting arm that affixes the drone charging station to a surface.

**[0017]** According to an embodiment of this aspect, each of the at least one drone comprises a receiving region sized to receive an outer perimeter of the drone charging station. According to an embodiment of this aspect, the first guiding region, the second guiding region,

and the third guiding region being disposed within at least a portion of the receiving region. According to an embodiment of this aspect, each of the at least one drone is sized to fit within an interior of the drone charging station, and wherein the first electrode, the second electrode, and the insulator portion are each disposed along an exterior region of the at least one drone, the drone guiding path being formed along an interior surface of the drone charging station.

**[0018]** According to another aspect of the disclosure, a drone docking station configured to receive at least one drone is provided. The docking station includes a docking shaft sized to engage with the at least one drone, the docking shaft having a drone entrance end and a drone exit end opposite the drone entrance end, and a drone guiding thread helically encircling an exterior portion of the elongated docking shaft, the drone guiding thread configured to engage with a corresponding guiding region on the at least one drone to allow the at least drone to move along the drone guiding thread from the drone entrance end to the drone exit end.

**[0019]** According to yet another aspect, a drone docking station configured to receive at least one drone includes an elongated docking shaft sized to engage with the at least one drone, the docking shaft having a drone entrance end and a drone exit end opposite the drone entrance end; and a drone guiding thread helically disposed along the elongated docking shaft, the drone guiding thread configured to engage with a corresponding guiding region on the at least one drone to allow the at least drone to move along the drone guiding thread from the drone entrance end to the drone exit end.

**[0020]** According to this aspect, in some embodiments, the elongated docking shaft is formed as a unitary piece. In some embodiments, the drone docking station further includes at least one electrical charging transmitting element for transmitting a wireless charging signal to the at least one drone for charging the at least one drone when the at least one drone is within a range of the wireless charging signal. In some embodiments, the elongated docking shaft has an inner volume, and the at least one electrical charging element is disposed in the inner volume. In some embodiments, the at least one electrical charging transmitting element is formed as part of the drone guiding thread. In some embodiments, the at least one electrical charging transmitting element is an inductive charging antenna. In some embodiments, the at least one electrical charging transmitting element is a resonance charging antenna. In some embodiments, the drone docking shaft has an exterior surface, the drone guiding thread being formed along the exterior surface. In some embodiments, the drone guiding thread extends from the drone entrance end to the drone exit end. In some embodiments, the drone docking station further includes at least one motor configured to enable the elongated docking shaft to rotate for moving the at least one drone along the at least one drone guiding thread. In some embodiments, the drone docking station further

includes at least one electrically conductive surface for contact charging the at least one drone as the drone moves along the drone guiding thread.

**[0021]** According to another aspect of the disclosure, a system for charging at least one drone includes a docking station and at least one drone. In this aspect, the docking station includes an elongated docking shaft sized to engage with the at least one drone, the docking shaft having a drone entrance end and a drone exit end opposite the drone entrance end; and a drone guiding thread helically disposed along the elongated docking shaft, the drone guiding thread configured to engage with a corresponding guiding region on the at least one drone to allow the at least drone to move along the drone guiding thread from the drone entrance end to the drone exit end. In this aspect, each of the at least one drones includes a guiding region, the guiding region arranged to engage a corresponding portion of the drone guiding thread to allow the at least one drone to travel along the drone guiding thread from the drone entrance end to the drone exit end.

**[0022]** According to this aspect, in some embodiments, the elongated docking shaft is formed as a unitary piece. In some embodiments, the docking station further includes at least one electrical charging transmitting element for transmitting a wireless charging signal to the at least one drone for charging the at least one drone when the at least one drone is within a range of the wireless charging signal; and each of the at least one drones includes an electrical charge receiving element for receiving the wireless charging signal. In some embodiments, the electrical charge receiving element is disposed adjacent the guiding region. In some embodiments, the at least one electrical charge receiving element of the at least one drone is disposed to wirelessly engage the at least one electrical charging transmitting element of the drone docking station, the at least one electrical charging transmitting element of the drone docking station being disposed in an inner volume of the elongated docking shaft. In some embodiments, each of the at least one drone defines a receiving region sized to receive an outer perimeter of the drone charging station such that the at least one guiding region engages the drone guiding thread disposed along the exterior surface of the drone docking shaft. In some embodiments, the at least one electrical charge receiving element of the at least one drone is an inductive charging antenna. In some embodiments, the at least one electrical charge receiving element of the at least one drone is a resonance charging antenna. In some embodiments, each of the at least one drones defines a receiving region sized to receive an outer perimeter of the drone charging station such that the at least one guiding region engages the drone guiding thread formed along an exterior surface of the drone docking shaft. In some embodiments, the guiding system is configured to move the at least one drone along the drone guiding thread by at least one motor configured to rotate the elongated docking shaft. In some embodi-

ments, the docking station further comprises at least one electrically conductive surface disposed to contact charge at least one electrode disposed on the at least one drone as the drone moves along the drone guiding thread.

**[0023]** According to another aspect, a drone docking station configured to receive at least one drone includes a docking shaft sized to engage with the at least one drone, the docking shaft having a drone entrance end and a drone exit end opposite the drone entrance end; at least one drone guiding portion helically encircling an exterior portion of the docking shaft, the at least one drone guiding portion configured to engage with a corresponding at least one guiding portion on the at least one drone to allow the at least one drone to move along the at least one drone guiding portion of the docking shaft from the drone entrance end to the drone exit end; and at least one electrical charging transmitting element for transmitting a wireless charging signal to the at least one drone for charging the at least one drone when the at least one drone is within a range of the wireless charging signal.

**[0024]** According to this aspect, in some embodiments, the drone guiding portion of the docking shaft is formed as a thread. In some embodiments, the drone guiding portion of the docking shaft is formed by protrusions. In some embodiments, the drone docking station further includes at least one motor configured to enable the docking shaft to rotate for moving the at least one drone along the at least one drone guiding portion.

#### BRIEF DESCRIPTION OF THE DRAWINGS

**[0025]** A more complete understanding of the present embodiments, and the attendant advantages and features thereof, will be more readily understood by reference to the following detailed description when considered in conjunction with the accompanying drawings wherein:

FIG. 1 is a front perspective view a drone charging station, in accordance with the principles of the present disclosure;

FIG. 2 is a top view of a drone that is to be charged by the drone charging station in accordance with the principles of the present disclosure;

FIG. 3 is a perspective view of multiple drones being received by the charging stack at the same time and charged in accordance with the principles of the present disclosure;

FIG. 4 is a perspective view of a base block of the drone charging station of the present disclosure;

FIG. 5 is a top view of the base block of the drone charging station illustrating a thread arrangement according to one embodiment of the present disclosure;

FIG. 6 is a perspective view of an arrangement of base blocks of the drone charging station including

a first conductor block, a second conductor block and an insulator block in between according to one embodiment of the present disclosure;

FIG. 7 is a top view of the arrangement of base blocks of FIG. 6;

FIG. 8 is a perspective view of an arrangement of base blocks of the drone charging station showing alignment elements and coupling elements according to one embodiment of the present disclosure;

FIG. 9 is a front perspective view of an arrangement of base blocks of the drone charging station including the conductor/insulator/conductor block arrangement and an additional insulator blocks according to one embodiment of the present disclosure;

FIG. 10 is a perspective view of a portion of the inner aperture of the drone showing inner grooves for mating with the thread arrangement of the drone charging station according to one embodiment of the present disclosure;

FIG. 11 is a front cut-away view showing the engagement of the drone guiding region with the drone charging station guiding threads according to one embodiment of the present disclosure;

FIG. 12 is a front cut-away view showing the interlocking between base blocks in order to cylindrically align the base blocks and prevent rotational misalignment according to one embodiment of the present disclosure;

FIG. 13 is a perspective view of a portion of the drone charging station with a mounting element to enable the drone charging station to be mounted to a surface according to one embodiment of the present disclosure;

FIG. 14 is a perspective view of the drone charging station with a cone-shaped element to facilitate entrance and exit of the drones with respect to the drone charging station according to one embodiment of the present disclosure;

FIG. 15 is a top view of a drone and a lock plate that prevents the drone from rotating with respect to the drone charging station according to one embodiment of the present disclosure;

FIG. 16 is a front cut-away view of multiple drones in the drone charging station where each drone includes a lock plate according to one embodiment of the present disclosure;

FIG. 17 is a perspective cut-away showing a drone being charged inside a hollow charging tube according to one embodiment of the present disclosure;

FIG. 18 is a block diagram of a controller configured to control the drones as they engage with the drone charging station according to one embodiment of the present disclosure;

FIG. 19 is a perspective view of yet another exemplary drone docking station according to the principles of the present disclosure;

FIG. 20 a perspective view of yet another exemplary drone docking station configured to receive a drone

being charged, via a wireless charging element, inside a hollow charging tube according to one embodiment of the present disclosure;

FIG. 21 is a perspective view of yet another embodiment of a portion of an inner aperture of the drone showing inner grooves for mating with the thread arrangement of the drone docking station and further including an electrical charge receiving element for receiving a wireless charging signal from the drone docking station, according to one embodiment of the present disclosure;

FIG. 22 is a perspective view of another exemplary drone docking station showing an alternative thread arrangement according to one embodiment of the present disclosure; and

FIG. 23 is a perspective view of yet another embodiment of a portion of an inner aperture of the drone showing inner protrusions for mating with the thread arrangement of the drone docking station of FIG. 22, according to one embodiment of the present disclosure.

#### DETAILED DESCRIPTION

**[0026]** Before describing in detail exemplary embodiments, it is noted that the embodiments reside primarily in combinations of apparatus components and processing steps related to a drone charging station that can charge one or more drones at the same time. In one embodiment, the proposed drone charging station has no movable parts and occupies a small footprint due to its cylindrical design. In one embodiment, the drone charging station includes stackable base blocks that are uniform in shape to allow for a cylinder of multiple base blocks to be created by stacking base blocks upon each other. In one embodiment, the charging of multiple drones can occur in a first-in first-out arrangement where drones enter the charging station at one end and exit at the opposite end. The stack of base blocks can be of such a size to receive and charge multiple drones simultaneously. The uniformly-shaped blocks can be disassembled and reused for creation of a new drone charging station, for example, at a different location. The drone charging station of the present disclosure also includes a controller that can facilitate operations of the drone and the drone charging station.

**[0027]** Accordingly, components have been represented where appropriate by conventional symbols in the drawings, showing only those specific details that are pertinent to understanding the embodiments so as not to obscure the disclosure with details that will be readily apparent to those of ordinary skill in the art having the benefit of the description herein.

**[0028]** As used herein, relational terms, such as "first" and "second," "top" and "bottom," and the like, may be used solely to distinguish one entity or element from another entity or element without necessarily requiring or implying any physical or logical relationship or order be-

tween such entities or elements.

**[0029]** In some embodiments, the drone charging station of the present disclosure advantageously provides a stackable set of base blocks where one or more drones can enter the charging station and be stacked on top of each other or situated on the charging station very near each other while charging. Without this feature, a large amount of space must be reserved for a large drone station or multiple drone stations must be maintained in order to separately charge multiple drones.

**[0030]** In some embodiments, the drone charging station can be mounted to a surface such as a wall or ceiling which minimizes unintentional impact on the charging station. The mounting feature also helps to minimize the overall footprint of the charging station.

**[0031]** In some embodiments, the drone charging station provides a stack of base blocks, including conductor and insulator blocks, resulting in a charging station without moveable parts and without any additional electrical parts needed to engage and charge the drones. This results in a less complex and less expensive drone charging station which is less prone to failure.

**[0032]** In some embodiments, guiding/landing logic is used to enable the drone(s) to seamlessly approach the charging station, engage, charge, and then leave the charging station.

**[0033]** In some embodiments, the drone charging station forms a cylindrical stack formed of uniformly-shaped base blocks. The shape of each base block is the same with the only difference being whether some base blocks are conductor (i.e., metal) blocks while other base blocks are insulator (i.e., plastic) blocks. Because the overall design and shape of the structure of each block is the same, the design, manufacture, and mass production of the drone charging station is efficient and cost-effective. Further, the charging station blocks are re-usable, and the stack can be broken down and reassembled for additional use, for example, at a different location.

**[0034]** In some embodiments, the drone charging station provides a first-in-first-out (FIFO) feature, which enables drones that enter the stack at one end to remain on the stack till fully charged before exiting at an opposite end of the stack. Thus, the drones exit the drone charging station in the same order that they entered.

**[0035]** In some embodiments, the ability of the drone charging station to receive and charge multiple drones at the same time allows for a swarm or platoon of drones to be charged and used for specifically-controlled tasks.

**[0036]** Referring now to the drawings, in which like reference designators refer to like elements, there is shown in FIGS. 1-18, an exemplary drone charging station, and its related components, constructed in accordance with the principles of the present disclosure and designated generally as "10." Referring to FIG. 1, charging station 10 may include one or more base blocks 12. In one embodiment, base blocks 12 are of uniform shape and size and may be configured to stack upon each other to form a cylindrically-shaped stack of the kind shown in FIG. 1.

Each base block 12 (base blocks 12a, 12b and 12c are referred to collectively as base blocks 12) is sized to engage one or more drones. There are no restrictions to the number of base blocks that may be used to form the stack of drone charging station 10 so a stack of base blocks may be formed of any height based on the number of drones to be simultaneously charged. As used herein, "base block 12" shall refer to the base blocks of drone charging station 10 without regard to whether the base block is a conductor block or an insulator block.

**[0037]** In one embodiment, there are three different types of base blocks 12 that form charging station 10. A first conductor block 12a is a block made of a conductive material such as metal, and has a first polarity, such as positive (+). The first conductor block 12a electrically engages with a corresponding electrode of the same polarity (i.e., positive) of a drone that has entered charging station 10. A second conductor block 12b is also formed of conductive material such as metal. For charging purposes, conductor block 12b has a second polarity different from the first polarity, i.e., negative (-). In other words, conductor block 12a and conductor block 12b can be fabricated of the same material. In operation, conductor block 12b is electrically connected to a polarity opposite the polarity of conductor block 12a in order to create an electrical drone charging circuit. In operation, the second conductor block 12b electrically engages with a corresponding electrode of the same polarity (i.e., negative) of the drone that has entered drone charging station 10. A third type of base block 12 is an insulator block 12c which is formed of an insulator material such as plastic. It is understood that conductor blocks 12a and 12b do not have to be fabricated entirely of a conductive material such as a metal. Rather, blocks 12a and 12b can be fabricated of any suitable material as long as there is a conductive portion on the exterior to electrically couple with a drone, and so that there is an electrically conductive pathway from the electrical supply to the conductive exterior of the block 12a and 12b.

**[0038]** One or more insulator blocks 12c are situated in between and therefore separate first conductor block 12a and second conductor block 12b. This allows two poles of an electricity source to be connected to two different conductor blocks, e.g., conductor blocks 12a and 12b, which are isolated from each other by an insulator block 12c. An arrangement of a first conductor block 12a/second conductor block 12b/insulator block 12c is referred to herein as a charging stack 15. In the embodiment shown in FIG. 1, drone charging station 10 includes four separate charging stacks 15. The drone charging station 10 of the present disclosure is not limited to any specific number charging stacks 15.

**[0039]** One or more drones may enter the drone charging station 10 either from a first end 14 or a second end 16 and travel from one end of the charging station 10 to another end. During the movement of the drone up (or down) the stack of conductor blocks (12a and 12b), the drone is charged due to the engagement of the drone's

electrodes with a corresponding conductor block of similar polarity of charging station 10. The insulator blocks 12c situated in between the charging stacks 15 serve to delay the charging of the drones as they travel along the stack and also to provide separation between a conductive block 12 in one charging stack 15 and a conductive block 12 in an adjacent charging stack 15. In other words, in one embodiment, the insulator blocks 12c between charging stacks 15 are used to ensure that a drone is only charged within a charging stack 15 and not while spanning different charging stacks 15. In other words, since a drone is not charged when in contact with an insulator block 12c, design constraints are considered in dictating the number of insulator blocks 12c that are used to separate charging stack 15 arrangements. Depending on the drone's battery level and other factors such as the strength of the conductors, size of the drones, and/or size and length of the stack of base blocks 12, a different number of insulator blocks 12c may be used to separate the charging stacks 15, and thus although FIG. 1 illustrates the use of two insulator blocks 12c between each charging stack 15, the present disclosure is not limited to a particular number of insulator stacks 12c used.

**[0040]** The arrangement of first conductor blocks 12a, second conductor blocks 12b, and insulator blocks 12c, are such that a drone that enters charging station 10 at one end, for example, first end 14, and rotatably moves down the stacked blocks 12 of charging station 10 towards the opposite end, for example, second end 16, exits charging station 10 at second end 16 being fully charged or charged to a desired level. Thus, in the illustrative embodiment of FIG. 1, drone charging station 10 may host and simultaneously charge up to four drones. As one drone exits charging station 10, charged, and as the three drones travel down the stack of base blocks 12, a new drone may enter drone charging station 10. Thus, in this continuous fashion, drones may continuously enter drone charging station 10 at one end, e.g., first end 14, move down the stack of base blocks 12, obtaining charge along the way, and exit at second end 16 with a desired charge level. The speed at which the drones proceed along the charging station 10 can establish the charging level. Once the top charging stack 15 is free of drones, i.e., with the drone that occupied the top charging stack 15 having moved to the next charging stack 15, a new drone can enter drone charging station 10 at the top charging stack 15 and begin its charging process in the manner described above. As will be discussed below, a controller can be used to control the movement of the drones in such a fashion that charging station 10 can receive and charge the maximum or optimal number of drones without the drones colliding and achieving a desired charge level. As will also be discussed in greater detail below, each base block 12 has a guiding portion such that when the base blocks 12 are stacked in the arrangement of FIG. 1, a drone guiding path 17 is formed around the exterior surface of drone charging station 10. It is the drone guiding path 17 that engages with a cor-

responding guiding region of the drones, allowing the drones to make their way down, or up, the drone charging station 10. In one embodiment, drone guiding path 17 is in the form of a continuous helical thread from one end of drone charging station 10 to its opposite end.

**[0041]** FIG. 2 is a top view of a drone 18 that may be charged by drone charging station 10. Drone 18 includes a center portion 20, four propellers 22, each extending from center portion 20 by an attachment member 24. The attachment members 24 may be rotatable, and/or moveable up/down or left/right to accommodate areas of the drone's flight that might require a smaller drone footprint. Drone 18 includes a mounting aperture 26 configured to allow drone 18 to travel past a mounting mechanism that affixes drone charging station 10 to a surface, as discussed in further detail below. Mounting aperture 26 can be sized and configured to accommodate differently sized charging station mounting mechanisms. Drone 18 also includes a receiving region 28 sized to receive an outer perimeter of drone charging station 10. Similarly, receiving region 28 may be configured in size and shape according to the size and shape of the base blocks 12 of drone charging station 10. Base blocks 12 having a larger diameter will result in the receiving region 28 having a larger diameter in order to fit around and engage the base blocks 12 of drone charging station 10. Although receiving region 28 shown in FIG. 2 is centrally located in center portion 20 of drone 18, it is within the scope of the present disclosure that receiving region 28 can be located off-center, i.e., closer to one of the side edges of center portion 20, and need not be located in the orientation depicted in FIG. 2.

**[0042]** As is shown in different figures and discussed in greater detail below, each drone 18 includes a first electrode and a second electrode, where the first and second electrodes are engageable with corresponding conductor blocks of drone charging station 10 of identical polarity. The electrodes of drone 18 are disposed in layers at least partially around receiving region 28 such that as drone 18 enters charging station 10 and begins to wind its way along (from one end to the opposite end) the stack of base blocks 12, an electrode of, for example, positive polarity, that is at least partially exposed along receiving region 28 contacts a corresponding first conductor block 12a of identical polarity and will receive a charge. Similarly, an electrode of negative polarity at least partially exposed along receiving region 28 receives a charge from second conductor block 12b as drone 18 winds its way along (from one end to the opposite end) drone charging station 10. In this fashion, the electrodes of drone 18 are fully charged by the time drone 18 exits charging station 10.

**[0043]** As also will be discussed in greater detail below, drone 18 includes an arrangement of guiding regions in the form of, for example, inner recesses, nut threads, or grooves disposed at least partially along receiving region 28. These inner recesses or grooves are configured to receive drone guiding path 17 that is formed along the



outer surface of drone charging station 10. In this fashion, as drone 18 rotates and moves from one end of drone charging station 10, for example, first end 14, to the opposite end, for example end 16, it is charged in the fashion described above. The interaction of drone guiding path 17 and the drone's guiding region operates like a screw having outer threads (i.e., drone guiding path 17) and a nut having corresponding inner threads (i.e., the drone's guiding region) to allow drone 18 to travel along drone guiding path 17.

**[0044]** FIG. 3 illustrates an embodiment of the present disclosure where a plurality of drones 18 interact with drone charging station 10 at the same time. As shown, two drones 18 are engaged with drone charging station 10 and are being charged at the same time, while a third drone 18, after having been fully charged, exits drone charging station 10, having helically wound their way along drone guiding path from one end to the opposite end of drone charging station 10. As shown, receiving region 28 of each drone 18 engages with the stack of base blocks 12 of drone charging station 10. Due to the arrangement of drone guiding path 17 and the interaction of drone guiding path 17 with the interior guiding region of each drone 18, each drone 18 rotates in the direction of the arrows and works its way down drone charging station 10. The direction of rotation shown in FIG. 3 is exemplary only and the drones may rotate in the opposite direction, based on the orientation of drone guiding path 17. In other words, it is contemplated that drones 18 can proceed through the charging station 10 from bottom to top, left to right, right to left, etc.

**[0045]** As discussed above, positive electrodes of drone 18 are coupled with corresponding first conductor blocks 12a and negative electrodes are coupled with corresponding second conductor blocks 12b. The number of charging stacks 15 and insulator blocks 12c between each charging stack 15 is selected in such a fashion that each drone 18 is fully charged when it exits drone charging station 10. The insertion of one or more insulator blocks 12c between each charging stack 15 serves to time and delay the charging effect and separate the drones 18 such that one drone 18 can engage with drone charging station 10 at the same time without hitting or dislodging adjacent drones 18 and to maintain electrical connectivity for charging within a single charging stack 15 and not across multiple charging stacks 15. The result is a drone charging station 10 that provides a first-in-first-out (FIFO) feature, which enables drones 18 that enter drone charging station 10 at one end and to remain on drone charging station 10 till fully charged before exiting at an opposite end of drone charging station 10. Thus, the drones exit drone charging station 10 in the same order that they entered. In one embodiment, shown in FIG. 3, a mounting block 30 is affixed at to top end 14 of drone charging station 10. A mounting arm 32 is affixed to mounting block 30 to allow drone charging station 10 to be affixed to a surface such as a wall.

**[0046]** The following discussion describes further de-

tails about base block 12, including each base block's guiding region, and how the guiding region of each base block 12 interacts with adjacent guiding regions to form drone guiding path 17 along the exterior surface of drone charging station 10.

**[0047]** Referring to FIG. 4, a base block 12 can be seen. Base block 12 seen in FIG. 4 could be, for example, first conductor block 12a, second conductor block 12b, or insulator block 12c. Base block 12 includes an interior region 34 and an exterior region 36. Block 12 also includes a guiding portion 38. Guiding portion 38 is, in one embodiment, in the form of a raised thread which starts along a top portion of the exterior region 36 of base block 12 in a relatively flat orientation coplanar with the top (or bottom) edge of the base block 12, e.g., at starting region 39a, to increase thickness as guiding portion 38 helically winds its way away from the top or bottom edge of the base block to form a rounded thread along the exterior region 36 gradually moving lower along exterior region 36 until thinning and terminating at ending region 39b. The thinning of the guiding portion 38 at the top and bottom edges of the base block 12 allows adjacent base blocks 12 to form a complete, substantially uniform and contiguous guiding portion 38 from base block 12 to an adjacent base block 12. Guiding portion 38 may encircle all of exterior region 36 or only a portion of exterior region 36. Guiding portion 38 is sized to receive a corresponding guiding region of drone 18, as described in greater detail below. It should be noted that the orientation of guiding portion 38 of base block 12 shown in FIG. 4 is exemplary only. Guiding portion 38 may take the form of differently arranged threads, for example, one that winds in the opposite direction than the direction shown in FIG. 4. In other embodiments, guiding portion 38 is made of a series of helically oriented pins or protrusions, rather than continuous helical threads.

**[0048]** Base block 12 also includes an alignment tab 40 which extends into interior region 34 of base block 12. Alignment tab 40 includes an alignment aperture 42 sized to receive an alignment element that functions to coaxially align each of the plurality of first conductor blocks 12a, second conductor blocks 12b and insulator blocks 12c, as shown in FIG. 8 and discussed below. By aligning the base blocks 12, a cylindrically-shaped stack of base blocks 12 can be created, as shown in FIG. 1 which provides a contiguous guiding portion 38 from one end of charging station 10 to the opposite end of charging station 10. Alignment tab 40 also includes a coupler aperture 44 which is sized to receive conductor couplers and insulator couplers as shown in FIG. 8 and discussed below. In one embodiment, each of the coupler apertures 44 includes a series of interior grooves or threads such as nut threads, designed to receive corresponding threads of the conductive couplers, much like the interior threads of a nut receives corresponding outer threads of a screw. The conductive couplers and insulator couplers serve to provide structural strength to the stack of base blocks 12 and to align like base blocks 12 to each other, i.e., align

first conductor blocks 12a with each other, second alignment blocks 12b with each other, and insulator blocks 12c with each other, in the base block stack arrangement of charging station 10 shown, for example, in FIG. 1. The conductor couplers also provide electrical connectivity among conductive blocks of the same polarity, and provide part of an electrical charging circuit when they are connected to a corresponding pole of an electrical charging source.

**[0049]** FIG. 5 illustrates a top view of base block 12 according to an embodiment of the present disclosure. Base block 12 could be first conductor block 12a, second conductor block 12b or insulator block 12c. Base block 12 includes guiding portion 38 which is in the form of a thread that encircles part or all of the outer perimeter of base block 12. Guiding portion 38 is in the form of a raised thread of the type described above and shown in FIG. 4. In this embodiment, guiding portion 38 encircles approximately 240 degrees of base block 12. Thus, FIG. 5 shows an angle of 120 degrees where no guiding portion is present. In one embodiment, a second base block 12 is stacked below base block 12 and the guiding portion 38 of the second base block 12 will align with the guiding portion of base block 12 to form a continuous thread. In other words, the guiding portion 38, i.e. guiding threads, of the lower base block 12 will begin when the guiding portion 38 of the upper base block 12 ends. The third base block 12 can then be stacked below the second base block 12 and its threads aligned as described above. In this fashion, a stack of three base blocks 12, for example the upper base block being first conductor block 12a, the second (next lower) base block 12 being insulator block 12c, and the third (lowest) base block 12 being second conductor block 12b, will have their guiding portions 38 aligned such that a continuous guiding helical thread is formed around 360 degrees of the three-block charging stack 15.

**[0050]** It should be noted that in the thread arrangement described above, there can be overlap among adjacent threads. Thus, a second thread need not start exactly where an adjacent thread has ended. By overlapping the guiding portion 38, or thread, of one base block 12 with the guiding portion 38, or thread, of an adjacent base block 12, a continuous thread can be maintained without the need for exact alignment of the starting point of the thread of one base block 12 with the ending point of an adjacent base block 12. Further, it should be noted that the 120 degree/three block threading arrangement is only one embodiment of the present disclosure. For example, four base blocks 12 each having a guiding portion of 90 degrees can be aligned to form a four-block stack, where, again, a continuous guiding thread of 360 degrees is formed. Any other arrangements can be used, provided the resulting guiding thread is 360 degrees which will allow drone 18 to travel along the continuous thread of drone guiding path 17. Again, as discussed above, as drone 18 travels along guiding path 17, it is being charged when the drone's positive electrode en-

gages first conductor block 12a (which has a positive charge) and when the drone's negative electrode engages second conductor block 12b (which has a negative charge).

**[0051]** FIG. 6 is an illustration of charging stack 15 having a plurality of base blocks 12 that form a portion of the stack of blocks shown in the drone charging station 10 of FIG. 1. Each of the plurality of base blocks 12 are sized to engage with at least one drone 18. Charging stack 15 of FIG. 6 is a three-block configuration that includes first conductor block 12a having a first polarity (i.e., positive), for electrically engaging with a corresponding first (i.e., positive) electrode of drone 18. First conductor block 12a has a corresponding first drone guiding portion 46 that encircles at least a portion of first conductor block 12a in the manner described above. The charging stack of FIG. 6 also includes second conductor block 12b having a second polarity different from the first polarity (i.e., negative), for electrically engaging with a corresponding second (i.e., negative) electrode of drone 18. Second conductor block 12c has a corresponding second drone guiding portion 48 that encircles at least a portion of second conductor block 12c in the manner described above. The charging stack of FIG. 6 also includes insulator block 12c positioned between first conductor block 12a and second conductor block 12b, where insulator block 12c has a third drone guiding portion 50 that encircles at least a portion of insulator block 12c in the manner described above.

**[0052]** In the embodiment shown in FIG. 6, first drone guiding portion 46 is comprised of a first thread, second drone guiding portion 48 is comprised of a second thread, and third drone guiding portion 50 is comprised of a third thread, and wherein drone guiding path 17 comprises a continuous drone guiding thread formed by an arrangement of the first thread, the second thread and the third thread. Drone guiding path 17 is formed by an arrangement of the first, second and third threads to form a continuous 360-degree thread around the three-block stack. A starting point of third drone guiding portion 50, which is the thread of insulator block 12c, is positioned proximate an ending point of the first drone guiding portion 46, which is the thread of first conductor block 12a, and a starting point of second guiding portion 48, which is the thread of second conductor block 12b is positioned proximate an ending point of third thread guiding portion 50, which is the thread of insulator block 12c.

**[0053]** In an alternate embodiment, the continuous threads forming the guiding portions of each base block 12 are replaced by a series of helically oriented pins or other protrusions. Thus, in one embodiment, first drone guiding portion 46 is comprised of a first plurality of pins, second drone guiding portion 48 comprises a second plurality of pins, and third drone guiding portion 50 comprises a third plurality of pins. Thus, drone guiding path 17 is formed by an arrangement of the first plurality of pins, the second plurality of pins and the third plurality of pins.

**[0054]** As discussed above, the angle between the start of a thread at the top of a base block 12 and the end

of a thread at the bottom of an adjacent base block 12 may be, in one embodiment, 120 degrees. This is for a 3-base block formation, which gives a full 360 degrees (or multiple of 360 degree) rotation of the thread. However, the present disclosure is not limited to such an arrangement and other base block arrangements can be used, for example, a four base block arrangement, where the thread angle is 90 degrees. In other words, a 360/n degree for n base block formation may be used.

**[0055]** FIG. 7 is a top view of charging stack 15 in which alignment tabs 40a, 40b and 40c (collectively referred to herein as alignment tabs 40) for three sequential base blocks 12 are shown. First drone guiding portion 46, second drone guiding portion 48 and third drone guiding portion 50 can be seen encircling charging stack 15. FIG. 7 shows the interaction of alignment tabs, where a first alignment tab 40a of first conductor block 12a is displaced with respect to a second alignment tab 40b of second conductor block 12b and a third alignment tab 40c of insulator block 12c, where alignment tab 40c is positioned between first alignment tab 40a and second alignment tab 40b. This arrangement allows alignment tabs 40 of the same type of base block 12 to be longitudinally aligned while allowing alignment tabs 40 of different types of base blocks 12 to be rotationally displaced from one another. As discussed below and shown in FIG. 8, alignment of the alignment tabs 40a, 40b, and 40c allow for an alignment element to be inserted within alignment aperture 42 to such that each of the base blocks 12 of drone charging station 10 do not rotate with respect to each other, i.e., become dislodged or misaligned, which may affect drone guiding path 17, and in turn, how the drones 18 move from one end to the opposite end of drone charging station 10.

**[0056]** FIG. 8 illustrates drone conductor stack 15 which includes first conductor block 12a, second conductor block 12b, and insulator block 12c there between. First drone guiding portion 46, second drone guiding portion 48 and third drone guiding portion 50 are shown to form part of the continuous drone guiding path 17. Alignment element 52, which could be a non-electrically conductive rod or bolt is received in the alignment aperture 42 of each of the blocks of drone conductor stack 15. For example, alignment element 52 is received in alignment aperture 42 of alignment tab 40a of first conductor block 12a, alignment aperture 42 of alignment tab 40b of second conductor block 12b, and alignment aperture 40 of alignment tab 40c of insulator block 12c. Thus, when drone charging station 10 includes a plurality of first conductor blocks 12a, second conductor blocks 12b, and insulator blocks 12c, alignment element 52 is configured to align each of the plurality of first conductor blocks 12a, second conductor blocks 12b and insulator blocks 12c with each other to form an aligned cylinder, as shown in FIG. 1. Thus, alignment element 52 maintains the stability of charging station 10 by preventing the misalignment or unwanted rotation of one of the base blocks 12, with respect to another base block 12.

**[0057]** Further, FIG. 8 also shows first conductor coupler 54, second conductor coupler 56 and insulator coupler 58. First conductor coupler 54 could be in the form of a bolt or screw and is electrically conductive. First conductor coupler 54 is received in a corresponding coupler aperture 44 of alignment tab 40a of first conductor block 12a. As discussed above, in one embodiment, each of the coupler apertures 44 includes a series of interior threads designed to receive corresponding threads of the conductive couplers. In another embodiment, the couplers 54, 56 and 58 may be press fit into the corresponding coupler apertures 44. Thus, first conductor coupler 54 serves to both transfer electricity by electrically coupling each of the plurality of first conductor blocks 12a together, and also serves to keep each of the first conductor blocks 12a aligned with each other. Similarly, second conductor coupler 56 is received in a corresponding coupler aperture 44 of alignment tab 40b of second conductor block 12b. Thus, second conductor coupler 56 serves to both transfer electricity by electrically coupling each of the plurality of second conductor blocks 12b together, and also serves to keep each of the second conductor blocks 12b aligned with each other. FIG. 8 also illustrates an insulator coupler 58, which couples the insulator block 12c with each of the plurality of insulator blocks 12c of drone charging station 10. Thus, conductor couplers 54 and 56, and insulator coupler 58, serve to prevent misalignment or unwanted rotation of like base blocks 12 with respect to each other.

**[0058]** FIG. 9 is a perspective view of an arrangement of base blocks 12 of the drone charging station 10. The arrangement includes charging stack 15, i.e., an arrangement of first conductor block 12a/insulator block 12c/second conductor block 12b, and also includes additional insulator blocks 12c. A portion of drone guiding path 17 is shown winding around the exterior of the stack of base blocks 12a, 12c, and 12b. Drone guiding path 17 includes first guiding path 46, third guiding path 50, and second guiding path 48, which forms a continuous thread to allow one or more drones 18 to work their way from one end of drone charging station 10 to an opposite end, while being charged. As discussed above, the insertion of additional insulator blocks 12c between charging stacks 15 creates spacing to allow multiple drones 18 to be charged by drone charging station 10 at the same time without the drones 18 colliding with one another. Any number of insulator blocks 12c can be used as "spacers." The additional "spacer" insulator blocks 12c each include a respective guiding thread so there is no break in or interruption of drone guiding path 17.

**[0059]** In another embodiment, additional conductors can be added to the 3-base block formation. The additional conductor could be used, for example, for data transfer, for charging at a second voltage or for sensing the level of charge of the drone battery. Thus, additional conductor blocks can be used for the transmission of different voltages to drone 18 for the creation of a wired data channel for higher data transmission. Thus, first con-

ductor 12a can be the first base block 12 in the drone conductor stack 15, followed by an insulator block 12c, followed by second conductor block 12a, followed by another insulator block 12c, followed by a third conductor block 12, which could be used for data transmission to/from drone 18. The orientation can also be reversed, where the first base block 12 represents the third conductor block that is used for data transmission, and the first and second conductor blocks are used for charging a corresponding electrode on drone 18. Additional insulator blocks 12c can then be used for spacing purposes as described above.

**[0060]** Thus, in one embodiment, drone charging station 10 further includes a third conductor block for electrically engaging with a corresponding electrode of drones 18, and a second insulator block positioned between one of the first conductor block 12a and the third conductor block and the second conductor block 12b and the third conductor block. In one embodiment, the third conductor block is configured to provide data transmission to drones 18.

**[0061]** In yet another embodiment, where multiple insulator blocks 12c are used for spacing purposes, as shown in FIG. 9, instead of a stack of multiple individual insulator blocks 12c, a single thicker insulator unit could be used. The single insulator unit could be manufactured to be of the same or similar thickness as a stack of separate, individual insulator blocks 12c, thus providing the same delay or spacing feature as in the individually-stacked insulator block 12c embodiment.

**[0062]** FIG. 10 is a partial view of the receiving region 28 of the center portion 20 of drone 18. As described above, drone 18 includes a first electrode 60, and a second electrode 64 having a polarity different from first electrode 60. Thus, for example, first electrode 60 could be a positive polarity electrode while second electrode 64 may be negative, or vice versa. Drone 18 also includes an insulator region 62 between first electrode 60 and second electrode 64. In operation, when drone 18 is engaged with charging station 10, as the drone rotates along charging station 10, first electrode 60 is electrically engaged with a corresponding first conductor block 12a of the same polarity and a second electrode 64 is electrically engaged with second conductor block 12b of the same polarity, thus allowing drone 18 to sequentially receive an electrical charge as it travels along drone charging station 10. In the embodiment of FIG. 10, a portion of the first electrode 60, the second electrode 64 and the insulator region 62 are disposed around at least a portion of receiving region 28. In one embodiment, receiving region 28 is thick enough to engage with three adjacent charging blocks 12 to allow electrodes 60 and 64 to contact corresponding conductor blocks 12a and 12b within a charging stack 15.

**[0063]** In one embodiment, to enable the coupling of the electrodes of drone 18 with the conductors of drone charging station 10, first electrode 60 includes a first guiding region 66, second electrode 64 includes a second

guiding region 68, and insulator region 62 includes a third guiding region 67. Thus, in one embodiment, the arrangement of guiding regions as shown in FIG. 10, form a guiding system that includes at least a portion of first guiding region 66, second guiding region 68, and third guiding region 67, where the guiding system is configured to engage drone guiding path 17 of drone charging station 10.

**[0064]** In one embodiment, as shown in FIG. 10, first guiding region 66, second guiding region 68, and the third guiding region 67 are recessed threads, where each of the recessed threads are configured to engage a corresponding thread of drone charging station 10, much like threads on a nut engage threads on a screw. The recessed threads are disposed around receiving region 28, such that when drone 18 engages drone charging station 10, the electrodes 60 and 64 of drone 18 are electrically coupled with first conductor block 12a and second conductor block 12b respectively. Further, drone 18 is able to rotate from one end of drone charging station 10 and exit the opposite end due to the engagement of the recessed threads along the interior of receiving region 28 with drone guiding path 17 along the exterior of drone charging station 10.

**[0065]** FIG. 11 illustrates a front, cut-away view showing the engagement of drone 18 with drone charging station 10. As shown, first guiding region 66 of first electrode 60 of drone 18 engages with first drone guiding portion 46 of first conductor block 12a of drone charging station 10. Second guiding region 68 of second electrode 64 engages with second drone guiding portion 48 of second conductor block 12b of drone charging station 10. Third guiding region 67 of insulator 62 of drone 18 engages with third drone guiding portion 50 of insulator block 12c of drone charging station 10.

**[0066]** FIG. 12 illustrates another embodiment of the present disclosure where each of conductor block 12a, conductor block 12b and insulator block 12c of charging stack 15 includes an engagement element to prevent the dislodging or misalignment of the three blocks that form charging stack 15. First conductor block 12a includes a first end 70a, and a second end 72a opposite the first end 70a. Second conductor block 12b includes a first end 70b and a second end 72b opposite first end 70b. Insulator block 12c includes a first end 70c and a second end 72c opposite first end 70c. First conductor block 12a also includes a first engagement element 74a extending from its first end 70a and a second engagement element 76a extending from its second end 72a. Similarly, second conductor element 12b includes a first engagement element 74a extending from its first end 70b and a second engagement element 76b extending from its second end 72b. Insulator element 12c also includes a first engagement element 74c extending from its first end 70c and a second engagement element 76c extending from its second end 72c.

**[0067]** Each engagement element could be in the form of protrusions that interlock with the engagement element of an adjacent block 12 in the form of a finger joint. Thus,

as shown in FIG. 12, second engagement element 76a of first conductor block 12a interlocks with first engagement element 74c of insulator block 12c. Similarly, second engagement element 76c of insulator block 12c engages with first engagement element 74b of second conductor block 12b. If additional insulator blocks 12c are stacked on either side of charging stack 15 as in the arrangement depicted in FIG. 1, each of the additional insulator blocks 12c can interlock with adjacent blocks in a similar manner. Thus, each of the plurality of blocks of drone charging station 10 includes a first end having a first engagement element and a second end having a second engagement element, the first end opposite the second end, wherein the first engagement element is matable with the second engagement element of an adjacent block to prevent rotational misalignment. It is understood that engagement elements are not limited to finger joint-like protrusions and the other types of interlocking arrangements, e.g., "tongue in groove," tabs, etc., may be used.

**[0068]** FIG. 13 illustrates another embodiment of the present disclosure. Drone charging station 10 may be mounted on a surface such as a wall, overhang, or ceiling. FIG. 13 depicts a wall-mounted version of drone charging station 10. Mounting block 30 is added to the stack of blocks of drone charging station 10. Mounting block 30 may be added to the top end of the stack of blocks or to the bottom, or two mounting blocks 30 may be added to drone charging station 10, i.e., one mounting block added to the top end of the stack of blocks and another mounting block 30 added to the bottom end of the stack of blocks. Each mounting block 30 will be mounted to a surface by a corresponding mounting arm 32. Mounting arm 32 is connected at one end to the mounting surface and at its other end to mounting block 30. Mounting arm 32 can be made of a conductive material such as metal to provide electricity to first conductor coupler 54 and second conductor coupler 56 (not shown). If the mounting surface is a ceiling or overhang, i.e., above drone charging station 10, a vertically-oriented mounting arm 32 is affixed to mounting block 30. As described above and shown in FIG. 2, each drone includes mounting aperture 26 which is configured to allow drone 18 to travel past mounting arm 32 that affixes drone charging station 10 to a surface.

**[0069]** FIG. 14 depicts yet another embodiment of the present disclosure. An accessory block 78 having a first end is affixed to an end of drone charging station 10, i.e., multiple charging stacks 15, separated by one or more insulator blocks 12c. In one embodiment, the accessory block 78 is cone-shaped and is tapered toward the end opposite the end affixed to the end of charging stack 15. The use of a tapered, or "cone-shaped" accessory block facilitates the approach and/or exit of the drones 18 by allowing the receiving region 28 of drone 18 to receive the tapered end of accessory block 78. Cone attachment mounting arm 80 is attached at one end to accessory block 78 and at its other end to a surface such as a wall or a ceiling. In one embodiment, two cone-shaped ac-

cessory blocks 78 are added to the stack of blocks of drone charging station 10, i.e., one cone-shaped accessory block 78 is affixed or otherwise mounted upon one end of drone charging station 10 and a second cone-shaped accessory block 78 is affixed or otherwise mounted to the opposite end of the drone charging station 10. In this fashion, both the entrance of the drones 18 upon drone charging station 10 and the exit of the drones 18 from drone charging station 10 is facilitated. Similar to mounting arm 32, cone attachment mounting arm 80 affixed accessory block 78 to a surface. Cone attachment mounting arm 80 may be made of a conductive material such as metal in order to provide electricity to the conductor couplers 54 and 56 (not shown) of drone charging station 10.

**[0070]** FIGS. 15 and 16 illustrate another embodiment of the present disclosure. In this embodiment, drone charging station 10 includes at least one motor (not shown) that can be installed inside drone charging station 10, or for example, either at the bottom or the top of the stack of base blocks 12. The motor is configured to enable drone charging station 10 to rotate about a shaft, e.g., alignment element 52, where the drone charging station 10 rotates with respect to the drones 18. In one embodiment, the base blocks 12 of drone charging station 10 rotate with respect to the mounting blocks 30 situated at one or both ends of drone charging station 10, which serve to hold drone charging station 10 in place. Thus, as the drone charging station 10 rotates, the base blocks 12 also rotate but the mounting blocks 30 remain fixed. Thus, instead of the drones 18 rotating around a stationary cylinder of base blocks 12, the cylinder of blocks rotates with respect to stationary drones 18.

**[0071]** In this embodiment, in order to prevent drones 18 from rotating once drones 18 enter drone charging station 10, a rotation inhibitor 82, which could be in the form of a locking plate, is inserted within mounting aperture 26 to lock drones 18 at a predetermined angle or orientation. Rotation inhibitor 82 is configured to inhibit the rotation of drones 18 when they contact drone charging station 10, thereby allowing drones 18 to travel along drone guiding path 17 due to the rotation of drone charging station 10, rather than due to the rotation of the drones 18. When drone charging station 10 rotates, drones 18 move up or down drone guiding path 17 relative to drone charging station 10 because of the mechanical interaction between the drone threads and those on the drone charging station 10. Advantageously, this embodiment allows drones 18 to conserve energy when moving along drone charging station 10. Further, this embodiment may be beneficial for low-power drones 18 that may have trouble in providing enough torque to rotate along the drone charging station 10, and instead providing one or more motors of sufficient power and/or torque.

**[0072]** As shown in FIG. 16, multiple drones 18 are engaged with drone charging station 10. In this embodiment, each drone 18 has a rotation inhibitor 82 inserted within the drone's mounting aperture 26, to prevent each

drone from rotating. Instead, one or more motors are used to allow drone charging station 10 to rotate while each drone 18 is prevented from rotating. The effect is the same as if the drones 18 were rotating with respect to a stationary drone charging station 10, with the result being that drones 18 enter one end of drone charging station 10 and travel along drone guiding path 17 in the manner described above while being charged, until exiting drone charging station 10 at the opposite end from which they entered. The result is a drone charging station 10 that provides a first-in-first-out (FIFO) feature, which enables drones 18 that enter drone charging station 10 at one end to remain on drone charging station 10 till fully charged before exiting at an opposite end of drone charging station 10. Thus, the drones exit drone charging station 10 in the same order that they entered.

**[0073]** In another embodiment, drone charging station 10 provides a last-in-first-out (LIFO) feature, which enables the last drone 18 that enter drone charging station 10 at one end to remain on drone charging station 10 till adequately charged before exiting at the same end of drone charging station 10. Thus, that specific drone 18 could exit drone charging station 10 out of order, if required.

**[0074]** In one embodiment, rotation inhibitor 82 is in the form of a moveable lock plate, where the size and dimensions of the lock plate can vary based on the size of the drones 18. This can be used to accommodate smaller drones, where the lock plate can then return to a larger size for larger drones 18. In another embodiment, rotation inhibitor 82 could be in the form of bar instead of a lock plate, and configured to perform the same function as the lock plate.

**[0075]** In one embodiment, rotation inhibitor 82 is in the form of an expandable lock plate that can be transformed into various shapes, for example, into a T-shape at the end of the lock plate closest to the shaft of drone charging station 10 in order to "lock" those drones 18 to drone charging station 10 that do not have mounting aperture 26.

**[0076]** In one embodiment, rotation inhibitor 82 is in the form of a magnetic-enhanced lock plate. In this embodiment, the lock plate and mounting aperture 26 are fabricated from magnetic materials of opposite polarity to enhance the locking action. For example, referring to FIG. 16, if the magnetic material of rotation inhibitor 82 on a first side (for example, the left side when looking at the front cut-away view of FIG. 16) of drone charging station 10 is of a first polarity, then the corresponding first side (i.e., the left inner side of drone charging station 10 in FIG. 16) of the drone's mounting aperture 26 is of an opposite polarity. Similarly, if the magnetic material of rotation inhibitor 82 on a second side (for example, the right side when looking at the front cut-away view of FIG. 16) of drone charging station 10 is of a first polarity, then the corresponding second side (i.e., the right inner side of drone charging station 10 in FIG. 16) of the drone's mounting aperture 26 is of an opposite polarity.

**[0077]** In another embodiment, the rotation inhibitor 82 includes guiding indicia to assist in alignment of the rotation inhibitor 82 within mounting aperture 26. The guiding indicia could be any visual indicia, for example, a line, or a groove or recess parallel to the axis of the drone charging station 10 on one or both sides of the rotation inhibitor 82. In another embodiment, a corresponding wedge on the inner side of the drone's mounting aperture 26 could be implemented in order to fit into the recess of the rotation inhibitor 82.

**[0078]** In one embodiment, one or more step motors are utilized to rotate drone charging station 10. Although the present disclosure is not limited to the number or types of motors used to rotate drone charging station 10, stepper motors could be considered in order to have a predefined movement of the motor without requiring sensory equipment or utilizing reduced sensory equipment. The sensory equipment helps in the control of the rotation of drone charging station 10 and the movement of drones 18 in order to ensure proper alignment of the electrical contact points on drone charging station 10 and drones 18. With the use of stepper motors, or other similar precision devices, the sensory equipment could be reduced or removed entirely.

**[0079]** FIG. 17 illustrates another embodiment of the present disclosure, where instead of drones 18 engaging with drone charging station 10 via a drone guiding path 17 on the exterior of drone charging station 10, drones 18 enter a hollow charging tube 84 and engage with corresponding guiding paths along the interior of hollow charging tube 84. For simplicity, only a portion of hollow charging tube 84 is shown in FIG. 17, and only one drone 18 is shown as entering hollow charging tube 84. It is within the scope of the present disclosure for hollow charging tube 84 to be much longer, i.e., of sufficient length and circumference to receive multiple drones 18 at the same time.

**[0080]** In this embodiment, each drone 18 includes a stack of at least three elements at its edges in order to be able to enter hollow charging tube 84. These elements may include guiding regions to provide a guiding path or anchor for each drone 18 and also include electrical elements to provide the electrical connectivity to corresponding conductors in hollow charging tube 84.

**[0081]** Hollow charging tube 84 includes a plurality of interior conductor blocks along the interior of hollow charging tube 84, each of the plurality of interior conductor blocks sized to engage with and charge one or more drones 18 as the drones 18 travel within hollow charging tube 84. Hollow charging tube 84 includes a first interior conductor block 86 having a first polarity for electrically engaging with a corresponding first electrode 60 of drone 18, the first interior conductor block 86 having a first drone guiding portion 87. Hollow charging tube 84 includes second interior conductor block 88 having a second polarity different from the first polarity for electrically engaging with a corresponding second electrode 64 of drone 18, the second interior conductor block 88 having a second

drone guiding portion 89. Hollow charging tube 84 includes an interior insulator block 90 positioned between first conductor block 86 and second conductor block 88, the interior insulator block 90 having a third drone guiding portion 91 that engages with insulator 62. First drone guiding portion 87, second drone guiding portion 89 and third drone guiding portion 91 are arranged to provide a drone guiding path along an interior of hollow charging tube 84.

**[0082]** In one embodiment, first conductor 86 is located at a different relative height along drone 18 within hollow charging tube 84 as compared with second conductor 88. Thus, as each of the drones 18 travel down (or up) within hollow charging tube 84, the first electrode 60 of each drone 18 receives a charge from a corresponding first interior conductor block 86 situated at a first height within the interior of hollow charging tube 84 and the second electrode 64 of each drone 18 receives a charge from a corresponding second interior conductor block 88 situated at a second height within the interior of hollow charging tube 84. This continues as each drone 18 rotates within the interior of hollow charging tube 84, until each drone 18 has received sufficient charge, and exits an opposite end of hollow charging tube 84.

**[0083]** Thus, in this embodiment, one or more drones 18 are engaged within hollow charging tube 84 by entering inside a first end of hollow charging tube 84 and exiting an opposite end of hollow charging station after being charged. Guiding portions, i.e., first guiding portion 87, second guiding portion 89 and third drone guiding portion 91, which could be in the form of threads or protrusions such as pins, are situated on the inside of hollow charging tube 84. Corresponding guiding regions can also be placed on the peripheral portion of each drone 18, for example, on an outer edge of their blade protection area, and along electrodes 60 and 64 and insulator 62. The drones 18 perform a rotating action within hollow charging tube 84 in order to move from one instance of charging to the next instance of charging and finally out of the opposite end of hollow charging tube 84. In one embodiment, hollow charging tube 84 includes one or more apertures to allow for air to flow within hollow charging tube 84.

**[0084]** In another embodiment, a design similar to the embodiment depicted in FIGS. 1-16 and described above may be used, in order to provide a modular charging station. In one embodiment, a two-connection design is used where each individual charger along hollow charging tube 84 is composed of multiple similar blocks, for example, six, in which the first and the third blocks are made of a conductive material and the remaining blocks (second, fourth to sixth) are made of non-conductive, i.e., insulator material. All conducting blocks of each type of connection (for example all those connected to the higher voltage point of hollow charging tube 84) are connected by inserting alignment element 52 within alignment aperture 42 of alignment tab 40 outside hollow charging tube 84, as depicted in FIG. 17. Additional alignment el-

ements 52 bars can be used to make hollow charging tube 84 more rigid.

**[0085]** In another embodiment, drone charging station 10 includes a plurality of hollow charging tubes 84 resulting in a plurality of first interior conductor blocks 86, a plurality of second interior conductor blocks 88 and a plurality of interior insulator blocks 90. Similar to the embodiment depicted in FIGS. 1-16, drone charging station 10 an alignment element 52, as discussed above, configured to align each of the plurality of first interior conductor blocks 86, second interior conductor blocks 88 and interior insulator blocks 90 to form a cylinder. The drone charging station 10 of this embodiment, similar to the embodiment depicted in FIGS. 1-16, includes a first conductor coupler, the first conductor coupler electrically coupling each of the plurality of first interior conductor blocks 88 together, the first conductor coupler being electrically conductive, and a second conductor coupler, the second conductor coupler electrically coupling each of the plurality of second interior conductor blocks 90 together, the second conductor coupler being electrically conductive. Drone charging station 10 may also include an insulator coupler, the insulator coupler coupling each of the plurality of insulator blocks together.

**[0086]** In another embodiment, first interior conductor block 86, second interior conductor block 88 and interior insulator block 90 each include a first end having a first engagement element and a second end having a second engagement element, the first end opposite the second end, wherein the first engagement element is matable with the second engagement element of an adjacent block to prevent rotational misalignment.

**[0087]** In another embodiment, drone charging station 10 further includes at least one insulator layer, the at least one insulator layer comprising at least one interior insulator block 90, the at least one insulator layer positioned between a first hollow charging tube 84 and a second hollow charging tube 84.

**[0088]** In another embodiment, drone charging station includes at least one motor configured to enable the at least one hollow charging tube 84 to rotate; and a rotation inhibitor to inhibit rotation of at least one drone 18 when at least one drone 18 enters drone charging station 10, the at least one drone 18 traveling along the drone guiding path due to the rotation of the at least one hollow charging tube 84.

**[0089]** In another embodiment, a cap or cover can be placed or affixed to the either end or both ends of hollow charging tube 84 in order to protect hollow charging tube 84 and drones 18 from external elements such as rain or other weather or non-weather-related external impact.

**[0090]** In another embodiment, the inside of hollow charging tube 84 is capable of being accessed via an opening in one or both sides of hollow charging tube 84 for the purpose of maintenance to hollow charging tube 84 and/or the drones 18 inside.

**[0091]** In another embodiment, hollow charging tube 84 includes a short-range optical or RF sensor, or radar

equipment on one or both ends of hollow charging tube 84 in order to help in the navigation of drones 18 in their approach of hollow charging tube 84.

**[0092]** In another embodiment, an inverted half-cone can be placed or affixed to one or both ends of hollow charging tube 84 in order to assist in guiding the drones 18 into hollow charging tube 84.

**[0093]** FIG. 18 is a block diagram of a charging station controller 92 that may be used to allow drones 18 to use drone charging station 10. Charging station controller 92 may be located either on the drone 18 or it can be located and operated remotely, i.e., on the operator cloud dew, edge, or core.

**[0094]** In FIG. 18, the solid lines indicate signal connections and the hashed lines indicate power connections. Charging station controller 92 includes a processor 96, a memory or storage 98, and interconnection 100 which provides a communication interface between processor 96 and memory 98. Memory 98 may comprise any kind of volatile and/or non-volatile memory, e.g., cache and/or buffer memory and/or RAM (Random Access Memory) and/or ROM (Read-Only Memory) and/or optical memory and/or EPROM (Erasable Programmable Read-Only Memory). Processor 96 includes accelerators 102. Accelerators 102 can supply functions including but not limited to floating point unit (FPU) functions, graphics processing unit (GPU) functions, tensor processing unit (TPU) functions, or field-programmable gate array (FPGA) functions. Accelerators 102 may share the same silicon die with a main processor in system on chip (SoC) configurations.

**[0095]** Charging station software code 104, which is stored in memory 98 is configured to handle power transmission to the stack of base blocks 12 of drone charging station 10 and also configured to perform various drone-related tasks, such as, for example, approach, landing, and exiting, among others tasks. An Input/Output ("I/O") power component 106 enables charging station controller 92 to perform power processing before delivering power to drones 18 that have entered drone charging station 10. Processor 96 processes charging station software code 104 during operation of the power distribution and drone-related tasks.

**[0096]** The present disclosure describes a drone charging station 10 that can be used for simultaneous charging of multiple drones 18. In order for drones 18 to be able to use drone charging station 10, there may be protocols that need to be followed by drones 18 in order to avoid collision between drones 18 and for drone charging optimization. The protocols may vary depending on the type of drone 18 utilizing drone charging station 10.

#### Fully independent drones

**[0097]** In this embodiment, each drone 18 is arranged be able to navigate inside on its own. This can be done by utilization of sensors and cameras for positioning and navigation. Drone 18 must also be able to locate and

align itself with drone charging station 10 and proceed with enter/charge/stay/exit maneuvers. In this scenario, charging station controller 92 does not need to intervene with drone maneuvers. However, charging station controller 92 can observe and/or log the operations of the drones 18 and maintain the performance of drone charging station 10. Each drone 18 must also be able to locate other drones 18 which are approaching drone charging station 10 and avoid colliding with them with a simple protocol. When drone 18 enters drone charging station 10, it must move up (or down) to the highest (or lowest) available position. Drones 18 must move up (or down) according to the drone above (or below) them. If the drone's charge is complete and there are drones 18 below (or above) them, drone 18 must leave drone charging station 10 to make room for other drones 18 to be charged.

#### Collision avoidance protocol

**[0098]** If two or more drones 18 are approaching drone charging station 10, drones 18 only approach drone charging station 10 if there is no drone on its left (relative to the direction of the drone charging station 10). If there is a drone 18 on its left, drone 18 will maintain its position until the drone on its left completes its maneuver entering drone charging station 10.

#### Cloud (edge) Controller

**[0099]** In this embodiment, drones 18 do not have the internal capability to navigate and instead receive the navigation commands directly from a central charging station controller 92. The central charging station controller 92 uses positioning technology for locating drones 18 and drone charging station 10. Examples of positioning technology could be cameras, indoor positions systems, and short-range radar (i.e., time-of-flight camera, etc.), radio frequency ID (RFID), etc. The central charging station controller 92 then receives the battery-charge-information of drones 18, determines which drone 18 must enter drone charging station 10 first and sends the correct navigation commands to that particular drone 18. If it is determined that more than one drone 18 must charge at the same time, the central charging station controller 92 will calculate a delay period and will send each drone 18 to drone charging station 10 with a calculated delay in between.

#### Hybrid Controller

**[0100]** In this scenario, the drones 18 should obtain additional information from charging station controller 92 to land safely. In the hybrid controller scenario, drones 18 have some navigation capabilities of their own, however, they will receive some management information from charging station controller 92 as well. For example, each drone 18 has the ability to align itself with and enter



drone charging station 10 and move up (or down) and finally exit from drone charging station. However, the drone 18 must wait for some indication from charging station controller 92 that it is safe to proceed.

#### Hybrid drones' intelligence is on the cloud

**[0101]** Although in the hybrid scenario, some intelligence remains with drones 18, it is not necessary to mount a processor on drones 18. The drones 18 can be connected to a wireless communication network (e.g., Wi-Fi) in order to maintain an affordable and reliable connection with the charging station controller 92. Drones 18 can use the same wireless connection for sending all sensors data to the cloud (for example, at-the-edge or at-the-access in order to avoid unintended latency) and the data processing can be done on the cloud and the navigation commands can be produced and sent back to drone 18 for execution. In this fashion, manufacturing costs of the drones 18 will be significantly reduced. Furthermore, utilizing this approach, the capabilities of multiple drones 18 can be consolidated on a computing resource in the cloud by utilization of light weight container technologies, or any other virtualization technologies.

#### Hybrid at the community level

**[0102]** Although several embodiments of the present disclosure are designed for a household-oriented environment, where, for example, ownership is solely carried by the house or dwelling owner, it is possible to have a community-level scenario in which the multiple owners of drones 18 share a community station and its associated controller and logic.

#### Landed operation

**[0103]** In this embodiment, drones 18 can land on drone charging station 10 and perform some of their tasks, for example, surveillance, even if the drones 18 are fully charged. This helps to avoid unnecessary use of energy in the drone's batteries and also to reduce the noise/collision probabilities.

#### Queue of drones approaching the drone charging station

**[0104]** If several drones 18 need to be charged, the drones 18 to contact charging station controller 92 and then charging station controller 92 will sort all the requests based on different parameters such as amount of battery charge left for each drone 18 and their distance to drone charging station 10. The charging station controller 92 will then report back the sorted queue to each of the drones 18. The drones 18 can then form a queue on their approach drone charging station according to the sorted queue.

**[0105]** Referring now to FIG. 19, yet another embodiment of the present disclosure is shown. In the embodi-

ment of FIG. 19 the drone docking station 10 is provided without stacking base blocks 12. For example, in one embodiment, the drone docking station 10 may include an elongated docking shaft 120 formed as a unitary piece.

5 Accordingly, instead of forming the elongated docking shaft 120 with stackable base blocks 12 as described herein above with reference to FIG. 1, the elongated docking shaft 120 may be a one-piece body. The one-piece body may be formed by any known manufacturing methods (e.g., injection molding, etc.), which are well-known and therefore will not be discussed in great detail herein. Unlike the embodiments discussed above, docking shaft 120 need not have a conductive component. However, docking shaft 120 can be a unitary body that does include the conductive and insulating arrangement discussed above to allow drone 18 to charge in a manner discussed above. For example, the unitary body docking shaft 120 may, in some embodiments, have conductive coatings applied with are interconnected by polarity to facilitate charging. However, in embodiment discussed below relating to wireless charging, docking shaft 120 may be composed entirely of an insulating material such as plastic.

**[0106]** The elongated docking shaft 120 may be sized to engage with at least one drone 18, and, preferably multiple drones 18. The elongated docking shaft 120 may be of any height or length, but is preferably of a height or length sized to allow multiple drones 18 to be charged at the same time as the drones 18 travel along the docking shaft 120.

**[0107]** The elongated docking shaft 120 may be cylindrical in shape. In other embodiments, the elongated docking shaft 120 may be other shapes, such as, for example, conical as long as the drones 18 have a corresponding opening to allow the drones 18 to proceed along the charging path. In any case, the shape of the elongated docking shaft 120 should provide an elongated docking body sized to engage one or more drones 18 for charging according to the principles in the present disclosure.

**[0108]** The elongated docking shaft 120 may have a first end and a second end. The first end may be considered a drone entrance end 122 and the second end may be considered a drone exit end 124, opposite the drone entrance end 122. Drones 18 first interact with docking shaft 120 at drone entrance end 122 and complete the charging interaction at the drone exit end 124.

**[0109]** In one embodiment, docking shaft 120 may be configured to selectively couple with other docking shafts 120 in an end-to-end manner, in order to provide for a selectable height/length drone docking station 10. Yet, in such embodiments, each individual, elongated docking shaft 120 is preferably configured to engage with one or more drones 18 for charging the one or more drones 18 from one end of the elongated docking shaft 120 to the opposite end. In other words, the charging station 10 may charge multiple drones 18 with one elongated docking shaft 120, in some embodiments, or, may be configured to selectively couple with other elongated docking

shafts 120 if a higher or longer shaft 120 is desired in order to accommodate an even larger quantity of drones 18. In other embodiments, the charging station 10 may include a single elongated docking shaft 120 that is not couplable with other docking shafts 120.

**[0110]** The drone docking station 10 may further include a drone guiding thread 126. The drone guiding thread is discussed in detail herein above with reference to FIGS. 1-18, which discussion generally applies to the drone guiding thread 126 depicted in FIG. 19 in this embodiment. In FIG. 19, illustrating a unitary piece docking shaft 120, the drone guiding thread 126 may also be a unitary piece, drone guiding thread 126. The drone guiding thread 126 may be helically disposed along the elongated docking shaft 120. The drone guiding thread 126 is configured to engage with a corresponding guiding region 66, 68, and/or 67 (see FIG. 21) on the drone 18 to allow the drone 18 to move along the drone guiding thread 126 from the drone entrance end 122 toward the drone exit end 124. In one embodiment, the drone guiding thread 126 may extend from the drone entrance end 122 to the drone exit end 124. In other embodiments, the drone guiding thread 126 may extend substantially from the drone entrance end 122 to the drone exit end 124, but may terminate just short of one or both of the ends 122, 124.

**[0111]** In one embodiment, the drone guiding thread 126 may be formed along an exterior surface 128 of the elongated docking shaft 120, as depicted, for example, in FIG. 19. In another embodiment, the drone guiding thread 126 may be formed along an interior surface 130 of the elongated docking shaft 120 (see FIG. 20). Stated another way, the elongated docking shaft 120 may define an inner volume, with the drone guiding thread 126 disposed in the inner volume, as shown in FIG. 20, for example. In some embodiments, the charging station 10 may include the drone guiding thread 126 formed on both the exterior surface 128 and the interior surface 130.

**[0112]** Referring again primarily to FIG. 19, in one embodiment, the drone docking station 10 may include at least one electrical charging element 132. Drone docking station 10 may include a single electrical charging element 132, or may include multiple electrical charging elements 132 disposed along at least a part of the elongated docking shaft 120. In one embodiment, the electrical charging element 132 is disposed to charge the drone 18 as the drone 18 moves along the drone guiding thread 126. In other embodiments, the electrical charging element 132 of the drone docking station 10 may be disposed to charge the drone 18 as the drone 18 engages with the docking station 10, such as, for example, being parked at the docking station 10, or initially docking at the docking station 10 at, for example, the drone entrance end 122. In yet other embodiments, the electrical charging element 132 of the docking station 10 may be disposed to charge the drone 18 before the drone 18 physically contacts the docking station 10, such as, for example, being in proximity to the docking station 10, with a

range of, for example, a wireless charging signal.

**[0113]** Electrical charging element 132 may be an electrical charging transmitting element for transmitting a wireless charging signal to the drone 18 for charging the drone 18 when the drone 18 is within a range of the wireless charging signal. The range of the wireless charging signal may vary according to known wireless charging parameters, such as, for example, a strength of the signal. In one embodiment, the electrical charging element 132 is configured to transmit a wireless charging signal to the drone 18 for charging the drone 18 as drone 18 moves along drone guiding thread 126. In other embodiments, the electrical charging element 132 is configured to transmit a wireless charging signal to the drone 18 for charging the drone 18 before the drone 18 physically contacts the docking station 10, but is within a proximity to the docking station 10 corresponding to the range of the wireless charging signal. In one embodiment, electrical charging element 132 is an inductive charging antenna. In another embodiment, electrical charging element 132 is a resonance charging antenna. In yet other embodiments, the electrical charging element 132 is another type of wireless charging element. In other words, embodiments are not limited to a particular type of wireless charging technology. Also, the actual wireless charging circuits are beyond the scope of this disclosure and are not discussed herein. It is contemplated that circuits and arrangements for wireless charging are well known.

**[0114]** In an alternative embodiment, electrical charging element 132 includes one or more electrodes for contact charging. Stated another way, electrical charging element 132 may include an electrically conductive surface (e.g., a metallic surface) for contact charging the drone 18 as the drone 18 moves along the drone guiding thread 126. In one embodiment, the electrical charging element 132 may be formed as part of drone guiding thread 126. In some embodiments, the drone docking shaft 120 may include multiple electrical charging elements 132, each being disposed along the elongated docking shaft 120 and/or along drone guiding thread 126. In one embodiment, at least a portion of electrical charging element 132 may be embedded within elongated docking shaft 120. In some embodiments, electrical charging element 132 may be formed as a charging pad embedded in the sidewall of elongated docking shaft 120. Referring now briefly again to FIG. 20, in one embodiment, the electrical charging element 132 may be disposed in the inner volume defined by elongated docking shaft 120.

**[0115]** Referring now to FIG. 21, a partial view of receiving region 28 of center portion 20 of drone 18 is shown in an alternative embodiment. Receiving region 28 and center portion 20 of drone 18 being depicted in FIG. 21 are substantially similar to the corresponding elements described with reference to FIG. 10. FIG. 21 depicts an alternative embodiment in which center portion 20 includes an electrical charge receiving element 134 configured to receive a wireless charging signal (as opposed to the electrode 60, 64 and insulator regions 62 shown

in FIG. 10). In an embodiment in which the drone docking station 10 includes wireless charging elements 132, the corresponding drones 18 may be configured to include one or more wireless charge receiving elements 134. Stated another way, electrical charge receiving element 134 may be disposed to wirelessly engage electrical charging transmitting element 132 of drone docking station 10. Drone 18 may include a single electrical charge receiving element 134 in some embodiments, and may, in other embodiments, include multiple electrical charge receiving elements 134.

**[0116]** In one embodiment, electrical charge receiving element 134 may be formed as an inductive charge receiving antenna. In another embodiment, electrical charge receiving element 134 may be formed as a resonance charge receiving antenna. In yet other embodiments, the electrical charge receiving element 134 may be formed as other non-contact wireless charge receiving elements.

**[0117]** In one embodiment, electrical charge receiving element 134 may be disposed adjacent to one or more of the guiding regions 66, 67, and 68 of drone 18. In some embodiments, electrical charge receiving element 134 may be embedded in a sidewall corresponding to the center portion 20. In some embodiments, electrical charge receiving element 134 may be disposed to receive a wireless charging signal from an electrical charging transmitting element 132 disposed in the inner volume of elongated docking shaft 120. In yet another embodiment, electrical charge receiving element 134 of drone 18 may be formed as other types of charge receiving elements, such as, for example, an electrically conductive surface configured to receive a contact charge from the drone docking station 10.

**[0118]** Referring now to FIGS. 22 and 23, yet another alternative embodiment of a drone docking station 10 and a portion of a drone 18 is illustrated, respectively. The drone docking station 10 depicted in FIG. 22 illustrates an elongated docking shaft 120 having an alternative thread arrangement. Specifically, the elongated docking shaft 120 shows the drone guiding portion 126 sized to matingly engage corresponding protruding guiding regions 136, 137, 138 on center portion 20.

**[0119]** It should be understood that many different types and forms of thread arrangements may be provided on drone docking station 10 and drone 18 to allow drone 18 to engage with the drone docking station 10 so as to move along docking shaft 120 for charging one or more drones 18.

**[0120]** In addition, it should be understood that many different types of docking shafts may be provided in embodiments of the present disclosure, some embodiments being formed by stackable blocks, and other embodiments, being formed as a unitary piece docking shaft, according to the principles of the present disclosure. Further, many different charging configurations are within the scope of various embodiments of the present disclosure, including without limitation contact charging con-

figurations (e.g., electrodes and conductive surfaces) as well as wireless charging configurations.

**[0121]** The present disclosure provides, in multiple embodiments, a drone charging station 10 configured to charge at least one drone 18. The drone charging station 10 includes at least one charging stack 15 comprised of a plurality of base blocks 12, each of the plurality of base blocks 12 sized to engage with the at least one drone 10. The at least one charging stack 15 includes a first conductor block 12a having a first polarity for electrically engaging with a corresponding first electrode 60 of the at least one drone 18, the first conductor block 12a having a first drone guiding portion 46; a second conductor block 12b having a second polarity different from the first polarity for electrically engaging with a corresponding second electrode 64 of the at least one drone 18, the second conductor block 12b having a second drone guiding portion 48; and an insulator block 12c positioned between the first conductor block 12a and the second conductor block 12b, the insulator block 12c having a third drone guiding portion 50. The first drone guiding portion 46, the second drone guiding portion 48 and the third drone guiding portion 50 being arranged to provide a drone guiding path 17 along the at least one charging stack 10.

**[0122]** In one embodiment of drone charging station 10 the first drone guiding portion 46 comprises a first thread, the second drone guiding portion 48 comprises a second thread, and the third drone guiding portion 50 comprises a third thread, and wherein the drone guiding path 17 comprises a continuous drone guiding thread formed by an arrangement of the first thread, the second thread and the third thread.

**[0123]** In one embodiment, the arrangement includes a starting point of the third thread being positioned proximate an ending point of the first thread and a starting point of the second thread being positioned proximate an ending point of the third thread.

**[0124]** In one embodiment, the first drone guiding portion 46 comprises a first plurality of pins, the second drone guiding portion 48 comprises a second plurality of pins, and the third drone guiding portion 50 comprises a third plurality of pins, and wherein the drone guiding path 17 is formed by an arrangement of the first plurality of pins, the second plurality of pins and the third plurality of pins.

**[0125]** In one embodiment, the drone charging station 10 is configured to charge a plurality of drones 18 at the same time.

**[0126]** In one embodiment, drone charging station 10 further includes an accessory block 78 having an end affixed to an end of one of the at least one charging stack 15, the accessory block 78 being tapered toward the end opposite the end affixed to the end of one of the at least one charging stack 15.

**[0127]** In one embodiment, the drone charging station 10 further includes a plurality of charging stacks 15 resulting in a plurality of first conductor blocks 12a, a plurality of second conductor blocks 12b and a plurality of insulator blocks 12c. The drone charging station 10 fur-

ther includes an alignment element 52 configured to align each of the plurality of first conductor blocks 12a, second conductor blocks 12b and insulator blocks 12c to form a cylinder, a first conductor coupler 54, the first conductor coupler 54 electrically coupling each of the plurality of first conductor blocks 12a together, the first conductor coupler 54 being electrically conductive, and a second conductor coupler 56, the second conductor coupler 56 electrically coupling each of the plurality of second conductor blocks 12b together, the second conductor coupler 56 being electrically conductive.

**[0128]** In one embodiment, the drone charging station 10 further includes an insulator coupler 58, the insulator coupler 58 coupling each of the plurality of the insulator blocks 12c together.

**[0129]** In one embodiment, each of the plurality of first conductor blocks 12a, second conductor blocks 12b, and insulator blocks 12c include an alignment tab 40 extending within an interior of the cylinder, the alignment tab 40 including at least an alignment aperture 42 sized to receive the alignment element 52.

**[0130]** In one embodiment, each of the plurality of blocks 12 comprises a first end having a first engagement element and a second end having a second engagement element, the first end opposite the second end, wherein the first engagement element is matable with the second engagement element of an adjacent block 12 to prevent rotational misalignment.

**[0131]** In one embodiment, the drone guiding path 17 is formed along an exterior of the at least one charging stack 15.

**[0132]** In one embodiment, the drone charging station 10 further includes at least one insulator stack 12c, the at least one insulator stack comprising at least one insulator block 12c, the at least one insulator stack positioned between one of the at least one charging stack 15 and a second charging stack 15.

**[0133]** In one embodiment, the drone charging station further includes at least one motor configured to enable the at least one charging stack 15 to rotate and a rotation inhibitor 82 to inhibit rotation of the at least one drone 18 when the at least one drone 18 contacts the drone charging station 10, the at least one drone 10 traveling along the drone guiding path 17 due to the rotation of the at least one charging stack 15.

**[0134]** In one embodiment, the insulator block 12c comprises a plurality of separate insulator members.

**[0135]** In one embodiment, the drone charging station 10 further includes a third conductor block for electrically engaging with a corresponding electrode of the at least one drone 18, and a second insulator block positioned between one of the first conductor block 12a and the third conductor block and the second conductor block 12b and the third conductor block, third conductor block configured to provide data transmission to the at least one drone 18.

**[0136]** The present disclosure also provides, in one embodiment, a drone charging station 10 configured to

charge at least one drone 18. The charging station 10 including at least one hollow charging tube 84 comprised of a plurality of interior blocks, each of the plurality of interior blocks sized to engage with the at least one drone 18. The at least one hollow charging tube 84 includes a first interior conductor block 86 having a first polarity for electrically engaging with a corresponding first electrode 60 of the at least one drone 18, the first interior conductor block 86 having a first drone guiding portion 87, a second interior conductor block 88 having a second polarity different from the first polarity for electrically engaging with a corresponding second electrode 64 of the at least one drone 18, the second interior conductor block 88 having a second drone guiding portion 89, and an interior insulator block 90 positioned between the first interior conductor block 86 and the second interior conductor block 88, the interior insulator block 90 having a third drone guiding portion 91. The first drone guiding portion 87, the second drone guiding portion 89 and the third drone guiding portion 91 being arranged to provide a drone guiding path along an interior of the at least one hollow charging tube.

**[0137]** In one embodiment, the first drone guiding portion 87 comprises a first thread, the second drone guiding portion 89 comprises a second thread, and the third drone guiding portion 91 comprises a third thread, and wherein the drone guiding path comprises a continuous drone guiding thread formed by an arrangement of the first thread, the second thread and the third thread.

**[0138]** In one embodiment, the arrangement includes a starting point of the third thread being positioned proximate an ending point of the first thread and a starting point of the second thread being positioned proximate an ending point of the third thread.

**[0139]** In one embodiment, the first drone guiding portion 87 comprises a first plurality of pins, the second drone guiding portion 89 comprises a second plurality of pins, and the third drone guiding portion 91 comprises a third plurality of pins, and wherein the drone guiding path is formed by an arrangement of the first plurality of pins, the second plurality of pins and the third plurality of pins.

**[0140]** In one embodiment, the drone charging station 10 is configured to charge a plurality of drones 18 at the same time.

**[0141]** In one embodiment, the drone charging station 10 further includes an accessory block 78 having an end affixed to an end of one of the at least one hollow charging tube 84, the accessory block 78 being tapered toward the end opposite the end affixed to the end of one of the at least hollow charging tube 84.

**[0142]** In one embodiment, the drone charging station 10 further includes a plurality of hollow charging tubes 84 resulting in a plurality of first interior conductor blocks 86, a plurality of second interior conductor blocks 88 and a plurality of interior insulator blocks 90. The drone charging station 10 further includes an alignment element 52 configured to align each of the plurality of first interior conductor blocks 86, second interior conductor blocks

88 and interior insulator blocks 90 to form a cylinder, a first conductor coupler, the first conductor coupler electrically coupling each of the plurality of first interior conductor blocks 88 together, the first conductor coupler being electrically conductive, and a second conductor coupler, the second conductor coupler electrically coupling each of the plurality of second interior conductor blocks 90 together, the second conductor coupler being electrically conductive.

**[0143]** In one embodiment, the drone charging station 10 further includes an insulator coupler, the insulator coupler coupling each of the plurality of interior insulator blocks 90 together.

**[0144]** In one embodiment, each of the plurality of first interior conductor blocks 88, second interior conductor blocks 90, and interior insulator blocks 90 include an alignment tab 40 extending outside of the cylinder, the alignment tab 40 including an aperture 42 sized to receive the alignment element 52.

**[0145]** In one embodiment, each of the plurality of blocks 86, 88, 90, comprises a first end having a first engagement element and a second end having a second engagement element, the first end opposite the second end, wherein the first engagement element is matable with the second engagement element of an adjacent block to prevent rotational misalignment.

**[0146]** In one embodiment, drone charging station 10 further includes at least one insulator layer, the at least one insulator layer comprising at least one insulator block, the at least one insulator layer positioned between one of the at least one charging hollow tube 84 and a second hollow charging tube 84.

**[0147]** In one embodiment, drone charging station 10 further includes at least one motor configured to enable the at least one hollow charging tube 84 to rotate, and a rotation inhibitor 82 to inhibit rotation of the at least one drone 18 when the at least one drone 18 enters the drone charging station 10, the at least one drone 18 traveling along the drone guiding path due to the rotation of the at least one hollow charging tube 84.

**[0148]** In another embodiment, a system for charging at least one drone 18 is provided. The system includes at least one drone 18, each of the at least one drone 18 including a first electrode 60 for electrically engaging with a corresponding first conductor block 12a in the drone charging station 10, the first electrode 60 including a first guiding region 66, a second electrode 64 for electrically engaging with a corresponding second conductor block 12b in the drone charging station 10, the second electrode 64 including a second guiding region 68, and an insulator 62, the insulator 62 including a third guiding region 67. The system further includes a guiding system comprising at least a portion of the first guiding region 66, the second guiding region 68, and the third guiding region 67, the guiding system configured to engage a corresponding guiding region of the drone charging station in order provide a drone guiding path 17 along the drone charging station 10.

**[0149]** In one embodiment, the first guiding region 66, the second guiding region 68, and the third guiding region 67 are recesses, each of the recesses configured to engage a corresponding thread of the drone charging station 10.

**[0150]** In one embodiment, the drone guiding path 17 is along an exterior of the drone charging station 10.

**[0151]** In one embodiment, each of the at least one drone 18 further includes a mounting aperture 28 configured to allow the at least one drone 18 to travel past a mounting arm 32 that affixes the drone charging station 10 to a surface.

**[0152]** In one embodiment, the at least one drone 18 includes a receiving region 28 sized to receive an outer perimeter of the drone charging station 10.

**[0153]** In one embodiment, the first guiding region 66, the second guiding region 68, and the third guiding region 67 are disposed within at least a portion of the receiving region 28.

**[0154]** In one embodiment, each of the at least one drone 18 is sized to fit within an interior of the drone charging station 10, and wherein the first electrode 60, the second electrode 64, and the insulator portion 62 are each disposed along an exterior region of the at least one drone 18, the drone guiding path 17 being formed along an interior surface of the drone charging station 10.

**[0155]** In another embodiment, a drone docking station configured to receive at least one drone is provided. The docking station includes a docking shaft sized to engage with the at least one drone 18, the docking shaft having a drone entrance end and a drone exit end opposite the drone entrance end, and a drone guiding thread helically encircling an exterior portion of the elongated docking shaft, the drone guiding thread configured to engage with a corresponding guiding region on the at least one drone 18 to allow the at least drone to move along the drone guiding thread from the drone entrance end to the drone exit end.

**[0156]** According to yet another aspect, a drone docking station 10 configured to receive at least one drone 18 includes an elongated docking shaft 120 sized to engage with the at least one drone 18, the docking shaft 120 having a drone entrance end 122 and a drone exit end 124 opposite the drone entrance end 122; and a drone guiding thread 126 helically disposed along the elongated docking shaft 120, the drone guiding thread 126 configured to engage with a corresponding guiding region on the at least one drone 18 to allow the at least drone 18 to move along the drone guiding thread 126 from the drone entrance end 122 to the drone exit end 124.

**[0157]** According to this aspect, in some embodiments, the elongated docking shaft 120 is formed as a unitary piece. In some embodiments, the drone docking station 10 further includes at least one electrical charging transmitting element 132 for transmitting a wireless charging signal to the at least one drone 18 for charging the at least one drone 18 when the at least one drone (18) is

within a range of the wireless charging signal. In some embodiments, the elongated docking shaft 120 has an inner volume, and the at least one electrical charging element 132 is disposed in the inner volume. In some embodiments, the at least one electrical charging transmitting element 132 is formed as part of the drone guiding thread 126. In some embodiments, the at least one electrical charging transmitting element 132 is an inductive charging antenna. In some embodiments, the at least one electrical charging transmitting element 132 is a resonance charging antenna. In some embodiments, the drone docking shaft 120 has an exterior surface 128, the drone guiding thread 126 being formed along the exterior surface 128. In some embodiments, the drone guiding thread 126 extends from the drone entrance end 122 to the drone exit end 124. In some embodiments, the drone docking station 10 further includes at least one motor configured to enable the elongated docking shaft 120 to rotate for moving the at least one drone 18 along the at least one drone guiding thread 126. In some embodiments, the drone docking station 10 further includes at least one electrically conductive surface for contact charging the at least one drone 18 as the drone moves along the drone guiding thread.

**[0158]** According to another aspect of the disclosure, a system for charging at least one drone 18 includes a docking station 10 and at least one drone 18. In this aspect, the docking station 10 includes an elongated docking shaft 120 sized to engage with the at least one drone 18, the docking shaft 120 having a drone entrance end 122 and a drone exit end 124 opposite the drone entrance end 122; and a drone guiding thread 126 helically disposed along the elongated docking shaft 120, the drone guiding thread 126 configured to engage with a corresponding guiding region on the at least one drone 18 to allow the at least drone 18 to move along the drone guiding thread 126 from the drone entrance end 122 to the drone exit end 124. In this aspect, each of the at least one drones 18 includes a guiding region, the guiding region arranged to engage a corresponding portion of the drone guiding thread 126 to allow the at least one drone 18 to travel along the drone guiding thread 126 from the drone entrance end 122 to the drone exit end 124.

**[0159]** According to this aspect, in some embodiments, the elongated docking shaft 120 is formed as a unitary piece. In some embodiments, the docking station 10 further includes at least one electrical charging transmitting element 132 for transmitting a wireless charging signal to the at least one drone 18 for charging the at least one drone 18 when the at least one drone 18 is within a range of the wireless charging signal; and each of the at least one drones 18 includes an electrical charge receiving element 134 for receiving the wireless charging signal. In some embodiments, the electrical charge receiving element 134 is disposed adjacent the guiding region. In some embodiments, the at least one electrical charge receiving element 134 of the at least one drone 18 is disposed to wirelessly engage the at least one electrical

charging transmitting element 132 of the drone docking station 10, the at least one electrical charging transmitting element 132 of the drone docking station 10 being disposed in an inner volume of the elongated docking shaft 120. In some embodiments, each of the at least one drone 18 defines a receiving region 28 sized to receive an outer perimeter of the drone charging station 10 such that the at least one guiding region engages the drone guiding thread 126 disposed along the exterior surface 128 of the drone docking shaft 120. In some embodiments, the at least one electrical charge receiving element 134 of the at least one drone 18 is an inductive charging antenna. In some embodiments, the at least one electrical charge receiving element 134 of the at least one drone is a resonance charging antenna. In some embodiments, each of the at least one drones 18 defines a receiving region 28 sized to receive an outer perimeter of the drone charging station 10 such that the at least one guiding region engages the drone guiding thread 126 formed along an exterior surface 128 of the drone docking shaft 120. In some embodiments, the guiding system is configured to move the at least one drone 18 along the drone guiding thread 126 by at least one motor configured to rotate the elongated docking shaft 120. In some embodiments, the docking station 10 further comprises at least one electrically conductive surface disposed to contact charge at least one electrode 60 disposed on the at least one drone 18 as the drone 18 moves along the drone guiding thread 126.

**[0160]** According to another aspect, a drone docking station 10 configured to receive at least one drone 18 includes a docking shaft 120 sized to engage with the at least one drone 18, the docking shaft 120 having a drone entrance end 122 and a drone exit end 124 opposite the drone entrance end 122; at least one drone guiding portion 126 helically encircling an exterior portion of the docking shaft 120, the at least one drone guiding portion 126 configured to engage with a corresponding at least one guiding portion on the at least one drone 18 to allow the at least one drone 18 to move along the at least one drone guiding portion 126 of the docking shaft 120 from the drone entrance end 122 to the drone exit end 124; and at least one electrical charging transmitting element 132 for transmitting a wireless charging signal to the at least one drone 18 for charging the at least one drone 18 when the at least one drone 18 is within a range of the wireless charging signal.

**[0161]** According to this aspect, in some embodiments, the drone guiding portion 126 of the docking shaft 120 is formed as a thread. In some embodiments, the drone guiding portion 126 of the docking shaft 120 is formed by protrusions. In some embodiments, the drone docking station 10 further includes at least one motor configured to enable the docking shaft 120 to rotate for moving the at least one drone 18 along the at least one drone guiding portion 126.

**[0162]** As will be appreciated by one of skill in the art, some of the concepts described herein may be embodied

as a method, data processing system, and/or computer program product. Accordingly, the concepts described herein may take the form of an entirely hardware embodiment, an entirely software embodiment or an embodiment combining software and hardware aspects all generally referred to herein as a "circuit" or "module." Furthermore, the disclosure may take the form of a computer program product on a tangible computer usable storage medium having computer program code embodied in the medium that can be executed by a computer. Any suitable tangible computer readable medium may be utilized including hard disks, CD-ROMs, electronic storage devices, optical storage devices, or magnetic storage devices.

**[0163]** Some embodiments are described herein with reference to block diagrams of methods, systems and computer program products. It will be understood that each block in the block diagrams, and combinations of blocks in the block diagrams, can be implemented by computer program instructions. These computer program instructions may be provided to a processor of a general purpose computer, special purpose computer, or other programmable data processing apparatus to produce a machine, such that the instructions, which execute via the processor of the computer or other programmable data processing apparatus, create means for implementing the functions/acts specified in the block diagram block or blocks.

**[0164]** These computer program instructions may also be stored in a computer readable memory or storage medium that can direct a computer or other programmable data processing apparatus to function in a particular manner, such that the instructions stored in the computer readable memory produce an article of manufacture including instruction means which implement the function/act specified in the block diagram block or blocks.

**[0165]** The computer program instructions may also be loaded onto a computer or other programmable data processing apparatus to cause a series of operational steps to be performed on the computer or other programmable apparatus to produce a computer implemented process such that the instructions which execute on the computer or other programmable apparatus provide steps for implementing the functions/acts specified in the block diagram block or blocks. It is to be understood that the functions/acts noted in the blocks may occur out of the order noted in the operational illustrations. For example, two blocks shown in succession may in fact be executed substantially concurrently or the blocks may sometimes be executed in the reverse order, depending upon the functionality/acts involved. Although some of the diagrams include arrows on communication paths to show a primary direction of communication, it is to be understood that communication may occur in the opposite direction to the depicted arrows.

**[0166]** Computer program code for carrying out operations of the concepts described herein may be written in an object oriented programming language such as

Java® or C++. However, the computer program code for carrying out operations of the disclosure may also be written in conventional procedural programming languages, such as the "C" programming language. The program code may execute entirely on the user's computer, partly on the user's computer, as a stand-alone software package, partly on the user's computer and partly on a remote computer or entirely on the remote computer. In the latter scenario, the remote computer may be connected to the user's computer through a local area network (LAN) or a wide area network (WAN), or the connection may be made to an external computer (for example, through the Internet using an Internet Service Provider).

**[0167]** Many different embodiments have been disclosed herein, in connection with the above description and the drawings. It will be understood that it would be unduly repetitious and obfuscating to literally describe and illustrate every combination and subcombination of these embodiments. Accordingly, all embodiments can be combined in any way and/or combination, and the present specification, including the drawings, shall be construed to constitute a complete written description of all combinations and subcombinations of the embodiments described herein, and of the manner and process of making and using them, and shall support claims to any such combination or subcombination.

**[0168]** It will be appreciated by persons skilled in the art that the embodiments described herein are not limited to what has been particularly shown and described herein above. In addition, unless mention was made above to the contrary, it should be noted that all of the accompanying drawings are not to scale. A variety of modifications and variations are possible in light of the above teachings without departing from the scope of the following claims.

**Claims**

1. A drone docking station (10) configured to receive at least one drone (18), the docking station (10) comprising:
  - a docking shaft (120) sized to engage with the at least one drone (18), the docking shaft (120) having a drone entrance end (122) and a drone exit end (124) opposite the drone entrance end (122); and
  - a drone guiding portion (126) helically disposed along the docking shaft (120), the drone guiding portion (126) configured to engage with a corresponding guiding region on the at least one drone (18) to allow the at least drone (18) to move along the drone guiding portion (126) from the drone entrance end (122) to the drone exit end (124).
2. The drone docking station (10) of Claim 1, wherein

- the docking shaft (120) is formed as a unitary piece.
3. The drone docking station (10) according to any of Claims 1 or 2, wherein the docking shaft (120) is elongated. 5
  4. The drone docking station (10) according to any of Claims 1-3, wherein the drone guiding portion (126) of the docking shaft (120) is formed as a thread. 10
  5. The drone docking station (10) according to any of Claims 1-3, wherein the drone guiding portion of the docking shaft (120) is formed by protrusions. 15
  6. The drone docking station (10) of any of Claims 1-5, further comprising: 20
    - at least one electrical charging transmitting element (132) for transmitting a wireless charging signal to the at least one drone (18) for charging the at least one drone (18) when the at least one drone (18) is within a range of the wireless charging signal; 25
    - wherein, optionally, the docking shaft (120) has an inner volume, and the at least one electrical transmitting element (132) is disposed in the inner volume; and/or 30
    - wherein, optionally, the at least one electrical charging transmitting element (132) is formed as part of the drone guiding portion (126); and/or 35
    - wherein, optionally, the at least one electrical charging transmitting element (132) is an inductive charging antenna or wherein the at least one electrical charging transmitting element (132) is a resonance charging antenna. 40
  7. The drone docking station (10) of any of Claims 1-6, wherein the drone docking shaft (120) has an exterior surface (128), the drone guiding portion (126) being formed along the exterior surface (128); and/or 45
    - wherein the drone guiding portion (126) extends from the drone entrance end (122) to the drone exit end (124); and/or 50
    - further comprising at least one motor configured to enable the docking shaft (120) to rotate for moving the at least one drone (18) along the at least one drone guiding portion (126). 55
  8. The drone docking station (10) according to any of Claims 1-5 or 7 when not depending on claim 6, further comprising at least one electrically conductive surface for contact charging the at least one drone (18) as the drone (18) moves along the drone guiding portion (126).
  9. A system for charging at least one drone (18), the system comprising:
    - the drone docking station (10) according to any of Claims 1-5; and
    - at least one drone (18), each of the at least one drones (18) comprising:
      - a guiding region, the guiding region arranged to engage a corresponding portion of the drone guiding portion (126) to allow the at least one drone (18) to travel along the drone guiding portion (126) from the drone entrance end (122) to the drone exit end (124).
  10. The system of Claim 9, wherein the docking station (10) further comprises at least one electrical charging transmitting element (132) for transmitting a wireless charging signal to the at least one drone (18) for charging the at least one drone (18) when the at least one drone (18) is within a range of the wireless charging signal; and 5
    - each of the at least one drones (18) includes an electrical charge receiving element (134) for receiving the wireless charging signal; 10
    - wherein, optionally, the electrical charge receiving element (134) is disposed adjacent the guiding region; and/or 15
    - wherein, optionally, the at least one electrical charge receiving element (134) of the at least one drone (18) is disposed to wirelessly engage the at least one electrical charging transmitting element (132) of the drone docking station (10), the at least one electrical charging transmitting element (132) of the drone docking station (10) being disposed in an inner volume of the docking shaft (120). 20
  11. The system of any of Claims 9 and 10, wherein each of the at least one drone (18) defines a receiving region sized to receive an outer perimeter of the drone charging station (10) such that the at least one guiding region engages the drone guiding portion (126) disposed along the exterior surface (128) of the drone docking shaft (120). 25
  12. The system of any of Claims 10 and 11 when depending on claim 10, wherein the at least one electrical charge receiving element (134) of the at least one drone (18) is an inductive charging antenna; or wherein the at least one electrical charge receiving element (134) of the at least one drone (18) is a resonance charging antenna. 30
  13. The system of Claim 9, wherein each of the at least one drones (18) defines a receiving region sized to receive an outer perimeter of the drone charging station (10) such that the at least one guiding region engages the drone guiding portion (126) formed along an exterior surface (128) of the drone docking shaft (120). 35
  14. The system of any of Claims 9-13, wherein the guid-



ing system is configured to move the at least one drone (18) along the drone guiding portion (126) by at least one motor configured to rotate the docking shaft (120).

15. The system of Claim 9, wherein the docking station (10) further comprises at least one electrically conductive surface disposed to contact charge at least one electrode of the at least one drone (18) as the drone (18) moves along the drone guiding portion (126).

### Patentansprüche

1. Dockingstation (10) für Drohnen, die zum Aufnehmen mindestens einer Drohne (18) ausgelegt ist, wobei die Dockingstation (10) umfasst:

eine Andockwelle (120), die zum Eingreifen in die mindestens eine Drohne (18) bemessen ist, wobei die Andockwelle (120) ein Drohneneintrittsende (122) und ein Drohnenaustrittsende (124) gegenüber dem Drohneneintrittsende (122) umfasst; und  
einen Drohnenführungsabschnitt (126), der schraubenförmig entlang der Andockwelle (120) angeordnet ist, wobei der Drohnenführungsabschnitt (126) so ausgelegt ist, dass er in eine entsprechende Führungsregion auf der mindestens einen Drohne (18) eingreift, um zu ermöglichen, dass die mindestens eine Drohne (18) sich entlang des Drohnenführungsabschnitts (126) vom Drohneneintrittsende (122) zum Drohnenaustrittsende (124) bewegt.

2. Dockingstation (10) für Drohnen nach Anspruch 1, wobei die Andockwelle (120) als einstückiges Teil ausgebildet ist.

3. Dockingstation (10) für Drohnen nach Anspruch 1 oder 2, wobei die Andockwelle (120) länglich ist.

4. Dockingstation (10) für Drohnen nach einem der Ansprüche 1 bis 3, wobei der Drohnenführungsabschnitt (126) der Andockwelle (120) als ein Gewinde ausgebildet ist.

5. Dockingstation (10) für Drohnen nach einem der Ansprüche 1 bis 3, wobei der Drohnenführungsabschnitt der Andockwelle (120) durch Vorsprünge ausgebildet ist.

6. Dockingstation (10) für Drohnen nach einem der Ansprüche 1 bis 5, ferner umfassend:

mindestens ein Elektroaufladungs-Sendeelement (132) zum Senden eines Drahtlos-Ladesi-

gnals an die mindestens eine Drohne (18) zum Aufladen der mindestens einen Drohne (18), wenn die mindestens eine Drohne (18) innerhalb einer Reichweite des Drahtlos-Ladesignals ist;

wobei optional die Andockwelle (120) ein Innenvolumen aufweist, und das mindestens eine Elektroaufladungs-Sendeelement (132) im Innenvolumen angeordnet ist; und/oder  
wobei optional das mindestens eine Elektroaufladungs-Sendeelement (132) als Teil des Drohnenführungsabschnitts (126) ausgebildet ist; und/oder

wobei optional das mindestens eine Elektroaufladungs-Sendeelement (132) eine Induktionsaufladungsantenne ist, oder wobei das mindestens eine Elektroaufladungs-Sendeelement (132) eine Resonanzauf Ladungsantenne ist.

7. Dockingstation (10) für Drohnen nach einem der Ansprüche 1 bis 6, wobei die Drohnen-Andockwelle (120) eine Außenfläche (128) aufweist, wobei der Drohnenführungsabschnitt (126) entlang der Außenfläche (128) ausgebildet ist; und/oder  
wobei der Drohnenführungsabschnitt (126) sich vom Drohneneintrittsende (122) zum Drohnenaustrittsende (124) erstreckt; und/oder  
ferner umfassend mindestens einen Motor, der ausgelegt ist, um Drehung der Andockwelle (120) zum Bewegen der mindestens einen Drohne (18) entlang des mindestens einen Drohnenführungsabschnitts (126) zu ermöglichen.

8. Dockingstation (10) für Drohnen nach einem der Ansprüche 1 bis 5 oder 7, wenn nicht von Anspruch 6 abhängig, ferner umfassend eine elektrisch leitende Oberfläche zur Kontaktaufladung der mindestens einen Drohne (18), wenn die Drohne (18) sich entlang des Drohnenführungsabschnitts (126) bewegt.

9. System zum Aufladen mindestens einer Drohne (18), wobei das System umfasst:

eine Dockingstation (10) für Drohnen nach einem der Ansprüche 1 bis 5; und  
mindestens eine Drohne (18), wobei jede der mindestens einen Drohne (18) umfasst:

eine Führungsregion, wobei die Führungsregion so ausgelegt ist, dass sie in einen entsprechenden Abschnitt des Drohnenführungsabschnitts (126) eingreift, um zu ermöglichen, dass die mindestens eine Drohne (18) sich entlang des Drohnenführungsabschnitts (126) vom Drohneneintrittsende (122) zum Drohnenaustrittsende (124) bewegt.

10. System nach Anspruch 9, wobei die Dockingstation (10) ferner mindestens ein Elektroaufladungs-Sen-

- deelement (132) zum Senden eines Drahtlos-Ladesignals an die mindestens eine Drohne (18) zum Aufladen der mindestens einen Drohne (18) umfasst, wenn die mindestens eine Drohne (18) innerhalb einer Reichweite des Drahtlos-Ladesignals ist; und jede der mindestens einen Drohne (18) ein Elektroaufladungs-Empfangelement (134) zum Empfangen des Drahtlos-Ladesignals umfasst; wobei optional das Elektroaufladungs-Empfangelement (134) benachbart zur Führungsregion angeordnet ist; und/oder wobei optional das mindestens eine Elektroaufladungs-Empfangelement (134) der mindestens einen Drohne (18) für drahtlosen Eingriff mit dem mindestens einen Elektroaufladungs-Sendeelement (132) der Dockingstation (10) für Drohnen angeordnet ist, wobei das mindestens eine Elektroaufladungs-Sendeelement (132) der Dockingstation (10) für Drohnen in einem Innenvolumen der Andockwelle (120) angeordnet ist.
11. System nach Anspruch 9 und 10, wobei jede der mindestens einen Drohne (18) eine Empfangsregion definiert, die zum Aufnehmen eines Außenumfangs der Drohnenladestation (10) bemessen ist, derart dass die mindestens eine Führungsregion in den Drohnenführungsabschnitt (126) eingreift, der entlang der Außenfläche (128) der Drohnen-Andockwelle (120) angeordnet ist.
12. System nach einem der Ansprüche 10 und 11, wenn von Anspruch 10 abhängig, wobei das mindestens eine Elektroaufladungs-Empfangelement (134) der mindestens einen Drohne (18) eine Induktionsaufladungsantenne ist; oder wobei das mindestens eine Elektroaufladungs-Empfangelement (134) der mindestens einen Drohne (18) eine Resonanzauf Ladungsantenne ist.
13. System nach Anspruch 9, wobei jede der mindestens einen Drohne (18) eine Empfangsregion definiert, die zum Aufnehmen eines Außenumfangs der Drohnenladestation (10) bemessen ist, derart, dass die mindestens eine Führungsregion in den Drohnenführungsabschnitt (126) eingreift, der entlang der Außenfläche (128) der Drohnen-Andockwelle (120) ausgebildet ist.
14. System nach einem der Ansprüche 9 bis 13, wobei das Führungssystem zum Bewegen der mindestens einen Drohne (18) entlang des Drohnenführungsabschnitts (126) durch mindestens einen Motor ausgelegt ist, der zum Drehen der Andockwelle (120) ausgelegt ist.
15. System nach Anspruch 9, wobei die Dockingstation (10) ferner mindestens eine elektrisch leitende Oberfläche umfasst, die zur Kontaktaufladung mindes-

tens einer Elektrode der mindestens einen Drohne (18) angeordnet ist, wenn die Drohne (18) sich entlang des Drohnenführungsabschnitts (126) bewegt.

5

## Revendications

10

1. Station d'arrimage de drone (10) configurée pour recevoir au moins un drone (18), la station d'arrimage (10) comprenant :

15

un arbre d'arrimage (120) dimensionné pour se mettre en prise avec l'au moins un drone (18), l'arbre d'arrimage (120) ayant une extrémité d'entrée de drone (122) et une extrémité de sortie de drone (124) à l'opposé de l'extrémité d'entrée de drone (122) ; et

20

une portion de guidage de drone (126) disposée de manière hélicoïdale le long de l'arbre d'arrimage (120), la portion de guidage de drone (126) étant configurée pour se mettre en prise avec une région de guidage correspondante sur l'au moins un drone (18) pour permettre à l'au moins un drone (18) de se déplacer le long de la portion de guidage de drone (126) depuis l'extrémité d'entrée de drone (122) jusqu'à l'extrémité de sortie de drone (124).

25

30

2. Station d'arrimage de drone (10) selon la revendication 1, dans laquelle l'arbre d'arrimage (120) est formé en tant qu'une pièce unitaire.

35

3. Station d'arrimage de drone (10) selon la revendication 1 ou 2, dans laquelle l'arbre d'arrimage (120) est allongé.

40

4. Station d'arrimage de drone (10) selon l'une quelconque des revendications 1 à 3, dans laquelle la portion de guidage de drone (126) de l'arbre d'arrimage (120) est formée en tant qu'un filetage.

45

5. Station d'arrimage de drone (10) selon l'une quelconque des revendications 1 à 3, dans laquelle la portion de guidage de drone de l'arbre d'arrimage (120) est formée par des saillies.

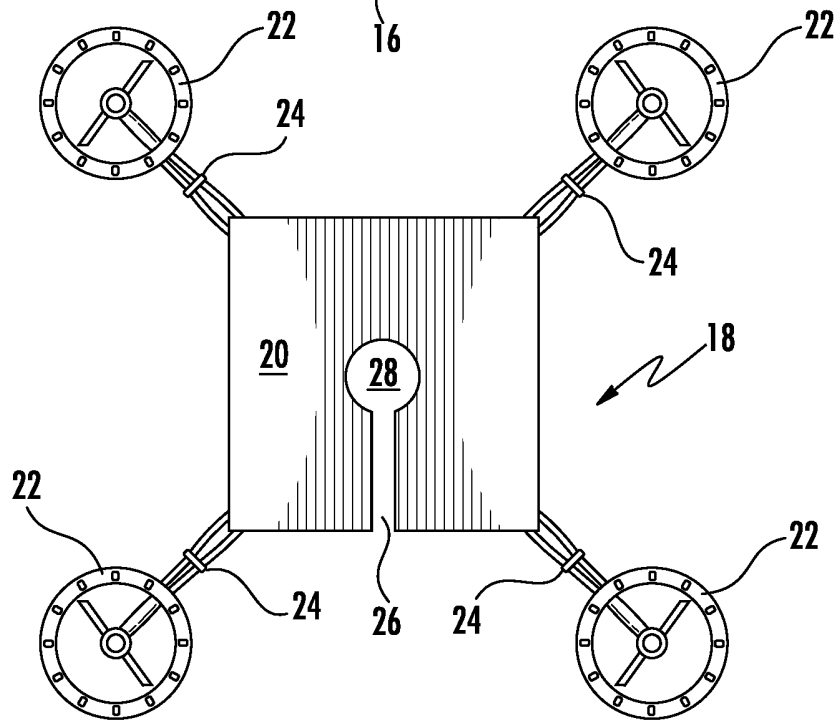
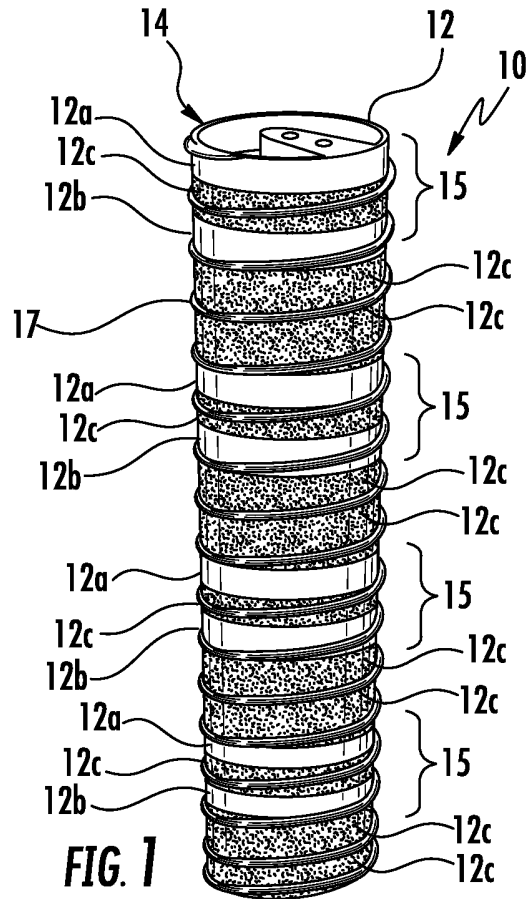
50

6. Station d'arrimage de drone (10) selon l'une quelconque des revendications 1 à 5, comprenant en outre :

55

au moins un élément de transmission de charge électrique (132) pour transmettre un signal de charge sans fil à l'au moins un drone (18) pour charger l'au moins un drone (18) lorsque l'au moins un drone (18) est à portée du signal de charge sans fil ; dans laquelle, facultativement, l'arbre d'arrimage (120) a un volume intérieur, et l'au moins un

- élément de transmission de charge électrique (132) est disposé dans le volume intérieur ; et/ou dans laquelle, facultativement, l'au moins un élément de transmission de charge électrique (132) est formé en faisant partie de la portion de guidage de drone (126) ; et/ou dans laquelle, facultativement, l'au moins un élément de transmission de charge électrique (132) est une antenne de charge inductive ou dans laquelle l'au moins un élément de transmission de charge électrique (132) est une antenne de charge de résonance.
7. Station d'arrimage de drone (10) selon l'une quelconque des revendications 1 à 6, dans laquelle l'arbre d'arrimage de drone (120) a une surface extérieure (128), la portion de guidage de drone (126) étant formée le long de la surface extérieure (128) ; et/ou dans laquelle la portion de guidage de drone (126) s'étend depuis l'extrémité d'entrée de drone (122) jusqu'à l'extrémité de sortie de drone (124) ; et/ou comprenant en outre au moins un moteur configuré pour permettre à l'arbre d'arrimage (120) de tourner pour déplacer l'au moins un drone (18) le long de l'au moins une portion de guidage de drone (126).
8. Station d'arrimage de drone (10) selon l'une quelconque des revendications 1 à 5 ou 7 lorsqu'elle ne dépend pas de la revendication 6, comprenant en outre au moins une surface électriquement conductrice pour charger par contact l'au moins un drone (18) au fur et à mesure que le drone (18) se déplace le long de la portion de guidage de drone (126).
9. Système de charge d'au moins un drone (18), le système comprenant :
- la station d'arrimage de drone (10) selon l'une quelconque des revendications 1 à 5 ; et au moins un drone (18), chacun de l'au moins un drone (18) comprenant :
- une région de guidage, la région de guidage étant agencée pour se mettre en prise avec une portion correspondante de la portion de guidage de drone (126) pour permettre à l'au moins un drone (18) de se déplacer le long de la portion de guidage de drone (126) depuis l'extrémité d'entrée de drone (122) jusqu'à l'extrémité de sortie de drone (124).
10. Système selon la revendication 9, dans lequel la station d'arrimage (10) comprend en outre au moins un élément de transmission de charge électrique (132) pour transmettre un signal de charge sans fil à l'au moins un drone (18) pour charger l'au moins un drone (18) lorsque l'au moins un drone (18) est à portée du signal de charge sans fil ; et
- chacun de l'au moins un drone (18) inclut un élément de réception de charge électrique (134) pour recevoir le signal de charge électrique ; dans lequel, facultativement, l'élément de réception de charge électrique (134) est disposé adjacent à la région de guidage ; et/ou dans lequel, facultativement, l'au moins un élément de réception de charge électrique (134) de l'au moins un drone (18) est disposé pour se mettre en prise sans fil avec l'au moins un élément de transmission de charge électrique (132) de la station d'arrimage de drone (10), l'au moins un élément de transmission de charge électrique (132) de la station d'arrimage de drone (10) étant disposé dans un volume intérieur de l'arbre d'arrimage (120).
11. Système selon l'une quelconque des revendications 9 et 10, dans lequel chacun de l'au moins un drone (18) définit une région de réception dimensionnée pour recevoir un périmètre extérieur de la station de charge de drone (10) de sorte que l'au moins une région de guidage se mette en prise avec la portion de guidage de drone (126) disposée le long de la surface extérieure (128) de l'arbre d'arrimage de drone (120).
12. Système selon l'une quelconque des revendications 10 et 11 lorsqu'elle dépend de la revendication 10, dans lequel l'au moins un élément de réception de charge électrique (134) de l'au moins un drone (18) est une antenne de charge inductive ; ou dans lequel l'au moins un élément de réception de charge électrique (134) de l'au moins un drone (18) est une antenne de charge de résonance.
13. Système selon la revendication 9, dans lequel chacun de l'au moins un drone (18) définit une région de réception dimensionnée pour recevoir un périmètre extérieur de la station de charge de drone (10) de sorte que l'au moins une région de guidage se mette en prise avec la portion de guidage de drone (126) formée le long d'une surface extérieure (128) de l'arbre d'arrimage de drone (120).
14. Système selon l'une quelconque des revendications 9 à 13, dans lequel le système de guidage est configuré pour déplacer l'au moins un drone (18) le long de la portion de guidage de drone (126) par au moins un moteur configuré pour faire tourner l'arbre d'arrimage (120).
15. Système selon la revendication 9, dans lequel la station d'arrimage (10) comprend en outre au moins une surface électriquement conductrice disposée pour charger par contact au moins une électrode de l'au moins un drone (18) au fur et à mesure que le drone (18) se déplace le long de la portion de guidage de drone (126).



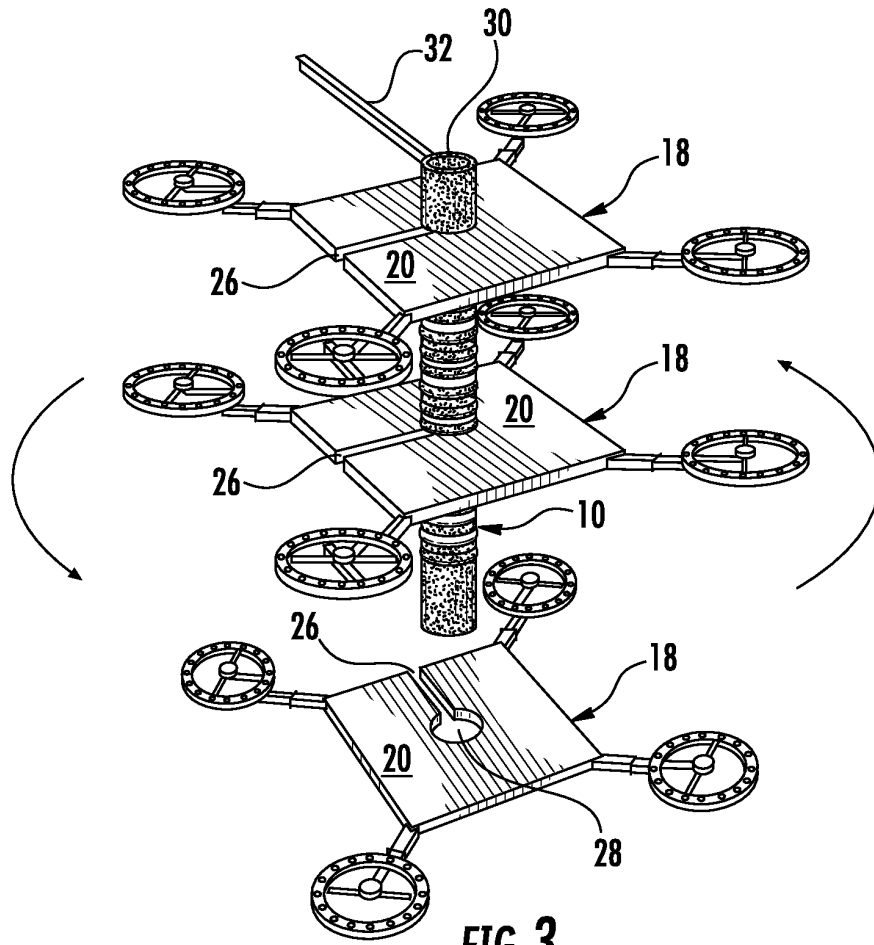


FIG. 3

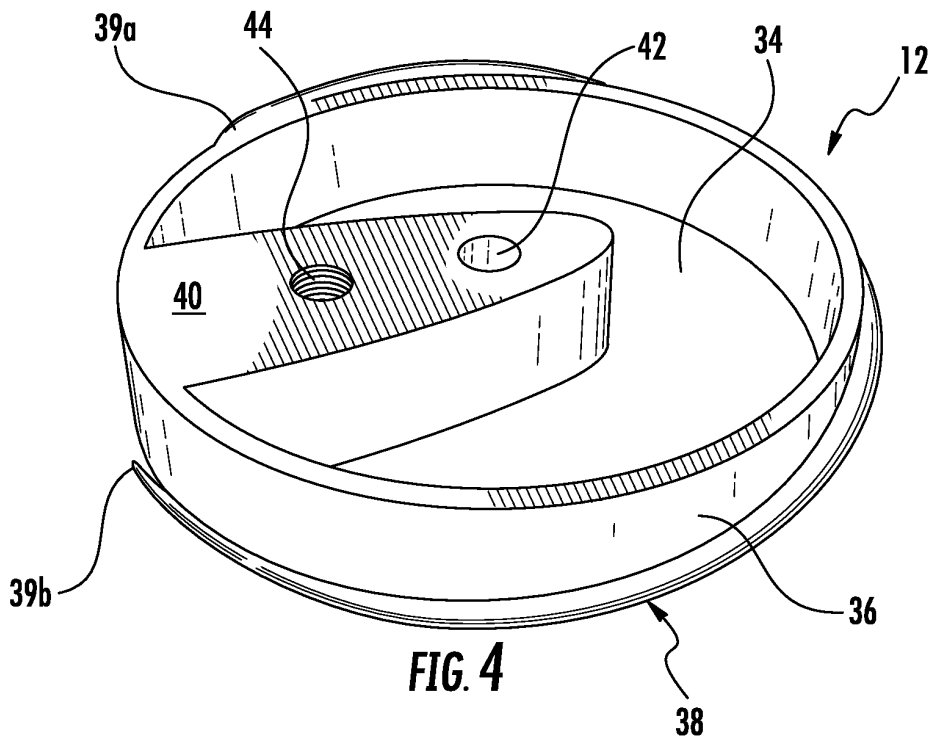


FIG. 4

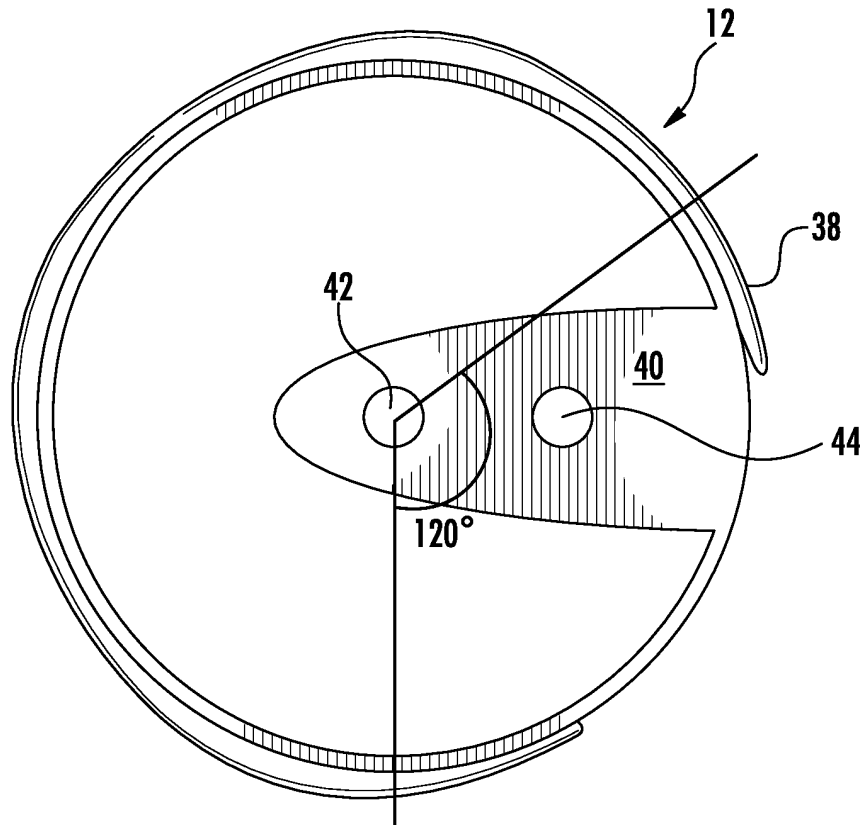


FIG. 5

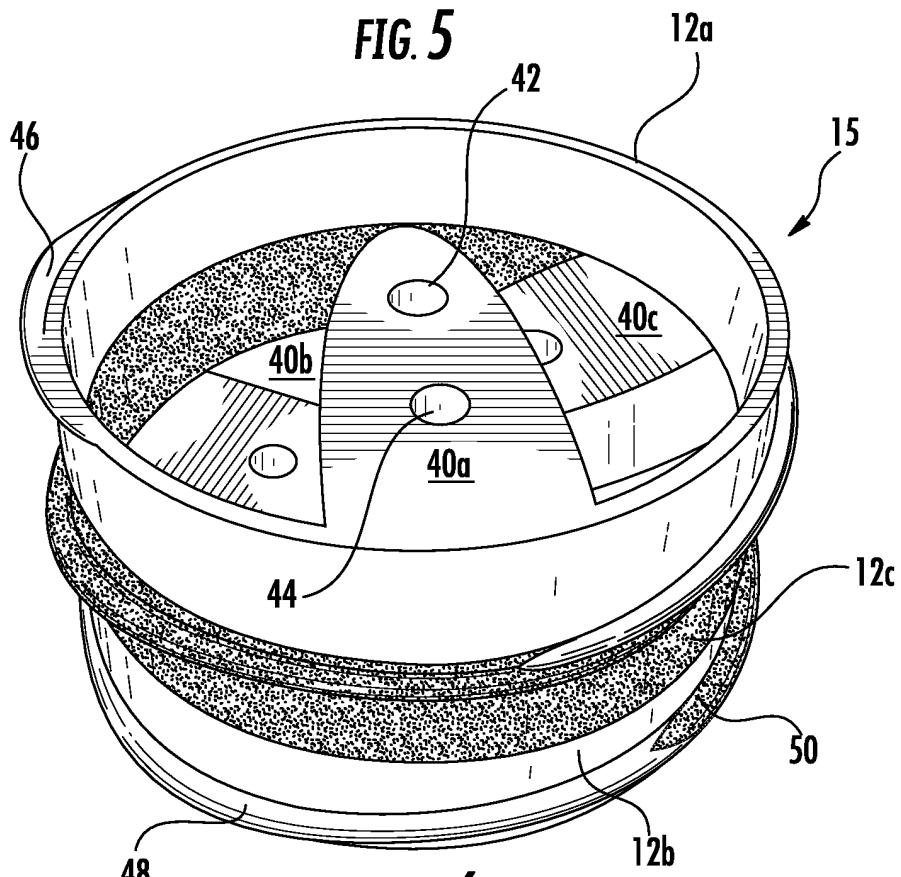


FIG. 6

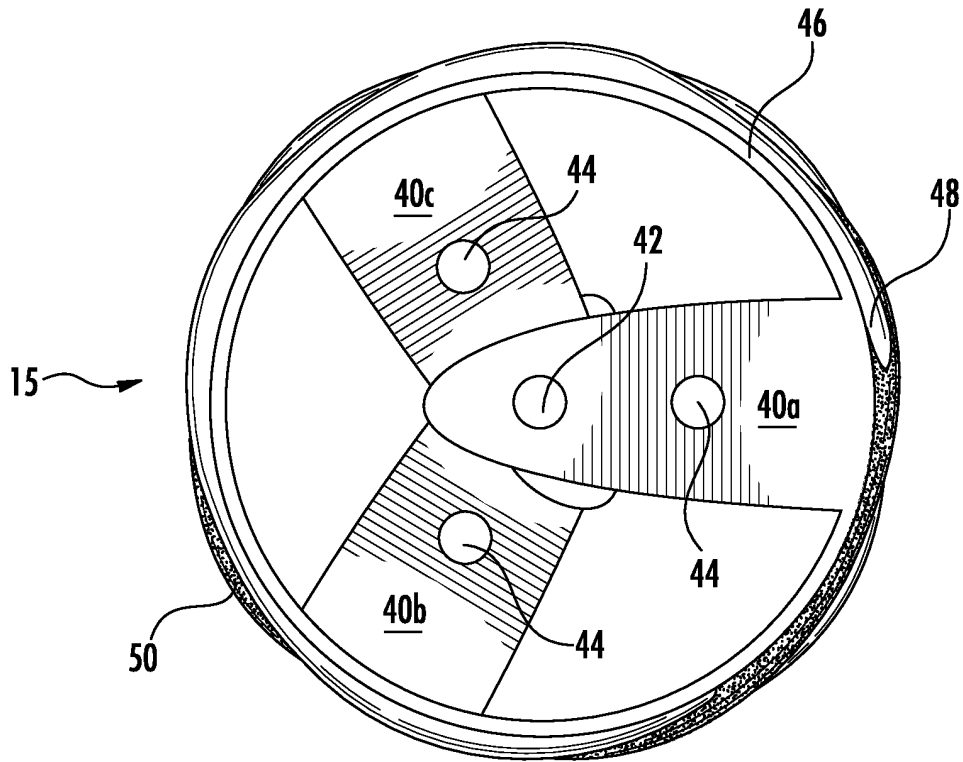


FIG. 7

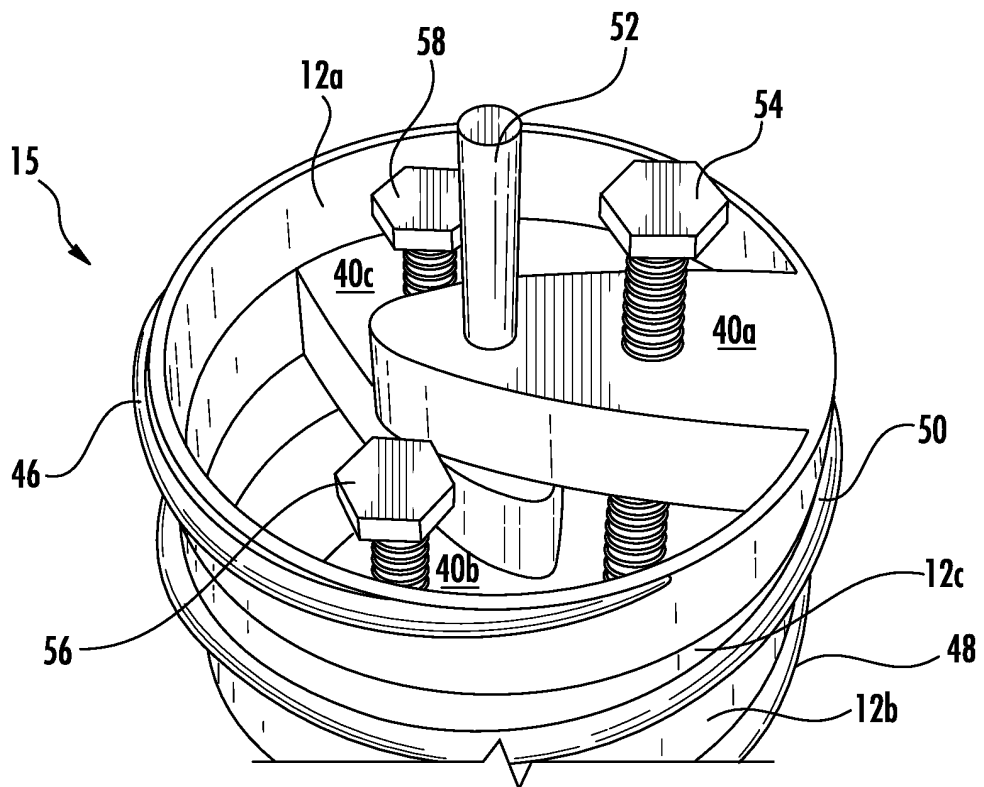


FIG. 8

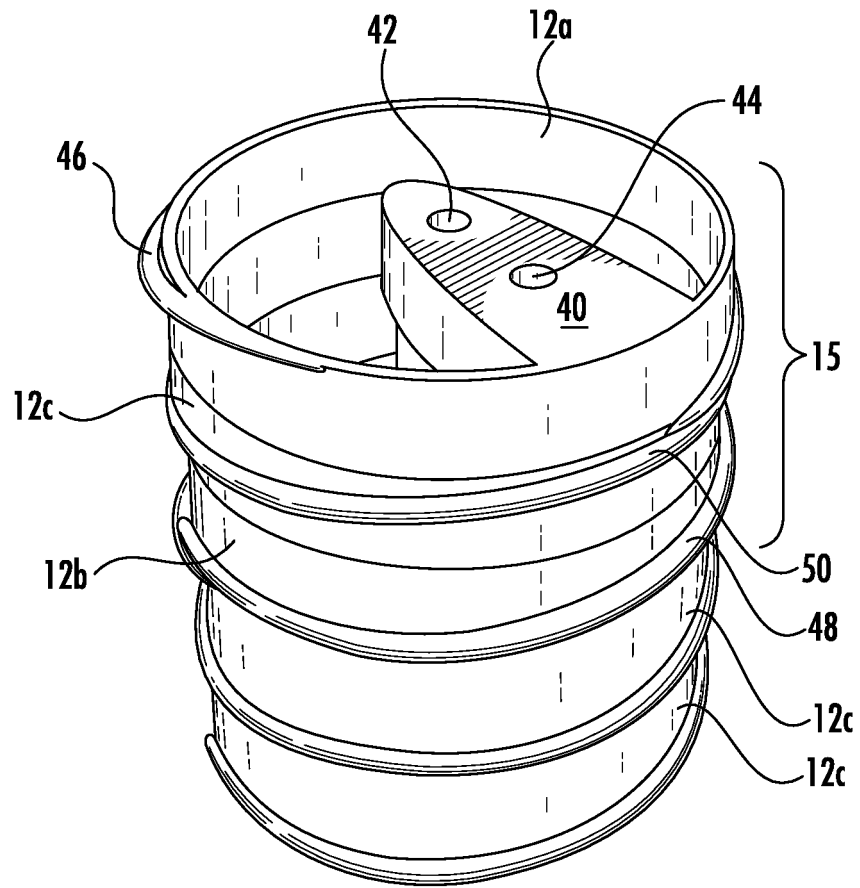


FIG. 9

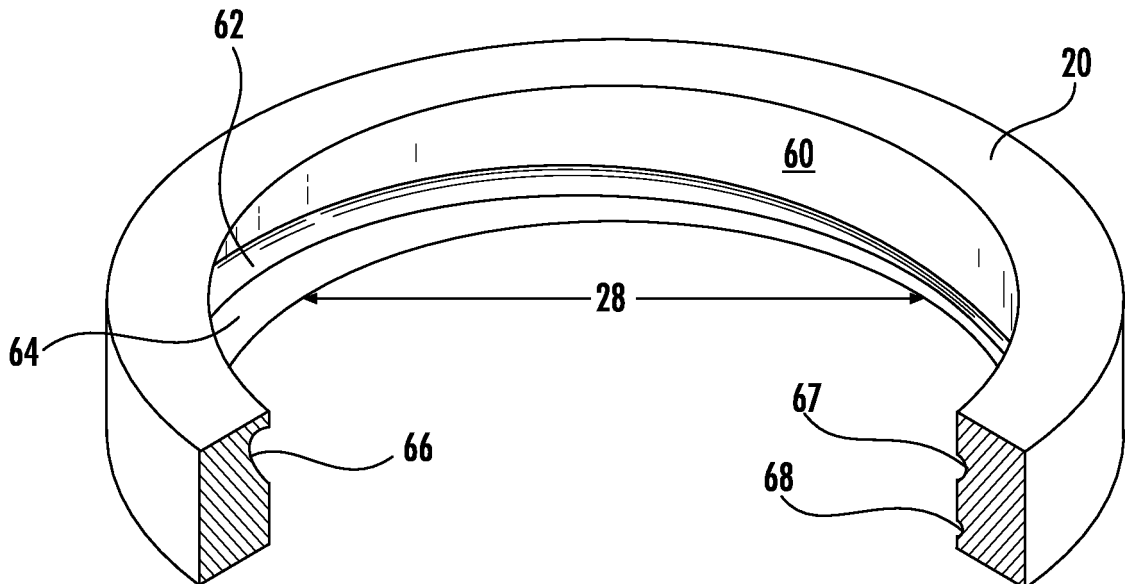


FIG. 10



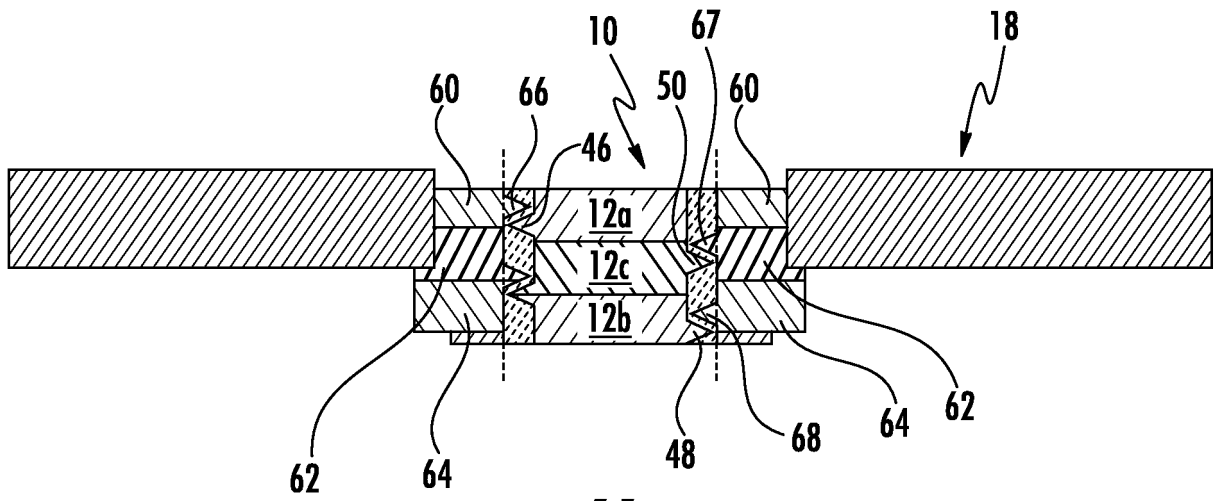


FIG. 11

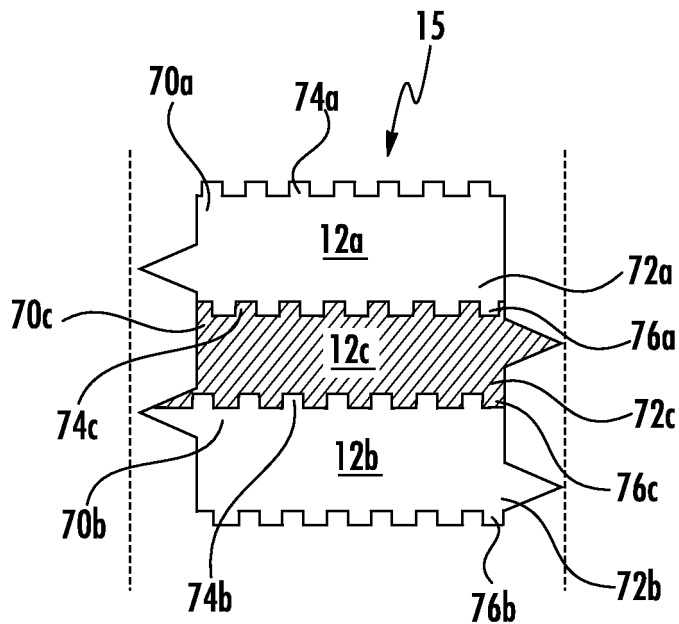
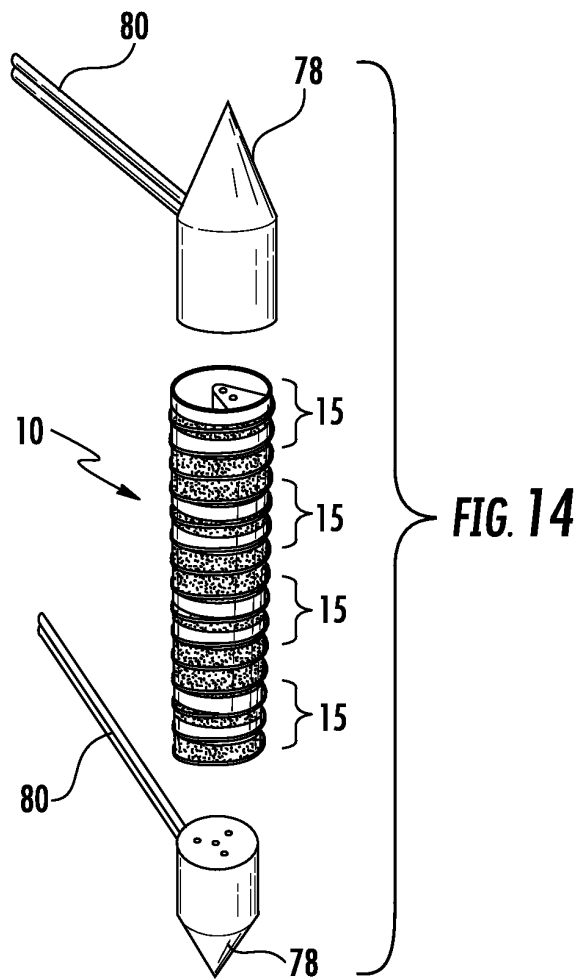
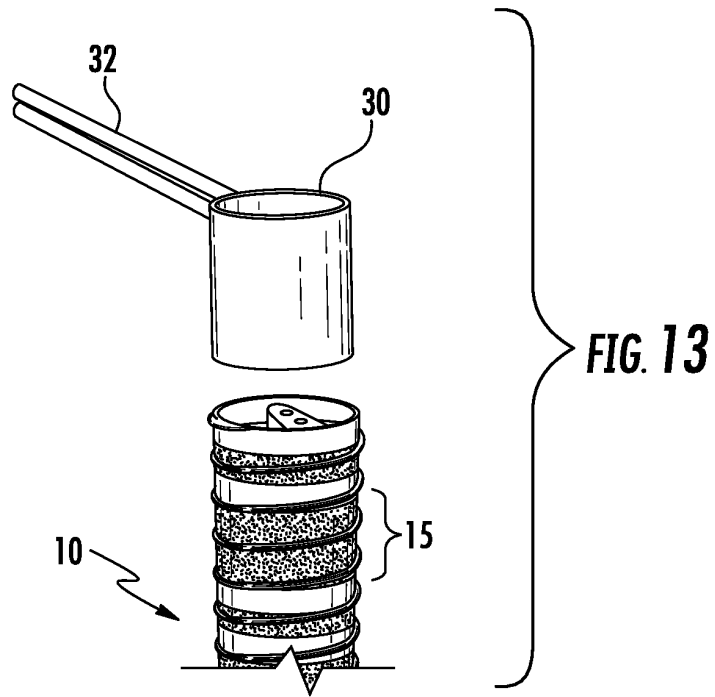


FIG. 12



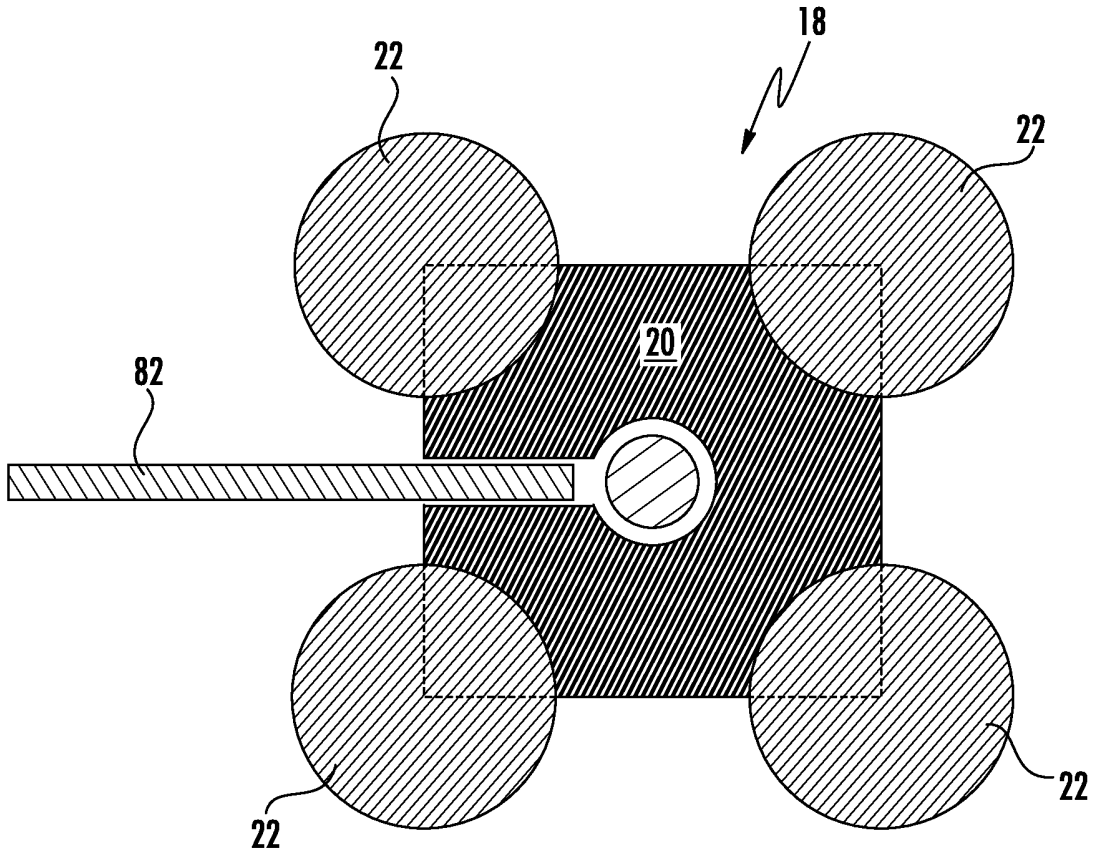


FIG. 15

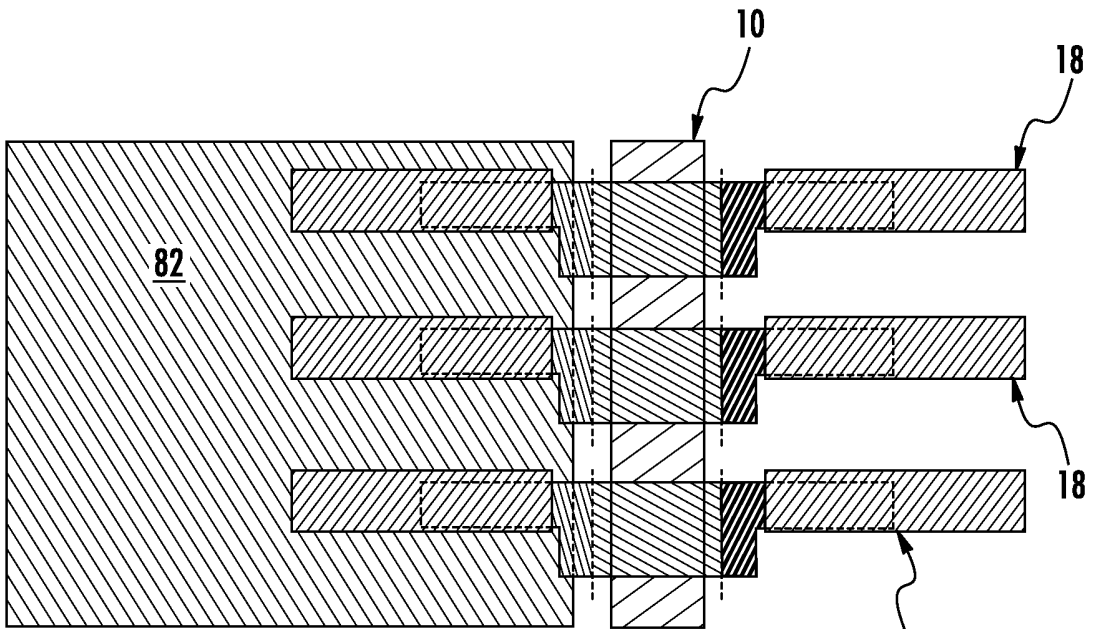


FIG. 16

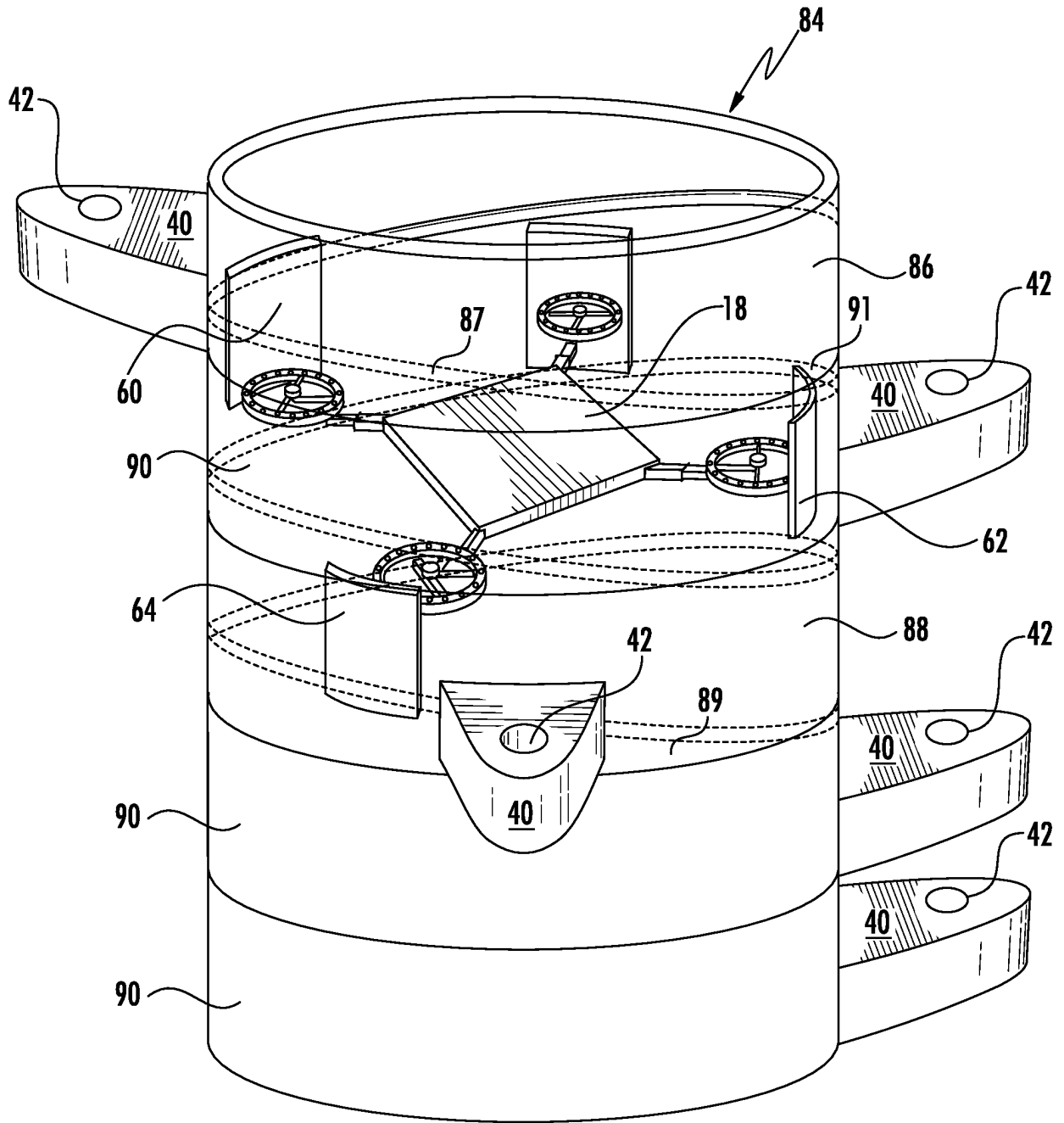
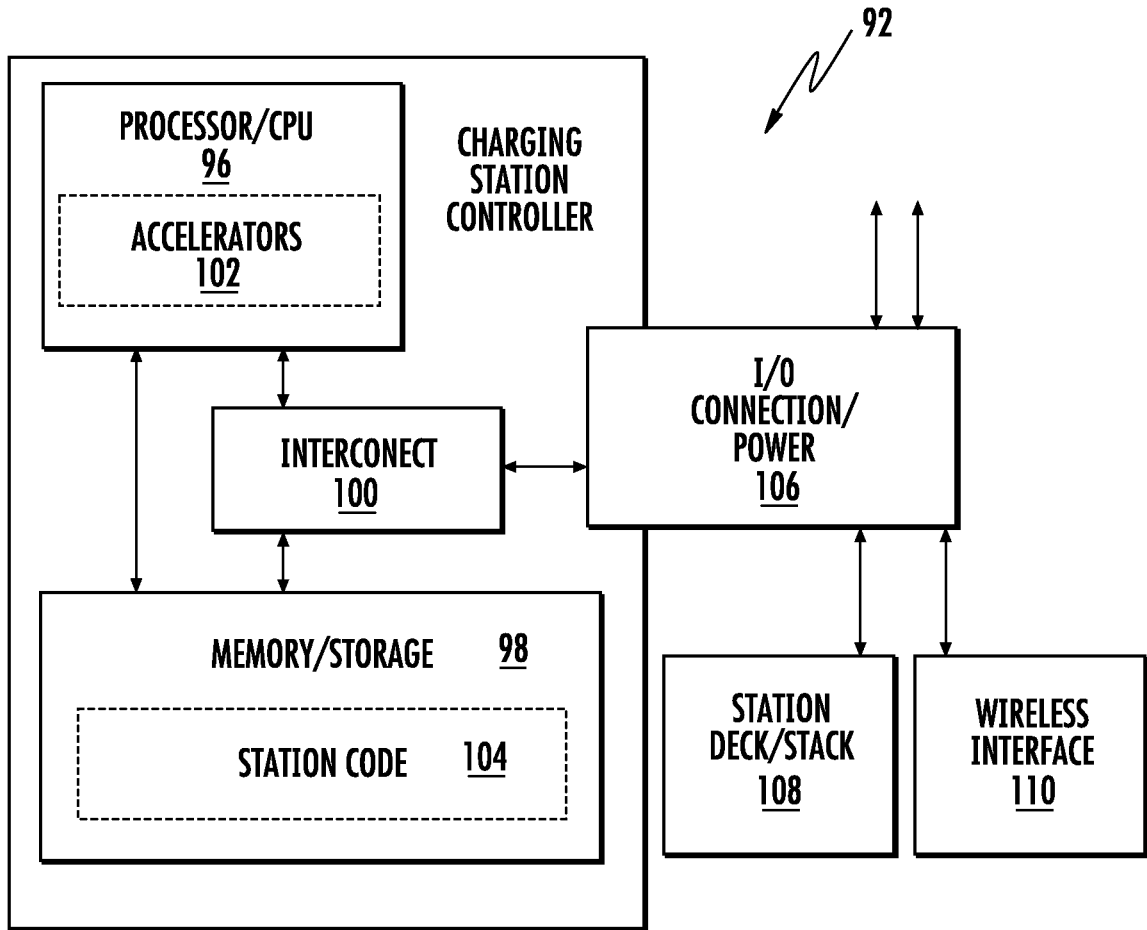
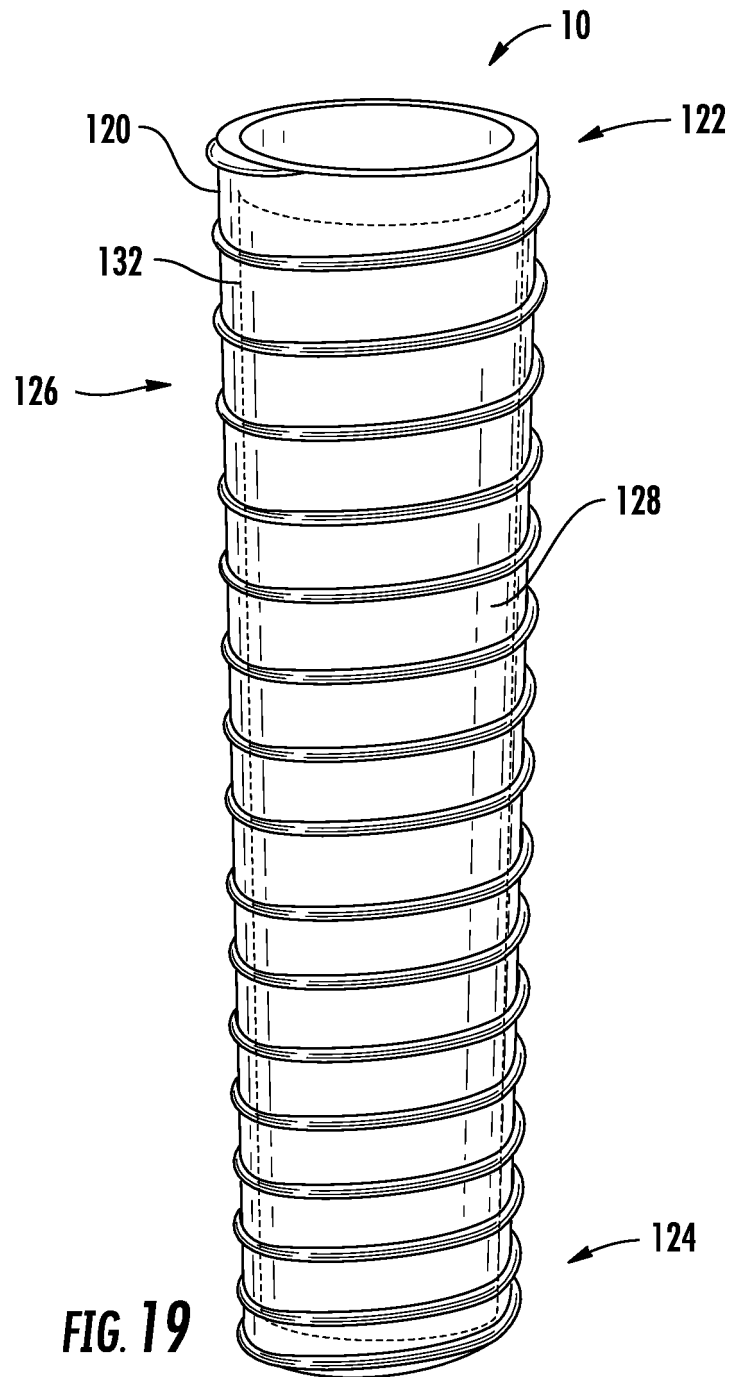


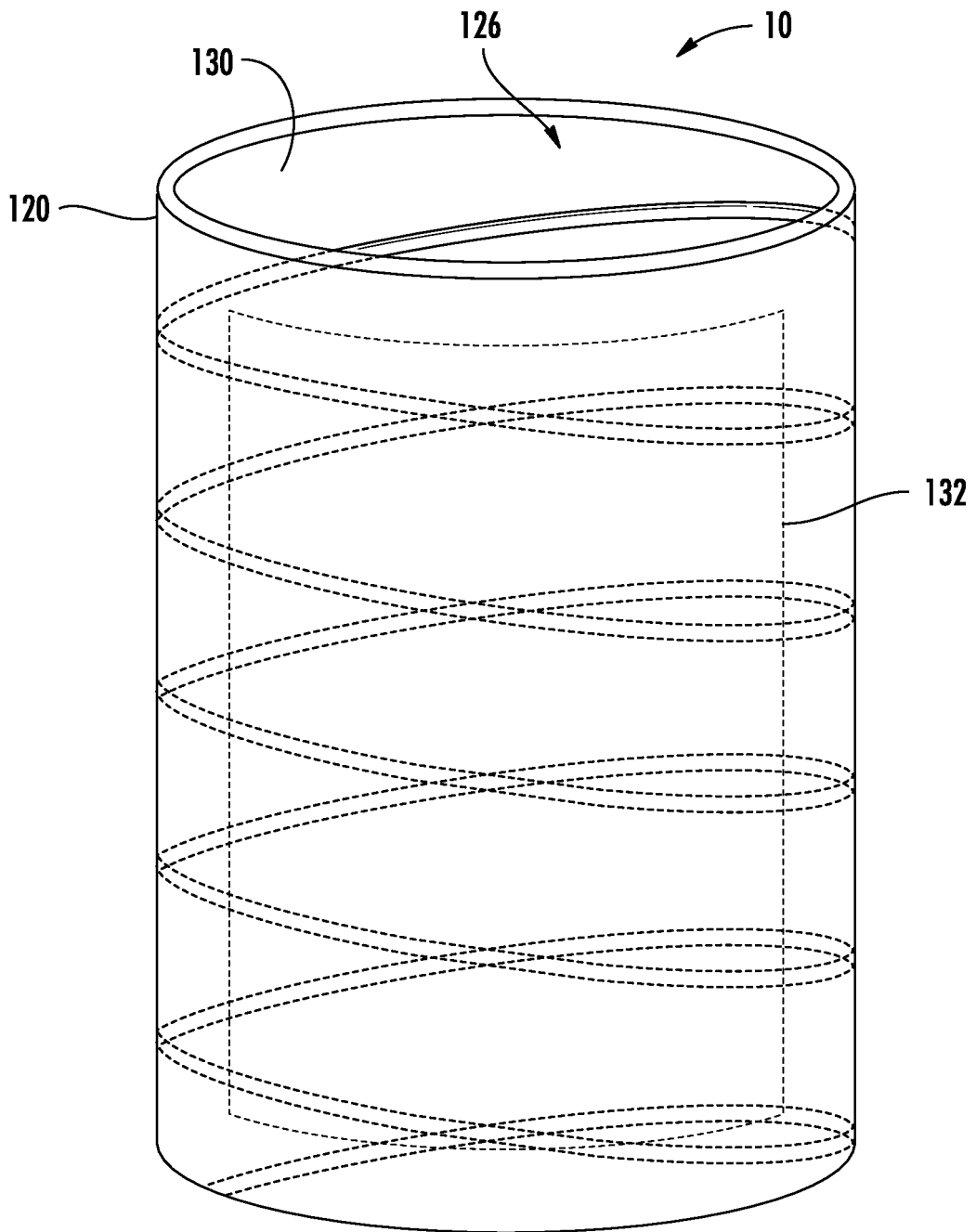
FIG. 17



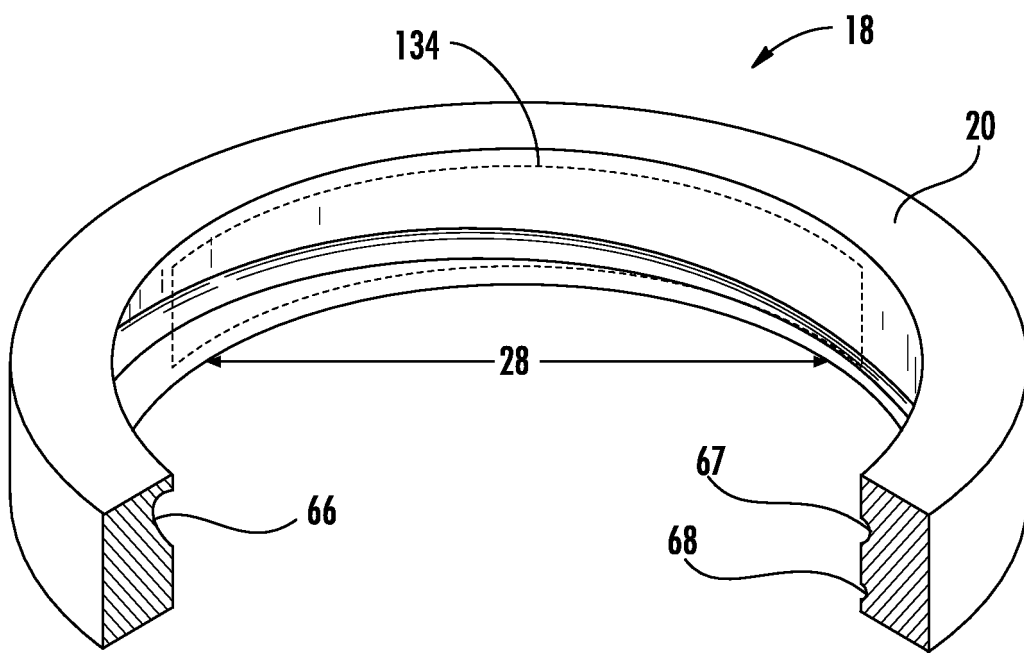
**FIG. 18**



**FIG. 19**

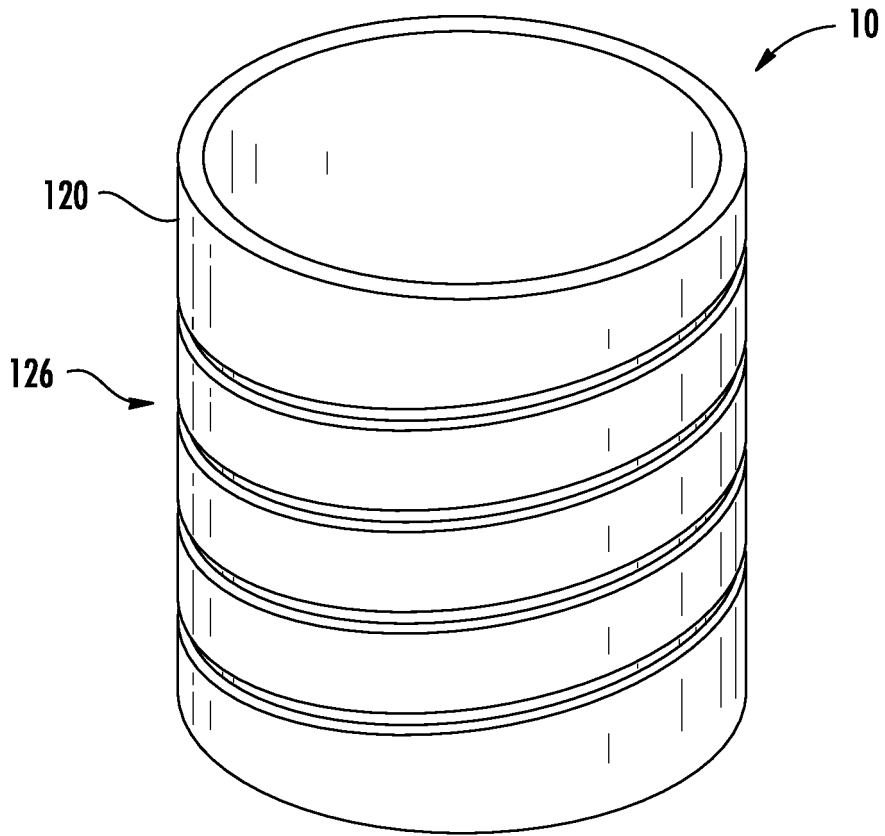


**FIG. 20**

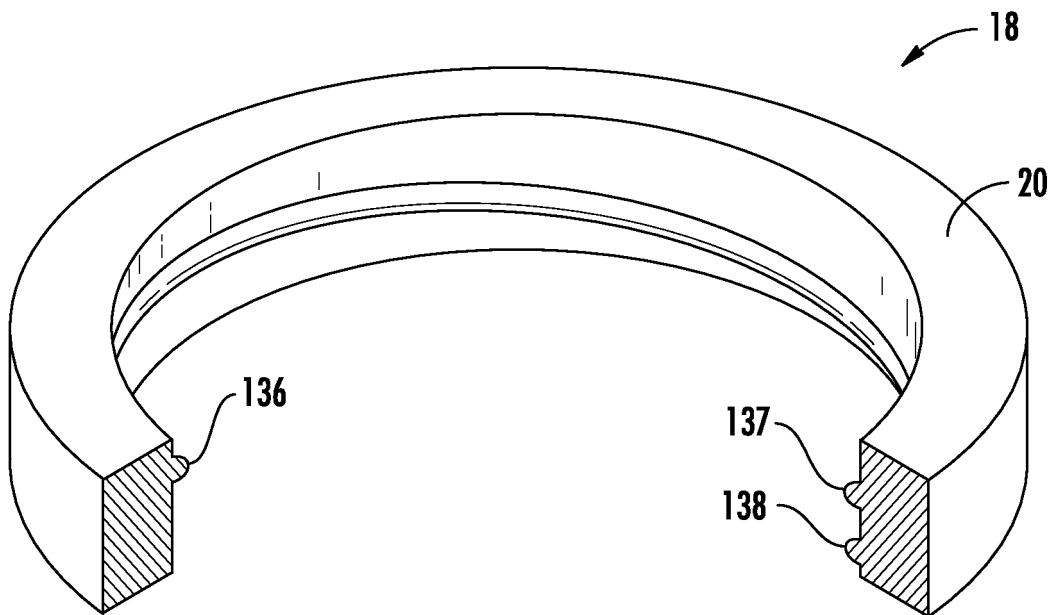


**FIG. 21**





**FIG. 22**



**FIG. 23**

**REFERENCES CITED IN THE DESCRIPTION**

*This list of references cited by the applicant is for the reader's convenience only. It does not form part of the European patent document. Even though great care has been taken in compiling the references, errors or omissions cannot be excluded and the EPO disclaims all liability in this regard.*

**Patent documents cited in the description**

- WO 2016137982 A1 [0004]