

(19) (KR)
(12) (B1)

(51) 。 Int. Cl. 6
H02P 8/14

(45) 2002 04 24
(11) 10 - 0316280
(24) 2001 11 19

(21) 10 - 1996 - 0002309 (65) 1996 - 0036286
(22) 1996 01 31 (43) 1996 10 28

(30) 95 - 50900 1995 03 10 (JP)

(73) 가 가 3

(72) 가 2 3 - 202

(74)

:

(54)

(M) , (M) (T)
(T0) .
CPU(1) (M)가 (T0) 1 (t1) (I) ,
(I) (A, B) (A, B) (8) . CPU(1) (I)
(A, B) (A, B) (Q) (T) ,
(T) (T0) ROM(7) , (T) 가
(T0) . CPU(1) 2 (t2) ,
(8a) .

1 가

2 가

3

4

5 가

6 A, B A

(1) ----- CPU,

(2) ----- ,

(6) ----- RAM,

(7) ----- ROM,

(9) ----- ,

(8a) ----- ,

(11) ----- ,

(12) ----- A/D ,

(13) ----- ,

(14) ----- ,

(15) ----- ,

(19) ----- ,

(A),(B) ----- ,

(M) ----- .

(勵磁相)

가

가

가

가

가

가

가

가

가

가

가

가

(脫調現象)

가
가

1

가

가

2

3

가

4

1

가

가
가

가

가

2

가
가
가

3 가 가

가 가

4 가 가

1 가 (2) (4) (2), (3), (4) (5) CPU(1)

RAM(6) RAM(6) ROM(7) CPU(1) CPU(1) (9) NCU(10)

(M) (8) (8) (M) (8) (M)

(8) (8a) (19) (8) CPU(1) (M)

가 2 (+A, -A +B, -B) , A B 가

(M) (8) CPL(1) CPU(1) (M) A , B

(11) (+A, -A, +B, -B) (+A) (6) (11) (Q)

(M) (Q) , A/D (12) CPU(1)

2 (M) (18) (g1)
 가 , (g1) (g2) (g2) (g3)
 (13a) (13)가 1 (16) (13a) (g5) (14)가
 , (g2) (g4) 2 (17) (15a)
 (15) (g6) (2)가 (15a) (15)가 ,

6) (g5) , (P) (M) (g2), 1 (1
 , 2 (13) (13) (M)
 (15) (M) (g2), 2 (17) (2)
 , (P) (2) (M) , 2 , (g6)

2 (P) (13) , (P)
 (15) , (T)가 (T)가 ,
 (M) (+A, -A, +B, -B) (T) (Q)
 (Q) 1 1 (3) (T) (Q)
 1 (t1) ROM(7)

(M) , (+A, -A, +B, -B) (I)
) , (M) (T0) 가 (4) , ()
 f) (I) (T0) , 2 (t2) ()
 ROM(7)
 (P) , CPU(1) (M) (f) ()
 T0) , 2 (t2) RAM(6) ()
 8)

(8)가 CPU(1) (8a) , (19)
 (+A, -A, +B, -B) (I) (8a)

(+A, -A, +B, -B) 가 (M)가 , (11)
 (Q) , A/D (12) A/D (12) (Q)
 CPU(1) CPU(1) (T)
 , 1 (t1) (T)

CPU(1) , 1 (t1) (T) , ROM(7) (T)
 (T0) (差分値) CPU(1) (T)
 (T) 가 (T0) CPU(1) , ROM(
 7) 2 (t2)

(8a) B, -B) . (8a) . (19) (M) (+A, -A, +

5 (M) , (8) CPU(1) , (f)가 가

(M) , (+A, -A, +B, -B) (T0) (4) .

(T0) , ROM(7) , 2 (t2) (I) (f) (M)

(I) 가 (T0) 4 (t4) CPU(1) (f)

(f) (8) , 4 (t4) (f)

(T) , CPU(1) (T) 1 (t1) , ROM(7)

(T0) (T) 가 CPU(1) CPU(1) (T)

ROM(7) 4 (t4) (f) , (f) (8)

(T0) , (T) (Q) , (f) (f) (I)

ROM(7) (I) (關數) , (T0) , (T)

(T0)

(M) , (3)

가 ,가 ,

가 가 ,

- (57)
1. 가 (M) (M) (T) , (T) 가 . (I)
 2. 1 , (T) (M) , (M) (I) (
 - 3.

가 (M) (T) , (T) , 가
 (M) (f)

4.

3 , (M) (I)
 (T) , (M) (f)

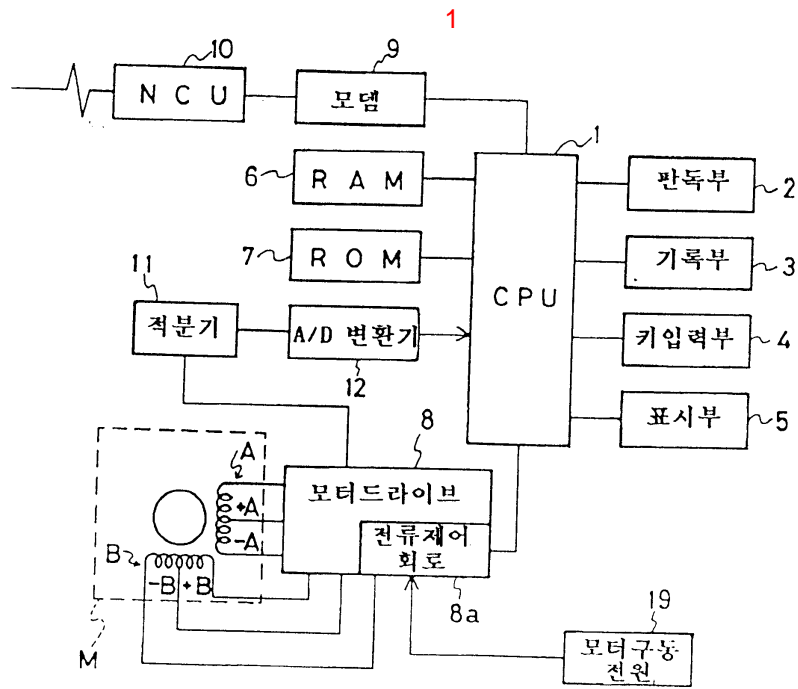

2

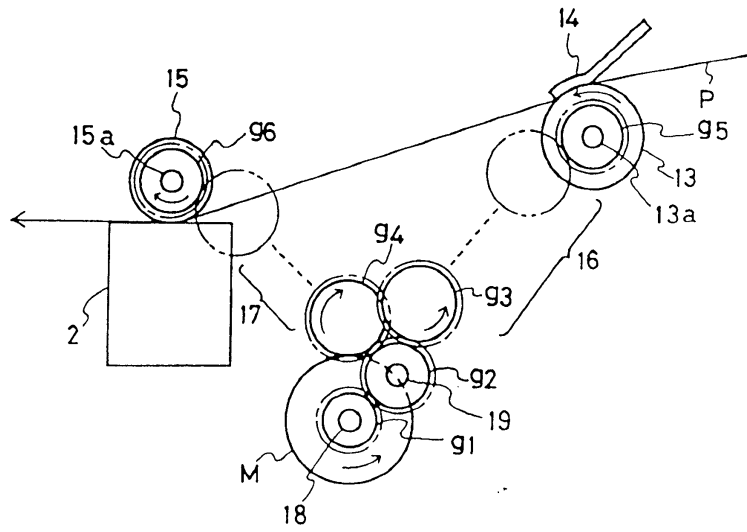

3

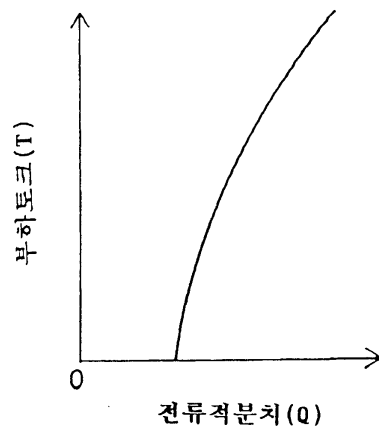

4

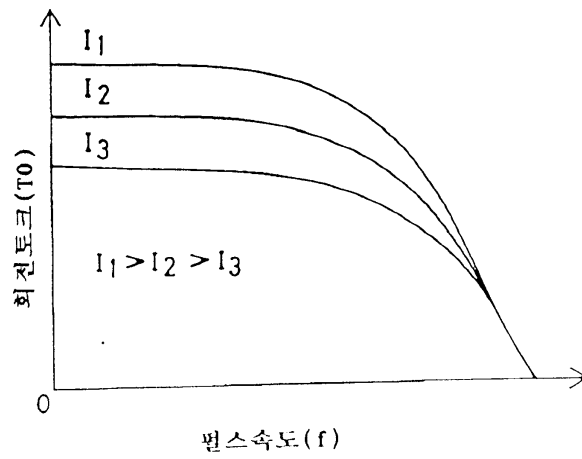

5

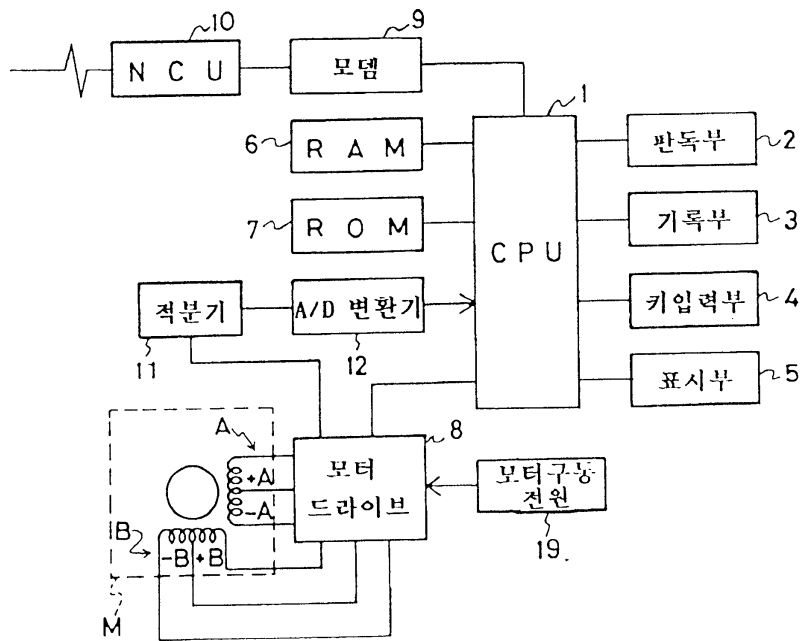

6

