



- (51) International Patent Classification:  
*D06F 37/26* (2006.01)    *D06F 39/08* (2006.01)
- (21) International Application Number:  
PCT/EP2013/076622
- (22) International Filing Date:  
13 December 2013 (13.12.2013)
- (25) Filing Language: English
- (26) Publication Language: English
- (30) Priority Data:  
12198891.9    21 December 2012 (21.12.2012)    EP
- (71) Applicant: **ELECTROLUX HOME PRODUCTS CORPORATION N.V.** [BE/BE]; Raketstraat 40, B-1130 Brussels (BE).
- (72) Inventors: **CINELLO, Mauro**; Electrolux Italia S.p.A., Corso Lino Zanussi 30, I-33080 Porcia (PN) (IT). **PEROSA, Vittorio**; Corso Lino Zanussi 30, I-33080 Porcia (PN) (IT). **DE PAOLI, Stefano**; Electrolux Italia S.p.A., Corso Lino Zanussi 30, I-33080 Porcia (PN) (IT). **COLOMBERA, Giovanni**; Electrolux Italia S.p.A., Corso Lino Zanussi 30, I-33080 Porcia (PN) (IT). **MONACCHI, Marco**; Electrolux Italia S.p.A., Corso Lino Zanussi 30, I-

33080 Porcia (PN) (IT). **CLARA, Marco**; Electrolux Italia S.p.A., Corso Lino Zanussi 30, I-33080 Porcia (PN) (IT). **PESSOT, Marco**; Electrolux Italia S.p.A., Corso Lino Zanussi 30, I-33080 Porcia (PN) (IT). **MOROSI, Davide**; Electrolux Italia S.p.A., Corso Lino Zanussi 30, I-33080 Porcia (PN) (IT).

- (74) Agents: **FRARE, Paolo** et al.; Electrolux Italia S.p.A., Corso Lino Zanussi 30, I-33080 Porcia (PN) (IT).
- (81) Designated States (*unless otherwise indicated, for every kind of national protection available*): AE, AG, AL, AM, AO, AT, AU, AZ, BA, BB, BG, BH, BN, BR, BW, BY, BZ, CA, CH, CL, CN, CO, CR, CU, CZ, DE, DK, DM, DO, DZ, EC, EE, EG, ES, FI, GB, GD, GE, GH, GM, GT, HN, HR, HU, ID, IL, IN, IR, IS, JP, KE, KG, KN, KP, KR, KZ, LA, LC, LK, LR, LS, LT, LU, LY, MA, MD, ME, MG, MK, MN, MW, MX, MY, MZ, NA, NG, NI, NO, NZ, OM, PA, PE, PG, PH, PL, PT, QA, RO, RS, RU, RW, SA, SC, SD, SE, SG, SK, SL, SM, ST, SV, SY, TH, TJ, TM, TN, TR, TT, TZ, UA, UG, US, UZ, VC, VN, ZA, ZM, ZW.
- (84) Designated States (*unless otherwise indicated, for every kind of regional protection available*): ARIPO (BW, GH, GM, KE, LR, LS, MW, MZ, NA, RW, SD, SL, SZ, TZ,

[Continued on next page]

(54) Title: LAUNDRY MACHINE WITH VERSATILE TUB

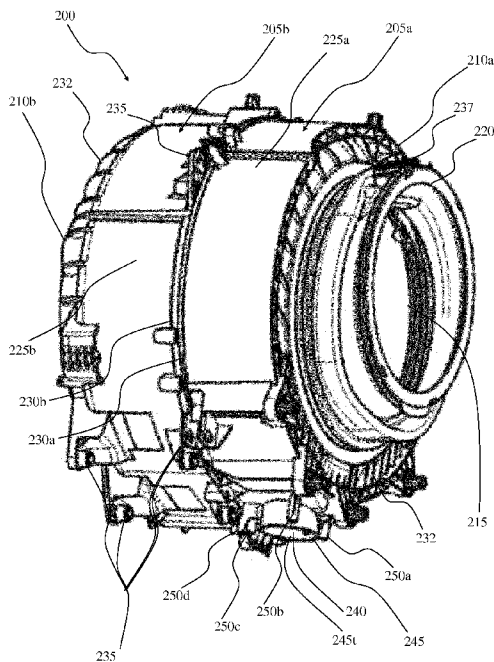


FIG. 2A

(57) Abstract: Present invention relates to a laundry machine (100) for treating laundry provided with a tub (200) which comprises a discharge hole (240) for draining liquid out of the tub (200), and a plurality of drain-connection elements (245a, 250a, 250b, 250c, 250d). The laundry machine (100) further comprises a discharge duct (300; 500; 600) fluidly connected to the discharge hole (240) for collecting liquid drained from the tub (200), and fixed to the tub by at least one of the drain-connection elements. The plurality of drain-connection elements (245a, 250a, 250b, 250c, 250d) comprises at least two different types of drain-connection elements (245a, 250a, 250b, 250c, 250d), each one adapted for fixing a corresponding type of discharge duct to the tub (200) by means of a corresponding connection arrangement.



UG, ZM, ZW), Eurasian (AM, AZ, BY, KG, KZ, RU, TJ, TM), European (AL, AT, BE, BG, CH, CY, CZ, DE, DK, EE, ES, FI, FR, GB, GR, HR, HU, IE, IS, IT, LT, LU, LV, MC, MK, MT, NL, NO, PL, PT, RO, RS, SE, SI, SK, SM, TR), OAPI (BF, BJ, CF, CG, CI, CM, GA, GN, GQ, GW, KM, ML, MR, NE, SN, TD, TG).

**Published:**

- *with international search report (Art. 21(3))*
- *before the expiration of the time limit for amending the claims and to be republished in the event of receipt of amendments (Rule 48.2(h))*

**Declarations under Rule 4.17:**

- *as to applicant's entitlement to apply for and be granted a patent (Rule 4.17(ii))*

### LAUNDRY MACHINE WITH VERSATILE TUB

The present invention relates to laundry machines, such as laundry washing machines and laundry washing/drying machines, both for domestic and professional use. More particularly, the present invention relates to a laundry machine having a  
5 versatile tub, allowing multiple types of connections of a discharge duct of the draining system.

A household and/or professional laundry machine – such as a laundry washing machine and a laundry washing/drying machine – typically comprises a washing tub, enclosed in a casing, that houses a rotatable drum in which the laundry  
10 can be loaded/unloaded, and accessible by a user for loading/unloading the laundry through a loading/unloading aperture selectively closable by a door.

During operation, washing liquid (*e.g.*, water or water mixed with washing/rinsing products) is introduced in the tub of the laundry machine by means of an inlet hydraulic system fluidly connected to the tub. Subsequently, a washing  
15 phase starts in which the laundry previously loaded into the rotatable drum is washed thanks to the chemical reactions exerted by the washing liquid, supported by the tumbling action caused by the rotation of the drum.

At the end of the washing phase, waste liquid (*i.e.*, the washing liquid mixed with dirt particles removed from the laundry and possibly fluff lost therefrom) is  
20 drained from the washing tub before starting a rinsing phase of the washed laundry typically followed by a spin-drying phase. Furthermore, also additional waste liquid expelled from the washed laundry during the spin-drying or rinsing phase is discharged at the end of the laundry machine operation in order to avoid waste liquid stagnation, correlated unpleasant smells and dirt deposits within the drum and/or the  
25 tub.

Therefore, the laundry machine is provided with a draining system adapted to drain waste liquid during the operation of the laundry machine. Particularly, such draining system is selectively fluidly connected to the tub of the laundry machine in order to receive the waste liquid.

30 The draining system usually comprises a discharge duct (such as a flexible

hose), which, at one of its ends, is connected to a discharge hole at the bottom of the washing tub for discharging the waste liquid. At the other end, the discharge duct is connected to a pump assembly adapted to drain the waste liquid from the washing tub. Such a pump assembly usually comprises a filter (for blocking small objects and/or fluff) and a drain pump (that pumps liquid out of the washing tub). A valve member is usually provided in the discharge duct in order to fluidly separate during a washing procedure the draining system from the tub. Finally, a discharge hose connects a pump assembly outlet to a house draining pipe system for disposing the waste liquid.

5  
10 Typically, the discharge hole is surrounded by a drain collar, which surrounds the discharge hole and is advantageously connected to the discharge duct of the draining system.

As known, the discharge duct has to be properly connected to the tub in order to avoid waste liquid leakages, which may lead to laundry machine malfunctions (e.g., due to waste liquid leakages on electrics or electronics component parts), annoying drawbacks (e.g., waste liquid dispersed on the floor). Many types of discharge ducts are known, each featuring peculiar shapes and constitutive materials. Therefore, it is necessary to use a specific tub adapted to the particular discharge duct type to be mounted thereto.

15  
20 For example, a flexible hose may be fastened to the drain collar of the tub by means of a hose clamp. Conversely, in the case of a manifold made of hard material, such as a plastic polymer, a hose clamp does not provide a suitable fastening (since the plastic polymer does not deform as the elastomeric material does upon the fastening of the hose clamp) and other expedients have to be applied, such as  
25 screwing the manifold to the tub at the drain collar.

Consequently, the discharge hole and the portion of the tub in which the same is provided has to be specifically manufactured according to the discharge duct type (i.e., made of elastomeric or hard material) to be connected to the same, which requires different manufacturing lines or different manufacturing periods on a same  
30 manufacturing line. This requires an accurate laundry machines manufacturing

planning, which may cause manufacturing costs to increase.

The Applicant has tackled the problem of devising a satisfactory solution able to provide a versatile laundry machine tub adapted to be connected with discharge ducts for draining waste liquid essentially regardless of a type thereof.

5 Applicant has found that by providing the washing tub of a laundry machine with at least two types of drain-connection elements, each one adapted for fixing a corresponding type of discharge duct to the tub by means of a corresponding connection arrangement, it is possible using a single type of tub in association with different types of discharge ducts, which reduces the production complexity, the  
10 necessity of using different machines, tools and moulds, and, therefore, the overall productions costs.

One aspect of the present invention proposes a laundry machine for treating laundry comprising a tub, the tub comprising a discharge hole for draining liquid out of the tub, and a plurality of drain-connection elements

15 The laundry machine further comprises a discharge duct fluidly connected to the discharge hole for collecting liquid drained from the tub, and fixed to the tub by at least one of the drain-connection elements. The plurality of drain-connection elements comprises at least two different types of drain-connection elements, each one adapted for fixing a corresponding type of discharge duct to the tub by means of  
20 a corresponding connection arrangement.

In an advantageous embodiment of the invention, the tub further comprises a front half-shell and a rear half-shell. The discharge hole is provided on the front half-shell, on the rear half shell, or partly on the front half-shell and partly on the rear half-shell.

25 Preferably, the at least one type of the at least two different types of drain-connection elements comprises one or more drain-connection elements protruding from the tub, and the discharge duct further comprises one or more matching portions matching a corresponding one of the one or more drain-connection elements protruding from the tub.

30 In an advantageous embodiment, at least one of the one or more drain-

connection elements protruding from the tub is fixed to a corresponding matching portion of the discharge duct by a fastening element

In a preferred embodiment at least one drain-connection element of the one or more drain-connection elements protruding from the tub and a corresponding  
5 matching portion of the discharge duct are transversal with respect to other drain-connection elements and other matching portions, respectively.

Preferably, at least one of the one or more drain-connection element protruding from the tub comprises a hollow appendage adapted to engage with the at least one respective fastening element.

10 More preferably, at least one matching portion of the one or more matching portions comprises a through-hole adapted to the insertion of the at least one respective fastening element.

Advantageously, the laundry machine further comprises a drain collar protruding outwardly from the tub at a periphery of the discharge hole.

15 Preferably, the discharge duct comprises a wall adapted to encircle or to be encircled by a predetermined portion of the drain collar.

Advantageously at least one drain-connection element of the at least two different types of drain-connection elements is provided on the drain collar.

Preferably, the at least one drain-connection element provided on the drain  
20 collar comprises a threaded portion or bayonet elements provided on the drain collar and adapted to engage with a complementary threaded portion or bayonet element provided on the discharge duct.

In an advantageous embodiment, at least one drain-connection element provided on the drain collar comprises a sacrificial part provided on the drain collar  
25 and adapted to be used for welding the discharge duct to the tub.

Preferably, on an external side of the wall of the discharge duct at least a seat adapted to house at least one clamp member is provided, and the clamp member is adapted to tighten the wall against the at least one drain-connection element provided on the drain collar.

30 In an advantageous embodiment, the discharge duct is made of a hard

polymer.

In a different advantageous embodiment the discharge duct is made of an elastomeric material.

5 These and others features and advantages of the solution according to the present invention will be better understood by reading the following detailed description of some embodiments thereof, provided merely by way of exemplary and non-limitative examples, to be read in conjunction with the attached drawings, wherein:

10 **Figure 1** is an isometric view of a laundry machine in which the present invention may be implemented;

**Figure 2A** is an isometric view of a tub of the laundry machine of **Figure 1** according to an embodiment of the present invention;

**Figure 2B** is an enlarged view of a lower part of the tub of **Figure 2A** according to an embodiment of the present invention;

15 **Figure 3** is an exploded view of a manifold made of hard material according to an embodiment of the present invention;

**Figures 4A** shows the manifold of **Figure 3** while being mounted to the tub of **Figure 2A**;

20 **Figures 4B** shows the manifold of **Figure 3** mounted to the tub of **Figure 2A**;

**Figures 5A** shows another manifold of hard material according to an embodiment of the present invention;

**Figures 5B** is a partial cross-sectional and enlarged view of the manifold of **Figure 5A** associated with the tub of **Figure 2A**;

25 **Figures 6A** shows a flexible hose according to an embodiment of the present invention; and

**Figures 6B** show the flexible hose of **Figure 6A** mounted to the tub of **Figure 2A**.

30 With reference to the drawings, **Figure 1** is an isometric view of a laundry machine **100** in which the present invention may be implemented.

The laundry machine **100** is a machine for treating laundry (such as a laundry washing machine, a laundry washing/drying machine, *etc.*) of the front-loading type. Anyway, it should be apparent from the following description that laundry machines of the top-loading type may also benefit from the solution  
5 according to the present invention.

In the example at issue, the laundry machine **100** comprises a preferably substantially parallelepiped-shaped casing or cabinet **105** that encloses a washing tub, or simply tub **200** preferably substantially cylindrically-shaped (which is visible in **Figure 2**), wherein the laundry is treated, along with any other component of the  
10 laundry machine **100** necessary for its operation (*e.g.*, hydraulic, electronic and electromechanical apparatuses known in the art and, therefore not herein described for sake of conciseness).

Particularly, the tub **200** houses a rotatable drum **110** preferably substantially cylindrical-shaped, which, in operation, rotates about an axis **A** in order to tumble the  
15 laundry to be washed.

In the example of **Figure 1**, in order to allow a user to access the tub **200** and the inside of the drum **110** (for loading/unloading the laundry), a loading/unloading opening **115** is advantageously provided on a front side of the laundry machine **100**. The loading/unloading opening **115** is closable by a door **120**, which is, preferably,  
20 hinged to the casing **105** by means of a hinge (not shown in the figure). The door **120** is adapted to pivot from a closed position – wherein the door **120** closes the loading/unloading opening **115**, impeding access to the drum **110** – to an open position – wherein the door **120** is pivoted to an angle, preferably, equal to, or greater than, 90° with respect to the closed position – allowing access to the drum **110**.

In addition, preferably, although not limitatively, on a top portion of the casing **105** a user interface **125** is provided. Preferably, although not limitatively, the user interface **125** may comprise a control panel **125a** for selecting laundry treatment parameters (*e.g.*, type of washing/drying cycle, washing liquid temperature, rotation speed for the drum **110**, *etc.*) and a drawer **125b** for loading laundry-treating  
25 products (*e.g.*, detergents, softeners, bleachers, *etc.*).  
30



Turning now to **Figures 2A** and **2B**, there is shown an isometric view of the tub **200** of the laundry machine **100** and an enlarged view of a lower part of the tub **200**, respectively, according to an embodiment of the present invention.

The tub **200** has preferably a substantially cylindrical shape and is made of waterproof material which is also able to withstand operating temperatures and chemicals reactions promoted by washing liquid during the laundry machine operation. For example, the tub **200** may be made of a suitable plastic polymer, such as calcium carbonate-filled polypropylene.

Advantageously, although not limitatively, the tub **200** comprises a front half-shell **205a** and a rear half-shell **205b**, each having substantially the shape of an hollow cylinder.

In the example at issue, the front half-shell **205a** comprises a foreside **210a**, which substantially has a discoid shape. Advantageously, the foreside **210a** is provided with a front opening **215**, which is adapted to be aligned with the loading/unloading opening **115** provided in the casing **105**, and with a corresponding opening of the drum **110** (once the tub **200** is positioned inside the casing **105**). Moreover, in order to achieve a watertight connection between the loading/unloading opening **115** and the front opening **215** (in order to avoid leakages of washing liquid into the casing **105**), a bellows **220**, preferably made of an elastomeric and waterproof material, is mounted in a watertight manner (such as by glueing, by welding, by interference fitting *etc.*) to both a border of the tub front opening **215** and a border of the loading/unloading opening **115**.

The front half-shell **205a** comprises a front cylindrical sidewall **225a**, which extends substantially transversal from an outer periphery of the foreside **210a**. Advantageously, the front sidewall **225a** ends with a front half-shell border or flange **230a**, which is adapted to match a corresponding, rear half-shell border or flange **230b** of the rear half-shell **205b**.

The rear half-shell **205b** comprises a backside or backwall **210b**, which also substantially has a discoid shape. Advantageously, the backside **210b** is provided with a shaft opening (not shown). In such shaft opening advantageously it is inserted

a rotor shaft (not shown) attached to the drum **110** and rotatably connected (directly or by means of transmission elements such as a transmission belt) to an electric motor (also not shown) comprised in the laundry machine **100** in order to rotate the drum **130** during operation.

5           The rear half-shell **205b** comprises a rear cylindrical sidewall **225b** that extends substantially transversal from an outer periphery of the backside **210b**. The rear sidewall **225b** ends with the rear half-shell border **230b**, which matches with the front half-shell border **230a** of the front half-shell **205a**.

10           The foreside **210a**, the backside **210b**, and the two cylindrical sidewalls **225a** and **225b** may advantageously be provided with ribs **232** adapted to increase structural strength of the half-shells **205a** and **205b**. The foreside **210a**, the backside **210b**, and the two sidewalls **225a** and **225b** are preferably provided with fastening elements **235** protruding externally therefrom. For example, the fastening elements **235** may comprise treaded slots for screws or bolts and/or anchoring protrusions  
15 typically adapted to connect the tub **200** with a number of coil springs and/or shock-absorbers (not shown in the figures) through which the tub **200** is suspended in floating manner inside the casing **105**.

20           A washing liquid inlet port **237** is advantageously provided in a top portion of the bellows **220** (alternatively a different inlet port may be provided in tub **200**) and is fluidly connected to an inlet hydraulic system (not shown in the figures) in order to supply washing liquid in the tub **200** during the laundry machine **100** operation.

25           In the example at issue, a discharge hole **240** is advantageously provided at the bottom of the tub **200**, for example in a lower portion of the front sidewall **225a**; the discharge hole **240** serves as outlet for waste liquid. Anyway, it should be noted that the discharge hole **240** could be provided in the rear half-shell **205b** as well, or even the discharge hole **240** could be split between the two half-shells **205a** and **205b** (thus being provided partly along each one of the borders **230a** and **230b**); in general, the discharge hole **240** may be provided where it results to be more useful (*i.e.*, according to the position of other component parts inside the casing **105**).

30           Advantageously, the discharge hole **240** is preferably surrounded by a

cylindrical wall, forming a discharge hole collar or drain collar **245**, which protrudes, outwards from the tub **200** at a periphery of the discharge hole **240**, and has a free end that delimits a collar bottom aperture **245t** (*i.e.*, opposite to the discharge hole **240** in the front sidewall **225a**).

5           In the solution according to an embodiment of the present invention, the drain collar **245** is provided with a plurality of drain-connection elements adapted to the connection to the tub **200** of a discharge duct **300**, **500** or **600** (shown in **Figures 3**, **5A** and **6A**, respectively) in a variety of manners. The plurality of drain-connection elements comprises different connection elements adapted to connect together the  
10 drain collar **245** and the discharge duct **300**, **500** or **600** for collecting the waste liquid; different types of connections are supported, each of which depends on a type of the discharge duct **300**, **500** or **600** used (as will be described in the following). For example, the drain collar **245** may be provided at once with any combination of sets of receptacles for screws and/or bolts, bayonet mounting elements, threaded  
15 portions, snap-fitting members, sacrificial parts (*e.g.*, for welding of the discharge duct **300** or **500**), *etc.*

          In the example at issue, as best shown in **Figures 2A** and **2B**, drain-connection elements comprise a number of hollow appendages preferably internally threaded or adapted to be threaded by a self-threading screw, such as three hollow  
20 appendages **250a**, **250b** and **250c** that protrude from the tub **200** around the drain collar **245**, and a fourth hollow appendage **250d**, preferably internally threaded or adapted to be threaded by a self threading screw, that is provided in the proximity of the drain collar **245**, and is formed with an axis that is transversal, preferably orthogonal, with respect to the axis of the hollow appendages **250a**, **250b** and **250c**.  
25 As shown in the figures, the hollow appendages **250a**, **250b**, **250c** and **250d** have substantially the shape of a hollow cylinder, but other shapes, such as hollow prisms or a hollow frustoconical shapes, are not excluded.

          At least one hollow appendage **250a**, **250b**, **250c** and **250d** is advantageously designed for engaging with a threaded fastening element. For example, at least one  
30 hollow appendage **250a**, **250b**, **250c** and **250d** may serve as female receptacle for

screws or bolts. Alternatively or in addition, at least one hollow appendage **250a**, **250b**, **250c** and **250d** may be provided with hooking elements (such as properly shaped slots) adapted to engage corresponding snap-fitting members (such as lugs) provided on the discharge duct **300**, **500** or **600**. As an alternative, the hollow appendages **250a**, **250b**, **250c** and **250d** may be adapted to engage different fastening elements; for example, the hollow appendages **250a** and **250d** may be adapted to serve as female receptacle for screws while the hollow appendages **250b** and **250d** may be adapted to engage corresponding snap-fitting members.

Advantageously, although not limitatively, the three hollow appendages **250a**, **250b** and **250c** are spaced apart from the drain collar **245**, being connected thereto through a respective reinforcement and connection element, such a connection rib **255**. In this way, a collar band **245a** of the drain collar **245** ranging from its free end (*i.e.*, in correspondence of the collar bottom aperture **245t**) to the connection ribs **255** remains advantageously clear and easily reachable; thus, such collar band **245a** may be used as(for) further drain-connection element for achieving a coupling between the drain collar **245** and the discharge duct **300**, **500** or **600** (as will be discussed in detail later on). Alternatively, one or more (up to all) of the hollow appendages **250a**, **250b** and **250c** may be formed adjacent (*i.e.*, in contact with) the drain collar **245** (and possibly formed integral therewith) or completely separated therefrom.

Advantageously, although not limitatively, one or more hollow appendage **250a**, **250b**, **250c** and **250d** may be provided formed in the half-shell **205b** or **205a** opposite to the half-shell **205a** or **205b** in which the drain collar **245** is provided. In the example at issue, the fourth hollow appendage **250d** may be provided on the rear half-shell **205b** at the rear border **230b** thereof in a position proximal to the drain collar **245** once the two half-shells **205a** and **205b** are associated together. In the case the drain collar **245** is formed partly in the front half-shell **205a** and partly in the rear half-shell **205b**, hollow appendages **250a**, **250b**, **250c** and **250d** may be formed in both the half-shells **205a** and **205b**.

During a manufacturing phase of the laundry machine **100**, the two half-shells **205a** and **205b** are joined together, with the drum **130** enclosed therein, by matching

and coupling the corresponding borders **230a** and **230b** in any suitable manner (*e.g.*, by welding); in this way, the tub **200** rotatably houses the drum **130**.

Considering now **Figure 3**, it is an exploded view of a drain discharge duct or manifold **300** made of hard material according to an embodiment of the present invention.

The manifold **300** is made of hard material such as a suitable plastic polymer (*e.g.*, again calcium carbonate-filled polypropylene) and comprises a first hollow portion **305a** preferably formed with a substantially cylindrical shape, and a second hollow portion **305b** preferably having a substantially frustoconical shape (although further portions or alternative portions featuring other shapes are not excluded). The second hollow portion **305b** is fluidly connected, through its smallest base, substantially transversal to the first hollow portion **305a** at an end thereof. Both the first hollow portion **305a** and the second hollow portion **305b** may be formed in a single piece (*e.g.*, may be produced in a single cast) or the manifold **300** may be formed by an interconnection of separated first hollow portion **305a** and second hollow portion **305b**.

At an opposite free end of the first hollow portion **305a** a preferably circular drain-side aperture **310** is provided, which is adapted to engage a pump assembly (not shown in the figures) for draining waste liquid from the manifold **300** and, possibly, the tub **200** of the laundry machine **100**.

At a free end of the second hollow portion **305b**, a preferably circular tub-side aperture **315** is provided. Advantageously, the tub-side aperture **315** may comprise a tub-side wall **315a** and a holding rib **315b**, which may be adapted to encompass and hold, respectively, a valve member **320** that may be provided for separating the cool waste liquid collected in the manifold **300** from the warm washing liquid contained in the tub **200** during the laundry machine **100** operation.

The valve member **320** may comprise a substantially ring-shaped sealing gasket **325** and a buoyant element such as a cap **330**.

Advantageously, although not limitatively, such sealing gasket **325** is made of a resilient material and designed to fit, in a watertight manner, the space defined by

the tub-side wall **315a** and the tub-side holding rib **315b** (to which the sealing gasket **325** may possibly be glued or attached in any other suitable way). The sealing gasket **325** comprises a tab **325a** protruding downwards (*i.e.*, towards the inside of the second hollow portion **305b** when the valve member **320** is mounted in the manifold **300**) from a lower portion of the sealing gasket **325**. The sealing gasket **325** comprises a substantially circular gasket aperture **325b** adapted to be watertight closed by the cap **330**.

In the example at issue, the cap **330** is preferably, but not limitatively, made of hard material (such as a plastic polymer). The cap **330** is preferably substantially cylindrically shaped with a substantially hemispherical top **330a**, which is encircled by a flat abutment border **330b**. The abutment border **330b** is adapted to abut a lower rim of the gasket aperture **320b** achieving the watertight closure of the tub-side aperture **315**.

The cap **330** preferably comprises an eyelet **330c** protruding laterally from the cap **330**, for example at mid-height of a side of the cap **330**. The tab **325a** of the sealing gasket **325** is adapted to be inserted into the eyelet **330c**, thus allowing the cap **330** to pivot about the tab **325a**, during operation, from a closed position, in which the abutment border **330b** abuts the gasket aperture **320b**, to an open position, in which the cap **330** is substantially transversal to the gasket aperture **320b**.

Anyway, it should be noted that embodiments according to the present invention may be implemented in laundry machines exploiting types of valve member other than the one herein described or, ultimately, implementing a discharge duct **300**, **500** or **600** lacking of such valve member.

In the solution according to an embodiment of the present invention, the manifold **300** further comprises a plurality of matching portions, such as wings formed along the tub-side wall **315a** and protruding therefrom, each advantageously having a trough-hole; in the example at issue, three matching portions or wings **335a**, **335b** and **335c** are provided. In addition, along the periphery of the drain-side aperture **310** a further matching portion or wing **335d** is provided. It should be noted that, since the drain-side aperture **310** is transversal to the tub-side aperture **315**, the

wing **335d** has an axis that is transversal, preferably orthogonal, with respect to the ones of the wings **335a**, **335b** and **335c**.

In alternative embodiments according to the present invention the matching portion may be formed on a border of the tub-side aperture, instead protruding from  
5 its wall.

Turning jointly to **Figures 4A** and **4B**, which show the manifold **300** while being mounted to the tub **200** and the manifold **300** mounted to the tub **200**, respectively, the mounting of the manifold **300** to the tub **200** is now described.

In the example at issue, the drain collar **245** is inserted into the tub-side  
10 aperture **315**, since the former has a diameter smaller than the diameter of the latter (although other embodiments in which the drain collar **245** has a diameter larger than, or substantially equal to, the tub-side aperture **315** are not excluded). Advantageously, the drain collar **245** is inserted into the tub-side aperture **315** until the free end of the drain collar **245** abuts an upper portion of the sealing gasket **325**.

In the solution according to an embodiment of the present invention,  
15 advantageously, preferably each matching portion or wing **335a**, **335b**, **335c** and **335d** of the manifold **300** is designed to match a corresponding drain-connection element provided on the tub **200**, such as the corresponding hollow appendage **250a**, **250b**, **250c** and **250d**, as the drain collar **245** is inserted into the tub-side aperture  
20 **315**.

Alternatively, the wings **335a**, **335b**, **335c** and **335d** on the manifold **300** may be in a different number with respect to the hollow appendages **250a**, **250b**, **250c** and **250d** provided on the tub **200** – in order to be adapted to the connection with other  
25 tubs (not shown) having a different number or disposition of hollow appendages –, in which case only part of the wings **335a**, **335b**, **335c** and **335d** matches corresponding hollow appendages **250a**, **250b**, **250c** and **250d**.

Subsequently, suitable fastening elements, such as screws **405**, may be inserted, each one into the through hole of the corresponding wings **335a**, **335b**, **335c** and **335d** and engaged with the corresponding hollow appendage **250a**, **250b**, **250c**  
30 and **250d**, once the manifold **300** is coupled to the drain collar **245**. In some

embodiments according to the present invention, only a part of the hollow appendages **250a**, **250b**, **250c** and **250d** may be engaged with screws **405** while the remaining part of the hollow appendages **250a**, **250b**, **250c** and **250d** may be left unengaged. For example, the tub **200** may be connected to a tub (not shown) having  
5 a lower number of matching portions than the hollow appendages **250a**, **250b**, **250c** and **250d** provided on the tub **200**.

The matching pair of wing **335d** - internally-threaded hollow appendage **250d**, which is transversal, preferably orthogonal, with respect to the other pairs of wings **335a**, **335b** and **335c** - hollow appendages **250a**, **250b** and **250c** ensures a  
10 greater robustness in the coupling between the manifold **300** and the drain collar **245** than having all the pairs parallel one to another, since the fastening elements provided (*e.g.*, the screws **405**) act in two distinct fastening directions.

Once the screws **405** have been fastened, the manifold **300** results firmly connected to the drain collar **245** and thus to the whole tub **200**. Thanks to the  
15 tightening strength provided by the fastened screws **405**, the free end of the drain collar **245** advantageously abuts an upper portion of the sealing gasket **325** in a watertight manner, thus ensuring a leakage-less fluid communication between the manifold **300** and the tub **200**. Preferably, the drain-side aperture **310** may be fluidly connected to a pump assembly (not shown in the figures) an outlet of which is fluidly  
20 connected to a discharge hose for disposing the waste liquid in a house draining pipe system.

The laundry machine **100** may advantageously comprise a recirculation system (not shown in the figures) adapted to reuse part of drained waste liquid, during the laundry machine **100** operation in order to reduce liquid consumption  
25 (particularly, water consumption). In this case, a recirculation duct may be selectively connected to the filter-pump assembly outlet (for example, in parallel with the draining hose) for receiving part of the waste liquid to be fed to the recirculation system.

In addition or in alternative, embodiments according to the present invention  
30 may be provided with various drain-connection elements. For example, an external



face of the collar band **245a** (or a portion thereof) may be threaded so as to match a complementary engagement thread advantageously provided on an internal face of the tub-side wall **315a**. Thanks, to the matching threads it is possible to screw the manifold **300** to the drain collar **245** until a watertight engagement between the two  
5 is reached.

In other embodiments according to the present invention, for attaining the watertight connection between the manifold **300** and the drain collar **245**, bayonet mounting elements may be provided as drain-connection elements. For example, on the collar band **245a** male bayonet elements, such as one or more radially-protruding  
10 pins, may be provided, while complementary female bayonet elements, such as substantially L-shaped slots, may be provided in the tub-side wall **315a**. Thus, by engaging male bayonet components with the complementary female bayonet components a watertight connection between manifold **300** and the tub **200** is achieved.

In embodiments according to the present invention, a sacrificial part may be provided as drain-connection element. Preferably, the sacrificial part is formed in correspondence of at least one free end of the drain collar **245** of the tub **200** (and possibly a corresponding sacrificial part may be provided on the tub-side wall **315a** of the manifold **300**). For example, the sacrificial part may be advantageously made  
20 integral with the drain collar **245** (and possibly the tub-side wall **315a**) on which is provided (*i.e.*, the sacrificial part is made of the same material and with the same plastic cast). Advantageously, the sacrificial part allows connecting the manifold **300** to the tub **200** by welding. In other words, sacrificial parts are adapted to melt when the manifold **300** is welded to the tub **200** during the manufacturing phase of  
25 the laundry machine **100**. For example, in the case of vibration welding, the free ends of the drain collar **245** and the tub-side wall **315a** the are brought in contact and then a vibrating force and a compressive force are applied to the manifold **300** and/or to the tub **200** with an intensity strong enough to melt the sacrificial part, which after hardening connects in a watertight manner the manifold **300** and the tub **200**.

30 It should be noted that the sacrificial part may be advantageously threaded; in

such a way, the manifold **300** could be connected to the tub **200** either by welding or by screwing.

Turning now jointly to **Figures 5A** and **5B**, they show another manifold **500** of hard material according to the present invention and such manifold **500** mounted  
5 to the tub **200**, respectively.

The manifold **500** differs from the manifold **300** made of hard material previously described in what follows.

The manifold **500** comprises a filter **540**, a drain pump **545** and a set of pump connection elements **550** provided along the border of drain-side aperture **510**. In  
10 addition, substantially at the drain-side aperture **510**, an exhaust port **555** is provided, preferably, laterally on the manifold **500**.

Advantageously, the filter **540** is adapted to be housed within the first hollow portion **505a** of the manifold **500**. The filter **540** is adapted to prevent fluff and/or small foreign bodies incoming from the tub **200** (not shown, for example buttons  
15 detached from laundry being washed, small coins *etc.*) reaching the drain pump **545** positioned downstream (which may experience malfunctions due to such fluff and/or foreign bodies) and/or remaining inside the draining system (which may lead to a clogging of the draining system). A filter front portion **540a** has a shape designed for blocking said fluff and/or foreign bodies. A rear filter portion **540b** is fluidly  
20 connected with the filter front portion **540a** and preferably, although not necessarily, formed integral with the same. Such rear filter portion **540b** is preferably substantially a hollow half-cylinder having a filter port **540c**.

The drain pump **545** preferably comprises an impeller **560** and an actuator **565** (*e.g.*, an electric motor), which is adapted to rotate the impeller **560**. The  
25 impeller **560** is exposed on a contact wall **545a** of the drain pump **545** on which may be preferably provided a circular pump-sealing gasket **570** and a set of through holes **575**.

During a manufacturing phase, the filter **540** is inserted in the first hollow portion **505b** with the filter front portion **540a** that substantially tightly fits the same,  
30 while the rear filter portion **540b** tightly fits the tub-side aperture **515**, and the filter

port **540c** is aligned with the exhaust port **555**.

Subsequently, the drain pump **545** is coupled with the drain-side aperture **510** and then fastened thereto. In the example at issues, each through hole **575** on the contact wall **545a** matches a corresponding pump connection element **550** (such as a threaded cavity), and the drain pump **545** is fastened to the first hollow portion **505b** by means pump fastening elements, such as pump screws **580**, each of which is inserted into the respective through hole **575** and screwed to the corresponding pump connection element **550**.

Therefore, the contact wall **545a** of the drain pump **545** closes the drain-side aperture **510** of the manifold **500**. The contact wall **545a** and the rear filter portion **540b** result watertight connected, and thanks to the pump-sealing gasket **570**, define a watertight impeller chamber **585** housing the impeller **560** of the drain pump **545**.

Finally, a drain hose (not shown in the figures) is connected to the exhaust port **555** (in any known manner) for the connection with the rest of the draining system.

In operation, waste liquid drained from the tub **200** is collected in the second hollow portion **505a** of the manifold **500**, filtered by the filter **540** and passed in the impeller chamber **585**. Hence, the waste liquid is propelled by the impeller **560** into the exhaust port **555** and therefrom into the drain hose for being discharged or recirculated.

It should be noted that also the manifold **500** may be adapted to be connected to the tub **200** with any of the various drain-connection elements previously described with reference to the manifold **300**.

Considering jointly **Figures 6A** and **6B**, they show another typology of discharge duct, a flexible hose **600** and such flexible hose **600** mounted to the tub **200**, respectively.

In detail, the flexible hose **600** is made of an elastomeric material (such as a synthetic rubber), which comprises a hose portion **605a** and a main hollow portion **605b** preferably having a substantially hemispherical shape, fluidly connected one another.

The hose portion **605a** preferably protrudes substantially laterally from the hemispherical portion **605b**. Both the main portion **605b** and the hose portion **605a** may be formed in a single piece (*e.g.*, may be produced in a single cast) or the flexible hose **600** may be formed by a connection of a distinct main portion **605b** and  
5 hose portion **605a**.

A circular drain-side aperture **610** is provided at a free end of the hose portion **605a**, which is adapted to be engaged with the pump assembly (not shown).

Advantageously, although not limitatively, the hose portion **605a** may comprise a drain bellows **615** adapted to dampen vibrations induced by the suction  
10 action of a drain pump (not shown in the figures) possibly provided downstream the flexible hose **600** in the draining system and/or vibrations of the tub **200** induced by the rotation of the drum **110** during operation.

At a free end of the main portion **605b**, a circular tub-side aperture **620** is provided. Preferably, although not limitatively, the tub-side aperture **620** comprises  
15 a tub-side wall **620a** on an outer side of which one or more seat for housing a fastening element are provided. In the example at issue, couple of protruding ribs **625** define a track **630** adapted to house a clamp member **635** (as described in the following).

Advantageously, although not limitatively, the main portion **605b** may be  
20 advantageously adapted to house a valve member (not shown in the figures) for separating the cool waste liquid collected in the flexible hose **600** from the warm washing liquid contained in the tub **200** during the laundry machine **100** operation, as previously stated.

In the example at issue, the drain collar **245** is inserted into the tub-side  
25 aperture **620**, since the former has a diameter smaller than the diameter of the latter (although other embodiments in which the drain collar **245** has a diameter larger than, or substantially equal to, the tub-side aperture **620** are not excluded). Advantageously, the drain collar **245** is inserted into the tub-side aperture **620** until the free end of the drain collar **245** abuts an upper portion of the sealing gasket,  
30 and/or until the tub-side aperture **620** has completely surrounded the collar band

**245a.**

In order to fasten the flexible hose **600** to the tub **200** the clamp member **635** (*e.g.*, a hose clamp) may be provided. In the example at issue, the clamp member **635** comprises an open-ring element **640** (*e.g.*, such as a circular stripe made of metal  
5 or plastic) and a tightening element, such as a bolt **645**. In its turn, the open-ring element **635a** comprises engagement members **640a** (such as a pair of small threaded rings) at each one of its ends to which the bolt **645** may be coupled. It should be noted that other clamp members, such as cable ties, may be used as well.

During the laundry machine **100** manufacturing phase, the clamp member **635**  
10 is placed around the tub-side wall **620a**, preferably housed in one of the tracks **630** provided thereon. Then, the clamp member **635** is fastened against the tub-side wall **620a** (while the latter encircles the collar band **245a**) by screwing the bolt **645** to the engagement members **640a**, which are thus brought close to each other. Once fastened, the tub-side wall **620a** results firmly coupled with the drain collar **245** in  
15 watertight manner. In other words, the tub-side wall **620a** is substantially caught in a vice-like grip between the collar band **245a** and the fastened clamp member **635**.

Thanks to the solution according to an embodiment of the present invention, it is thus possible to properly perform the connection between the same tub **200** and discharge ducts belonging to different types, such as the manifolds **300** and **500** or  
20 the flexible hose **600**, even if the discharge ducts **300**, **500** and **600** require different fastening elements and/or procedures. Consequently, also the manufacturing planning complexity is substantially lowered, since is no longer needed to match a particular discharge duct type with a corresponding tub type, thus improving the manufacturing yield while lowering the manufacturing costs.

CLAIMS

1. A laundry machine (**100**) for treating laundry comprising a tub (**200**),  
said tub (**200**) comprising:

- 5           - a discharge hole (**240**) for draining liquid out of the tub (**200**),  
          - a plurality of drain-connection elements (**245a, 250a, 250b, 250c, 250d**),  
          said laundry machine (**100**) further comprising a discharge duct (**300; 500; 600**) fluidly connected to the discharge hole (**240**) for collecting liquid drained from the tub (**200**), and fixed to said tub by at least one of said drain-connection elements  
10 (**245a, 250a, 250b, 250c, 250d**),

**characterized in that**

          said plurality of drain-connection elements (**245a, 250a, 250b, 250c, 250d**) comprises at least two different types of drain-connection elements (**245a, 250a, 250b, 250c, 250d**), each one adapted for fixing a corresponding type of discharge  
15 duct to said tub (**200**) by means of a corresponding connection arrangement.

2. The laundry machine (**100**) according to claim 1, wherein

          at least one type of said at least two different types of drain-connection elements (**250a, 250b, 250c, 250d**) comprises one or more drain-connection elements  
20 (**250a, 250b, 250c, 250d**) protruding from the tub (**200**) and wherein

          the discharge duct (**300; 500**) further comprises one or more matching portions (**335a, 335b, 335c, 335d**) matching a corresponding one of said one or more drain-connection elements (**250a, 250b, 250c, 250d**) protruding from the tub (**200**).

25           3. The laundry machine (**100**) according to claim 3, wherein at least one of said one or more drain-connection elements (**250a, 250b, 250c, 250d**) protruding from the tub (**200**) is fixed to a corresponding matching portions (**335a, 335b, 335c, 335d**) of said discharge duct (**300; 500**) by a fastening element (**405**).

30           4. The laundry machine (**100**) according to claim 2 or 3, wherein at least one

drain-connection element (250d) of said one or more drain-connection elements (250a, 250b, 250c, 250d) protruding from the tub (200) and a corresponding matching portion (335d) of said discharge duct (300; 500) are transversal with respect to other drain-connection elements (250a, 250b, 250c) and other matching portions (335a, 335b, 335c), respectively.

5  
10  
15  
20  
25  
30

5. The laundry machine (100) according to claim 3 or to claim 4 when depending on claim 3, wherein at least one of said one or more drain-connection element (250a, 250b, 250c, 250d) protruding from the tub (200) comprises a hollow appendage (250a, 250b, 250c, 250d) adapted to engage with the at least one respective fastening element (405).

6. The laundry machine (100) according to claim 5, wherein at least one matching portion (335a, 335b, 335c, 335d) of the one or more matching portions (335a, 335b, 335c, 335d) comprises a through-hole adapted to the insertion of the at least one respective fastening element (405).

7. The laundry machine (100) according to any one of the preceding claims 1 to 6, further comprising a drain collar (245) protruding outwardly from the tub (200) at a periphery of the discharge hole (240).

8. The laundry machine (100) according to claims 7, wherein the discharge duct (300; 500; 600) comprises a wall (315a; 515a; 620a) adapted to encircle or to be encircled by a predetermined portion (245a) of the drain collar (245).

9. The laundry machine (100) according claim 7 or 8, wherein at least one drain-connection element (245a) of said at least two different types of drain-connection elements (245a, 250a, 250b, 250c, 250d) is provided on the drain collar (245).

10. The laundry machine (100) according to claim 9, wherein said at least one drain-connection element (245a) provided on the drain collar (245) comprises a threaded portion or bayonet elements provided on said drain collar (245) and adapted to engage with a complementary threaded portion or bayonet element provided on  
5 said discharge duct (300; 500; 600).

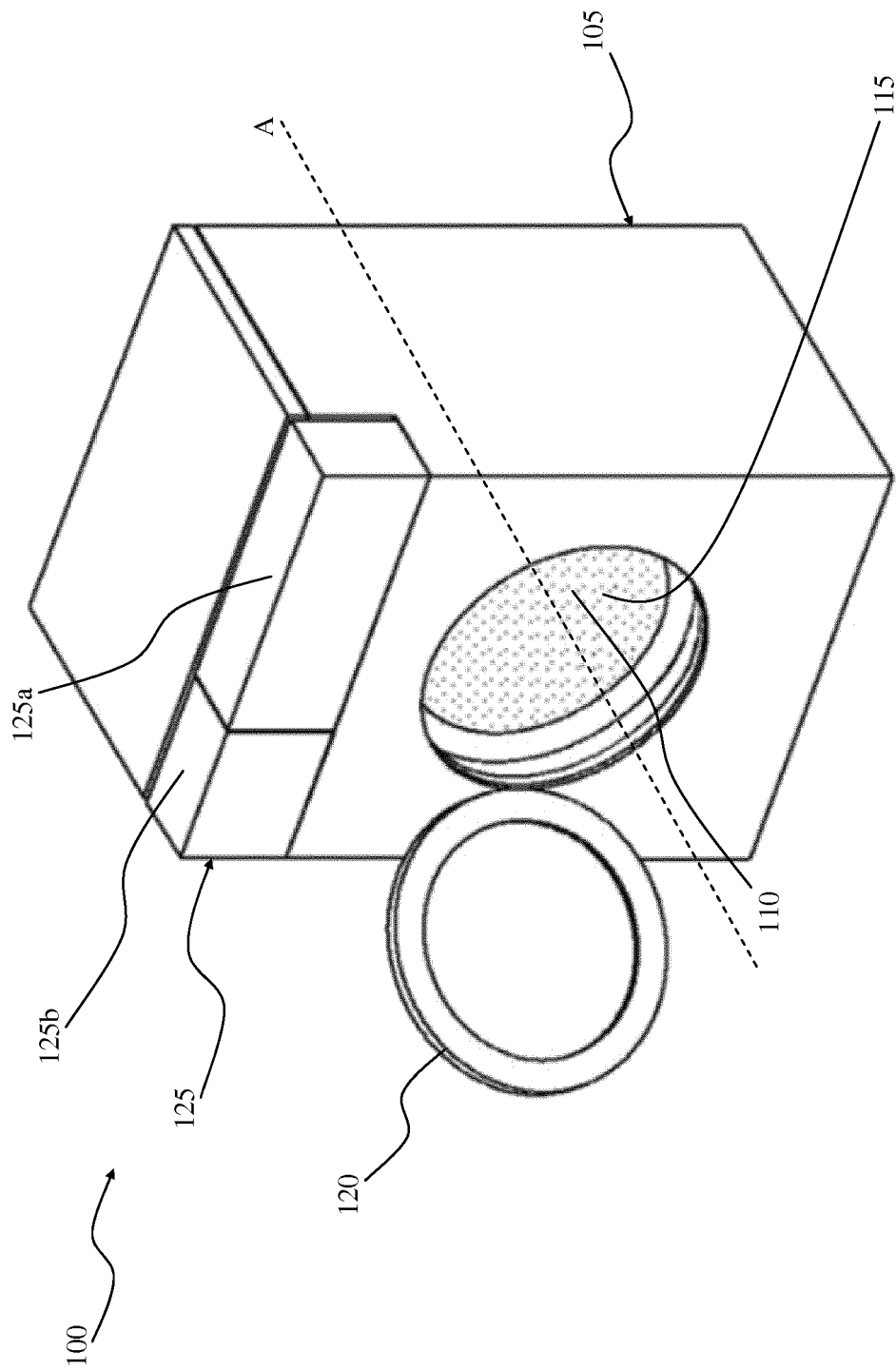
11. The laundry machine (100) according to claim 9 or 10, wherein said at least one drain-connection element (245a) provided on the drain collar (245) comprises a sacrificial part provided on the drain collar (245) and adapted to be used  
10 for welding the discharge duct (300; 500) to the tub (200).

12. The laundry machine (100) according to claim 8, wherein on an external side of said wall (620a) of the discharge duct (600) at least a seat (630) adapted to house at least one clamp member (635) is provided, and  
15 wherein said clamp member (635) is adapted to tighten said wall (620a) against said at least one drain-connection element (245a) provided on the drain collar (245).

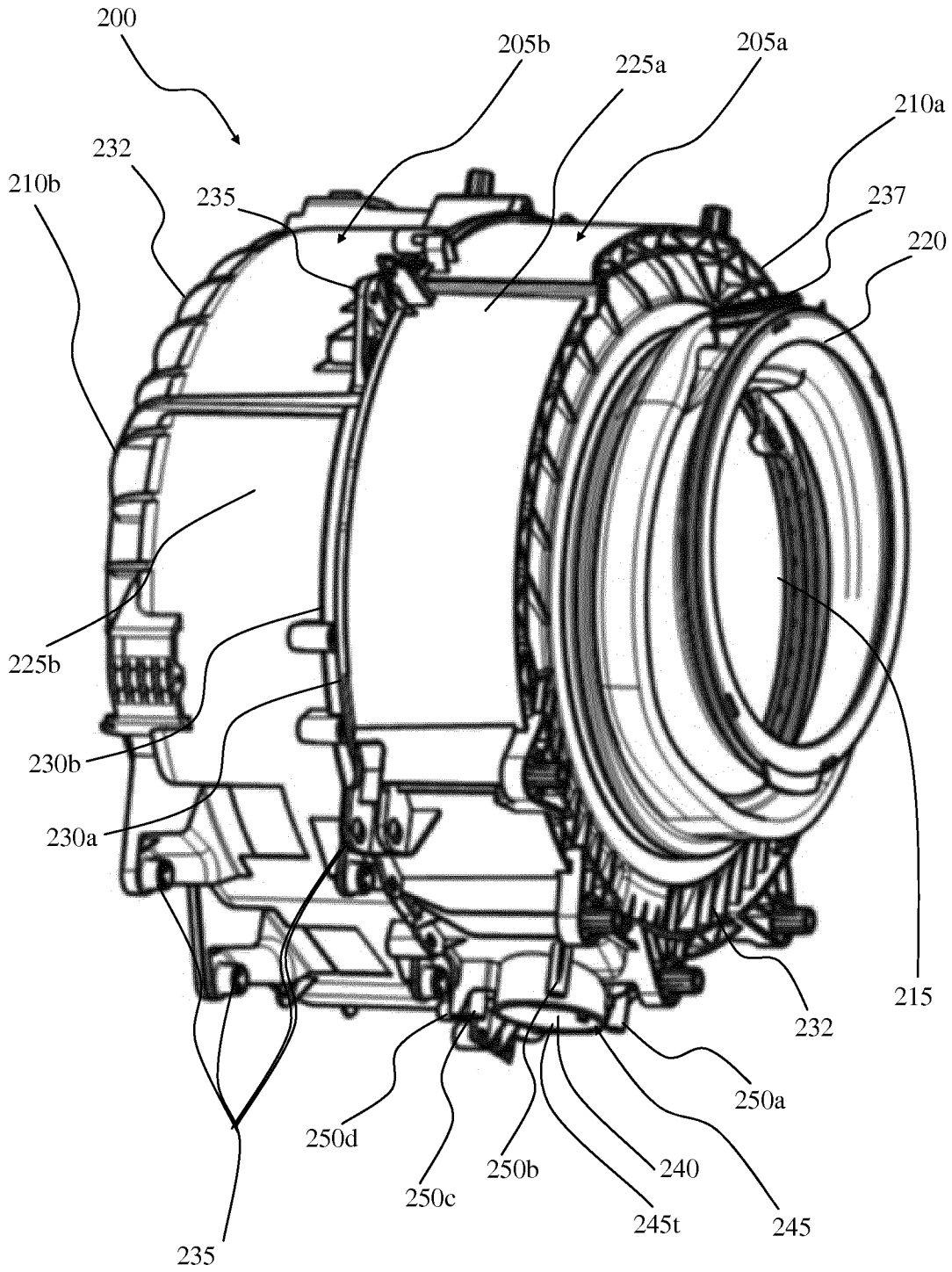
13. The laundry machine (100) according to any of the preceding claims 1 to  
20 11, wherein the discharge duct (300; 500) is made of a hard polymer.

14. The laundry machine (100) according to claim 12, wherein the discharge duct (600) is made of an elastomeric material.

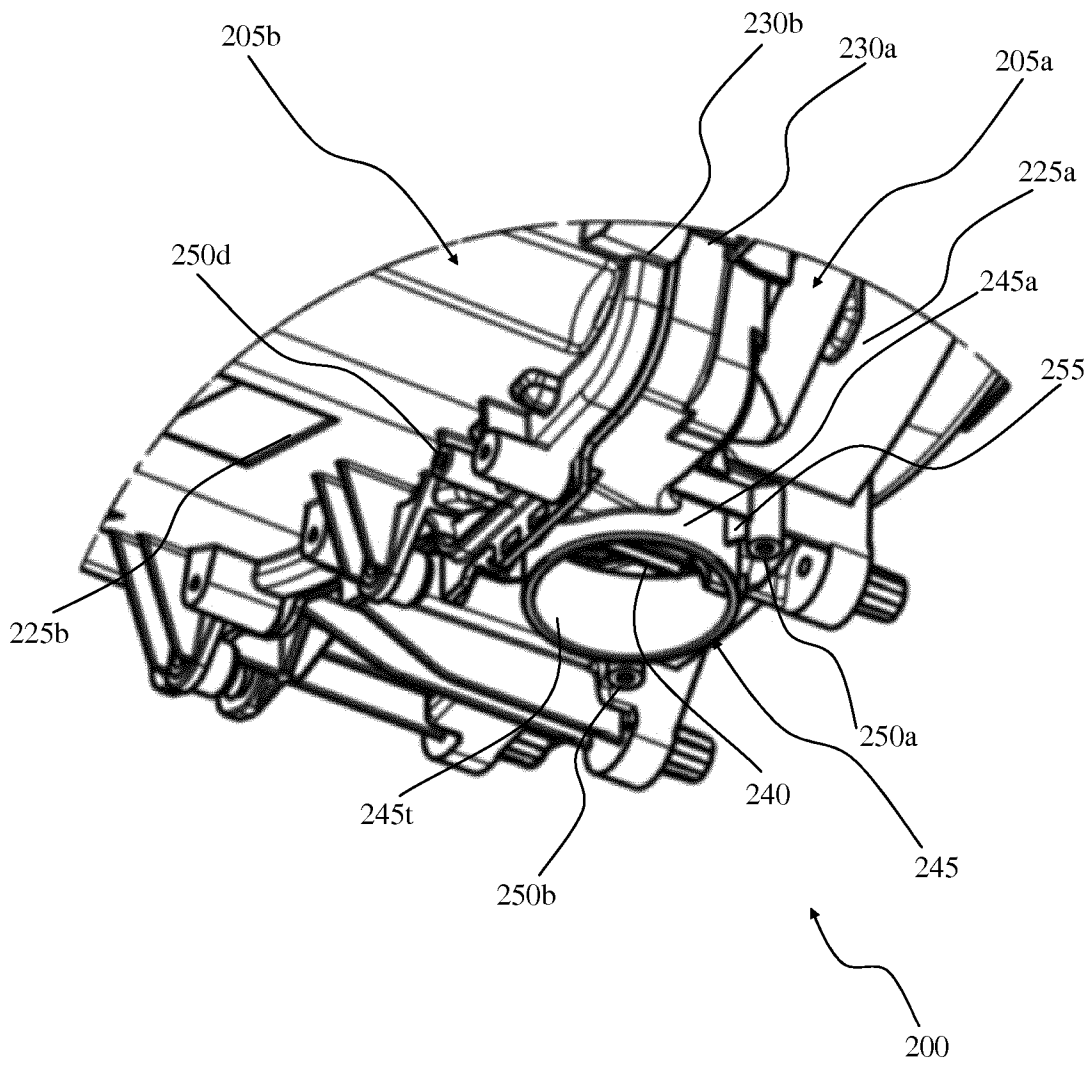




**FIG. 1**

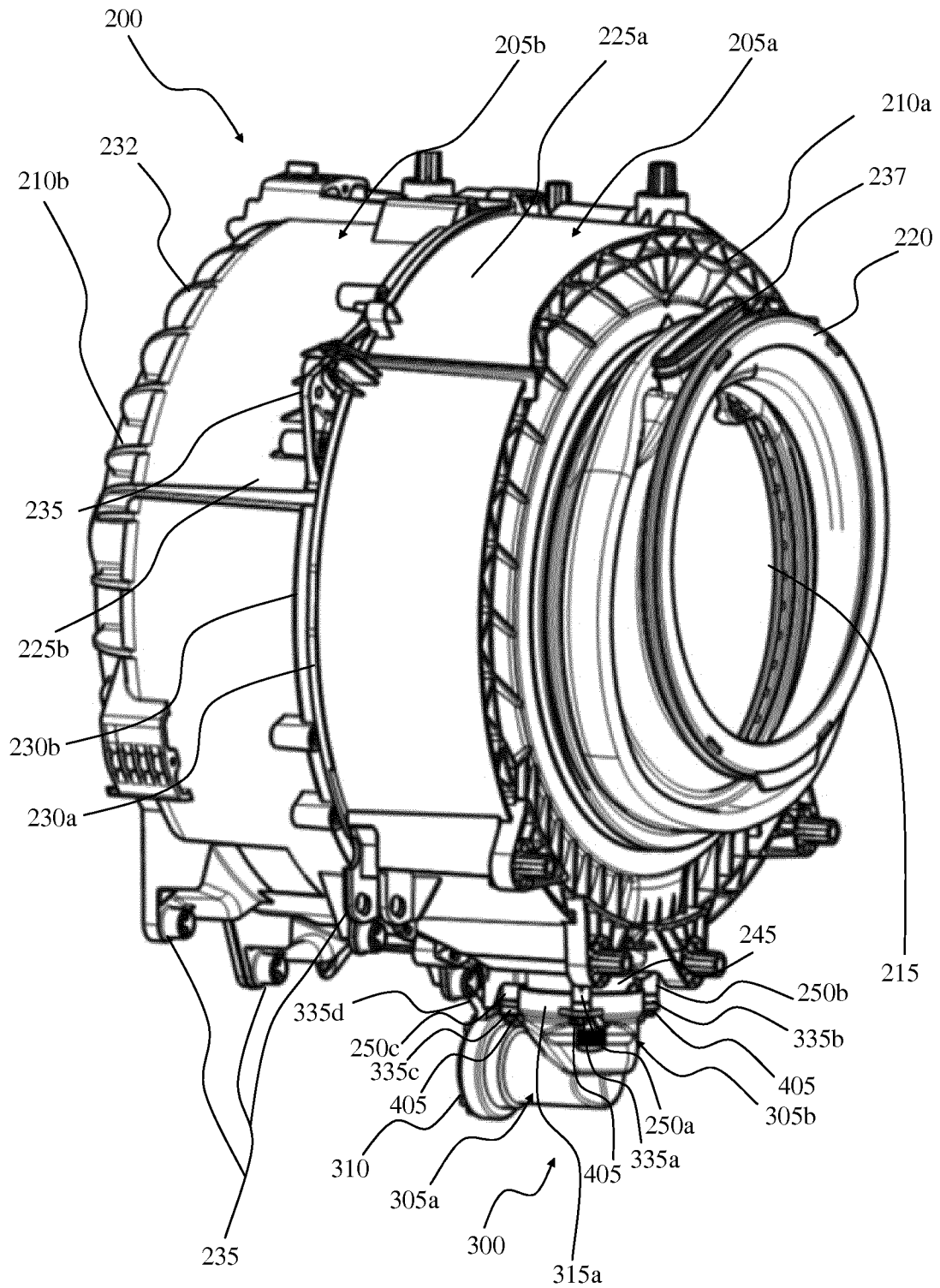


**FIG.2A**

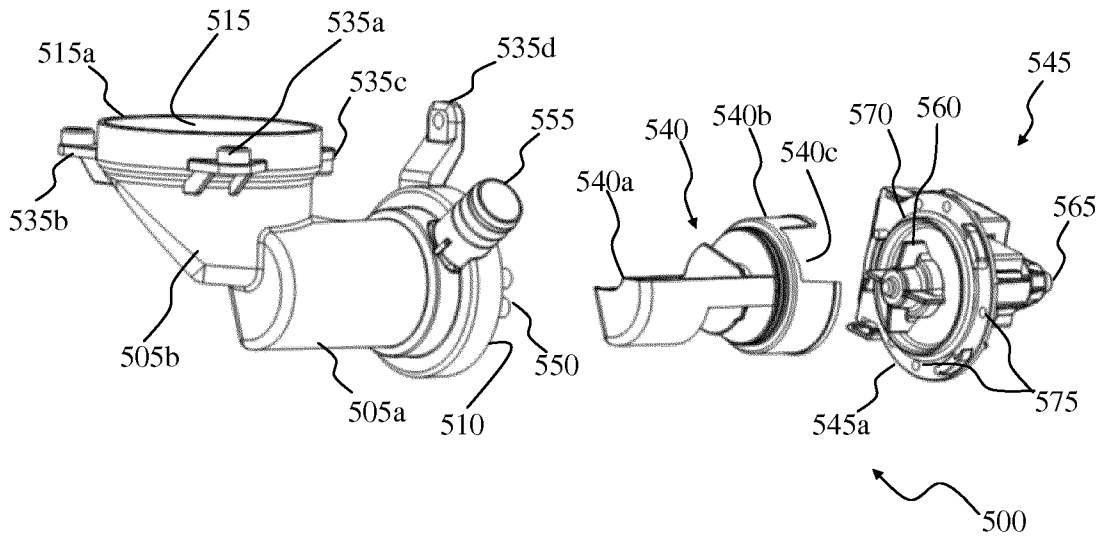


**FIG.2B**

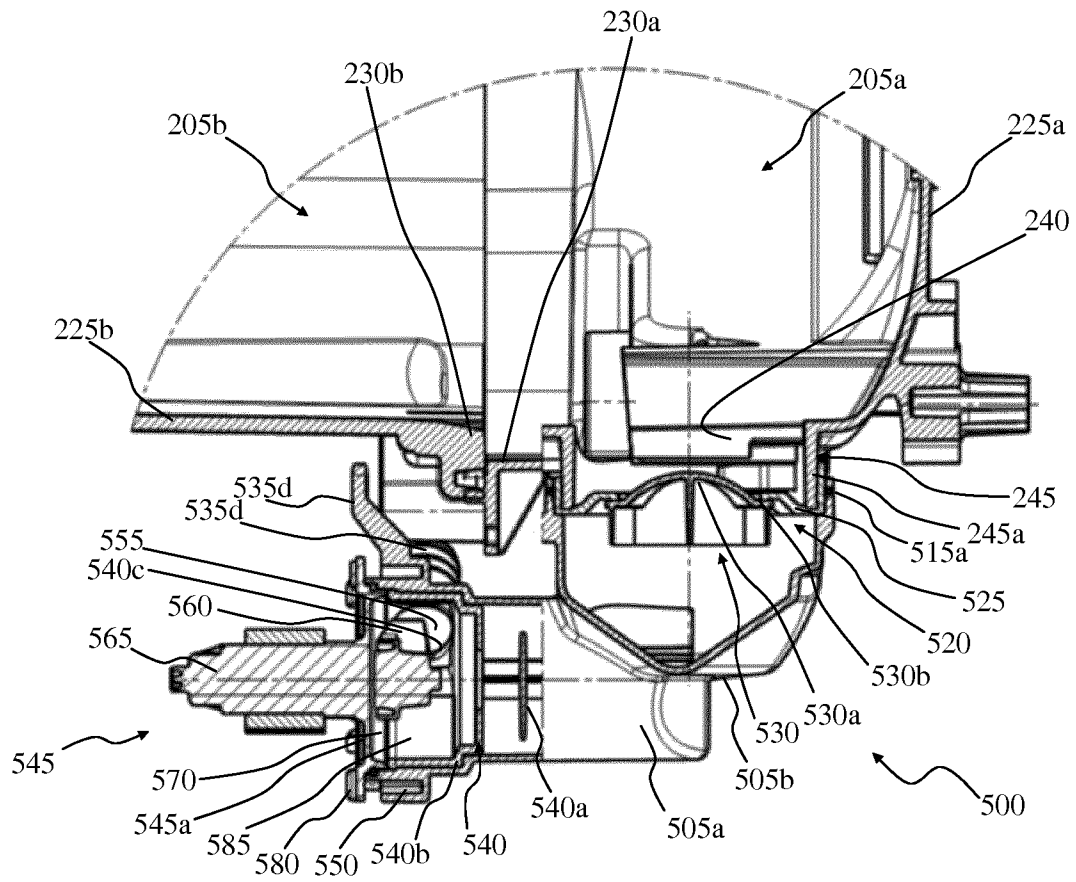




**FIG.4B**



**FIG. 5A**



**FIG. 5B**

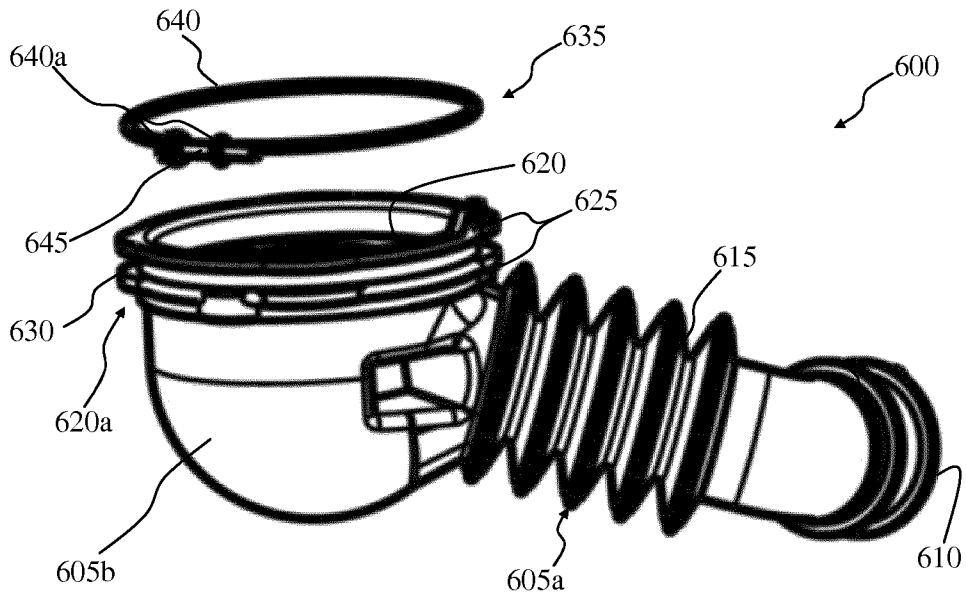


FIG.6A

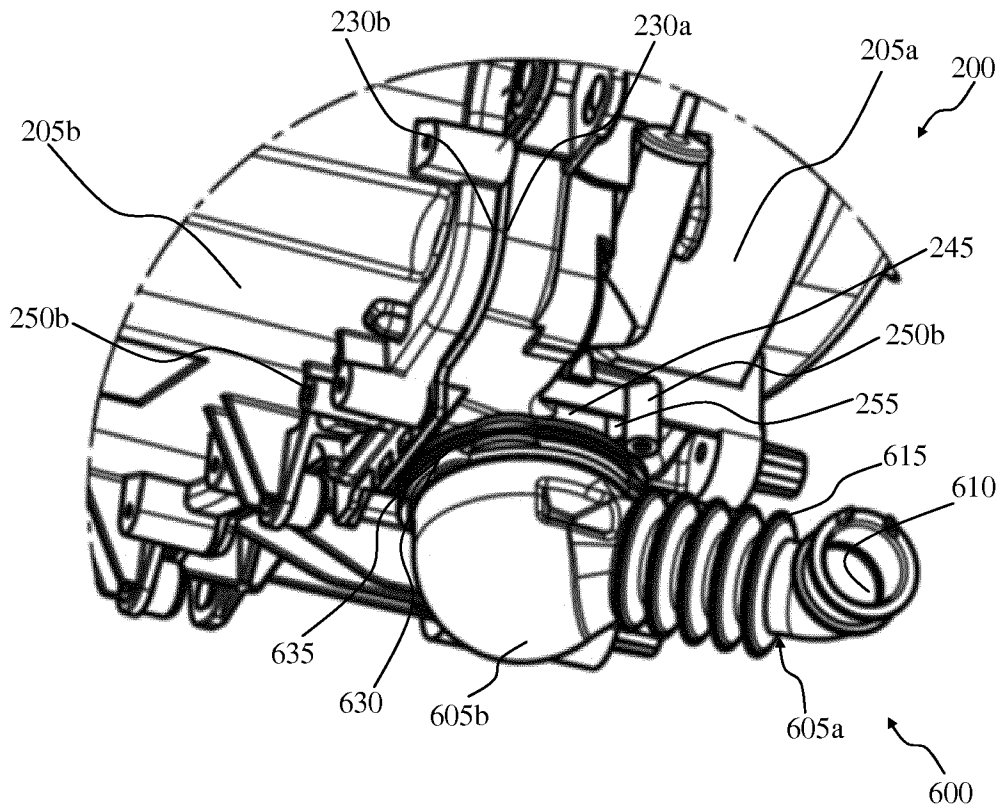


FIG.6B

INTERNATIONAL SEARCH REPORT

International application No  
PCT/EP2013/076622

A. CLASSIFICATION OF SUBJECT MATTER  
INV. D06F37/26 D06F39/08  
ADD.  
According to International Patent Classification (IPC) or to both national classification and IPC

B. FIELDS SEARCHED  
Minimum documentation searched (classification system followed by classification symbols)  
D06F  
Documentation searched other than minimum documentation to the extent that such documents are included in the fields searched

Electronic data base consulted during the international search (name of data base and, where practicable, search terms used)  
EPO-Internal

C. DOCUMENTS CONSIDERED TO BE RELEVANT		
Category*	Citation of document, with indication, where appropriate, of the relevant passages	Relevant to claim No.
X Y A	EP 1 746 193 A1 (COPRECITEC SL [ES]) 24 January 2007 (2007-01-24) paragraph [0012] - paragraph [0018]; figures 1-4 -----	1-3,5-9, 13 11,12,14 4
X	US 2004/244438 A1 (NORTH JOHN HERBERT [GB]) 9 December 2004 (2004-12-09) paragraph [0074] - paragraph [0096]; figures 1,4,7 -----	1,7,9,10
Y	WO 2007/115894 A1 (BSH BOSCH SIEMENS HAUSGERAETE [DE]; GRACIA BOBED ISMAEL [ES]; BORQUE M) 18 October 2007 (2007-10-18) page 4, line 23 - page 5, line 28; figure 4 ----- -/--	11

Further documents are listed in the continuation of Box C.

See patent family annex.

\* Special categories of cited documents :

- "A" document defining the general state of the art which is not considered to be of particular relevance
- "E" earlier application or patent but published on or after the international filing date
- "L" document which may throw doubts on priority claim(s) or which is cited to establish the publication date of another citation or other special reason (as specified)
- "O" document referring to an oral disclosure, use, exhibition or other means
- "P" document published prior to the international filing date but later than the priority date claimed

"T" later document published after the international filing date or priority date and not in conflict with the application but cited to understand the principle or theory underlying the invention

"X" document of particular relevance; the claimed invention cannot be considered novel or cannot be considered to involve an inventive step when the document is taken alone

"Y" document of particular relevance; the claimed invention cannot be considered to involve an inventive step when the document is combined with one or more other such documents, such combination being obvious to a person skilled in the art

"&" document member of the same patent family

Date of the actual completion of the international search  23 April 2014	Date of mailing of the international search report  02/05/2014
Name and mailing address of the ISA/ European Patent Office, P.B. 5818 Patentlaan 2 NL - 2280 HV Rijswijk Tel. (+31-70) 340-2040, Fax: (+31-70) 340-3016	Authorized officer  Engelhardt, Helmut



## INTERNATIONAL SEARCH REPORT

International application No  
PCT/EP2013/076622

C(Continuation). DOCUMENTS CONSIDERED TO BE RELEVANT		
Category*	Citation of document, with indication, where appropriate, of the relevant passages	Relevant to claim No.
Y	JP S61 71098 A (TIGERS POLYMER; HITACHI LTD) 11 April 1986 (1986-04-11) figures 1-5 -----	12,14
A	JP S56 176692 U (MATSUSHITA SEAT INDUSTRY CO., LTD) 26 December 1981 (1981-12-26) figures 1-3 -----	1-3,5-9, 13

# INTERNATIONAL SEARCH REPORT

Information on patent family members

International application No

PCT/EP2013/076622

Patent document cited in search report	Publication date	Patent family member(s)	Publication date
EP 1746193	A1	24-01-2007	AT 408725 T 15-10-2008
			EP 1746193 A1 24-01-2007
			ES 2313159 T3 01-03-2009
			US 2007018453 A1 25-01-2007
-----			
US 2004244438	A1	09-12-2004	NONE
-----			
WO 2007115894	A1	18-10-2007	AT 469259 T 15-06-2010
			CN 101426970 A 06-05-2009
			CN 201071461 Y 11-06-2008
			EA 200870428 A1 28-04-2009
			EP 2013399 A1 14-01-2009
			ES 2317730 A1 16-04-2009
			US 2009165506 A1 02-07-2009
			WO 2007115894 A1 18-10-2007
-----			
JP S6171098	A	11-04-1986	JP H0340637 B2 19-06-1991
			JP S6171098 A 11-04-1986
-----			
JP S56176692	U	26-12-1981	NONE
-----			