



US00D755308S

(12) **United States Design Patent**
Hattori

(10) **Patent No.:** **US D755,308 S**

(45) **Date of Patent:** **** May 3, 2016**

(54) **TOY CAR**

(71) Applicant: **EPOCH COMPANY, LTD.**, Tokyo (JP)

(72) Inventor: **Daisuke Hattori**, Tokyo (JP)

(73) Assignee: **EPOCH COMPANY, LTD.**, Tokyo (JP)

(**) Term: **14 Years**

(21) Appl. No.: **29/525,289**

(22) Filed: **Apr. 28, 2015**

(30) **Foreign Application Priority Data**

Dec. 19, 2014 (JP) 2014-028473

(51) **LOC (10) CL.** **21-01**

(52) **U.S. CL.**

USPC **D21/551**

(58) **Field of Classification Search**

USPC D21/533, 548, 549, 550, 551, 561, 562,
D21/433; D12/82, 86, 88, 89, 90, 91, 92,
D12/93; 446/465, 468, 470, 471, 431,
446/454-456

CPC .. B60C 2200/20; B62B 5/0033; A63H 17/26;
A63H 17/262; A63H 17/264; A63H 17/266;
A63H 17/36; A63H 17/38; A63H 29/00;
A63H 29/22; A63H 29/24; A63H 30/04

See application file for complete search history.

(56) **References Cited**

U.S. PATENT DOCUMENTS

D350,086 S *	8/1994	Kong	D12/92
D402,332 S *	12/1998	Fichter	D21/433
D460,791 S *	7/2002	McBride	D12/86
D465,436 S *	11/2002	Dehner	D12/92
D500,000 S *	12/2004	Dyson	D12/92
D536,397 S *	2/2007	Fine	D21/551
D678,962 S *	3/2013	Tsuchiya	D21/551
D732,115 S *	6/2015	Talios	D21/433
D740,374 S *	10/2015	Min	D21/433
D746,382 S *	12/2015	Min	D21/433

* cited by examiner

Primary Examiner — Cynthia M Chin

(74) *Attorney, Agent, or Firm* — Fulwider Patton LLP

(57) **CLAIM**

The ornamental design for a toy car, as shown and described.

DESCRIPTION

FIG. 1 is a front, perspective view of a toy car unit showing my new design;
FIG. 2 is a rear perspective view thereof;
FIG. 3 is a left side elevational view thereof;
FIG. 4 is a right side elevational view thereof;
FIG. 5 is a front elevational view thereof;
FIG. 6 is a rear elevational view thereof;
FIG. 7 is a top plan view thereof;
FIG. 8 is an alternate front perspective view of my new design; and,
FIG. 9 is an alternate rear perspective view of my new design.
The features shown in broken lines with consistent dash lengths illustrate toy car unit ornamentation, features, and/or environment that form no part of the claimed design.

1 Claim, 9 Drawing Sheets

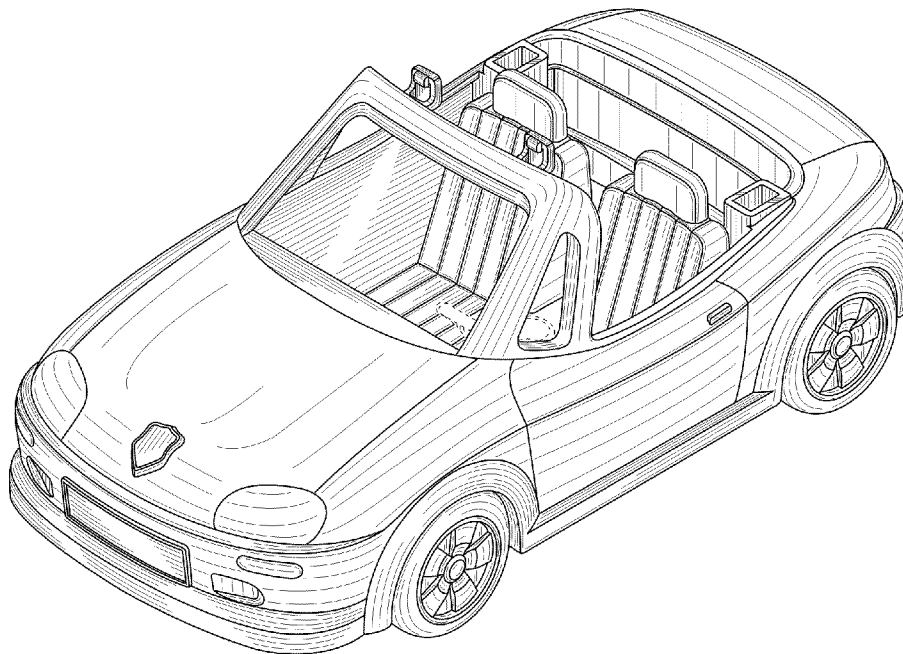

FIG. 1

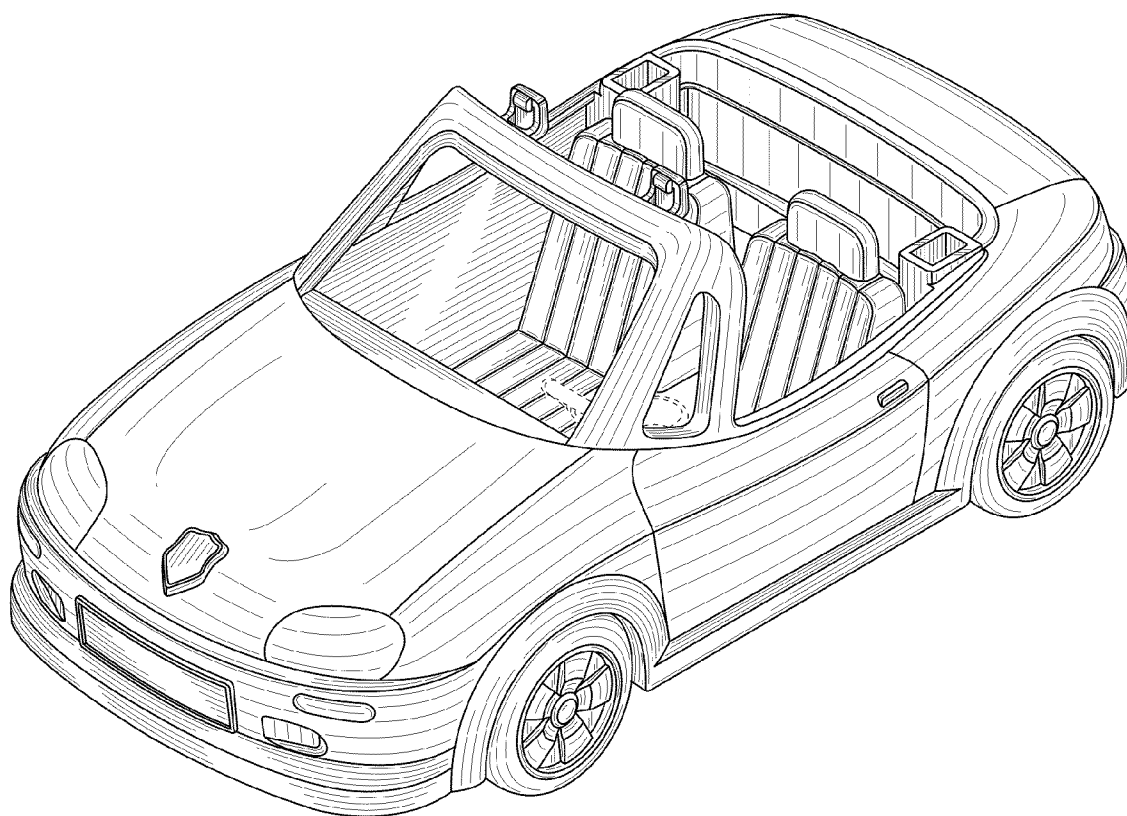

FIG. 2

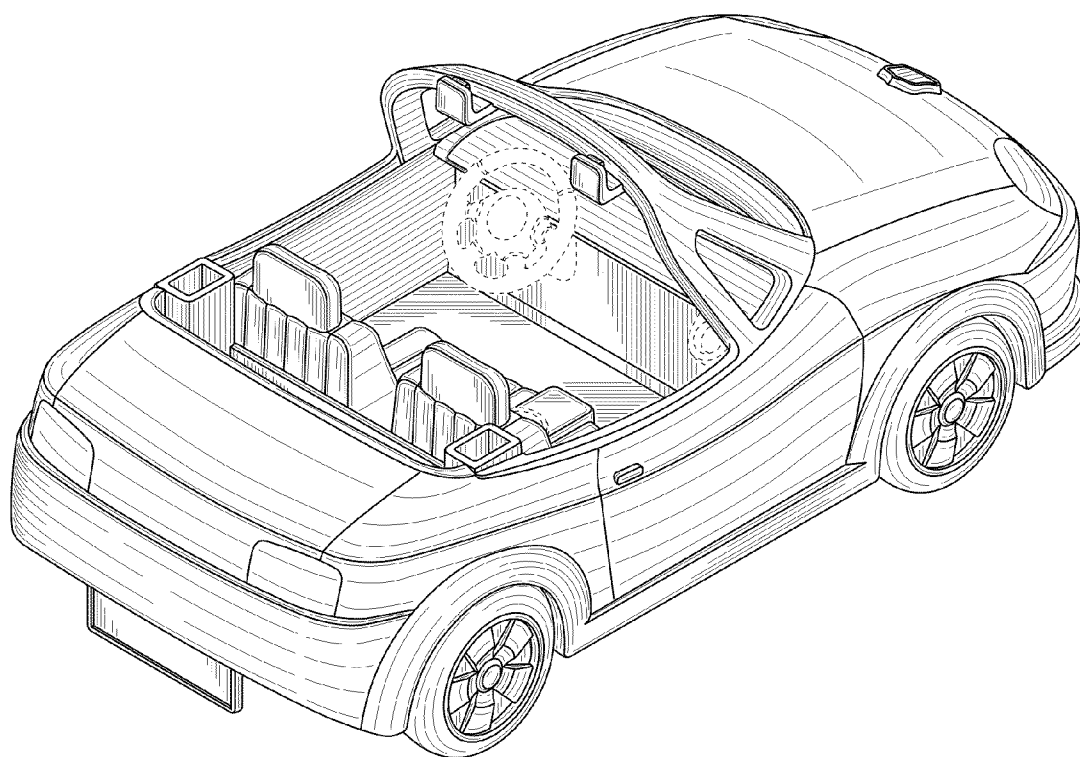

FIG. 3

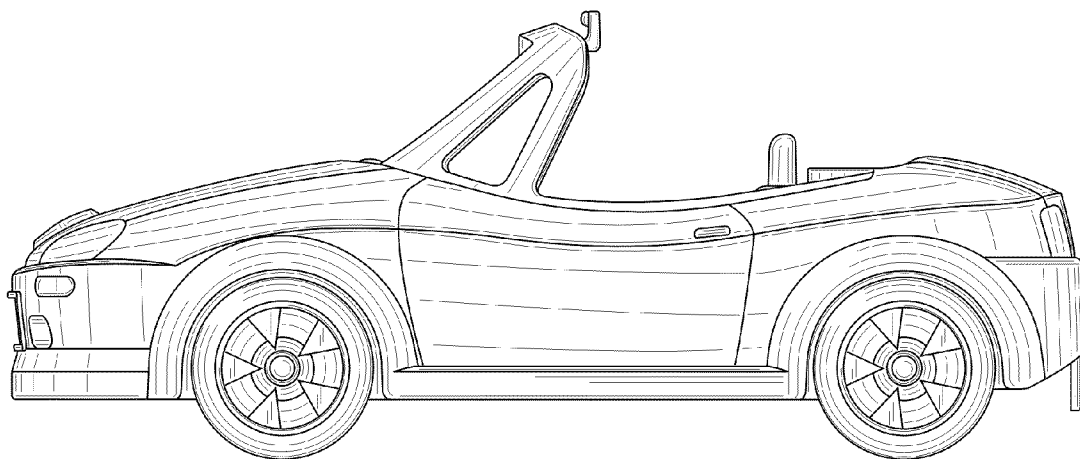

FIG. 4

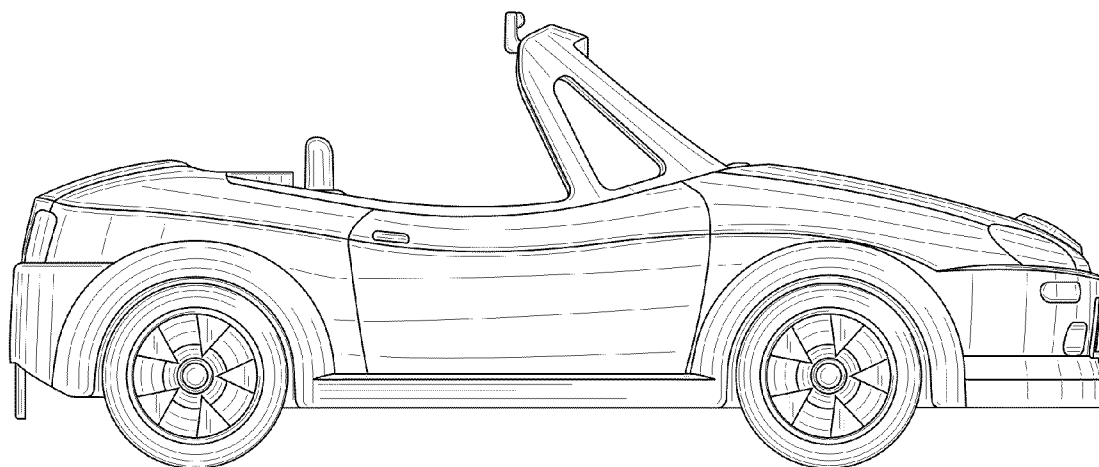

FIG. 5

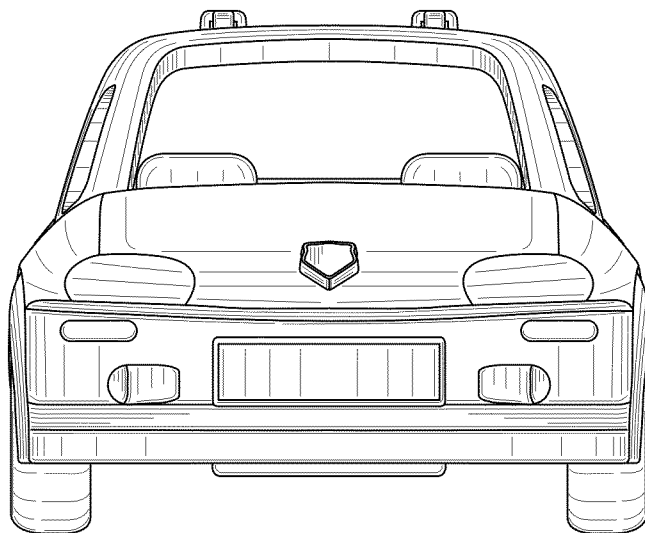

FIG. 6

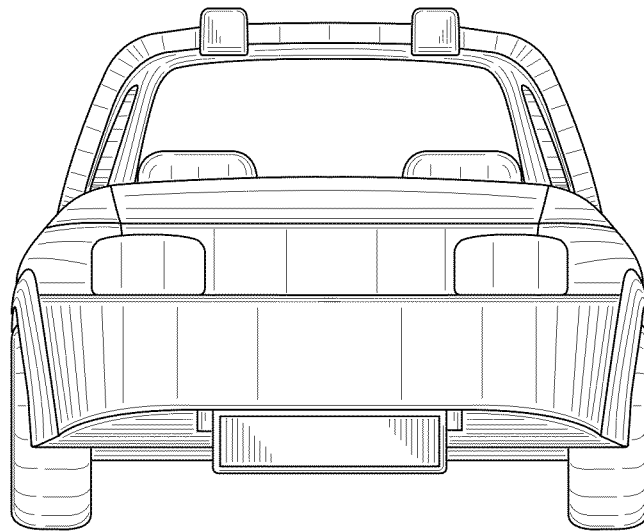

FIG. 7

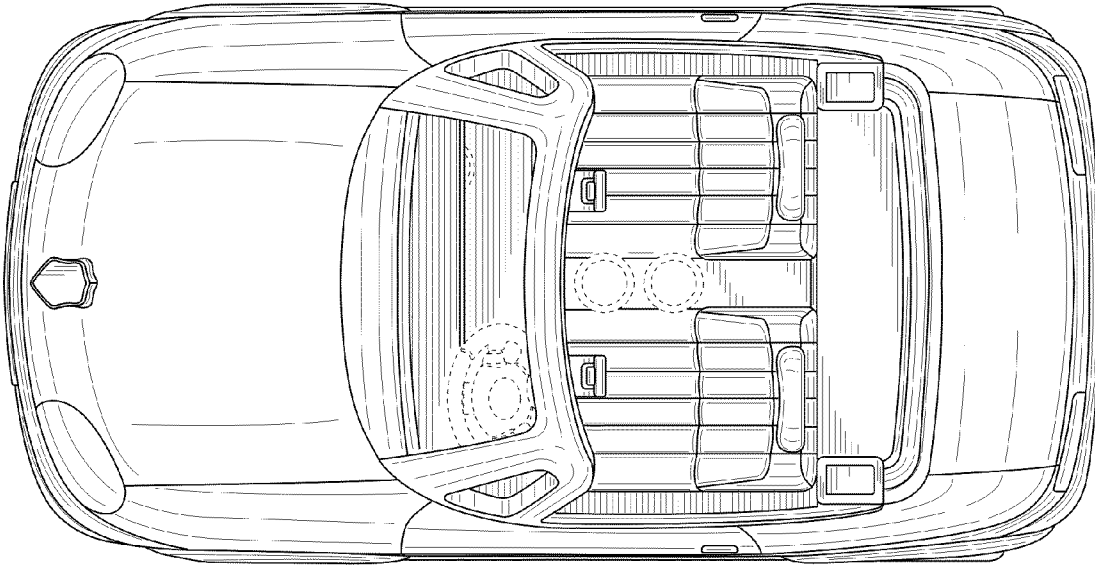

FIG. 8

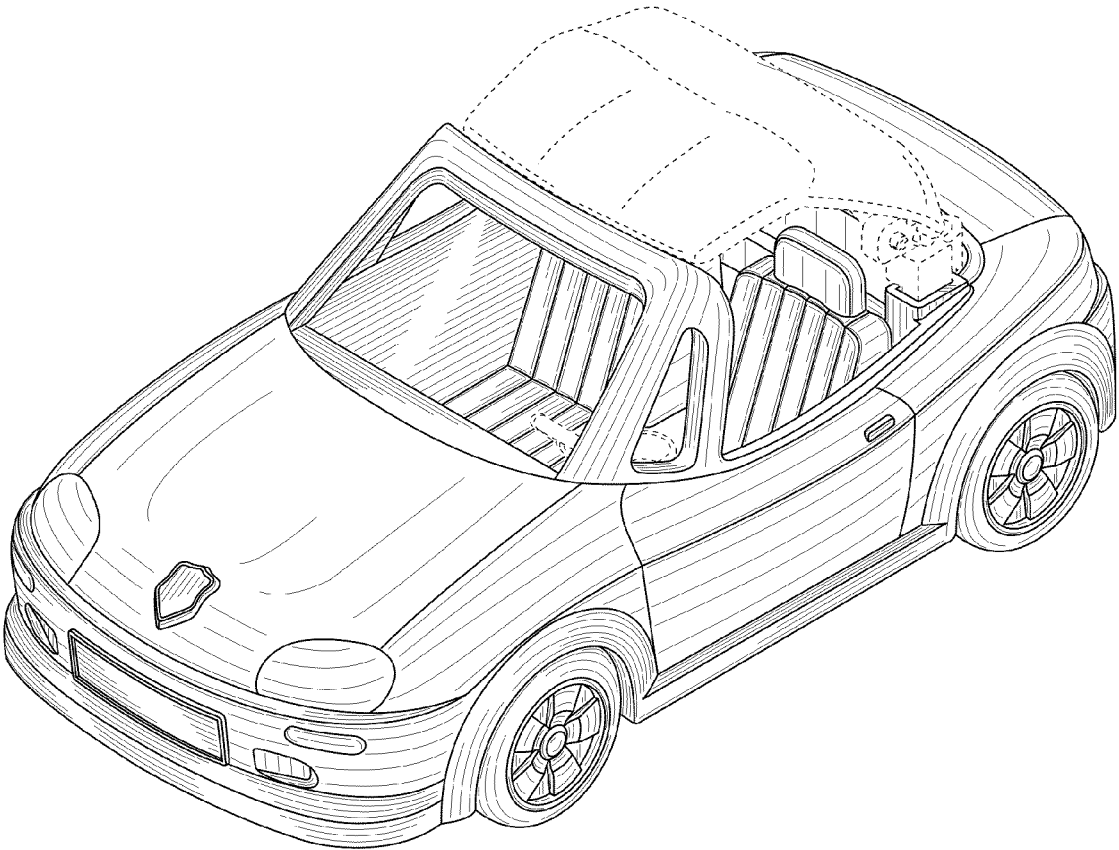

FIG. 9

