

W. T. Flinn,

Let. Off. for Looms.

No. 113415.

Patented Apr. 4, 1871.

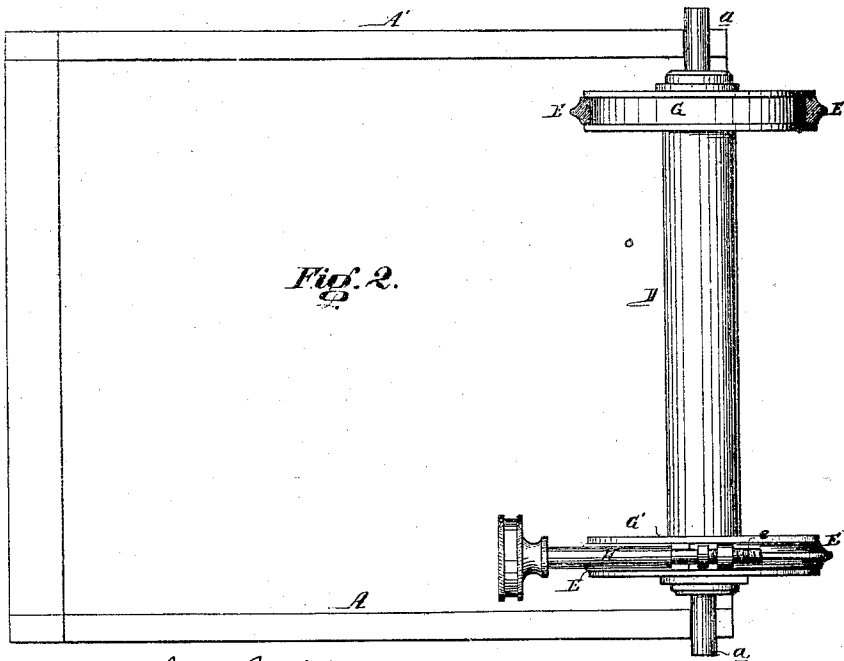
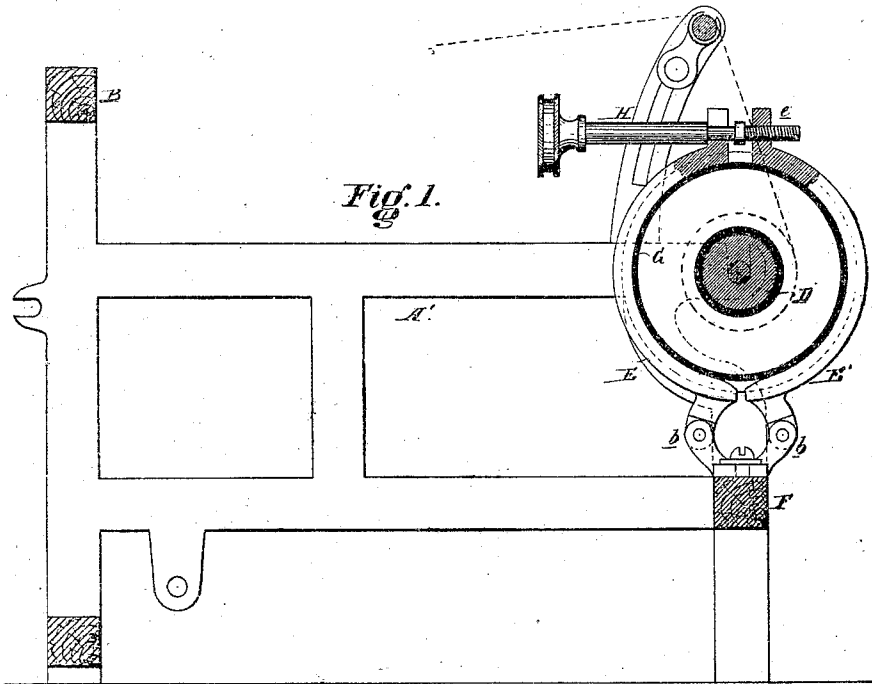

Witnesses

J. B. Harding  
John Tucker

W. T. Flinn  
by his Atty  
Hewson and Son

# UNITED STATES PATENT OFFICE.

WILLIAM THOMAS FLINN, OF PHILADELPHIA, PENNSYLVANIA, ASSIGNOR  
TO HIMSELF AND JACOB STEINMETZ THORN, OF SAME PLACE.

## IMPROVEMENT IN LET-OFF MECHANISMS FOR LOOMS.

Specification forming part of Letters Patent No. **113,415**, dated April 4, 1871.

### *To all whom it may concern:*

Be it known that I, WILLIAM THOMAS FLINN, of Philadelphia, county of Philadelphia, State of Pennsylvania, have invented a Let-Off Device for Looms, of which the following is a specification.

My invention consists of a warp-beam for looms, having its bearings in clamps constructed, as fully described hereinafter, so that more or less friction may be imparted to the beam.

The object of my invention is to maintain a uniform tension on the warp-threads and to regulate the amount of tension at pleasure.

In the accompanying drawings, Figure 1 is a vertical section of sufficient of a loom to illustrate my improvement, and Fig. 2 a plan view of the same.

A and A' represent the opposite side frames of a loom; B, the breast-beam, and D the warp-beam or roller. This warp-beam has the usual journals, *a a*, but these do not revolve in the ordinary bearings in the frame, but in vertical slots, which serve only to retain the beam in a proper lateral position, its vertical support depending on clamps E and E', hinged to brackets *b* on the rear cross-bar of the frame. There are two of these clamps, one adapted to a grooved pulley, G, secured to the beam near one end of the same, and the other to a similar pulley, G', at the opposite end of the beam, each clamp consisting of a segment provided with a lip, *e*. These segments are caused to grip their pulley with more or less force—in the present instance by a rod, H, having a screw-thread adapted to the lip *e* of one segment and arranged to turn freely in the lip of the other segment, the rod being confined longitudinally to this lip by suitable collars, so that on turning the rod in one direction the clamp will be contracted and grip the pulley, and on turning it in the opposite direction the

clamp will be opened, and this opening may be aided by a suitable spring situated between the projections *e* of the segments.

It will be seen that the lower curved end of each segment extends beyond the pin *b* on which the segment is hung, and therefore that the vertical pressure of the beam bearing on these ends of the segments will cause the segments to grasp the pulleys with a pressure corresponding to the weight of the beam, the friction being greatest when the warp-beam is full and heaviest, and when the leverage exerted to turn the beam by the take-up motion is greatest, and the weight, and consequently the friction, decreasing as the warp-threads are drawn off, the leverage, owing to the diminution in the diameter of the beam, becomes less; hence I have termed the device a "compensating let-off device," by which a uniform tension of the warp-threads is maintained.

More or less tension may be readily imparted to the warp-threads by turning the rods H, and thereby causing the clamps to embrace the pulleys with more or less force.

I do not desire to confine myself to the precise arrangement and construction of parts herein described; but

I claim—

The combination of the clamps and the warp-beam resting thereon, the said clamps being constructed, substantially as described, so that the pressure of the beam upon the lower ends of the clamps will cause them to grasp the beam.

In testimony whereof I have signed my name to this specification in the presence of two subscribing witnesses.

W. T. FLINN.

Witnesses:

THOS. McILVAIN,  
HARRY SMITH.