



US 20170157449A1

(19) **United States**

(12) **Patent Application Publication**  
**Giannelli et al.**

(10) **Pub. No.: US 2017/0157449 A1**

(43) **Pub. Date: Jun. 8, 2017**

(54) **ADAPTIVE RESISTANCE EXERTING EXERCISE APPARATUS**

*A63B 21/008* (2006.01)

*A63B 21/02* (2006.01)

*A63B 21/062* (2006.01)

*A63B 21/005* (2006.01)

(71) Applicant: **Cybox International, Inc.**, Medway, MA (US)

(52) **U.S. Cl.**

CPC ..... *A63B 21/156* (2013.01); *A63B 21/063*

(2015.10); *A63B 21/0051* (2013.01); *A63B*

*21/0088* (2013.01); *A63B 21/023* (2013.01);

*A63B 21/4035* (2015.10); *A63B 23/03541*

(2013.01); *A63B 23/0355* (2013.01)

(72) Inventors: **Raymond Giannelli**, Franklin, MA (US); **Mark Buontempo**, Millville, MA (US)

(21) Appl. No.: **15/423,033**

(22) Filed: **Feb. 2, 2017**

(57)

**ABSTRACT**

**Related U.S. Application Data**

An exercise apparatus comprising:

a weight stack,

a flexible elongated cable having a downstream portion that is interconnected to a user selectable number of the one or more individual bodies of weight and to a second resistance device,

a manually movable actuating device interconnected to a proximal end of the cable, a downstream portion of the cable being interconnected to the one or more individual bodies of weight and to the second resistance device in an arrangement that pulls on both the one or more individual bodies of weight and the second resistance device.

(63) Continuation of application No. 14/982,678, filed on Dec. 29, 2015, which is a continuation of application No. PCT/US2014/056206, filed on Sep. 18, 2014.

(60) Provisional application No. 61/879,334, filed on Sep. 18, 2013.

**Publication Classification**

(51) **Int. Cl.**

*A63B 21/00* (2006.01)

*A63B 23/035* (2006.01)

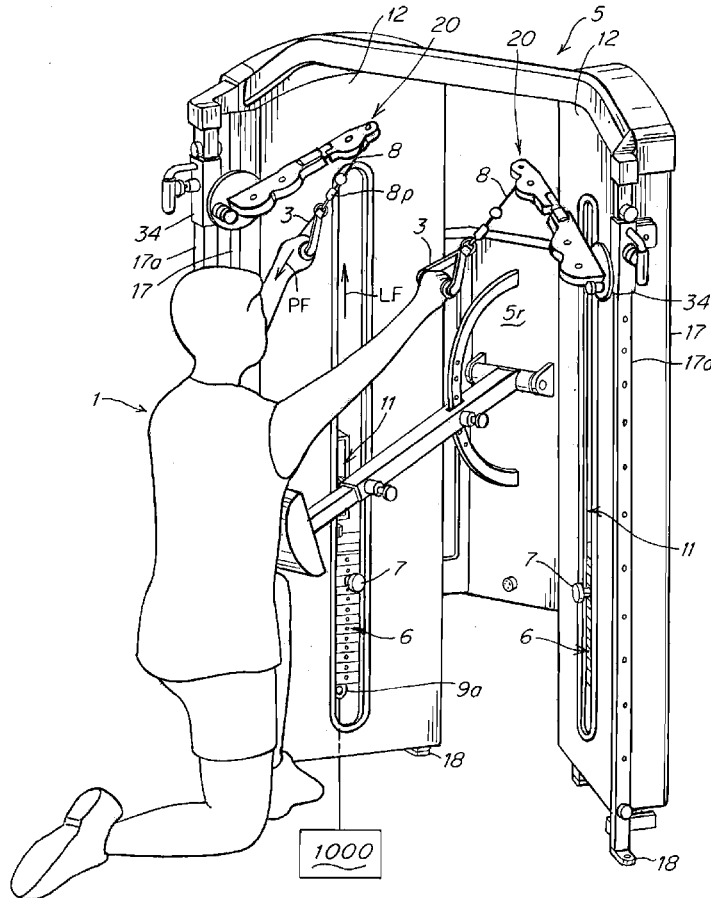

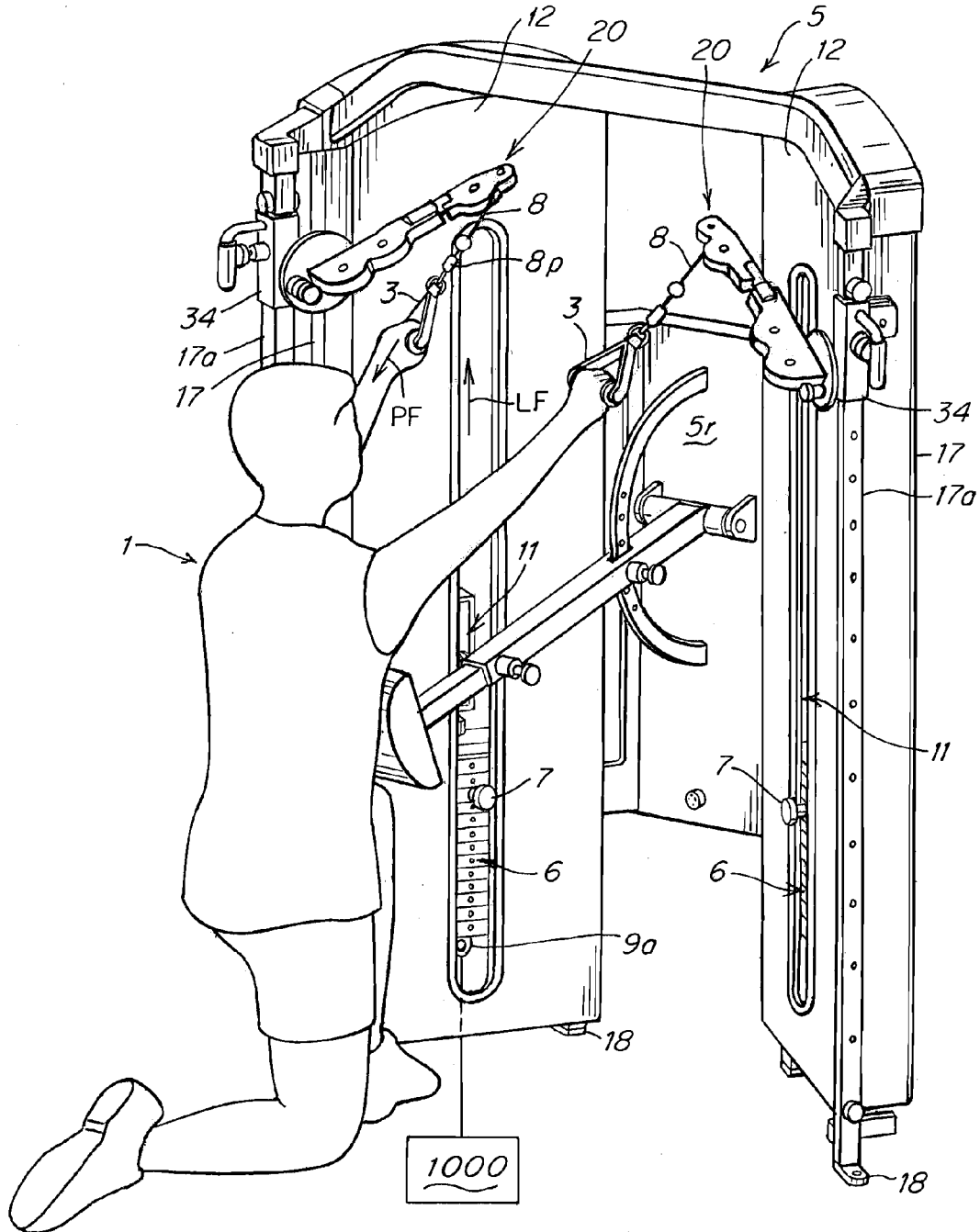

Fig. 1

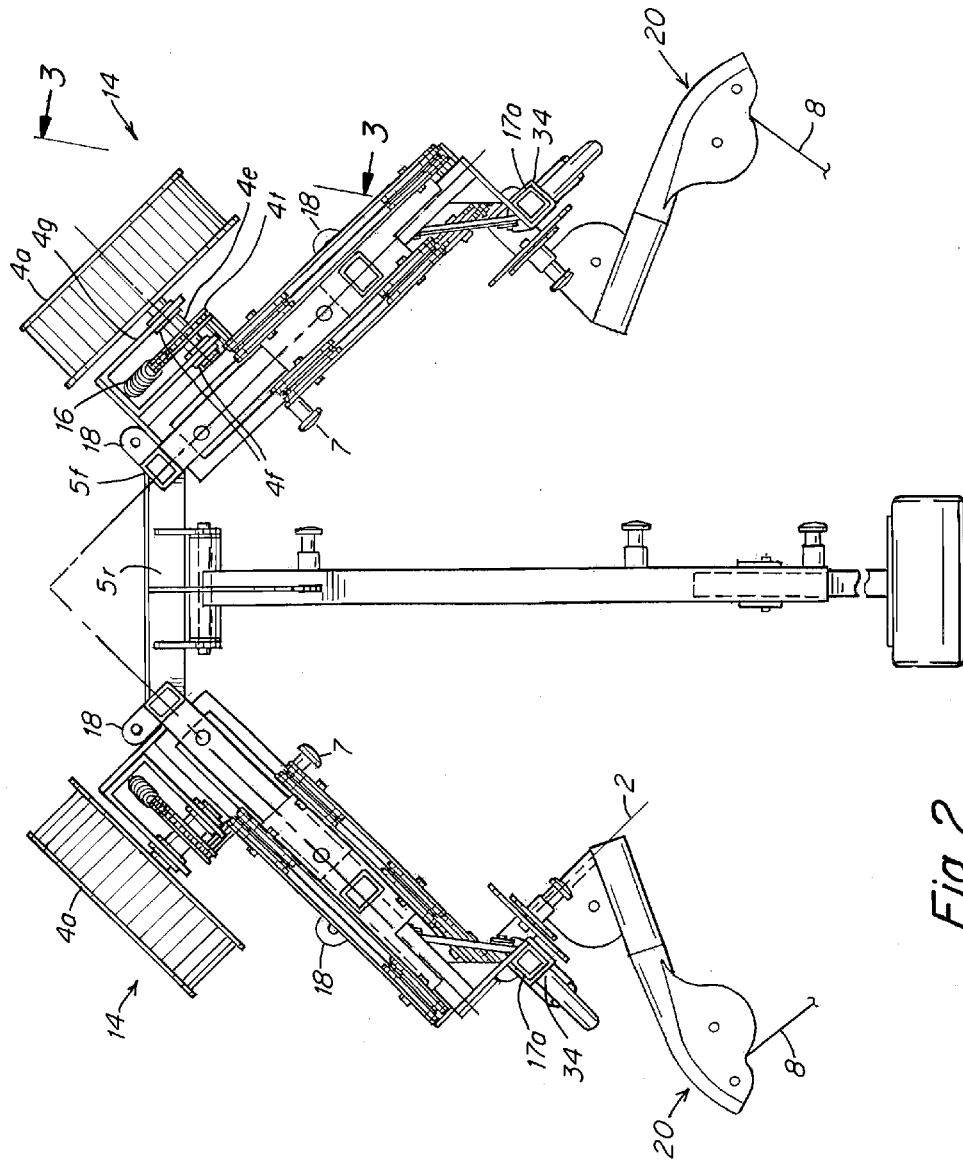

Fig. 2

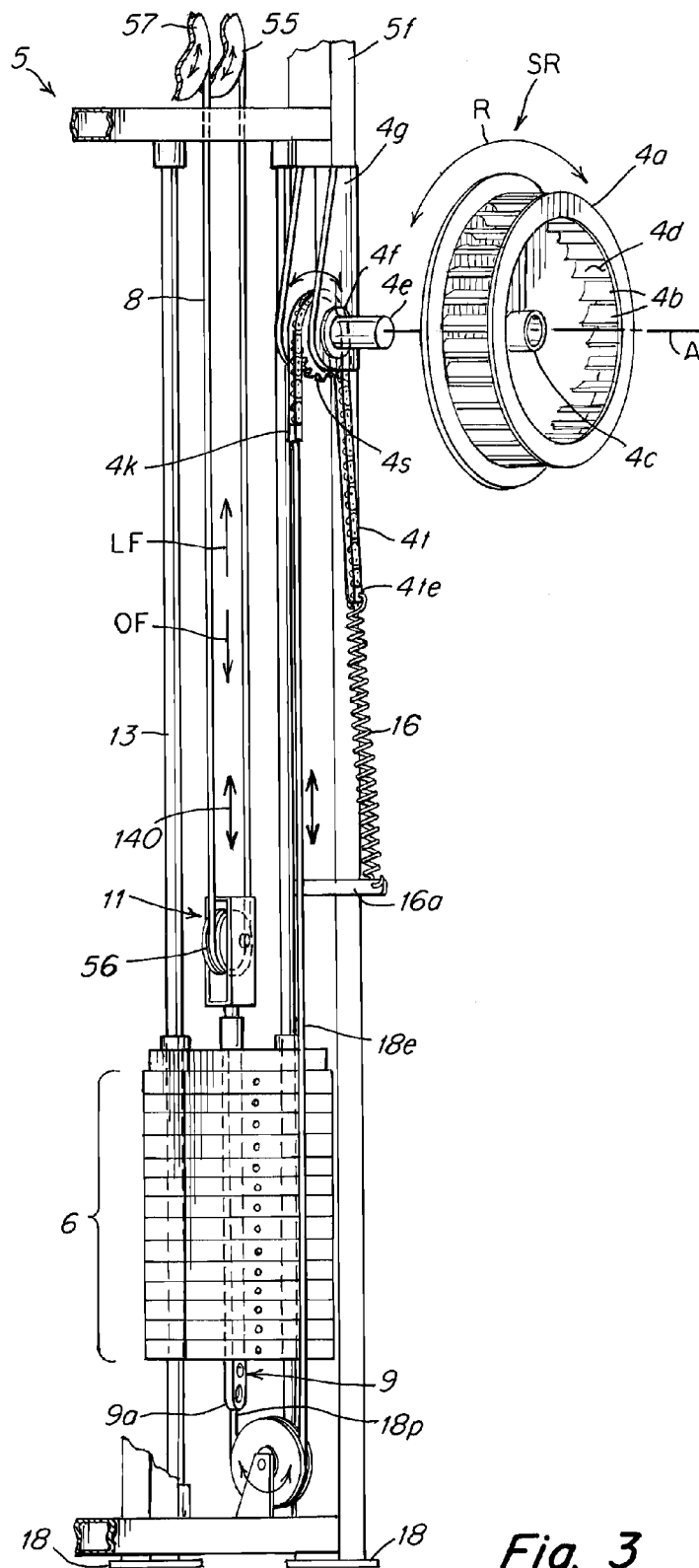
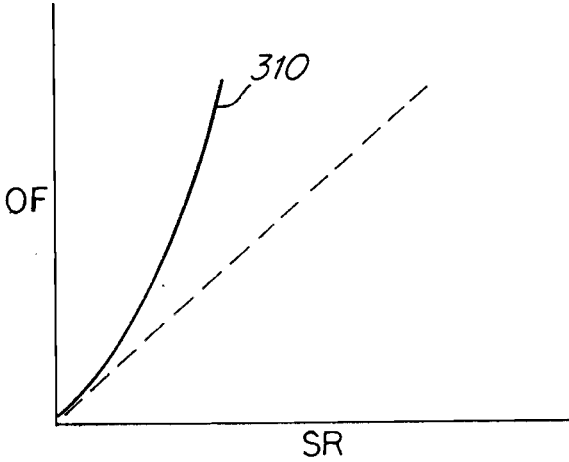

Fig. 3



*Fig. 3A*

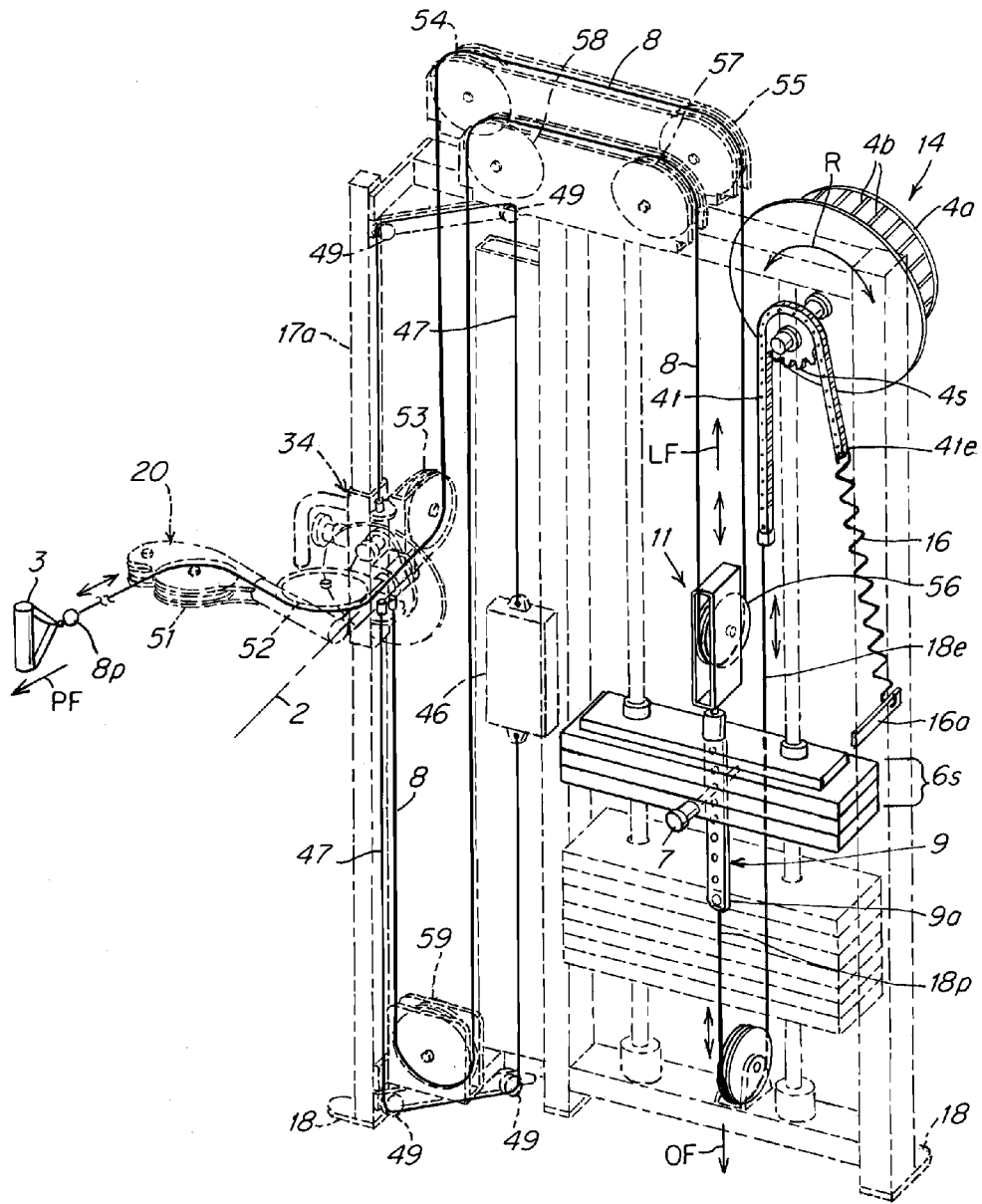

Fig. 4

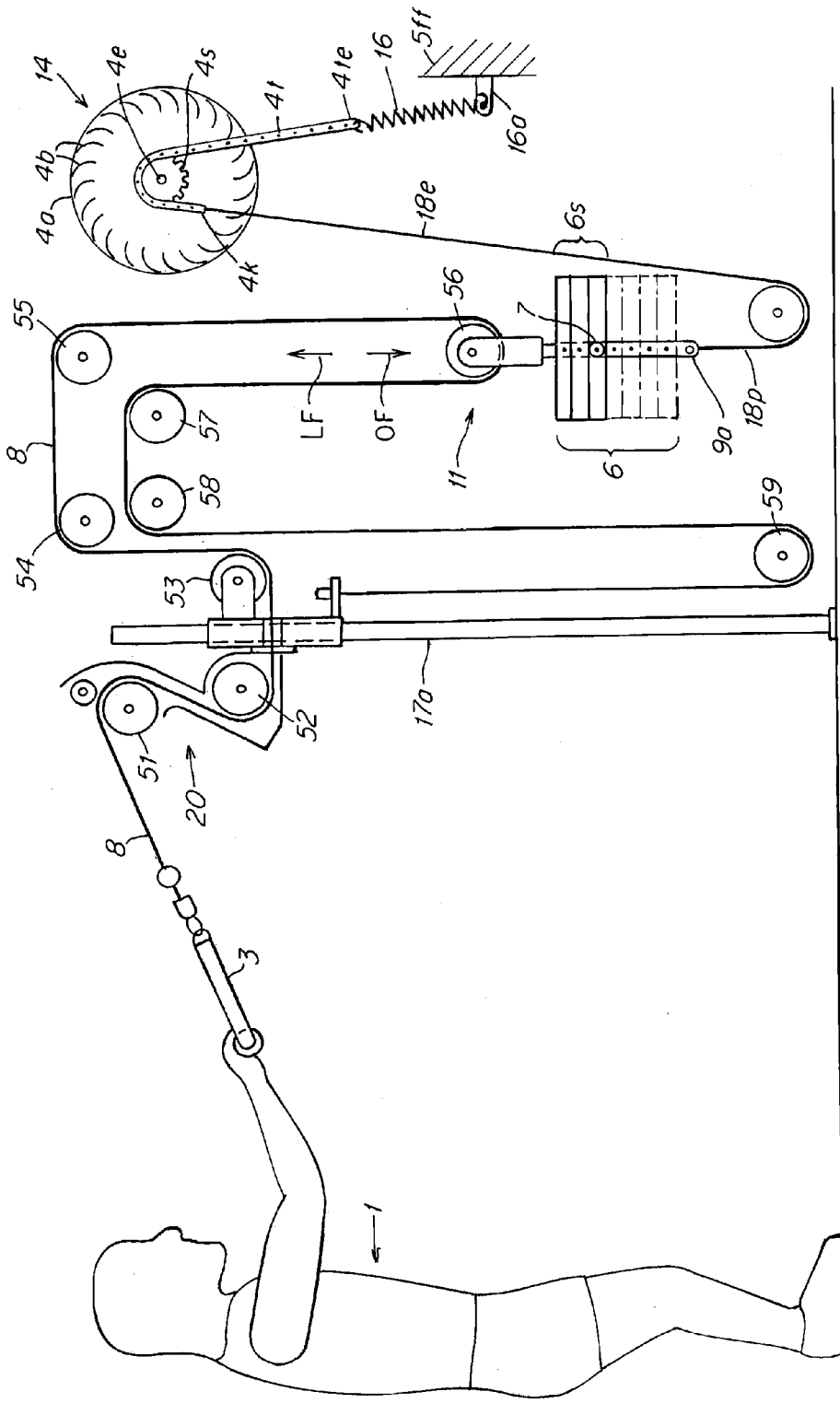

Fig. 5

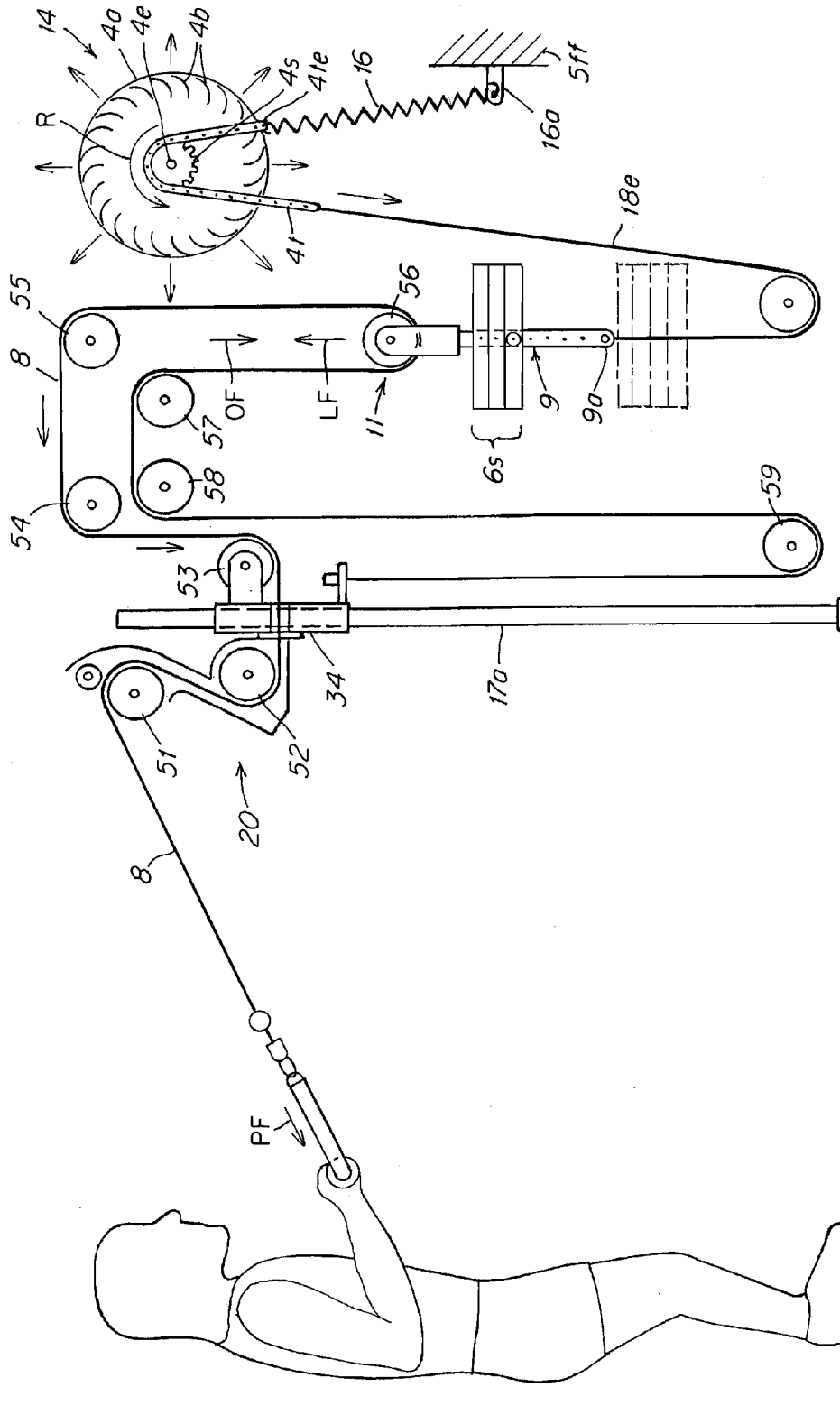

Fig. 6



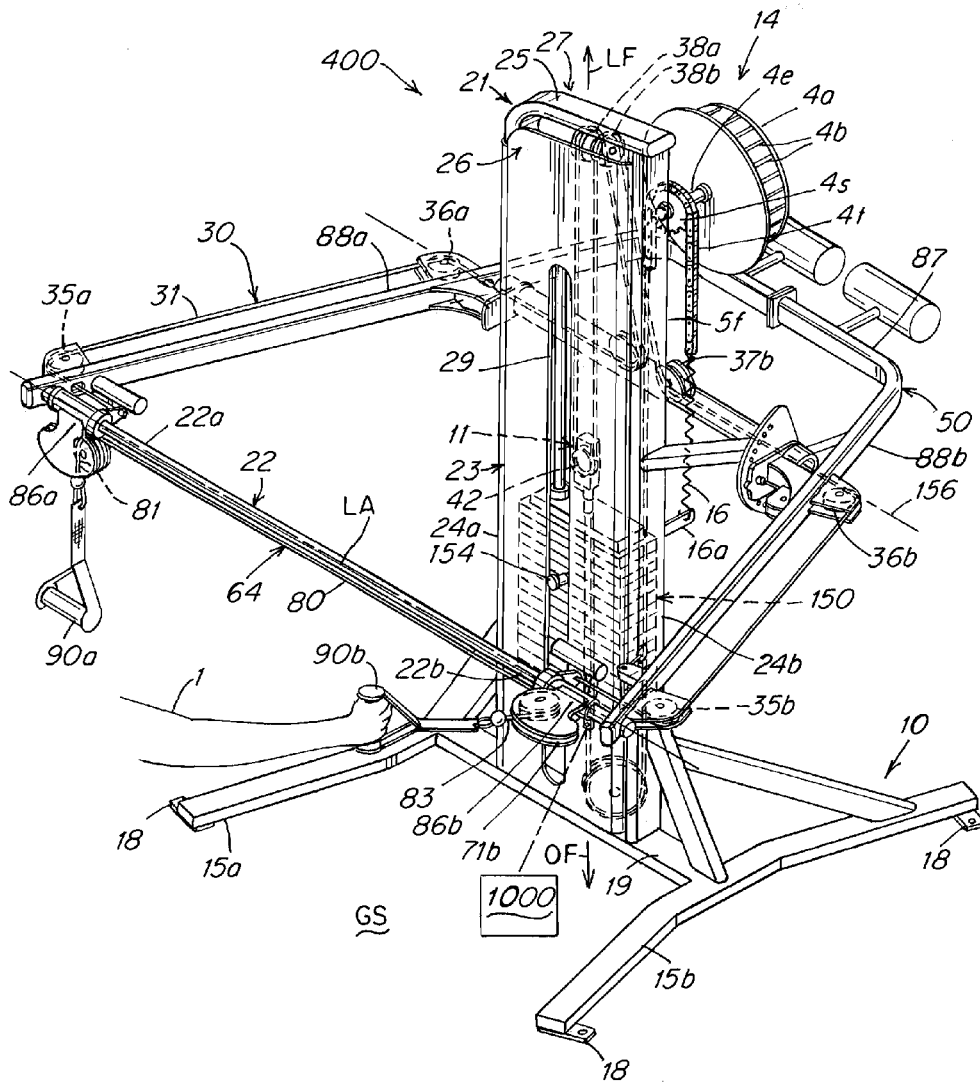
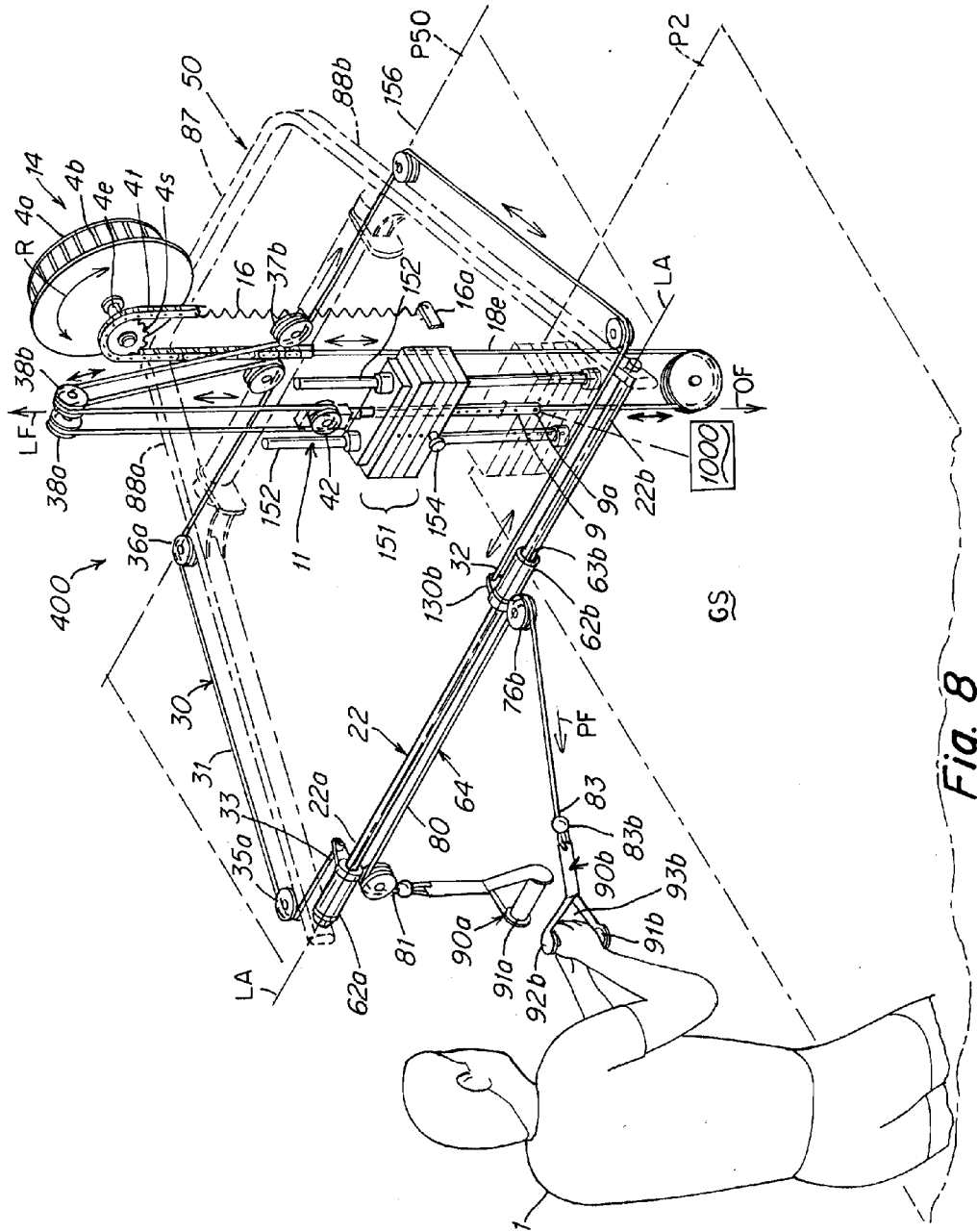

Fig. 7



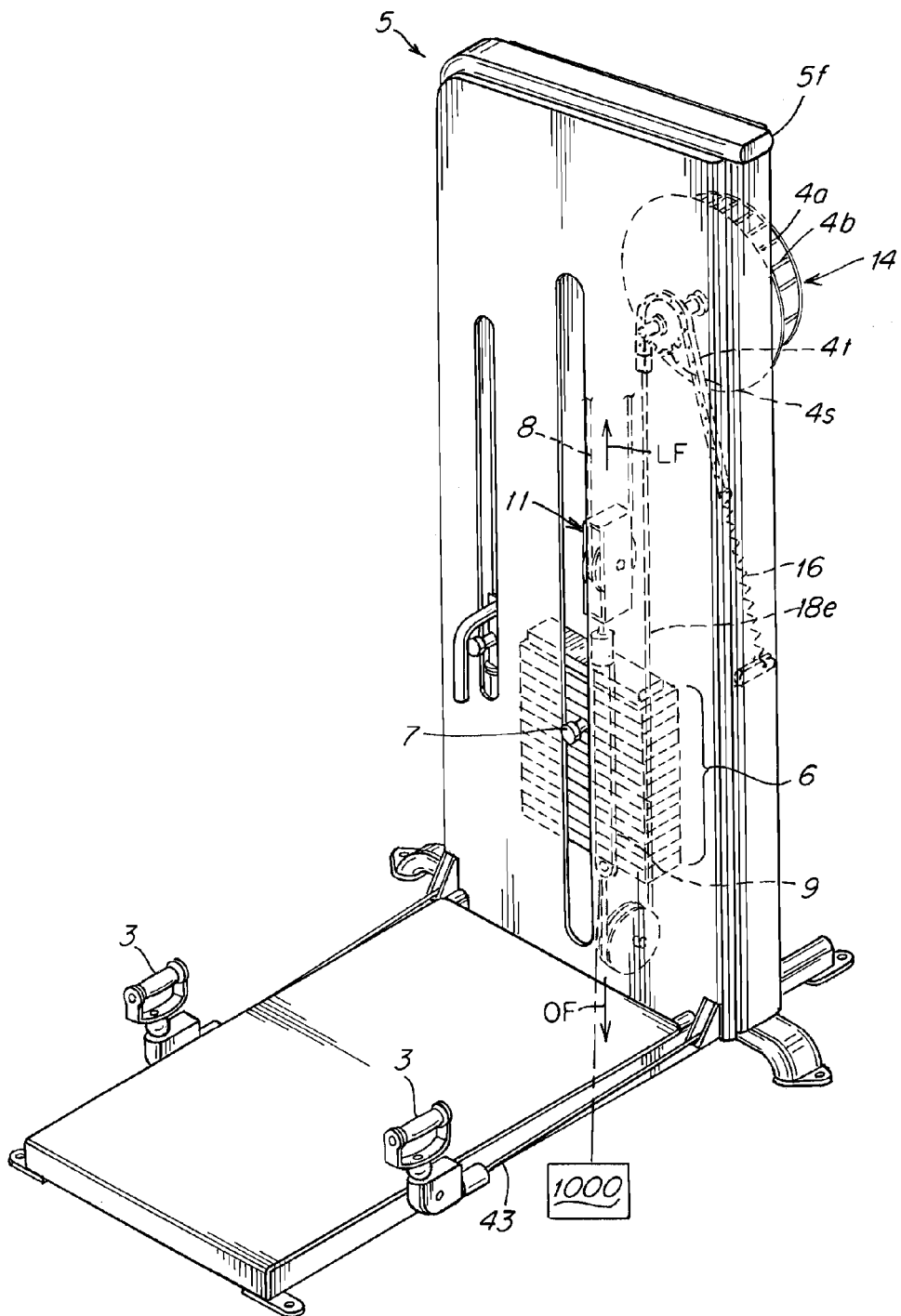

Fig. 9

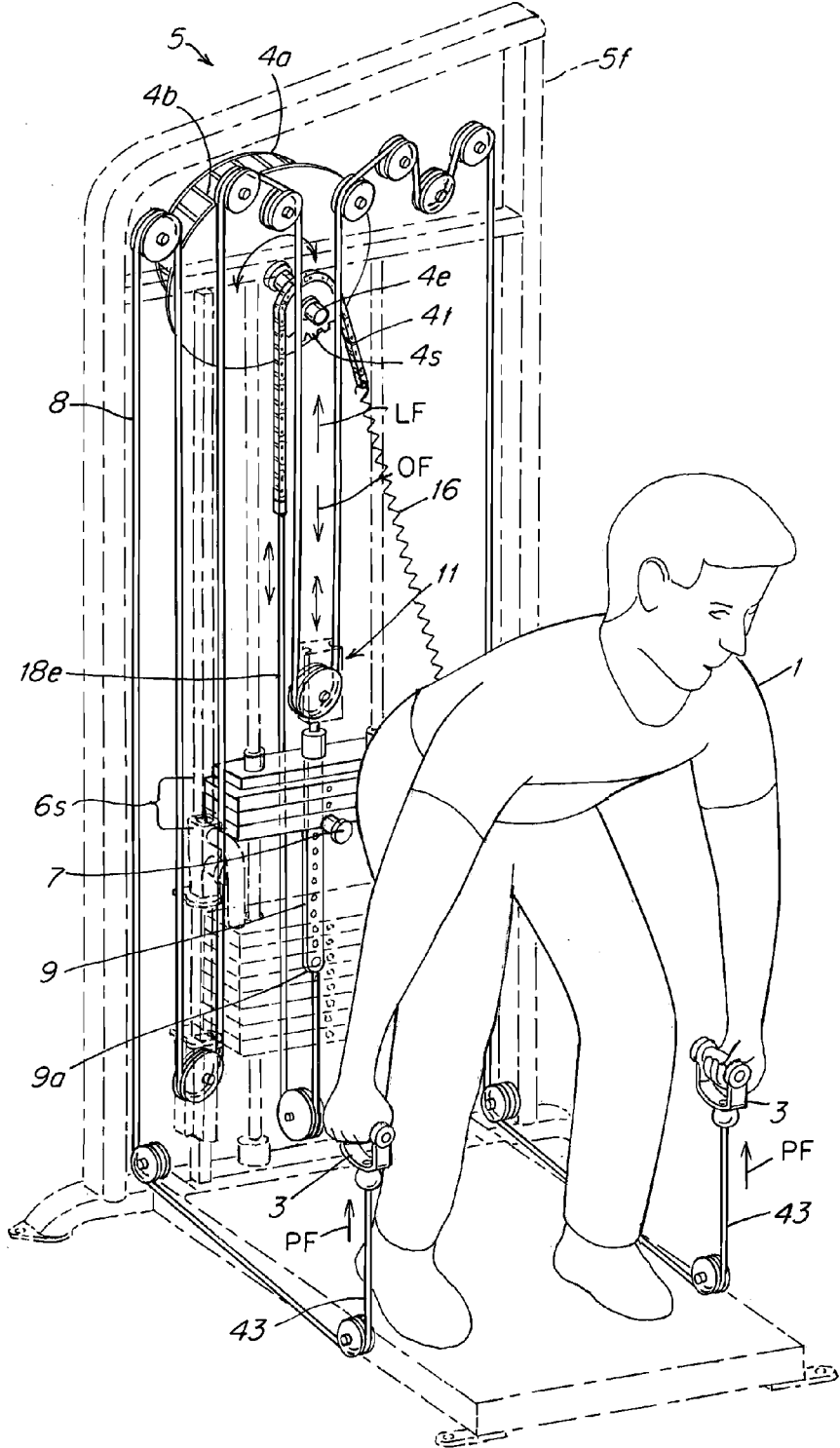

Fig. 10

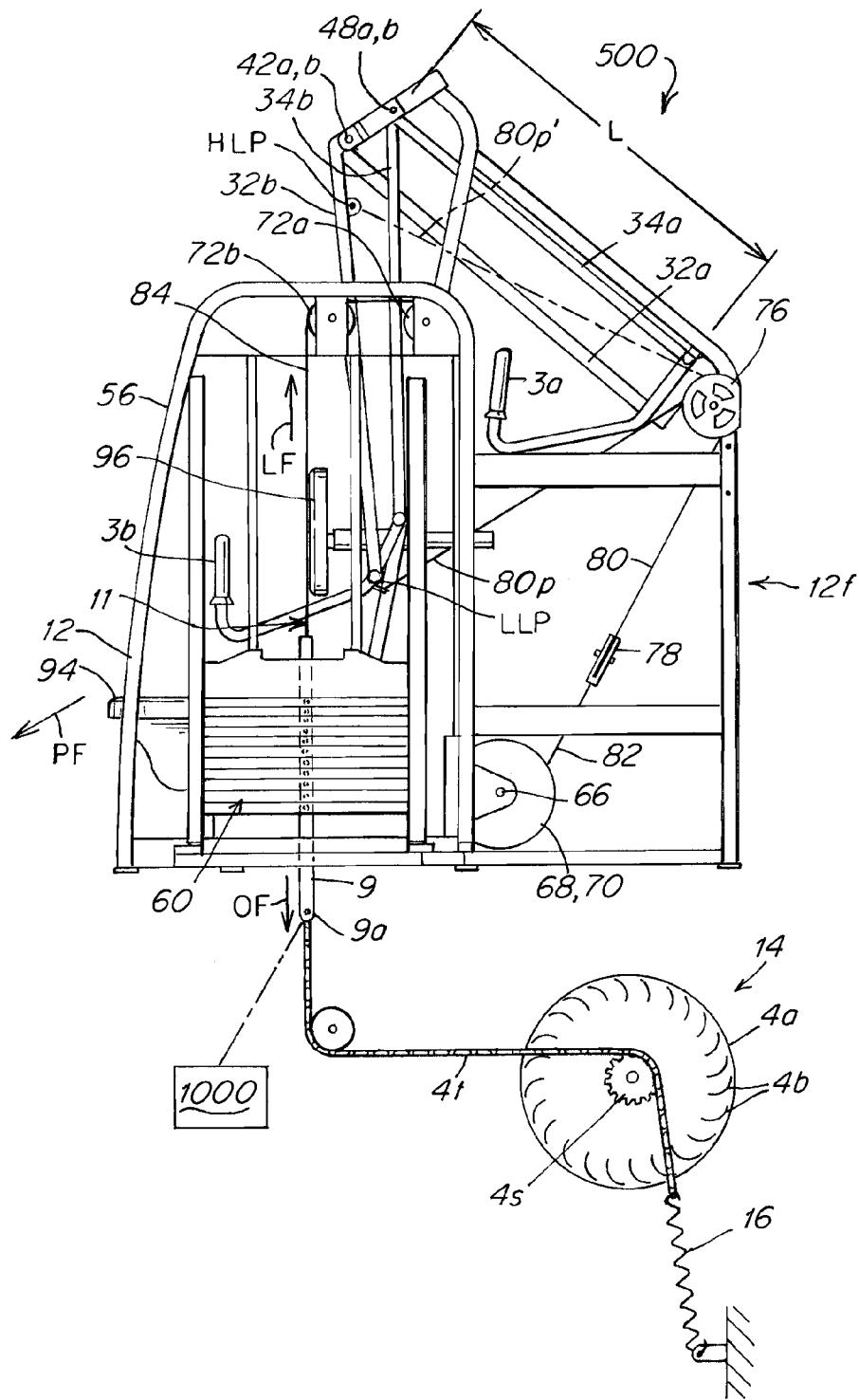

Fig. 11

## ADAPTIVE RESISTANCE EXERTING EXERCISE APPARATUS

### RELATED APPLICATIONS

**[0001]** This application is a continuation of and claims the benefit of priority to U.S. application Ser. No. 14/982,678 filed Dec. 29, 2015 which in turn is a continuation application of PCT/US2014/056206 filed Sep. 18, 2014 which claims the benefit of priority to U.S. provisional patent application ser. no. 61/879,334 filed Sep. 18, 2013 the disclosures of all of which are incorporated herein by reference in their entirety as if fully set forth herein.

**[0002]** This application incorporates by reference as if fully set forth herein in their entirety the disclosures of all of the following: U.S. Pat. No. 8,025,609, U.S. Pat. No. 7,278,955, U.S. Pat. No. 8,062,185, U.S. Pat. No. 8,057,363, U.S. Pat. No. 8,454,478, U.S. Pat. No. 8,827,877, U.S. Application Publication No. 20090176625 and U.S. Pat. No. 8,708,872, U.S. Pat. No. 8,057,367 and U.S. Patent Publication No. 2003/0166439, U.S. Patent Publication No. 2013/0040787, U.S. Patent Publication 20140005009 and U.S. Patent Publication No. 20030166439.

### FIELD OF THE INVENTION

**[0003]** The present invention relates to physical exercise machines and more particularly to an exercise apparatus that enables users to perform a weight lifting or other incremental weight movement exercise.

### BACKGROUND OF THE INVENTION

**[0004]** Exercise machines for lifting discrete amounts of non-varying weight are known and used for use in a variety of machines. The degree of resistance to performance of the exercise varies incrementally and linearly with the degree of force or speed exerted by the user.

### SUMMARY OF THE INVENTION

**[0005]** In accordance with the invention there is provided an exercise apparatus comprising:

**[0006]** a weight stack comprised of one or more individual bodies of discrete non-variable weight,

**[0007]** a flexible elongated cable having a proximal end and a downstream portion extending downstream from the proximal end of the cable,

**[0008]** the downstream portion of the cable mechanism being interconnected to a user selectable number of one or more individual bodies of weight that exert a first resistance and to a second resistance device that exerts a second resistance,

**[0009]** a manually movable actuating device interconnected to the proximal end of the cable,

**[0010]** the cable being arranged such that the actuating device is manually engageable and movable by a user to exert an exercise speed, velocity, force, energy or power on the proximal end of the cable that extends to the downstream portion of the cable, the downstream portion of the cable being directly connected both to the one or more individual bodies of weight and to the second resistance device in an arrangement that pulls in one direction on the one or more individual bodies of discrete, non-variable weight and pulls against the second resistance device,

**[0011]** the second resistance device exerting a degree of second resistance to movement of the actuating device that

varies non-linearly with the degree of exercise speed, velocity, force, energy or power exerted on the actuating device or on the second resistance device.

**[0012]** The apparatus is typically adapted such that movement of the actuating device by the user effects mechanical movement of a movable component of the second resistance device that increases the degree of the second resistance non-linearly with the degree of increase in speed or velocity of movement exerted on the movable component of the second resistance device or the actuating device.

**[0013]** The degree of the second resistance preferably varies geometrically or exponentially with the degree of exercise speed, velocity, force, energy or power exerted on the actuating device or the second resistance device.

**[0014]** The second force resistance device typically comprises a wheel having a drivably rotatable axle interconnected to one or more blades that forcibly engage against air on rotation of the axle, the wheel being interconnected to the downstream portion of the cable in an arrangement wherein the axle of the wheel is rotatably driven by the exercise speed, velocity, force, energy or power exerted by the user on the actuating device.

**[0015]** The axle of the wheel is preferably spring-load biased against rotation by the exercise speed, velocity, force, energy or power exerted by the user on the actuating device.

**[0016]** The degree of the second resistance typically varies non-linearly with the speed of rotation of the wheel.

**[0017]** The degree of the second resistance typically varies exponentially or geometrically with the speed of rotation of the wheel.

**[0018]** The manually movable actuating device can comprise a handle, a pivotable lever or a wheel interconnected to the proximal end of the cable.

**[0019]** The manifold is typically selectively interconnectable to a selectable number of the individual bodies of weight.

**[0020]** In another aspect of the invention there is provided a method of performing an exercise by a user comprising the user's selectively exerting a pulling or pushing force on the actuating device of the apparatus described above.

**[0021]** In another aspect of the invention there is provided a method of performing a weight lifting exercise on an exercise apparatus comprised of a weight stack comprised of one or more individual bodies of weight, a flexible elongated cable having a proximal end interconnected to a manually movable actuating device and a downstream portion extending downstream from the proximal end of the cable,

**[0022]** the method comprising:

**[0023]** connecting the downstream portion of the cable mechanism directly to a user selectable number of one or more individual bodies of weight,

**[0024]** arranging the cable such that the actuating device is interconnected to the proximal end of the cable and is manually engageable by a user to exert an exercise speed, velocity, force, energy or power on the proximal end of the cable via the actuating device that extends through the cable to the downstream portion of the cable,

**[0025]** interconnecting the downstream portion of the cable in an arrangement such that the downstream portion of the cable pulls in one direction on the one or more individual bodies of weight via the exercise speed, velocity, force, energy or power exerted by the user,

**[0026]** connecting the downstream portion of the cable directly to a second resistance mechanism in an arrangement

that pulls on the second resistance mechanism such that the second resistance mechanism exerts a second resistance against the exercise speed, velocity, force, energy or power in a direction opposite the one direction,

[0027] adapting the second resistance mechanism to exert the second resistance in a manner that varies non-linearly with one or more of the degree of exercise speed, velocity, force, energy or power exerted by the user on the second resistance mechanism or the actuating device.

[0028] The second resistance mechanism is preferably adapted to exert the second resistance in a manner that varies either exponentially or geometrically with the degree of exercise speed, velocity, force, energy or power exerted by the user.

[0029] The method typically further comprises adapting the force resistance mechanism to include a mechanical member that mechanically moves in response to the exercise speed, velocity, force, energy or power exerted by the user, the movement of the mechanical member mechanically generating the second resistance to vary non-linearly with the exercise speed, velocity, force, energy or power exerted by the user.

[0030] The method typically further comprises adapting the second resistance mechanism to exert the second resistance in a manner that varies exponentially or geometrically with the degree of exercise speed, velocity, force, energy or power exerted by the user on the second resistance mechanism or the actuating device.

[0031] In another aspect of the invention there is provided an exercise apparatus comprising:

[0032] a weight stack comprised of one or more individual bodies of discrete non-variable weight,

[0033] a flexible elongated cable having a proximal end and a downstream portion extending downstream from the proximal end of the cable,

[0034] the downstream portion of the cable mechanism being interconnected to a manifold that is directly connectable to a user selectable number of one or more individual bodies of weight that exert a first resistance and directly connected to a second resistance device that exerts a second resistance,

[0035] a manually movable actuating device interconnected to the proximal end of the cable,

[0036] the cable being arranged such that the actuating device is manually engageable and movable by a user to exert an exercise speed, velocity, force, energy or power on the proximal end of the cable that extends to the downstream portion of the cable and the manifold, the manifold being directly connected to the one or more individual bodies of weight in an arrangement that acts to pull in one direction on the one or more individual bodies of discrete, non-variable weight and to pull on the second resistance device,

[0037] the manifold being directly connected to a movable component of the second resistance device such that an increase in the user's exertion of the exercise speed, velocity, force, energy or power on the actuating device results in movement of the movable component which exerts a degree of second resistance to movement of the actuating device that increases non-linearly with an increase in the degree of speed, velocity, force, energy or power exerted on the movable component or on the actuating device.

[0038] The degree of the second resistance preferably varies exponentially or geometrically with the degree of

speed, velocity, force, energy or power exerted on the movable component or on the actuating device.

[0039] In another aspect of the invention there is provided an exercise apparatus comprising:

[0040] first and second manually movable actuating devices, each being interconnected to first and second cables respectively, the first and second cables being directly connected to first and second weight stacks respectively each comprised of first and second sets of one or more individual bodies of weight,

[0041] the first and second cables each having first and second downstream portions respectively interconnected to the first and second user selectable sets of the one or more individual bodies of weight and to third and fourth resistance devices respectively, the first and second sets of one or more individual bodies of weight exerting first and second resistances respectively and the third and fourth resistance devices exerting third and fourth resistances,

[0042] the first and second manually movable actuating devices being respectively interconnected to first and second proximal ends of the first and second cables, the first and second actuating devices being manually movable by the user to exert first and second exercise speeds, velocities, forces, energies or powers respectively through the first and second cables to the first and second downstream portions of first and second cables, the first and second downstream portions of the cables respectively pulling directly against the weight of the first and second sets of one or more individual bodies of weight and against the third and fourth resistance devices,

[0043] the third and fourth resistances exerted by the third and fourth resistance devices each respectively increasing non-linearly with an increase in the degree of speed, velocity, force, energy or power exerted on the first and second manually movable actuating devices or on the third and fourth resistance devices by the user.

[0044] In such an apparatus movement of the first and second manually movable actuating devices by a user preferably effects mechanical movement respectively of third and fourth movable components of the third and fourth resistance devices that respectively increases the degree of the third and fourth resistances non-linearly with the degree of increase in speed or velocity of movement exerted on the movable component of the third and fourth resistance devices or the first and second actuating devices respectively.

[0045] In such an apparatus, the degree of the third and fourth resistances typically varies geometrically or exponentially with the degree of exercise speed, velocity, force, energy or power exerted on the first and second actuating device or the third and fourth resistance devices.

[0046] In such an apparatus the third and fourth resistance devices typically comprise third and fourth wheels respectively each having a drivably rotatable axle interconnected to one or more blades that forcibly engage against air on rotation of the axle, the third and fourth wheels being interconnected respectively to the first and second downstream portions of the first and second cables respectively in an arrangement wherein the axles of the third and fourth wheels are rotatably driven by the exercise speed, velocity, force, energy or power exerted by the user on the first and second actuating devices.

[0047] The axles of the wheels are preferably spring-load biased against rotation by the exercise speed, velocity, force, energy or power exerted by the user on the first and second actuating devices.

[0048] The degree of the third and fourth resistances typically varies non-linearly with the speed of rotation of the third and fourth wheels.

[0049] The degree of the third and fourth resistances typically varies exponentially or geometrically with the speed of rotation of the third and fourth wheels respectively.

[0050] The first and second manually movable actuating devices preferably each comprises a handle each being interconnected to a pivotable lever or a wheel that is interconnected to the first and second proximal ends of the first and second cables respectively.

[0051] The first and second downstream portions of the first and second cables are preferably directly connected to first and second manifolds respectively that are directly connectable to a selectable number of the individual bodies of weight of the first and second sets of individual bodies of weight respectively.

[0052] In another aspect of the invention there is provided a method of performing an exercise by a user comprising the user's selectively exerting a pulling or pushing force on one or the other or both of the manually movable actuating devices of the apparatus of the apparatuses described above.

[0053] In another aspect of the invention there is provided an exercise apparatus comprising:

[0054] a weight stack comprised of one or more individual bodies of weight,

[0055] a flexible elongated cable having a downstream portion that is connected to a manifold that is connected to both a user selectable number of the one or more individual bodies of weight and to a second resistance device, the one or more individual bodies of weight exerting a first resistance and the second resistance device exerting a second resistance,

[0056] a manually movable actuating device interconnected to a proximal end of the cable, the actuating device being manually movable by the user to exert an exercise speed, velocity, force, energy or power through the cable to the downstream portion of the cable and the manifold, the manifold pulling via the cable directly against the weight of the one or more individual bodies of weight and against the second resistance device,

[0057] the second resistance exerted by the second resistance device increasing non-linearly with an increase in the degree of speed, velocity, force, energy or power exerted on the actuating device or on the second resistance device by the user.

[0058] In another aspect of the invention there is provided an exercise apparatus comprising:

[0059] a weight stack comprised of one or more individual bodies of weight,

[0060] a flexible elongated cable having a downstream portion that is interconnected to a user selectable number of the one or more individual bodies of weight that exert a first resistance and to a second resistance device that exerts a second resistance,

[0061] a manually movable actuating device interconnected to a proximal end of the cable, the actuating device being manually movable by the user to exert an exercise speed, velocity, force, energy or power through the cable on

the selectable number of one or more individual bodies of weight and on the second resistance device,

[0062] the second resistance device exerting a second resistance that increases non-linearly with an increase in the degree of speed, velocity, force, energy or power exerted on the actuating device or on the second resistance device by the user.

[0063] In another aspect of the invention there is provided an exercise apparatus comprising:

[0064] a weight stack comprised of one or more individual bodies of discrete non-variable weight,

[0065] a flexible elongated cable having a proximal end and a downstream portion extending downstream from the proximal end of the cable,

[0066] the downstream portion of the cable mechanism being interconnected to a user selectable number of one or more individual bodies of weight that exert a first resistance and to a second resistance device that exerts a second resistance,

[0067] a manually movable actuating device interconnected to the proximal end of the cable,

[0068] the cable being arranged such that the actuating device is manually engageable and movable by a user to exert an exercise speed, velocity, force, energy or power on the proximal end of the cable extending to the downstream portion of the cable to act in one direction on the one or more individual bodies of discrete, non-variable weight and on the second resistance device,

[0069] the second resistance device exerting a degree of second resistance to movement of the actuating device by the user that varies non-linearly with the degree of exercise speed, velocity, force, energy or power exerted on the actuating device or on the second resistance device, the second resistance being exerted in a direction opposite the one direction.

[0070] In such an apparatus movement of the actuating device by the user preferably effects mechanical movement of a movable component of the second resistance device that increases the degree of the second resistance non-linearly with the degree of increase in speed or velocity of movement exerted on the movable component of the second resistance device or the actuating device.

[0071] The degree of the second resistance preferably varies geometrically or exponentially with the degree of exercise speed, velocity, force, energy or power exerted on the actuating device or the second resistance device.

[0072] The second force resistance device typically comprises a wheel having a drivably rotatable axle interconnected to one or more blades that forcibly engage against air on rotation of the axle, the wheel being interconnected to the downstream portion of the cable in an arrangement wherein the axle of the wheel is rotatably driven by the exercise speed, velocity, force, energy or power exerted by the user on the actuating device.

[0073] The axle of the wheel is preferably spring-load biased against rotation by the exercise speed, velocity, force, energy or power exerted by the user on the actuating device.

[0074] The degree of the second resistance typically varies non-linearly with the speed of rotation of the wheel.

[0075] The degree of the second resistance typically varies exponentially or geometrically with the speed of rotation of the wheel.



**[0076]** The manually movable actuating device preferably comprises a handle, a pivotable lever or a wheel interconnected to the proximal end of the cable.

**[0077]** The downstream portion of the cable is preferably interconnected to a manifold that is interconnected to the second resistance mechanism, the manifold being selectively interconnectable to a selectable number of the individual bodies of weight.

**[0078]** In another aspect of the invention there is provided a method of performing a weight lifting exercise on an exercise apparatus comprised of a weight stack comprised of one or more individual bodies of weight, a flexible elongated cable having a proximal end interconnected to a manually movable actuating device and a downstream portion extending downstream from the proximal end of the cable,

**[0079]** the method comprising:

**[0080]** interconnecting the downstream portion of the cable mechanism to a user selectable number of one or more individual bodies of weight,

**[0081]** arranging the cable such that the actuating device is manually engageable by a user to exert an exercise speed, velocity, force, energy or power on the proximal end of the cable extending to the downstream portion of the cable to act in one direction to move the selected number of the one or more individual bodies of weight,

**[0082]** interconnecting the downstream portion of the cable to a second resistance mechanism in an arrangement such that the second resistance mechanism exerts a second resistance against the exercise speed, velocity, force, energy or power in a direction opposite the one direction,

**[0083]** adapting the second resistance mechanism to exert the second resistance in a manner that varies non-linearly with one or more of the degree of exercise speed, velocity, force, energy or power exerted by the user on the second resistance mechanism or the actuating device.

**[0084]** In such a method, the second resistance mechanism can be adapted to exert the second resistance in a manner that varies either exponentially or geometrically with the degree of exercise speed, velocity, force, energy or power exerted by the user.

**[0085]** Such a method can further comprise adapting the force resistance mechanism to include a mechanical member that mechanically moves in response to the exercise speed, velocity, force, energy or power exerted by the user, the movement of the mechanical member mechanically generating the second resistance to vary non-linearly with the exercise speed, velocity, force, energy or power exerted by the user.

**[0086]** In such a method, the second resistance mechanism can comprise a wheel having a drivably rotatable axle interconnected to one or more blades that forcibly engage against air on rotation of the axle, the wheel being interconnected to the downstream portion of the cable in an arrangement wherein the axle of the wheel is rotatably driven by the exercise speed, velocity, force, energy or power exerted by the user.

**[0087]** In such a method the wheel is typically biased by a spring against rotation by the exercise speed, velocity, force, energy or power exerted by the user.

**[0088]** Such a method can further comprise adapting the wheel such that the speed of rotation of the wheel varies non-linearly with one or more of the degree of exercise speed, velocity, force, energy or power exerted by the user on the wheel or the actuating device.

**[0089]** Such a method can further comprise adapting the wheel such that the speed of rotation of the wheel varies exponentially or geometrically with the degree of exercise speed, velocity, force, energy or power exerted by the user on the wheel or the actuating device.

**[0090]** Such a method can further comprise adapting the wheel to vary the second resistance either exponentially or geometrically with the degree of exercise speed, velocity, force, energy or power exerted by the user on the wheel or the actuating device.

**[0091]** Such a method can further comprise adapting the wheel to vary the second resistance non-linearly with the speed of rotation of the wheel.

**[0092]** In another aspect of the invention there is provided an exercise apparatus comprising:

**[0093]** a weight stack comprised of one or more individual bodies of discrete non-variable weight,

**[0094]** a flexible elongated cable having a proximal end and a downstream portion extending downstream from the proximal end of the cable,

**[0095]** the downstream portion of the cable mechanism being interconnected to a user selectable number of one or more individual bodies of weight that exert a first resistance and to a second resistance device that exerts a second resistance,

**[0096]** a manually movable actuating device interconnected to the proximal end of the cable,

**[0097]** the cable being arranged such that the actuating device is manually engageable and movable by a user to exert an exercise speed, velocity, force, energy or power on the proximal end of the cable extending to the downstream portion of the cable to act in one direction on the one or more individual bodies of discrete, non-variable weight and on the second resistance mechanism,

**[0098]** the downstream portion of the cable being interconnected to a movable component of a second resistance device such that an increase in the user's exertion of the exercise speed, velocity, force, energy or power on the actuating device results in movement of the movable component which exerts a degree of second resistance to movement of the actuating device that increases non-linearly with an increase in the degree of speed, velocity, force, energy or power exerted on the movable component or on the actuating device.

**[0099]** In such an apparatus, the movable component can comprise a fan that rotates at a selected speed or velocity in response to the user's exertion of a selected degree of the speed, velocity, force, energy or power exerted on the actuating device, the second degree of resistance exerted by the fan increasing non-linearly with an increase in the selected speed or velocity of rotation of the fan.

**[0100]** In such an apparatus, the second degree of resistance exerted by the fan can increase by a cube factor of increase in the selected speed or velocity of rotation of the fan.

**[0101]** In all such an apparatuses and methods according to the invention the second resistance mechanism can mechanically vary resistance to a degree that varies either exponentially or geometrically with the degree of speed, velocity, force, work or power exerted by the user on a mechanically movable component of the apparatus such as a handle, a cable or another movable device or assembly. The term "non-linear" or "non-linearly" is meant to encompass and include an exponential or geometric relationship

such as a cubed or cube factor relationship between an increase in degree of resistance and an increase in degree of speed, velocity, force, work or power exerted by the user. Also, as discussed below, the term “force” is intended to encompass and include user exerted power, energy or work which are all directly proportional to force.

#### BRIEF DESCRIPTION OF THE DRAWINGS

[0102] The above and further advantages of the invention may be better understood by referring to the following description in conjunction with the accompanying drawings in which:

[0103] FIG. 1 is a front perspective view of an exercise apparatus having an incremental weight and associated lifting mechanism without a means for preventing the user from exerting an excess of force on the incremental weights.

[0104] FIG. 2 is a top view of the apparatus of FIG. 1 showing a non-linearly force varying resistance mechanism interconnected to the incremental weight lifting mechanism.

[0105] FIG. 3 is a front right perspective view taken along lines 3-3 of FIG. 2 showing the detail of the interconnection of the non-linearly force varying resistance mechanism to the weight lifting mechanism. FIG. 3A is a plot of opposing force OF versus speed of rotation SR.

[0106] FIG. 4 is a more inclusive front right perspective view of the apparatus of FIG. 2.

[0107] FIG. 5 is a schematic side view of the apparatus of FIGS. 2-4 showing the user in a weight lift exercise start position.

[0108] FIG. 6 is a schematic side view of the apparatus of FIGS. 2-4 showing the user in a weight lift exercise position subsequent to the start position where the user is exerting force to lift one or more of the incremental weights and the non-linearly varying force resistance mechanism is opposing the exercise force.

[0109] FIG. 7 is a top perspective schematic view of another example of an exercise apparatus having a user engageable weight lifting subassembly interconnected to a non-linearly varying resistance mechanism showing the user in an exercise start position.

[0110] FIG. 8 is a view of the FIG. 7 apparatus showing the user in a subsequent exercise position exerting an exercise force on the weight stack and non-linearly varying force resistance mechanism.

[0111] FIG. 9 is front perspective view of another example of an exercise apparatus having a user engageable weight lifting subassembly interconnected to a non-linearly varying resistance mechanism showing the user in an exercise start position.

[0112] FIG. 10 is a left front view of the apparatus of FIG. 9 showing the user in a subsequent exercise position exerting an exercise force on the weight stack and non-linearly varying force resistance mechanism.

[0113] FIG. 11 is a side schematic view of another example of an exercise apparatus having a user engageable weight lifting subassembly interconnected to a non-linearly varying resistance mechanism according to the invention.

#### DETAILED DESCRIPTION

[0114] FIGS. 1-6 show one example of an exercise apparatus comprised of a weight stack 6 that is comprised of one or more individual bodies of discrete weight, a flexible elongated cable 8 having a downstream portion 11 that is

interconnected to a user selectable number of the one or more individual bodies of weight that exert a first resistance and to a second resistance device 14 that exerts a second resistance, a manually movable actuating device 3 interconnected to a proximal end 8p of the cable, the actuating device 3 being manually movable by the user to exert an exercise speed, velocity, force, energy or power PF through the cable 8 on the selectable number of one or more individual bodies of weight 6 and on the second resistance device 14, the second resistance device exerting a second resistance OF that increases non-linearly with an increase in the degree of speed, velocity, force, energy or power exerted PF on the actuating device 3 or on the second resistance device 14 by the user.

[0115] FIG. 1 shows one example of an exercise apparatus 5 having a stack of incremental weights 6 interconnected to a handle 3 that is interconnected to a proximal end of a weight lifting cable 8. The handle 3 is manually engageable by a user 4 to exert a pulling or pushing exercise force PF. The incremental weights 6 provide a resistance that is constant and does not vary non-linearly with the degree of force PF, LF exerted by the user but rather varies directly with the amount of the weights 6. The weights are mounted and arranged to enable the user 4 to selectively interconnect via a pin 7 any desired number 6s of the weights 6 to a manifold 9, which is in turn interconnected to a downstream portion 11 of the cable 8. The stack of incremental weights 6 are slidably mounted on rails 13 within a housing 12 that mechanically mount the weights 6 for movement along a predefined direction of travel 140, FIG. 3, when the downstream portion 11 of the cable exerts a lifting force LF on the manifold 9 that originates with the exercise force PF which is exerted downstream through the cable 8 to the downstream portion 11 to exert the lifting force in one direction LF. The stack 6 shown in the embodiments of the figures comprises a stack of separate individual bodies of weight, any selective number 6s of which can be interconnected to the main cable/pulley assembly before beginning an exercise, e.g. by inserting a pin 7 through a lateral aperture provided in each of the incremental weights in the stack 6 and continuing through a complementary aligned aperture provided in the weight-bearing rod or manifold 9 which is interconnected to pulley 56. Other varying weight resistance mechanisms can be provided in alternative embodiments such as free weights, containers fillable with a selective amount of fluid or the like.

[0116] As shown in FIG. 1 when the user exerts the exercise force PF which results in force LF being exerted on the manifold 9 and its interconnected incremental weights, the resistance mechanism 1000 exerts a force OF in addition to the weight force of the selected number 6s, FIGS. 5, 6, of a set of incremental weights 6 in opposition to the force LF along the direction OF. The resistance mechanism 1000 is adapted to vary the degree of opposing force OF in a non-linear relationship 300, FIG. 3A, relative to the degree of user exercise force LF, typically to increase the amount of opposing force OF exponentially or geometrically relative to an increase in exercise force PF. The non-linearly increasing resistance mechanism 1000 can comprise a mechanical, electromechanical (such as an eddy current brake), electrical or computer or software controlled mechanism that is interconnected in some fashion to the downstream portion 11 of

the cable **8** such as via attachment to the downstream end **9a** of the manifold **9** that is interconnected to the cable portion **11**.

**[0117]** As can be readily imagined, the non-linear, geometric, exponential or the like increase “resistance” that results from the use of a mechanism **1000** such as a fan **4a**, pertains equally to resistance as measured in units of force, work, energy and power which are all directly proportional to each other and which would all thus increase non-linearly or geometrically or exponentially with an increase of user exerted force PF, LF or the like. The term “non-linear” or “non-linearly” is meant to encompass and include an exponential or geometric relationship between the resistance and force exerted. Also, as discussed below, the term “force” is intended to encompass and include user exerted power, energy or work which are all directly proportional to force.

**[0118]** In the more specific embodiments shown in FIGS. 2-3, 4-8, the resistance mechanism **4** comprises a fan wheel **4a** having an axle **4c** mounted on a drive shaft **4e** driven by a chain **4t** that is meshed with a sprocket **4s** mounted to the shaft **4e**. The shaft is rotatably R mounted on the brackets **4g** via bearings **4f** that are mounted on brackets **4g** that are in turn mounted to the frame portion **5f** of the frame or apparatus **5**. Air resistance or fan blades **4b** having air impingement surfaces **4d** are mounted to the wheel **4a** and interconnected to the driven axle **4c** such that the blades **4b** rotate R in unison with the wheel **4a** causing the surfaces **4d** to impinge on ambient air and resist rotation R of the wheel **4a** and axle **4c**. The rate or speed of rotation SR, FIG. 3A of the axle **4c** and wheel **4a** varies in a non-linear, exponential or geometric fashion **310** with the degree of force that opposes the user OF, such force being generated by the impingement and flux of air resulting from rotation R of the wheel **4a** with the blades **4b** of the wheel **4a**. Typically the degree of resistance OF to rotation R of a fan or finned wheel **4a** increases or varies by a cube or cubed factor of or with the degree of speed of rotation R. Other resistance mechanisms other than a finned or fan wheel assembly **14** such as an Eddy current controlled brake mechanism can be employed that controllably increase, decrease or vary the degree of resistance generated by the resistance mechanism relative to the force F (or speed, velocity, power or energy) exerted by the user in a non-linear, geometric or exponential manner or relationship.

**[0119]** The axle **4c** is rotatably driven by the force PF, LF exerted by the user **1**, the force LF being transmitted to the chain **4t** via interconnection of a proximal end **18p** of the intermediate cable **18e** to the distal end **9a** of rod **9** such that the pull cable **18e** extends between the proximal end **4k** of the chain **4t** and the distal end **9a** of the manifold **9**. Exertion of the force LF causes the distal end of the intermediate pull cable **18e** to pull on the proximal end **4k** of the chain **4t** thus causing the chain **4t** to rotate R together with the drive shaft and further causing the distal end **4te** of the chain **4t** to pull on and stretch or extend the spring **16** creating a pull tension within the chain that acts to pull on the chain **4t** in the direction of the opposite force OF.

**[0120]** The distal end **4te** of the chain **4t**, FIG. 4, is interconnected to a spring **16** that is connected to an arm **16a** or other component that is fixedly interconnected to a frame portion **5ff** of the apparatus **5**. The spring **16** exerts a relatively small additional opposing force against the user exerted force LF when the cable portion **11** acts to exert LF on the selected number **6s** of incremental weights **6** thus

causing the spring **16** to be stretched or extended thus increasing the tension force in the spring and concomitantly increasing the opposing force OF. When the user **1** stops exerting the force LF, the distal end **9a** of the manifold **9** travels downstream toward the spring **16** thus allowing the chain **4t** to rotatably travel in the opposite direction OF around the sprocket **4s** downstream toward the spring **16** with the spring **16** being under tension and pulling on the distal end **4te** of the chain **4t** to cause the end **4te** to travel downstream and simultaneously keeping the chain **4t** under tension.

**[0121]** In the machine shown in FIGS. 1-3, 4-6, a main cable/pulley assembly **54**, **55**, **57**, **59** in which a single flexible cable **24** extends from the handle **3** through a rotating arm **20** which is attached via pulleys to the weight stack **6** and ultimately to the frame **5** seated on the floor via feet **18**. A second cable/pulley assembly **46**, **47**, **49** which functions as a counterbalance to the weight of the arm **20** is also shown. As shown the handle/arm **20** is disposed centrally along the height of the rail **17a**, which can be adjusted to alternative positions at lowermost and uppermost positions on the rail **17a**. The distal end of main cable **24** is shown extending from rotating arm **20**. The rotating arm **20** is disposed at a central vertical position, as determined by the position of slider **34** on the front upright frame member **17**. The arm is shown in a forwardly rotated position (with respect to the rear mounting frame element **5r** of the frame **5**). The cable **24** is routed through two pulleys **51-52** in the arm **20** and passes through the selected rotation position defined by rotation axis **2**. The cable **24** is further routed around a series of pulleys **53-59** which are all mounted such that when the handle **3** is pulled (or pushed) outwardly from the distal end of arm **20**, the downstream portion **11** of cable **24** that is routed around pulley **56** pulls upwardly on interconnected manifold **9** that is in turn interconnected to selected ones **6s** of the weight stack **6**.

**[0122]** In the machine shown in FIGS. 7, 8 a non-linear varying resistance mechanism **1000** that generates an opposing force OF to the user exercise force LF is generically shown as being interconnected to the distal end **9a** of a manifold **9** that enables a user **4u** to select a selected number **151** of a stack of incremental weights **150**. The mechanism typically increase the amount of force OF exponentially or geometrically with increase of lifting force LF. A specific embodiment of a resistance mechanism **14** having air resistance blades **4b** operates in the same fashion as described above regarding the wheel **14** and its associated components such that rotation R, SR of the wheel **14** creates an opposing force OF that varies non-linearly **310**, FIG. 3A with the degree of degree of speed, velocity, force PF, work or power exerted by the user on a mechanically movable component of the apparatus such as a handle **3**, a cable **8** or resistance mechanism wheel **4a**.

**[0123]** As shown in FIGS. 7, 8 the machine comprises a rod **12** having a longitudinal axis LA, the rod is mounted on the frame such that the longitudinal axis is disposed generally horizontally relative to the ground surface plane P2 which supports the frame and a user. The apparatus **10** includes a base member **14** disposed generally parallel and adjacent to a horizontal plane P2 of the ground surface **2**. The base **14** includes left and right elongated feet members **15a**, **15b**, joined by a cross bar **19**. At the ends of each foot are mounting pads **16** with holes for bolting the front and rear ends of the feet to the ground surface **2** to maintain the

machine in a stationary position. On top of the central cross bar 19 there is mounted a central vertical column or support 22 including a vertically-disposed housing 23 that encloses a weight stack 150. The housing includes left and right end supports (e.g., hollow tubes) 24a, 24b that are joined by a top support (e.g. hollow tube) 25, along with a front cover 26 and a rear cover 27 that define a central cavity 28 in which the weight stack resides. An elongated vertical opening 29 in the front cover 26 provides access to an adjustable pin 154 for selecting a number of weights in the stack to be attached to a connector (resistance) cable, thereby adjusting the amount of force required by the user to extend the pull handle assemblies 60a, 60b. The rod 12 on which the slidable handle bracket assemblies 60a and 60b are mounted, forms one side of a rectilinear pivot arm structure 50. The arm structure 50 includes left and right side arms 52a, 52b each joined at their rear ends to opposite ends of a transverse rear arm 51, wherein all three arms and the front rod 12 lie in a single horizontal plane P50 that in FIG. 1 is substantially parallel to the ground surface plane P2. With the pivot arm 50 in the middle position, the front rod 12 is in the same horizontal plane P50 as the arm structure 50, parallel to the ground surface plane, and the rod 12 is disposed roughly three feet above the ground surface plane P2. This central position provides easy access by a user standing in front of the machine 10 and rod 12 for engaging and grasping the handles 90a, 90b in order to pull on the handle(s) and as a result slide the handle bracket(s) across the rod 12.

[0124] The arm structure 50, FIGS. 7, 8 including left and right side arms 52a, 52b and supporting rod 12, can be pivoted about a generally horizontal axis which is disposed parallel to a ground surface plane. Pivoting the arm structure 50 clockwise about the axis enables the user to raise the front rod upwardly, so that the handle assemblies are now further away from the ground surface (e.g., about five feet above the ground 2) than in the middle position, while still maintaining the rod 12 in a plane substantially parallel to the ground surface plane. Alternatively, pivot arm 50 can be pivoted in the opposite direction (counterclockwise), lowering the rod so that the handles are now closer to the ground, FIGS. 7, 8 and a user 4u disposed in front of the machine now will pull upwardly on the handles. Again, the rod is always maintained in a substantially horizontal plane parallel to the ground surface plane, but the distance from the ground surface plane varies depending on the pivoted position of arm structure 50 on the frame.

[0125] The pull cable assembly 68 is directly engaged by the user; it includes a pull cable 80 having a left end 81 engagable with the left slidable handle bracket 60a, and a right cable end 82 engagable with the right slidable handle bracket 60b. The left and right handle brackets 60a, 60b are initially disposed at opposing left and right ends 13a, 13b of the rod 12. When a user grasps the grip 91b of right handle 90b and pulls it toward himself, the right handle bracket 60b is caused to slide across the rod 12 toward the left handle bracket 60a, the latter being fixed in position on the left hand end 13a of rod 12 by its engagement with the resistance cable assembly 30 attached to the weight stack 150.

[0126] More specifically, the right handle bracket 60b includes a slidable sleeve (e.g., tube) 62b having a central bore 63b which slidably engages the outer cylindrical surface of rod 12. A pulley housing 71b attached to slidable tube 62b mounts a pulley wheel 76b, over which a pull cable 80

can be pulled (by a user) while the wheel rotates. At the right end 82 of pull cable 80, a stop ball 83b is provided that prevents the pull cable from being pulled out of the handle bracket 60b when the user pulls on the opposing handle 90a. The right end 82 of cable 80 is attached by a metal ring 84b to a Y-shaped handle frame 92b. A grip 91b is supported across the open ends 94b of the Y-shaped frame 92b, wherein an opening 93b between the grip and Y-shaped frame allows the user's fingers to be inserted for grasping the grip 91 b. The opposing end 95b of the Y-frame 92b has an aperture which receives the ring 84b for connecting the stop ball 83b between the handle 90b and pull cable 80.

[0127] The right handle bracket assembly 60b further includes a tabbed collar 130b attached to the slidable tube 62b for connecting the handle bracket 60b to the resistance cable assembly 30. More specifically, a first end 32 of resistance cable 31 is attached to the tab portion of the collar 130b. The resistance cable 31 extends from collar 130b around four right side pulley wheels 35b-38b, and then around a central pulley 42 which is attached to the weight stack 150. The opposing left end 33 of resistance cable 32 is similarly engaged with the left handle bracket 60a and a mirror image pulley assembly with four pulley wheels, and ultimately engages the same central pulley wheel 42 engaged with the same common weight stack 150. Thus, in the present embodiment, a single resistance cable assembly 30 connects the left and right slidable handle brackets 60a, 60b, while a separate pull cable assembly 68 similarly connects the left and right handle brackets 60a, 60b, and together the two separate cable assemblies 30 and 68, which each engage the left and right slidable handle brackets 60a, 60b, enable the resistance training motion and exercises illustrated in the figures.

[0128] When a user 4 grasps the right handle 90b and pulls the handle 90b toward himself while moving away from the machine 10, thereby extending the right handle away from the rod, he pulls against the resistance set by the resistance cable assembly 30 which is attached to a select number of weights in the weight stack 150. Here, an adjustable pin selects the upper 151 weights in the stack as a desired fixed weight resistance level, while the user pulls on the right handle these upper 151 weights rise upwardly along the parallel guide rods 152 of the weight stack. As a result the right handle bracket 62b slides to the left on the rod, allowing the pull cable 80 to extend further toward the user while the user continues to exert sufficient force to overcome the selected weight resistance 151 (upper weights of the stack). The left handle bracket 60a remains stationary with respect to the frame 5, the stop ball 83a preventing the pull cable 80 from disengaging with the left handle bracket, and the resistance cable 31 attached to the left handle bracket resisting the force on the pull cable 80 exerted by the user pulling on the right handle.

[0129] As shown in FIGS. 7, 8 the pivot arm structure 50 is rotated counterclockwise about its axis to a lowermost position, wherein the rod is now horizontally aligned in a plane much closer to the ground plane, here a minimum of about 45 inches above the ground. In this position, the user pulls upwardly on the right handle 90b, again overcoming the resistance of the selected ones of the incremental weights 151 in the weight stack 150. Such a machine as shown in FIGS. 7, 8 is disclosed in U.S. Patent Publication 20140005009, the disclosure of which is incorporated by reference as if fully set forth herein.

[0130] In the machine 5 shown FIGS. 9, 10, a downstream portion 11 of a pull cable 24 is attached at an upstream end 8 to handles 3. The downstream portion 11 is selectively interconnectable via selector pin 7 and rod 9 to a selected number of incremental weights 6s. When the user 4u exerts a pull force PF on the handles 3, an exercise lifting force LF is exerted via downstream portion 11 of cable 24 on and opposed by the incremental weights 6s via the mechanisms shown in FIGS. 9, 10. As in the above described embodiments of FIGS. 1-3, 4-8, the distal end 9a of the rod of the FIGS. 8, 10 apparatus is interconnected to a resistance mechanism 1000 that opposes OF the user's lifting force LF in a non-linearly increasing fashion 300, FIG. 3A, relative to the amount of lifting force LF. As in the above embodiments, the resistance mechanism 1000 can comprise a driven wheel assembly 14 having blades 4b attached to an axle that impinge on ambient air upon driven rotation R of the wheel 4a, the degree of resistance increasing non-linearly 310, FIG. 3B, with increasing speed or rate of rotation SR of the wheel 4a. Typically the degree of resistance increases exponentially or geometrically as with the above described embodiments. A machine as shown in FIGS. 9, 10 is described in full in U.S. Pat. No. 8,827,877 the disclosure of which is incorporated herein by reference in its entirety as if fully set forth herein.

[0131] In the machine shown in FIG. 11, the handles 38a and 38b are operably connected to the weight stack 60 via a transmission system. A pair of frame pulleys 76 are mounted to the vertical support of the support frame 12f. A lifting pulley 78 is operably connected to the handles 38a and 38b by a first cable 80, wherein the first cable 80 is threaded about and through the pair of frame pulleys 76, such that the lifting pulley 78 is positioned above the second cam 70. A lifting cable 82 connects the lifting pulley 78 to the second cam 70, where the second cam 70 is caused to rotate when at least one of the handles 38a or 38b is pulled back. A belt 84 is attached at one end to the first cam 68, extending over the weight stack pulleys 72a and 72b and attached to the weight stack 60 at the opposite end. As the user pulls back on the handles 38a and 38b, the lifting pulley 78 is raised, causing the lifting cable 80 to unwind and rotate the second cam 70. As the second cam 70 rotates, the shaft 66 and the first cam 68 rotate as well. The rotation of the first cam 68 pulls the belt 84 over the weight stack pulleys 72a and 72b, and thus lifts the weight stack 60.

[0132] In an exemplary method of operation, a weight is selected on the main weight stack 60 by placing a pin (not shown) in one of the complementary holes, as is known in the art. The user adjusts the seat 20 and chest pad 22 to a suitable position on the front leg. For example, a user with a longer torso will adjust the seat to a lower height such that the handles 38a and 38b are positioned at a comfortable height parallel with the users shoulders. The chest pad 22 is adjusted such that when the user grasps the handles tension is placed on the lifting cable 80. The user grasps the handles 38a and 38b and pulls back causing the lifting pulley 78 to be raised. As the lifting pulley 78 is raised, the first cam 70, shaft 66, and second cam 68 rotate, pulling on the belt 84 and lifting the selected weight. The user then returns the handles 38a and 38b to the initial position, thereby lowering the weight. When the user pulls the handles 38a and 38b back, the resistance provided by the weight is overcome. When the user returns the handles 38a and 38b, the user succumbs to the resistance provided by the weight stack 60.

[0133] As shown schematically in FIG. 11, the distal end 9a of weight bearing rod or manifold 9 is interconnected to a non-linearly varying resistance mechanism 1000 which can increase the amount of force OF exponentially or geometrically with increase of lifting force LF. Mechanism 1000 can take the more specific form of a wheel assembly 14 that exerts resistance OF that varies in a non-linear relationship 300, FIG. 3, with the degree of speed, velocity, force, work or power exerted by the user on a mechanically movable component of the apparatus such as a handle 3, a cable 8 or resistance mechanism or assembly 4a et al. The details of a rowing machine 500 as shown in FIG. 11 is disclosed in U.S. Patent Publication No. 20030166439, the disclosure of which is incorporated herein by reference as if fully set forth herein.

[0134] In the FIG. 11 machine, a user is typically seated on a bench or seat 94 with the user's chest engaged against a chest pad 96. In the starting position the handles are disposed forwardly of the user in the position where handle 3a is disposed as shown in FIG. 11. In performing an exercise, the user pulls on a handle 3a, 3b so as to cause the handle to travel toward the chest of the user until a handle is pulled to a position such as handle 3b is shown as being disposed in FIG. 11. As shown the handles 3a, 3b are attached to the proximal end of a four bar linkage or lever system, 32a, 34a near a low leverage point position LLP of one or more of the levers 32a or 34a or 32b or 34b. In the FIG. 11 example the proximal end portion 80p of the cable 80 is also attached to the lever 32a or 34a or 32b or 34b at a position at, near or adjacent the low leverage point or position LLP. In such a configuration when a user pulls on the handle 3a, 3b, the degree of force PF that the user must exert is relatively high because the cable is attached at a relatively low leverage point LLP of the levers 32a or 34a or 32b or 34b. In an alternative embodiment, the proximal end of the cable 80p' could be attached to a different position of a lever arm 32a or 34a or 32b or 34b which is a relatively high leverage point or position HLP along the length of a lever arm which provides the user with a higher degree of leverage when pulling PF against the weight force of the selected number of individual weights of the weight stack 60 as well as against the non-linearly increasing resistance that is generated by the resistance assembly 14 against the pulling force PF. Thus in the FIG. 11 example the handles 3a, 3b are not connected directly to the proximal end 80p or 80p' of the cable 80 but rather are interconnected via a lever arm 32a or 34a or 32b or 34b or another bracket or arm that is connected to a lever arm that can be varied in attachment position to vary the degree of force PF that a user must exert to lift a selected number of weights in the stack depending on the precise longitudinal position along the length L of the lever at which the proximal end 80p, 80p' of the cable 80 is attached.

[0135] In the embodiment of FIG. 11, the exercise machine 500 includes a support frame 12. The seat 94 is adapted to be positioned at various heights along the front leg of the frame to provide a comfortable position for users of varying stature. The chest pad 96 is mounted above the seat 20. The chest pad may be adjustable in vertical height such as by means of a telescoping rod held in position by a pin/detent connection. The chest pad 96 is also preferably adjustable at different distances forwardly and backwardly toward a seated user.

[0136] The manually movable actuating device for the machine 500 includes four bar linkage mechanisms pivotally mounted at the distal ends to an upper support frame. The four bar linkages are symmetrical in construction and include primary lever arm 32a, a secondary lever arm 34a, and a handle 38a. The primary lever arm 32a and secondary lever arm 34a lie and travel in a common plane which minimally diverges from a vertical midplane as the primary lever 32a and the secondary lever 34a are drawn. The divergence of the common plane is sufficient to allow the handles 3a and 3b to pass on opposite sides of the user. The primary lever arm 32a is an elongated bar which is pivotally connected at its proximal end to the handle 3a. The distal end of the primary lever arm 32a is pivotally connected to the upper support frame 36 by primary axle or pivot point 42a. Secondary lever arm 34a is similarly an elongated bar which is pivotally connected at its proximal end 8p to handle 3a, and is pivotally connected at its distal end to the upper support frame by secondary axle 48a. The secondary axle or pivot point 48a.

[0137] The weight stack 60 is mounted on the support frame 12 in a position where the weight stack 60 is easily accessed by a user seated in seat 94. The handles 3a and 3b are operably connected to the weight stack 60 via the cable 80 and manifold 9. In an exemplary method of operation, a weight is selected on the main weight stack 60 by placing a pin (not shown) in one of the holes, as is known in the art. The user adjusts the seat 94 and chest pad 96 to a suitable position. The chest pad 96 is adjusted such that when the user grasps the handles tension is placed on the lifting cable 80. The user grasps the handles 3a and/or 3b and pulls back causing the lifting pulley 78 to be raised. As the lifting pulley 78 is raised, the first cam 70, shaft 66, and second cam 68 rotate, pulling on the manifold 9 and lifting the selected weight. The user then returns the handles 3a and 3b to the initial position, thereby lowering the weight. When the user pulls PF the handles 3a, 3b the second resistance is also provided by the second resistance assembly 14 via the interconnection of chain 4t to the manifold at connection point 9a.

What is claimed is:

1. An exercise apparatus comprising:

- a weight stack comprised of one or more individual bodies of weight,
- a flexible elongated cable having a downstream portion that is connected to a manifold that is connected to both a user selectable number of the one or more individual bodies of weight and to a second resistance device, the one or more individual bodies of weight exerting a first resistance and the second resistance device exerting a second resistance,
- a manually movable actuating device interconnected to a proximal end of the cable, the actuating device being manually movable by the user to exert an exercise speed, velocity, force, energy or power through the cable to the downstream portion of the cable and the manifold, the manifold pulling via the cable directly against the weight of the one or more individual bodies of weight and against the second resistance device,
- the second resistance exerted by the second resistance device increasing non-linearly with an increase in the degree of speed, velocity, force, energy or power exerted on the actuating device or on the second resistance device by the user.

2. An exercise apparatus comprising:

- a weight stack comprised of one or more individual bodies of discrete non-variable weight,
- a flexible elongated cable having a proximal end and a downstream portion extending downstream from the proximal end of the cable,
- the downstream portion of the cable mechanism being interconnected to a user selectable number of one or more individual bodies of weight that exert a first resistance and to a second resistance device that exerts a second resistance,
- a manually movable actuating device interconnected to the proximal end of the cable,
- the cable being arranged such that the actuating device is manually engageable and movable by a user to exert an exercise speed, velocity, force, energy or power on the proximal end of the cable that extends to the downstream portion of the cable, the downstream portion of the cable being directly connected both to the one or more individual bodies of weight and to the second resistance device in an arrangement that pulls in one direction on the one or more individual bodies of discrete, non-variable weight and pulls against the second resistance device,
- the second resistance device exerting a degree of second resistance to movement of the actuating device that varies non-linearly with the degree of exercise speed, velocity, force, energy or power exerted on the actuating device or on the second resistance device.

3. The apparatus of claim 1 wherein movement of the actuating device by the user effects mechanical movement of a movable component of the second resistance device that increases the degree of the second resistance non-linearly with the degree of increase in speed or velocity of movement exerted on the movable component of the second resistance device or the actuating device.

4. The apparatus of claim 1 wherein the degree of the second resistance varies geometrically or exponentially with the degree of exercise speed, velocity, force, energy or power exerted on the actuating device or the second resistance device.

5. The apparatus of claim 1 wherein the second force resistance device comprises a wheel having a drivably rotatable axle interconnected to one or more blades that forcibly engage against air on rotation of the axle, the wheel being interconnected to the downstream portion of the cable in an arrangement wherein the axle of the wheel is rotatably driven by the exercise speed, velocity, force, energy or power exerted by the user on the actuating device.

6. The apparatus of claim 5 wherein the axle of the wheel is spring-load biased against rotation by the exercise speed, velocity, force, energy or power exerted by the user on the actuating device.

7. The apparatus of claim 5 wherein the degree of the second resistance varies non-linearly with the speed of rotation of the wheel.

8. The apparatus of claim 5 wherein the degree of the second resistance varies exponentially or geometrically with the speed of rotation of the wheel.

9. The apparatus of claim 2 wherein the manually movable actuating device comprises a handle, a pivotable lever or a wheel interconnected to the proximal end of the cable.

10. The apparatus of claim 2 wherein the manifold is selectively interconnectable to a selectable number of the individual bodies of weight.

11. A method of performing a weight lifting exercise on an exercise apparatus comprised of a weight stack comprised of one or more individual bodies of weight, a flexible elongated cable having a proximal end interconnected to a manually movable actuating device and a downstream portion extending downstream from the proximal end of the cable,

the method comprising:

connecting the downstream portion of the cable mechanism directly to a user selectable number of one or more individual bodies of weight,

arranging the cable such that the actuating device is interconnected to the proximal end of the cable and is manually engageable by a user to exert an exercise speed, velocity, force, energy or power on the proximal end of the cable via the actuating device that extends through the cable to the downstream portion of the cable,

interconnecting the downstream portion of the cable in an arrangement such that the downstream portion of the cable pulls in one direction on the one or more individual bodies of weight via the exercise speed, velocity, force, energy or power exerted by the user,

connecting the downstream portion of the cable directly to a second resistance mechanism in an arrangement that pulls on the second resistance mechanism such that the second resistance mechanism exerts a second resistance against the exercise speed, velocity, force, energy or power in a direction opposite the one direction,

adapting the second resistance mechanism to exert the second resistance in a manner that varies non-linearly with one or more of the degree of exercise speed, velocity, force, energy or power exerted by the user on the second resistance mechanism or the [text missing or illegible when filed]

12. The method of claim 11 wherein the second resistance mechanism is adapted to exert the second resistance in a manner that varies either exponentially or geometrically with the degree of exercise speed, velocity, force, energy or power exerted by the user.

13. The method of claim 11 further comprising adapting the force resistance mechanism to include a mechanical member that mechanically moves in response to the exercise speed, velocity, force, energy or power exerted by the user, the movement of the mechanical member mechanically generating the second resistance to vary non-linearly with the exercise speed, velocity, force, energy or power exerted by the user.

14. The method of claim 11 further comprising adapting the second resistance mechanism to exert the second resistance in a manner that varies exponentially or geometrically with the degree of exercise speed, velocity, force, energy or power exerted by the user on the second resistance mechanism or the actuating device.

15. An exercise apparatus comprising:

a weight stack comprised of one or more individual bodies of discrete non-variable weight,

a flexible elongated cable having a proximal end and a downstream portion extending downstream from the proximal end of the cable,

the downstream portion of the cable mechanism being interconnected to a manifold that is directly connectable to a user selectable number of one or more individual bodies of weight that exert a first resistance and directly connected to a second resistance device that exerts a second resistance,

a manually movable actuating device interconnected to the proximal end of the cable,

the cable being arranged such that the actuating device is manually engageable and movable by a user to exert an exercise speed, velocity, force, energy or power on the proximal end of the cable that extends to the downstream portion of the cable and the manifold, the manifold being directly connected to the one or more individual bodies of weight in an arrangement that acts to pull in one direction on the one or more individual bodies of discrete, non-variable weight and to pull on the second resistance device,

the manifold being directly connected to a movable component of the second resistance device such that an increase in the user's exertion of the exercise speed, velocity, force, energy or power on the actuating device results in movement of the movable component which exerts a degree of second resistance to movement of the actuating device that increases non-linearly with an increase in the degree of speed, velocity, force, energy or power exerted on the movable component or on the actuating device.

16. The apparatus of claim 15 wherein the wherein the degree of the second resistance varies exponentially or geometrically with the degree of speed, velocity, force, energy or power exerted on the movable component or on the actuating device.

17. An exercise apparatus comprising:

first and second manually movable actuating devices, each being interconnected to first and second cables respectively, the first and second cables being directly connected to first and second weight stacks respectively each comprised of first and second sets of one or more individual bodies of weight,

the first and second cables each having first and second downstream portions respectively interconnected to the first and second user selectable sets of the one or more individual bodies of weight and to third and fourth resistance devices respectively, the first and second sets of one or more individual bodies of weight exerting first and second resistances respectively and the third and fourth resistance devices exerting third and fourth resistances,

the first and second manually movable actuating devices being respectively interconnected to first and second proximal ends of the first and second cables, the first and second actuating devices being manually movable by the user to exert first and second exercise speeds, velocities, forces, energies or powers respectively through the first and second cables to the first and second downstream portions of first and second cables, the first and second downstream portions of the cables respectively pulling directly against the weight of the first and second sets of one or more individual bodies of weight and against the third and fourth resistance devices,

the third and fourth resistances exerted by the third and fourth resistance devices each respectively increasing

non-linearly with an increase in the degree of speed, velocity, force, energy or power exerted on the first and second manually movable actuating devices or on the third and fourth resistance devices by the user.

**18.** The apparatus of claim **17** wherein movement of the first and second manually movable actuating devices by a user effects mechanical movement respectively of third and fourth movable components of the third and fourth resistance devices that respectively increases the degree of the third and fourth resistances non-linearly with the degree of increase in speed or velocity of movement exerted on the movable component of the third and fourth resistance devices or the first and second actuating devices respectively.

**19.** The apparatus of claim **17** wherein the degree of the third and fourth resistances varies geometrically or exponentially with the degree of exercise speed, velocity, force, energy or power exerted on the first and second actuating device or the third and fourth resistance devices.

**20.** The apparatus of claim **17** wherein the third and fourth resistance devices comprise third and fourth wheels respectively each having a drivably rotatable axle interconnected to one or more blades that forcibly engage against air on rotation of the axle, the third and fourth wheels being interconnected respectively to the first and second downstream portions of the first and second cables respectively in an arrangement wherein the axles of the third and fourth

wheels are rotatably driven by the exercise speed, velocity, force, energy or power exerted by the user on the first and second actuating devices.

**21.** The apparatus of claim **20** wherein the axles of the wheels are spring-load biased against rotation by the exercise speed, velocity, force, energy or power exerted by the user on the first and second actuating devices.

**22.** The apparatus of claim **20** wherein the degree of the third and fourth resistances varies non-linearly with the speed of rotation of the third and fourth wheels.

**23.** The apparatus of claim **20** wherein the degree of the third and fourth resistances varies exponentially or geometrically with the speed of rotation of the third and fourth wheels respectively.

**24.** The apparatus of claim **17** wherein the first and second manually movable actuating devices each comprises a handle each being interconnected to a pivotable lever or a wheel that is interconnected to the first and second proximal ends of the first and second cables respectively.

**25.** The apparatus of claim **20** wherein the first and second downstream portions of the first and second cables are directly connected to first and second manifolds respectively that are directly connectable to a selectable number of the individual bodies of weight of the first and second sets of individual bodies of weight respectively.

**26.** A method of performing an exercise by a user comprising the user's selectively exerting a pulling or pushing force on one or the other or both of the manually movable actuating devices of the apparatus of claim **17**.

\* \* \* \* \*