

[54] PROGRAMMED ARTICLE DISPENSING APPARATUS

[76] Inventor: Joseph Denman Shaw, 508 Church St., Brownsville, Pa. 15417

[22] Filed: Aug. 20, 1973

[21] Appl. No.: 390,063

[52] U.S. Cl. 221/5, 221/94

[51] Int. Cl. B65g 1/00

[58] Field of Search 221/4, 5, 65, 87, 92, 94, 221/225, 238, 287, 126, 131

[56] References Cited
UNITED STATES PATENTS

3,752,359 8/1973 Shaw 221/5

Primary Examiner—Stanley H. Tollberg
Attorney, Agent, or Firm—Walter S. Murray

[57] ABSTRACT

An apparatus including a cabinet containing a plurality of dispensing units and each unit having a number of article containing bins therein. Each bin is coded to dispense an article or articles therefrom when the cabinet is associated with an indexed decoding means. The coding means for each bin is a row of vertical cells that receive axially movable coding pins, said bin and its cells being normally closed by a releasable cover that is opened when the decoding means moves a coding pin against it which signals the operator that an article or articles in that opened bin are to be dispensed.

8 Claims, 14 Drawing Figures

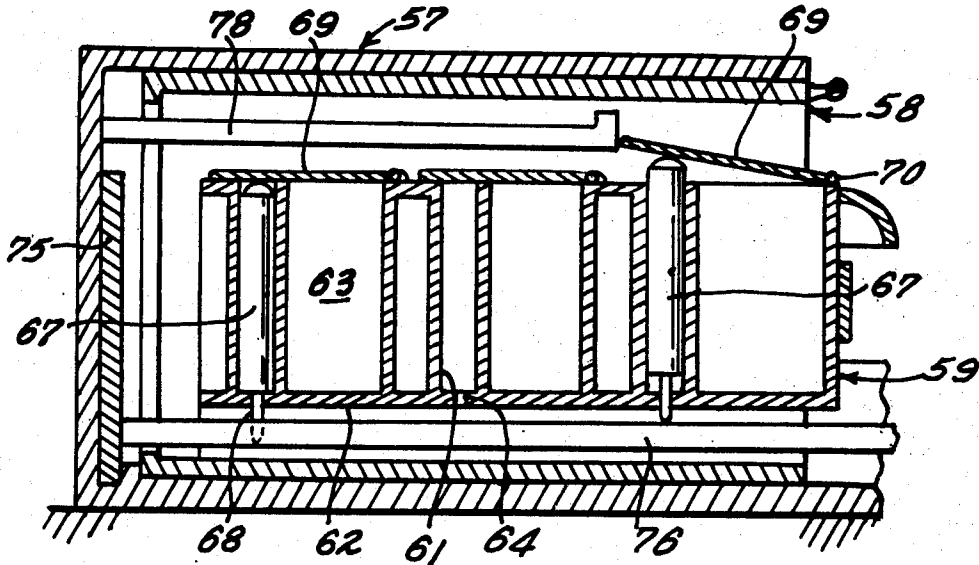

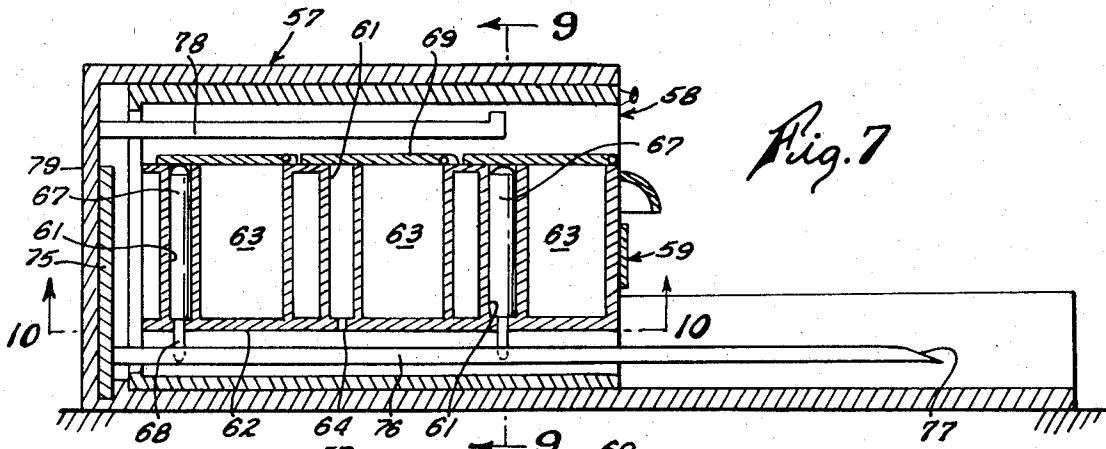

Fig. 7

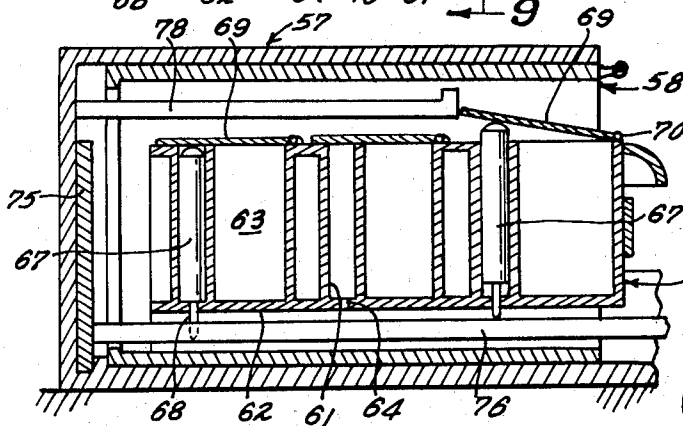

Fig. 8

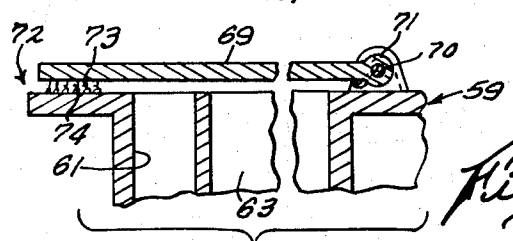

Fig. 11

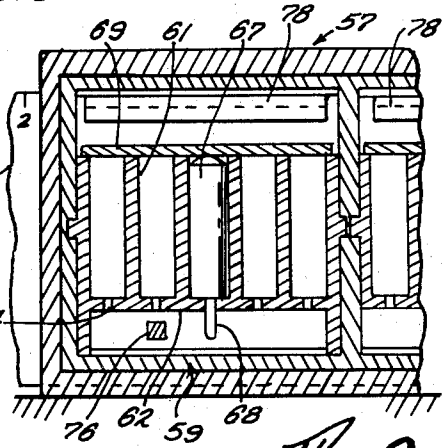

Fig. 9

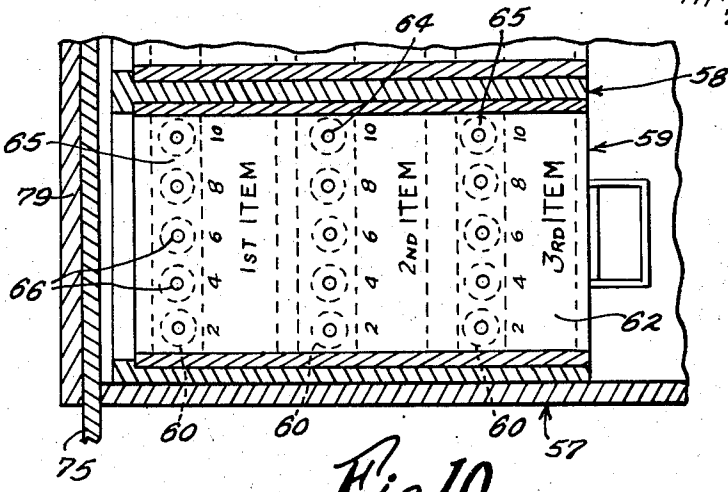

Fig. 10

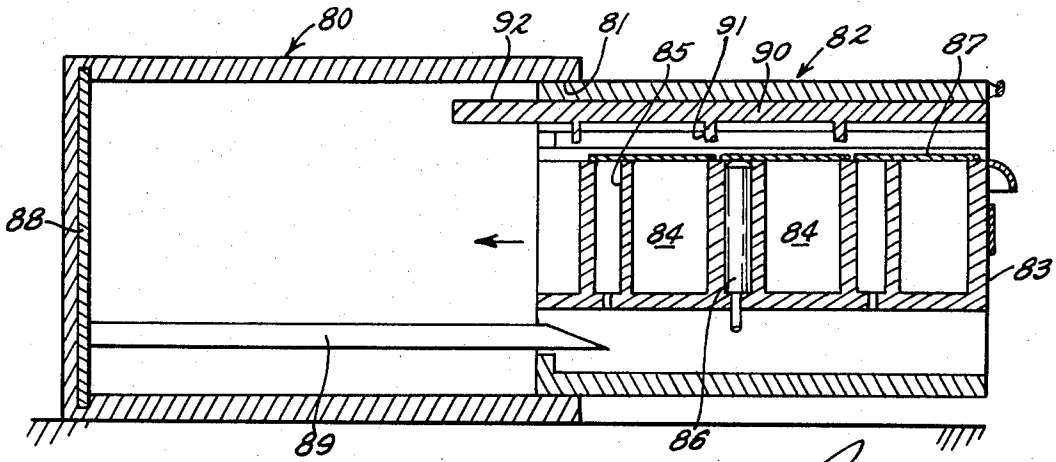

Fig. 12

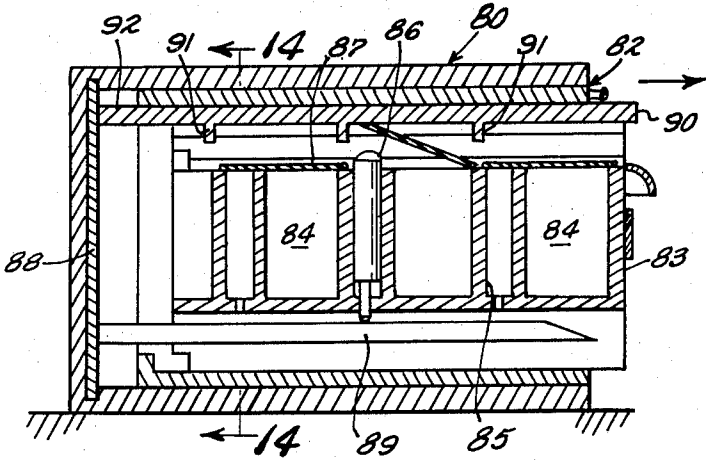

Fig. 13

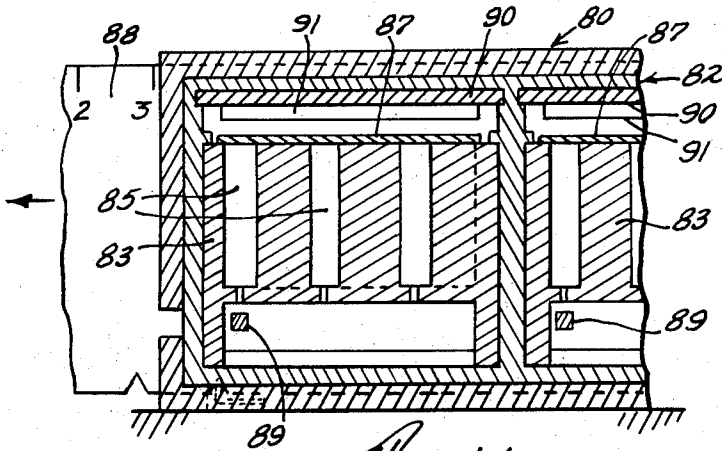

Fig. 14

PROGRAMMED ARTICLE DISPENSING APPARATUS

The present invention relates to article dispensers and is particularly concerned with a programmed apparatus which has a novel coding and decoding means adapted to trip individual signal means at predetermined selected intervals to designate the dispensation of an article or articles from the apparatus.

An object of the invention is to provide a number of dispensing units each having article containing bins therein, a row of upstanding coding pin receiving cells being disposed beside each bin, and releasable cover plates hinged on each unit and each cover plate adapted to normally close a bin and its row of cells. The units are decoded for dispensation of an article or articles by an indexed selector adapted to operate certain coding pins which release associated covers as a signal means that dispensation of an article or articles from a unit is required.

A further object of the invention is to provide in a dispenser having a foregoing characteristic a mechanical signal means operative to slide a unit or units containing the decoded article bins into dispensing positions.

In accordance with my invention and the objects enumerated above, I provide a programmed article dispenser that includes a cabinet containing a plurality of dispensing units preferably in the form of drawers, each drawer having longitudinally spaced apart, article holding bins; a lateral row of upstanding coding cells being disposed beside each bin. Coding pins are placed in predetermined cells for axial movement therein and a releasable cover plate is associated with each bin and its row of coding cells, said cover plate being normally in closed condition. A decoding case having a laterally indexed selector is adapted to periodically receive the cabinet and its pin coded drawers, said selector having a series of pin camming fingers, one for each drawer, which selectively engage and operate certain coding pins to axially move said certain pins that trip and release the cover plate, the released or opened cover plate serving as a signal means that an uncovered bin or bins of a particular drawer contains an article or articles to be dispensed at that period. In a modified form of my invention the signal means is operative to move the selected drawer partially out of the cabinet to positively designate that an article or articles in that drawer are to be dispensed.

Other objects and advantages of the invention will become apparent from the following specification taken in conjunction with the accompanying drawings, wherein:

FIG. 1 is a perspective view of my programmed article dispenser shown in coded, non-dispensing condition.

FIG. 2 is a central section through the programmed article dispenser shown in FIG. 1 but in a decoded condition.

FIG. 3 is a section taken on line 3—3 of FIG. 2.

FIG. 4 is a bottom plan view of one of the slidable dispensing units for the apparatus shown in FIGS. 1—3 of the drawings.

FIG. 5 is a top plan view of the dispensing unit shown in FIG. 4.

FIG. 6 is an enlarged, fragmental section taken on line 6—6 of FIG. 5.

FIG. 7 is a central section like FIG. 2 showing a modified form of my invention in a decoded but non-dispensing condition.

FIG. 8 is a fragmental section like FIG. 7 showing the apparatus in a decoded dispensing condition.

FIG. 9 is a section taken on line 9—9 of FIG. 7.

FIG. 10 is a section taken on line 10—10 of FIG. 7.

FIG. 11 is an enlarged, fragmental view showing a detail of my invention.

FIG. 12 is a central section showing a further modification of my invention in a coded but non-dispensing condition.

FIG. 13 is a section like FIG. 12 showing the apparatus in a decoded condition.

FIG. 14 is a section taken on line 14—14 of FIG. 13.

With particular reference to FIGS. 1—6 of the drawings my programmed article dispenser comprises a cabinet 19 having a top wall 20 a bottom wall 21 and side walls 22—23 enclosing a number of side-by-side compartments 23 which are all open at the front and closed at the rear by a common back wall 24. Each compartment slidably receives a dispensing unit 25 and as all the units are identical in structure and function only one will be hereinafter described in detail.

Each unit 25 has a front wall 26, side walls 27 and 28 and a bottom wall 29 joined to the front and side walls in vertical spaced relation with respect to the bottom wall 21 of the cabinet 19. A number of longitudinally spaced apart item or article holding bins 30 are formed in the unit by upstanding lateral walls 31 and each bin has a lateral row of cells 32 disposed along side it and formed in the adjacent lateral wall 31. As best shown in FIG. 4 the cells are preferably square in section and each is adapted to freely receive a cylindrical coding pin 33. Each cell is provided with a centrally located hole 38 which is formed through the bottom 29 of the unit, said hole being adapted to receive a reduced end 39 of a coding pin 33, said reduced end depending from the bottom 29 of the unit into the space between said bottom and the bottom wall 21 of the cabinet.

As best illustrated in FIG. 4 of the drawings all the lateral rows of holes 38 are calibrated to represent time periods of a day while each lateral row of holes is numbered from back to front of the bottom 29 as Item Nos. 1, 2 and 3. To program any particular dispensing unit 25, coding pins 33 are dropped into the cells represented by the calibrations on the bottom 29 of the said unit, for example, as shown in FIG. 4, the unit is programmed to dispense Item No. 2 at say 4 o'clock Item No. 1 at 6 o'clock and Item No. 3 at 10 o'clock from their respective bins. The coding of the slidable units in time - item relationships is for illustration only, it being understood that the slidable units 25 could be calibrated with other sets of variables such as for different machine parts and particular assembly operations utilizing the parts.

Each row of cells 32 and its associated bin 30 is normally closed by a releasable cover plate 40, each of said plates being pivoted to the top of a lateral wall 31 of the unit as by a piano hinge 41, an expansile coil spring 42 (FIG. 6) being preferably associated with the hinge biasing the cover plate to opened condition. The cover plate is normally held in closed condition against the action of the spring by a separable fastener which takes the form of "Velcro" tape sections having a loop por-

tion 43 secured to the wall 31 of the unit and a cooperative hook portion 44 secured to the underside of the cover plate. Other separable cover plate closure means may be used instead of the "Velcro" tape such as a magnetic latch, or the like.

A decoding case 45 having an open front 46 is adapted to slidably receive the cabinet 20, a selector board 47 being mounted for lateral sliding movement against the rear wall 48 of the case. Unit decoding means in the form of elongated fingers 49, one finger to a unit, are mounted on the selector board 47 and project through a slot 50 (FIG. 2) in the rear wall 24 of the cabinet when the cabinet is slid into the case 45. Each finger 49 has a coding pin camming surface 51 on the free end thereof adapted to engage selected reduced ends 39 on the coding pins 33 of each unit 25.

The selector board is calibrated in the identical time related calibrations along the lateral rows on the bottom 29 of each unit 25 and is adapted to be progressively indexed laterally in the case at intermittent intervals by means of a spring detent means 51. The selector board may be replaced by other boards having different fingers 49 utilizing a slot 52 formed in the side wall 53 of the decoding case. The cabinet 19 has a handle 54 mounted on the front face of the top wall 20 while each unit may have a draw pull 55 on its front wall 26 together with an index card holder 56. It will also be noted that there is a sighting space S (FIG. 2) formed between the top covers 40 of the unit and the inside surface of the top wall 20 of the cabinet 19.

In operation the bins 30 of each dispensing unit 25 are filled with articles or items having the same characteristics, the names of said articles or items appearing on the index card 56 on the front of the particular unit. Next the coding pins 33 are placed in selected cells 32 and the cover plates 40 are then closed by engagement of the respective "Velcro" fasteners, or other separable closure means. All the filled and coded units 25 are then fully slid into the cabinet 19 and at selected times, determined by the indexed position of the selector board 47, the cabinet 19 is pushed into the case 45 and as the cabinet moves into the case the camming surfaces 51 on the selector fingers 49 will contact predetermined reduced ends 39 on the coding pins 33 which move the pins upwardly thus releasing the cover or covers 40 from their fasteners 43-44 and the springs will move the released covers into the open position shown in FIG. 2 of the drawings. As shown in FIG. 2 by sighting through the space S the operator will be apprised of whether a cover 40 has been released and opened and thereafter by means of the hand pull 55 he can pull the unit out of the cabinet and as shown on the cover (FIG. 5) take the proper number of items or article from the bin having the released cover and apply it according to the instructions on said indexed card holder 56.

Now with reference to FIGS. 7-10, inclusive, of the drawings there is depicted a decoding case 57 having an open front adapted to slidably receive a multi-compartmented cabinet 58, said cabinet being adapted to slidably receive in each compartment an item dispensing unit 59. Each dispensing unit has formed therein a number of lateral rows 60 of narrow vertical calls 61. Each dispensing unit is also provided with a bottom wall 62 which forms the bottoms for the cells and for item containing bins 63 formed in each unit ad-

5 adjacent each row of cells. A hole 64 is formed through the wall 62 centrally of each cell 61, and as shown in FIG. 10, the holes are arranged in lateral rows 65 and calibrated, for example, to represent time periods of the day while the rows 66 are longitudinally spaced apart to represent, for example, different items. To program each dispensing unit pin means in the form of a cylindrical element 67 having a reduced end 68 is inserted into the proper cells 61, the ends extending through the holes 64 into the space between the wall 62 and the opposed bottom surface of the compartment. As best shown in FIG. 8, each row 60 of cells and its adjoining bin 63 is normally closed by a cover plate 69, hinged to the dispenser body at 70 (FIG. 11) and biased to opened position by a spring 71 associated with the hinge. The plate is normally held in closed position by a separable latch means 72 in the form of a conventional "Velcro" fastener or magnetic latch or other separable latching means, which has loop means 73 secured to the plate and cooperable hook means 74 secured to the dispensing unit body 59.

The case has, for example, a time relates selector 75 mounted in the rear thereof for lateral sliding movement, said selector having a lateral row of fingers 76, one to a dispensing unit, mounted thereon for projection into the space between the wall 62 of each unit and the opposed bottom surface of the cabinet. Each finger 76 has a tapered terminal end 77 (FIG. 7) adapted to engage, at selected times, the end of a lug 68 in its path and to cam said lug upwardly, thus moving the pin means 67 upwardly to overcome latch means 72 and release the cover plate 69 (FIG. 8) thus moving the latter to an opened position.

A pusher bar 78 is mounted on the rear wall 79 of the case and extends forwardly into the cabinet above the dispensing unit a distance short of the length of the finger 76; said pusher bar having a lateral dimension substantial the width of each dispensing unit (FIG. 9).

In the operation of the device illustrated in FIGS. 7-11 of the drawings, each dispensing unit is item-coded by inserting pin means 67 in selected cells 61, the adjacent bins 63 filled with articles to be dispensed and all the cover plates 69 closed. Then the proper time selector 75 is slid into the case 57 and at predetermined times the cabinet 58 and its coded dispensing units 59 are slid into the decoding case. In the event nothing is to be dispensed from a particular unit 59, its finger 76 will not engage a pin means 68 (FIG. 7) and the unit will remain closed within the cabinet. However, if, for example, Item No. 3 is to be dispensed from the unit at that time the finger 76 will first cam the pin means 67 upwardly (FIG. 8) thus releasing the fastening means 72 of the cover plate 69 and permitting the plate to open under the bias of its spring 71. This action causes the plate to come into contact with the pusher 78 which will, upon further movement of the cabinet 58 to its home position within the decoding case 57, move the dispensing unit from the cabinet whereafter the proper Item No. 3 may be removed from the opened bin for dispensation.

Another modification of my invention is shown in FIGS. 12-14 of the drawings wherein the reference numeral 80 is a decoding case having an open front 81 that slidably receives a multi-compartmented cabinet 82. A dispensing unit 83 is slidable in each compartment and, as in the previously described units, each unit has a number of longitudinally spaced bins 84 and

each bin has a lateral row of cells 85 beside it to receive axially movable coding pins 86. Each bin and row of cells are closed by a common cover plate 87 hinged to the unit and biased to opened position by a spring means (not shown), said cover plate being held in closed position by a releasable fastener means, as in the previously described modifications.

The decoding case also has a selector board 88 mounted for intermittent lateral sliding movement in the rear of the case, said board having a number of decoding fingers 89 mounted thereon, one to a unit.

This modified programmed dispenser differs from the two previously described modifications in that a unit pusher 90 is mounted for sliding movement in the cabinet 82 above and independently of each unit 83, said board having lugs 91 depending from it into the paths of the opened but not the closed cover plates 87. The pusher also has a bar portion 92 on the rear thereof which normally extends rearwardly beyond the cabinet 82.

Now as the cabinet 82 is pushed into the case 80 the decoding fingers 89 will move certain of the pins 86 upwardly which releases a lid or lids 87. As the cabinet is further inserted into the case the bar 92 on the unit pusher 90 will engage the selector board 88 whereby the lugs 91 on the pusher will be engaged by the opened cover plates 87 and stop the unit 83 while the cabinet 82 continues to its home position which in effect moves the unit beyond the cabinet thereby signaling that a cover plate on a bin or bins has been opened by the decoding finger 89. Then the unit is pulled out along with the drawer pusher, the item or items dispensed from the proper bins 84 and the cabinet reset.

Having thus described my invention what I claim as new is:

1. In a programmed article dispenser:
 1. a cabinet containing a number of compartments;
 2. a dispensing unit slidably mounted in each compartment;
 3. a number of longitudinally spaced apart article bins in each unit;
 4. a lateral row of upstanding cells in the unit positioned beside each bin;
 5. a common cover plate hinged on the unit for association with each lateral row of cells and the adjacent bin;
 6. releasable means normally holding the cover plate in closed position on each bin and its row of cells;
 7. coding pins each disposed for axial movement in a predetermined cell;
 8. a decoding case adapted to slidably receive the cabinet;
 9. an indexed selector mounted for intermittent lateral movement in the case;
 10. a unit decoding means positioned on a major face of the selector, and
 11. cooperative means on the unit decoding means and on the coding pin of each unit adapted to move the pin to release the cover as the cabinet is slid into the case thereby placing the unit in condition

for dispensation of selected articles from the bins.

2. A programmed article dispenser set forth in claim 1 wherein each cell has a bottom wall, said wall having a hole formed therethrough, and the coding pins have reduced ends which extend through the holes to form the cooperative means thereon with the decoding means on the selector.

3. A programmed article dispenser set forth in claim 2 wherein the unit decoding means is a finger projecting from the selector beneath the dispensing unit, the end of said finger having a camming surface to form a cooperative means with the reduced ends of the coding pins.

4. A programmed article dispenser as set forth in claim 3 wherein the cover is biased to open condition, and the releasable means is a separable fastener disposed between the cover and the dispensing unit.

5. A programmed article dispenser set forth in claim 1 wherein the cells in each row are time related and the rows are item related.

6. In a programmed article dispenser:

1. a cabinet containing a number of compartments;
2. a dispensing unit slidably mounted in each compartment;
3. a number of longitudinally spaced apart article bins in each unit;
4. a lateral row of upstanding cells in the unit beside each bin;
5. a common cover hinged on the unit for association with a lateral row of cells and an adjacent bin;
6. releasable means normally holding the cover in closed position on each bin and row of cells;
7. coding means each disposed for axial movement in predetermined cells;
8. a decoding case adapted to slidably receive the cabinet;
9. a selector mounted for intermittent lateral movement in the case;
10. a unit decoding means positioned on the major face of the selector;
11. cooperative means on the decoding means and on the coding pin of each unit adapted to move the pin to release the cover as the cabinet is being slid into the case;
12. and cover engaging stop means associated with the casing and positioned in the path of an opened cover when the cabinet is being slid into the case whereby the unit is slid out of the cabinet as the cabinet approaches its fully inserted position within the case.

7. A programmed article dispenser set forth in claim 6 wherein the stop means is a bar mounted on the casing and extending into the cabinet.

8. A programmed article dispenser set forth in claim 6 wherein the stop means is a plate slidable in the cabinet and having a rear extension engageable against the casing, said plate having a longitudinal series of depending lugs each engageable by a released cover.

* * * * *