

(19)  
(12)

(KR)  
(B1)

(51) 。 Int. Cl. <sup>6</sup>  
H01F 27/08

(45)  
(11)  
(24)

2002 01 04  
10 - 0318670  
2001 12 12

(21) 10 - 1999 - 0019131  
(22) 1999 05 27

(65) 2000 - 0074890  
(43) 2000 12 15

(73)

3 416

(72)

403 205

(74)

:

(54) 가

가 , (12); (12)  
 1, 2 (15a)(15b); (12) (13)  
 (16); . (13)  
 (17) (13) (16)가 ( )  
 12) (13) (12) (12)

가 .

3

, , , , ,

- 1
- 2
- 3
- 4 3
- 5 6

\* \*

- 12 ; 13 ;
- 13a ; E 15a ; 1
- 15b ; 2 16 ;
- 17 ;

가

(high voltage transformer, HVT) 110V 220V

가

(laminated core) ,

1, 2

E I 가 가 . 1

2

1, 2

(Joule損),

98 - 6654

1

(1)

(1a)

(3)

(3)

(General Electric Co.)

914,857

2

E (4)

(4a)(4b)

(4)

E (4)

(4a)가

(5)

가 가

1, 2 ; ;

가

가

가 3 4 3

4

(12) , 1,2 (15a)(15b)

(16)

(12) 4 E (13a) I (13b)가 (13)

. 1, 2 (15a)(15b) E (13a) (14) ,

7) (16) (12) 13

(17) (13) (13) E (13a) (1)

3 4 (16) , 5 6

(17') (17'') 가 ,

(12) 가 3 4

가 , 18

가 (12)가 (13)

(13) 4 (16)가 (12)

(12) 가 , (13) E (13a)

I (13b) E (13a) 가 (14) 1, 2 (15a)(15b)

, 가 가 ,

, 가 가 , 3

, 가 ,

(57)

1.

;

1, 2 ;

; ,

2.

3.

1 , 가

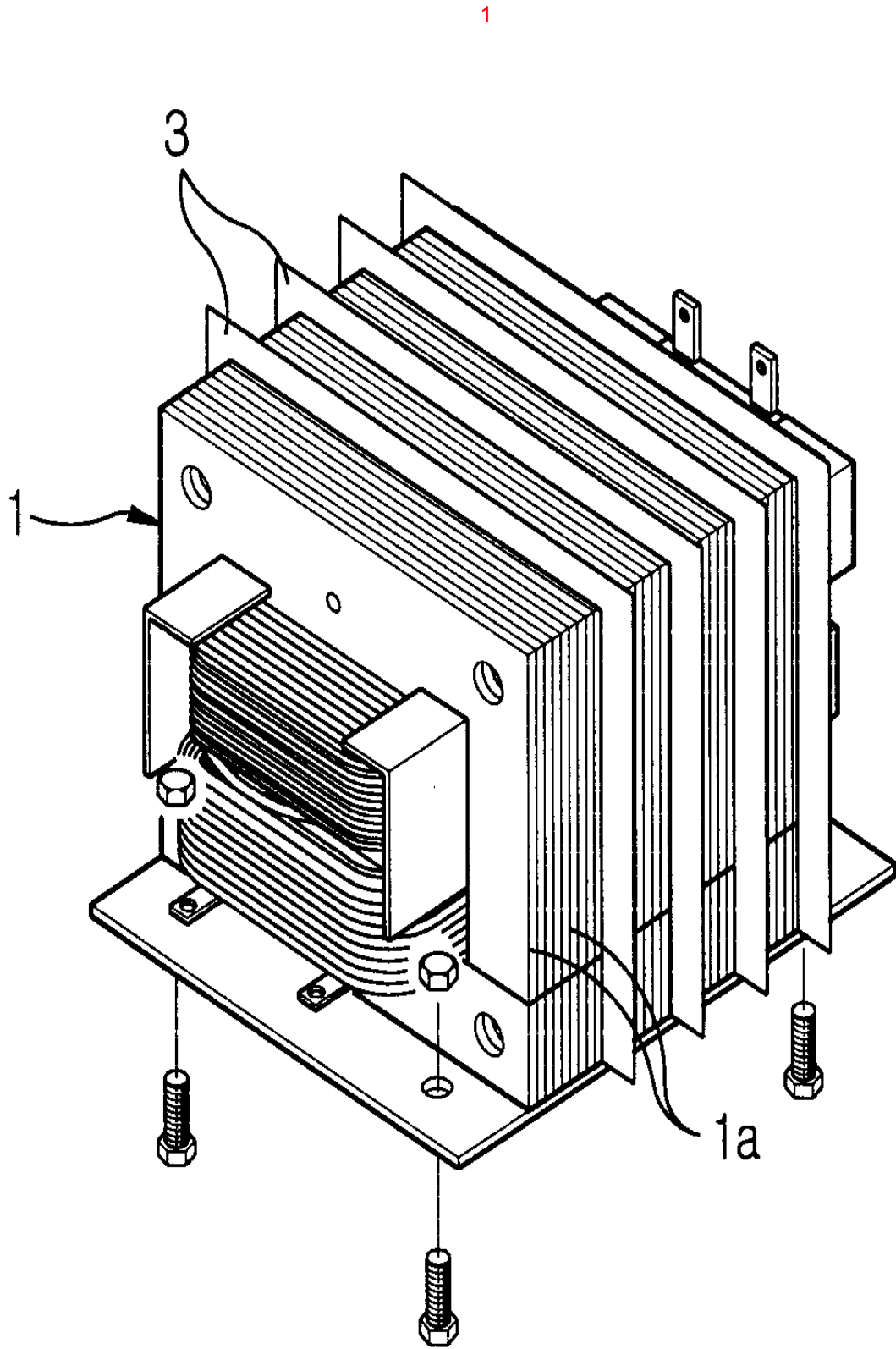

2

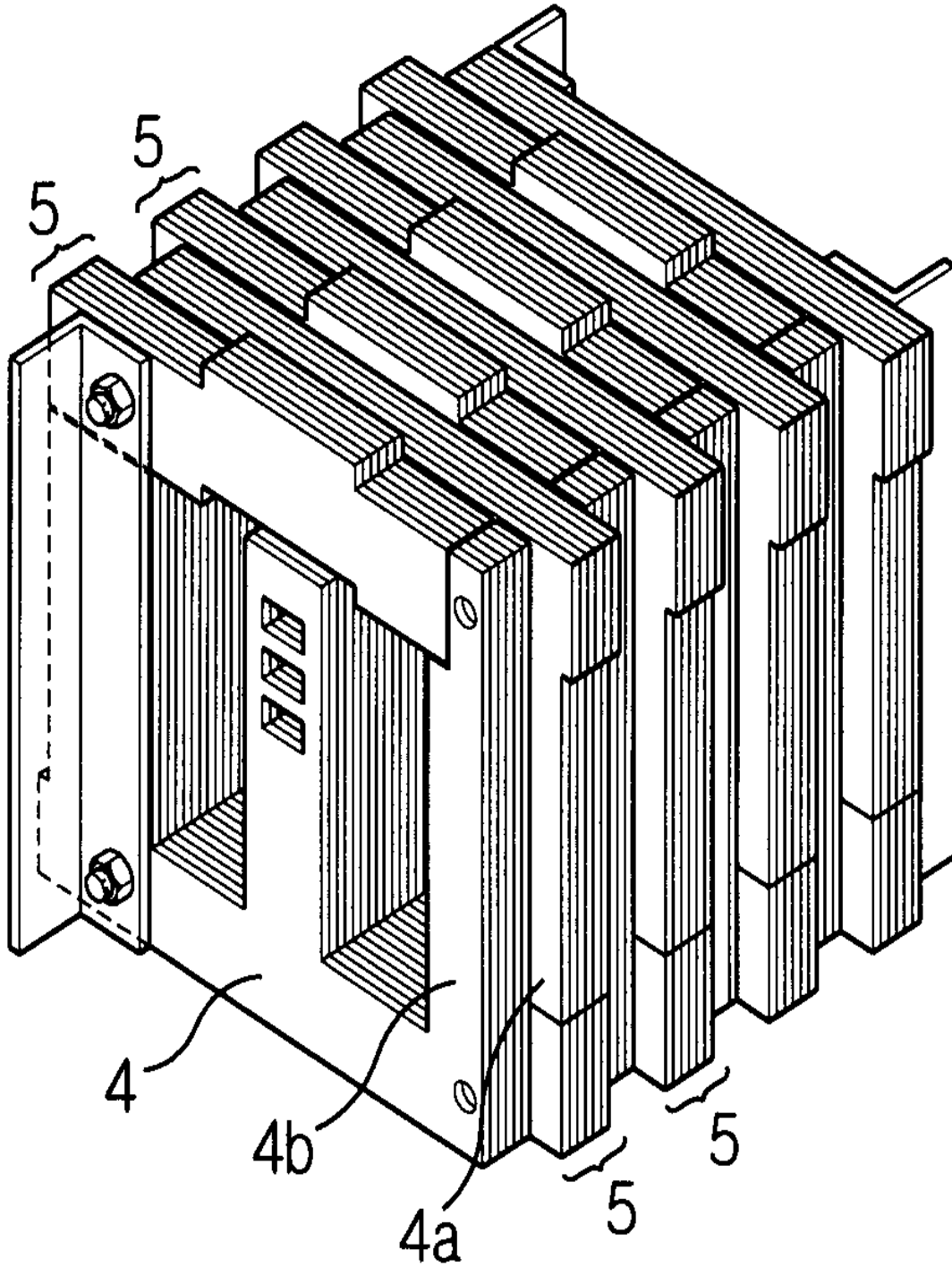

3

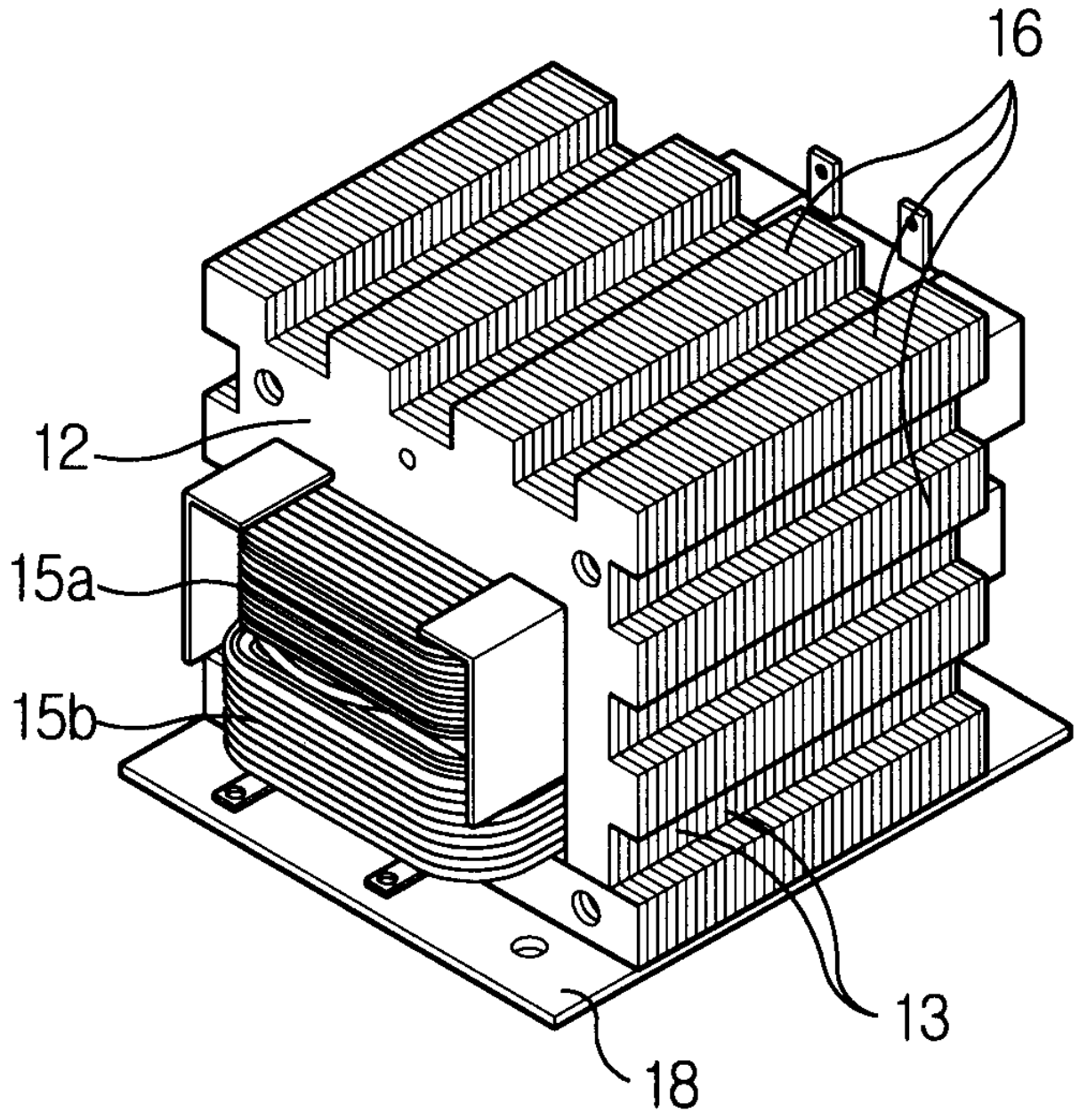

4

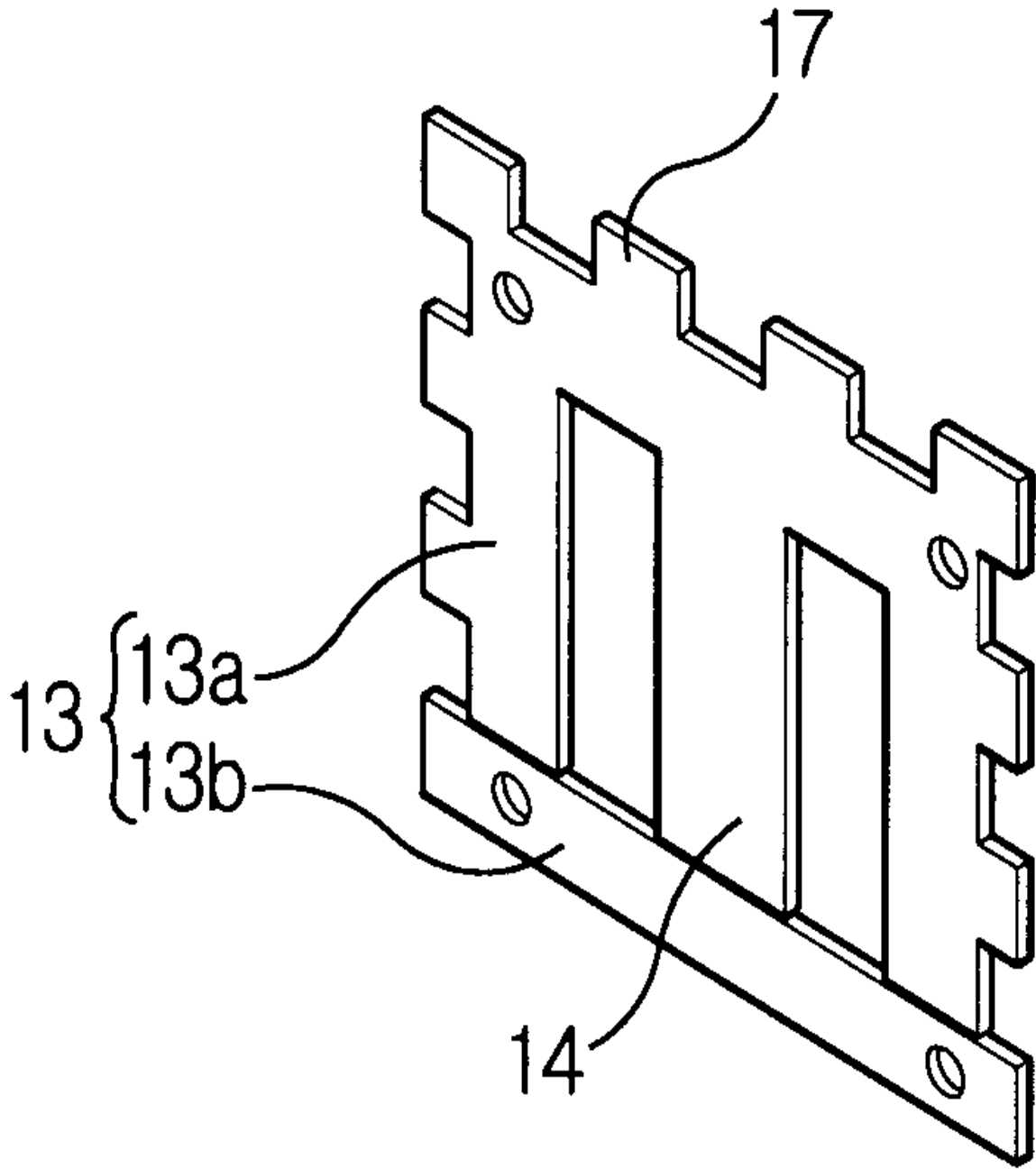



5

17'

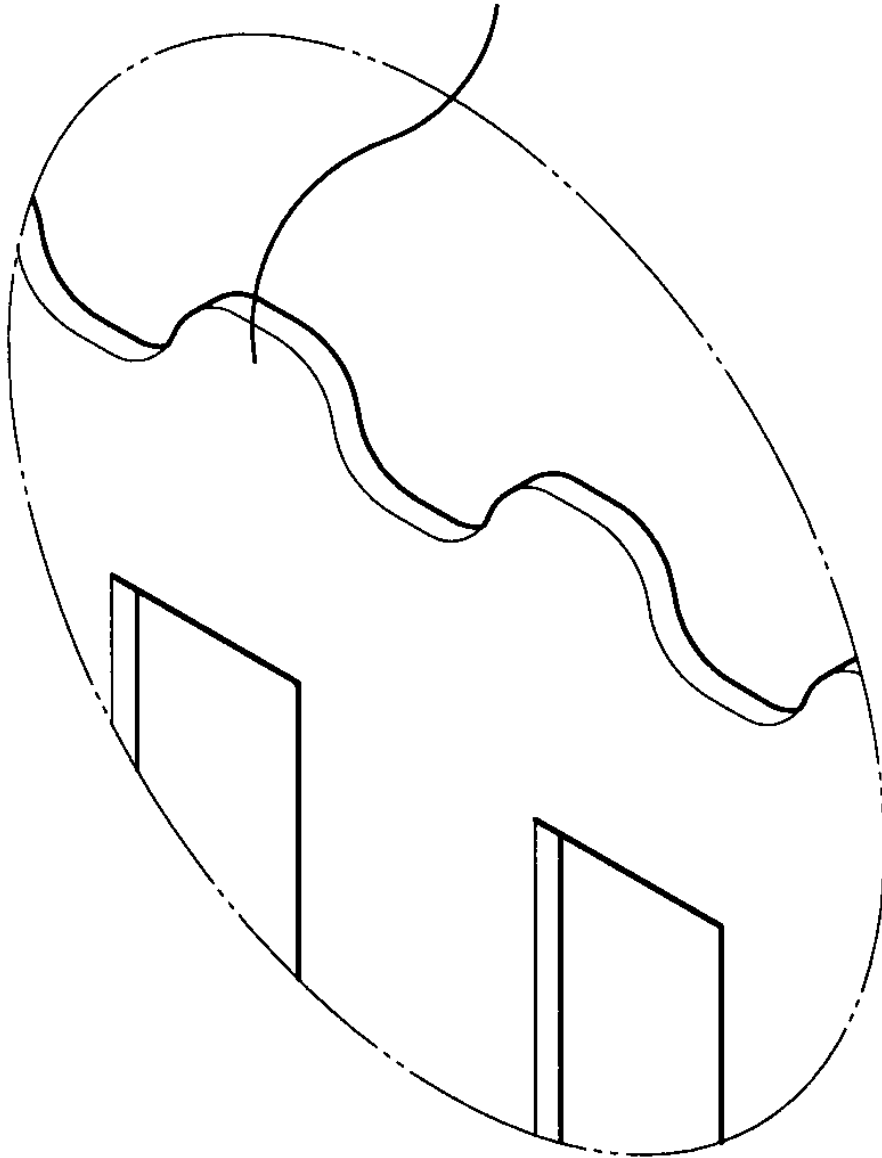

6

