



(19) **United States**

(12) **Patent Application Publication**  
**Merritt et al.**

(10) **Pub. No.: US 2024/0207593 A1**

(43) **Pub. Date: Jun. 27, 2024**

(54) **HEMOSTASIS VALVES AND METHODS OF USE**

(71) Applicant: **Inari Medical, Inc.**, Irvine, CA (US)

(72) Inventors: **Benjamin E. Merritt**, San Clemente, CA (US); **John C. Thress**, Capistrano Beach, CA (US); **Paul Lubock**, Monarch Beach, CA (US)

(21) Appl. No.: **18/598,482**

(22) Filed: **Mar. 7, 2024**

**Related U.S. Application Data**

(63) Continuation of application No. 18/515,079, filed on Nov. 20, 2023, which is a continuation of application No. 17/226,318, filed on Apr. 9, 2021, now Pat. No. 11,844,921, which is a continuation of application No. 16/117,519, filed on Aug. 30, 2018, now Pat. No. 11,000,682.

(60) Provisional application No. 62/554,931, filed on Sep. 6, 2017.

**Publication Classification**

(51) **Int. Cl.**  
*A61M 39/06* (2006.01)  
*A61B 17/3207* (2006.01)  
(52) **U.S. Cl.**  
CPC ..... *A61M 39/0613* (2013.01); *A61B 17/3207* (2013.01); *A61M 2039/062* (2013.01); *A61M 2039/0673* (2013.01)

(57) **ABSTRACT**

Devices, systems, and methods for sealing medical devices, particularly during intravascular access, are disclosed herein. Some aspects relate to a hemostatic valve for sealing a wide range of medical devices, such as catheters, wires, embolectomy systems. The valve can include an elongate member having a first end, a second end, and a central lumen extending therebetween. A reinforcement structure extends along at least a portion of the elongate member and is coupled to the elongate member. A shell defining a first aperture and a second aperture may be included, which first and second apertures can be fluidly coupled by the elongate member. A tensioning mechanism is coupled to the shell and to the elongate member, the tensioning mechanism can be moveable between a first configuration wherein the tensioning mechanism is collapsed and the central lumen is sealed and a second configuration wherein the central lumen is open.

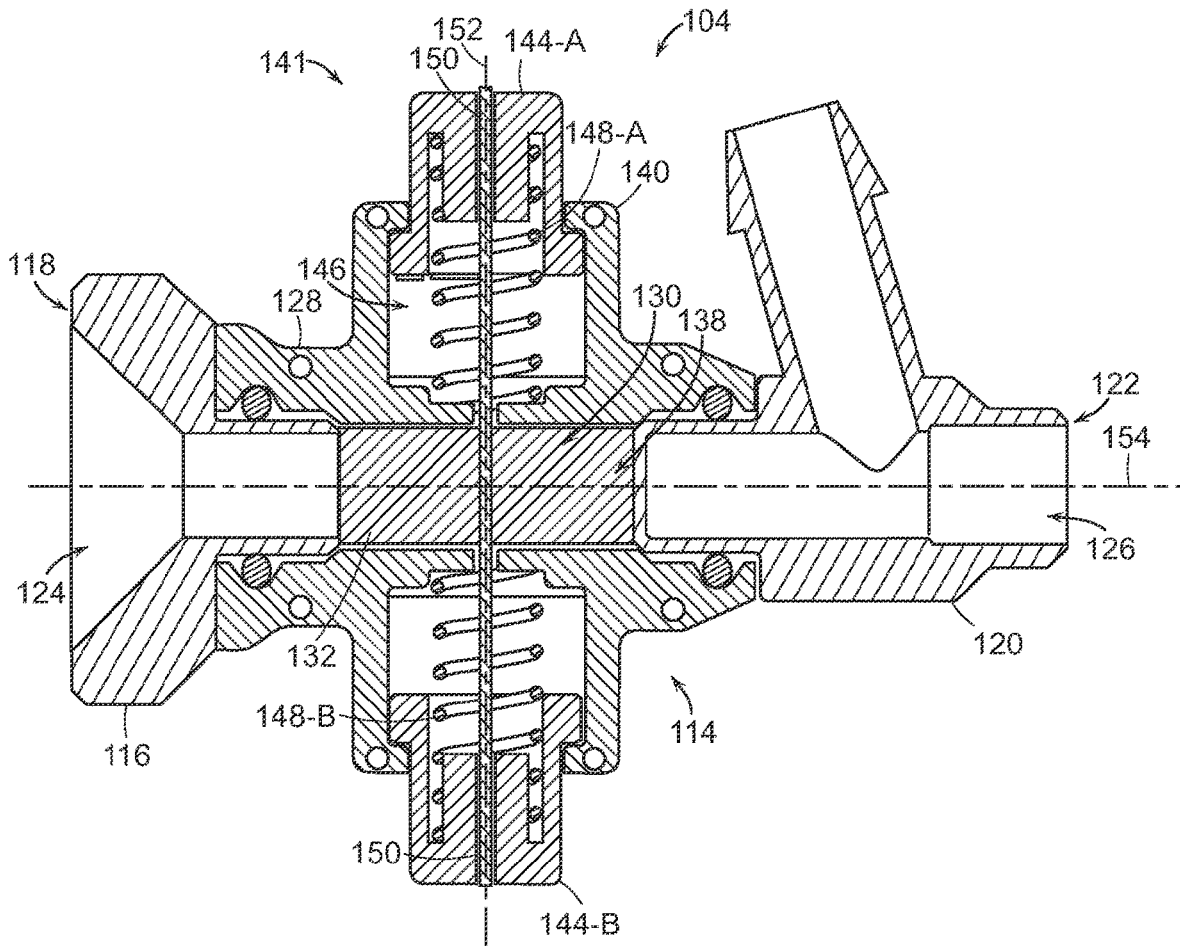

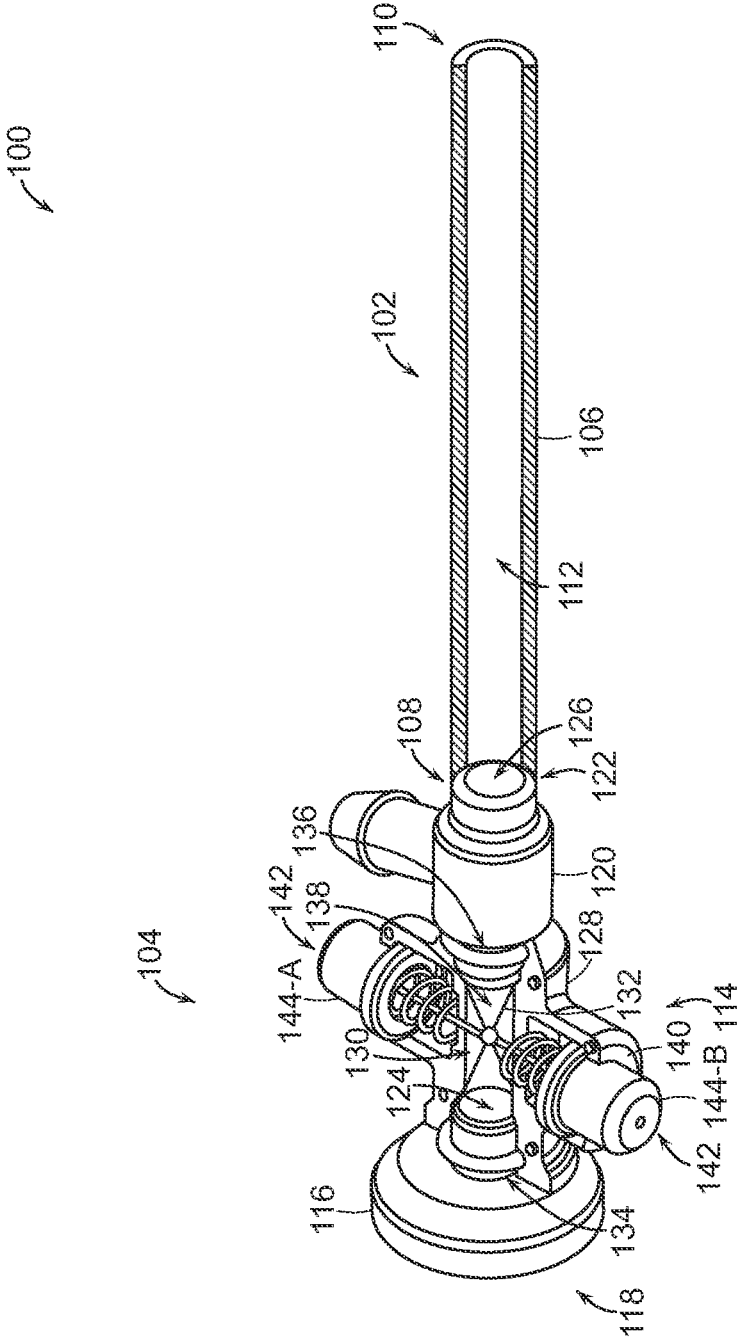

FIG. 1

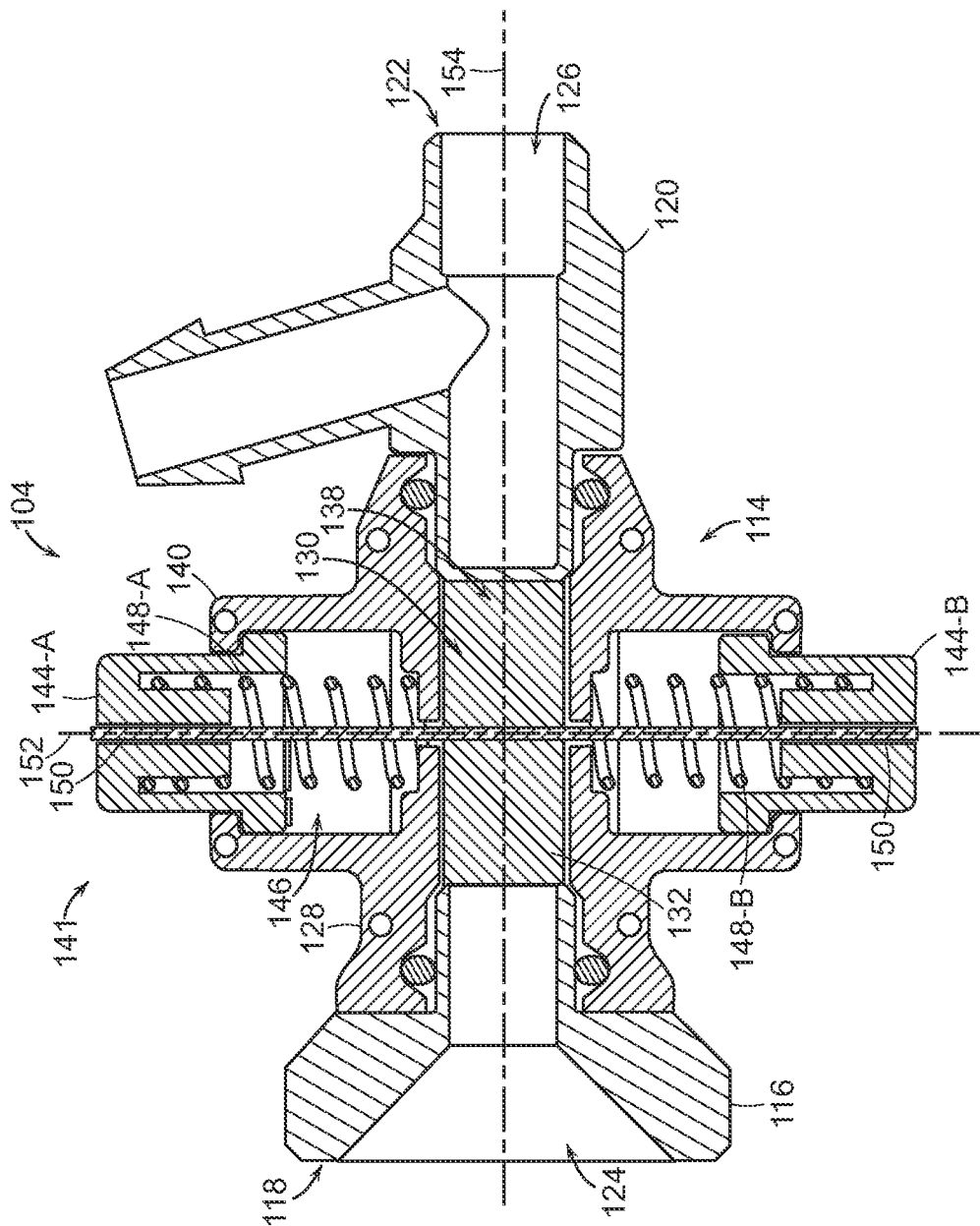

FIG. 2

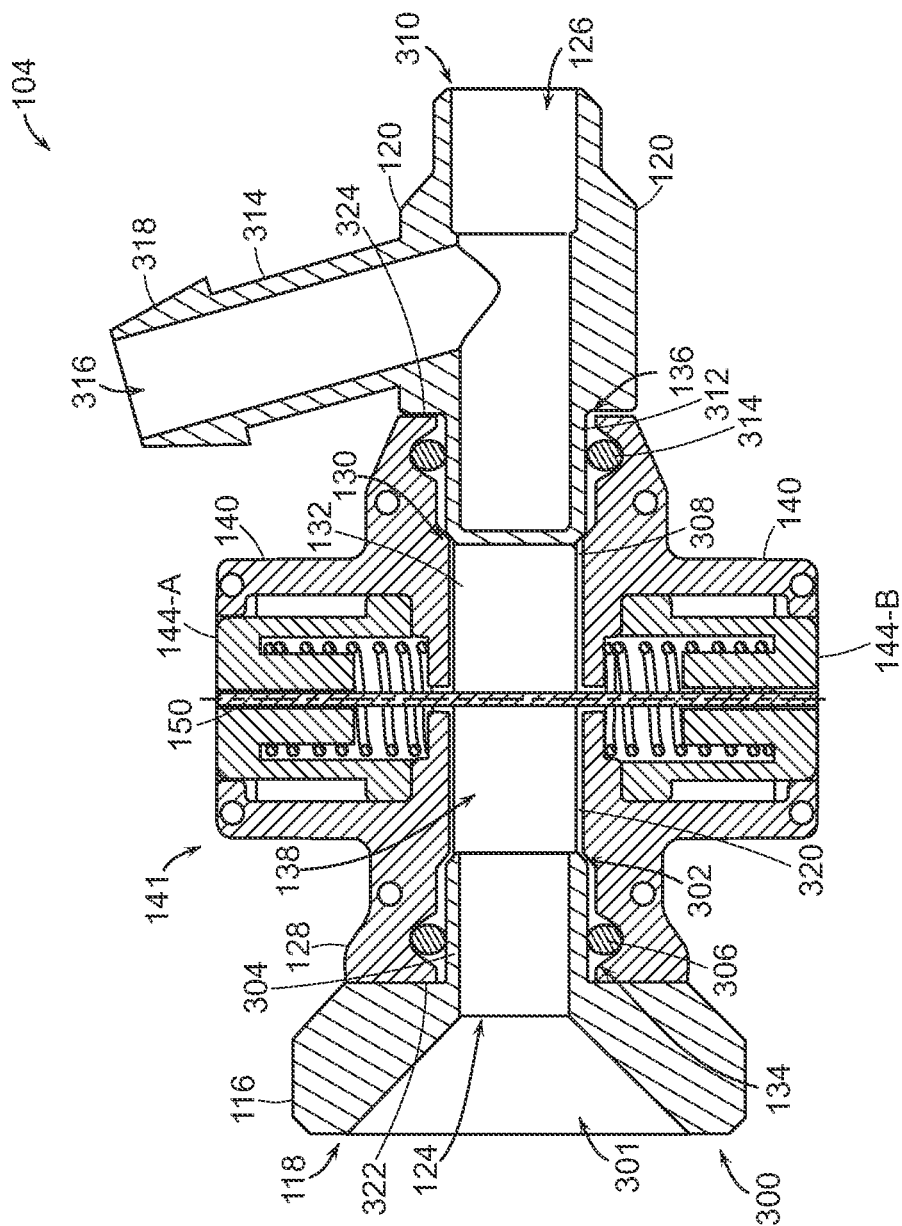

FIG. 3

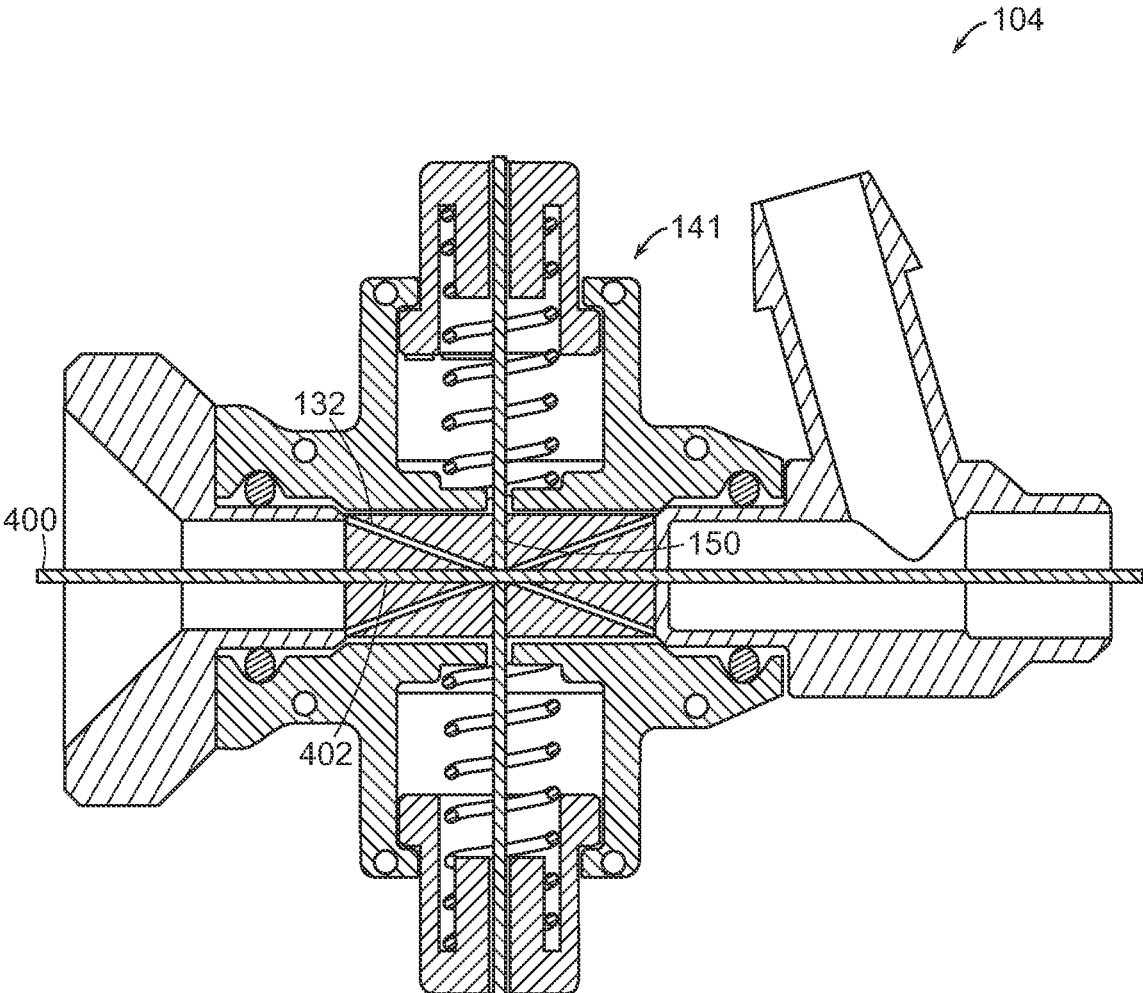

FIG. 4

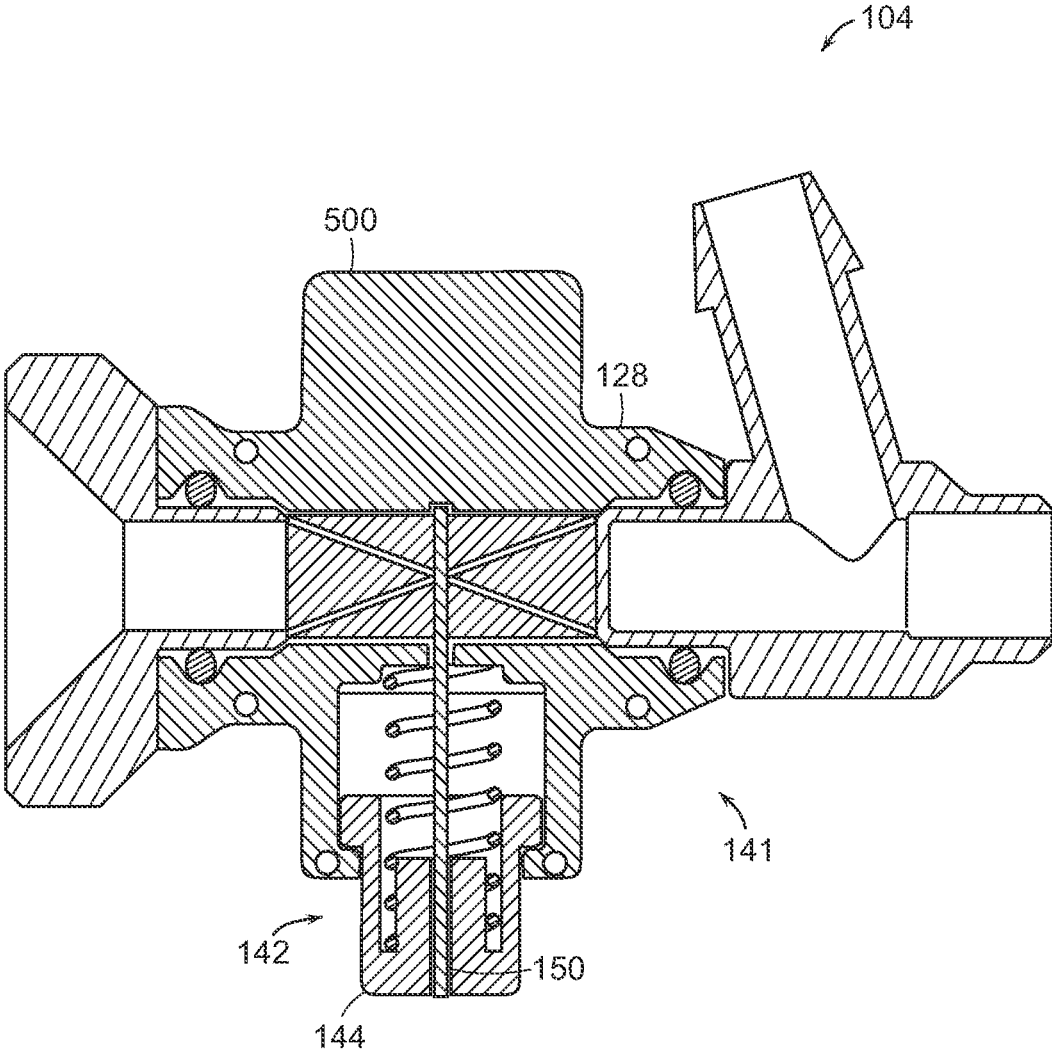

FIG. 5

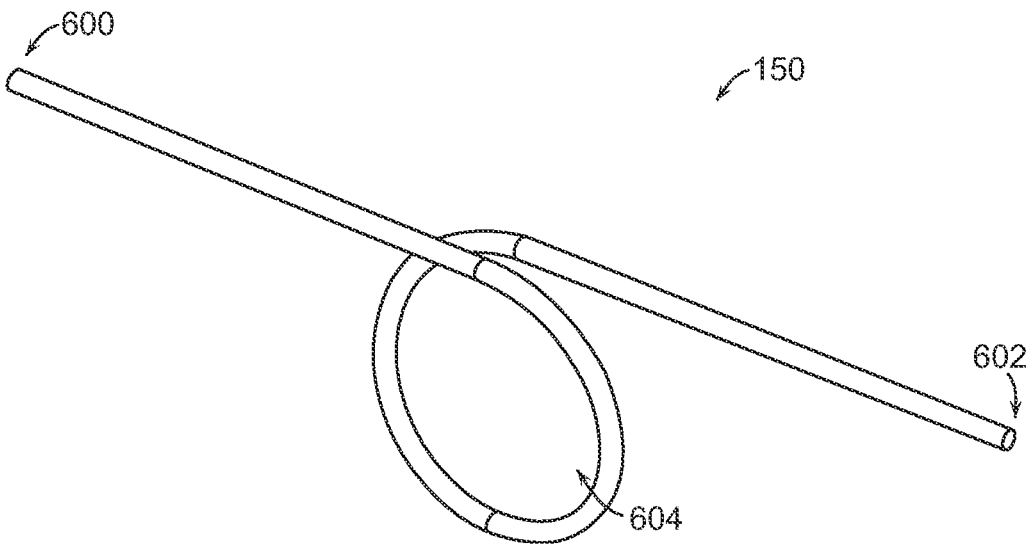

FIG. 6

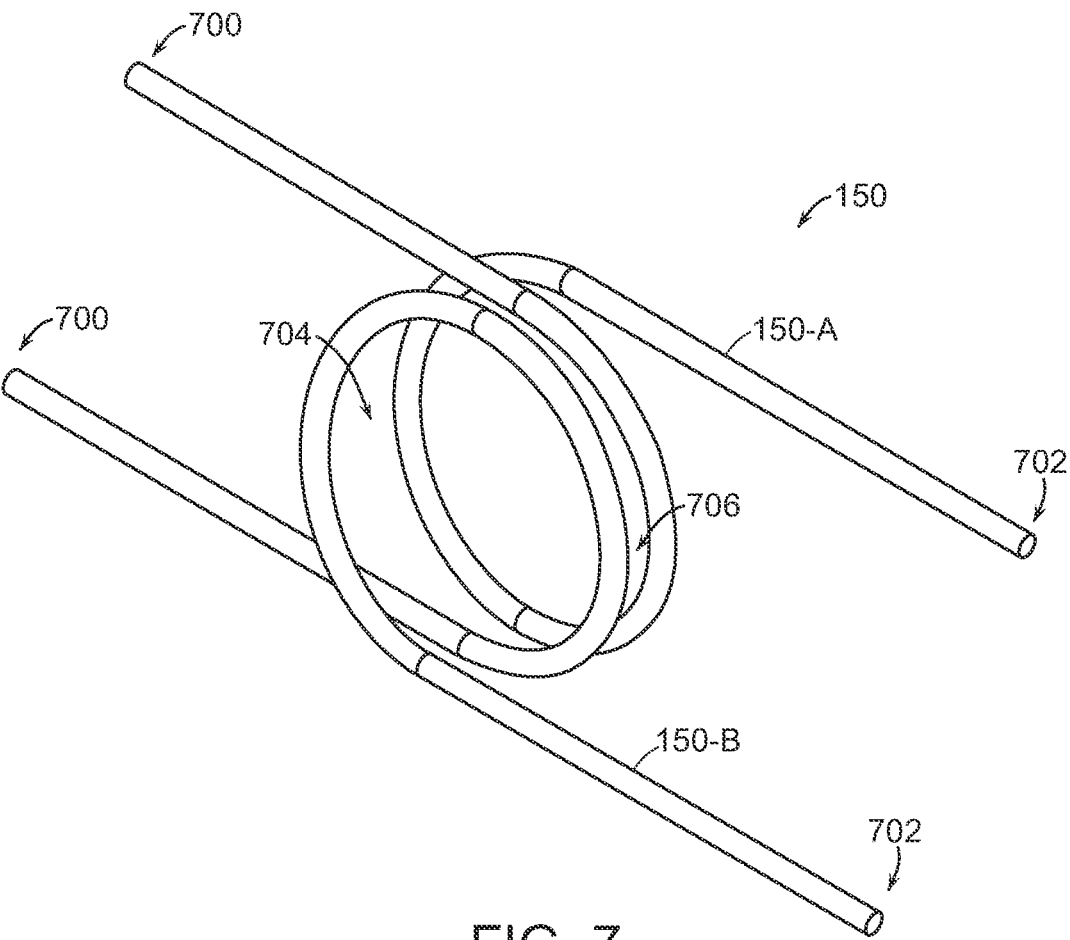

FIG. 7

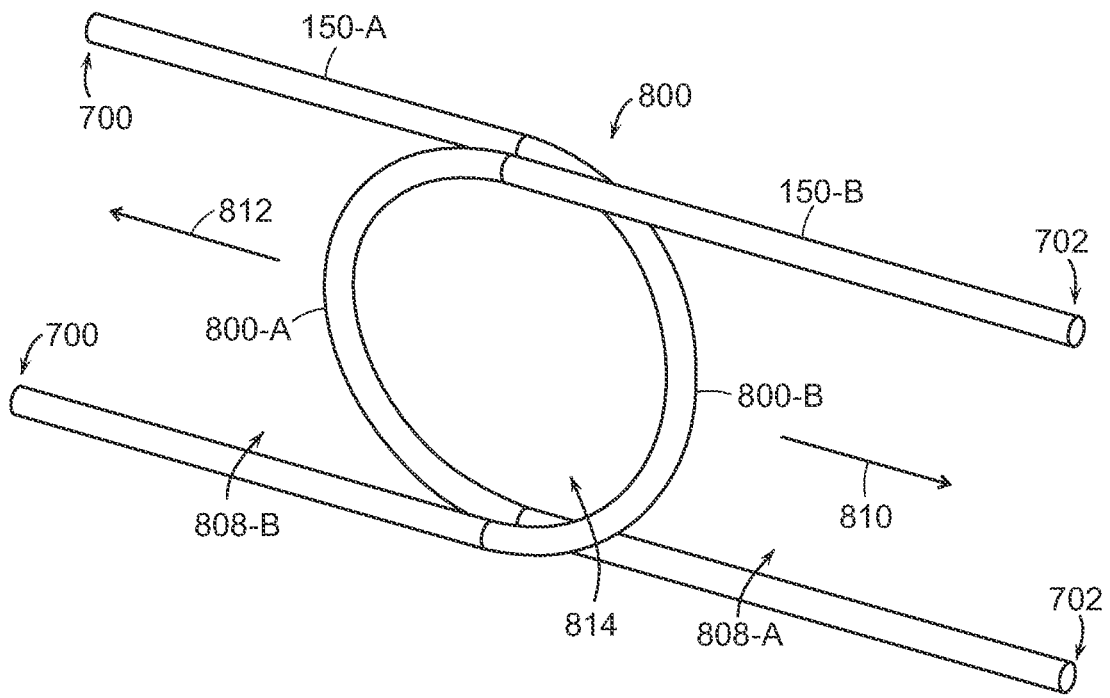

FIG. 8

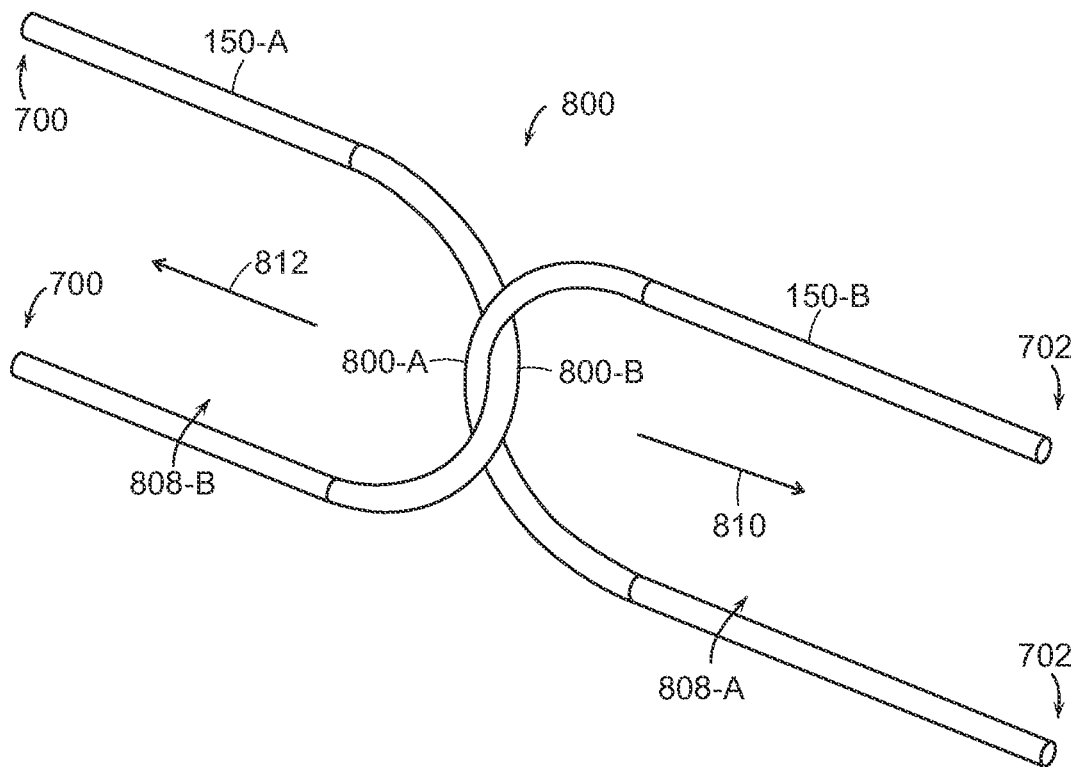

FIG. 9



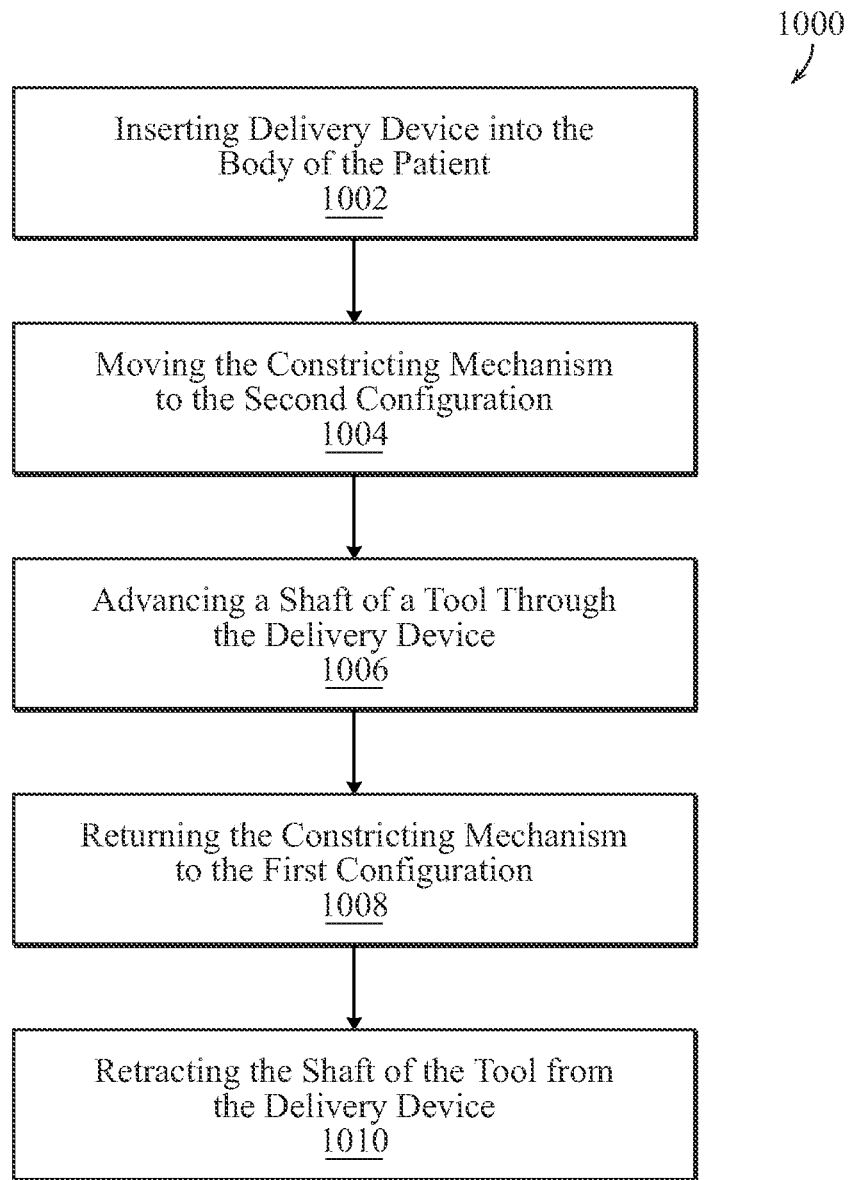

FIG. 10

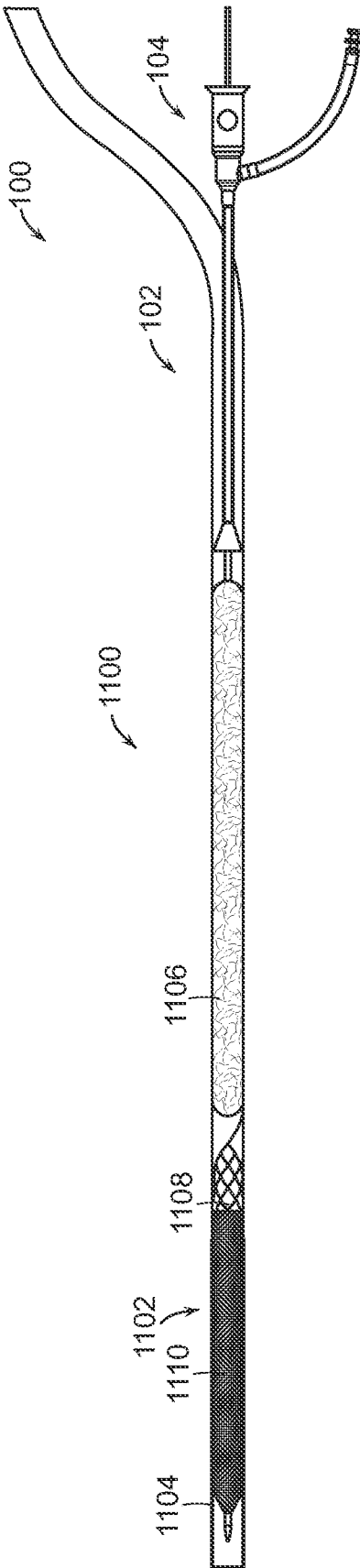

FIG. 11

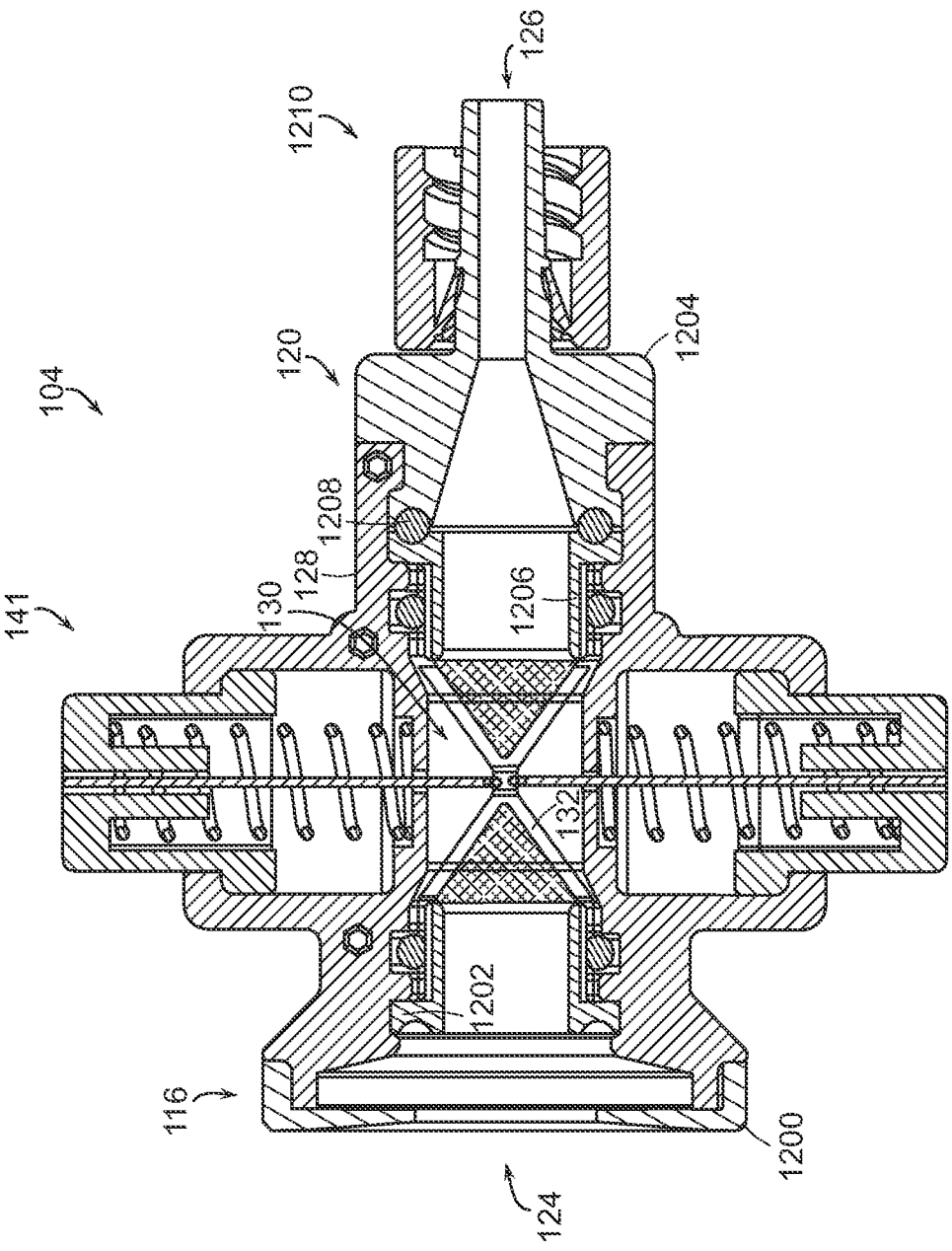

FIG. 12

## HEMOSTASIS VALVES AND METHODS OF USE

### CROSS-REFERENCE TO RELATED APPLICATIONS

[0001] This application is a continuation of U.S. patent application Ser. No. 18/515,079, filed on Nov. 20, 2023, titled “HEMOSTASIS VALVES AND METHODS OF USE,” which is a continuation of U.S. patent application Ser. No. 17/226,318, filed on Apr. 9, 2021, issued as U.S. Pat. No. 11,844,921, and titled “HEMOSTASIS VALVES AND METHODS OF USE,” which is a continuation of U.S. patent application Ser. No. 16/117,519, filed on Aug. 30, 2018, now issued as U.S. Pat. No. 11,000,682, and titled “HEMOSTASIS VALVES AND METHODS OF USE,” which claims the benefit of U.S. Provisional Patent Application No. 62/554,931, filed on Sep. 6, 2017, and titled “HEMOSTASIS VALVES AND METHODS OF USE,” each of which is incorporated by reference herein in its entirety.

### BACKGROUND

[0002] During a surgical procedure, a portion of a patient’s body (e.g., vasculature) is accessed to allow for performance of a desired intervention or treatment. During such surgical procedures, it is desired to minimize patient blood loss, prevent delivery of air into the vasculature, and to maintain the sterility of the accessed portions or sites of the patient’s body so as to prevent issues such as infection. Further, the desire for improved patient outcomes has led to the development of hemostasis valves that facilitate minimally invasive surgery.

[0003] In minimally invasive surgery, small incisions are created through a blood vessel which one or several catheters are inserted. Each of these one or several catheters can define a lumen extending longitudinally through that catheter. These catheters are moved to a position proximate to tissue, nerves, or other body structures targeted by the surgery, and then tools for performing the procedure are inserted through the lumens of some or all of these catheters.

[0004] To minimize blood loss, prevent delivery of air into the vasculature, and to facilitate maintenance of sterility within the patient’s body (e.g., blood vessel), these catheters are equipped with hemostasis valves. These valves seal or selectively seal the lumens of the catheters. In many instances, these valves can seal the lumen of the catheter when a tool extends through the catheter, and specifically through the valve. Additionally the valves can seal the lumen when a tool is removed or does not extend through the catheter.

[0005] While such traditional hemostasis valves are greatly beneficial for intravascular access, they have some drawbacks. For example, some valves may not seal adequately for all interventional applications or tools, and/or the operation of some valves may be complicated for operator use. The drawbacks of such valve designs may in turn increase the complexity of any surgery performed therewith and/or reduce patient safety (e.g., bleeding, infection, and/or other detrimental complications). Accordingly, new and improved hemostasis valves and methods of use are desired.

### SUMMARY

[0006] The following relates to valves, medical systems incorporating valves, and methods of using the same. The valve can include a tubular member that can be constricted, collapsed, and/or sealed by one or several tensioning mechanisms. The tensioning mechanism can include at least one filament that extends around at least a portion of the tubular member. The filament can interact with the tubular member to constrict, collapse, and/or seal the tubular member via manipulation of the tensioning mechanism(s). A tool can be inserted through the valve to gain access to a patient’s body and specifically to gain access to a blood vessel. Through the use of the tensioning mechanism and filament to constrict, collapse, and/or seal the tubular member, the valve can seal around a wide range of tool sizes and shapes, as well as multiple tools of differing sizes simultaneously. Additionally, such a valve creates a robust seal that maintains its seal when a vacuum is applied such as occurs during aspiration.

[0007] Aspects of the present disclosure relate to a hemostatic valve for sealing a medical device. The hemostatic valve includes an elongate member having a first end, a second end, and a central lumen extending therebetween. In some embodiments, the elongate member is pliable. The hemostatic valve can include a reinforcement structure extending along at least a portion of the elongate member, such that the reinforcement structure is coupled to the elongate member. The hemostatic valve includes an active tensioning mechanism coupled to the elongate member. In some embodiments, the tensioning mechanism is moveable between a first configuration in which the central lumen is constricted and sealed and a second configuration in which the central lumen is open. Optionally, the valve may be manually adjusted by the user to intermediate positions between fully open and fully closed. Additionally, an instrument (e.g. catheter) may provide an intermediate position where the valve creates hemostasis without user adjustment.

[0008] In some embodiments, the elongate member can be a compliant polymer tube. In some embodiments, the tensioning mechanism can include at least one filament extending at least partially around the elongate member. In some embodiments, the reinforcement structure is positioned between the at least one filament and the elongate member. In some embodiments, the reinforcement structure can be a braided mesh. In some embodiments, the reinforcement structure is coupled to the elongate member at a position proximate to the first end of the elongate member and at a position proximate to the second end of the elongate member. In some embodiments, the reinforcement structure is not coupled to the elongate member at a position between the first end of the elongate member and the second end of the elongate member. In some embodiments, the central portion of the compliant polymer tube that is constrained or collapsed by the tensioning mechanism, and at least one filament, is not coupled to the reinforcement structure.

[0009] In some embodiments, the tensioning mechanism can include an actuator coupled to the at least one filament. In some embodiments there are two tensioning mechanisms coupled to the at least one filament that operate in opposite directions. In some embodiments the two tensioning mechanisms are attached to the same filament. In some embodiments the two tensioning mechanisms are attached to opposing filaments. In some embodiments, the actuator can be moveable to control movement of the at least one filament from a first position in which the central lumen is constricted

and sealed to a second position in which the central lumen is open. In some embodiments, the at least one filament is in the first position when the tensioning mechanism is in the first configuration. In some embodiments, the actuator is biased towards the first position. In some embodiments, the actuator is biased toward the second position. In some embodiments, the actuator can be a manual actuator.

**[0010]** In some embodiments, the at least one filament forms a loop around the elongate member. In some embodiments, the at least one filament forms a bight around a portion of the elongate member. In some embodiments, the at least one filament can include a first filament and a second filament. In some embodiments, each of the first filament and the second filament are coupled to the same actuator. In some embodiments, each of the first filament and the second filament are coupled to different actuators. In some embodiments, the first filament and the second filament are moveable from the first position to the second position. In some embodiments, each of the first filament and the second filament form a loop around the elongate member. In some embodiments, the first filament forms a first bight around a first portion of the elongate member, and the second filament forms a second bight around a second portion of the elongate member. In some embodiments, the first bight extends through the second bight.

**[0011]** In some embodiments, the hemostatic valve can include a shell defining a first aperture and a second aperture. In some embodiments, the elongate member extends from the first aperture to the second aperture and fluidly couples the first aperture and the second aperture. In some embodiments, the tensioning mechanism is self-adjustable to seal around tools of different sizes extending through the hemostatic valve. In some embodiments, the central lumen can comprise a single lumen, and in some embodiments, the central lumen can comprise a plurality of lumens.

**[0012]** One aspect of the present disclosure relates to a delivery system for intravascular access of a blood vessel within a patient's body. The delivery system includes a catheter having a first end, a second end, and a catheter lumen extending therebetween and a hemostatic valve coupled to the first end of the catheter. The hemostatic valve includes a tubular member having a first end, a second end, and a central lumen extending therebetween. In some embodiments, the central lumen of the tubular member is fluidly coupled with the catheter lumen. The hemostatic valve includes an active tensioning mechanism coupled to the tubular member, the tensioning mechanism can be moveable between a first configuration in which the tensioning mechanism constricts on the central lumen and the central lumen is sealed and a second configuration in which the central lumen is open.

**[0013]** In some embodiments, the hemostatic valve further includes a reinforcement structure extending along at least a portion of the tubular member. In some embodiments, the reinforcement structure is located between the tensioning mechanism and the tubular member. In some embodiments, the reinforcement structure can be a braided mesh. In some embodiments, the reinforcement structure is coupled to the tubular member at a position proximate to the first end of the tubular member and at a position proximate to the second end of the tubular member. In some embodiments, the reinforcement structure is adhered to the tubular member at the first end of the tubular member and at the second end of the tubular member. In some embodiments, the reinforce-

ment structure is uncoupled to the tubular member between the first end of the tubular member and the second end of the tubular member.

**[0014]** In some embodiments, the tensioning mechanism can include at least one filament extending at least partially around the tubular member. In some embodiments, the tensioning mechanism can include an actuator coupled to the at least one filament. In some embodiments, moving the tensioning mechanism from the first configuration to the second configuration can include moving the actuator and the thereto coupled at least one filament from a first position to a second position. In some embodiments, the filament constricts and seals the central lumen of the tubular member when the filament is in the first position.

**[0015]** In some embodiments, the actuator can be a manual actuator. In some embodiments, the actuator can include a pair of opposing and depressable buttons, which buttons can be biased towards an undepressed position. In some embodiments, the central lumen is sealed when the buttons are in the undepressed position. In some embodiments, the filament can be a monofilament. In some embodiments, the filament can be at least one of: a polymer filament; or a metallic filament. In some embodiments, the catheter can include a thrombus extraction device.

**[0016]** One aspect of the present disclosure relates to a method of sealing a delivery device accessing a blood vessel of a patient. The method includes inserting the delivery device including a catheter and a hemostatic valve into the blood vessel of the patient. In some embodiments, the catheter can have a first end, a second end, and a catheter lumen extending therethrough. In some embodiments, the hemostatic valve can be coupled to the first end and can have a tubular member defining a central lumen fluidly coupled with the catheter lumen and a tensioning mechanism coupled with the tubular member. In some embodiments, the tensioning mechanism collapses and seals the central lumen in a first configuration and thereby seals access to the blood vessel. The method can include moving the tensioning mechanism of the hemostatic valve to a second configuration. In some embodiments, the central lumen is open and access to the blood vessel is unsealed when the tensioning mechanism is in the second configuration. The method can include advancing a shaft of a tool through the delivery device until a first end of the tool reaches a desired position within the blood vessel of the patient and a portion of the shaft is positioned within the central lumen of the tubular member. The method can include returning the tensioning mechanism of the hemostatic valve to the first configuration such that the tubular member collapses on the shaft of the tool and seals around the shaft of the tool.

**[0017]** In some embodiments, the method includes retracting the shaft of the tool from the delivery device. In some embodiments, the tensioning mechanism is maintained in the first configuration during and after the retracting of the shaft of the tool from the delivery device. In some embodiments, the tensioning mechanism is moved to the second configuration during the retracting of the shaft of the tool from the delivery device, and the tensioning mechanism is returned to the first configuration after the shaft of the tool is retracted from the delivery device.

**[0018]** In some embodiments, the tensioning mechanism can include at least one filament extending at least partially around the tubular member. In some embodiments, the at least one filament collapses the tubular member when the

tensioning mechanism is in the first configuration. In some embodiments, the at least one filament circumferentially constricts the tubular member to collapse the tubular member when the tensioning mechanism is in the first configuration. In some embodiments, the hemostatic valve can include a reinforcement structure located between the at least one filament and the tubular member.

**[0019]** In some embodiments, the at least one filament forms a loop around the elongate member, and moving the tensioning mechanism from the second configuration to the first configuration reduces a size of the loop to thereby constrict the tubular member within the loop. In some embodiments, the filament forms at least one bight around a portion of the elongate member. In some embodiments, the filament can include a first filament and a second filament. In some embodiments, the at least one bight can include a first bight oriented in a first direction and formed by the first filament and a second bight oriented in a second direction and formed by the second filament. In some embodiments, the first and second bights overlap to encircle a portion of the tubular member within a constricting area.

**[0020]** In some embodiments, moving the tensioning mechanism from the second configuration to the first configuration can include moving the first bight in the first direction and the second bight in the direction to reduce the size of the constricting area and collapse and seal the central lumen of the tubular member. In some embodiments, the tensioning mechanism can include an actuator. In some embodiments, moving the tensioning mechanism to the second configuration can include manipulating the actuator. In some embodiments, the method includes applying a vacuum to the delivery device and/or delivery system to aspirate material through the catheter. In some embodiments, the central lumen remains sealed during the aspiration. In some embodiments, the tool can include a thrombus extraction device.

#### BRIEF DESCRIPTION OF THE DRAWINGS

**[0021]** FIG. 1 is a perspective view of one embodiment of a delivery device.

**[0022]** FIG. 2 is a side-section view of one embodiment of a hemostasis valve in a first configuration.

**[0023]** FIG. 3 is a side-section view of one embodiment of the valve in a second configuration.

**[0024]** FIG. 4 is a side-section view of one embodiment of the valve in the first configuration and with a tool extending through the valve.

**[0025]** FIG. 5 is a side-section view of one embodiment of a single-button hemostasis valve in a first configuration.

**[0026]** FIG. 6 is a perspective view of a filament of a valve forming a loop.

**[0027]** FIG. 7 is a perspective view of two filaments of a valve, each of the filaments forming a loop.

**[0028]** FIG. 8 is a perspective view of two overlapping and interlocked bights in an open configuration.

**[0029]** FIG. 9 is a perspective view of two overlapping and interlocked bights in a closed configuration.

**[0030]** FIG. 10 is a flowchart illustrating one embodiment of a method for sealing a valve and/or catheter.

**[0031]** FIG. 11 is a side view of one embodiment of a thrombectomy system including the delivery device.

**[0032]** FIG. 12 is a side-section view of another embodiment of a hemostasis valve having two-piece caps.

#### DETAILED DESCRIPTION

**[0033]** The present disclosure relates to a valve that can be used a hemostasis valve. This valve, also referred to herein as a garrote valve can seal with or without a tool extending through the valve. The garrote valve provides convenient, single-handed operation for a wide range of medical devices including catheters, wires, embolectomy systems, or the like. This single-handed operation of the garrote valve allows the user to easily and quickly swap different tools being used through the valve without compromising hemostasis and therefore simplifying the procedure. Combined with single-handed operation, the garrote valve provides robust sealing either with or without a tool extending through the valve. This robust sealing minimizes leakage in applications with a pressure differential on different sides of the valve. This pressure differential can arise, for example, during the application of vacuum aspiration in a procedure. Even under such conditions, as well as under other conditions, the garrote valve maintains seal integrity and prevents leakage in one or both directions.

**[0034]** The garrote valve includes a tubular member. The tubular member is a flexible member that defines a central lumen, which can, in some embodiments, define a single lumen, and in some embodiments, defines a plurality of lumens. In some embodiments, each of the plurality of lumens can comprise the same size and shape, and in some embodiments, some or all of the plurality of lumens can comprise different sizes and shapes. In some embodiments, for example, the plurality of lumens can comprise a lumen sized and/or shaped to receive a guide wire and a lumen sized and/or shaped to receive a tool. The tubular member extends at least partially through a constricting mechanism. The constricting mechanism can be moved from a first configuration to a second configuration, and the constricting mechanism can collapse and/or seal the central lumen of the tubular member when the constricting mechanism is in the first configuration. The constricting mechanism creates the above-discussed robust seal of the tubular member and thus of the valve.

**[0035]** With reference now to FIG. 1, a perspective view of one embodiment of a delivery system 100, also referred to herein as a delivery device 100, is shown. The delivery system 100 can include a catheter 102 and a garrote valve 104, also referred to herein as valve 104. The catheter 102 can comprise a shaft 106, also referred to herein as an elongate sheath 106, having a proximal end 108, also referred to herein as a first end 108, that can connect to the valve 104 and a distal end 110, also referred to herein as a second end 110. The shaft 106 can define a catheter lumen 112 extending from the proximal end 108 of the shaft 106 to the distal end 110 of the shaft 106. The catheter 102 and specifically the shaft 106 can comprise a variety of shapes and sizes and can be made from a variety of materials. In some embodiments, the catheter 102 can be flexible and/or can be made from a biocompatible material. The elongate sheath 106 can have an outer diameter of at least 4 French, at least 6 French, at least 8 French, at least 10 French, at least 12 French, at least 14 French, at least 18 French, at least 20 French, at least 22 French, between 4 French and 30 French, between 8 French and 24 French, between 12 French and 20 French, and/or any other or intermediate size.

**[0036]** The valve 104 can include an outer shell 114. The outer shell 114 can comprise a variety of shapes and sizes and can be made from a variety of materials. In some

embodiments, the outer shell **114** can be made from one or several polymers or composites. The outer shell **114** can include features that allow interaction with and/or control of the valve **104** to move the valve **104** between the first configuration and the second configuration.

[0037] The outer shell **114** can include a proximal cap **116** located at a proximal end **118** of the outer shell **114** and a distal cap **120** located at a distal end **122** of the shell **114**. The proximal cap **116** can include and/or house a proximal aperture **124**, also referred to herein as a proximal channel **124**, a first channel **124**, or a first aperture **124**, that extends through the proximal cap **116**, and the distal cap **120** can include and/or house a distal aperture **126**, also referred to herein as a distal channel **126**, a second channel **126**, or second aperture **126**, that extends through the distal cap **120**. As seen in FIG. 1, the distal cap **120** connects to the shaft **106** of the catheter **102** at the distal end **122** of the valve **104**.

[0038] The proximal cap **116** and the distal cap **120** are connected via a housing **128**. The housing **128** can be a one-piece housing **128** or a multi-piece housing **128**. In the embodiment depicted in FIG. 1, the housing comprises a two-piece housing **128**. The housing **128** can be configured to receive and couple with each of the proximal cap **116** and the distal cap **120**, and as seen in FIG. 1, the housing **128** is coupled with each of the proximal cap **116** and the distal cap **120** to secure the relative position of the proximal cap **116** and the distal cap **120** with respect to each other.

[0039] The housing **128** can define an interior channel **130** through which an elongate member **132**, also referred to herein as a tubular member **132**, a septum **132**, or a tubular septum **132**, can extend and connect the proximal cap **116** and the distal cap **120**. The elongate member **132** can comprise a variety of shapes and sizes and can be made from a variety of materials. In some embodiments, the elongate member **132** can comprise a compliant tubular structure that can be, for example, a thin-walled compliant tubular structure. The thin-walled structure of the elongate member **132** can facilitate the collapse, and specifically the uniform collapse of the elongate member **132** and the scaling of the elongate member **132**. In some embodiments, the elongate member **132** is an elastic, resilient material that may comprise a polymer including either a natural or synthetic polymer. In some embodiments, the elongate member can comprise an elastic, resilient material that may comprise silicone, urethane, ethylene-vinyl acetate, natural or synthetic rubber or other elastomers known in the art. In some embodiments, the elongate member **132** can comprise a silicone tube.

[0040] The elongate member **132** can comprise a proximal end **134**, also referred to herein as a first end **134**, that can couple to the proximal cap **116**, and a distal end **136**, also referred to herein as a second end **136**, that can couple to the distal cap **120**. The elongate member **132** can define a central lumen **138** that can extend from the first end **134** to the second end **136** of the elongate member **132**. The elongate member **132** can be coupled to the proximal cap **116** such that the central lumen **138** is fluidly coupled with the proximal aperture **124** of the proximal cap **116**, and the elongate member **132** can be coupled to the distal cap **120** such that the central lumen **138**, as seen in FIG. 2 and in FIG. 3, is fluidly coupled with the distal aperture **126** of the distal cap **120**.

[0041] The central lumen **138** of the elongate member **132** can be defined by a wall of the elongate member **132** that can

have a thickness that is uniform along the length of the elongate member **132** between the first end **134** and the second end **136**, or that is non-uniform along the length of the elongate member **132** between the first end **134** and the second end **136**. In some embodiments, the wall can have a thickness that is approximately between 0.005 inches and 0.05 inches, and/or approximately between 0.010 inches and 0.030 inches. As used anywhere herein, “approximately” refers to a range of  $\pm 10\%$  of the value and/or range of values for which “approximately” is used.

[0042] In some embodiments, the elongate member **132** can be cylindrically shaped, and specifically can be circular-cylindrically shaped. In some embodiments, the elongate member **132** can be dog-bone shaped to facilitate, for example, connection to each of the proximal cap **116** and the distal cap **120**. In some embodiments, the elongate member **132** can include one or several outward-extending protuberances that engage with all or portions of a constricting mechanism **141**, also referred to herein as a tensioning mechanism **141**, of the valve **104** to secure a position of all or portions of the constricting mechanism **141** with respect to the elongate member **132**. In some embodiments, the constricting mechanism **141** can be self-adjusting to seal around tools of different sizes extending through the valve **104**.

[0043] The constricting mechanism **141** can, in some embodiments, collapse and seal the elongate member **132** via compression and/or constriction, and specifically via constriction with at least one filament **150**. The constricting mechanism **141** can comprise: an actuator **142** which can be a manual actuator such as one or several buttons **144**; and the at least one filament **150** that can extend at least partially around the elongate member **132**. In some embodiments, the use of the constricting mechanism **141** can facilitate sealing of the valve around tools or instruments of a wide range of sizes and/or diameters, and particularly around tools or instruments that fit through the elongate member **132**.

[0044] The housing **128** can further include one or several retention features **140**. The one or several retention features **140** of the housing can engage with and retain all or portions of the constricting mechanism **141** of the valve **104**. In some embodiments, the one or several retention features **140** of the housing **128** can retain the actuator **142** and/or can couple the actuator **142** to the housing **128**. The actuator **142** can comprise any desired type of actuator including, for example, a manual actuator and/or an automated actuator such as, for example, an electromechanical actuator including a solenoid-based actuator. In some embodiments, the actuator can comprise one or several buttons **144**, and specifically, as depicted in FIG. 1, the actuator **142** can comprise a first button **144-A** and a second button **144-B**. Alternatively, and as depicted in FIG. 5, the actuator **142** can comprise a single button **144**. In such an embodiment, the filament **150** can be coupled to the single button **144** and to a portion of the housing **128** such as, for example, to grip portion **500** of the housing **128** such that the movement of the single button **144** causes the sealing and/or opening of the elongate member **132** and of the valve **104**.

[0045] The actuator **142** can be biased towards a configuration such as, for example, biased towards the first configuration or biased towards the second configuration. As depicted in FIG. 2, which shows the constricting mechanism **141** in the first configuration, the actuator **142** can be biased towards the first configuration wherein the elongate member

**132** is collapsed and/or sealed by a bias feature **146**. In this first configuration, the buttons **144** can be in a first position, also referred to herein as an undepressed position. This bias feature **146** can, as shown in FIG. 2, include a first spring **148-A** configured to bias the first button **144-A** towards the first position corresponding to the first configuration of the constricting mechanism **141**, and a second spring **148-B** configured to bias the second button **144-B** towards a first position corresponding to the first configuration of the constricting mechanism **141**. One or both of the first spring **148-A** and the second spring **148-B** can comprise a tension spring, compression spring, a torsion spring, a coil spring, or any other desired type of spring.

[0046] In some embodiments, one or both of the first spring **148-A** and the second spring **148-B** can generate sufficient force so as to allow actuation of the actuator **142** with a single hand and so as to collapse and seal the elongate member **132** when the constricting mechanism **141** is in the first configuration. In some embodiments, one or both of the first spring **148-A** and the second spring **148-B** can generate a force of: at least 0.1 pounds, at least 0.2 pounds, at least 0.3 pounds, at least 0.4 pounds, at least 0.5 pounds, at least 0.6 pounds, at least 0.7 pounds, at least 0.8 pounds, at least 0.9 pounds, at least 1 pound, at least 1.5 pounds, at least 2 pounds, at least 3 pounds, at least 5 pounds, and/or at least 10 pounds and in some embodiments one or both of the first spring **148-A** and the second spring **148-B** can generate a force approximately between: 0.1 and 10 pounds, 0.1 and 5 pounds, 0.1 and 1.5 pounds, 0.2 and 1 pounds, and/or 0.4 and 0.8 pounds.

[0047] The constricting mechanism **141** can include at least one filament **150** that extends at least partially around the elongate member **132**. In some embodiments, the at least one filament **150** can circumferentially constrict the elongate member **132** to collapse and seal the elongate member **132** when the constricting mechanism **141** is in the first configuration. The filament can be made from a variety of materials including, for example, a polymer, a synthetic, and/or a metal. In some embodiments, the filament **150** can be nylon, stainless steel, nitinol, silicone, or the like. In some embodiments, the filament can comprise a single strand such as, for example, a monofilament, and in some embodiments, the filament can comprise a plurality of strands that can be, for example, twisted, woven, grouped, and/or fused to form the filament. In some embodiments, the filament **150** can comprise one or several threads, lines, cords, rope, ribbon, flat wire, sheet, or tape.

[0048] The filament **150** can be coupled to the actuator **142** such that the filament **150** selectively constricts, collapses, and/or seals the elongate member **132**, and specifically the central lumen **138** of the elongate member **132** based on the movement and/or position of the actuator **142**. In some embodiments, the filament **150** can be connected to one or both of the buttons **144-A**, **144-B** such that the filament **150** collapses, constricts, and/or seals the elongate member **132** and specifically the central lumen **138** of the elongate member **132** when the buttons **144-A**, **144-B** are in the first position, and the filament **150** can be connected to one or both of the buttons **144-A**, **144-B** such that the elongate member **132** and specifically the central lumen **138** of the elongate member **132** is open and uncollapsed when the buttons **144-A**, **144-B** are in the second position. In some embodiments in which the actuator **142** comprises a single button **144**, as depicted in FIG. 5, the filament **150** can be

connected to the button **144** and to the housing **128** such that the filament **150** is tightened when the button **144** moves to the first position.

[0049] In some embodiments, the at least one filament **150** can extend along an axis **152** that can be perpendicular to a central axis **154** of the elongate member **132** and/or of the apertures **124**, **126**. In some embodiments, the axis **152** of the at least one filament **150** can intersect and be perpendicular to the central axis **154** of the elongate member **132** and/or of the apertures **124**, **126**. In some embodiments, the actuator **142**, and specifically the buttons **144-A**, **144-B** can move along this axis **152** when moved from the first position to the second position.

[0050] In FIG. 3, an embodiment of the valve **104** with the constricting mechanism **141** in the second configuration is shown. As specifically shown, both of the first and second buttons **144-A**, **144-B** are in the second position, depressed into the retention features **140** of the housing **128**. In this second position, the filament **150** is loosened, thereby allowing the expansion of the elongate member **132** and the unscaling of the central lumen **138** of the elongate member **132**.

[0051] As further seen in FIG. 3, the proximal cap **116** has a proximal end **300** and a distal end **302**. The proximal cap **116** can include a funnel portion **301** of the proximal aperture **124**, which funnel portion **301** can facilitate insertion of a tool into the proximal aperture **124**. The distal end **302** of the proximal cap **116** can partially extend into the interior channel **130** of the housing **128**. The proximal cap **116** can include a mating feature **304** that can mate with the proximal end **134** of the elongate member **132**. In some embodiments, the proximal end **134** of the elongate member **132** can fit over the mating feature **304** of the proximal cap **116**. The proximal end **134** of the elongate member **132** can be compressed between the mating feature **304** of the elongate member **132** and a portion of the interior channel **130** of the housing **128** into which the mating feature **304** is inserted to thereby secure the proximal end **134** of the elongate member **132** on the mating feature **304**. In some embodiments, the proximal end **134** of the elongate member **132** can be further secured on the mating feature **304** by a proximal O-ring **306** that can be compressed between the housing **128** and the mating feature **304** of the proximal cap **116** to sealingly couple the elongate member **132** to the proximal cap **116**.

[0052] The distal cap **120** has a proximal end **308** and a distal end **310**. The distal cap can include a mating feature **312** located on the proximal end **308** of the distal cap **120**, which mating feature **312** can mate with the distal end **136** of the elongate member **132**. In some embodiments, the distal end **136** of the elongate member **132** can fit over the mating feature **312** of the distal cap **123**. The distal end **136** of the elongate member **132** can be compressed between the mating feature **312** of the elongate member **132** and a portion of the interior channel **130** of the housing **128** into which the mating feature **312** is inserted to thereby secure the distal end **136** of the elongate member **132** on the mating feature **312**. In some embodiments, the distal end **136** of the elongate member **132** can be further secured on the mating feature **312** by a distal O-ring **314** that can be compressed between the housing **128** and the mating feature **312** of the proximal cap **116** to sealingly couple the elongate member **132** to the distal cap **120**.



[0053] The distal cap 120 can, in some embodiments, further include a side port barb 314 that can extend laterally away from the distal cap 120 and specifically away from the distal aperture 126 of the distal cap 120. The side port barb 314 can define a side port channel 316 that can extend through the side port barb 314 and fluidly connect to the distal aperture 126. In some embodiments, the side port barb 314 can include a securement feature 318 such as a barb that can secure coupling of a hose or tube to the side port barb 314.

[0054] In some embodiments, the side barb 314 can be used to apply a vacuum to the portions of the delivery device 100, and particularly to portions of the delivery device 100 that are distal of the axis 152 along which the elongate member 132 seals. This vacuum can be applied to aspirate a material through the delivery device 100, and specifically through the catheter 102 of the delivery device. This aspirated material can be a biological material including, for example, bodily fluids, multi-phase bodily materials that can include, for example, a fluidic portion and at least one solid portion, or the like.

[0055] In some embodiments, due to the narrowing shape of the elongate member 132 when the constricting mechanism 141 is in the first configuration, a vacuum applied to the portions of the delivery device 100 distal to the axis 152 draws the elongate member 132 towards the first configuration and can, in some embodiments, increase the strength, robustness, and/or strength of the seal of the valve 104. This attribute of the valve 104 can provide benefits over other valve designs in which a vacuum can compromise the seal of the valve, and thus the ability to draw a vacuum and aspirate can be limited.

[0056] In some embodiments, the valve 104 can further include a reinforcement structure 320 that can extend along all or portions of the elongate member 132. The reinforcement structure 320 can facilitate the uniform collapse of the elongate member 132, can prevent the at least one filament 150 from cutting through and/or tearing the elongate member 132, and can assist in guiding one or several tools through the elongate member 132. The reinforcement structure 320 can be tubular, can extend along and around the elongate member 132, and can be positioned so as to be between the elongate member 132 and the at least one filament 150.

[0057] The reinforcement structure 320 can include a proximal end 322 and a distal end 324. In some embodiments, the reinforcement structure 320 extends along and around the elongate member 132, and is positioned such that the proximal end 322 of the reinforcement structure 320 is proximate to the first end 134 of the elongate member 132 and the distal end 324 of the reinforcement structure 320 is proximate to the second end 136 of the elongate member 132.

[0058] The reinforcement structure 320 can be coupled to the elongate member 132. In some embodiments, the reinforcement structure 320 is coupled to the elongate member 132 along the length of the reinforcement structure 320, and in some embodiments, the reinforcement structure 320 is coupled to the elongate member 132 and distinct positions along the length of the elongate member 132 and/or the reinforcement structure 320. In one embodiment, for example, the reinforcement structure 320 can be coupled to the elongate member 132 at one or both of the proximal end 322 of the reinforcement structure 320 and the distal end 324

of the reinforcement structure 320 and/or at one or both of the first end 134 and the second end 136 of the elongate member 132. In some embodiments, the reinforcement structure 320 can be coupled to the elongate member 132 via one or several other components of the valve 104. In some embodiments, the reinforcement structure 320 can be coupled to the elongate member 132 via the compression of the reinforcement structure 320 and the elongate member 132 between the housing 128 and one or both of the proximal 116 and the distal 120.

[0059] In some embodiments, the reinforcement structure 320 can be adhered to the elongate member 132 via, for example, an adhesive such as silicone adhesive. In some embodiments, the adhesive can be circumferentially applied to the reinforcement structure 320 and/or the elongate member 132 in an adhesive ring that can, for example, have a length approximately between: 0.010 inches and 0.5 inches; 0.02 and 0.4 inches; 0.050 inches and 0.0250 inches, or any other or intermediate range.

[0060] In one embodiment, each of the proximal end 322 and the distal end 324 of the reinforcement structure 320 can be adhered via an adhesive to the elongate member 132. In such an embodiment, the reinforcement structure 320 may be uncoupled to the elongate member 132 at positions other than the coupling at one or both of the proximal end 322 and the distal end 324 of the reinforcement structure 320, and thus the reinforcement structure 320 is uncoupled to the elongate member 132 at a position between the first end 134 and the second end 136 of the elongate member 134 and/or between the proximal end 322 and the distal end 324 of the reinforcement structure 320.

[0061] The lack of coupling of the reinforcement structure 320 to the elongate member 132 can facilitate and improve the collapse of the elongate member 132 around a tool 400, also referred to herein as instrument 400 or device 400, inserted through the valve 104 as shown in FIG. 4. The tool 400 can be any device inserted through the valve 104 including, for example, one or several additional catheters, lines, wires, grippers, punches, cutters, or the like. As seen in FIG. 4, the tool 400 is inserted through the valve 104 and specifically through the elongate member 132 of the valve. As shown, the constricting mechanism 141 is in the first configuration and the elongate member 132 and the central lumen 138 of the elongate member 132 is collapsed around the tool 400, and specifically around a shaft 402 of the tool 400 to thereby seal the valve 104 around the tool 400 and specifically around the shaft 402 of the tool 400. The constricting mechanism 141 can seal around tools 400 that fit through the elongate member 132, regardless of the size of the tool 400. Thus, the valve can be used with a wide variety of tools.

[0062] The reinforcement structure 320 can comprise a variety of designs, shapes, sizes, and materials. In some embodiments, the reinforcement structure 320 can be sized and shaped so as to receive elongate member 132 and to be positioned between the elongate member 132 and the at least one filament 150. In some embodiments, the reinforcement structure 320 can be made from a material sufficiently strong to prevent the cutting of the at least one filament 150 through the elongate member 132.

[0063] In some embodiments, the reinforcement structure can comprise a coil or a mesh sheath. The mesh sheath can, in some embodiments, comprise a braided mesh. The braided mesh can be made from any desired number of wires

in any desired configuration. In some embodiments, the braided mesh can comprise a 4 wire braided mesh, an 8 wire braided mesh, a 12 wire braided mesh, a 16 wire braided mesh, a 20 wire braided mesh, a 24 wire braided mesh, a 32 wire braided mesh, a 48 wire braided mesh, a 64 wire braided mesh, a 72 wire braided mesh, an 80 wire braided mesh, a 96 wire braided mesh, or any other or intermediate braided mesh. In some embodiments, the braided mesh can comprise: a 1×1 configuration. In some embodiments, the wire in the braided mesh can be any desired material including, for example, a metal wire such as a nitinol wire or a stainless steel wire, a polymer wire, or a natural wire. In one embodiment, the braided mesh can comprise a 48 wire mesh in a 1×1 configuration made with a nitinol wire having a diameter of 0.003 inches.

[0064] With reference now to FIGS. 6 through 9, different embodiments and/or configurations of the filament 150 are shown. The filament 150 can comprise a single filament 150 having a first end 600 and a second end 602 as shown in FIG. 6. The filament 150, and specifically which first and second ends 600, 602 can be coupled to the actuator 142 to move the filament 150 between the first and second configurations or positions and/or from the first configuration or position to the second configuration or position. In some embodiments, both of the first end 600 and the second end 602 can be coupled to a single button 144, in some embodiments, each of the first end 600 and the second end 602 can be coupled to different buttons 144, and in some embodiments, one of the first end 600 and the second end 602 can be coupled to a button 144 and the other of the first end 600 and the second end 602 can be coupled to the housing 128 or other portion of the valve 104.

[0065] In some embodiments, the filament 150 can comprise multiple filaments, and specifically, as shown in FIGS. 7 through 9, the filament 150 can comprise a first filament 150-A and a second filament 150-B. In embodiments in which the filament 150 comprises multiple filaments, each of the multiple filaments can have a first end 700 and a second end 702. The first and second filaments 150-A, 150-B can be coupled to the actuator 142. In such embodiments, the first and second ends 700, 702 can be coupled to the actuator 142 to move the filaments 150-A, 150-B between the first and second configurations and/or from the first configuration to the second configuration. In some embodiments, both of the first end 700 and the second end 702 of one or more of the multiple filaments 150 can be coupled to a single button 144, in some embodiments, each of the first end 700 and the second end 702 of one or more of the multiple filaments 150 can be coupled to different buttons 144, and in some embodiments, one of the first end 700 and the second end 702 of one or more of the multiple filaments 150 can be coupled to one button 144 and the other of the first end 700 and the second end 702 of those one or more filaments 150 can be coupled to the housing 128 or other portion of the valve 104.

[0066] The filament 150 can be arranged in a variety of configurations. In some embodiments, the filament 150 can be configured to form a single loop 604 that can extend around the elongate member 132 and/or through which the elongate member 132 can be received as shown in FIG. 6, and in some embodiments, the filament 150 can be configured to form multiple loops, and specifically a first loop 704 and a second loop 706 as shown in FIG. 7. The first and second loops 704, 706 can each receive the elongate member

132. In some embodiments, a diameter or size of the loop 604, or of the loops 704, 706 can decrease when the constricting mechanism 141 is moved from the second configuration to the first configuration.

[0067] In some embodiments, the filament 150 can be configured to form a bight 800, which bight 800 can be a single bight or multiple bights. As used herein, a “bight” refers to a U-shaped section between the two ends of the filament 150. As depicted in FIGS. 8 and 9, the bight 800 can comprise multiple bights, and specifically a first bight 800-A and a second bight 800-B. In some embodiments, the first bight 800-A can extend through the second bight 800-B such that the first and second bights 800-A, 800-B interlock, whereas in other embodiments, the first and second bights 800-A, 800-B can be non-interlocking. Similarly, in embodiments containing the filament 150 having multiple loops, one or several of the multiple loops can be interlocking.

[0068] In some embodiments, the bight 800, and specifically one or both of the first bight 800-A and the second bight 800-B can be formed around a portion of the elongate member 132 and/or can extend around a portion of the elongate member 132. Each bight 800 can define a partially enclosed receiving area 808 wherein the elongate member 132 can be received. Thus, the first bight 800-A can define a first receiving area 808-A and the second bight 800-B can define a second receiving area 808-B.

[0069] As seen in FIGS. 8 and 9, multiple bights, and specifically the first and the second bights 800-A, 800-B can be positioned and oriented such that the first bight 800-A has a first orientation or first direction as indicated by arrow 810, and the second bight has a second orientation or second direction as indicated by the arrow 812. In some embodiments, the first orientation is different from the second orientation such that the first and second receiving areas 808-A, 808-B overlap and define an encircled area 814, also referred to herein as a constricting area 814. The elongate member 132 can be received within the encircled area 814. In embodiments in which bights 800-A, 800-B overlap to define the encircled area 814, the movement of the constricting mechanism 141 to the first configuration can result in and/or include the first bight 800-A moving in the direction indicated by the arrow 810 and/or the second bight 800-B moving in the direction indicated by the arrow 812, which movement of the bights 800-A, 800-B decreases the size of the encircled area 814 and constricts, collapses, and/or seals the elongate member 132 extending through the encircled area 814.

[0070] The filament(s) 150 forming the bights 800 can each apply an arcuate line or narrow longitudinal zone of pressure to the elongate member 132. If the filament(s) are circular in cross-section, the zone of pressure can be very small, and can, in some embodiments, be less than the diameter or thickness of the filament. In some embodiments, the filaments have a diameter or width less than about 2.5 mm, less than about 2 mm, less than about 1.5 mm, less than about 1.25 mm, less than about 1 mm, less than about 0.75 mm, less than about 0.5 mm, and/or less than about 0.25 mm. In some embodiments, the filaments can have a diameter or width of between about 0.01 mm and 2.5 mm, between about 0.05 mm and 2 mm, between about 0.1 mm and 1 mm, and/or between about 0.125 mm and 0.7 mm. In some embodiments, the arcuate line or zone of pressure may form two opposing arcs and in other embodiments, the arcuate line of pressure may be a singular substantially

circular line or zone that encircles the elongate member at least once. The longitudinal length of the of the line or zone of pressure may be very short compared to other valves known in the art. In some embodiments, the longitudinal length of the zone of pressure applied to the elongate member 132 by the filament(s) 150 may be less than about 2.0 mm and in some embodiments less than about 0.5 mm. In some embodiments, the filament(s) 150 can have any desired cross-sectional shape including, for example, a circular cross-section, a rectangular cross-section, an oval cross-section, a square cross-section, a polygonal cross-section, a triangular cross-section, or any other desired shape of cross-section.

[0071] With reference now to FIG. 10, a flowchart illustrating one embodiment of a process 1000 for sealing a valve 104 and/or catheter 102 accessing a body of a patient is shown. The process 1000 can be performed using the valve 104 and/or the delivery system 100. The process 1000 begins at block 1002, wherein the delivery device 100, and specifically the catheter 102 of the delivery device 100 is inserted into the body of the patient. In some embodiments, this can include inserting the catheter 102 into a portion of the circulator system of the patient such as, for example, a blood vessel including an artery or a venous vessel. In some embodiments, the delivery device 100 can be inserted into the body of the patient directly through an aperture or incision in the patient, and in some embodiments, the delivery device 100 can be inserted into the body of the patient via another catheter or device. In some embodiments, the constricting mechanism 141 can be in the first configuration while the delivery device 100 and/or the catheter 102 is inserted into the patient's body.

[0072] After the delivery device 100 is inserted into the body of the patient, the process 1000 proceeds to block 1004, wherein the constricting mechanism 141 is moved from the first configuration to the second configuration. As described above, the central lumen 138 of the elongate member 132 is unsealed when the constricting mechanism 141 is in the second configuration. In some embodiments, the moving of the constricting mechanism 141 from the first configuration to the second configuration can include the manipulation of the actuator 142 and/or the control of the actuator 142, and specifically the depressing of the one or several buttons 144 to move the filament 150 from the first position to the second position to allow the expansion and opening of the central lumen 138 of the elongate member 132.

[0073] After the constricting mechanism 141 is moved from the first configuration to the second configuration, the process 1000 proceeds to block 1006, wherein the tool 400, and specifically the shaft 402 of the tool 400 is advanced through the delivery device 100 and specifically through the valve 104 until a first end of the tool reaches a desired position within the body of the patient. In some embodiments, a portion of the shaft 402 can be positioned within the central lumen 138 of the elongate member 132 after the advancing of the tool 400 through the delivery device 100. In some embodiments, after the tool 400 is advanced through the delivery device 100, the desired procedure can be performed with the tool.

[0074] After the tool 400 is advanced through the delivery device 100, or while the tool 400 is being advanced through the delivery device 100, the process 1000 proceeds to block 1008, wherein the constricting mechanism 141 is returned to

the first configuration. In some embodiments, the returning of the constricting mechanism 141 to the first configuration can include the release of the one or several buttons 144 and/or the control of the actuator 142 to reconfigure the constricting mechanism 141 to the first configuration. In some embodiments, the return of the constricting mechanism 141 to the first configuration can result in the collapse and/or sealing of the elongate member 132 and specifically the central lumen 138 of the elongate member 132 around the tool 400 and specifically around the shaft 402 of the tool 400. The return of the constricting mechanism 141 to the first configuration, or the movement of the constricting mechanism 141 to the first configuration can include the decreasing of the size and/or diameter of one or several loops formed by the filament 150 and/or the movement of one or several bights 800 such as, for example, the movement of the first bight 800-A in the first direction indicated by arrow 810 and the movement of the second bight 800-B in the second direction indicated by arrow 812 to reduce the size of the constricting area 814. In some embodiments, after the constricting mechanism is returned to the first configuration, the desired procedure can be performed with the tool.

[0075] After the constricting mechanism is returned to the first configuration, the process 1000 proceeds to block 1010, wherein the tool 400, and specifically the shaft 402 of the tool 400 is retracted from the delivery device 100, and more specifically from the valve 104. In some embodiments, the valve 104 can remain sealed during the retracting of the tool 400 and/or the shaft 402 of the tool. In some embodiments, the valve 104 remains sealed during the retracting of the tool 400 and/or the retracting of the shaft 402 of the tool 400 as the constricting mechanism 141 can remain in the first configuration during the retracting of the tool 400 and/or the shaft 402 of the tool 400.

[0076] In some embodiments, the constricting mechanism 141 can be moved to the second configuration to allow the retraction of the tool 400 and/or the shaft 402 of the tool 400 from the valve 104, and the constricting mechanism 141 can be returned to the first configuration when the tool 400 and/or the shaft 402 of the tool 400 is removed from the valve 104. In some embodiments, the retraction of the tool 400 and/or shaft 402 of the tool 400 from the valve 104 can be performed with the constricting mechanism 141 left in the first configuration. In some embodiments, the constricting mechanism 141 can be moved to the second configuration, and then returned to the first configuration via the manipulation and/or control of the actuator 142, which manipulation and/or control of the actuator 142 can include the depressing of the one or several buttons 144 to move the constricting mechanism 141 to the second configuration, and the release of the one or several buttons 144 to return the constricting mechanism 141 to the first configuration. In some embodiments, if the procedure is complete, the delivery device 100 can then be removed from the body of the patient, and any incision created for the procedure can be closed.

[0077] With reference now to FIG. 11, a side view of one embodiment of a thrombectomy system 1100 including the delivery device 100 and a thrombus extraction device 1102 is shown. In some embodiments, the thrombectomy system 1100 can be used to access a blood vessel 1104 to treat and/or extract a thrombus 1106 from the blood vessel 1104. The thrombus extraction device 1102 can include a self-expanding coring element 206 and expandable cylindrical

portion 208. In some embodiments, and as shown in FIG. 11, the thrombus extraction device 1102 can be the tool 400 that can extend through the valve 104, and in some embodiments, the valve 104 can be a part of the thrombus extraction device 1102. Further details of thrombectomy systems, thrombus extraction devices, and methods of using the same are disclosed in: U.S. application Ser. No. 15/268,296, filed Sep. 16, 2016, and entitled "INTRAVASCULAR TREATMENT OF VASCULAR OCCLUSION AND ASSOCIATED DEVICES, SYSTEMS, AND METHODS"; U.S. application Ser. No. 15/498,320, filed Apr. 26, 2017, and entitled "DEVICES AND METHODS FOR TREATING VASCULAR OCCLUSION"; and U.S. application Ser. No. 15/466,740, filed on Mar. 22, 2017, and entitled "DEVICE AND METHOD FOR TREATING VASCULAR OCCLUSION", the entirety of each of which is hereby incorporated by reference herein.

[0078] With reference now to FIG. 12, a side-section view of another embodiment of the hemostasis valve 104 having two piece caps 116, 120 is shown. The valve 104 can include a housing 128 defining an interior channel 130 through which the tubular member 132 can extend. The valve 104 can include the proximal cap 116 and the distal cap 120. In some embodiments, the proximal cap 116 can comprise a two piece cap and can include a proximal exterior member 1200 and a proximal channel member 1202. In some embodiments, the distal cap 120 can comprise a two-piece cap and can include a distal exterior member 1204 and a distal channel member 1206. In some embodiments, this coupling between the proximal exterior member 1200 and the proximal channel member 1202 and/or the coupling between the distal exterior member 1204 and the distal channel member 1206 can be a sealed coupling so as to prevent the leakage of material including fluid or gas between the respective ones of the proximal exterior member 1200 and the proximal channel member 1202 and/or the distal exterior member 1204 and the distal channel member 1206. In some embodiments, this sealing coupling can be achieved and/or maintained via a seal such as an O-ring 1208 that can be positioned between the proximal exterior member 1200 and the proximal channel member 1202 and/or between the distal exterior member 1204 and the distal channel member 1206.

[0079] In some embodiments, the proximal exterior member 1200 can be coupled, and in some embodiments, rotatably coupled to the proximal channel member 1202 in a manner to allow the rotation of the proximal exterior member 1200 without rotating the proximal channel member 1202. Similarly, in some embodiments, the distal exterior member 1204 can be rotatably coupled to the distal channel member 1206 in a manner to allow the rotation of the distal exterior member 1204 without the rotating of the distal channel member 1206. In some such embodiments, the channel members 1202, 1206 can be non-rotatable with respect to the housing 128 and/or the tubular member 132, and one or both of the exterior members 1200, 1204 can be rotatable with respect to the housing 128 and/or the tubular member 132. In such an embodiment, the maintaining of the rotational position of the channel members 1202, 1206 with respect to the housing 128 and/or the tubular member 132 can prevent the twisting of the tubular member 132 which can result in the sealing of the tubular member 132 regardless of the configuration of the constructing mechanism 141.

[0080] The exterior members 1200, 1204 can comprise a variety of shapes and sizes and can include a variety of features. In some embodiments, one or both of the exterior members 1200, 1204 can be coupled to, for example, a shaft similar to the shaft 106 shown in FIG. 1. In some embodiments, for example, the distal exterior member 1204 can be coupled to a shaft 106, including, for example, can be non-detachably coupled to the shaft 106. In some embodiments, one or both of the exterior members can include one or several features configured to facilitate coupling with the valve 104. These one or several features can include, for example, one or several male or female connectors; couplers; attachment mechanisms; or the like. In some embodiments, these one or several features can facilitate use of the valve with other existing components, instruments, tools, or the like. In some embodiments, for example, one or both of the exterior members 1200, 1204 can comprise either a male or female luer fitting, and specifically as shown in FIG. 12, the distal exterior member 1204 can comprise a male luer fitting 1210.

[0081] Several aspects of the present technology are set forth in the following examples.

[0082] 1. A hemostatic valve for sealing a medical device, the hemostatic valve comprising:

[0083] an elongate member having a first end, a second end, and a central lumen extending therebetween, wherein the elongate member is pliable;

[0084] a reinforcement structure extending along at least a portion of the elongate member, wherein the reinforcement structure is coupled to the elongate member; and

[0085] an active tensioning mechanism coupled to the elongate member, wherein the tensioning mechanism is moveable between a first configuration wherein the central lumen is constricted and sealed and a second configuration wherein the central lumen is open.

[0086] 2. The hemostatic valve of example 1, wherein the elongate member comprises a compliant polymer tube.

[0087] 3. The hemostatic valve of example 1 or 2, wherein the tensioning mechanism comprises at least one filament extending at least partially around the elongate member.

[0088] 4. The hemostatic valve of example 3, wherein the reinforcement structure is positioned between the at least one filament and the elongate member.

[0089] 5. The hemostatic valve of example 4, wherein the reinforcement structure comprises a braided mesh.

[0090] 6. The hemostatic valve of example 4 or 5, wherein the reinforcement structure is coupled to the elongate member at a position proximate to the first end of the elongate member and at a position proximate to the second end of the elongate member.

[0091] 7. The hemostatic valve of example 6, wherein the reinforcement structure is not coupled to the elongate member at a position between the first end of the elongate member and the second end of the elongate member.

[0092] 8. The hemostatic valve of any one of examples 3-7, wherein the tensioning mechanism comprises an actuator coupled to the at least one filament, wherein the actuator is moveable to control movement of the at least one filament from a first position wherein the central lumen is constricted and sealed to a second position wherein the central lumen is open, wherein the at least one filament is in the first position when the tensioning mechanism is in the first configuration.

- [0093] 9. The hemostatic valve of example 8, wherein the actuator is biased towards the first position.
- [0094] 10. The hemostatic valve of example 8 or 9, wherein the actuator is biased toward the second position.
- [0095] 11. The hemostatic valve of any one of examples 8-10, wherein the actuator comprises a manual actuator.
- [0096] 12. The hemostatic valve of any one of examples 8-11, wherein the at least one filament forms a loop around the elongate member.
- [0097] 13. The hemostatic valve of any one of examples 8-12, wherein the at least one filament forms a bight around a portion of the elongate member.
- [0098] 14. The hemostatic valve of any one of examples 8-13, wherein the at least one filament comprises a first filament and a second filament, wherein each of the first filament and the second filament are coupled to the actuator, and wherein the first filament and the second filament are moveable from the first position to the second position.
- [0099] 15. The hemostatic valve of example 14, wherein each of the first filament and the second filament form a loop around the elongate member.
- [0100] 16. The hemostatic valve of example 14 or 15, wherein the first filament forms a first bight around a first portion of the elongate member, and wherein the second filament forms a second bight around a second portion of the elongate member.
- [0101] 17. The hemostatic valve of example 16, wherein the first bight extends through the second bight.
- [0102] 18. The hemostatic valve of any one of examples 1-17, further comprising a shell defining a first aperture and a second aperture, wherein the elongate member extends from the first aperture to the second aperture and fluidly couples the first aperture and the second aperture.
- [0103] 19. The hemostatic valve of any one of examples 1-18, wherein the tensioning mechanism is self-adjustable to seal around tools of different sizes extending through the hemostatic valve.
- [0104] 20. The hemostatic valve of any one of examples 1-19, wherein the central lumen comprises a single lumen.
- [0105] 21. The hemostatic valve of any one of examples 1-20, wherein the central lumen comprises a plurality of lumens.
- [0106] 22. A delivery system for intravascular access of a blood vessel within a patient's body, the delivery system comprising:
- [0107] a catheter having a first end, a second end, and a catheter lumen extending therebetween;
  - [0108] a hemostatic valve coupled to the first end of the catheter, the hemostatic valve comprising:
    - [0109] a tubular member having a first end, a second end, and a central lumen extending therebetween, wherein the central lumen of the tubular member is fluidly coupled with the catheter lumen; and
    - [0110] an active tensioning mechanism coupled to the tubular member, the tensioning mechanism moveable between a first configuration wherein the tensioning mechanism constricts on the central lumen and the central lumen is sealed and a second configuration wherein the central lumen is open.
- [0111] 23. The delivery system of example 22, wherein the hemostatic valve further comprises a reinforcement structure extending along at least a portion of the tubular member.
- [0112] 24. The delivery system of example 22 or 23, wherein the reinforcement structure is located between the tensioning mechanism and the tubular member.
- [0113] 25. The delivery system of example 24, wherein the reinforcement structure comprises a braided mesh.
- [0114] 26. The delivery system of example 24 or 25, wherein the reinforcement structure is coupled to the tubular member at a position proximate to the first end of the tubular member and at a position proximate to the second end of the tubular member.
- [0115] 27. The delivery system of example 26, wherein the reinforcement structure is adhered to the tubular member at the first end of the tubular member and at the second end of the tubular member.
- [0116] 28. The delivery system of example 27, wherein the reinforcement structure is uncoupled to the tubular member between the first end of the tubular member and the second end of the tubular member.
- [0117] 29. The delivery system of any one of examples 22-28, wherein the tensioning mechanism comprises at least one filament extending at least partially around the tubular member.
- [0118] 30. The delivery system of example 29, wherein the tensioning mechanism comprises an actuator coupled to the at least one filament, wherein moving the tensioning mechanism from the first configuration to the second configuration comprises moving the actuator and the thereto coupled at least one filament from a first position to a second position, wherein the filament constricts and seals the central lumen of the tubular member when the filament is in the first position.
- [0119] 31. The delivery system of example 30, wherein the actuator comprises a manual actuator.
- [0120] 32. The delivery system of example 31, wherein the actuator comprises a pair of opposing and depressable buttons, wherein the buttons are biased towards an undepressed position.
- [0121] 33. The delivery system of example 31 or 32, wherein the central lumen is sealed when the buttons are in the undepressed position.
- [0122] 34. The delivery system of any one of examples 30-33, wherein the filament comprises a monofilament.
- [0123] 35. The delivery system of any one of examples 30-34, wherein the filament comprises at least one of: a polymer filament; or a metallic filament.
- [0124] 36. The delivery system of any one of examples 22-35, wherein the catheter comprises a thrombus extraction device.
- [0125] 37. A method of sealing a delivery device accessing a blood vessel of a patient, the method comprising:
- [0126] inserting the delivery device comprising a catheter and a hemostatic valve into the blood vessel of the patient, the catheter having a first end, a second end, and a catheter lumen extending therethrough, and the hemostatic valve coupled to the first end and having a tubular member defining a central lumen fluidly coupled with the catheter lumen and a tensioning mechanism coupled with the tubular member, wherein the tensioning mechanism collapses and seals the central lumen in a first configuration and thereby seals access to the blood vessel;
  - [0127] moving the tensioning mechanism of the hemostatic valve to a second configuration, wherein the

central lumen is open and access to the blood vessel is unsealed when the tensioning mechanism is in the second configuration;

[0128] advancing a shaft of a tool through the delivery device until a first end of the tool reaches a desired position within the blood vessel of the patient and a portion of the shaft is positioned within the central lumen of the tubular member; and

[0129] returning the tensioning mechanism of the hemostatic valve to the first configuration such that the tubular member collapses on the shaft of the tool and seals around the shaft of the tool.

[0130] 38. The method of example 37, further comprising retracting the shaft of the tool from the delivery device.

[0131] 39. The method of example 38, wherein the tensioning mechanism is maintained in the first configuration during and after the retracting of the shaft of the tool from the delivery device.

[0132] 40. The method of example 38 or 39, wherein the tensioning mechanism is moved to the second configuration during the retracting of the shaft of the tool from the delivery device, and wherein the tensioning mechanism is returned to the first configuration after the shaft of the tool is retracted from the delivery device.

[0133] 41. The method of any one of examples 37-40, wherein the tensioning mechanism comprises at least one filament extending at least partially around the tubular member, wherein the at least one filament collapses the tubular member when the tensioning mechanism is in the first configuration.

[0134] 42. The method of example 41, wherein the at least one filament circumferentially constricts the tubular member to collapse the tubular member when the tensioning mechanism is in the first configuration.

[0135] 43. The method of example 41 or 42, wherein the hemostatic valve comprises a reinforcement structure located between the at least one filament and the tubular member.

[0136] 44. The method of any one of examples 41-43, wherein the at least one filament forms a loop around the elongate member, and wherein moving the tensioning mechanism from the second configuration to the first configuration reduces a size of the loop to thereby constrict the tubular member within the loop.

[0137] 45. The method of any one of examples 41-44, wherein the filament forms at least one bight around a portion of the elongate member.

[0138] 46. The method of example 45, wherein the filament comprises a first filament and a second filament, and wherein the at least one bight comprises a first bight oriented in a first direction and formed by the first filament and a second bight oriented in a second direction and formed by the second filament, wherein the first and second bights overlap to encircle a portion of the tubular member within an constricting area.

[0139] 47. The method of example 46, wherein moving the tensioning mechanism from the second configuration to the first configuration comprises moving the first bight in the first direction and the second bight in the direction to reduce the size of the constricting area and collapse and seal the central lumen of the tubular member.

[0140] 48. The method of any one of examples 37-47, wherein the tensioning mechanism comprises an actuator,

and wherein moving the tensioning mechanism to the second configuration comprises manipulating the actuator.

[0141] 49. The method of any one of examples 37-48, further comprising applying a vacuum to the delivery device to aspirate material through the catheter, wherein the central lumen remains sealed during the aspiration.

[0142] 50. The method of any one of examples 37-49, wherein the tool comprises a thrombus extraction device.

[0143] 51. A hemostatic valve for sealing a medical device, the hemostatic valve comprising:

[0144] an elongate member having a first end, a second end, and a central lumen comprising a plurality of lumens extending therebetween, wherein the elongate member is pliable; and

[0145] an active tensioning mechanism coupled to the elongate member, wherein the tensioning mechanism is moveable between a first configuration wherein the central lumen is constricted and sealed and a second configuration wherein the central lumen is open.

[0146] Other variations are within the spirit of the present invention. Thus, while the invention is susceptible to various modifications and alternative constructions, certain illustrated embodiments thereof are shown in the drawings and have been described above in detail. It should be understood, however, that there is no intention to limit the invention to the specific form or forms disclosed, but on the contrary, the intention is to cover all modifications, alternative constructions, and equivalents falling within the spirit and scope of the invention, as defined in the appended claims.

[0147] In the previous description, various embodiments of the present invention are described. For purposes of explanation, specific configurations and details are set forth in order to provide a thorough understanding of the embodiments. However, it will also be apparent to one skilled in the art that the present invention may be practiced without the specific details. Furthermore, well-known features may be omitted or simplified in order not to obscure the embodiment being described.

[0148] The use of the terms “a” and “an” and “the” and similar referents in the context of describing the invention (especially in the context of the following claims) are to be construed to cover both the singular and the plural, unless otherwise indicated herein or clearly contradicted by context. The terms “comprising,” “having,” “including,” and “containing” are to be construed as open-ended terms (i.e., meaning “including, but not limited to,”) unless otherwise noted. The term “connected” is to be construed as partly or wholly contained within, attached to, or joined together, even if there is something intervening. Recitation of ranges of values herein are merely intended to serve as a shorthand method of referring individually to each separate value falling within the range, unless otherwise indicated herein, and each separate value is incorporated into the specification as if it were individually recited herein. All methods described herein can be performed in any suitable order unless otherwise indicated herein or otherwise clearly contradicted by context. The use of any and all examples, or exemplary language (e.g., “such as”) provided herein, is intended merely to better illuminate embodiments of the invention and does not pose a limitation on the scope of the invention unless otherwise claimed. No language in the specification should be construed as indicating any non-claimed element as essential to the practice of the invention.

**[0149]** Preferred embodiments of this invention are described herein, including the best mode known to the inventors for carrying out the invention. Variations of those preferred embodiments may become apparent to those of ordinary skill in the art upon reading the foregoing description. The inventors expect skilled artisans to employ such variations as appropriate, and the inventors intend for the invention to be practiced otherwise than as specifically described herein. Accordingly, this invention includes all modifications and equivalents of the subject matter recited in the claims appended hereto as permitted by applicable law. Moreover, any combination of the above-described elements in all possible variations thereof is encompassed by the invention unless otherwise indicated herein or otherwise clearly contradicted by context.

**[0150]** All references, including publications, patent applications, and patents, cited herein are hereby incorporated by reference to the same extent as if each reference were individually and specifically indicated to be incorporated by reference and were set forth in its entirety herein.

What is claimed is:

1. A valve assembly, comprising:

- a tubular member defining a lumen;
- a first filament extending in a first loop around the tubular member, wherein the first filament is flexible;
- a second filament extending in a second loop around the tubular member, wherein the second filament is flexible;
- a pair of actuators movable from a first position to a second position, wherein—
  - the first filament includes a first portion operably acted upon by a first one of the actuators and a second portion operably acted upon by a second one of the actuators;
  - the second filament includes a first portion operably acted upon by the first one of the actuators and a second portion operably acted upon by the second one of the actuators;
  - in the first position, the actuators are positioned to tension the first filament and the second filament thereby decreasing a dimension of the first loop and a dimension of the second loop to constrict the lumen of the tubular member;
  - in the second position, the actuators are positioned to loosen the first filament and the second filament thereby permitting the tubular member to expand against the first loop and the second loop to increase the dimension of the first loop and the dimension of the second loop to at least partially open the lumen of the tubular member; and
  - the actuators are biased to the first position.

2. The valve assembly of claim 1 wherein the first loop extends completely around the tubular member, and wherein the second loop extends completely around the tubular member.

3. The valve assembly of claim 1 wherein the first portion of the first filament is a first end portion of the first filament, wherein the second portion of the first filament is a second end portion of the first filament, wherein the first portion of the second filament is a first end portion of the second filament, and wherein the second portion of the second filament is a second end portion of the second filament.

4. The valve assembly of claim 3 wherein the first end portion of first filament is directly attached to the first one of

the actuators, wherein the second end portion of the first filament is directly attached to the second one of the actuators, wherein the first end portion of the second filament is directly attached to the first one of the actuators, and wherein the second end portion of the second filament is directly attached to the second one of the actuators.

5. The valve assembly of claim 1 wherein the tubular member extends along a longitudinal axis, and wherein the first loop is proximate to the second loop along the longitudinal axis.

6. The valve assembly of claim 1 wherein the first filament and the second filament each comprise a plurality of strands woven together.

7. The valve assembly of claim 1 wherein the tubular member is elastically deformable.

8. The valve assembly of claim 1 wherein the tubular member is configured to resiliently expand.

9. The valve assembly of claim 1, further comprising a rigid housing, wherein the tubular member, the first filament, and the second filament are positioned within the housing, and wherein the actuators are movably coupled to the housing.

10. The valve assembly of claim 1 wherein the actuators are depressed toward one another in the second position, and wherein the actuators are moved away from one another in the first position.

11. The valve assembly of claim 1 wherein, in the second position, the tubular member has a diameter of at least 14 French.

12. The valve assembly of claim 1 wherein, in the second position, the tubular member has a diameter of at least 16 French.

13. The valve assembly of claim 1 wherein, in the second position, the tubular member has a diameter of at least 20 French.

14. The valve assembly of claim 1 wherein, in the second position, the tubular member has a diameter of at least 24 French.

15. A valve assembly, comprising:

- a tubular member defining a lumen, wherein the tubular member is elastically deformable from a first position in which the lumen is constricted to a second position in which the lumen is at least partially open;
- a first actuator;
- a second actuator;
- a first filament configured in a first loop completely around the tubular member and having a first portion extending from the first loop toward the first actuator and a second portion extending from the first loop toward the second actuator; and
- a second filament configured in a second loop completely around the tubular member and having a first portion extending from the second loop toward the first actuator and a second portion extending from the second loop toward the second actuator;

wherein—

the first actuator and the second actuator are biased away from one another to elastically deform the tubular member to the first position by (a) increasing a tension in the first filament to decrease a dimension of the first loop and (b) increasing a tension in the second filament to decrease a dimension of the second loop; and

the first actuator and the second actuator are movable toward one another to permit the tubular member to return to the second position by (a) decreasing the tension in the first filament and (b) decreasing the tension in the second filament.

**16.** The valve assembly of claim **15** wherein the first actuator and the second actuator each comprise a button.

**17.** The valve assembly of claim **15** wherein the first filament is flexible, and wherein the second filament is flexible.

**18.** The valve assembly of claim **15** wherein the first portion of first filament is directly attached to the first actuator, wherein the second portion of the first filament is directly attached to the second actuator, wherein the first portion of the second filament is directly attached to the first actuator, and wherein the second portion of the second filament is directly attached to the second actuator.

**19.** The valve assembly of claim **15** wherein the tubular member extends along a longitudinal axis, wherein the first portion of the first filament extends toward the first actuator along a first axis extending generally orthogonal to the longitudinal axis proximate the tubular member, wherein the second portion of the first filament extends toward the second actuator along a second axis extending generally orthogonal to the longitudinal axis proximate the tubular member, wherein the first portion of the second filament extends toward the first actuator along a third axis extending generally orthogonal to the longitudinal axis proximate the tubular member, wherein the second portion of the second filament extends toward the second actuator along a fourth axis extending generally orthogonal to the longitudinal axis proximate the tubular member, wherein the second axis is positioned between the first axis and the fourth axis, and wherein the fourth axis is positioned between the second axis and the third axis.

**20.** The valve assembly of claim **15** wherein, in the second position, the tubular member has a diameter of at least 16 French.

**21.** The valve assembly of claim **15** wherein, in the second position, the tubular member has a diameter of at least 20 French.

**22.** The valve assembly of claim **15** wherein, in the second position, the tubular member has a diameter of at least 24 French.

**23.** A valve assembly, comprising:  
 a tubular member defining a lumen;  
 a first filament extending in a first loop around the tubular member;  
 a second filament extending in a second loop around the tubular member; and  
 a pair of actuators biased to circumferentially constrict the first loop and the second loop to elastically deform the tubular member to a first position in which the lumen is constricted, wherein at least one the actuators is movable to decrease a level of tension in the first filament and a level of tension in the second filament to permit the tubular member to expand against the first loop and the second loop to a second position in which the lumen of the tubular member is at least partially open.

**24.** The valve assembly of claim **23** wherein the actuators each comprise a button.

**25.** The valve assembly of claim **23** wherein the first filament includes a first portion operably coupled to a first one of the actuators and a second portion operably coupled to a second one of the actuators, and wherein the second filament includes a first portion operably coupled to the first one of the actuators and a second portion operably coupled to the second one of the actuators.

**26.** The valve assembly of claim **25** wherein the first portion of first filament is directly attached to the first one of the actuators, wherein the second portion of the first filament is directly attached to the second one of the actuators, wherein the first portion of the second filament is directly attached to the first one of the actuators, and wherein the second portion of the second filament is directly attached to the second one of the actuators.

**27.** The valve assembly of claim **23** wherein the first filament is flexible, and wherein the second filament is flexible.

**28.** The valve assembly of claim **23** wherein, in the second position, the tubular member has a diameter of at least 16 French.

**29.** The valve assembly of claim **23** wherein, in the second position, the tubular member has a diameter of at least 20 French.

**30.** The valve assembly of claim **23** wherein, in the second position, the tubular member has a diameter of at least 24 French.

\* \* \* \* \*