



US011051836B2

(12) **United States Patent**
Shelton, IV et al.

(10) **Patent No.:** **US 11,051,836 B2**
(45) **Date of Patent:** **Jul. 6, 2021**

(54) **SURGICAL CLIP APPLIER COMPRISING AN EMPTY CLIP CARTRIDGE LOCKOUT**

(2013.01); *A61B 17/06133* (2013.01); *A61B 17/105* (2013.01); *A61B 17/128* (2013.01);
(Continued)

(71) Applicant: **Ethicon LLC**, Guaynabo, PR (US)

(58) **Field of Classification Search**

(72) Inventors: **Frederick E. Shelton, IV**, Hillsboro, OH (US); **Andrew C. Deck**, Blue Ash, OH (US); **Jason L. Harris**, Lebanon, OH (US)

CPC A61B 17/10; A61B 17/068; A61B 17/128; A61B 17/34; A61B 34/30; A61B 17/00; A61B 17/0469; A61B 17/0482; A61B 17/0483; A61B 17/0491; A61B 17/06004; A61B 17/06066; A61B 17/06144; A61B 17/06133; A61B 17/062; A61B 17/0625; A61B 17/105; A61B 17/1285

(73) Assignee: **Cilag GmbH International**, Zug (CH)

See application file for complete search history.

(*) Notice: Subject to any disclaimer, the term of this patent is extended or adjusted under 35 U.S.C. 154(b) by 77 days.

(56) **References Cited**

(21) Appl. No.: **16/112,245**

U.S. PATENT DOCUMENTS

(22) Filed: **Aug. 24, 2018**

1,853,416 A 4/1932 Hall
3,082,426 A 3/1963 Miles

(65) **Prior Publication Data**

US 2019/0125352 A1 May 2, 2019

(Continued)

Related U.S. Application Data

FOREIGN PATENT DOCUMENTS

(60) Provisional application No. 62/578,793, filed on Oct. 30, 2017, provisional application No. 62/578,804, (Continued)

AU 2015201140 A1 3/2015
CA 2795323 A1 5/2014

(Continued)

OTHER PUBLICATIONS

(51) **Int. Cl.**
A61B 17/29 (2006.01)
A61B 18/14 (2006.01)

US 10,504,709, 8/2018, Karancsi et al. (withdrawn).
(Continued)

(Continued)

Primary Examiner — George J Ulsh

(52) **U.S. Cl.**
CPC *A61B 17/2909* (2013.01); *A61B 17/00* (2013.01); *A61B 17/0469* (2013.01); *A61B 17/0482* (2013.01); *A61B 17/0483* (2013.01); *A61B 17/0491* (2013.01); *A61B 17/062* (2013.01); *A61B 17/06004* (2013.01); *A61B 17/068* (2013.01); *A61B 17/0625* (2013.01); *A61B 17/06066* (2013.01); *A61B 17/06114*

(57) **ABSTRACT**

A surgical clip applier comprising a rotatable clip cartridge is disclosed. The surgical clip applier comprises a lockout that at least locks out the crimping drive of the surgical clip applier when the rotatable clip cartridge is empty.

20 Claims, 68 Drawing Sheets

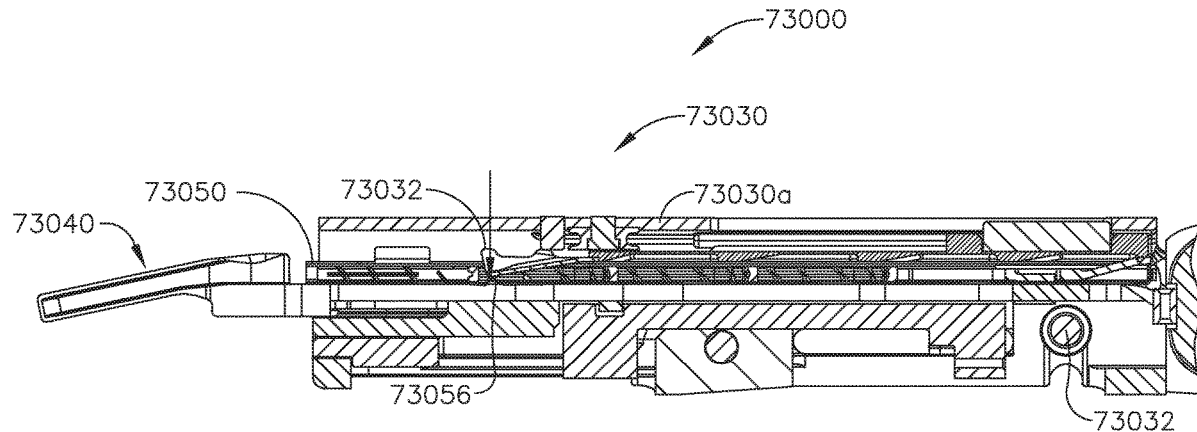

Related U.S. Application Data

filed on Oct. 30, 2017, provisional application No. 62/578,817, filed on Oct. 30, 2017, provisional application No. 62/578,835, filed on Oct. 30, 2017, provisional application No. 62/578,844, filed on Oct. 30, 2017, provisional application No. 62/578,855, filed on Oct. 30, 2017, provisional application No. 62/665,129, filed on May 1, 2018, provisional application No. 62/665,139, filed on May 1, 2018, provisional application No. 62/665,177, filed on May 1, 2018, provisional application No. 62/665,128, filed on May 1, 2018, provisional application No. 62/665,192, filed on May 1, 2018, provisional application No. 62/665,134, filed on May 1, 2018.

(51) **Int. Cl.**

A61B 17/04 (2006.01)
A61B 17/06 (2006.01)
A61B 18/12 (2006.01)
A61B 34/30 (2016.01)
A61B 17/00 (2006.01)
A61B 17/128 (2006.01)
A61B 90/98 (2016.01)
A61B 17/062 (2006.01)
A61B 17/068 (2006.01)
A61B 17/28 (2006.01)
A61B 17/285 (2006.01)
A61B 17/295 (2006.01)
A61B 90/00 (2016.01)
A61B 17/10 (2006.01)
A61B 17/34 (2006.01)
G06F 3/147 (2006.01)
A61B 34/00 (2016.01)
A61B 18/00 (2006.01)
A61B 17/32 (2006.01)
B33Y 80/00 (2015.01)
A61B 17/3201 (2006.01)
F16D 27/108 (2006.01)
F16D 27/12 (2006.01)
G09G 3/34 (2006.01)
G09G 3/36 (2006.01)
G09G 3/38 (2006.01)
F16D 27/00 (2006.01)

(52) **U.S. Cl.**

CPC *A61B 17/1285* (2013.01); *A61B 17/282* (2013.01); *A61B 17/285* (2013.01); *A61B 17/2841* (2013.01); *A61B 17/29* (2013.01); *A61B 17/295* (2013.01); *A61B 17/3421* (2013.01); *A61B 17/3468* (2013.01); *A61B 18/1206* (2013.01); *A61B 18/1445* (2013.01); *A61B 34/30* (2016.02); *A61B 34/76* (2016.02); *A61B 90/03* (2016.02); *A61B 90/98* (2016.02); *G06F 3/147* (2013.01); *A61B 17/2833* (2013.01); *A61B 17/3201* (2013.01); *A61B 2017/0003* (2013.01); *A61B 2017/00017* (2013.01); *A61B 2017/00026* (2013.01); *A61B 2017/00039* (2013.01); *A61B 2017/0046* (2013.01); *A61B 2017/00057* (2013.01); *A61B 2017/00061* (2013.01); *A61B 2017/00075* (2013.01); *A61B 2017/00115* (2013.01); *A61B 2017/00119* (2013.01); *A61B 2017/00128* (2013.01); *A61B 2017/00212* (2013.01); *A61B 2017/00221* (2013.01); *A61B 2017/00327* (2013.01); *A61B 2017/00367* (2013.01); *A61B 2017/00393* (2013.01); *A61B 2017/00398*

(2013.01); *A61B 2017/00407* (2013.01); *A61B 2017/00424* (2013.01); *A61B 2017/00438* (2013.01); *A61B 2017/00464* (2013.01); *A61B 2017/00473* (2013.01); *A61B 2017/00477* (2013.01); *A61B 2017/00526* (2013.01); *A61B 2017/00734* (2013.01); *A61B 2017/06052* (2013.01); *A61B 2017/06076* (2013.01); *A61B 2017/2825* (2013.01); *A61B 2017/2845* (2013.01); *A61B 2017/2902* (2013.01); *A61B 2017/2903* (2013.01); *A61B 2017/2911* (2013.01); *A61B 2017/2923* (2013.01); *A61B 2017/2925* (2013.01); *A61B 2017/2926* (2013.01); *A61B 2017/2927* (2013.01); *A61B 2017/2929* (2013.01); *A61B 2017/2931* (2013.01); *A61B 2017/2943* (2013.01); *A61B 2017/2945* (2013.01); *A61B 2017/320044* (2013.01); *A61B 2018/0063* (2013.01); *A61B 2018/0072* (2013.01); *A61B 2018/00077* (2013.01); *A61B 2018/00083* (2013.01); *A61B 2018/00136* (2013.01); *A61B 2018/00178* (2013.01); *A61B 2018/00208* (2013.01); *A61B 2018/00404* (2013.01); *A61B 2018/00577* (2013.01); *A61B 2018/00595* (2013.01); *A61B 2018/00601* (2013.01); *A61B 2018/00642* (2013.01); *A61B 2018/00672* (2013.01); *A61B 2018/00678* (2013.01); *A61B 2018/00696* (2013.01); *A61B 2018/00702* (2013.01); *A61B 2018/00708* (2013.01); *A61B 2018/00767* (2013.01); *A61B 2018/00827* (2013.01); *A61B 2018/00875* (2013.01); *A61B 2018/00892* (2013.01); *A61B 2018/126* (2013.01); *A61B 2018/1253* (2013.01); *A61B 2018/1266* (2013.01); *A61B 2018/146* (2013.01); *A61B 2018/1452* (2013.01); *A61B 2018/1457* (2013.01); *A61B 2090/035* (2016.02); *A61B 2090/0811* (2016.02); *B33Y 80/00* (2014.12); *F16D 27/004* (2013.01); *F16D 27/108* (2013.01); *F16D 27/12* (2013.01); *G09G 3/344* (2013.01); *G09G 3/3648* (2013.01); *G09G 3/38* (2013.01); *G09G 2380/08* (2013.01)

(56)

References Cited

U.S. PATENT DOCUMENTS

3,503,396	A	3/1970	Pierie et al.
3,584,628	A	6/1971	Green
3,633,584	A	1/1972	Farrell
3,759,017	A	9/1973	Young
4,412,539	A	11/1983	Jarvik
4,448,193	A	5/1984	Ivanov
4,523,695	A	6/1985	Braun et al.
4,608,160	A	8/1986	Zoch
4,614,366	A	9/1986	North et al.
4,701,193	A	10/1987	Robertson et al.
4,735,603	A	4/1988	Goodson et al.
4,788,977	A	12/1988	Farin et al.
4,892,244	A	1/1990	Fox et al.
5,035,692	A	7/1991	Lyon et al.
5,042,460	A	8/1991	Sakurai et al.
5,084,057	A	1/1992	Green et al.
5,100,402	A	3/1992	Fan
5,129,570	A	7/1992	Schulze et al.
5,151,102	A	9/1992	Kamiyama et al.
5,156,315	A	10/1992	Green et al.
5,158,585	A	10/1992	Saho et al.
5,197,962	A	3/1993	Sansom et al.
5,242,474	A	9/1993	Herbst et al.
5,253,793	A	10/1993	Green et al.

(56)

References Cited

U.S. PATENT DOCUMENTS

5,271,543	A	12/1993	Grant et al.	6,079,606	A	6/2000	Milliman et al.
RE34,519	E	1/1994	Fox et al.	6,090,107	A	7/2000	Borgmeier et al.
5,318,516	A	6/1994	Cosmescu	6,099,537	A	8/2000	Sugai et al.
5,322,055	A	6/1994	Davison et al.	6,109,500	A	8/2000	Alli et al.
5,342,349	A	8/1994	Kaufman	6,155,473	A	12/2000	Tompkins et al.
5,383,880	A	1/1995	Hooven	6,214,000	B1	4/2001	Fleenor et al.
5,396,900	A	3/1995	Slater et al.	6,258,105	B1	7/2001	Hart et al.
5,397,046	A	3/1995	Savage et al.	6,273,887	B1	8/2001	Yamauchi et al.
5,403,312	A	4/1995	Yates et al.	6,301,495	B1	10/2001	Gueziec et al.
5,403,327	A	4/1995	Thornton et al.	6,302,881	B1	10/2001	Farin
5,413,267	A	5/1995	Solyntjes et al.	6,308,089	B1	10/2001	von der Ruhr et al.
5,415,335	A	5/1995	Knodell, Jr.	6,325,808	B1	12/2001	Bernard et al.
5,417,699	A	5/1995	Klein et al.	6,325,811	B1	12/2001	Messerly
5,439,468	A	8/1995	Schulze et al.	6,341,164	B1	1/2002	Dilkie et al.
5,445,304	A	8/1995	Plyley et al.	6,391,102	B1	5/2002	Bodden et al.
5,465,895	A	11/1995	Knodel et al.	6,434,416	B1	8/2002	Mizoguchi et al.
5,467,911	A	11/1995	Tsuruta et al.	6,443,973	B1	9/2002	Whitman
5,474,566	A	12/1995	Alesi et al.	6,454,781	B1	9/2002	Witt et al.
5,485,947	A	1/1996	Olson et al.	6,457,625	B1	10/2002	Tormala et al.
5,496,315	A	3/1996	Weaver et al.	6,461,352	B2	10/2002	Morgan et al.
5,503,320	A	4/1996	Webster et al.	6,530,933	B1	3/2003	Yeung et al.
5,531,743	A	7/1996	Nettekoven et al.	6,551,243	B2	4/2003	Bocionek et al.
5,545,148	A	8/1996	Wurster	6,569,109	B2	5/2003	Sakurai et al.
5,584,425	A	12/1996	Savage et al.	6,582,424	B2	6/2003	Fleenor et al.
5,610,379	A	3/1997	Muz et al.	6,585,791	B1	7/2003	Garito et al.
5,613,966	A	3/1997	Makower et al.	6,618,626	B2	9/2003	West, Jr. et al.
5,624,452	A	4/1997	Yates	6,648,223	B2	11/2003	Boukhny et al.
5,626,587	A	5/1997	Bishop et al.	6,685,704	B2	2/2004	Greep
5,643,291	A	7/1997	Pier et al.	6,699,187	B2	3/2004	Webb et al.
5,654,750	A	8/1997	Weil et al.	6,742,895	B2	6/2004	Robin
5,673,841	A	10/1997	Schulze et al.	6,752,816	B2	6/2004	Culp et al.
5,673,842	A	10/1997	Bittner et al.	6,773,444	B2	8/2004	Messerly
5,675,227	A	10/1997	Roos et al.	6,775,575	B2	8/2004	Bommannan et al.
5,693,052	A	12/1997	Weaver	6,778,846	B1	8/2004	Martinez et al.
5,695,502	A	* 12/1997	Pier A61B 17/1285 606/143	6,781,683	B2	8/2004	Kacyra et al.
5,697,926	A	12/1997	Weaver	6,783,524	B2	8/2004	Anderson et al.
5,706,998	A	1/1998	Plyley et al.	6,783,525	B2	8/2004	Greep et al.
5,718,359	A	2/1998	Palmer et al.	6,783,525	B2	8/2004	Greep et al.
5,725,536	A	3/1998	Oberlin et al.	6,793,663	B2	9/2004	Kneifel et al.
5,725,542	A	3/1998	Yoon	6,846,308	B2	1/2005	Whitman et al.
5,735,445	A	4/1998	Vidal et al.	6,852,219	B2	2/2005	Hammond
5,735,848	A	4/1998	Yates et al.	6,863,650	B1	3/2005	Irion
5,746,209	A	5/1998	Yost et al.	6,869,430	B2	3/2005	Balbierz et al.
5,749,362	A	5/1998	Funda et al.	6,869,435	B2	3/2005	Blake, III
5,749,893	A	5/1998	Vidal et al.	6,911,033	B2	6/2005	de Guillebon et al.
5,752,644	A	5/1998	Bolanos et al.	6,937,892	B2	8/2005	Leyde et al.
5,762,255	A	6/1998	Chrisman et al.	6,945,981	B2	9/2005	Donofrio et al.
5,766,186	A	6/1998	Faraz et al.	6,951,559	B1	10/2005	Greep
5,769,791	A	6/1998	Benaron et al.	6,978,921	B2	12/2005	Shelton, IV et al.
5,797,537	A	8/1998	Oberlin et al.	6,988,649	B2	1/2006	Shelton, IV et al.
D399,561	S	10/1998	Ellingson	7,000,818	B2	2/2006	Shelton, IV et al.
5,817,093	A	10/1998	Williamson, IV et al.	7,030,146	B2	4/2006	Baynes et al.
5,820,009	A	10/1998	Melling et al.	7,032,798	B2	4/2006	Whitman et al.
5,836,849	A	11/1998	Mathiak et al.	7,041,941	B2	5/2006	Faries, Jr. et al.
5,836,909	A	11/1998	Cosmescu	7,044,352	B2	5/2006	Shelton, IV et al.
5,843,080	A	12/1998	Fleenor et al.	7,044,911	B2	5/2006	Drinan et al.
5,846,237	A	12/1998	Nettekoven	7,048,775	B2	5/2006	Jornitz et al.
5,849,022	A	12/1998	Sakashita et al.	7,053,752	B2	5/2006	Wang et al.
5,873,873	A	2/1999	Smith et al.	7,055,730	B2	6/2006	Ehrenfels et al.
5,878,938	A	3/1999	Bittner et al.	7,077,853	B2	7/2006	Kramer et al.
5,893,849	A	4/1999	Weaver	7,077,856	B2	7/2006	Whitman
5,906,625	A	5/1999	Bitto et al.	7,081,096	B2	7/2006	Brister et al.
5,942,333	A	8/1999	Arnett et al.	7,097,640	B2	8/2006	Wang et al.
5,947,996	A	9/1999	Logeman	7,103,688	B2	9/2006	Strong
5,968,032	A	10/1999	Sleister	7,118,564	B2	10/2006	Ritchie et al.
5,980,510	A	11/1999	Tsonton et al.	7,121,460	B1	10/2006	Parsons et al.
5,997,528	A	12/1999	Bisch et al.	7,137,980	B2	11/2006	Byusse et al.
6,010,054	A	1/2000	Johnson et al.	7,140,528	B2	11/2006	Shelton, IV
6,030,437	A	2/2000	Gourrier et al.	7,143,923	B2	12/2006	Shelton, IV et al.
6,036,637	A	3/2000	Kudo	7,143,925	B2	12/2006	Shelton, IV et al.
6,039,734	A	3/2000	Goble	7,147,139	B2	12/2006	Schwemberger et al.
6,039,735	A	3/2000	Greep	7,155,316	B2	12/2006	Sutherland et al.
6,059,799	A	5/2000	Aranyi et al.	7,169,145	B2	1/2007	Isaacson et al.
6,066,137	A	5/2000	Greep	7,177,533	B2	2/2007	McFarlin et al.
				7,182,775	B2	2/2007	De Guillebon et al.
				7,208,005	B2	4/2007	Frecker et al.
				7,230,529	B2	6/2007	Ketcherside, Jr. et al.
				7,232,447	B2	6/2007	Gellman et al.
				7,236,817	B2	6/2007	Papas et al.
				7,246,734	B2	7/2007	Shelton, IV

(56)

References Cited

U.S. PATENT DOCUMENTS

7,278,563	B1	10/2007	Green	7,980,443	B2	7/2011	Scheib et al.
7,294,106	B2	11/2007	Birkenbach et al.	7,982,776	B2	7/2011	Dunki-Jacobs et al.
7,294,116	B1	11/2007	Ellman et al.	7,988,028	B2	8/2011	Farascioni et al.
7,296,724	B2	11/2007	Green et al.	7,993,140	B2	8/2011	Sakezles
7,317,955	B2	1/2008	McGreevy	7,995,045	B2	8/2011	Dunki-Jacobs
7,328,828	B2	2/2008	Ortiz et al.	8,005,947	B2	8/2011	Morris et al.
7,334,717	B2	2/2008	Rethy et al.	8,007,494	B1	8/2011	Taylor et al.
7,343,565	B2	3/2008	Ying et al.	8,007,513	B2	8/2011	Nalagatla et al.
7,362,228	B2	4/2008	Nycz et al.	8,010,180	B2	8/2011	Quaid et al.
7,371,227	B2	5/2008	Zeiner	8,012,170	B2	9/2011	Whitman et al.
7,380,695	B2	6/2008	Doll et al.	8,015,976	B2	9/2011	Shah
7,383,088	B2	6/2008	Spinelli et al.	8,016,855	B2	9/2011	Whitman et al.
7,391,173	B2	6/2008	Schena	8,025,199	B2	9/2011	Whitman et al.
7,407,074	B2	8/2008	Ortiz et al.	8,027,710	B1	9/2011	Dannan
7,422,139	B2	9/2008	Shelton, IV et al.	8,035,685	B2	10/2011	Jensen
7,423,972	B2	9/2008	Shaham et al.	8,038,686	B2	10/2011	Huitema et al.
7,457,804	B2	11/2008	Uber, III et al.	8,038,693	B2	10/2011	Allen
7,464,847	B2	12/2008	Viola et al.	8,043,560	B2	10/2011	Okumoto et al.
7,464,849	B2	12/2008	Shelton, IV et al.	8,054,184	B2	11/2011	Cline et al.
7,515,961	B2	4/2009	Germanson et al.	8,054,752	B2	11/2011	Druke et al.
7,575,144	B2	8/2009	Ortiz et al.	8,062,306	B2	11/2011	Nobis et al.
7,617,137	B2	11/2009	Kreiner et al.	8,062,330	B2	11/2011	Prommersberger et al.
7,621,192	B2	11/2009	Conti et al.	8,066,721	B2	11/2011	Kortenbach et al.
7,621,898	B2	11/2009	Lalomia et al.	8,075,571	B2	12/2011	Vitali et al.
7,637,410	B2	12/2009	Marczyk	8,096,459	B2	1/2012	Ortiz et al.
7,641,092	B2	1/2010	Kruszynski et al.	8,118,206	B2	2/2012	Zand et al.
7,644,848	B2	1/2010	Swayze et al.	8,120,301	B2	2/2012	Goldberg et al.
7,667,839	B2	2/2010	Bates	8,123,764	B2	2/2012	Meade et al.
7,670,334	B2	3/2010	Hueil et al.	8,131,565	B2	3/2012	Dicks et al.
7,694,865	B2	4/2010	Scirica	8,136,712	B2	3/2012	Zingman
7,699,860	B2	4/2010	Huitema et al.	8,147,486	B2	4/2012	Honour et al.
7,720,306	B2	5/2010	Gardiner et al.	8,155,479	B2	4/2012	Hoffman et al.
7,721,934	B2	5/2010	Shelton, IV et al.	8,157,145	B2	4/2012	Shelton, IV et al.
7,721,936	B2	5/2010	Shalton, IV et al.	8,157,150	B2	4/2012	Viola et al.
7,736,357	B2	6/2010	Lee, Jr. et al.	8,160,098	B1	4/2012	Yan et al.
7,742,176	B2	6/2010	Braunecker et al.	8,161,977	B2	4/2012	Shelton, IV et al.
7,743,960	B2	6/2010	Whitman et al.	8,170,396	B2	5/2012	Kuspa et al.
7,753,245	B2	7/2010	Boudreaux et al.	8,172,836	B2	5/2012	Ward
7,766,207	B2	8/2010	Mather et al.	8,181,839	B2	5/2012	Beetel
7,766,905	B2	8/2010	Paterson et al.	8,185,409	B2	5/2012	Putnam et al.
7,770,773	B2	8/2010	Whitman et al.	8,206,345	B2	6/2012	Abboud et al.
7,776,037	B2	8/2010	Odom	8,210,411	B2	7/2012	Yates et al.
7,782,789	B2	8/2010	Stultz et al.	8,214,007	B2	7/2012	Baker et al.
7,784,663	B2	8/2010	Shelton, IV	8,216,849	B2	7/2012	Petty
7,803,151	B2	9/2010	Whitman	8,220,688	B2	7/2012	Laurent et al.
7,810,692	B2	10/2010	Hall et al.	8,225,643	B2	7/2012	Abboud et al.
7,818,041	B2	10/2010	Kim et al.	8,225,979	B2	7/2012	Farascioni et al.
7,819,298	B2	10/2010	Hall et al.	8,229,549	B2	7/2012	Whitman et al.
7,832,612	B2	11/2010	Baxter, III et al.	8,257,387	B2	9/2012	Cunningham
7,836,085	B2	11/2010	Petakov et al.	8,260,016	B2	9/2012	Maeda et al.
7,837,079	B2	11/2010	Holsten et al.	8,262,560	B2	9/2012	Whitman
7,837,680	B2	11/2010	Isaacson et al.	8,292,888	B2	10/2012	Whitman
7,841,980	B2	11/2010	Minosawa et al.	8,295,902	B2	10/2012	Salahieh et al.
7,845,537	B2	12/2010	Shelton, IV et al.	8,308,040	B2	11/2012	Huang et al.
7,857,185	B2	12/2010	Swayze et al.	8,321,581	B2	11/2012	Katis et al.
7,862,560	B2	1/2011	Marion	8,328,065	B2	12/2012	Shah
7,862,579	B2	1/2011	Ortiz et al.	8,335,590	B2	12/2012	Costa et al.
7,865,236	B2	1/2011	Cory et al.	8,343,065	B2	1/2013	Bartol et al.
7,887,530	B2	2/2011	Zemlok et al.	8,346,392	B2	1/2013	Walser et al.
7,892,337	B2	2/2011	Palmerton et al.	8,360,299	B2	1/2013	Zemlok et al.
7,907,166	B2	3/2011	Lamprecht et al.	8,364,222	B2	1/2013	Cook et al.
7,913,891	B2	3/2011	Doll et al.	8,365,975	B1	2/2013	Manoux et al.
7,918,230	B2	4/2011	Whitman et al.	8,388,652	B2	3/2013	Viola
7,918,377	B2	4/2011	Measamer et al.	8,393,514	B2	3/2013	Shelton, IV et al.
7,920,706	B2	4/2011	Asokan et al.	8,397,972	B2	3/2013	Kostrzewski
7,927,014	B2	4/2011	Dehler	8,398,541	B2	3/2013	DiMaio et al.
7,942,300	B2	5/2011	Rethy et al.	8,403,944	B2	3/2013	Pain et al.
7,954,682	B2	6/2011	Giordano et al.	8,403,945	B2	3/2013	Whitfield et al.
7,955,322	B2	6/2011	Devengenzo et al.	8,403,946	B2	3/2013	Whitfield et al.
7,956,620	B2	6/2011	Gilbert	8,406,859	B2	3/2013	Zuzak et al.
7,963,433	B2	6/2011	Whitman et al.	8,422,035	B2	4/2013	Hinderling et al.
7,966,269	B2	6/2011	Bauer et al.	8,423,182	B2	4/2013	Robinson et al.
7,967,180	B2	6/2011	Scirica	8,428,722	B2	4/2013	Verhoef et al.
7,976,553	B2	7/2011	Shelton, IV et al.	8,439,910	B2	5/2013	Greep et al.
7,979,157	B2	7/2011	Anvari	8,444,663	B2	5/2013	Houser et al.
				8,452,615	B2	5/2013	Abri
				8,454,506	B2	6/2013	Rothman et al.
				8,461,744	B2	6/2013	Wiener et al.
				8,468,030	B2	6/2013	Stroup et al.

(56)

References Cited

U.S. PATENT DOCUMENTS

8,469,973 B2	6/2013	Meade et al.	8,820,608 B2	9/2014	Miyamoto
8,472,630 B2	6/2013	Konrad et al.	8,827,134 B2	9/2014	Viola et al.
8,476,227 B2	7/2013	Kaplan et al.	8,840,003 B2	9/2014	Morgan et al.
8,489,235 B2	7/2013	Moll et al.	8,851,354 B2	10/2014	Swensgard et al.
8,499,992 B2	8/2013	Whitman et al.	8,852,174 B2	10/2014	Burbank
8,500,756 B2	8/2013	Papa et al.	8,875,973 B2	11/2014	Whitman
8,503,759 B2	8/2013	Greer et al.	8,882,662 B2	11/2014	Charles
8,505,801 B2	8/2013	Ehrenfels et al.	8,893,949 B2	11/2014	Shelton, IV et al.
8,506,478 B2	8/2013	Mizuyoshi	8,899,479 B2	12/2014	Cappuzzo et al.
8,512,325 B2	8/2013	Mathonnet	8,905,977 B2	12/2014	Shelton et al.
8,512,365 B2	8/2013	Wiener et al.	8,912,746 B2	12/2014	Reid et al.
8,521,331 B2	8/2013	Itkowitz	8,914,098 B2	12/2014	Brennan et al.
8,523,043 B2	9/2013	Ullrich et al.	8,918,207 B2	12/2014	Frisco
8,546,996 B2	10/2013	Messerly et al.	8,920,414 B2	12/2014	Stone et al.
8,554,697 B2	10/2013	Claus et al.	8,920,433 B2	12/2014	Barrier et al.
8,560,047 B2	10/2013	Haider et al.	8,930,203 B2	1/2015	Kiaie et al.
8,561,870 B2	10/2013	Baxter, III et al.	8,930,214 B2	1/2015	Woolford
8,562,598 B2	10/2013	Falkenstein et al.	8,931,679 B2	1/2015	Kostrzewski
8,566,115 B2	10/2013	Moore	8,945,095 B2	2/2015	Blumenkranz et al.
8,571,598 B2	10/2013	Valavi	8,945,163 B2	2/2015	Voegele et al.
8,573,459 B2	11/2013	Smith et al.	8,955,732 B2	2/2015	Zemlok et al.
8,573,465 B2	11/2013	Shelton, IV	8,956,581 B2	2/2015	Rosenbaum et al.
8,590,762 B2	11/2013	Hess et al.	8,960,519 B2	2/2015	Whitman et al.
8,591,536 B2	11/2013	Robertson	8,960,520 B2	2/2015	McCuen
8,595,607 B2	11/2013	Nekoomaram et al.	8,962,062 B2	2/2015	Podhajsky et al.
8,596,513 B2	12/2013	Olson et al.	8,967,443 B2	3/2015	McCuen
8,596,515 B2	12/2013	Okoniewski	8,967,455 B2	3/2015	Zhou
8,608,044 B2	12/2013	Hueil et al.	8,968,276 B2	3/2015	Zemlok et al.
8,608,045 B2	12/2013	Smith et al.	8,968,309 B2	3/2015	Roy et al.
8,616,431 B2	12/2013	Timm et al.	8,968,337 B2	3/2015	Whitfield et al.
8,620,055 B2	12/2013	Barratt et al.	8,968,358 B2	3/2015	Reschke
8,620,473 B2	12/2013	Diolaiti et al.	8,974,429 B2	3/2015	Gordon et al.
8,623,027 B2	1/2014	Price et al.	8,979,890 B2	3/2015	Boudreaux
8,627,483 B2	1/2014	Rachlin et al.	8,986,302 B2	3/2015	Aldridge et al.
8,627,995 B2	1/2014	Smith et al.	8,989,903 B2	3/2015	Weir et al.
8,628,518 B2	1/2014	Blumenkranz et al.	8,991,678 B2	3/2015	Wellman et al.
8,628,545 B2	1/2014	Cabrera et al.	8,992,565 B2	3/2015	Brisson et al.
8,631,987 B2	1/2014	Shelton, IV et al.	8,998,797 B2	4/2015	Omori
8,632,525 B2	1/2014	Kerr et al.	9,002,518 B2	4/2015	Manzo et al.
8,636,190 B2	1/2014	Zemlok et al.	9,010,611 B2	4/2015	Ross et al.
8,652,086 B2	2/2014	Gerg et al.	9,011,366 B2	4/2015	Dean et al.
8,652,121 B2	2/2014	Quick et al.	9,011,427 B2	4/2015	Price et al.
8,652,128 B2	2/2014	Ward	9,016,539 B2	4/2015	Kostrzewski et al.
8,657,176 B2	2/2014	Shelton, IV et al.	9,017,326 B2	4/2015	DiNardo et al.
8,657,177 B2	2/2014	Scirica et al.	9,020,240 B2	4/2015	Pettersson et al.
8,663,220 B2	3/2014	Wiener et al.	9,023,071 B2	5/2015	Miller et al.
8,666,544 B2	3/2014	Moll et al.	9,027,431 B2	5/2015	Tang et al.
8,682,049 B2	3/2014	Zhao et al.	9,028,494 B2	5/2015	Shelton, IV et al.
8,682,489 B2	3/2014	Itkowitz et al.	9,035,568 B2	5/2015	Ganton et al.
8,685,056 B2	4/2014	Evans et al.	9,038,882 B2	5/2015	Racenet et al.
8,688,188 B2	4/2014	Heller et al.	9,043,027 B2	5/2015	Durant et al.
8,701,962 B2	4/2014	Kostrzewski	9,044,227 B2	6/2015	Shelton, IV et al.
8,719,061 B2	5/2014	Birchall	9,044,244 B2	6/2015	Ludwin et al.
8,720,766 B2	5/2014	Hess et al.	9,044,261 B2	6/2015	Houser
8,733,613 B2	5/2014	Huitema et al.	9,050,063 B2	6/2015	Roe et al.
8,740,840 B2	6/2014	Foley et al.	9,050,083 B2	6/2015	Yates et al.
8,740,866 B2	6/2014	Reasoner et al.	9,050,120 B2	6/2015	Swarup et al.
8,747,238 B2	6/2014	Shelton, IV et al.	9,052,809 B2	6/2015	Vesto
8,752,749 B2	6/2014	Moore et al.	9,055,035 B2	6/2015	Porsch et al.
8,757,465 B2	6/2014	Woodard, Jr. et al.	9,060,770 B2	6/2015	Shelton, IV et al.
8,761,717 B1	6/2014	Buchheit	9,060,775 B2	6/2015	Wiener et al.
8,763,879 B2	7/2014	Shelton, IV et al.	9,066,650 B2	6/2015	Sekiguchi
8,768,251 B2	7/2014	Claus et al.	9,072,523 B2	7/2015	Houser et al.
8,771,270 B2	7/2014	Burbank	9,072,535 B2	7/2015	Shelton, IV et al.
8,775,196 B2	7/2014	Simpson et al.	9,072,536 B2	7/2015	Shelton, IV et al.
8,779,648 B2	7/2014	Giordano et al.	9,078,653 B2	7/2015	Leimbach et al.
8,790,253 B2	7/2014	Sunagawa et al.	9,078,727 B2	7/2015	Miller
8,794,497 B2	8/2014	Zingman	9,084,606 B2	7/2015	Greep
8,799,008 B2	8/2014	Johnson et al.	9,089,360 B2	7/2015	Messerly et al.
8,799,009 B2	8/2014	Mellin et al.	9,095,362 B2	8/2015	Dachs, II et al.
8,800,838 B2	8/2014	Shelton, IV	9,095,367 B2	8/2015	Olson et al.
8,801,703 B2	8/2014	Gregg et al.	9,099,863 B2	8/2015	Smith et al.
8,814,996 B2	8/2014	Giurgutiu et al.	9,101,358 B2	8/2015	Kerr et al.
8,818,556 B2	8/2014	Sanchez et al.	9,101,359 B2	8/2015	Smith et al.
8,820,603 B2	9/2014	Shelton, IV et al.	9,101,374 B1	8/2015	Hoch et al.
			9,106,270 B2	8/2015	Puterbaugh et al.
			9,107,573 B2	8/2015	Birkrant
			9,107,662 B2	8/2015	Kostrzewski
			9,107,684 B2	8/2015	Ma

(56)

References Cited

U.S. PATENT DOCUMENTS

9,107,688	B2	8/2015	Kimball et al.	9,364,231	B2	6/2016	Wenchell
9,107,689	B2	8/2015	Robertson et al.	9,364,249	B2	6/2016	Kimball et al.
9,107,694	B2	8/2015	Hendriks et al.	9,364,294	B2	6/2016	Razzaque et al.
9,111,548	B2	8/2015	Nandy et al.	9,370,400	B2	6/2016	Parihar
9,113,880	B2	8/2015	Zemlok et al.	9,375,282	B2	6/2016	Nau, Jr. et al.
9,114,494	B1	8/2015	Mah	9,375,539	B2	6/2016	Stearns et al.
9,116,597	B1	8/2015	Gulasky	9,381,003	B2	7/2016	Todor et al.
9,119,617	B2	9/2015	Souls et al.	9,381,058	B2	7/2016	Houser et al.
9,119,655	B2	9/2015	Bowling et al.	9,386,984	B2	7/2016	Aronhalt et al.
9,119,657	B2	9/2015	Shelton, IV et al.	9,386,988	B2	7/2016	Baxter, III et al.
9,123,155	B2	9/2015	Cunningham et al.	9,387,295	B1	7/2016	Mastri et al.
9,125,644	B2	9/2015	Lane et al.	9,393,017	B2	7/2016	Flanagan et al.
9,129,054	B2	9/2015	Nawana et al.	9,393,037	B2	7/2016	Olson et al.
9,137,254	B2	9/2015	Billbrey et al.	9,398,905	B2	7/2016	Martin
9,138,129	B2	9/2015	Diolaiti	9,398,911	B2	7/2016	Auld
9,138,225	B2	9/2015	Huang et al.	9,402,629	B2	8/2016	Ehrenfels et al.
9,149,322	B2	10/2015	Knowlton	9,414,776	B2	8/2016	Sillay et al.
9,161,803	B2	10/2015	Yates et al.	9,419,018	B2	8/2016	Sasagawa et al.
9,168,054	B2	10/2015	Turner et al.	9,421,014	B2	8/2016	Ingmanson et al.
9,179,912	B2	11/2015	Yates et al.	9,433,470	B2	9/2016	Choi
9,183,723	B2	11/2015	Sherman et al.	9,439,622	B2	9/2016	Case et al.
9,186,143	B2	11/2015	Timm et al.	9,439,668	B2	9/2016	Timm et al.
9,192,375	B2	11/2015	Skinlo et al.	9,439,736	B2	9/2016	Olson
9,192,447	B2	11/2015	Choi et al.	9,445,764	B2	9/2016	Gross et al.
9,192,707	B2	11/2015	Gerber et al.	9,445,813	B2	9/2016	Shelton, IV et al.
9,202,078	B2	12/2015	Abuelsaad et al.	9,450,701	B2	9/2016	Do et al.
9,204,879	B2	12/2015	Shelton, IV	9,451,949	B2	9/2016	Gorek et al.
9,204,995	B2	12/2015	Scheller et al.	9,451,958	B2	9/2016	Shelton, IV et al.
9,216,062	B2	12/2015	Duque et al.	9,463,022	B2	10/2016	Swayze et al.
9,218,053	B2	12/2015	Komuro et al.	9,468,438	B2	10/2016	Baber et al.
9,226,689	B2	1/2016	Jacobsen et al.	9,480,492	B2	11/2016	Aranyi et al.
9,226,766	B2	1/2016	Aldridge et al.	9,485,475	B2	11/2016	Speier et al.
9,226,767	B2	1/2016	Stulen et al.	9,492,146	B2	11/2016	Kostrzewski et al.
9,232,883	B2	1/2016	Ozawa et al.	9,492,237	B2	11/2016	Kang et al.
9,237,891	B2	1/2016	Shelton, IV	9,498,215	B2	11/2016	Duque et al.
9,237,921	B2	1/2016	Messerly et al.	9,498,231	B2	11/2016	Haidler et al.
9,241,728	B2	1/2016	Price et al.	9,516,239	B2	12/2016	Blanquart et al.
9,241,731	B2	1/2016	Boudreaux et al.	9,519,753	B1	12/2016	Gerdeman et al.
9,247,996	B1	2/2016	Merana et al.	9,522,003	B2	12/2016	Weir et al.
9,250,172	B2	2/2016	Harris et al.	9,526,407	B2	12/2016	Hoeg et al.
9,255,907	B2	2/2016	Heanue et al.	9,526,499	B2	12/2016	Kostrzewski et al.
9,265,585	B2	2/2016	Wingardner et al.	9,526,587	B2	12/2016	Zhao et al.
9,272,406	B2	3/2016	Aronhalt et al.	9,539,007	B2	1/2017	Dhakad et al.
9,277,956	B2	3/2016	Zhang	9,539,020	B2	1/2017	Conlon et al.
9,280,884	B1	3/2016	Schultz et al.	9,542,481	B2	1/2017	Halter et al.
9,282,974	B2	3/2016	Shelton, IV	9,546,662	B2	1/2017	Shener-Irmakoglu et al.
9,283,054	B2	3/2016	Morgan et al.	9,554,794	B2	1/2017	Baber et al.
9,289,211	B2	3/2016	Williams et al.	9,554,854	B2	1/2017	Yates et al.
9,289,212	B2	3/2016	Shelton, IV et al.	9,561,038	B2	2/2017	Shelton, IV et al.
9,295,514	B2	3/2016	Shelton, IV et al.	9,561,045	B2	2/2017	Hinman et al.
9,301,691	B2	4/2016	Hufnagel et al.	9,566,708	B2	2/2017	Kurnianto
9,301,753	B2	4/2016	Aldridge et al.	9,572,592	B2	2/2017	Price et al.
9,301,759	B2	4/2016	Spivey et al.	9,579,503	B2	2/2017	McKinney et al.
9,301,810	B2	4/2016	Amiri et al.	9,585,657	B2	3/2017	Shelton, IV et al.
9,302,213	B2	4/2016	Manahan et al.	9,592,095	B2	3/2017	Panescu et al.
9,307,894	B2	4/2016	von Grunberg et al.	9,597,081	B2	3/2017	Swayze et al.
9,307,914	B2	4/2016	Fahey	9,600,138	B2	3/2017	Thomas et al.
9,307,986	B2	4/2016	Hall et al.	9,603,024	B2	3/2017	Wang et al.
9,314,246	B2	4/2016	Shelton, IV et al.	9,610,114	B2	4/2017	Baxter, III et al.
9,314,308	B2	4/2016	Parihar et al.	9,622,808	B2	4/2017	Beller et al.
9,325,732	B1	4/2016	Stickle et al.	9,628,501	B2	4/2017	Datta Ray et al.
9,326,767	B2	5/2016	Koch et al.	9,629,560	B2	4/2017	Joseph
9,331,422	B2	5/2016	Nazzaro et al.	9,629,623	B2	4/2017	Lytle, IV et al.
9,332,987	B2	5/2016	Leimbach et al.	9,629,628	B2	4/2017	Aranyi
9,333,042	B2	5/2016	Diolaiti et al.	9,629,629	B2	4/2017	Leimbach et al.
9,336,385	B1	5/2016	Spencer et al.	9,630,318	B2	4/2017	Ibarz Gabardos et al.
9,341,704	B2	5/2016	Picard et al.	9,636,188	B2	5/2017	Gattani et al.
9,345,481	B2	5/2016	Hall et al.	9,636,825	B2	5/2017	Penn et al.
9,345,490	B2	5/2016	Ippisch	9,641,596	B2	5/2017	Unagami et al.
9,345,546	B2	5/2016	Toth et al.	9,641,815	B2	5/2017	Richardson et al.
9,351,726	B2	5/2016	Leimbach et al.	9,642,620	B2	5/2017	Baxter, III et al.
9,351,727	B2	5/2016	Leimbach et al.	9,649,110	B2	5/2017	Parihar et al.
9,358,003	B2	6/2016	Hall et al.	9,649,111	B2	5/2017	Shelton, IV et al.
9,358,685	B2	6/2016	Meier et al.	9,649,126	B2	5/2017	Robertson et al.
9,360,449	B2	6/2016	Duric	9,649,169	B2	5/2017	Cinquin et al.
				9,652,655	B2	5/2017	Satish et al.
				9,655,616	B2	5/2017	Aranyi
				9,656,092	B2	5/2017	Golden
				9,662,116	B2	5/2017	Smith et al.

(56)

References Cited

U.S. PATENT DOCUMENTS

9,662,177 B2	5/2017	Weir et al.	9,820,738 B2	11/2017	Lytle, IV et al.
9,668,729 B2	6/2017	Williams et al.	9,820,741 B2	11/2017	Kostrzewski
9,668,732 B2	6/2017	Patel et al.	9,826,976 B2	11/2017	Parihar et al.
9,668,765 B2	6/2017	Grace et al.	9,826,977 B2	11/2017	Leimbach et al.
9,671,860 B2	6/2017	Ogawa et al.	9,827,054 B2	11/2017	Richmond et al.
9,675,264 B2	6/2017	Acquista et al.	9,827,059 B2	11/2017	Robinson et al.
9,675,354 B2	6/2017	Weir et al.	9,830,424 B2	11/2017	Dixon et al.
9,681,870 B2	6/2017	Baxter, III et al.	9,833,241 B2	12/2017	Huitema et al.
9,686,306 B2	6/2017	Chizeck et al.	9,839,419 B2	12/2017	Deck et al.
9,687,230 B2	6/2017	Leimbach et al.	9,839,424 B2	12/2017	Zergiebel et al.
9,690,362 B2	6/2017	Leimbach et al.	9,839,428 B2	12/2017	Baxter, III et al.
9,700,292 B2	7/2017	Nawana et al.	9,839,470 B2	12/2017	Gilbert et al.
9,700,309 B2	7/2017	Jaworek et al.	9,839,487 B2	12/2017	Dachs, II
9,700,312 B2	7/2017	Kostrzewski et al.	9,844,368 B2	12/2017	Boudreaux et al.
9,706,993 B2	7/2017	Hessler et al.	9,844,369 B2	12/2017	Huitema et al.
9,710,214 B2	7/2017	Lin et al.	9,844,374 B2	12/2017	Lytle, IV et al.
9,710,644 B2	7/2017	Reybok et al.	9,844,375 B2	12/2017	Overmyer et al.
9,713,424 B2	7/2017	Spaide	9,844,379 B2	12/2017	Shelton, IV et al.
9,717,141 B1	7/2017	Tegg	9,848,058 B2	12/2017	Johnson et al.
9,717,498 B2	8/2017	Aranyi et al.	9,848,877 B2	12/2017	Shelton, IV et al.
9,717,525 B2	8/2017	Ahluwalia et al.	9,861,354 B2	1/2018	Saliman et al.
9,717,548 B2	8/2017	Couture	9,861,363 B2	1/2018	Chen et al.
9,724,094 B2	8/2017	Baber et al.	9,861,428 B2	1/2018	Trees et al.
9,724,118 B2	8/2017	Schulte et al.	9,867,612 B2	1/2018	Parihar et al.
9,733,663 B2	8/2017	Leimbach et al.	9,867,651 B2	1/2018	Wham
9,737,301 B2	8/2017	Baber et al.	9,867,914 B2	1/2018	Bonano et al.
9,737,310 B2	8/2017	Whitfield et al.	9,872,609 B2	1/2018	Levy
9,737,335 B2	8/2017	Butler et al.	9,872,683 B2	1/2018	Hopkins et al.
9,737,355 B2	8/2017	Yates et al.	9,877,718 B2	1/2018	Weir et al.
9,740,826 B2	8/2017	Raghavan et al.	9,877,721 B2	1/2018	Schellin et al.
9,743,016 B2	8/2017	Nestares et al.	9,883,860 B2	2/2018	Leimbach
9,743,929 B2	8/2017	Leimbach et al.	9,888,914 B2	2/2018	Martin et al.
9,743,946 B2	8/2017	Faller et al.	9,888,919 B2	2/2018	Leimbach et al.
9,743,947 B2	8/2017	Price et al.	9,888,921 B2	2/2018	Williams et al.
9,750,499 B2	9/2017	Leimbach et al.	9,888,975 B2	2/2018	Auld
9,750,500 B2	9/2017	Malkowski	9,895,148 B2	2/2018	Shelton, IV et al.
9,750,522 B2	9/2017	Scheib et al.	9,900,787 B2	2/2018	Ou
9,750,523 B2	9/2017	Tsubuku	9,901,342 B2	2/2018	Shelton, IV et al.
9,753,135 B2	9/2017	Bosch	9,901,406 B2	2/2018	State et al.
9,753,568 B2	9/2017	McMillen	9,905,000 B2	2/2018	Chou et al.
9,757,126 B2	9/2017	Cappola	9,907,550 B2	3/2018	Sniffin et al.
9,757,128 B2	9/2017	Baber et al.	9,913,642 B2	3/2018	Leimbach et al.
9,757,142 B2	9/2017	Shimizu	9,913,645 B2	3/2018	Zerkle et al.
9,757,152 B2	9/2017	Ogilvie et al.	9,918,730 B2	3/2018	Trees et al.
9,763,741 B2	9/2017	Alvarez et al.	9,918,778 B2	3/2018	Walberg et al.
9,764,164 B2	9/2017	Wiener et al.	9,918,788 B2	3/2018	Paul et al.
9,770,541 B2	9/2017	Carr et al.	9,922,304 B2	3/2018	DeBusk et al.
9,777,913 B2	10/2017	Talbert et al.	9,924,941 B2	3/2018	Burbank
9,782,164 B2	10/2017	Mumaw et al.	9,924,944 B2	3/2018	Shelton, IV et al.
9,782,169 B2	10/2017	Kimsey et al.	9,924,961 B2	3/2018	Shelton, IV et al.
9,782,212 B2	10/2017	Wham et al.	9,931,040 B2	4/2018	Homyk et al.
9,782,214 B2	10/2017	Houser et al.	9,931,118 B2	4/2018	Shelton, IV et al.
9,788,836 B2	10/2017	Overmyer et al.	9,931,124 B2	4/2018	Gokharu
9,788,851 B2	10/2017	Dannaher et al.	9,936,942 B2	4/2018	Chin et al.
9,788,902 B2	10/2017	Inoue et al.	9,936,955 B2	4/2018	Miller et al.
9,788,907 B1	10/2017	Alvi et al.	9,936,961 B2	4/2018	Chien et al.
9,795,436 B2	10/2017	Yates et al.	9,937,012 B2	4/2018	Hares et al.
9,797,486 B2	10/2017	Zergiebel et al.	9,937,014 B2	4/2018	Bowling et al.
9,801,531 B2	10/2017	Morita et al.	9,937,626 B2	4/2018	Rockrohr
9,801,626 B2	10/2017	Parihar et al.	9,938,972 B2	4/2018	Walley
9,801,627 B2	10/2017	Harris et al.	9,943,230 B2	4/2018	Kaku et al.
9,801,679 B2	10/2017	Trees et al.	9,943,309 B2	4/2018	Shelton, IV et al.
9,802,033 B2	10/2017	Hibner et al.	9,943,312 B2	4/2018	Posada et al.
9,804,618 B2	10/2017	Leimbach et al.	9,943,377 B2	4/2018	Yates et al.
9,805,472 B2	10/2017	Chou et al.	9,943,379 B2	4/2018	Gregg, II et al.
9,808,244 B2	11/2017	Leimbach et al.	9,943,918 B2	4/2018	Grogan et al.
9,808,245 B2	11/2017	Richard et al.	9,949,785 B2	4/2018	Price et al.
9,808,246 B2	11/2017	Shelton, IV et al.	9,962,157 B2	5/2018	Sapre
9,808,248 B2	11/2017	Hoffman	9,968,355 B2	5/2018	Shelton, IV et al.
9,808,249 B2	11/2017	Shelton, IV	9,980,769 B2	5/2018	Trees et al.
9,814,457 B2	11/2017	Martin et al.	9,980,778 B2	5/2018	Ohline et al.
9,814,460 B2	11/2017	Kimsey et al.	9,987,000 B2	6/2018	Shelton, IV et al.
9,814,462 B2	11/2017	Woodard, Jr. et al.	9,990,856 B2	6/2018	Kuchenbecker et al.
9,814,463 B2	11/2017	Williams et al.	9,993,248 B2	6/2018	Shelton, IV et al.
9,820,699 B2	11/2017	Bingley et al.	9,993,258 B2	6/2018	Shelton, IV et al.
			9,993,305 B2	6/2018	Andersson
			10,004,491 B2	6/2018	Martin et al.
			10,004,497 B2	6/2018	Overmyer et al.
			10,004,500 B2	6/2018	Shelton, IV et al.

(56)

References Cited

U.S. PATENT DOCUMENTS

10,004,501 B2	6/2018	Shelton, IV et al.	10,179,413 B2	1/2019	Rockrohr
10,004,527 B2	6/2018	Gee et al.	10,180,463 B2	1/2019	Beckman et al.
10,004,557 B2	6/2018	Gross	10,182,814 B2	1/2019	Okoniewski
D822,206 S	7/2018	Shelton, IV et al.	10,182,816 B2	1/2019	Shelton, IV et al.
10,010,322 B2	7/2018	Shelton, IV et al.	10,182,818 B2	1/2019	Hensel et al.
10,010,324 B2	7/2018	Huitema et al.	10,188,385 B2	1/2019	Kerr et al.
10,013,049 B2	7/2018	Leimbach et al.	10,189,157 B2	1/2019	Schlegel et al.
10,016,199 B2	7/2018	Baber et al.	10,194,907 B2	2/2019	Marczyk et al.
10,021,318 B2	7/2018	Hugosson et al.	10,194,913 B2	2/2019	Nalagatla et al.
10,022,120 B2	7/2018	Martin et al.	10,197,803 B2	2/2019	Badiali et al.
10,022,391 B2	7/2018	Ruderman Chen et al.	10,198,965 B2	2/2019	Hart
10,022,568 B2	7/2018	Messerly et al.	10,201,311 B2	2/2019	Chou et al.
10,028,744 B2	7/2018	Shelton, IV et al.	10,201,349 B2	2/2019	Leimbach et al.
10,028,761 B2	7/2018	Leimbach et al.	10,201,364 B2	2/2019	Leimbach et al.
10,028,788 B2	7/2018	Kang	10,201,365 B2	2/2019	Boudreaux et al.
10,034,704 B2	7/2018	Asher et al.	10,205,708 B1	2/2019	Fletcher et al.
10,037,641 B2	7/2018	Hyde et al.	10,206,605 B2	2/2019	Shelton, IV et al.
D826,405 S	8/2018	Shelton, IV et al.	10,206,752 B2	2/2019	Hares et al.
10,039,564 B2	8/2018	Hibner et al.	10,213,201 B2	2/2019	Shelton, IV et al.
10,039,565 B2	8/2018	Vezzu	10,213,203 B2	2/2019	Swayze et al.
10,041,822 B2	8/2018	Zemlok	10,213,266 B2	2/2019	Zemlok et al.
10,044,791 B2	8/2018	Kamen et al.	10,213,268 B2	2/2019	Dachs, II
10,045,776 B2	8/2018	Shelton, IV et al.	10,219,491 B2	3/2019	Stiles, Jr. et al.
10,045,779 B2	8/2018	Savage et al.	10,220,522 B2	3/2019	Rockrohr
10,045,781 B2	8/2018	Cropper et al.	10,222,750 B2	3/2019	Bang et al.
10,045,813 B2	8/2018	Mueller	10,226,249 B2	3/2019	Jaworek et al.
10,048,379 B2	8/2018	Markendorf et al.	10,226,250 B2	3/2019	Beckman et al.
10,052,044 B2	8/2018	Shelton, IV et al.	10,226,302 B2	3/2019	Lacal et al.
10,052,102 B2	8/2018	Baxter, III et al.	10,231,634 B2	3/2019	Zand et al.
10,052,104 B2	8/2018	Shelton, IV et al.	10,231,733 B2	3/2019	Ehrenfels et al.
10,054,441 B2	8/2018	Schorr et al.	10,231,775 B2	3/2019	Shelton, IV et al.
10,069,633 B2	9/2018	Gulati et al.	10,238,413 B2	3/2019	Hibner et al.
10,076,326 B2	9/2018	Yates et al.	10,245,027 B2	4/2019	Shelton, IV et al.
10,080,618 B2	9/2018	Marshall et al.	10,245,028 B2	4/2019	Shelton, IV et al.
D831,209 S	10/2018	Huitema et al.	10,245,029 B2	4/2019	Hunter et al.
10,085,748 B2	10/2018	Morgan et al.	10,245,030 B2	4/2019	Hunter et al.
10,085,749 B2	10/2018	Cappola et al.	10,245,033 B2	4/2019	Overmyer et al.
10,095,942 B2	10/2018	Mentese et al.	10,245,037 B2	4/2019	Conklin et al.
10,097,578 B2	10/2018	Baldonado et al.	10,245,038 B2	4/2019	Hopkins et al.
10,098,527 B2	10/2018	Weisenburgh, II et al.	10,251,661 B2	4/2019	Collings et al.
10,098,635 B2	10/2018	Burbank	10,251,725 B2	4/2019	Valentine et al.
10,098,642 B2	10/2018	Baxter, III et al.	10,258,331 B2	4/2019	Shelton, IV et al.
10,098,705 B2	10/2018	Brisson et al.	10,258,359 B2	4/2019	Kapadia
10,105,140 B2	10/2018	Malinouskas et al.	10,258,362 B2	4/2019	Conlon
10,105,142 B2	10/2018	Baxter, III et al.	10,258,363 B2	4/2019	Worrell et al.
10,111,658 B2	10/2018	Chowaniec et al.	10,258,415 B2	4/2019	Harrah et al.
10,111,665 B2	10/2018	Aranyi et al.	10,258,418 B2	4/2019	Shelton, IV et al.
10,111,679 B2	10/2018	Baber et al.	10,258,425 B2	4/2019	Mustufa et al.
10,117,649 B2	11/2018	Baxter et al.	10,263,171 B2	4/2019	Wiener et al.
10,117,651 B2	11/2018	Whitman et al.	10,265,035 B2	4/2019	Fehre et al.
10,117,702 B2	11/2018	Danziger et al.	10,265,068 B2	4/2019	Harris et al.
10,118,119 B2	11/2018	Sappok et al.	10,265,072 B2	4/2019	Shelton, IV et al.
10,130,359 B2	11/2018	Hess et al.	10,265,090 B2	4/2019	Ingmanson et al.
10,130,360 B2	11/2018	Olson et al.	10,265,130 B2	4/2019	Hess et al.
10,130,361 B2	11/2018	Yates et al.	10,271,840 B2	4/2019	Sapre
10,130,367 B2	11/2018	Cappola et al.	10,271,844 B2	4/2019	Valentine et al.
10,133,248 B2	11/2018	Fitzsimmons et al.	10,271,850 B2	4/2019	Williams
10,135,242 B2	11/2018	Baber et al.	10,271,851 B2	4/2019	Shelton, IV et al.
10,136,887 B2	11/2018	Shelton, IV et al.	D847,989 S	5/2019	Shelton, IV et al.
10,136,949 B2	11/2018	Felder et al.	10,278,698 B2	5/2019	Racenet
10,143,526 B2	12/2018	Walker et al.	10,278,778 B2	5/2019	State et al.
10,143,948 B2	12/2018	Bonifas et al.	10,283,220 B2	5/2019	Azizian et al.
10,149,680 B2	12/2018	Parihar et al.	10,285,694 B2	5/2019	Viola et al.
10,152,789 B2	12/2018	Carnes et al.	10,285,698 B2	5/2019	Cappola et al.
10,154,841 B2	12/2018	Weaner et al.	10,285,700 B2	5/2019	Scheib
10,159,044 B2	12/2018	Hrabak	10,285,705 B2	5/2019	Shelton, IV et al.
10,159,481 B2	12/2018	Whitman et al.	10,292,704 B2	5/2019	Harris et al.
10,159,483 B2	12/2018	Beckman et al.	10,292,707 B2	5/2019	Shelton, IV et al.
10,164,466 B2	12/2018	Calderoni	10,292,758 B2	5/2019	Boudreaux et al.
10,166,025 B2	1/2019	Leimbach et al.	10,292,771 B2	5/2019	Wood et al.
10,169,862 B2	1/2019	Andre et al.	10,299,792 B2	5/2019	Huitema et al.
10,172,687 B2	1/2019	Garbus et al.	10,299,870 B2	5/2019	Connolly et al.
10,175,096 B2	1/2019	Dickerson	10,305,926 B2	5/2019	Mihan et al.
10,175,127 B2	1/2019	Collins et al.	D850,617 S	6/2019	Shelton, IV et al.
10,178,992 B2	1/2019	Wise et al.	10,307,159 B2	6/2019	Harris et al.
			10,307,170 B2	6/2019	Parfett et al.
			10,307,199 B2	6/2019	Farritor et al.
			10,311,036 B1	6/2019	Hussam et al.
			10,313,137 B2	6/2019	Aarnio et al.

(56)

References Cited

U.S. PATENT DOCUMENTS

10,314,577 B2	6/2019	Laurent et al.	10,470,791 B2	11/2019	Houser
10,314,582 B2	6/2019	Shelton, IV et al.	10,471,254 B2	11/2019	Sano et al.
10,321,907 B2	6/2019	Shelton, IV et al.	10,478,181 B2	11/2019	Shelton, IV et al.
10,321,964 B2	6/2019	Grover et al.	10,478,189 B2	11/2019	Bear et al.
10,327,764 B2	6/2019	Harris et al.	10,478,190 B2	11/2019	Miller et al.
10,335,147 B2	7/2019	Rector et al.	10,478,544 B2	11/2019	Friederichs et al.
10,335,149 B2	7/2019	Baxter, III et al.	10,485,450 B2	11/2019	Gupta et al.
10,335,180 B2	7/2019	Johnson et al.	10,485,542 B2	11/2019	Shelton, IV et al.
10,335,227 B2	7/2019	Heard	10,485,543 B2	11/2019	Shelton, IV et al.
10,342,543 B2	7/2019	Shelton, IV et al.	10,492,783 B2	12/2019	Shelton, IV et al.
10,342,602 B2	7/2019	Strobl et al.	10,492,785 B2	12/2019	Overmyer et al.
10,342,623 B2	7/2019	Huelman et al.	10,496,788 B2	12/2019	Amarasingham et al.
10,343,102 B2	7/2019	Reasoner et al.	10,498,269 B2	12/2019	Zemlok et al.
10,357,246 B2	7/2019	Shelton, IV et al.	10,499,891 B2	12/2019	Chaplin et al.
10,357,247 B2	7/2019	Shelton, IV et al.	10,499,914 B2	12/2019	Huang et al.
10,362,179 B2	7/2019	Harris	10,499,915 B2	12/2019	Aranyi
10,363,032 B2	7/2019	Scheib et al.	10,499,994 B2	12/2019	Luks et al.
10,363,037 B2	7/2019	Aronhalt et al.	10,507,068 B2	12/2019	Kopp et al.
10,368,861 B2	8/2019	Baxter, III et al.	10,512,461 B2	12/2019	Gupta et al.
10,368,865 B2	8/2019	Harris et al.	10,512,499 B2	12/2019	McHenry et al.
10,368,867 B2	8/2019	Harris et al.	10,512,514 B2	12/2019	Nowlin et al.
10,368,876 B2	8/2019	Bhatnagar et al.	10,517,588 B2	12/2019	Gupta et al.
10,368,894 B2	8/2019	Madan et al.	10,517,595 B2	12/2019	Hunter et al.
10,368,903 B2	8/2019	Morales et al.	10,517,596 B2	12/2019	Hunter et al.
10,376,263 B2	8/2019	Morgan et al.	10,517,686 B2	12/2019	Vokrot et al.
10,376,305 B2	8/2019	Yates et al.	10,524,789 B2	1/2020	Swayze et al.
10,376,337 B2	8/2019	Kilroy et al.	10,531,874 B2	1/2020	Morgan et al.
10,376,338 B2	8/2019	Taylor et al.	10,531,929 B2	1/2020	Widenhouse et al.
10,378,893 B2	8/2019	Mankovskii	10,532,330 B2	1/2020	Diallo et al.
10,383,518 B2	8/2019	Abu-Tarif et al.	10,536,617 B2	1/2020	Liang et al.
10,383,699 B2	8/2019	Kilroy et al.	10,537,324 B2	1/2020	Shelton, IV et al.
10,390,718 B2	8/2019	Chen et al.	10,537,325 B2	1/2020	Bakos et al.
10,390,794 B2	8/2019	Kuroiwa et al.	10,537,351 B2	1/2020	Shelton, IV et al.
10,390,825 B2	8/2019	Shelton, IV et al.	10,542,978 B2	1/2020	Chowaniec et al.
10,390,831 B2	8/2019	Holsten et al.	10,542,979 B2	1/2020	Shelton, IV et al.
10,390,895 B2	8/2019	Henderson et al.	10,542,982 B2	1/2020	Beckman et al.
10,398,434 B2	9/2019	Shelton, IV et al.	10,542,991 B2	1/2020	Shelton, IV et al.
10,398,517 B2	9/2019	Eckert et al.	10,548,504 B2	2/2020	Shelton, IV et al.
10,398,521 B2	9/2019	Itkowitz et al.	10,548,612 B2	2/2020	Martinez et al.
10,404,521 B2	9/2019	McChord et al.	10,548,673 B2	2/2020	Harris et al.
10,404,801 B2	9/2019	March	10,552,574 B2	2/2020	Sweeney
10,405,857 B2	9/2019	Shelton, IV et al.	10,555,675 B2	2/2020	Satish et al.
10,405,863 B2	9/2019	Wise et al.	10,555,748 B2	2/2020	Yates et al.
10,413,291 B2	9/2019	Worthington et al.	10,555,750 B2	2/2020	Conlon et al.
10,413,293 B2	9/2019	Shelton, IV et al.	10,555,769 B2	2/2020	Worrell et al.
10,413,297 B2	9/2019	Harris et al.	10,561,422 B2	2/2020	Schellin et al.
10,417,446 B2	9/2019	Takeyama	10,561,471 B2	2/2020	Nichogi
10,420,552 B2	9/2019	Shelton, IV et al.	10,568,625 B2	2/2020	Harris et al.
10,420,558 B2	9/2019	Nalagatla et al.	10,568,626 B2	2/2020	Shelton, IV et al.
10,420,559 B2	9/2019	Marczyk et al.	10,568,632 B2	2/2020	Miller et al.
10,420,620 B2	9/2019	Rockrohr	10,568,704 B2	2/2020	Savall et al.
10,420,865 B2	9/2019	Reasoner et al.	10,575,868 B2	3/2020	Hall et al.
10,422,727 B2	9/2019	Pliskin	10,582,928 B2	3/2020	Hunter et al.
10,426,466 B2	10/2019	Contini et al.	10,582,931 B2	3/2020	Mujawar
10,426,467 B2	10/2019	Miller et al.	10,586,074 B2	3/2020	Rose et al.
10,426,468 B2	10/2019	Contini et al.	10,588,625 B2	3/2020	Weaner et al.
10,426,471 B2	10/2019	Shelton, IV et al.	10,588,629 B2	3/2020	Malinouskas et al.
10,433,837 B2	10/2019	Worthington et al.	10,588,630 B2	3/2020	Shelton, IV et al.
10,433,844 B2	10/2019	Shelton, IV et al.	10,588,631 B2	3/2020	Shelton, IV et al.
10,433,849 B2	10/2019	Shelton, IV et al.	10,588,632 B2	3/2020	Shelton, IV et al.
10,433,918 B2	10/2019	Shelton, IV et al.	10,588,711 B2	3/2020	DiCarlo et al.
10,441,279 B2	10/2019	Shelton, IV et al.	10,592,067 B2	3/2020	Merdan et al.
10,441,345 B2	10/2019	Aldridge et al.	10,595,882 B2	3/2020	Parfett et al.
10,448,948 B2	10/2019	Shelton, IV et al.	10,595,887 B2	3/2020	Shelton, IV et al.
10,448,950 B2	10/2019	Shelton, IV et al.	10,595,930 B2	3/2020	Scheib et al.
10,456,137 B2	10/2019	Vendely et al.	10,595,952 B2	3/2020	Forrest et al.
10,456,140 B2	10/2019	Shelton, IV et al.	10,602,848 B2	3/2020	Magana
10,456,193 B2	10/2019	Yates et al.	10,603,036 B2	3/2020	Hunter et al.
10,463,365 B2	11/2019	Williams	10,603,128 B2	3/2020	Zergiebel et al.
10,463,367 B2	11/2019	Kostrzewski et al.	10,610,223 B2	4/2020	Wellman et al.
10,463,371 B2	11/2019	Kostrzewski	10,610,224 B2	4/2020	Shelton, IV et al.
10,463,436 B2	11/2019	Jackson et al.	10,610,286 B2	4/2020	Wiener et al.
10,470,762 B2	11/2019	Leimbach et al.	10,610,313 B2	4/2020	Bailey et al.
10,470,764 B2	11/2019	Baxter, III et al.	10,617,412 B2	4/2020	Shelton, IV et al.
10,470,768 B2	11/2019	Harris et al.	10,617,414 B2	4/2020	Shelton, IV et al.
			10,617,482 B2	4/2020	Houser et al.
			10,617,484 B2	4/2020	Kilroy et al.
			10,624,635 B2	4/2020	Harris et al.
			10,624,691 B2	4/2020	Wiener et al.

(56)

References Cited

U.S. PATENT DOCUMENTS

10,631,423	B2	4/2020	Collins et al.	2007/0249990	A1	10/2007	Cosmescu
10,631,912	B2	4/2020	McFarlin et al.	2007/0270660	A1	11/2007	Caylor et al.
10,631,916	B2	4/2020	Horner et al.	2007/0293218	A1	12/2007	Meylan et al.
10,631,917	B2	4/2020	Ineson	2008/0013460	A1	1/2008	Allen et al.
10,631,939	B2	4/2020	Dachs, II et al.	2008/0015664	A1	1/2008	Podhajsky
10,639,027	B2	5/2020	Shelton, IV et al.	2008/0015912	A1	1/2008	Rosenthal et al.
10,639,034	B2	5/2020	Harris et al.	2008/0033404	A1	2/2008	Romoda et al.
10,639,035	B2	5/2020	Shelton, IV et al.	2008/0040151	A1	2/2008	Moore
10,639,036	B2	5/2020	Yates et al.	2008/0059658	A1	3/2008	Williams
10,639,037	B2	5/2020	Shelton, IV et al.	2008/0077158	A1	3/2008	Haider et al.
10,639,039	B2	5/2020	Vendely et al.	2008/0083414	A1	4/2008	Messerges
10,639,098	B2	5/2020	Cosman et al.	2008/0177362	A1	7/2008	Phillips et al.
10,639,111	B2	5/2020	Kopp	2008/0255413	A1	10/2008	Zemlok et al.
10,639,185	B2	5/2020	Agrawal et al.	2008/0262654	A1	10/2008	Omori et al.
10,653,413	B2	5/2020	Worthington et al.	2008/0281301	A1	11/2008	DeBoer et al.
10,653,476	B2	5/2020	Ross	2008/0281678	A1	11/2008	Keuls et al.
10,653,489	B2	5/2020	Kopp	2008/0296346	A1	12/2008	Shelton, IV et al.
10,656,720	B1	5/2020	Holz	2009/0036750	A1	2/2009	Weinstein et al.
10,660,705	B2	5/2020	Piron et al.	2009/0036794	A1	2/2009	Stubhaug et al.
10,667,809	B2	6/2020	Bakos et al.	2009/0043253	A1	2/2009	Podaima
10,667,810	B2	6/2020	Shelton, IV et al.	2009/0046146	A1	2/2009	Hoyt
10,667,811	B2	6/2020	Harris et al.	2009/0048589	A1	2/2009	Takashino et al.
10,667,877	B2	6/2020	Kapadia	2009/0076409	A1	3/2009	Wu et al.
10,674,897	B2	6/2020	Levy	2009/0090763	A1	4/2009	Zemlok et al.
10,675,035	B2	6/2020	Zingman	2009/0099866	A1	4/2009	Newman
10,695,134	B2	6/2020	Barral et al.	2009/0182577	A1	7/2009	Squilla et al.
D893,717	S	8/2020	Messerly et al.	2009/0206131	A1	8/2009	Weisenburgh, II et al.
10,729,458	B2	8/2020	Stoddard et al.	2009/0217932	A1	9/2009	Voegele
10,751,052	B2	8/2020	Stokes et al.	2009/0234352	A1	9/2009	Behnke et al.
D896,379	S	9/2020	Shelton, IV et al.	2009/0259149	A1	10/2009	Tahara et al.
10,786,317	B2	9/2020	Zhou et al.	2009/0259221	A1	10/2009	Tahara et al.
10,786,327	B2	9/2020	Anderson et al.	2009/0307681	A1	12/2009	Armado et al.
10,792,118	B2	10/2020	Prpa et al.	2009/0326321	A1	12/2009	Jacobsen et al.
10,842,897	B2	11/2020	Schwartz et al.	2009/0326336	A1	12/2009	Lemke et al.
10,864,050	B2	12/2020	Tabandeh et al.	2010/0065604	A1	3/2010	Weng
10,881,446	B2	1/2021	Strobl	2010/0069942	A1	3/2010	Shelton, IV
10,905,418	B2	2/2021	Shelton, IV et al.	2010/0070417	A1	3/2010	Flynn et al.
10,905,420	B2	2/2021	Jasemian et al.	2010/0132334	A1	6/2010	Duclos et al.
2002/0049551	A1	4/2002	Friedman et al.	2010/0137845	A1	6/2010	Ramstein et al.
2003/0093503	A1	5/2003	Yamaki et al.	2010/0179831	A1	7/2010	Brown et al.
2003/0114851	A1	6/2003	Truckai et al.	2010/0191100	A1	7/2010	Anderson et al.
2003/0210812	A1	11/2003	Khamene et al.	2010/0198248	A1	8/2010	Vakharia
2003/0223877	A1	12/2003	Anstine et al.	2010/0217991	A1	8/2010	Choi
2004/0078236	A1	4/2004	Stoodley et al.	2010/0235689	A1	9/2010	Tian et al.
2004/0199180	A1	10/2004	Knodel et al.	2010/0250571	A1	9/2010	Pierce et al.
2004/0199659	A1	10/2004	Ishikawa et al.	2010/0292535	A1	11/2010	Paskar
2004/0206365	A1	10/2004	Knowlton	2011/0022032	A1	1/2011	Zemlok et al.
2004/0243148	A1	12/2004	Wasielewski	2011/0077512	A1	3/2011	Boswell
2004/0243435	A1	12/2004	Williams	2011/0087238	A1	4/2011	Wang et al.
2005/0020909	A1	1/2005	Moctezuma De La Barrera et al.	2011/0105895	A1	5/2011	Kornblau et al.
2005/0063575	A1	3/2005	Ma et al.	2011/0118708	A1	5/2011	Burbank et al.
2005/0065438	A1	3/2005	Miller	2011/0118708	A1	5/2011	Burbank et al.
2005/0131390	A1	6/2005	Heinrich et al.	2011/0119075	A1	5/2011	Dhoble
2005/0143759	A1	6/2005	Kelly	2011/0125149	A1	5/2011	El-Galley et al.
2005/0149001	A1	7/2005	Uchikubo et al.	2011/0237883	A1	9/2011	Chun
2005/0149356	A1	7/2005	Cyr et al.	2011/0306840	A1	12/2011	Allen et al.
2005/0192633	A1	9/2005	Montpetit	2012/0022519	A1	1/2012	Huang et al.
2005/0222631	A1	10/2005	Dalal et al.	2012/0059684	A1	3/2012	Hampapur et al.
2005/0236474	A1	10/2005	Onuma et al.	2012/0116381	A1	5/2012	Houser et al.
2005/0277913	A1	12/2005	McCary	2012/0130217	A1	5/2012	Kauphusman et al.
2006/0020272	A1	1/2006	Gildenberg	2012/0172696	A1	7/2012	Kallback et al.
2006/0059018	A1	3/2006	Shiobara et al.	2012/0191091	A1	7/2012	Allen
2006/0116908	A1	6/2006	Dew et al.	2012/0203785	A1	8/2012	Awada
2006/0241399	A1	10/2006	Fabian	2012/0211542	A1	8/2012	Racenet
2007/0010838	A1	1/2007	Shelton et al.	2012/0245958	A1	9/2012	Lawrence et al.
2007/0016235	A1	1/2007	Tanaka et al.	2012/0265555	A1	10/2012	Cappuzzo et al.
2007/0027459	A1	2/2007	Horvath et al.	2012/0292367	A1	11/2012	Morgan et al.
2007/0049947	A1	3/2007	Menn et al.	2012/0319859	A1	12/2012	Taub et al.
2007/0078678	A1	4/2007	DiSilvestro et al.	2013/0024213	A1	1/2013	Poon
2007/0167702	A1	7/2007	Hasser et al.	2013/0046182	A1	2/2013	Hegg et al.
2007/0168461	A1	7/2007	Moore	2013/0046279	A1	2/2013	Niklewski et al.
2007/0173803	A1	7/2007	Wham et al.	2013/0066647	A1	3/2013	Andrie et al.
2007/0175955	A1	8/2007	Shelton et al.	2013/0090526	A1	4/2013	Suzuki et al.
2007/0225556	A1	9/2007	Ortiz et al.	2013/0093829	A1	4/2013	Rosenblatt et al.
2007/0244478	A1	10/2007	Bahney	2013/0105552	A1	5/2013	Weir et al.
				2013/0116218	A1	5/2013	Kaplan et al.
				2013/0165776	A1	6/2013	Blomqvist
				2013/0178853	A1	7/2013	Hyink et al.
				2013/0206813	A1	8/2013	Nalagatla
				2013/0214025	A1	8/2013	Zemlok et al.

(56)

References Cited

U.S. PATENT DOCUMENTS

2013/0253480	A1	9/2013	Kimball et al.	2016/0192960	A1	7/2016	Bueno et al.
2013/0256373	A1	10/2013	Schmid et al.	2016/0199125	A1	7/2016	Jones
2013/0277410	A1	10/2013	Fernandez et al.	2016/0206202	A1	7/2016	Frangioni
2013/0317837	A1	11/2013	Ballantyne et al.	2016/0235303	A1	8/2016	Fleming et al.
2013/0321425	A1	12/2013	Greene et al.	2016/0249910	A1	9/2016	Shelton, IV et al.
2013/0325809	A1	12/2013	Kim et al.	2016/0253472	A1	9/2016	Pedersen et al.
2013/0331874	A1	12/2013	Ross et al.	2016/0256154	A1	9/2016	Shelton, IV et al.
2013/0331875	A1	12/2013	Ross et al.	2016/0287912	A1	10/2016	Warnking
2014/0001231	A1	1/2014	Shelton, IV et al.	2016/0296246	A1	10/2016	Schaller
2014/0001234	A1	1/2014	Shelton, IV et al.	2016/0302210	A1	10/2016	Thornton et al.
2014/0005640	A1	1/2014	Shelton, IV et al.	2016/0310055	A1	10/2016	Zand et al.
2014/0006132	A1	1/2014	Barker	2016/0310203	A1	10/2016	Gaspredes et al.
2014/0006943	A1	1/2014	Robbins et al.	2016/0321400	A1	11/2016	Durrant et al.
2014/0029411	A1	1/2014	Nayak et al.	2016/0323283	A1	11/2016	Kang et al.
2014/0035762	A1	2/2014	Shelton, IV et al.	2016/0324537	A1	11/2016	Green et al.
2014/0066700	A1	3/2014	Wilson et al.	2016/0342916	A1	11/2016	Arceneaux et al.
2014/0081255	A1	3/2014	Johnson et al.	2016/0345857	A1	12/2016	Jensrud et al.
2014/0081659	A1	3/2014	Nawana et al.	2016/0345976	A1	12/2016	Gonzalez et al.
2014/0087999	A1	3/2014	Kaplan et al.	2016/0350490	A1	12/2016	Martinez et al.
2014/0092089	A1	4/2014	Kasuya et al.	2016/0361070	A1	12/2016	Ardel et al.
2014/0107697	A1	4/2014	Patani et al.	2016/0374665	A1	12/2016	DiNardo et al.
2014/0108035	A1	4/2014	Akbay et al.	2016/0374723	A1	12/2016	Frankhouser et al.
2014/0108983	A1	4/2014	William et al.	2016/0374762	A1	12/2016	Case et al.
2014/0148729	A1	5/2014	Schmitz et al.	2017/0000516	A1	1/2017	Stulen et al.
2014/0166724	A1	6/2014	Schellin et al.	2017/0000553	A1	1/2017	Wiener et al.
2014/0171923	A1	6/2014	Aranyi	2017/0000554	A1	1/2017	Yates et al.
2014/0187856	A1	7/2014	Holoien et al.	2017/0020462	A1	1/2017	Brown, III et al.
2014/0204190	A1	7/2014	Rosenblatt, III et al.	2017/0027603	A1	2/2017	Pandey
2014/0243799	A1	8/2014	Parihar	2017/0035514	A1	2/2017	Fox et al.
2014/0243809	A1	8/2014	Gelfand et al.	2017/0056116	A1	3/2017	Kostrzewski
2014/0246475	A1	9/2014	Hall et al.	2017/0061375	A1	3/2017	Laster et al.
2014/0249557	A1	9/2014	Koch et al.	2017/0068792	A1	3/2017	Reiner
2014/0252064	A1	9/2014	Mozdzierz et al.	2017/0079730	A1	3/2017	Azizian et al.
2014/0263541	A1	9/2014	Leimbach et al.	2017/0086829	A1	3/2017	Vendely et al.
2014/0263552	A1	9/2014	Hall et al.	2017/0086911	A1	3/2017	Wiener et al.
2014/0303660	A1	10/2014	Boyden et al.	2017/0086930	A1	3/2017	Thompson et al.
2015/0006201	A1	1/2015	Paït et al.	2017/0105754	A1	4/2017	Boudreaux et al.
2015/0025549	A1	1/2015	Kilroy et al.	2017/0116873	A1	4/2017	Lendvay et al.
2015/0032150	A1	1/2015	Ishida et al.	2017/0132374	A1	5/2017	Lee et al.
2015/0051617	A1	2/2015	Takemura et al.	2017/0132785	A1	5/2017	Wshah et al.
2015/0053737	A1	2/2015	Leimbach et al.	2017/0143284	A1	5/2017	Sehnert et al.
2015/0066000	A1	3/2015	An et al.	2017/0143442	A1	5/2017	Tesar et al.
2015/0070187	A1	3/2015	Wiesner et al.	2017/0151026	A1	6/2017	Panescu et al.
2015/0108198	A1	4/2015	Estrella et al.	2017/0156076	A1	6/2017	Eom et al.
2015/0122870	A1	5/2015	Zemlok et al.	2017/0164997	A1	6/2017	Johnson et al.
2015/0133945	A1	5/2015	Dushyant et al.	2017/0165012	A1	6/2017	Chaplin et al.
2015/0196295	A1	7/2015	Shelton, IV et al.	2017/0165725	A1	6/2017	Hersey et al.
2015/0199109	A1	7/2015	Lee	2017/0171231	A1	6/2017	Reybok, Jr. et al.
2015/0238355	A1	8/2015	Vezzu et al.	2017/0172565	A1	6/2017	Heneveld
2015/0272557	A1	10/2015	Overmyer et al.	2017/0172614	A1	6/2017	Scheib et al.
2015/0272571	A1	10/2015	Leimbach et al.	2017/0177807	A1	6/2017	Fabian
2015/0272580	A1	10/2015	Leimbach et al.	2017/0181745	A1	6/2017	Penna et al.
2015/0272582	A1	10/2015	Leimbach et al.	2017/0196637	A1	7/2017	Shelton, IV et al.
2015/0297200	A1	10/2015	Fitzsimmons et al.	2017/0202591	A1	7/2017	Shelton, IV et al.
2015/0297222	A1	10/2015	Huitema et al.	2017/0202605	A1	7/2017	Shelton, IV et al.
2015/0297228	A1	10/2015	Huitema et al.	2017/0202607	A1	7/2017	Shelton, IV et al.
2015/0297233	A1	10/2015	Huitema et al.	2017/0202609	A1	7/2017	Shelton, IV et al.
2015/0297311	A1	10/2015	Tesar	2017/0224332	A1	8/2017	Hunter et al.
2015/0302157	A1	10/2015	Collar et al.	2017/0224334	A1	8/2017	Worthington et al.
2015/0310174	A1	10/2015	Coudert et al.	2017/0224428	A1	8/2017	Kopp
2015/0313538	A1	11/2015	Bechtel et al.	2017/0231627	A1	8/2017	Shelton, IV et al.
2015/0317899	A1	11/2015	Dumbauld et al.	2017/0231628	A1	8/2017	Shelton, IV et al.
2015/0332003	A1	11/2015	Stamm et al.	2017/0245809	A1	8/2017	Ma et al.
2015/0332196	A1	11/2015	Stiller et al.	2017/0249432	A1	8/2017	Grantcharov
2015/0374369	A1	12/2015	Yates et al.	2017/0252095	A1	9/2017	Johnson
2016/0000437	A1	1/2016	Giordano et al.	2017/0255751	A1	9/2017	Sanmugalingham
2016/0015471	A1	1/2016	Piron et al.	2017/0262604	A1	9/2017	Francois
2016/0034648	A1	2/2016	Mohlenbrock et al.	2017/0265864	A1	9/2017	Hessler et al.
2016/0038253	A1	2/2016	Piron et al.	2017/0273715	A1	9/2017	Piron et al.
2016/0066913	A1	3/2016	Swayze et al.	2017/0281164	A1	10/2017	Harris et al.
2016/0078190	A1	3/2016	Greene et al.	2017/0281169	A1	10/2017	Harris et al.
2016/0106516	A1	4/2016	Mesallum	2017/0281171	A1	10/2017	Shelton, IV et al.
2016/0106934	A1	4/2016	Hiraga et al.	2017/0281173	A1	10/2017	Shelton, IV et al.
2016/0166256	A1	6/2016	Baxter, III et al.	2017/0281174	A1	10/2017	Harris et al.
2016/0180045	A1	6/2016	Syed	2017/0281186	A1	10/2017	Shelton, IV et al.
				2017/0281187	A1	10/2017	Shelton, IV et al.
				2017/0281189	A1	10/2017	Nalagatla et al.
				2017/0290585	A1	10/2017	Shelton, IV et al.
				2017/0290586	A1	10/2017	Wellman

(56)

References Cited

U.S. PATENT DOCUMENTS

2017/0296169	A1	10/2017	Yates et al.	2018/0168627	A1	6/2018	Weaner et al.
2017/0296173	A1	10/2017	Shelton, IV et al.	2018/0168628	A1	6/2018	Hunter et al.
2017/0296177	A1	10/2017	Harris et al.	2018/0168629	A1	6/2018	Shelton, IV et al.
2017/0296185	A1	10/2017	Swensgard et al.	2018/0168630	A1	6/2018	Shelton, IV et al.
2017/0296213	A1	10/2017	Swensgard et al.	2018/0168632	A1	6/2018	Harris et al.
2017/0303984	A1	10/2017	Malackowski	2018/0168633	A1	6/2018	Shelton, IV et al.
2017/0304020	A1	10/2017	Ng et al.	2018/0168637	A1	6/2018	Harris et al.
2017/0312456	A1	11/2017	Phillips	2018/0168639	A1	6/2018	Shelton, IV et al.
2017/0325813	A1	11/2017	Aranyi et al.	2018/0168643	A1	6/2018	Shelton, IV et al.
2017/0325876	A1	11/2017	Nakadate et al.	2018/0168647	A1	6/2018	Shelton, IV et al.
2017/0354470	A1	12/2017	Farritor et al.	2018/0168648	A1	6/2018	Shelton, IV et al.
2017/0360438	A1	12/2017	Cappola	2018/0168649	A1	6/2018	Shelton, IV et al.
2017/0360439	A1	12/2017	Chen et al.	2018/0168650	A1	6/2018	Shelton, IV et al.
2017/0360499	A1	12/2017	Greep et al.	2018/0168651	A1	6/2018	Shelton, IV et al.
2017/0367695	A1	12/2017	Shelton, IV et al.	2018/0168748	A1	6/2018	Kapadia
2017/0367696	A1	12/2017	Shelton, IV et al.	2018/0168763	A1	6/2018	Scheib et al.
2017/0367697	A1	12/2017	Shelton, IV et al.	2018/0177557	A1	6/2018	Kapadia et al.
2017/0367698	A1	12/2017	Shelton, IV et al.	2018/0199995	A1	7/2018	Odermatt et al.
2017/0367754	A1	12/2017	Narisawa	2018/0214025	A1	8/2018	Homyk et al.
2017/0367771	A1	12/2017	Tako et al.	2018/0221598	A1	8/2018	Silver
2017/0370710	A1	12/2017	Chen et al.	2018/0228557	A1	8/2018	Darisse et al.
2018/0008260	A1	1/2018	Baxter, III et al.	2018/0235719	A1	8/2018	Jarc
2018/0008359	A1	1/2018	Randle	2018/0242967	A1	8/2018	Meade
2018/0011983	A1	1/2018	Zuhars et al.	2018/0250080	A1	9/2018	Kopp
2018/0014848	A1	1/2018	Messerly et al.	2018/0250084	A1	9/2018	Kopp et al.
2018/0049817	A1	2/2018	Swayze et al.	2018/0263710	A1	9/2018	Sakaguchi et al.
2018/0050196	A1	2/2018	Pawsey et al.	2018/0263717	A1	9/2018	Kopp
2018/0055529	A1	3/2018	Messerly et al.	2018/0268320	A1	9/2018	Shekhar
2018/0064498	A1	3/2018	Kapadia et al.	2018/0271520	A1	9/2018	Shelton, IV et al.
2018/0065248	A1	3/2018	Barral et al.	2018/0271603	A1	9/2018	Nir et al.
2018/0098816	A1	4/2018	Govari et al.	2018/0296286	A1	10/2018	Peine et al.
2018/0110523	A1	4/2018	Shelton, IV	2018/0304471	A1	10/2018	Tokuchi
2018/0116662	A1	5/2018	Shelton, IV et al.	2018/0310935	A1	11/2018	Wixey
2018/0116735	A1	5/2018	Tierney et al.	2018/0310986	A1	11/2018	Batchelor et al.
2018/0122506	A1	5/2018	Grantcharov et al.	2018/0310997	A1	11/2018	Peine et al.
2018/0125590	A1	5/2018	Giordano et al.	2018/0317826	A1	11/2018	Muhsin et al.
2018/0132895	A1	5/2018	Silver	2018/0317915	A1	11/2018	McDonald, II
2018/0153574	A1	6/2018	Faller et al.	2018/0338806	A1	11/2018	Grubbs
2018/0153628	A1	6/2018	Grover et al.	2018/0351987	A1	12/2018	Patel et al.
2018/0153632	A1	6/2018	Tokarchuk et al.	2018/0358112	A1	12/2018	Sharifi Sedeh et al.
2018/0154297	A1	6/2018	Maletich et al.	2018/0360449	A1	12/2018	Shelton, IV et al.
2018/0161716	A1	6/2018	Li et al.	2018/0360452	A1	12/2018	Shelton, IV et al.
2018/0168575	A1	6/2018	Simms et al.	2018/0360454	A1	12/2018	Shelton, IV et al.
2018/0168577	A1	6/2018	Aronhalt et al.	2018/0360456	A1	12/2018	Shelton, IV et al.
2018/0168578	A1	6/2018	Aronhalt et al.	2018/0368930	A1	12/2018	Esterberg et al.
2018/0168579	A1	6/2018	Aronhalt et al.	2018/0369511	A1	12/2018	Zergiebel et al.
2018/0168584	A1	6/2018	Harris et al.	2019/0000446	A1	1/2019	Shelton, IV et al.
2018/0168586	A1	6/2018	Shelton, IV et al.	2019/0000448	A1	1/2019	Shelton, IV et al.
2018/0168589	A1	6/2018	Swayze et al.	2019/0000465	A1	1/2019	Shelton, IV et al.
2018/0168590	A1	6/2018	Overmyer et al.	2019/0000478	A1	1/2019	Messerly et al.
2018/0168591	A1	6/2018	Swayze et al.	2019/0000530	A1	1/2019	Yates et al.
2018/0168592	A1	6/2018	Overmyer et al.	2019/0000565	A1	1/2019	Shelton, IV et al.
2018/0168593	A1	6/2018	Overmyer et al.	2019/0000569	A1	1/2019	Crawford et al.
2018/0168594	A1	6/2018	Shelton, IV et al.	2019/0001079	A1	1/2019	Zergiebel et al.
2018/0168597	A1	6/2018	Fanelli et al.	2019/0005641	A1	1/2019	Yamamoto
2018/0168598	A1	6/2018	Shelton, IV et al.	2019/0006047	A1	1/2019	Gorek et al.
2018/0168600	A1	6/2018	Shelton, IV et al.	2019/0008600	A1	1/2019	Pedros et al.
2018/0168601	A1	6/2018	Bakos et al.	2019/0025040	A1	1/2019	Andreason et al.
2018/0168603	A1	6/2018	Morgan et al.	2019/0029712	A1	1/2019	Stoddard et al.
2018/0168605	A1	6/2018	Baber et al.	2019/0038335	A1	2/2019	Mohr et al.
2018/0168606	A1	6/2018	Shelton, IV et al.	2019/0038364	A1	2/2019	Enoki
2018/0168607	A1	6/2018	Shelton, IV et al.	2019/0053801	A1	2/2019	Wixey et al.
2018/0168608	A1	6/2018	Shelton, IV et al.	2019/0053866	A1	2/2019	Seow et al.
2018/0168609	A1	6/2018	Fanelli et al.	2019/0054620	A1	2/2019	Griffiths et al.
2018/0168610	A1	6/2018	Shelton, IV et al.	2019/0069949	A1	3/2019	Vrba et al.
2018/0168614	A1	6/2018	Shelton, IV et al.	2019/0069964	A1	3/2019	Hagn
2018/0168615	A1	6/2018	Shelton, IV et al.	2019/0070550	A1	3/2019	Lalomia et al.
2018/0168616	A1	6/2018	Shelton, IV et al.	2019/0070731	A1	3/2019	Bowling et al.
2018/0168617	A1	6/2018	Shelton, IV et al.	2019/0087544	A1	3/2019	Peterson
2018/0168618	A1	6/2018	Scott et al.	2019/0090969	A1	3/2019	Jarc et al.
2018/0168619	A1	6/2018	Scott et al.	2019/0099180	A1	4/2019	Leimbach et al.
2018/0168621	A1	6/2018	Shelton, IV et al.	2019/0099227	A1	4/2019	Rockrohr
2018/0168623	A1	6/2018	Simms et al.	2019/0104919	A1	4/2019	Shelton, IV et al.
2018/0168624	A1	6/2018	Shelton, IV et al.	2019/0125320	A1	5/2019	Shelton, IV et al.
2018/0168625	A1	6/2018	Posada et al.	2019/0125321	A1	5/2019	Shelton, IV et al.
				2019/0125324	A1	5/2019	Scheib et al.
				2019/0125335	A1	5/2019	Shelton, IV et al.
				2019/0125336	A1	5/2019	Deck et al.
				2019/0125337	A1	5/2019	Shelton, IV et al.

(56)

References Cited

U.S. PATENT DOCUMENTS

2019/0125338	A1	5/2019	Shelton, IV et al.	2019/0201033	A1	7/2019	Yates et al.
2019/0125339	A1	5/2019	Shelton, IV et al.	2019/0201034	A1	7/2019	Shelton, IV et al.
2019/0125344	A1	5/2019	DiNardo et al.	2019/0201036	A1	7/2019	Nott et al.
2019/0125347	A1	5/2019	Stokes et al.	2019/0201037	A1	7/2019	Houser et al.
2019/0125348	A1	5/2019	Shelton, IV et al.	2019/0201038	A1	7/2019	Yates et al.
2019/0125353	A1	5/2019	Shelton, IV et al.	2019/0201039	A1	7/2019	Widenhouse et al.
2019/0125354	A1	5/2019	Deck et al.	2019/0201040	A1	7/2019	Messerly et al.
2019/0125355	A1	5/2019	Shelton, IV et al.	2019/0201041	A1	7/2019	Kimball et al.
2019/0125356	A1	5/2019	Shelton, IV et al.	2019/0201042	A1	7/2019	Nott et al.
2019/0125357	A1	5/2019	Shelton, IV et al.	2019/0201043	A1	7/2019	Shelton, IV et al.
2019/0125358	A1	5/2019	Shelton, IV et al.	2019/0201044	A1	7/2019	Shelton, IV et al.
2019/0125359	A1	5/2019	Shelton, IV et al.	2019/0201045	A1	7/2019	Yates et al.
2019/0125360	A1	5/2019	Shelton, IV et al.	2019/0201046	A1	7/2019	Shelton, IV et al.
2019/0125361	A1	5/2019	Shelton, IV et al.	2019/0201047	A1	7/2019	Yates et al.
2019/0125377	A1	5/2019	Shelton, IV	2019/0201073	A1	7/2019	Nott et al.
2019/0125378	A1	5/2019	Shelton, IV et al.	2019/0201074	A1	7/2019	Yates et al.
2019/0125379	A1	5/2019	Shelton, IV et al.	2019/0201075	A1	7/2019	Shelton, IV et al.
2019/0125380	A1	5/2019	Hunter et al.	2019/0201077	A1	7/2019	Yates et al.
2019/0125381	A1	5/2019	Scheib et al.	2019/0201079	A1	7/2019	Shelton, IV et al.
2019/0125382	A1	5/2019	Scheib et al.	2019/0201080	A1	7/2019	Messerly et al.
2019/0125383	A1	5/2019	Scheib et al.	2019/0201081	A1	7/2019	Shelton, IV et al.
2019/0125384	A1	5/2019	Scheib et al.	2019/0201082	A1	7/2019	Shelton, IV et al.
2019/0125385	A1	5/2019	Scheib et al.	2019/0201083	A1	7/2019	Shelton, IV et al.
2019/0125386	A1	5/2019	Shelton, IV et al.	2019/0201084	A1	7/2019	Shelton, IV et al.
2019/0125387	A1	5/2019	Parihar et al.	2019/0201085	A1	7/2019	Shelton, IV et al.
2019/0125388	A1	5/2019	Shelton, IV et al.	2019/0201086	A1	7/2019	Shelton, IV et al.
2019/0125389	A1	5/2019	Shelton, IV et al.	2019/0201087	A1	7/2019	Shelton, IV et al.
2019/0125390	A1	5/2019	Shelton, IV et al.	2019/0201088	A1	7/2019	Shelton, IV et al.
2019/0125430	A1	5/2019	Shelton, IV et al.	2019/0201090	A1	7/2019	Shelton, IV et al.
2019/0125431	A1	5/2019	Shelton, IV et al.	2019/0201091	A1	7/2019	Yates et al.
2019/0125432	A1	5/2019	Shelton, IV et al.	2019/0201092	A1	7/2019	Yates et al.
2019/0125454	A1	5/2019	Stokes et al.	2019/0201102	A1	7/2019	Shelton, IV et al.
2019/0125455	A1	5/2019	Shelton, IV et al.	2019/0201104	A1	7/2019	Shelton, IV et al.
2019/0125456	A1	5/2019	Shelton, IV et al.	2019/0201105	A1	7/2019	Shelton, IV et al.
2019/0125457	A1	5/2019	Parihar et al.	2019/0201111	A1	7/2019	Shelton, IV et al.
2019/0125458	A1	5/2019	Shelton, IV et al.	2019/0201112	A1	7/2019	Wiener et al.
2019/0125459	A1	5/2019	Shelton, IV et al.	2019/0201113	A1	7/2019	Shelton, IV et al.
2019/0125476	A1	5/2019	Shelton, IV et al.	2019/0201114	A1	7/2019	Shelton, IV et al.
2019/0133703	A1	5/2019	Seow et al.	2019/0201115	A1	7/2019	Shelton, IV et al.
2019/0142449	A1	5/2019	Shelton, IV et al.	2019/0201116	A1	7/2019	Shelton, IV et al.
2019/0142535	A1	5/2019	Seow et al.	2019/0201117	A1	7/2019	Yates et al.
2019/0145942	A1	5/2019	Dutriez et al.	2019/0201118	A1	7/2019	Shelton, IV et al.
2019/0150975	A1	5/2019	Kawasaki et al.	2019/0201119	A1	7/2019	Harris et al.
2019/0159777	A1	5/2019	Ehrenfels et al.	2019/0201120	A1	7/2019	Shelton, IV et al.
2019/0159778	A1	5/2019	Shelton, IV et al.	2019/0201122	A1	7/2019	Shelton, IV et al.
2019/0162179	A1	5/2019	O'Shea et al.	2019/0201123	A1	7/2019	Shelton, IV et al.
2019/0164285	A1	5/2019	Nye et al.	2019/0201124	A1	7/2019	Shelton, IV et al.
2019/0192157	A1	6/2019	Scott et al.	2019/0201125	A1	7/2019	Shelton, IV et al.
2019/0192236	A1	6/2019	Shelton, IV et al.	2019/0201126	A1	7/2019	Shelton, IV et al.
2019/0200844	A1	7/2019	Shelton, IV et al.	2019/0201127	A1	7/2019	Shelton, IV et al.
2019/0200863	A1	7/2019	Shelton, IV et al.	2019/0201128	A1	7/2019	Yates et al.
2019/0200905	A1	7/2019	Shelton, IV et al.	2019/0201129	A1	7/2019	Shelton, IV et al.
2019/0200906	A1	7/2019	Shelton, IV et al.	2019/0201130	A1	7/2019	Shelton, IV et al.
2019/0200977	A1	7/2019	Shelton, IV et al.	2019/0201135	A1	7/2019	Shelton, IV et al.
2019/0200980	A1	7/2019	Shelton, IV et al.	2019/0201136	A1	7/2019	Shelton, IV et al.
2019/0200981	A1	7/2019	Harris et al.	2019/0201137	A1	7/2019	Shelton, IV et al.
2019/0200984	A1	7/2019	Shelton, IV et al.	2019/0201138	A1	7/2019	Yates et al.
2019/0200985	A1	7/2019	Shelton, IV et al.	2019/0201139	A1	7/2019	Shelton, IV et al.
2019/0200986	A1	7/2019	Shelton, IV et al.	2019/0201140	A1	7/2019	Yates et al.
2019/0200987	A1	7/2019	Shelton, IV et al.	2019/0201141	A1	7/2019	Shelton, IV et al.
2019/0200988	A1	7/2019	Shelton, IV	2019/0201142	A1	7/2019	Shelton, IV et al.
2019/0200996	A1	7/2019	Shelton, IV et al.	2019/0201143	A1	7/2019	Shelton, IV et al.
2019/0200997	A1	7/2019	Shelton, IV et al.	2019/0201144	A1	7/2019	Shelton, IV et al.
2019/0200998	A1	7/2019	Shelton, IV et al.	2019/0201145	A1	7/2019	Shelton, IV et al.
2019/0201018	A1	7/2019	Shelton, IV et al.	2019/0201146	A1	7/2019	Shelton, IV et al.
2019/0201020	A1	7/2019	Shelton, IV et al.	2019/0201158	A1	7/2019	Shelton, IV et al.
2019/0201021	A1	7/2019	Shelton, IV et al.	2019/0201159	A1	7/2019	Shelton, IV et al.
2019/0201023	A1	7/2019	Shelton, IV et al.	2019/0201593	A1	7/2019	Shelton, IV et al.
2019/0201024	A1	7/2019	Shelton, IV et al.	2019/0201594	A1	7/2019	Shelton, IV et al.
2019/0201025	A1	7/2019	Shelton, IV et al.	2019/0201597	A1	7/2019	Shelton, IV et al.
2019/0201026	A1	7/2019	Shelton, IV et al.	2019/0204201	A1	7/2019	Shelton, IV et al.
2019/0201027	A1	7/2019	Shelton, IV et al.	2019/0205001	A1	7/2019	Messerly et al.
2019/0201028	A1	7/2019	Shelton, IV et al.	2019/0205441	A1	7/2019	Shelton, IV et al.
2019/0201029	A1	7/2019	Shelton, IV et al.	2019/0205566	A1	7/2019	Shelton, IV et al.
2019/0201030	A1	7/2019	Shelton, IV et al.	2019/0205567	A1	7/2019	Shelton, IV et al.
				2019/0206003	A1	7/2019	Harris et al.
				2019/0206004	A1	7/2019	Shelton, IV et al.
				2019/0206050	A1	7/2019	Yates et al.
				2019/0206216	A1	7/2019	Shelton, IV et al.

(56)

References Cited

U.S. PATENT DOCUMENTS

2019/0206542	A1	7/2019	Shelton, IV et al.	2020/0162896	A1	5/2020	Su et al.
2019/0206551	A1	7/2019	Yates et al.	2020/0178971	A1	6/2020	Harris et al.
2019/0206555	A1	7/2019	Morgan et al.	2020/0261075	A1	8/2020	Boudreaux et al.
2019/0206556	A1	7/2019	Shelton, IV et al.	2020/0261076	A1	8/2020	Boudreaux et al.
2019/0206561	A1	7/2019	Shelton, IV et al.	2020/0261077	A1	8/2020	Shelton, IV et al.
2019/0206562	A1	7/2019	Shelton, IV et al.	2020/0261078	A1	8/2020	Bakos et al.
2019/0206563	A1	7/2019	Shelton, IV et al.	2020/0261080	A1	8/2020	Bakos et al.
2019/0206564	A1	7/2019	Shelton, IV et al.	2020/0261081	A1	8/2020	Boudreaux et al.
2019/0206565	A1	7/2019	Shelton, IV	2020/0261082	A1	8/2020	Boudreaux et al.
2019/0206569	A1	7/2019	Shelton, IV et al.	2020/0261083	A1	8/2020	Bakos et al.
2019/0206576	A1	7/2019	Shelton, IV et al.	2020/0261084	A1	8/2020	Bakos et al.
2019/0207773	A1	7/2019	Shelton, IV et al.	2020/0261085	A1	8/2020	Boudreaux et al.
2019/0207857	A1	7/2019	Shelton, IV et al.	2020/0261086	A1	8/2020	Zeiner et al.
2019/0207911	A1	7/2019	Wiener et al.	2020/0261087	A1	8/2020	Timm et al.
2019/0208641	A1	7/2019	Yates et al.	2020/0261088	A1	8/2020	Harris et al.
2019/0223291	A1	7/2019	Seow et al.	2020/0261089	A1	8/2020	Shelton, IV et al.
2019/0254759	A1	8/2019	Azizian	2020/0275930	A1	9/2020	Harris et al.
2019/0261984	A1	8/2019	Nelson et al.	2020/0281665	A1	9/2020	Kopp
2019/0269476	A1	9/2019	Bowling et al.	2020/0405375	A1	12/2020	Shelton, IV et al.
2019/0274662	A1	9/2019	Rockman et al.	2021/0000555	A1	1/2021	Shelton, IV et al.
2019/0274705	A1	9/2019	Sawhney et al.	2021/0015568	A1	1/2021	Liao et al.
2019/0274706	A1	9/2019	Nott et al.	2021/0022738	A1	1/2021	Weir et al.
2019/0274707	A1	9/2019	Sawhney et al.	2021/0022809	A1	1/2021	Crawford et al.
2019/0274708	A1	9/2019	Boudreaux				
2019/0274709	A1	9/2019	Scoggins				
2019/0274710	A1	9/2019	Black				
2019/0274711	A1	9/2019	Scoggins et al.	CN	101617950	A	1/2010
2019/0274712	A1	9/2019	Faller et al.	CN	104490448	B	3/2017
2019/0274713	A1	9/2019	Scoggins et al.	CN	206097107	U	4/2017
2019/0274714	A1	9/2019	Cuti et al.	CN	108652695	A	10/2018
2019/0274716	A1	9/2019	Nott et al.	DE	2037167	A1	7/1980
2019/0274717	A1	9/2019	Nott et al.	DE	3824913	A1	2/1990
2019/0274718	A1	9/2019	Denzinger et al.	DE	4002843	C1	4/1991
2019/0274719	A1	9/2019	Stulen	DE	102005051367	A1	4/2007
2019/0274720	A1	9/2019	Gee et al.	DE	102016207666	A1	11/2017
2019/0274749	A1	9/2019	Brady et al.	EP	0000756	B1	10/1981
2019/0274750	A1	9/2019	Jayne et al.	EP	2732772	A1	5/2014
2019/0274752	A1	9/2019	Denzinger et al.	EP	2942023	A2	11/2015
2019/0290389	A1	9/2019	Kopp	EP	3047806	A1	7/2016
2019/0298340	A1	10/2019	Shelton, IV et al.	EP	3056923	A1	8/2016
2019/0298341	A1	10/2019	Shelton, IV et al.	EP	3095399	A2	11/2016
2019/0298342	A1	10/2019	Shelton, IV et al.	EP	3120781	A2	1/2017
2019/0298343	A1	10/2019	Shelton, IV et al.	EP	3135225	A2	3/2017
2019/0298346	A1	10/2019	Shelton, IV et al.	EP	3141181	A1	3/2017
2019/0298347	A1	10/2019	Shelton, IV et al.	GB	2509523	A	7/2014
2019/0298350	A1	10/2019	Shelton, IV et al.	JP	S5373315	A	6/1978
2019/0298351	A1	10/2019	Shelton, IV et al.	JP	2017513561	A	6/2017
2019/0298352	A1	10/2019	Shelton, IV et al.	KR	20140104587	A	8/2014
2019/0298353	A1	10/2019	Shelton, IV et al.	KR	101587721	B1	1/2016
2019/0298354	A1	10/2019	Shelton, IV et al.	WO	WO-9734533	A1	9/1997
2019/0298355	A1	10/2019	Shelton, IV et al.	WO	WO-0024322	A1	5/2000
2019/0298356	A1	10/2019	Shelton, IV et al.	WO	WO-0108578	A1	2/2001
2019/0298357	A1	10/2019	Shelton, IV et al.	WO	WO-0112089	A1	2/2001
2019/0298464	A1	10/2019	Abbott	WO	WO-0120892	A3	11/2001
2019/0298481	A1	10/2019	Rosenberg et al.	WO	WO-03079909	A2	10/2003
2019/0307520	A1	10/2019	Peine et al.	WO	WO-2007137304	A2	11/2007
2019/0314015	A1	10/2019	Shelton, IV et al.	WO	WO-2008056618	A2	5/2008
2019/0314016	A1	10/2019	Huitema et al.	WO	WO-2008069816	A1	6/2008
2019/0321117	A1	10/2019	Itkowitz et al.	WO	WO-2008147555	A2	12/2008
2019/0333626	A1	10/2019	Mansi et al.	WO	WO-2011112931	A1	9/2011
2019/0343594	A1	11/2019	Garcia Kilroy et al.	WO	WO-2013143573	A1	10/2013
2019/0374140	A1	12/2019	Tucker et al.	WO	WO-2014134196	A1	9/2014
2020/0054317	A1	2/2020	Pisarnwongs et al.	WO	WO-2015129395	A1	9/2015
2020/0054320	A1	2/2020	Harris et al.	WO	WO-2016100719	A1	6/2016
2020/0054321	A1	2/2020	Harris et al.	WO	WO-2016206015	A1	12/2016
2020/0054322	A1	2/2020	Harris et al.	WO	WO-2017011382	A1	1/2017
2020/0054323	A1	2/2020	Harris et al.	WO	WO-2017011646	A1	1/2017
2020/0054325	A1	2/2020	Harris et al.	WO	WO-2017058695	A1	4/2017
2020/0054326	A1	2/2020	Harris et al.	WO	WO-2017151996	A1	9/2017
2020/0054327	A1	2/2020	Harris et al.	WO	WO-2017189317	A1	11/2017
2020/0054328	A1	2/2020	Harris et al.	WO	WO-2017205308	A1	11/2017
2020/0054329	A1	2/2020	Shelton, IV et al.	WO	WO-2017210499	A1	12/2017
2020/0054330	A1	2/2020	Harris et al.				
2020/0054331	A1	2/2020	Harris et al.				
2020/0100830	A1	4/2020	Henderson et al.				

FOREIGN PATENT DOCUMENTS

(56)

References Cited

FOREIGN PATENT DOCUMENTS

WO WO-2017210501 A1 12/2017
 WO WO-2018152141 A1 8/2018

OTHER PUBLICATIONS

Flores et al., "Large-scale Offloading in the Internet of Things," 2017 IEEE International Conference on Pervasive Computing and Communications Workshops (PERCOM Workshops), IEEE, pp. 479-484, Mar. 13, 2017.

Kalantarian et al., "Computation Offloading for Real-Time Health-Monitoring Devices," 2016 38th Annual International Conference of the IEEE Engineering in Medicine and Biology Society (EBMC), IEEE, pp. 4971-4974, Aug. 16, 2016.

Yuyi Mao et al., "A Survey on Mobile Edge Computing: The Communication Perspective," IEEE Communications Surveys & Tutorials, pp. 2322-2358, Jun. 13, 2017.

Khazaei et al., "Health Informatics for Neonatal Intensive Care Units: An Analytical Modeling Perspective," IEEE Journal of Translational Engineering in Health and Medicine, vol. 3, pp. 1-9, Oct. 21, 2015.

Benkmann et al., "Concept of iterative optimization of minimally invasive surgery," 2017 22nd International Conference on Methods and Models in Automation and Robotics (MMAR), IEEE pp. 443-446, Aug. 28, 2017.

Trautman, Peter, "Breaking the Human-Robot Deadlock: Surpassing Shared Control Performance Limits with Sparse Human-Robot Interaction," Robotics: Science and Systems XIII, pp. 1-10, Jul. 12, 2017.

Yang et al., "A dynamic strategy for packet scheduling and bandwidth allocation based on channel quality in IEEE 802.16e OFDMA system," Journal of Network and Computer Applications, vol. 39, pp. 52-60, May 2, 2013.

Takahashi et al., "Automatic smoke evacuation in laparoscopic surgery: a simplified method for objective evaluation," Surgical Endoscopy, vol. 27, No. 8, pp. 2980-2987, Feb. 23, 2013.

Miksch et al., "Utilizing temporal data abstraction for data validation and therapy planning for artificially ventilated newborn infants," Artificial Intelligence in Medicine, vol. 8, No. 6, pp. 543-576 (1996).

Horn et al., "Effective data validation of high-frequency data: Time-point-time-interval-, and trend-based methods," Computers in Biology and Medic, New York, NY, vol. 27, No. 5, pp. 389-409 (1997).

Stacey et al., "Temporal abstraction in intelligent clinical data analysis: A survey," Artificial Intelligence in Medicine, vol. 39, No. 1, pp. 1-24 (2006).

Zoccali, Bruno, "A Method for Approximating Component Temperatures at Altitude Conditions Based on CFD Analysis at Sea Level Conditions," (white paper), www.tdmginc.com, Dec. 6, 2018 (9 pages).

Slocinski et al., "Distance measure for impedance spectra for quantified evaluations," Lecture Notes on Impedance Spectroscopy, vol. 3, Taylor and Francis Group (Jul. 2012)—Book Not Attached.

Engel et al. "A safe robot system for craniofacial surgery", 2013 IEEE International Conference on Robotics and Automation (ICRA); May 6-10, 2013; Karlsruhe, Germany, vol. 2, Jan. 1, 2001, pp. 2020-2024.

Bonaci et al., "To Make a Robot Secure: An Experimental Analysis of Cyber Security Threats Against Teleoperated Surgical Robots," May 13, 2015. Retrieved from the Internet: URL:<https://arxiv.org/pdf/1504.04339v2.pdf> [retrieved on Aug. 24, 2019].

Homa Alemzadeh et al., "Targeted Attacks on Teleoperated Surgical Robots: Dynamic Model-Based Detection and Mitigation," 2016 46th Annual IEEE/IFIP International Conference on Dependable Systems and Networks (DSN), IEEE, Jun. 28, 2016, pp. 395-406.

Phumzile Malindi, "5. QoS in Telemedicine," "Telemedicine," Jun. 20, 2011, IntechOpen, pp. 119-138.

Staub et al., "Contour-based Surgical Instrument Tracking Supported by Kinematic Prediction," Proceedings of the 2010 3rd IEEE RAS & EMBS International Conference on Biomedical Robotics and Biomechatronics, Sep. 1, 2010, pp. 746-752.

Allan et al., "3-D Pose Estimation of Articulated Instruments in Robotic Minimally Invasive Surgery," IEEE Transactions on Medical Imaging, vol. 37, No. 5, May 1, 2018, pp. 1204-1213.

Kassahun et al., "Surgical Robotics Beyond Enhanced Dexterity Instrumentation: A Survey of the Machine Learning Techniques and their Role in Intelligent and Autonomous Surgical Actions." International Journal of Computer Assisted Radiology and Surgery, vol. 11, No. 4, Oct. 8, 2015, pp. 553-568.

Weede et al., "An Intelligent and Autonomous Endoscopic Guidance System for Minimally Invasive Surgery," 2013 IEEE International Conference on Robotics and Automation (ICRA), May 6-10, 2013. Karlsruhe, Germany, May 1, 2011, pp. 5762-5768.

Altenberg et al., "Genes of Glycolysis are Ubiquitously Overexpressed in 24 Cancer Classes," Genomics, vol. 84, pp. 1014-1020 (2004).

Harold I. Brandon and V. Leroy Young, Mar. 1997, Surgical Services Management vol. 3 No. 3. retrieved from the internet <<https://www.surgimed.com/Research%20Articles/Electrosurgical%20Plume/Characterization%20And%20Removal%20Of%20Electrosurgical%20Smoke.pdf>> (Year: 1997).

Marshall Brain, How Microcontrollers Work, 2006, retrieved from the internet <<https://web.archive.org/web/20060221235221/http://electronics.howstuffworks.com/microcontroller.htm/printable>> (Year: 2006).

CRC Press, "The Measurement, Instrumentation and Sensors Handbook," 1999, Section VII, Chapter 41, Peter O'Shea, "Phase Measurement," pp. 1303-1321, ISBN 0-8493-2145-X.

Jiang, "'Sound of Silence': a secure indoor wireless ultrasonic communication system," Article, 2014, pp. 46-50, Snapshots of Doctoral Research at University College Cork, School of Engineering—Electrical & Electronic Engineering, UCC, Cork, Ireland.

Li, et al., "Short-range ultrasonic communications in air using quadrature modulation," Journal, Oct. 30, 2009, pp. 2060-2072, IEEE Transactions on Ultrasonics, Ferroelectrics, and Frequency Control, vol. 56, No. 10, IEEE.

Salamon, "AI Detects Polyps Better Than Colonoscopists" Online Article, Jun. 3, 2018, Medscape Medical News, Digestive Disease Week (DDW) 2018: Presentation 133.

Misawa, et al. "Artificial Intelligence-Assisted Polyp Detection for Colonoscopy: Initial Experience," Article, Jun. 2018, pp. 2027-2029, vol. 154, Issue 8, American Gastroenterology Association.

Dottorato, "Analysis and Design of the Rectangular Microstrip Patch Antennas for TM_{0n0} operating mode," Article, Oct. 8, 2010, pp. 1-9, Microwave Journal.

Miller, et al., "Impact of Powered and Tissue-Specific Endoscopic Stapling Technology on Clinical and Economic Outcomes of Video-Assisted Thoracic Surgery Lobectomy Procedures: A Retrospective, Observational Study," Article, Apr. 2018, pp. 707-723, vol. 35 (Issue 5), Advances in Therapy.

Hsiao-Wei Tang, "ARCM", Video, Sep. 2012, YouTube, 5 screenshots, Retrieved from internet: <<https://www.youtube.com/watch?v=UldQaxb3fRw&feature=youtu.be>>.

Giannios, et al., "Visible to near-infrared refractive properties of freshly-excised human-liver tissues: marking hepatic malignancies," Article, Jun. 14, 2016, pp. 1-10, Scientific Reports 6, Article No. 27910, Nature.

Vander Heiden, et al., "Understanding the Warburg effect: the metabolic requirements of cell proliferation," Article, 22 May 2009, pp. 1-12, vol. 324, Issue 5930, Science.

Hirayama et al., "Quantitative Metabolome Profiling of Colon and Stomach Cancer Microenvironment by Capillary Electrophoresis Time-of-Flight Mass Spectrometry," Article, Jun. 2009, pp. 4918-4925, vol. 69, Issue 11, Cancer Research.

Cengiz, et al., "A Tale of Two Compartments: Interstitial Versus Blood Glucose Monitoring," Article, Jun. 2009, pp. S11-S16, vol. 11, Supplement 1, Diabetes Technology & Therapeutics.

Shen, et al., "An Iridium nanoparticles dispersed carbon based thick film electrochemical biosensor and its application for a single use,

(56)

References Cited

OTHER PUBLICATIONS

disposable glucose biosensor,” Article, Feb. 3, 2007, pp. 106-113, vol. 125, Issue 1, Sensors and Actuators B: Chemical, Science Direct.

“ATM-MPLS Network Interworking Version 2.0, af-aic-0178.001” ATM Standard, The ATM Forum Technical Committee, published Aug. 2003.

IEEE Std 802.3-2012 (Revision of IEEE Std 802.3-2008, published Dec. 28, 2012).

IEEE Std No. 177, “Standard Definitions and Methods of Measurement for Piezoelectric Vibrators,” published May 1966, The Institute of Electrical and Electronics Engineers, Inc., New York, N.Y.

“Surgical instrumentation: the true cost of instrument trays and a potential strategy for optimization”; Mhlaba et al.; Sep. 23, 2015 (Year: 2015).

Anonymous, “Internet of Things Powers Connected Surgical Device Infrastructure Case Study”, Dec. 31, 2016 (Dec. 31, 2016), Retrieved from the Internet: URL:https://www.cognizant.com/services-resources/150110_IoT_connected_surgical_devices.pdf.

Anonymous: “Titanium Key Chain Tool 1.1, Ultralight Multipurpose Key Chain Tool, Forward Cutting Can Opener—Vargo Titanium,” vargooutdoors.com, Jul. 5, 2014 (Jul. 5, 2014), retrieved from the internet: <https://vargooutdoors.com/titanium-key-chain-tool-1-1.html>.

Choi et al., A haptic augmented reality surgeon console for a laparoscopic surgery robot system, 2013, IEEE, pp. 355-357 (Year: 2013).

Draijer, Matthijs et al., “Review of laser psecle contrast techniques for visualizing tissue perfusion,” *Lasers in Medical Science*, Springer-Verlag, LO, vol. 24, No. 4, Dec. 3, 2008, pp. 639-651.

Nabil Simaan et al, “Intelligent Surgical Robots with Situational Awareness: From Good to Great Surgeons”, DOI: 10.1115/1.2015-Sep-6 external link, Sep. 2015 (Sep. 2015), p. 3-6, Retrieved from the Internet: URL:<http://memagazineselect.asmedigitalcollection.asme.org/data/journals/meena/936888/me-2015-sep6.pdf> XP055530863.

Roy D Cullum, “Handbook of Engineering Design”, ISBN: 9780408005586, Jan. 1, 1988 (Jan. 1, 1988), XP055578597, ISBN: 9780408005586, 10-20, Chapter 6, p. 138, right-hand column, paragraph 3.

Shi et al., An intuitive control console for robotic syrgery system, 2014, IEEE, p. 404-407 (Year: 2014).

Sun et al., Innovative effector design for simulation training in robotic surgery, 2010, IEEE, p. 1735-1759 (Year: 2010).

Xie et al., Development of stereo vision and master-slave controller for a compact surgical robot system, 2015, IEEE, p. 403-407 (Year: 2015).

* cited by examiner

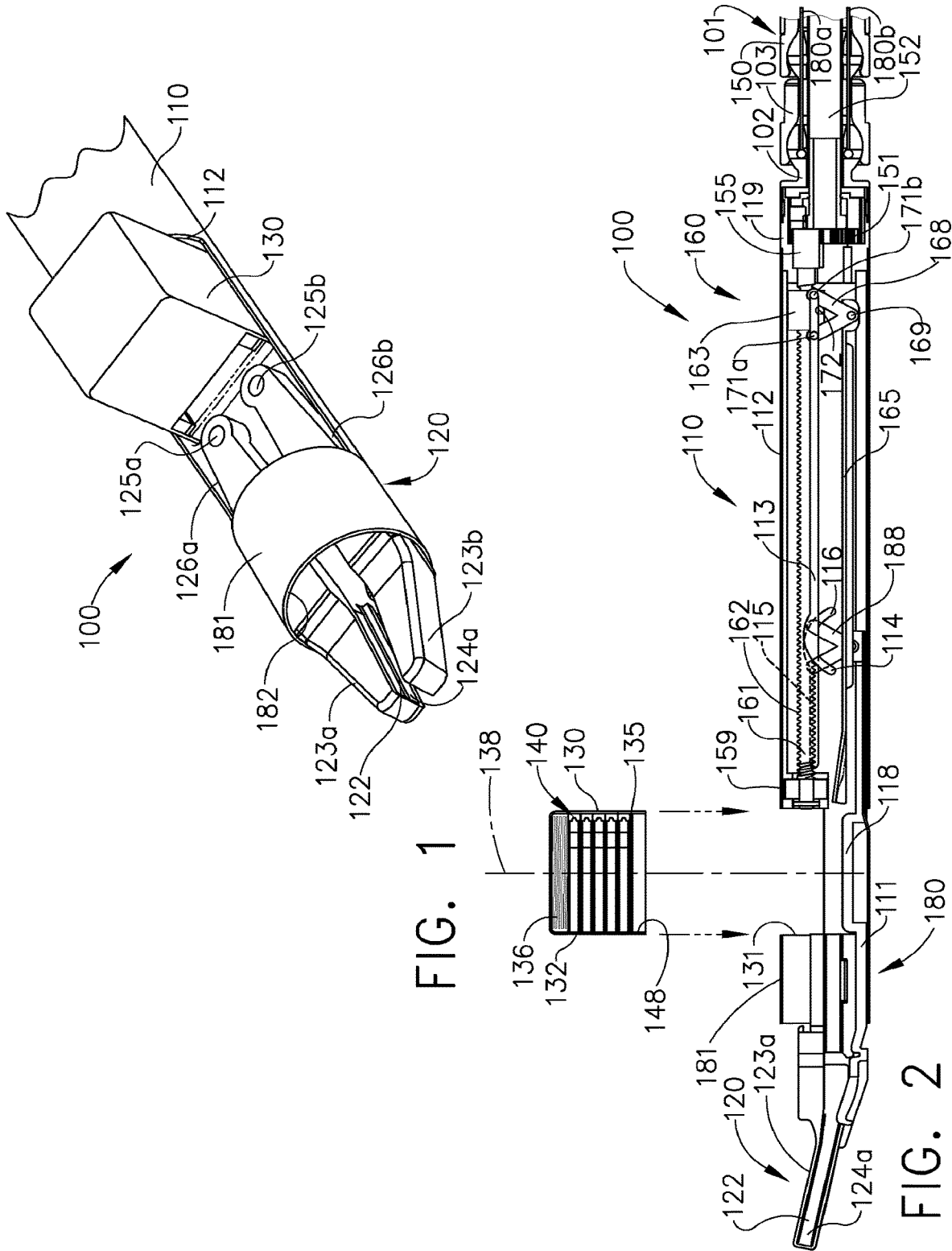

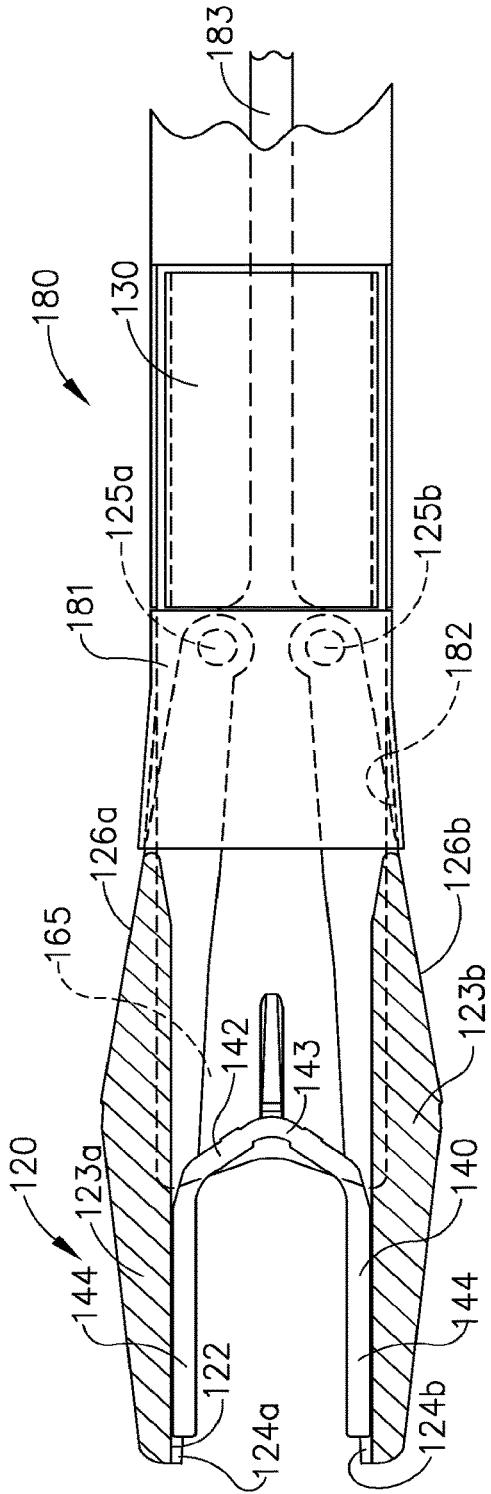

FIG. 3

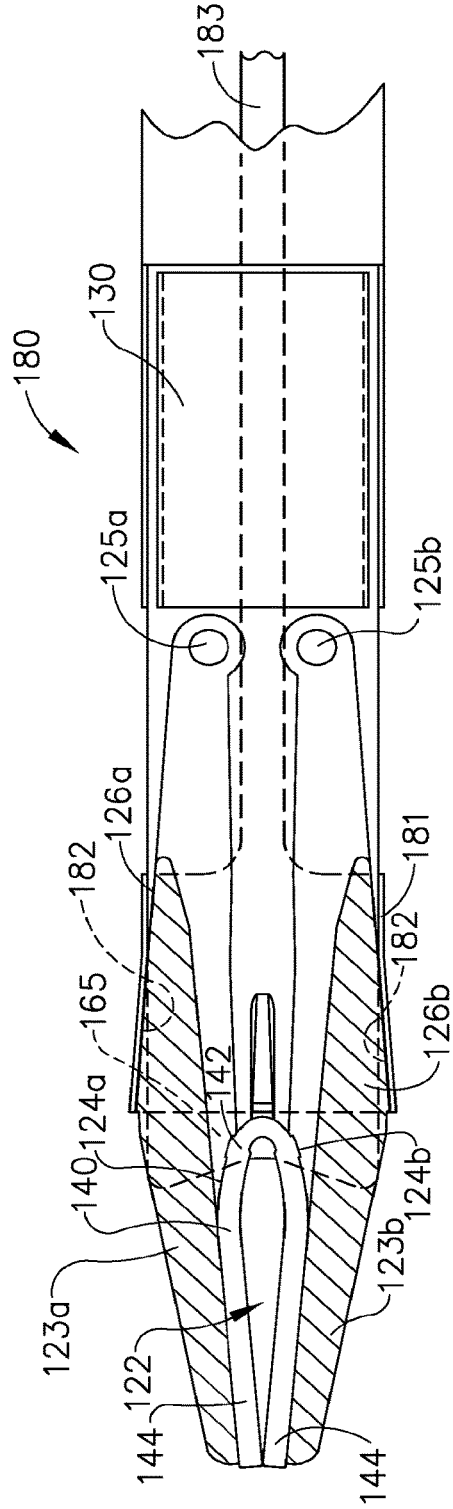

FIG. 4

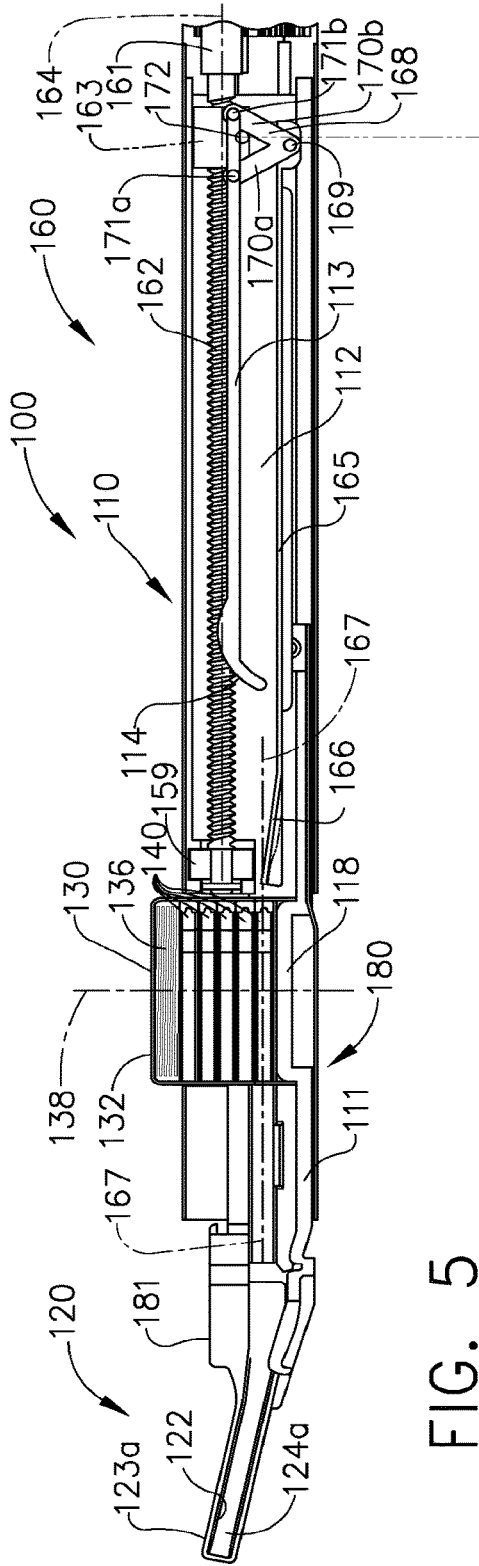

FIG. 5

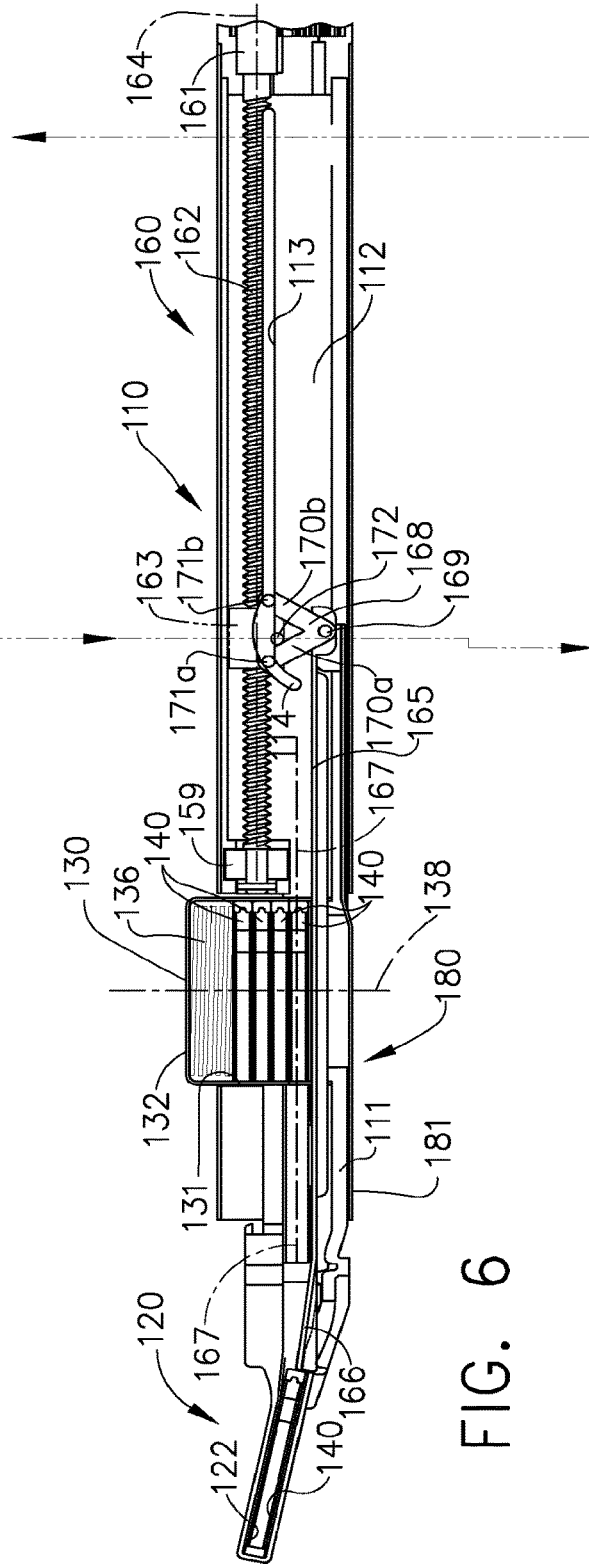

FIG. 6

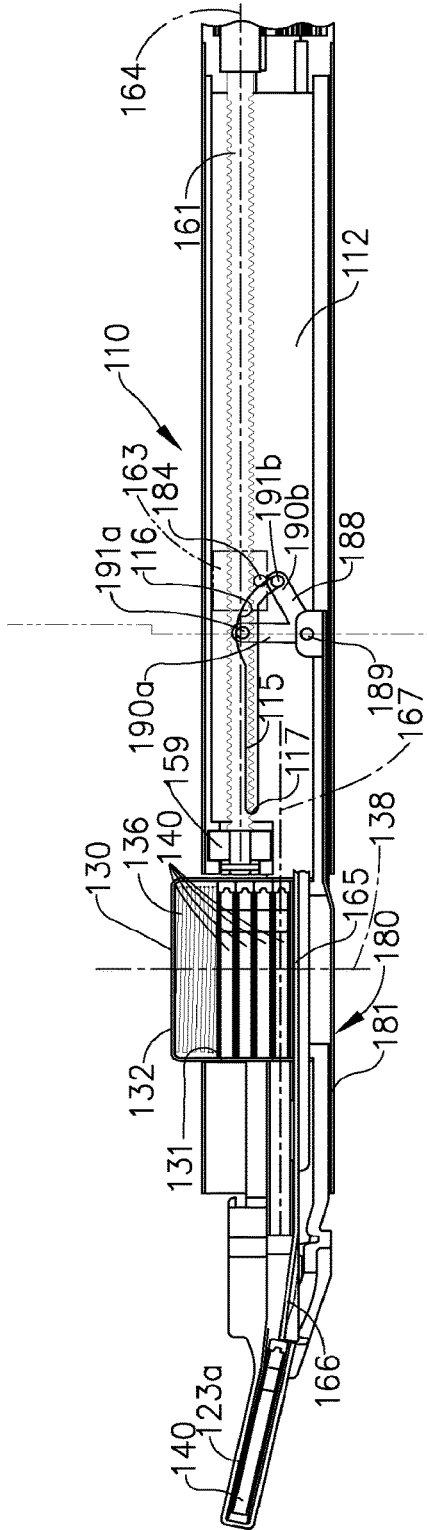

FIG. 7

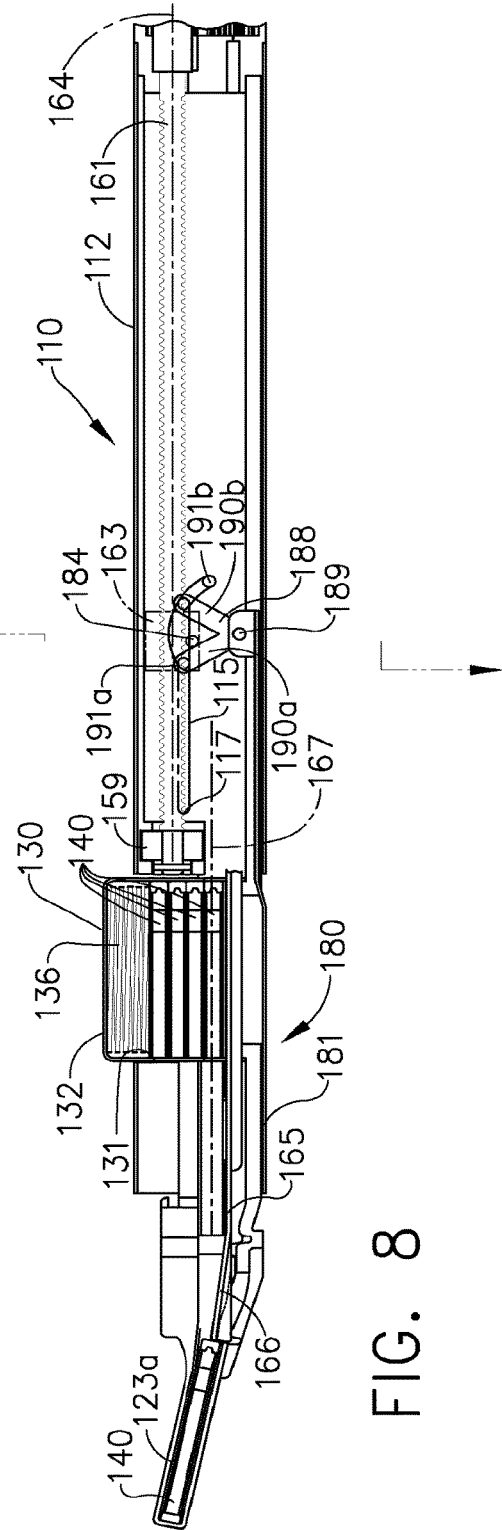

FIG. 8

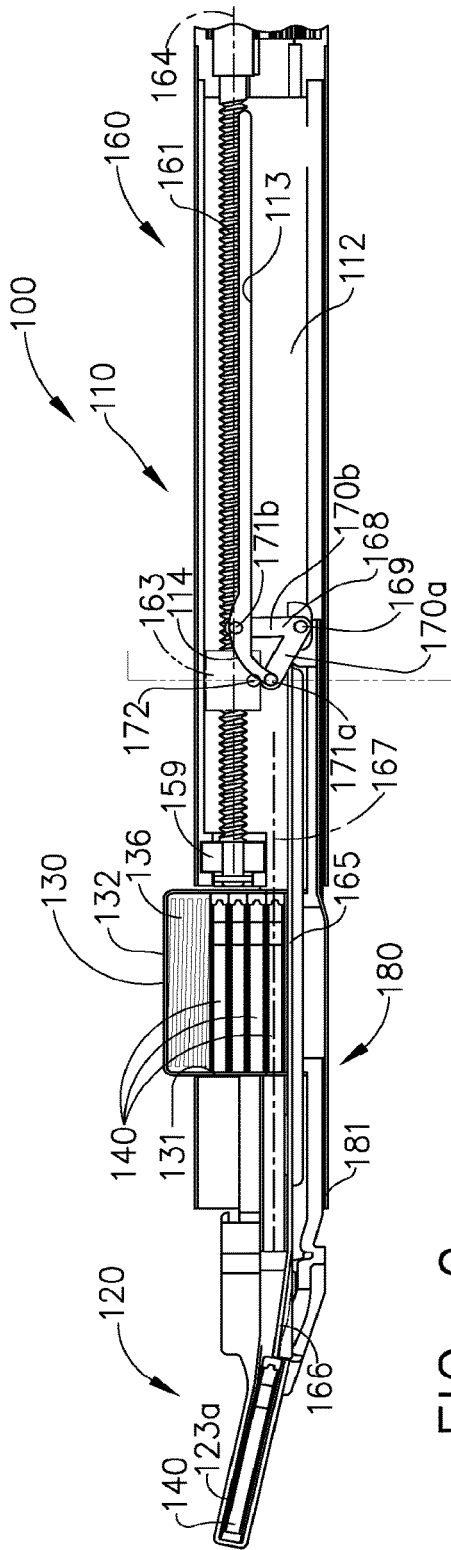

FIG. 9

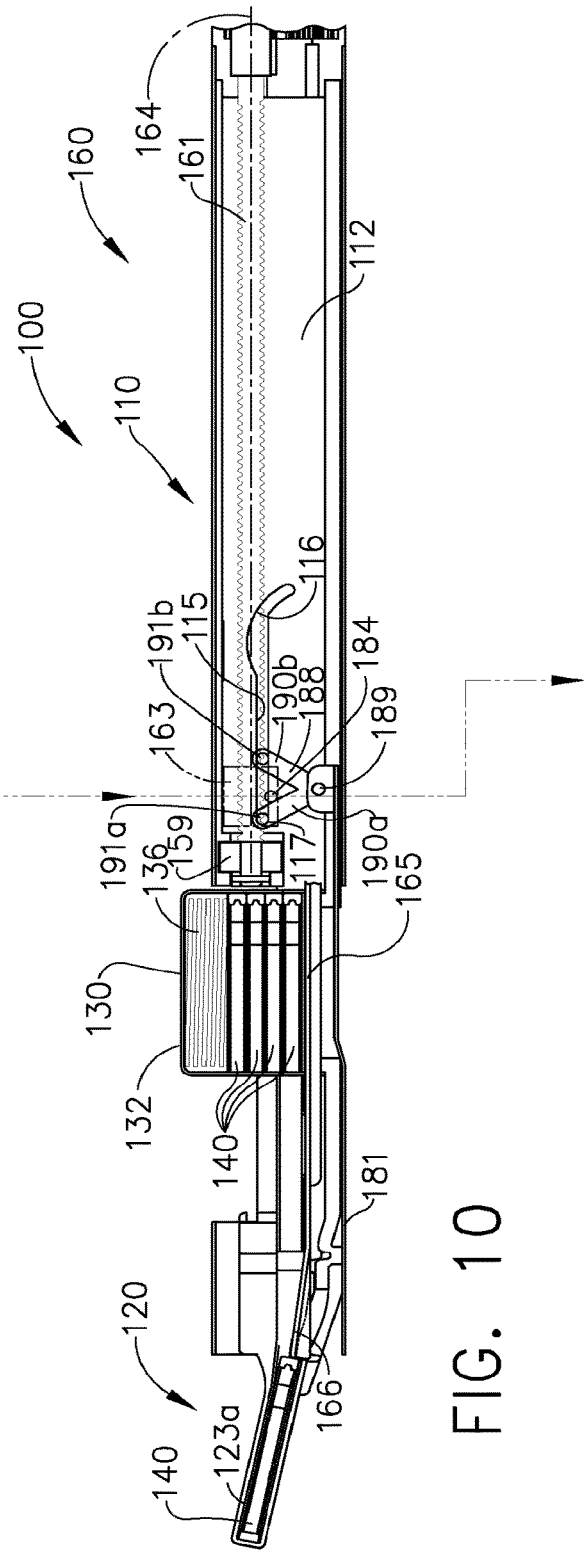
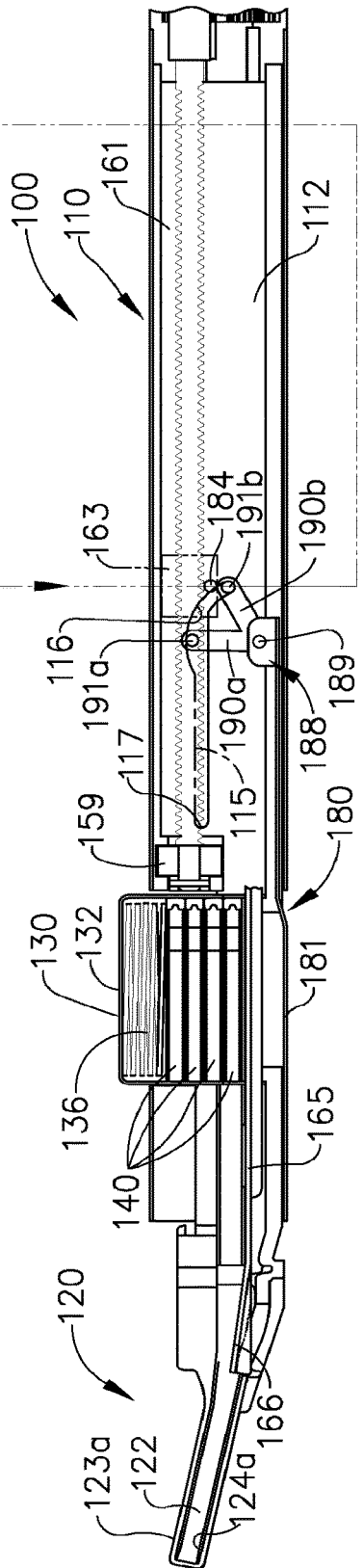
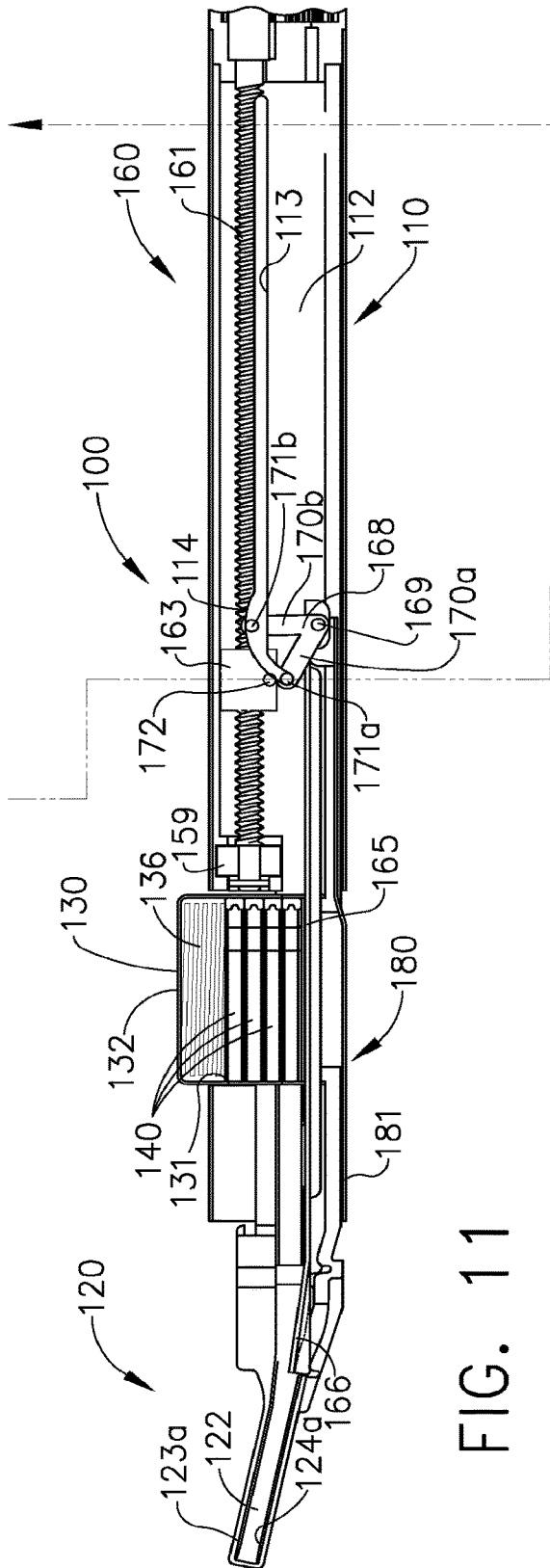

FIG. 10



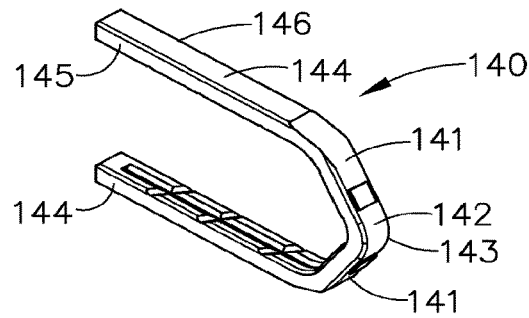

FIG. 13

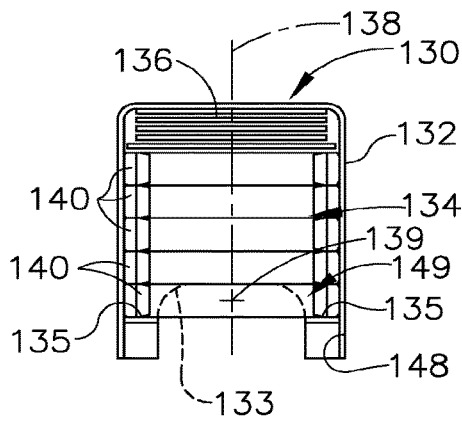

FIG. 14

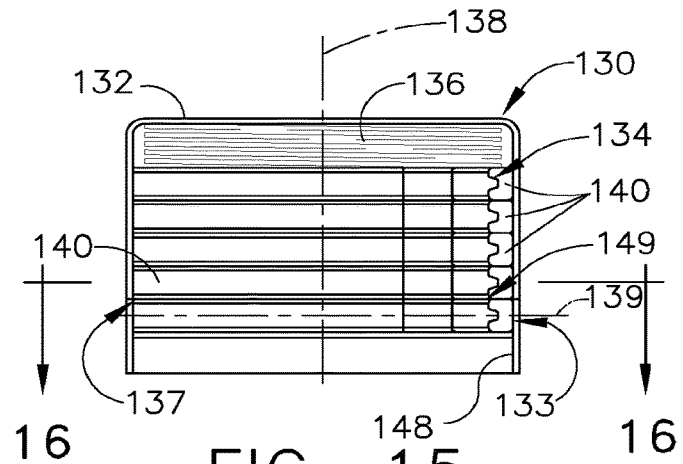

FIG. 15

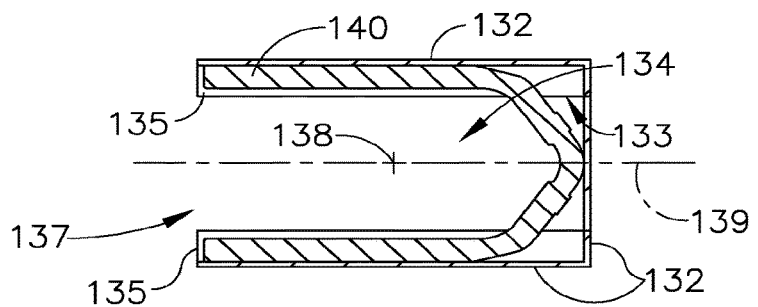

FIG. 16

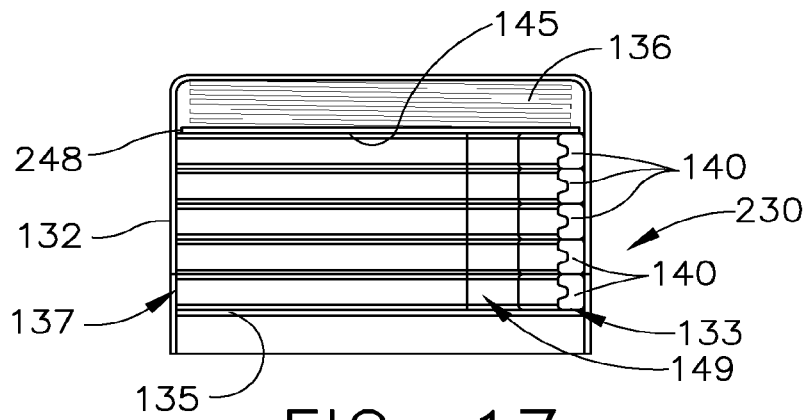

FIG. 17

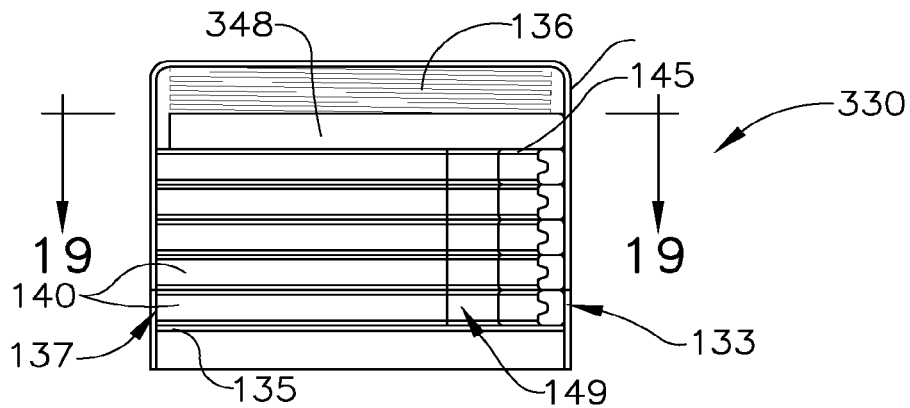

FIG. 18

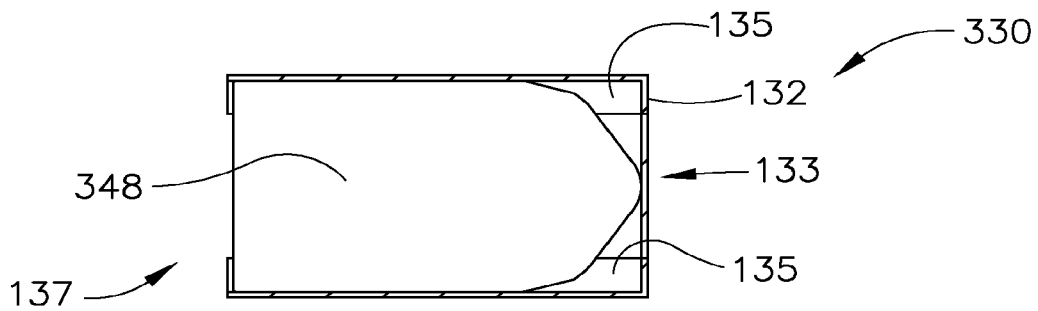

FIG. 19

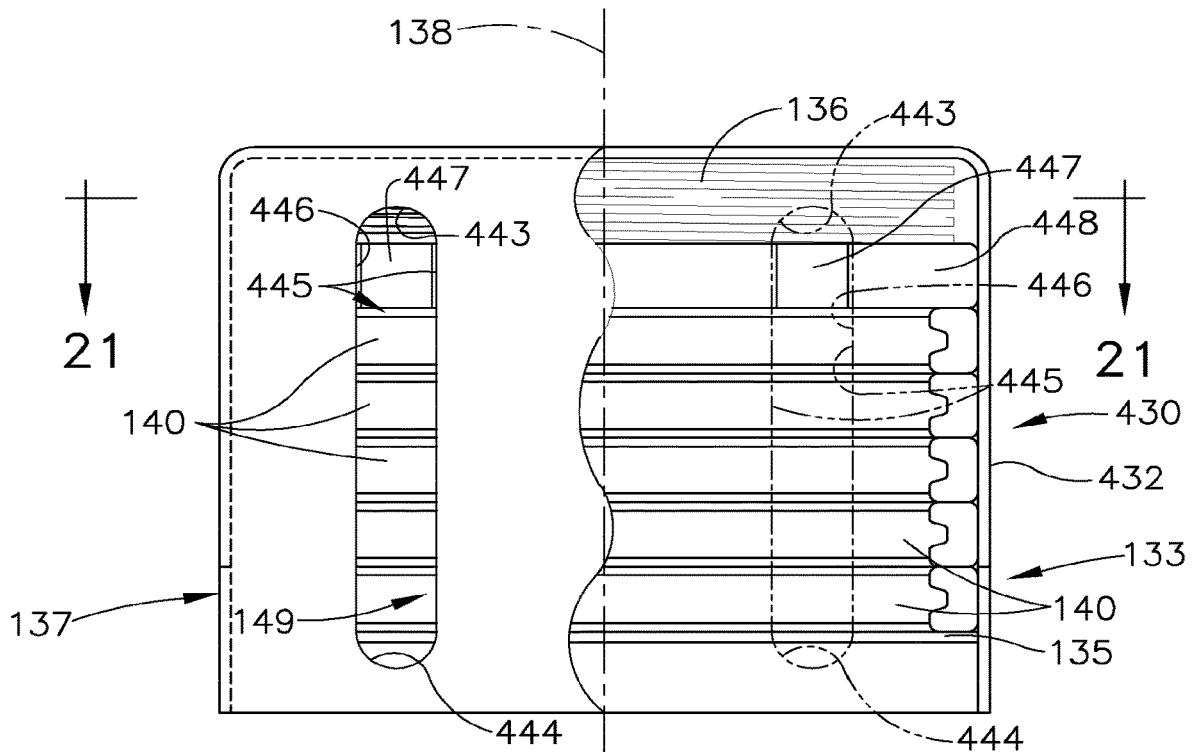

FIG. 20

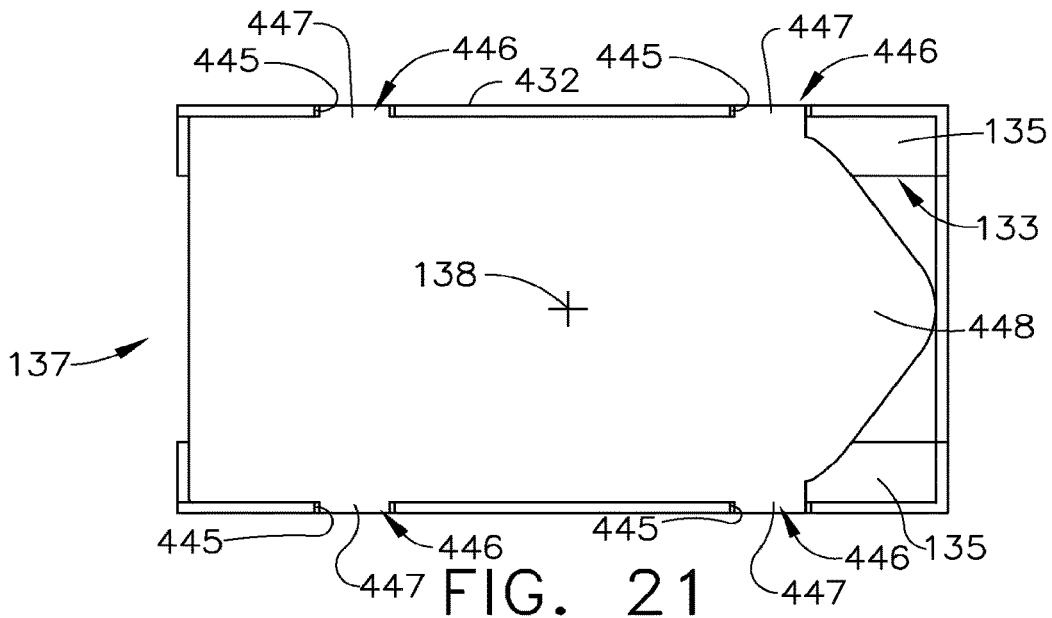

FIG. 21

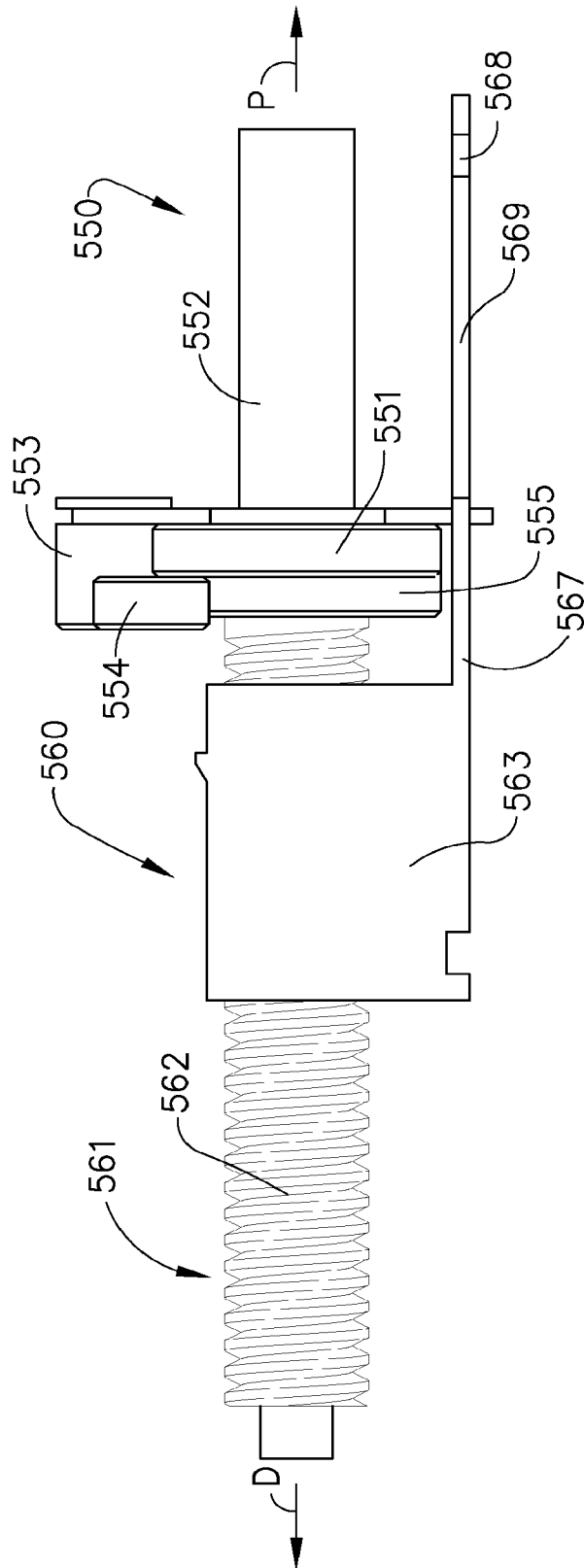

FIG. 22

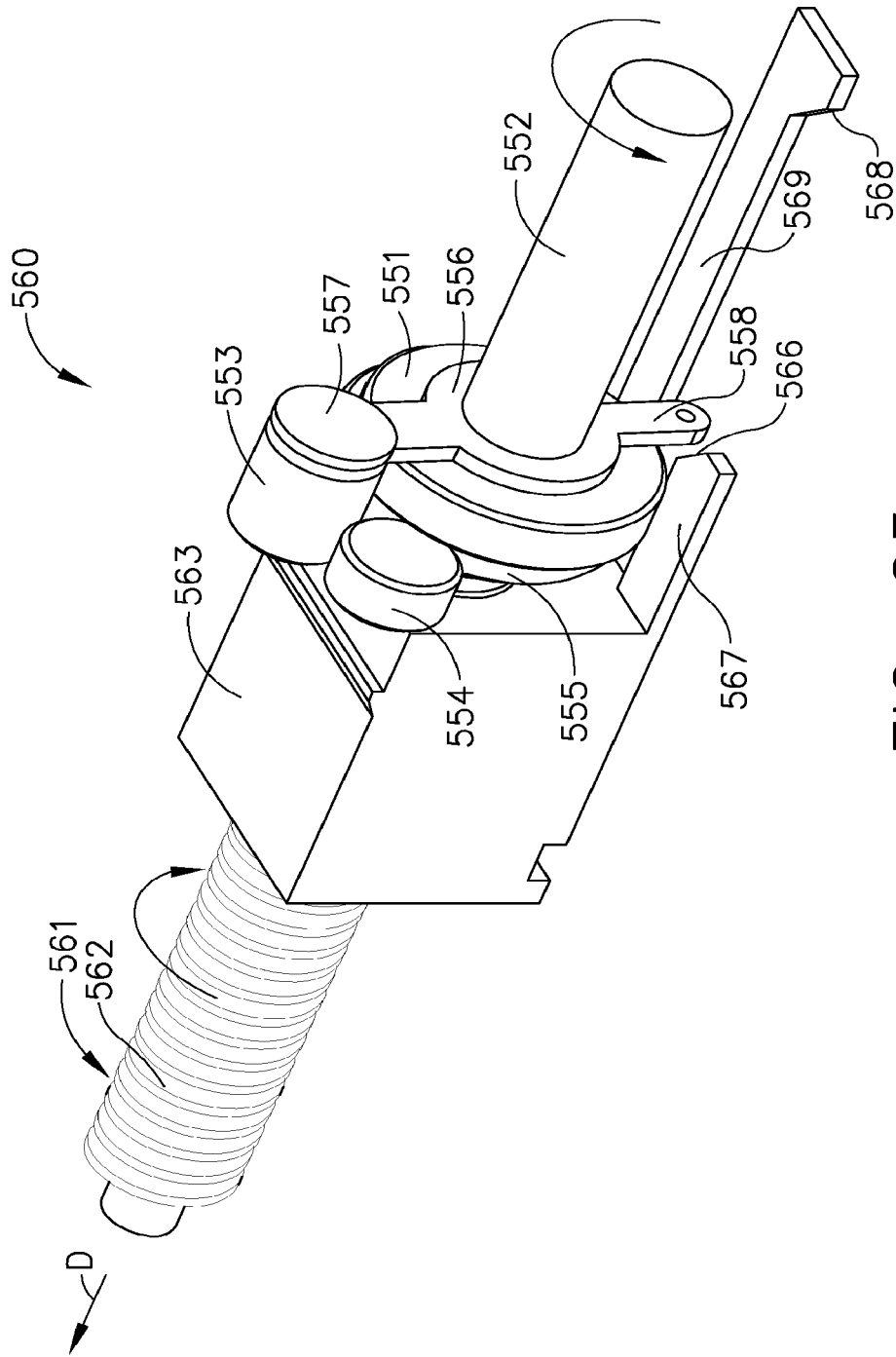

FIG. 23

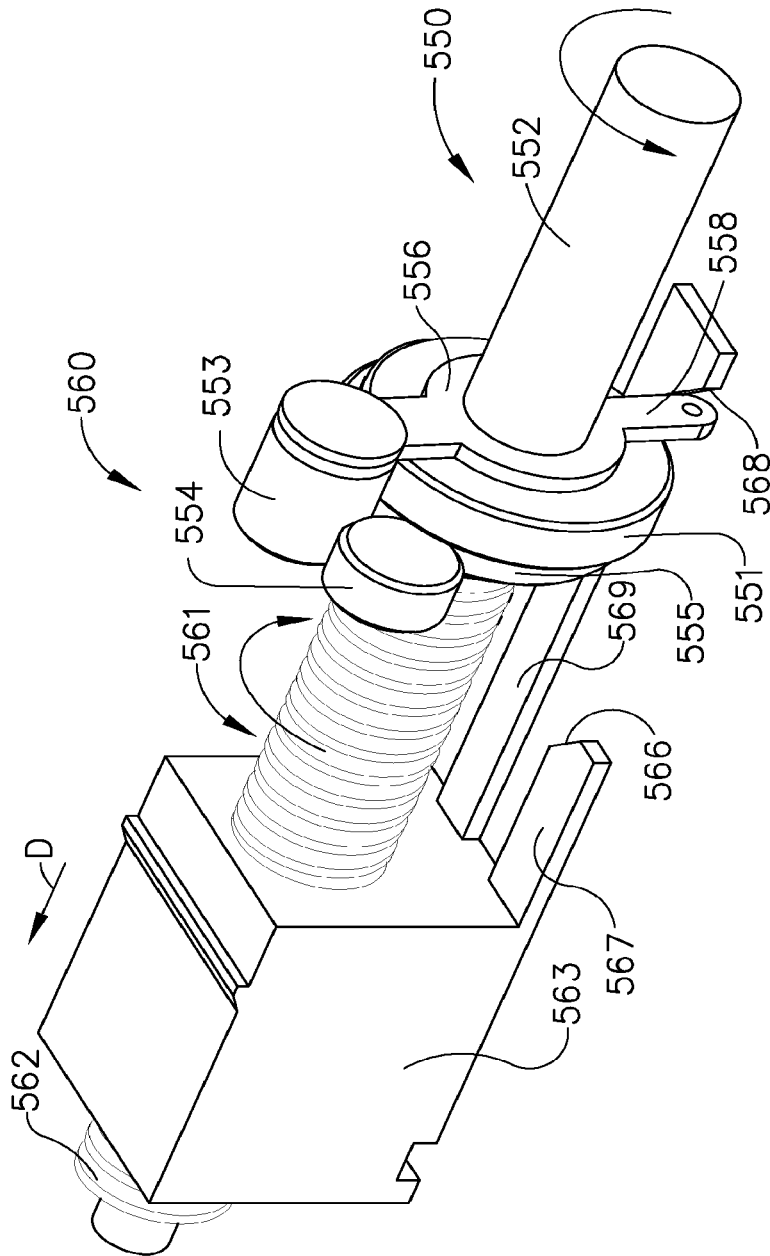

FIG. 24

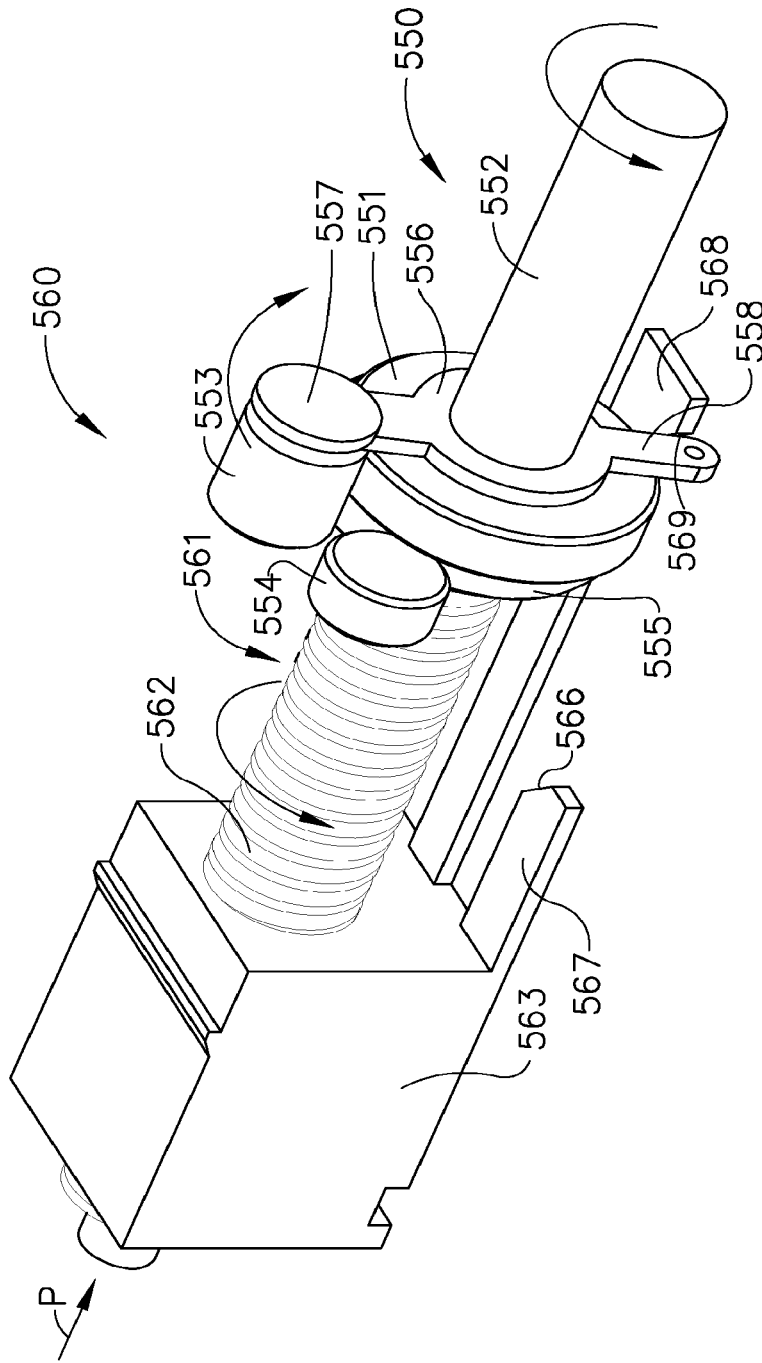

FIG. 25

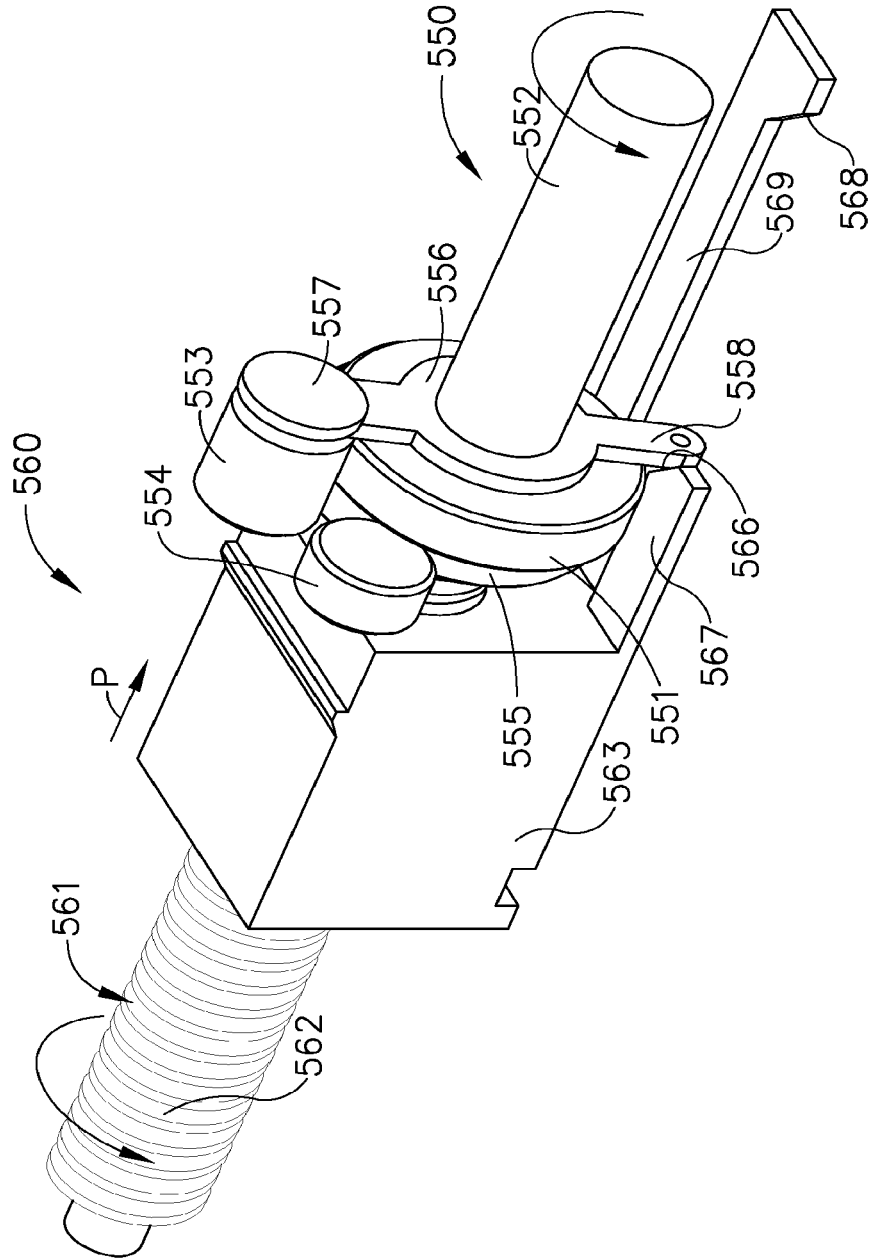

FIG. 26

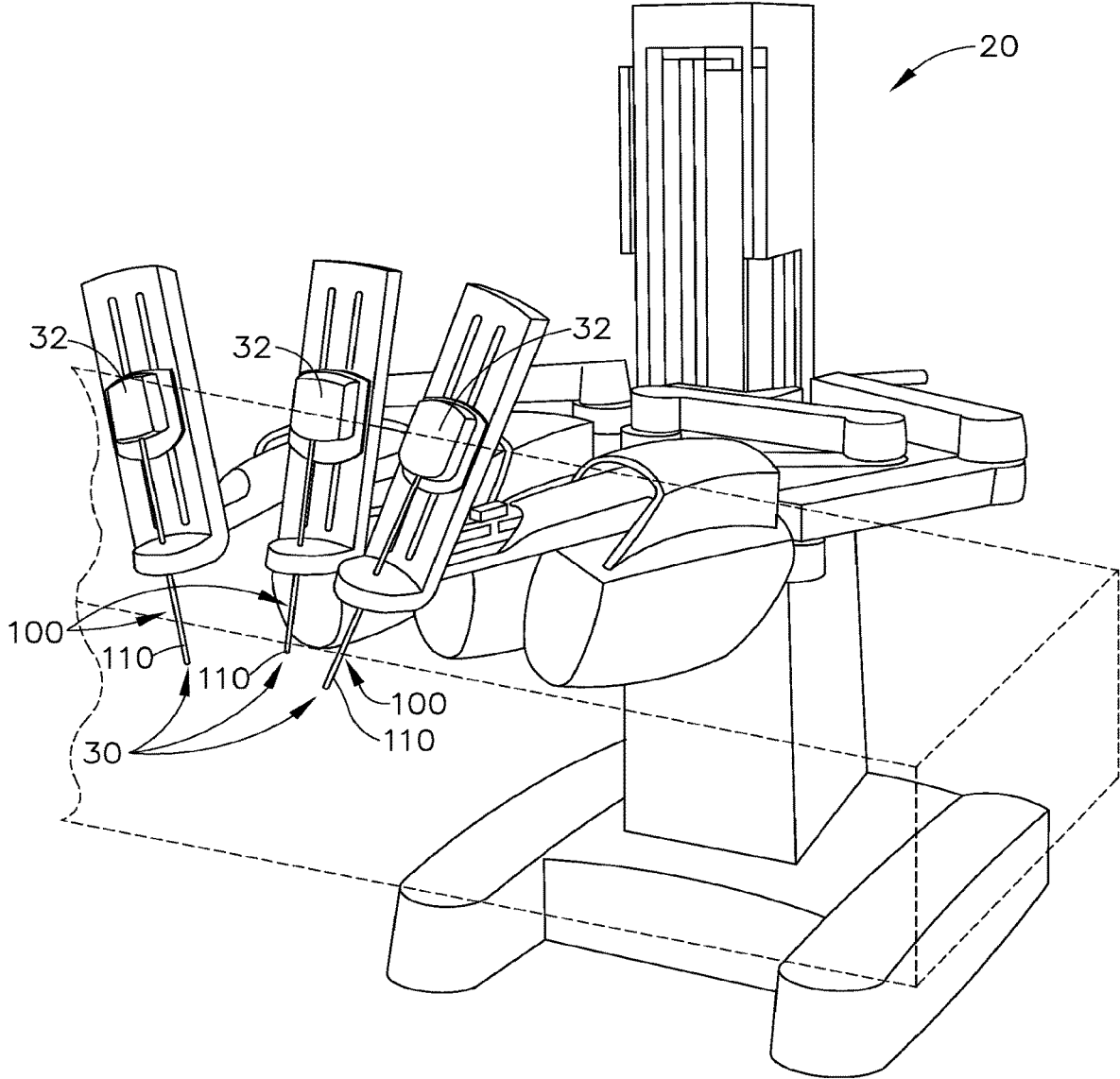

FIG. 27

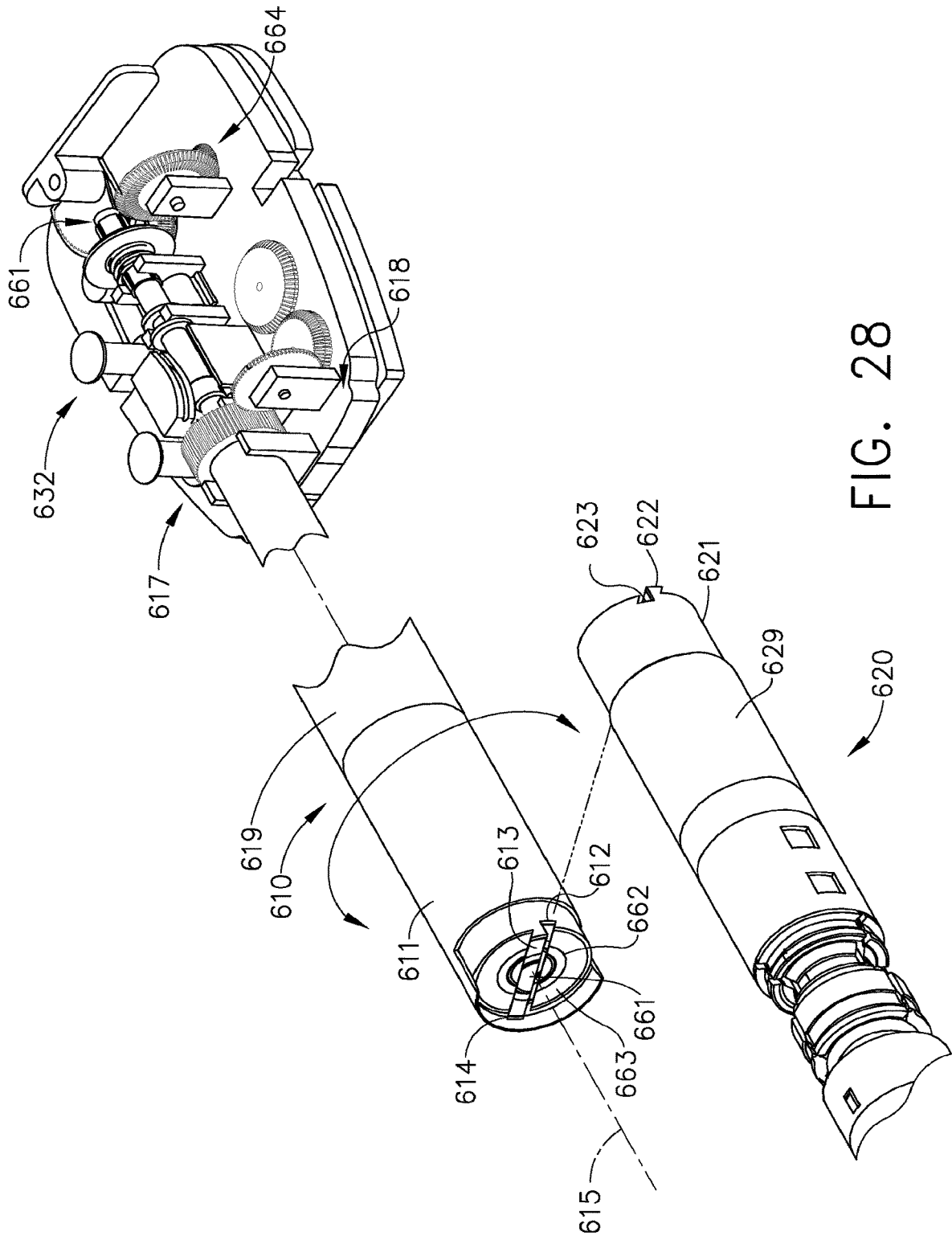

FIG. 28

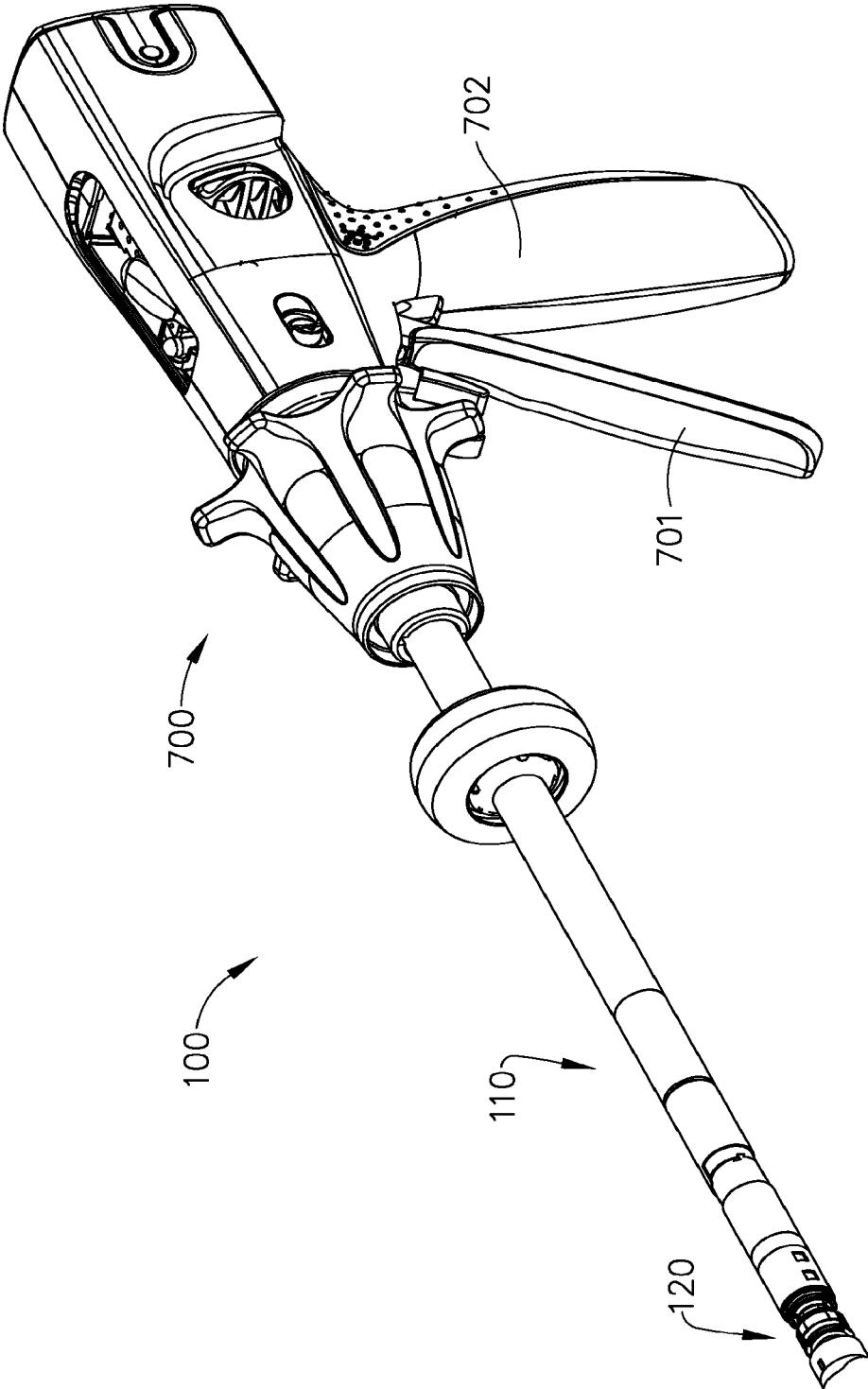

FIG. 29

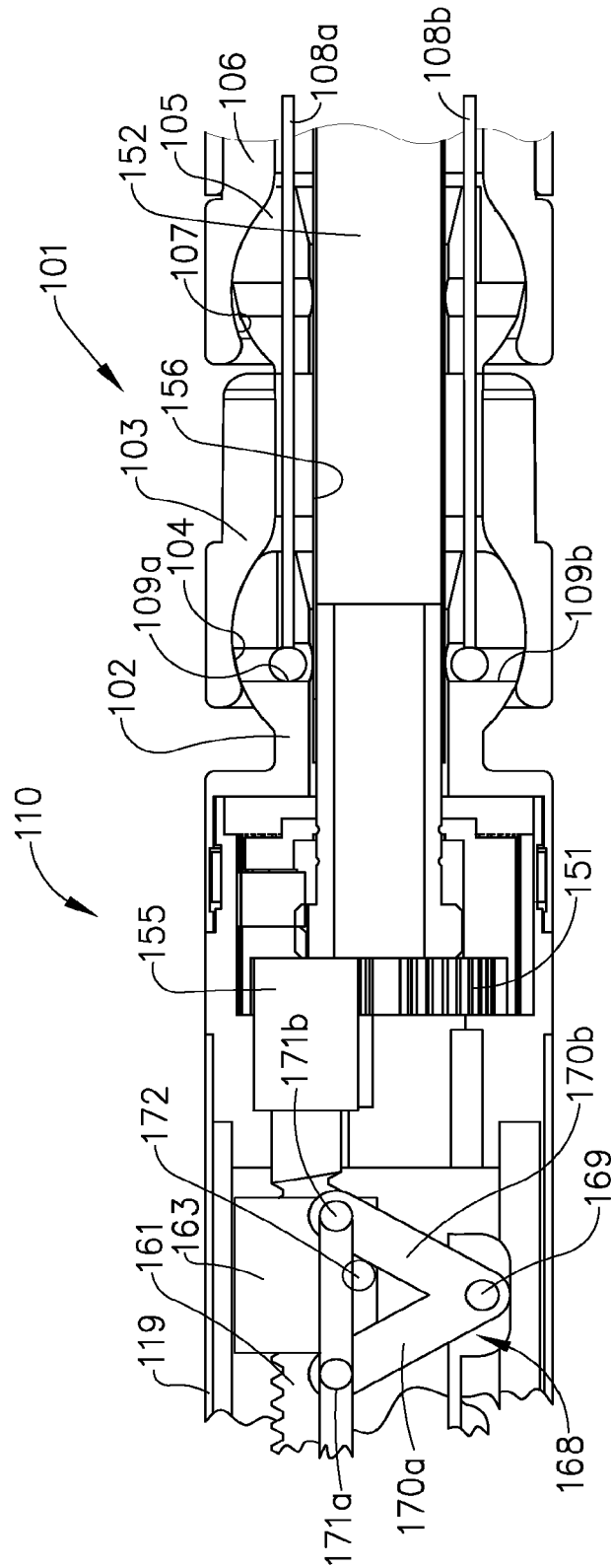

FIG. 30

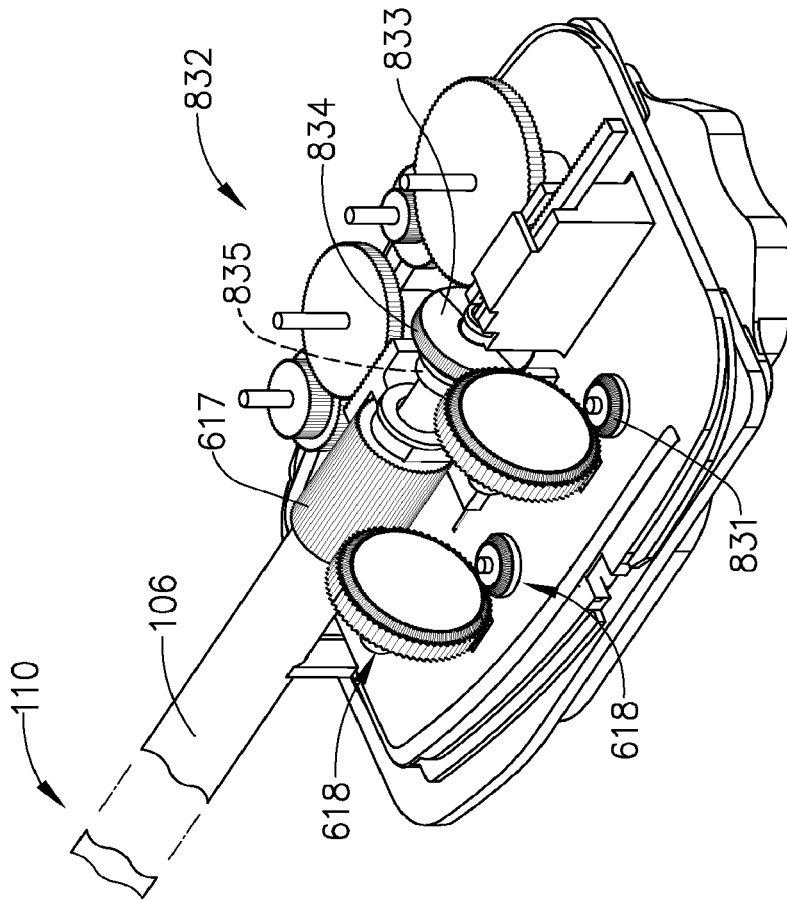

FIG. 31

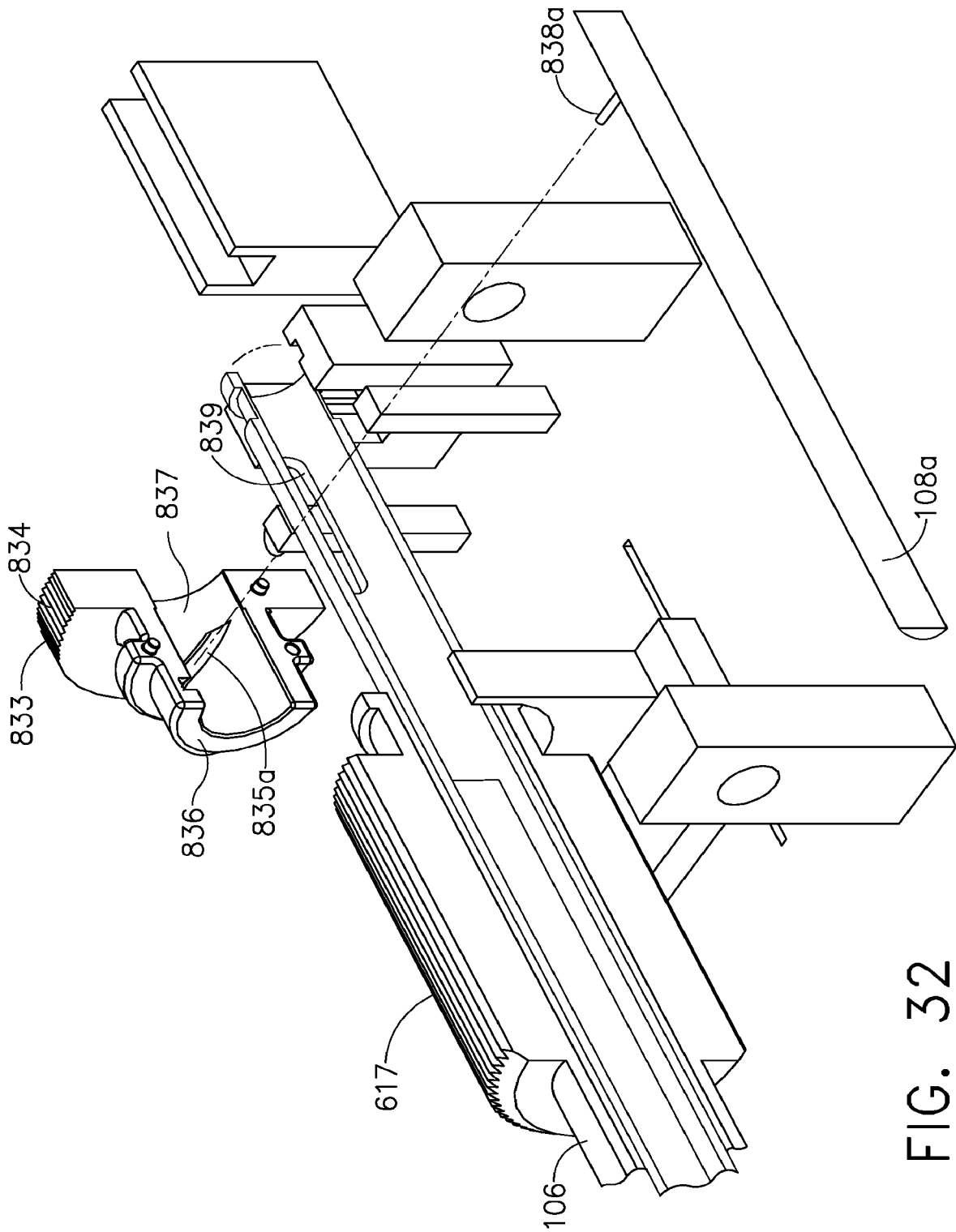

FIG. 32

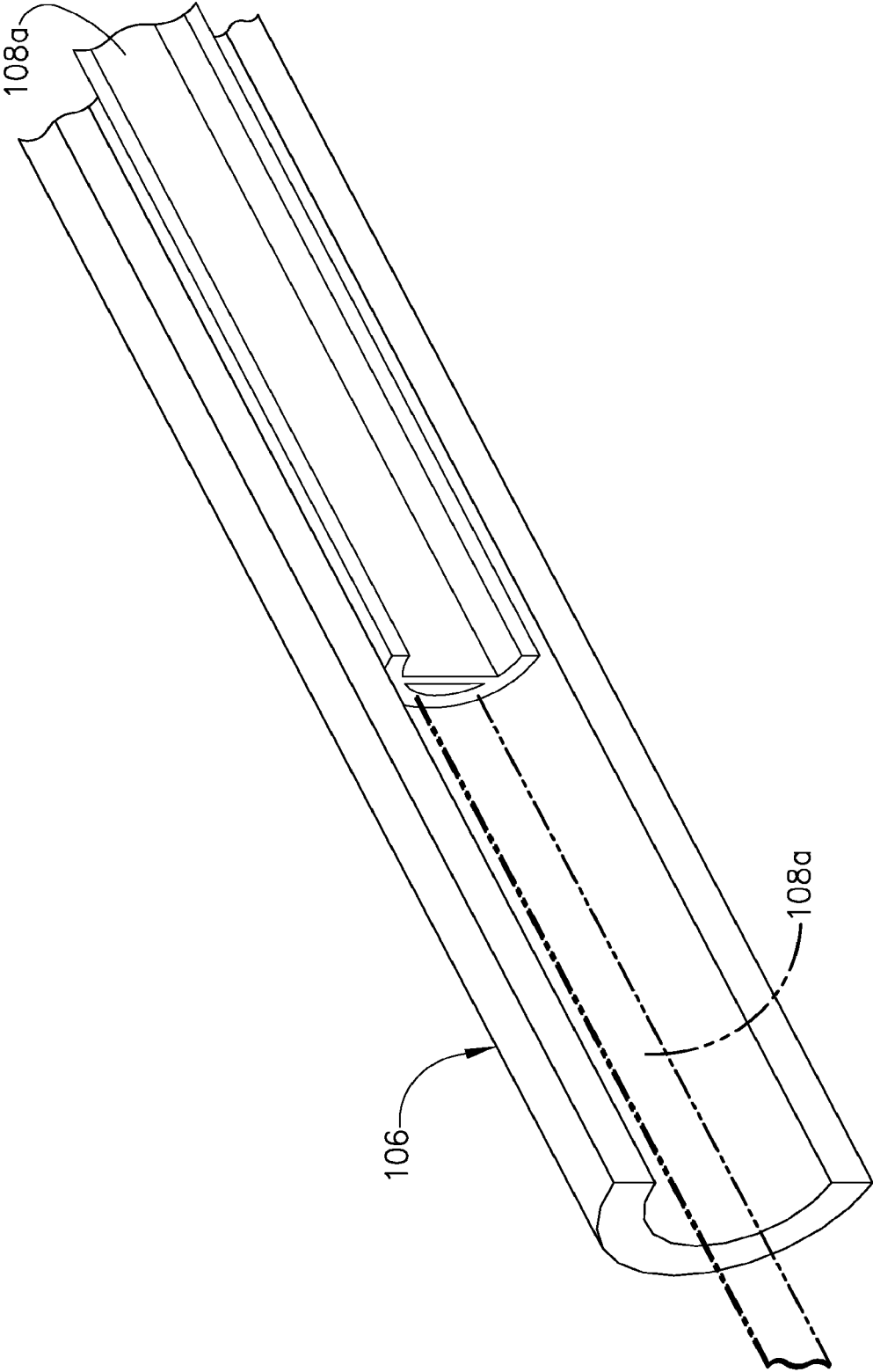

FIG. 33

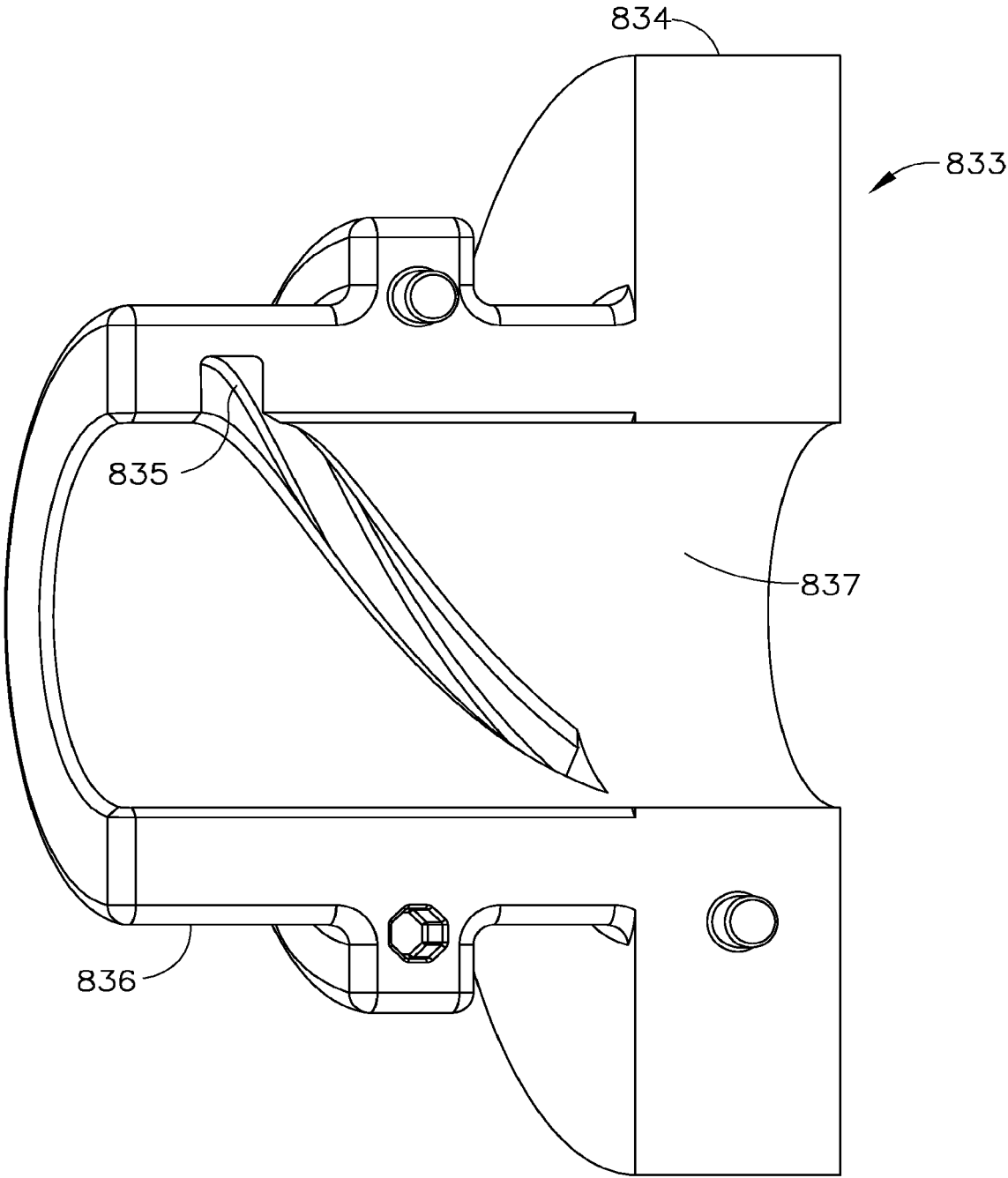

FIG. 34

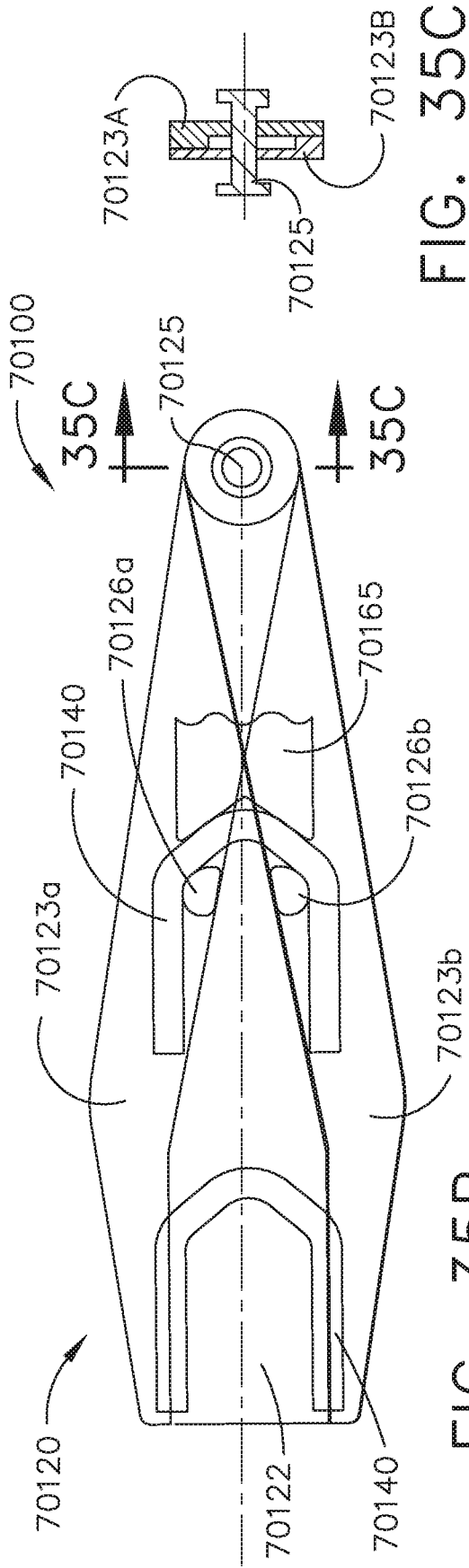

FIG. 35B

FIG. 35C

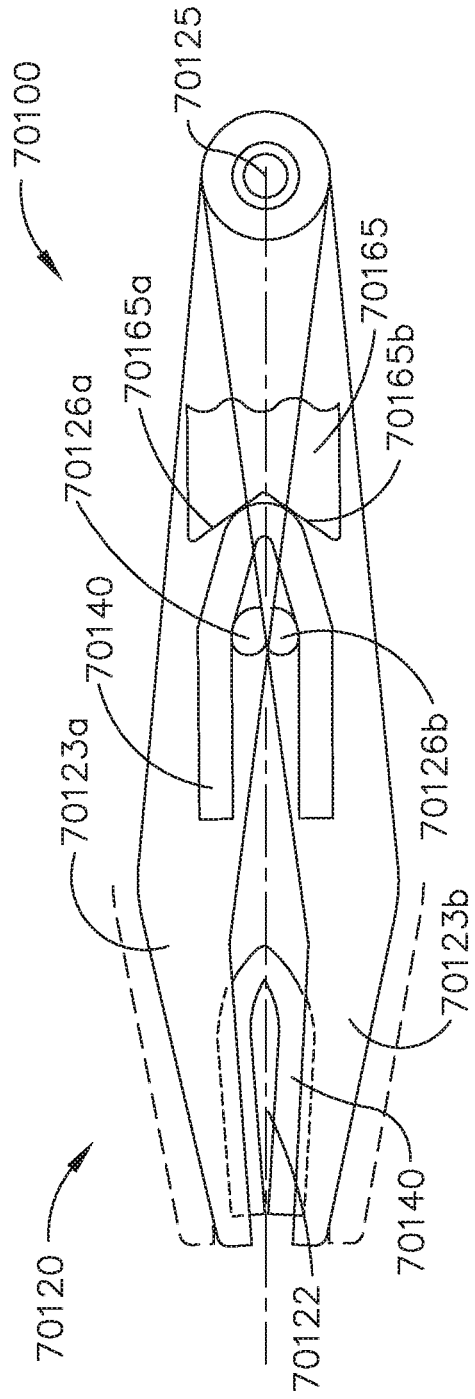
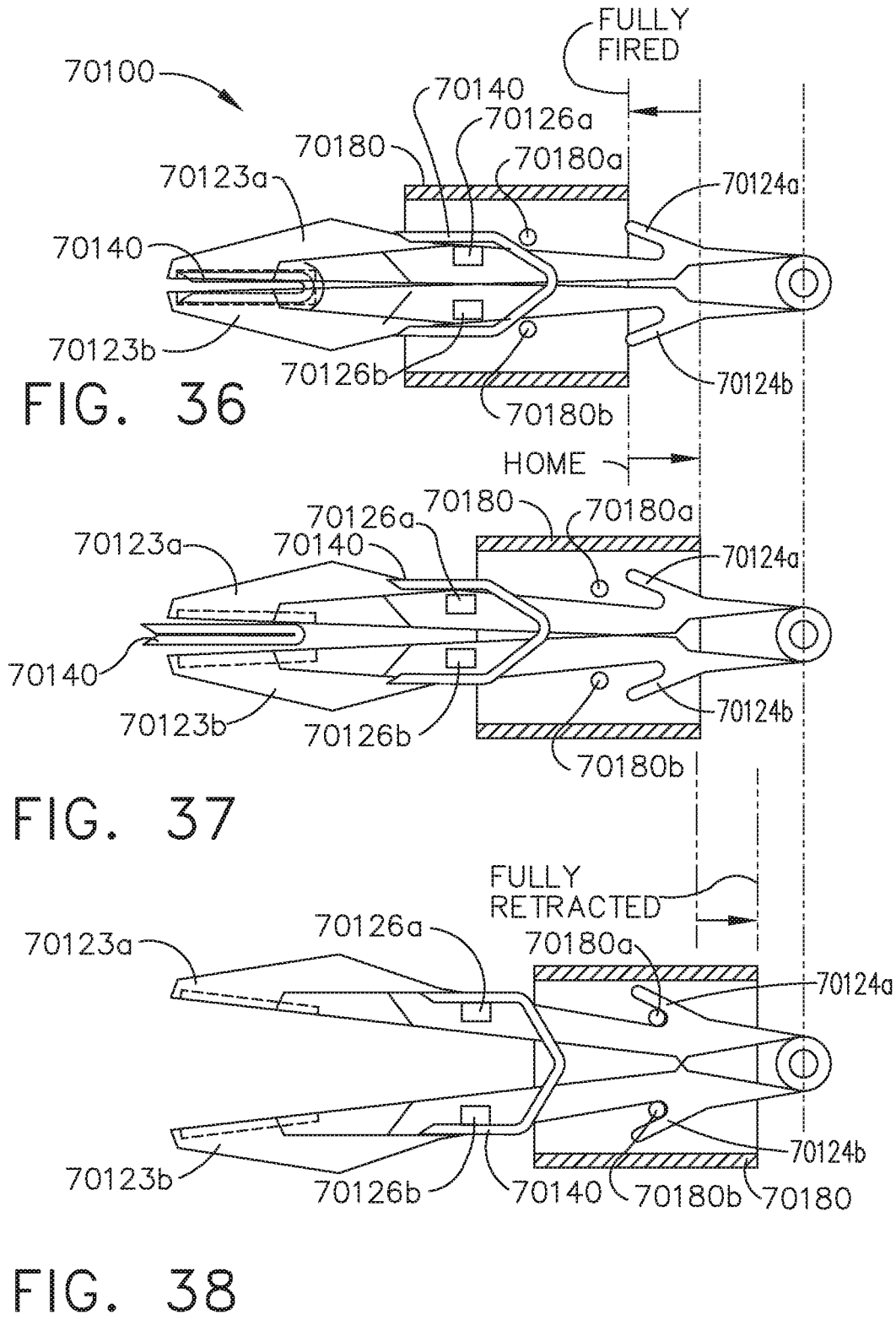

FIG. 35A



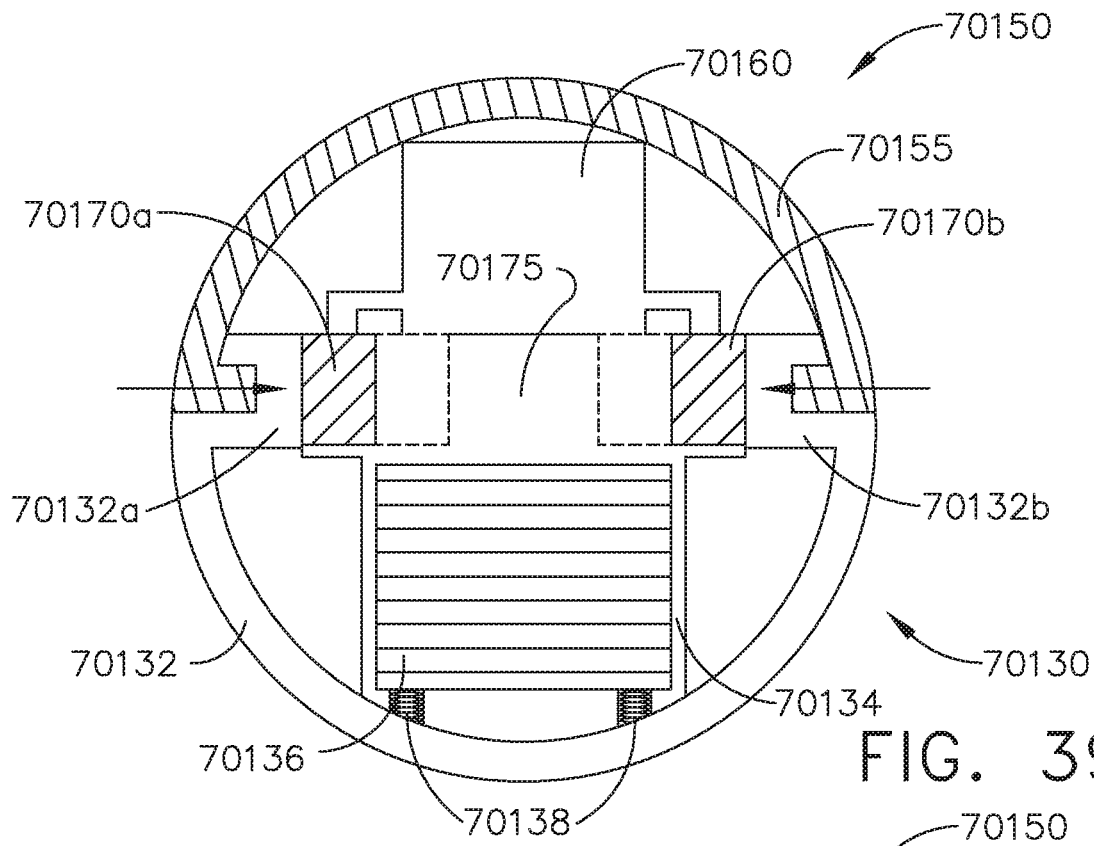

FIG. 39

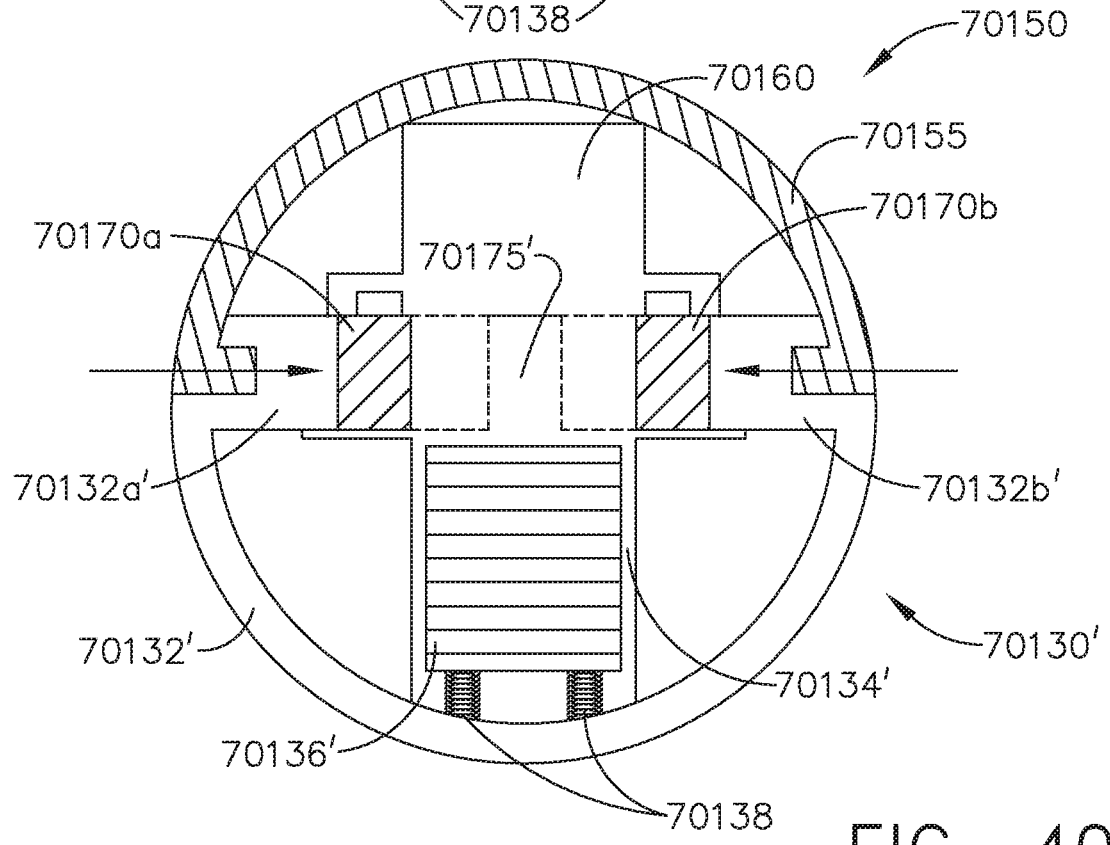

FIG. 40

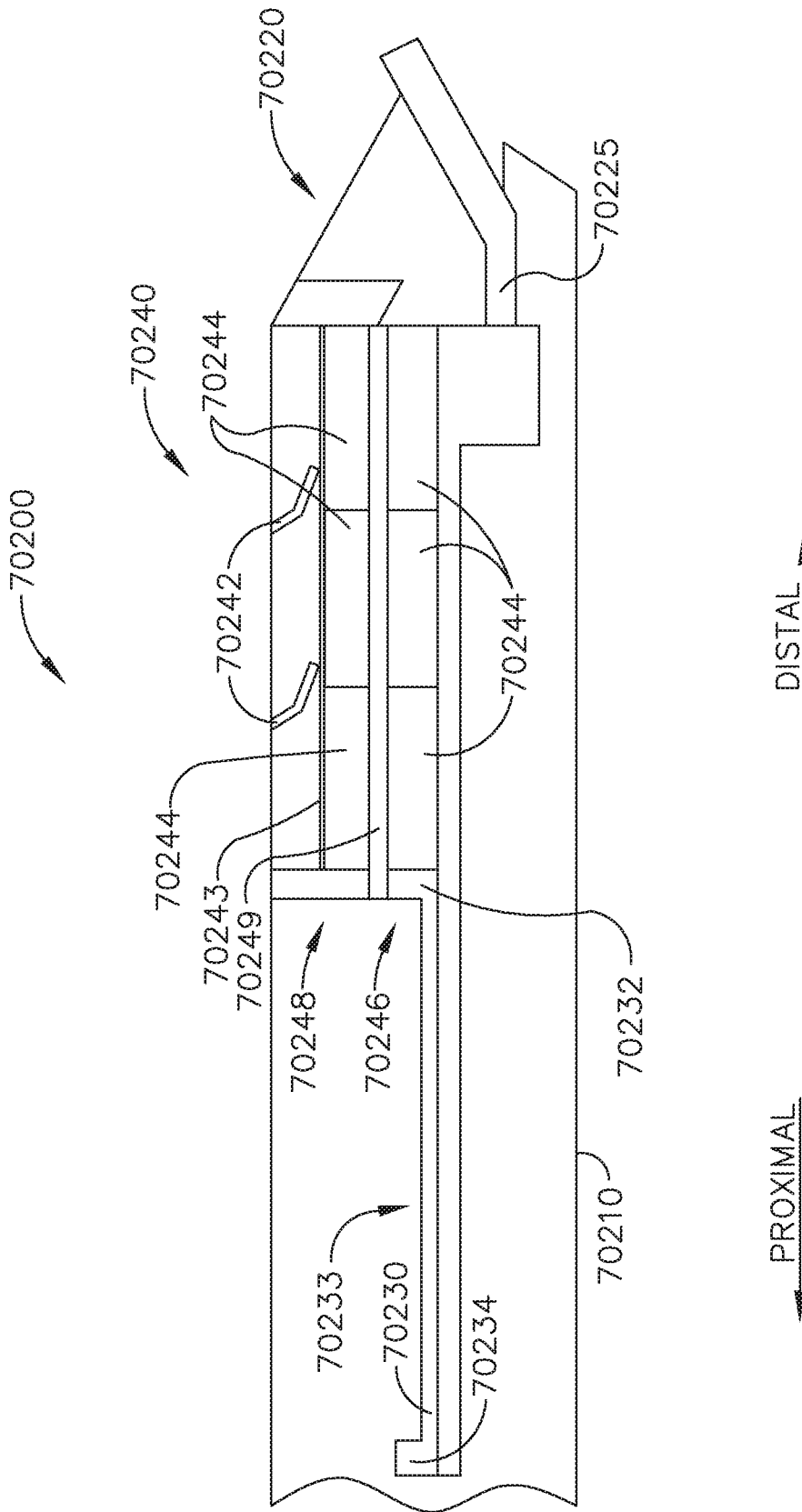

FIG. 41

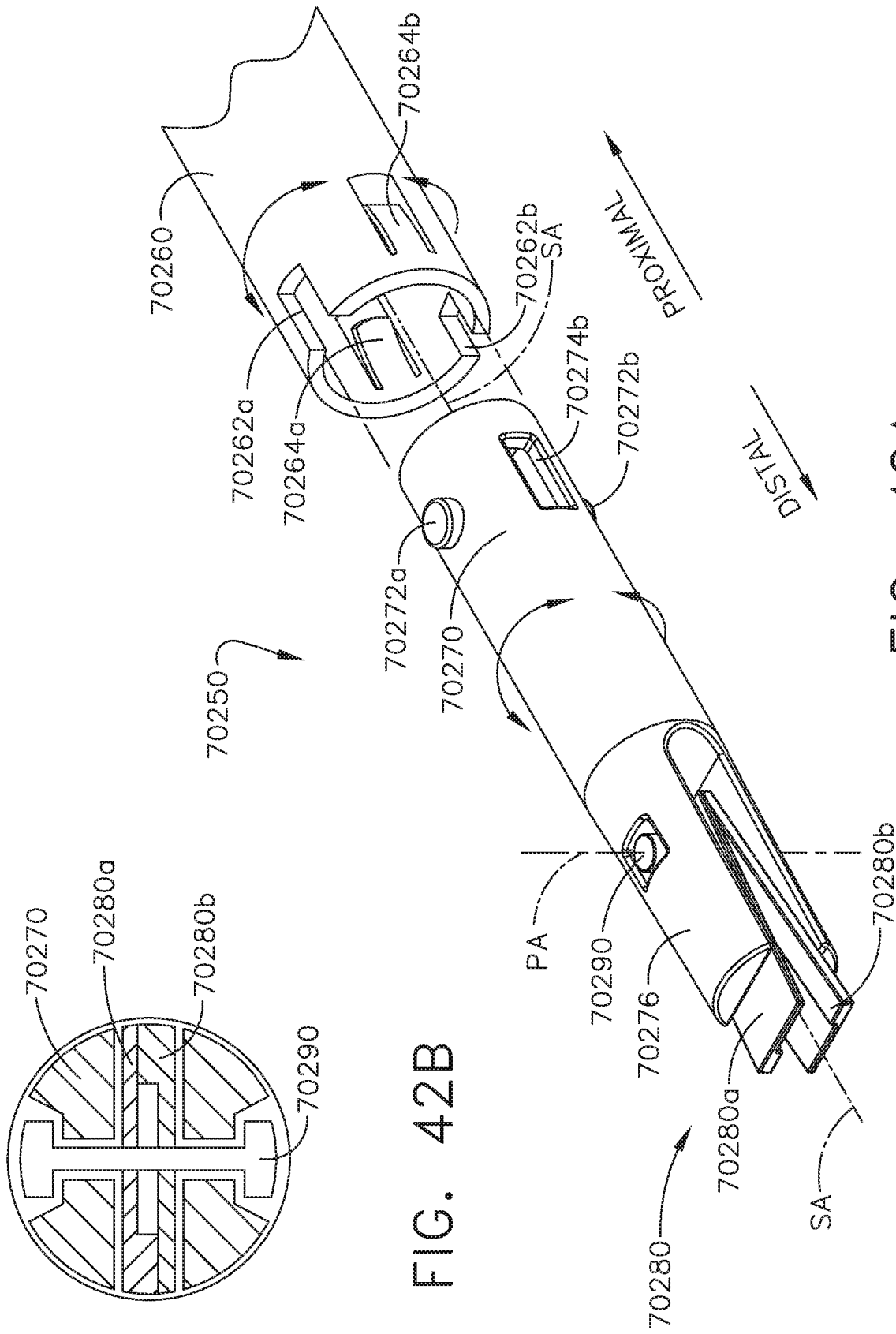

FIG. 42B

FIG. 42A

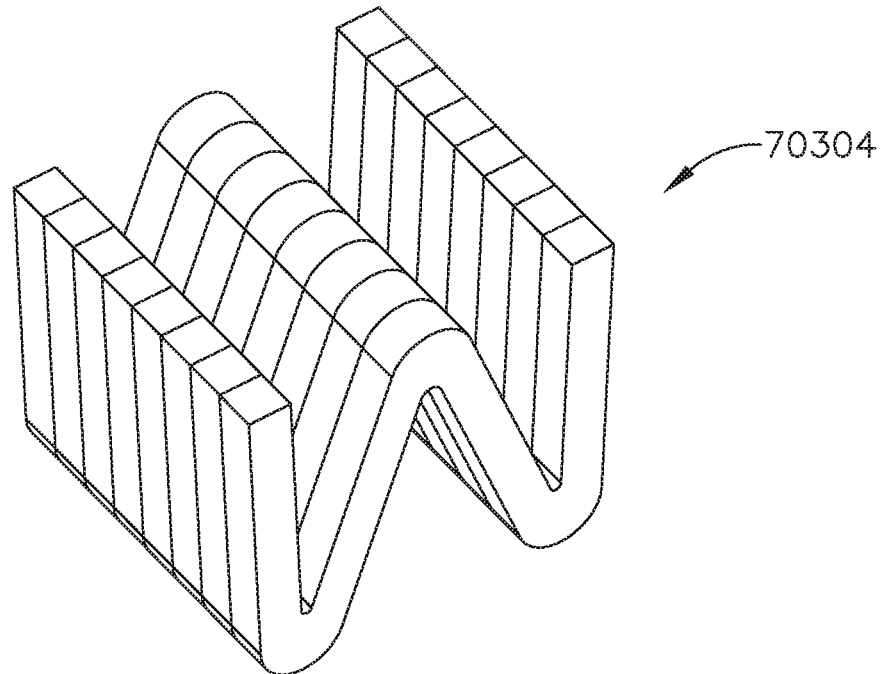

FIG. 43B

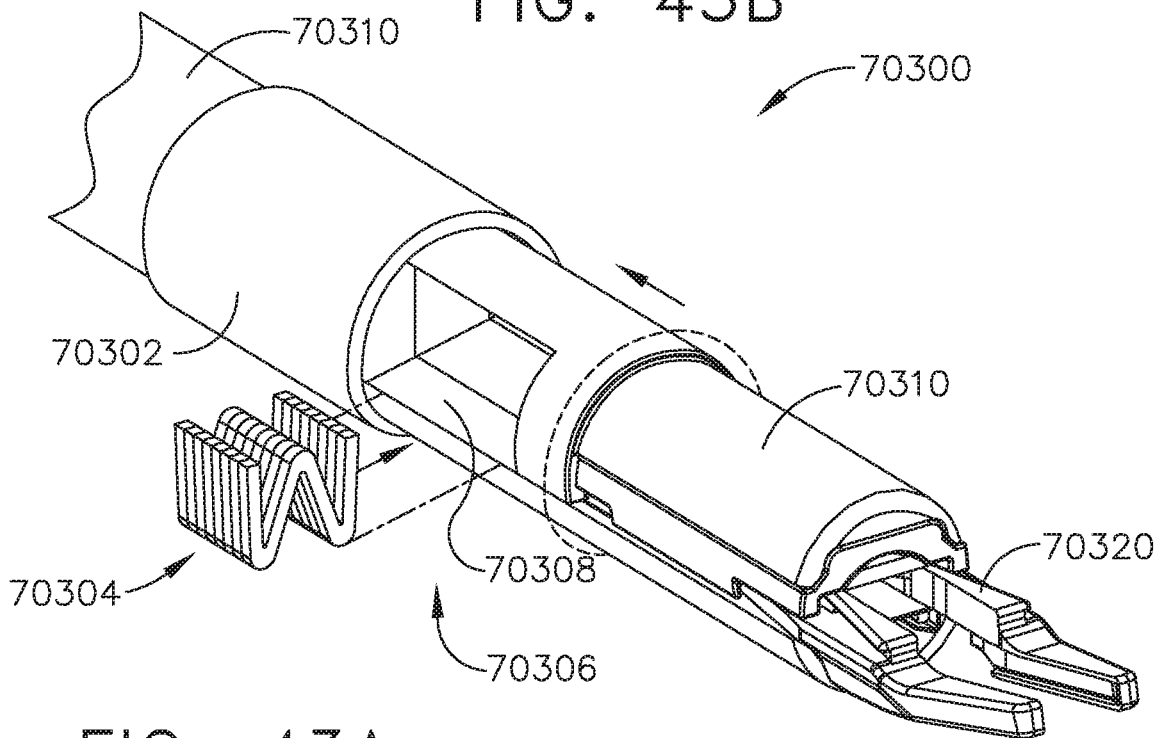

FIG. 43A

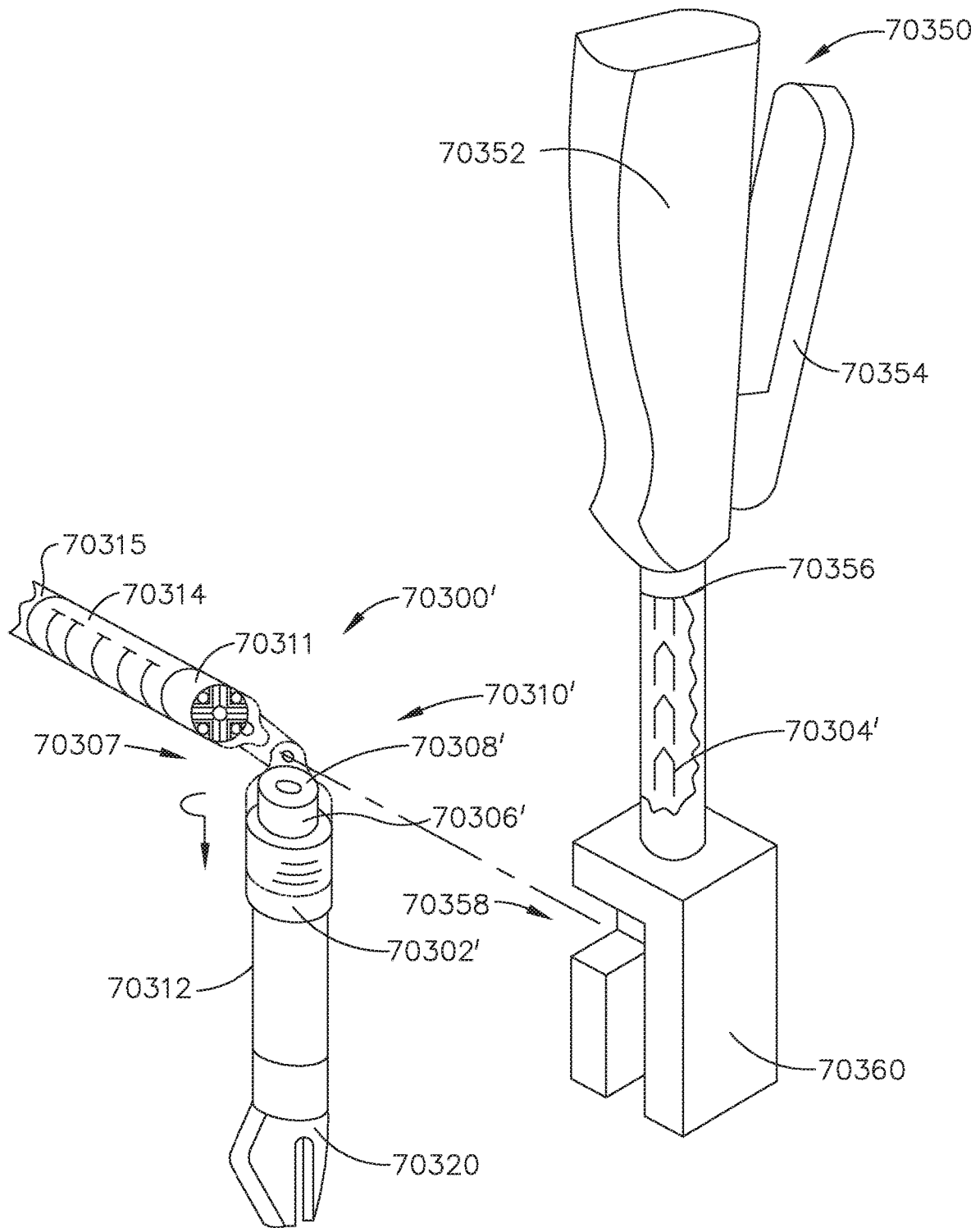

FIG. 44

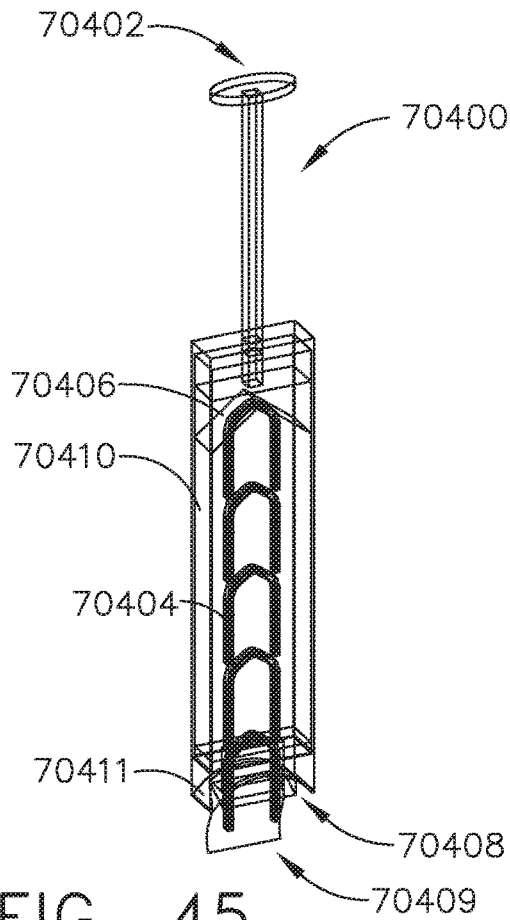

FIG. 45

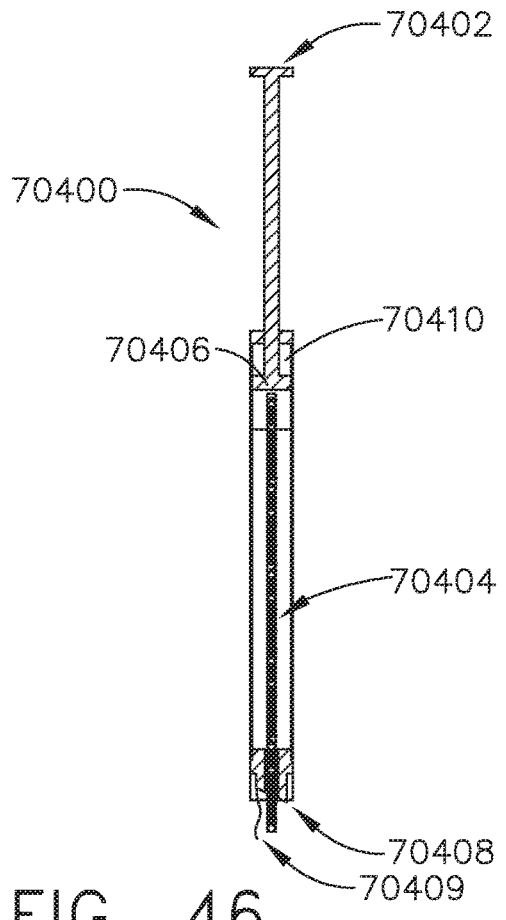

FIG. 46

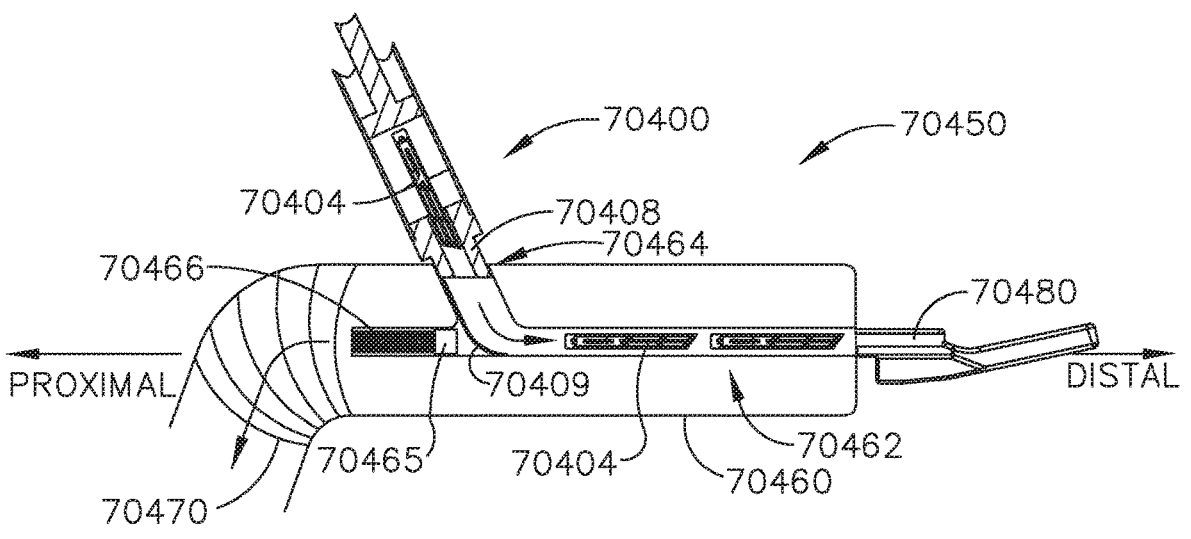

FIG. 47

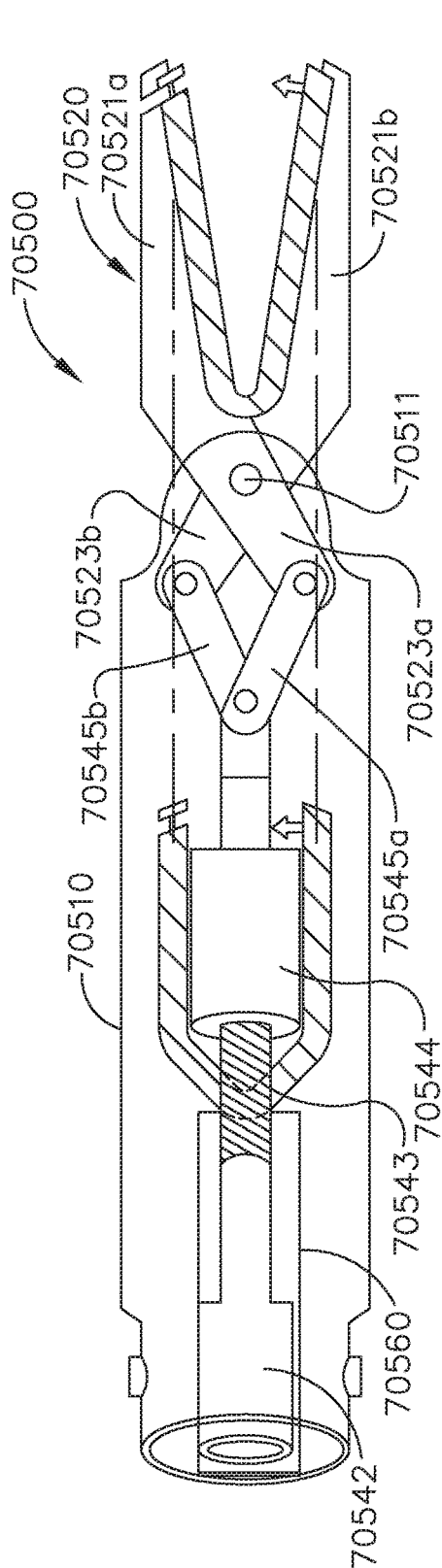

FIG. 48

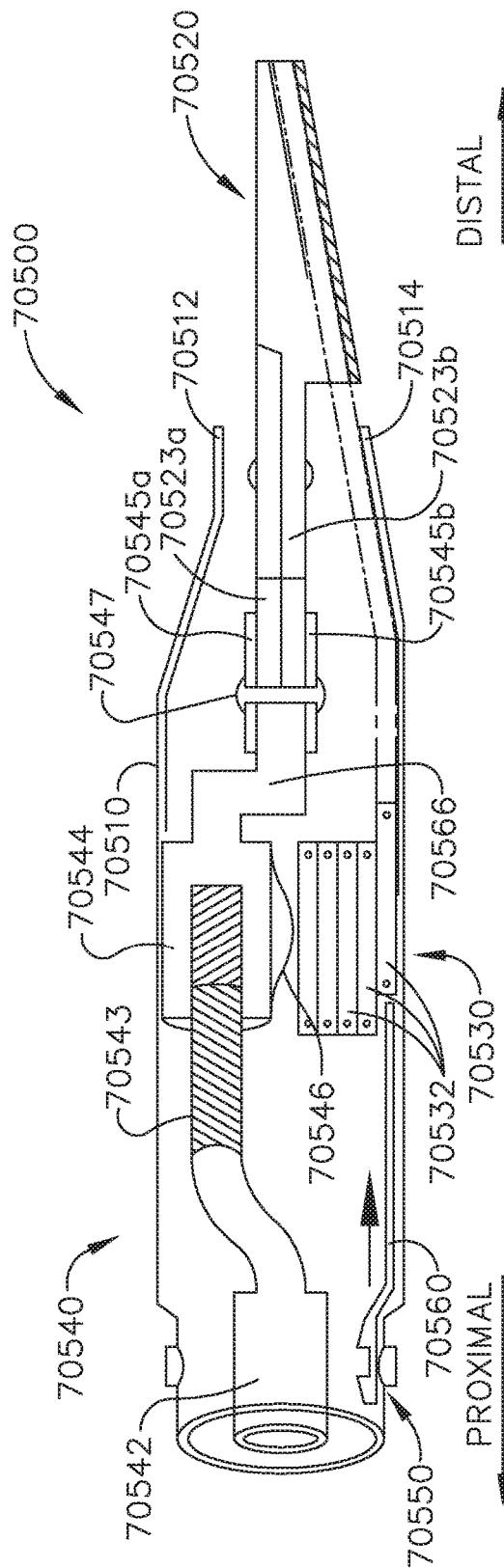

FIG. 49

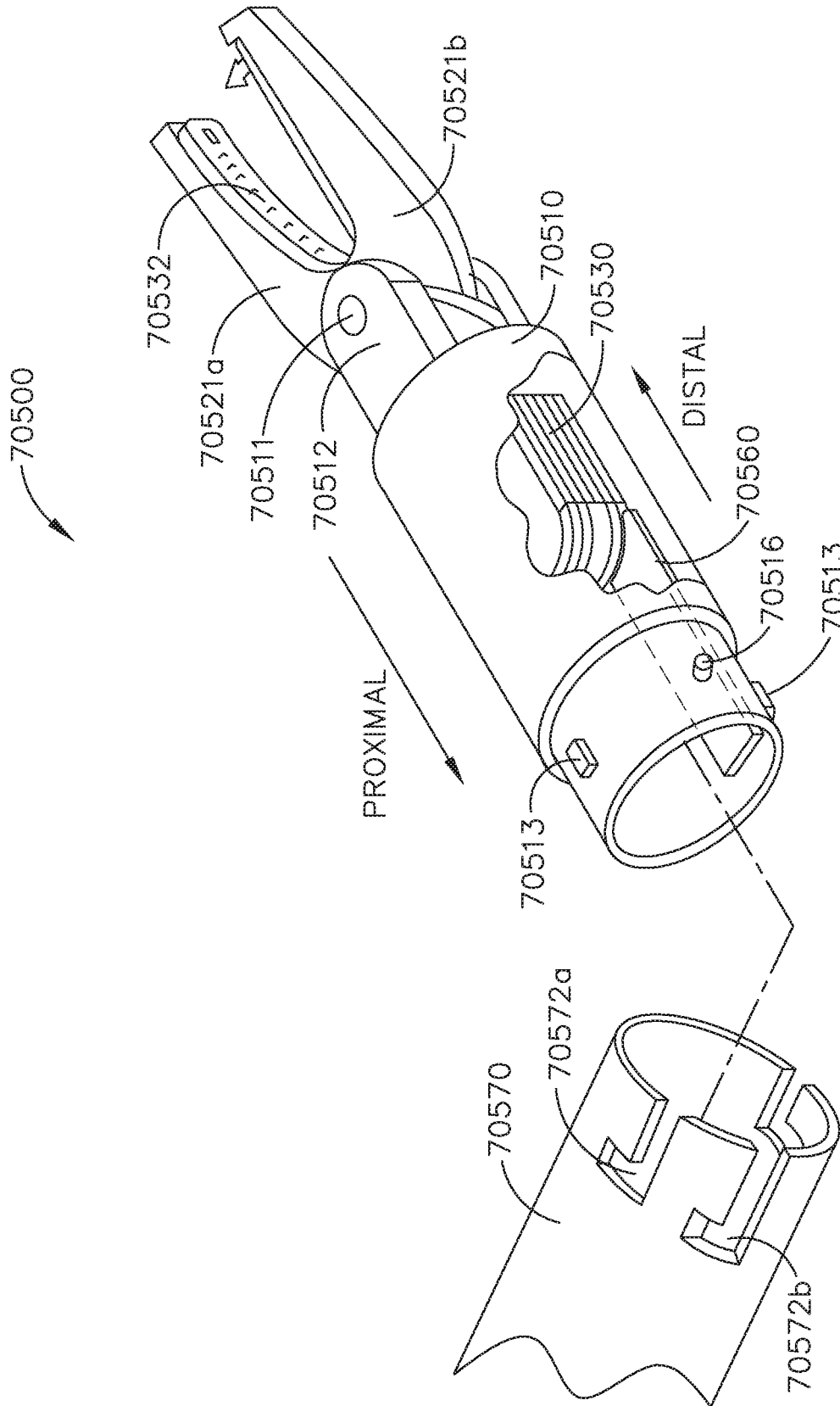

FIG. 50

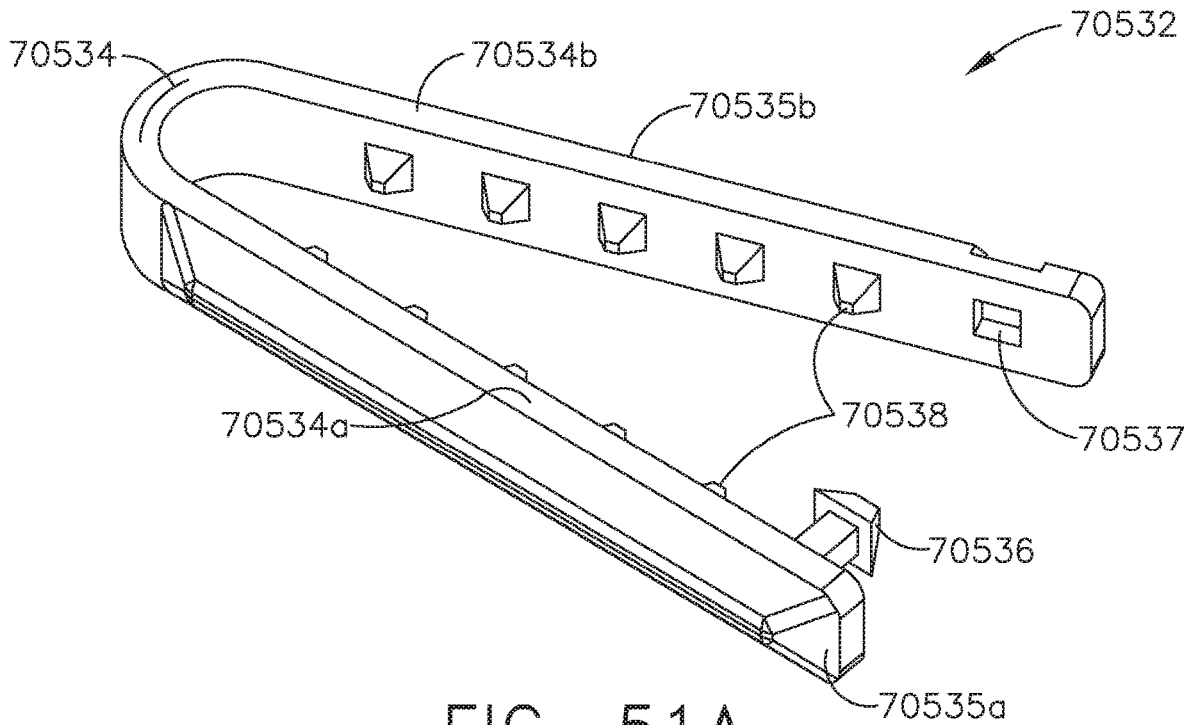

FIG. 51A

MAGAZINE
STORAGE

PRE-
FIRING

POST-
FIRING

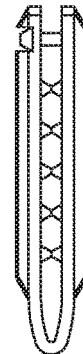
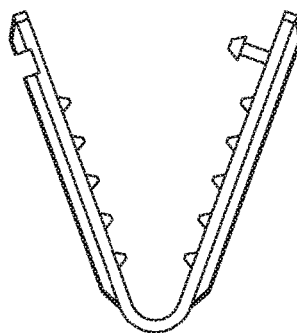
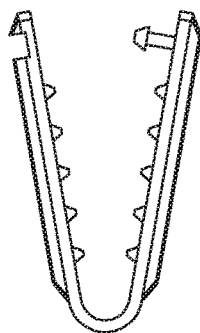

FIG. 51B

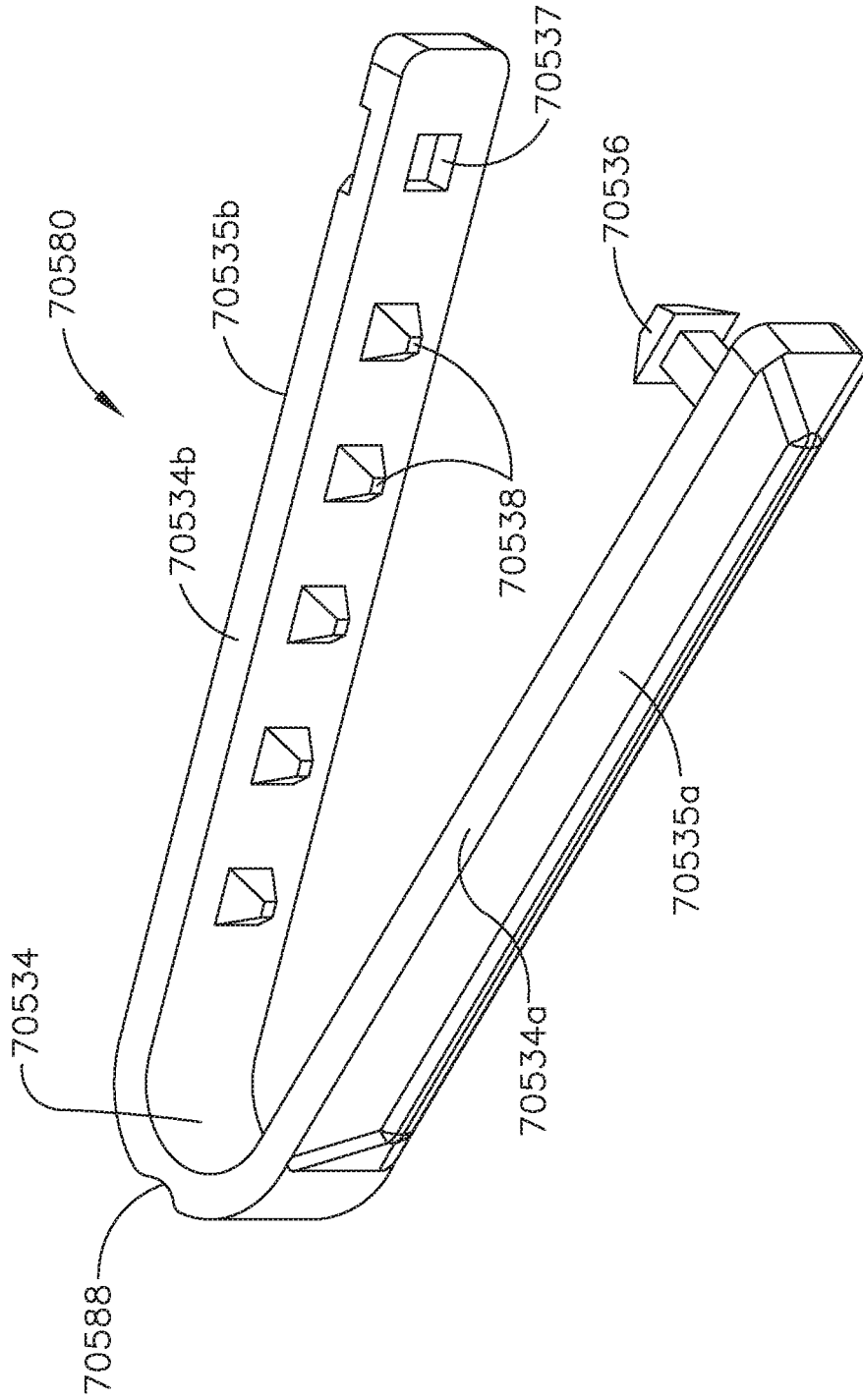

FIG. 51C

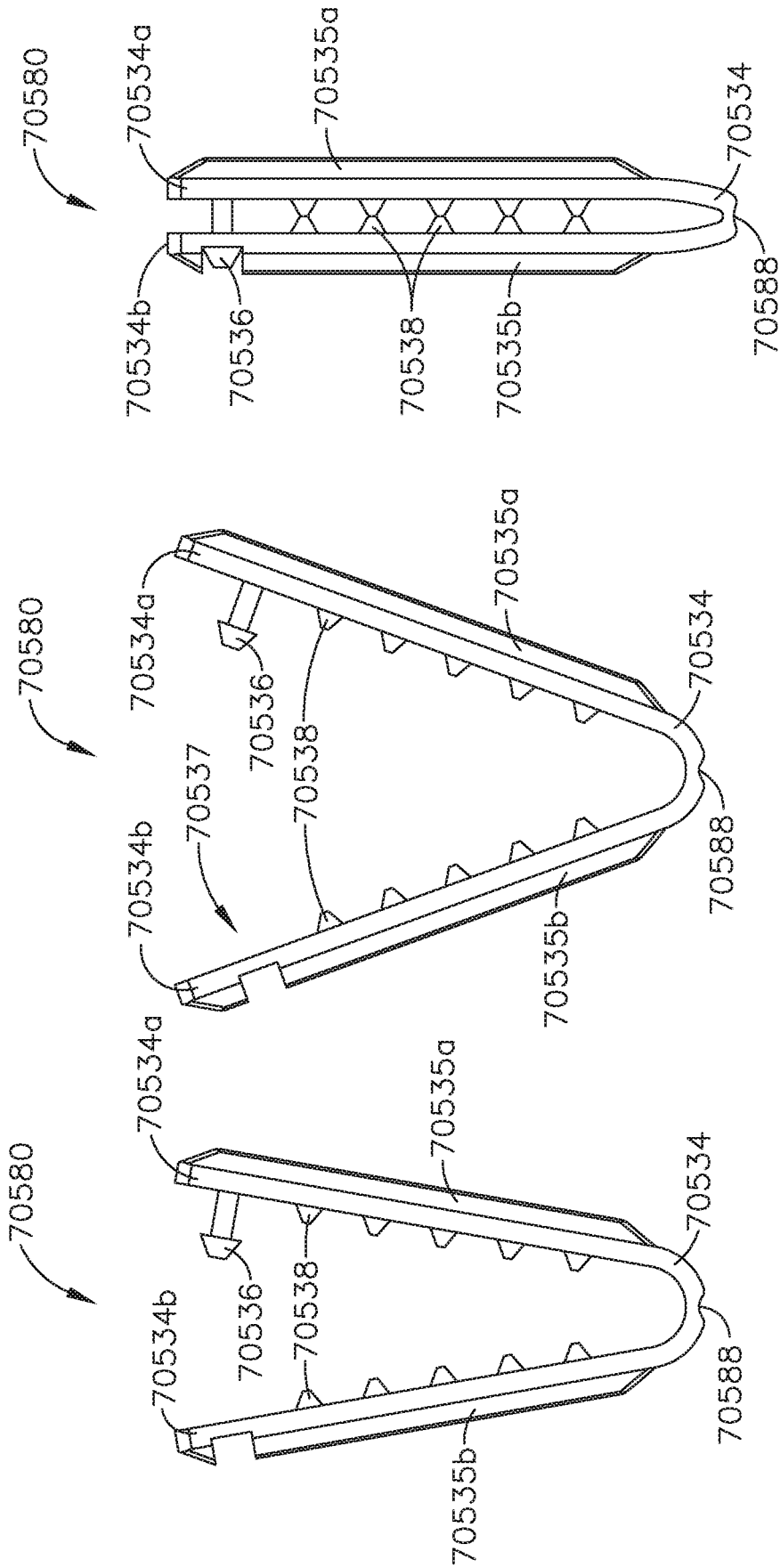

FIG. 51D

FIG. 51E

FIG. 51F

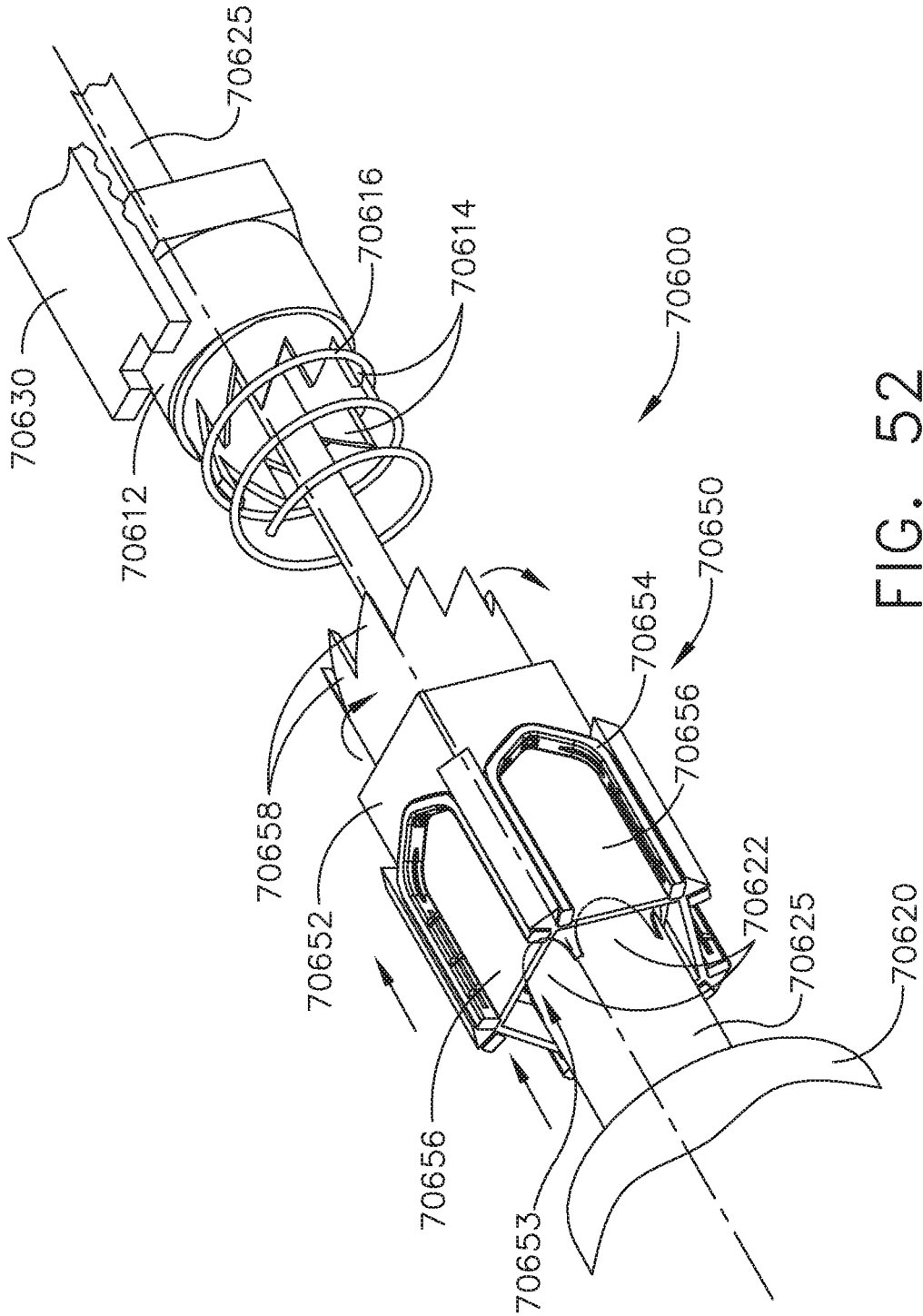

FIG. 52

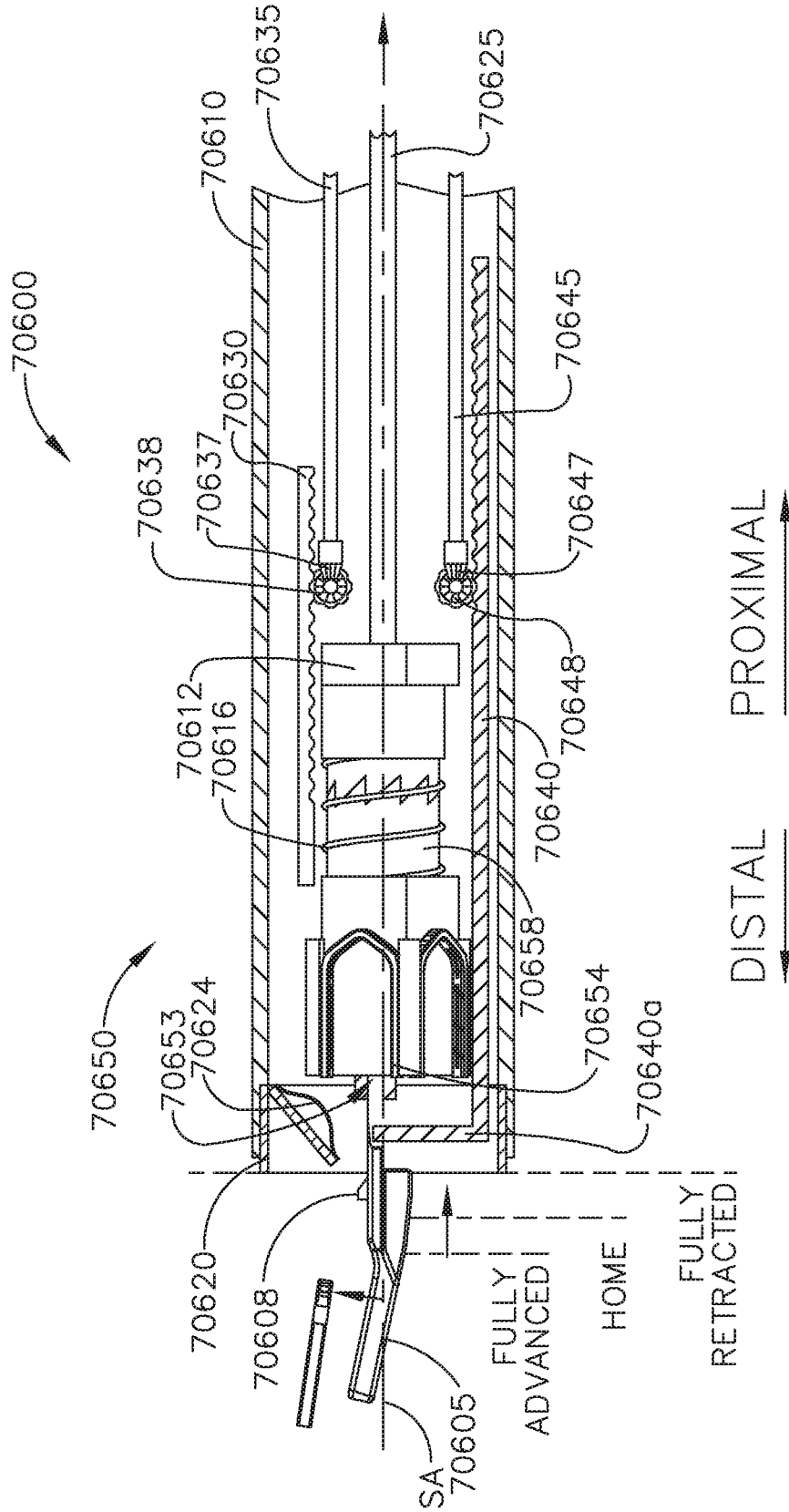

FIG. 53

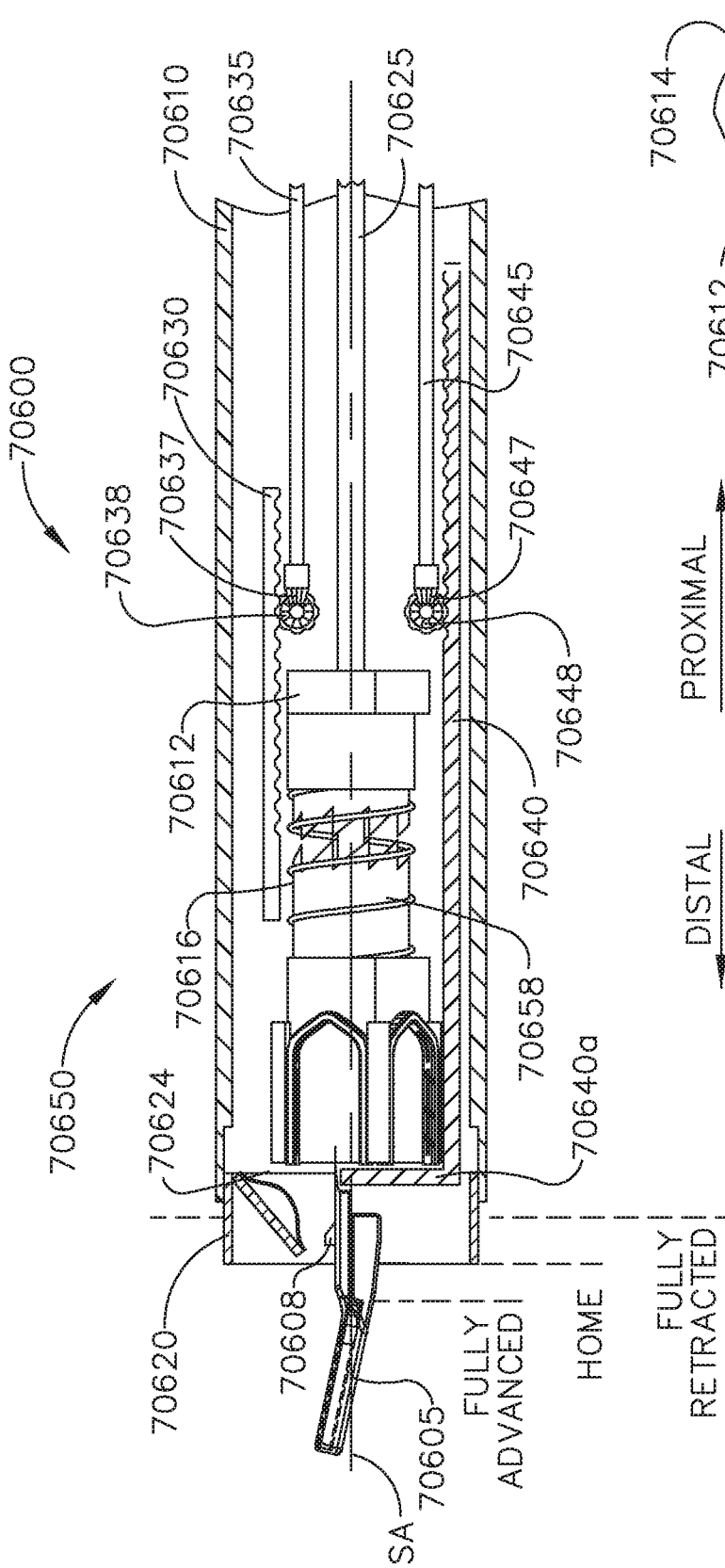

FIG. 54A

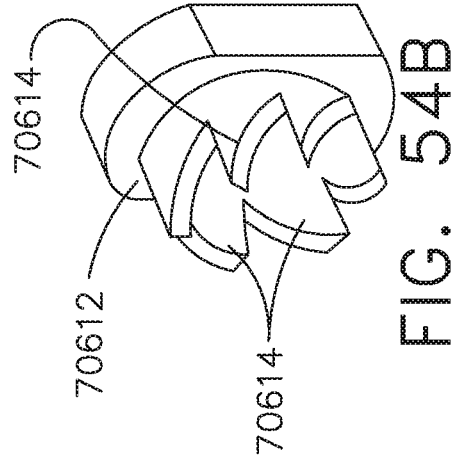

FIG. 54B

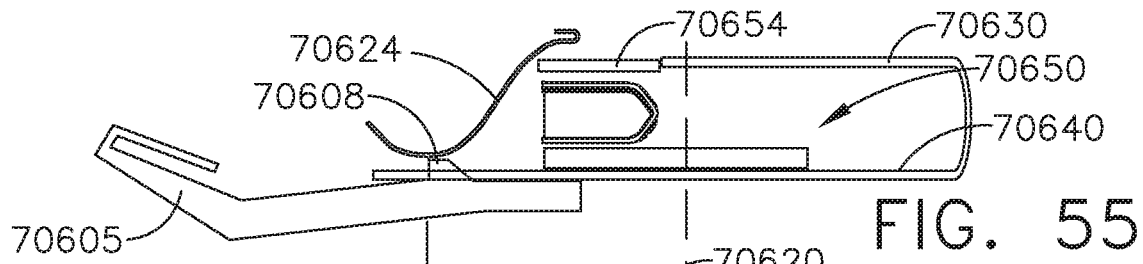

FIG. 55

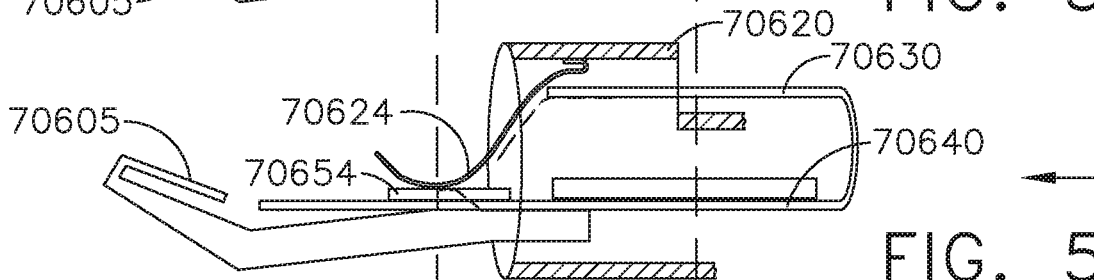

FIG. 56

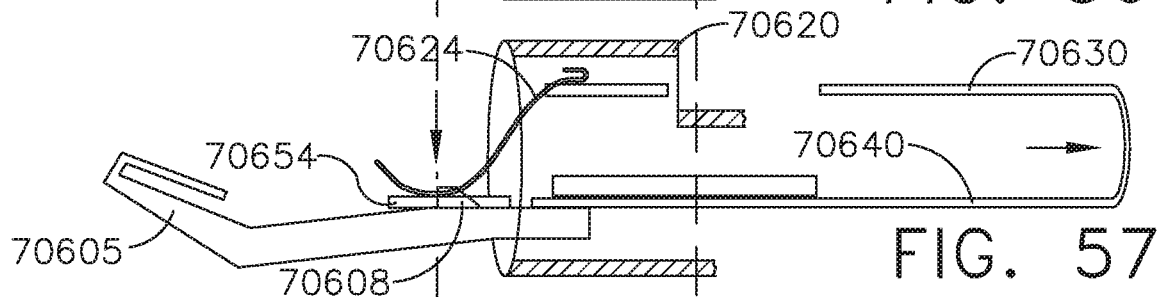

FIG. 57

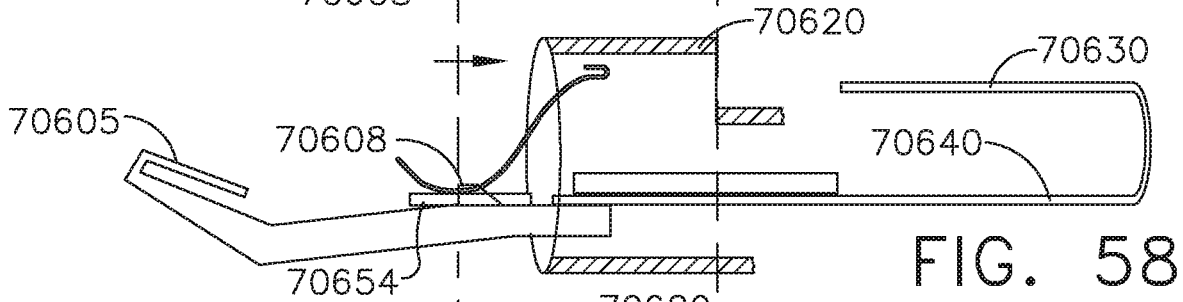

FIG. 58

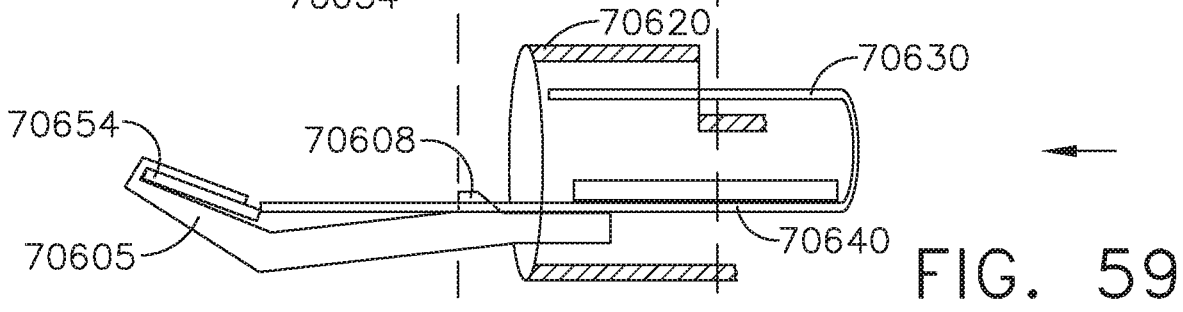

FIG. 59

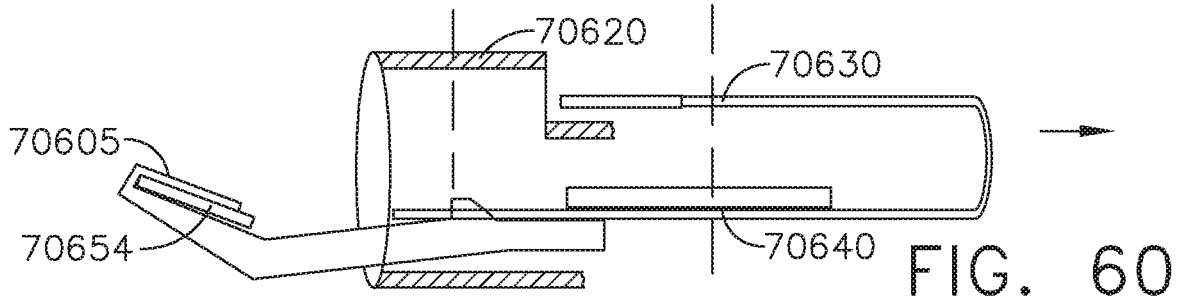

FIG. 60

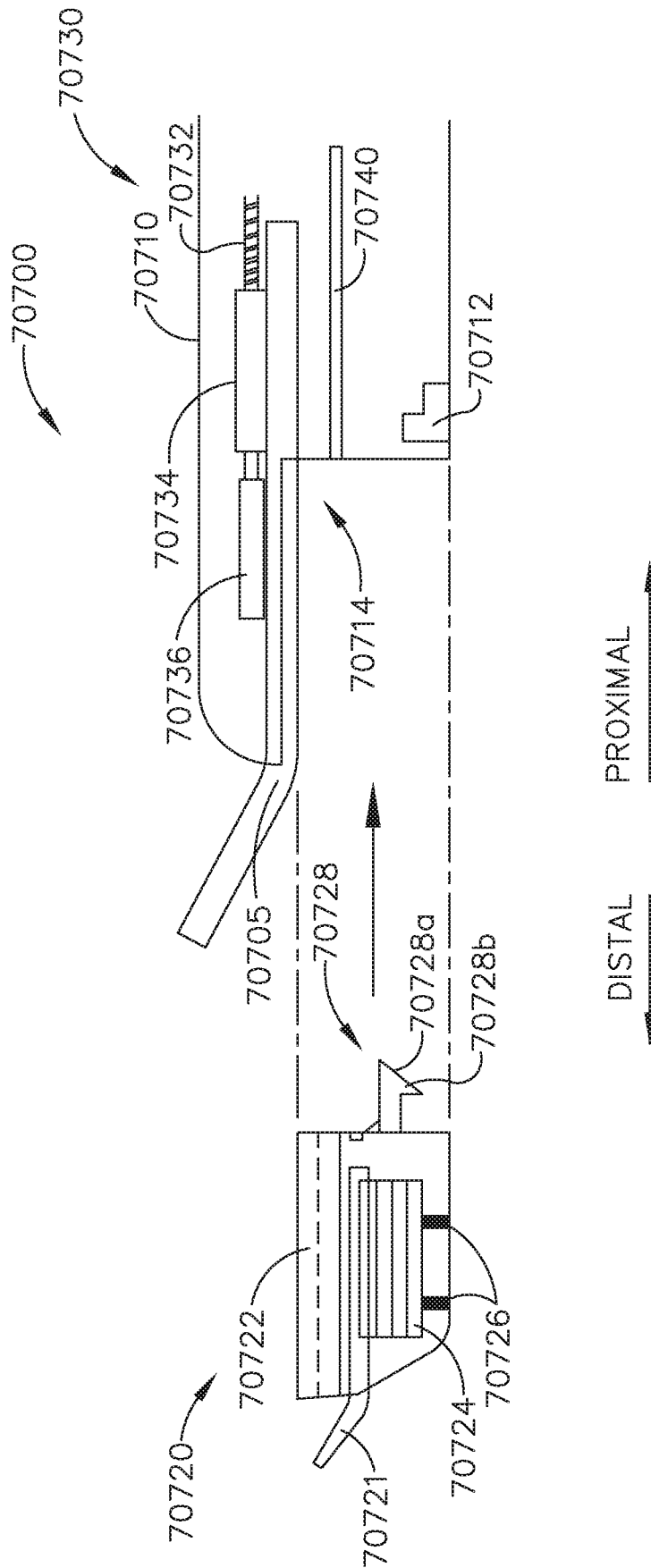

FIG. 61

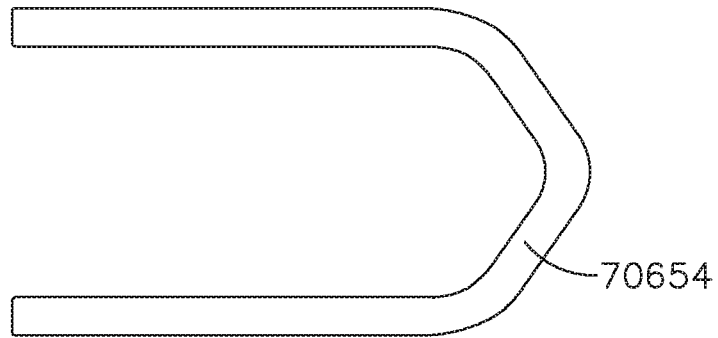

FIG. 62B

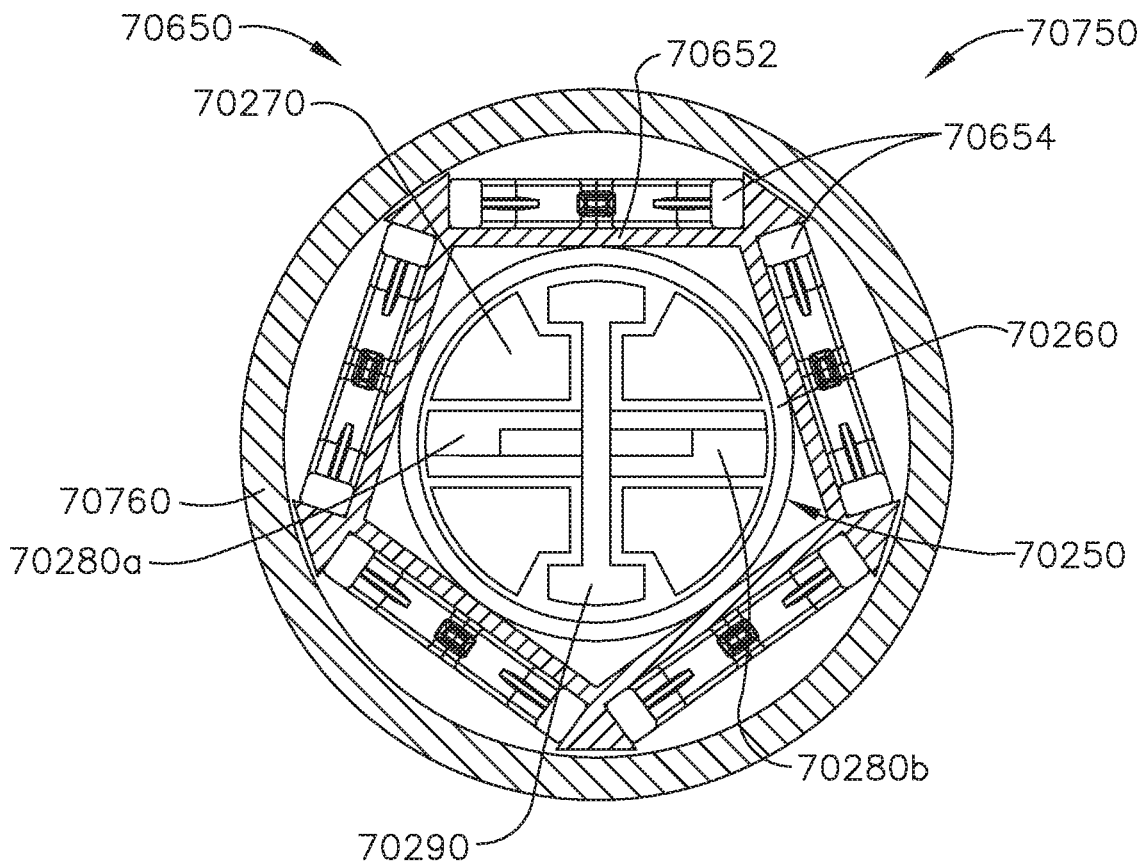

FIG. 62A

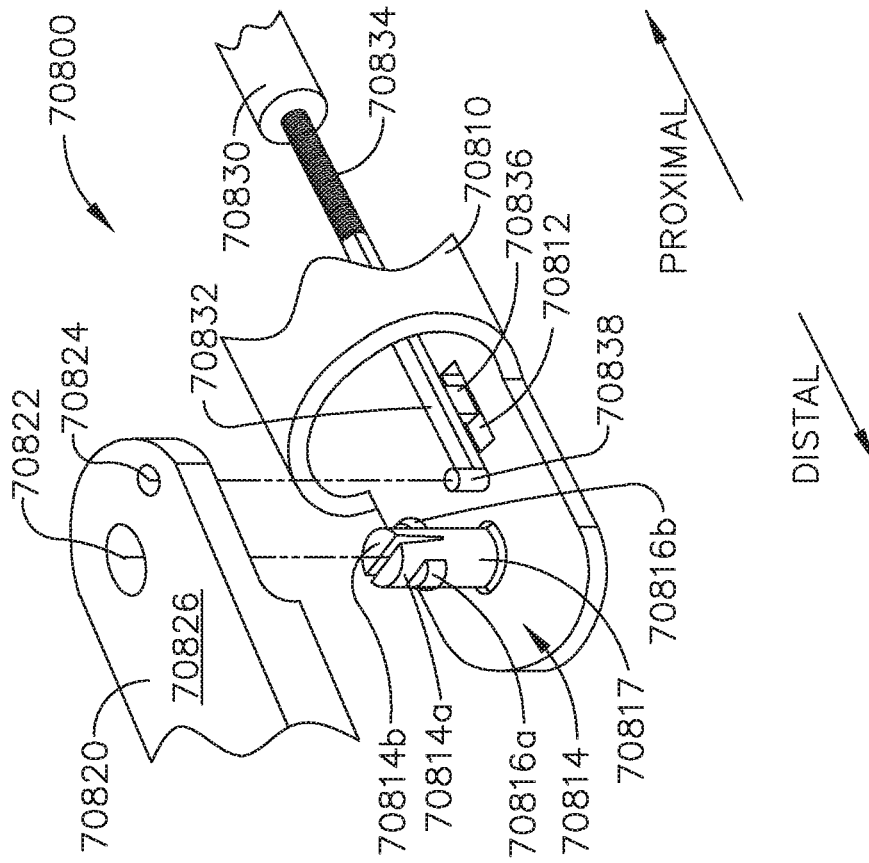

FIG. 63A

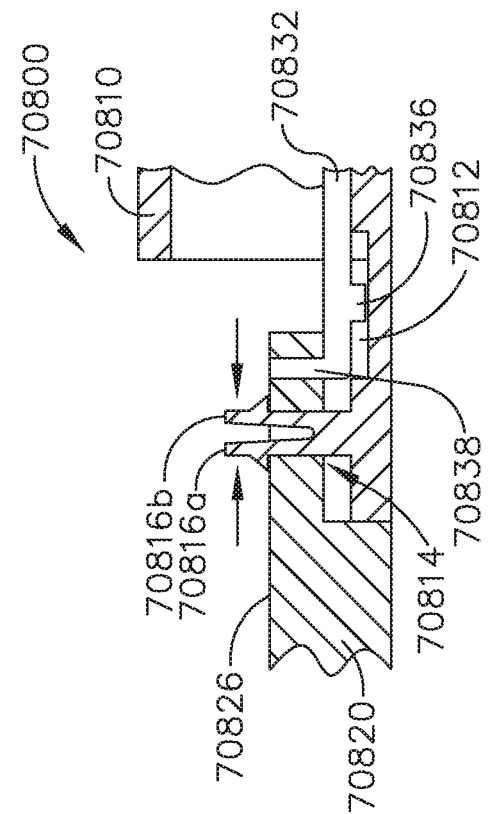

FIG. 63B

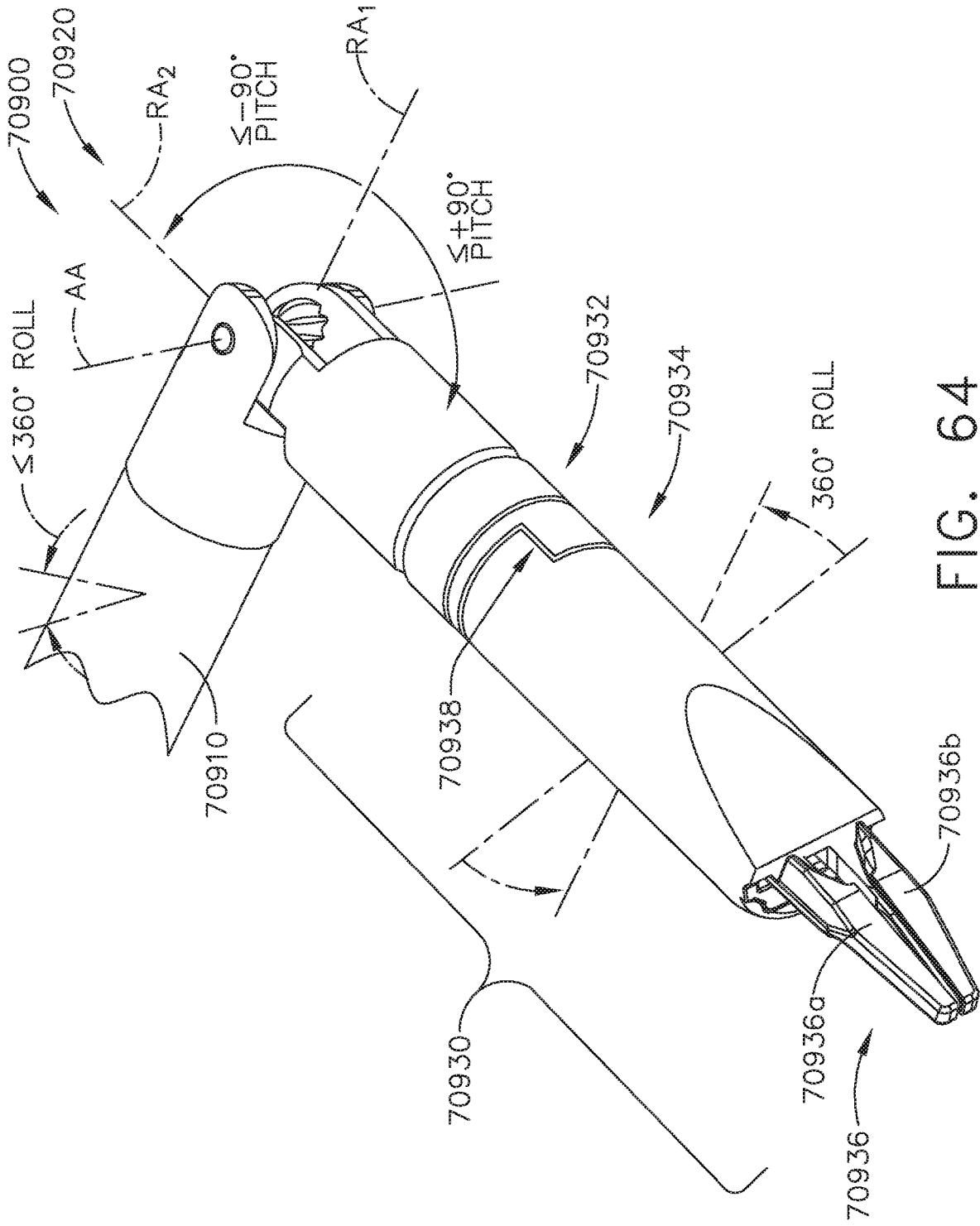

FIG. 64

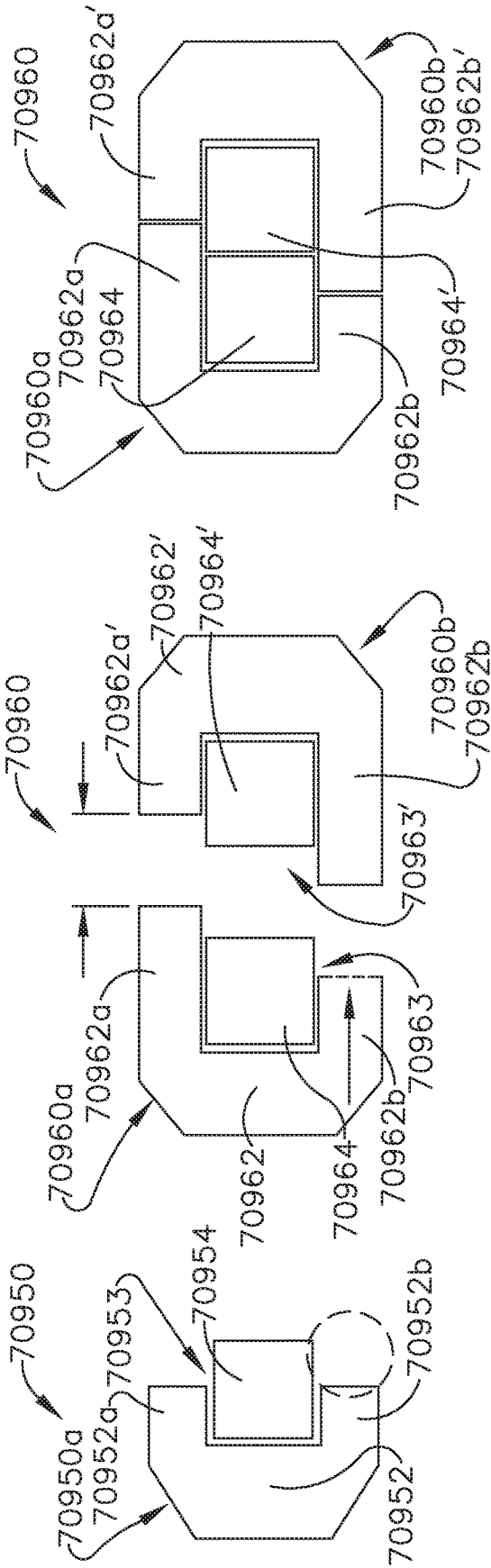

FIG. 65

FIG. 66A

FIG. 66B

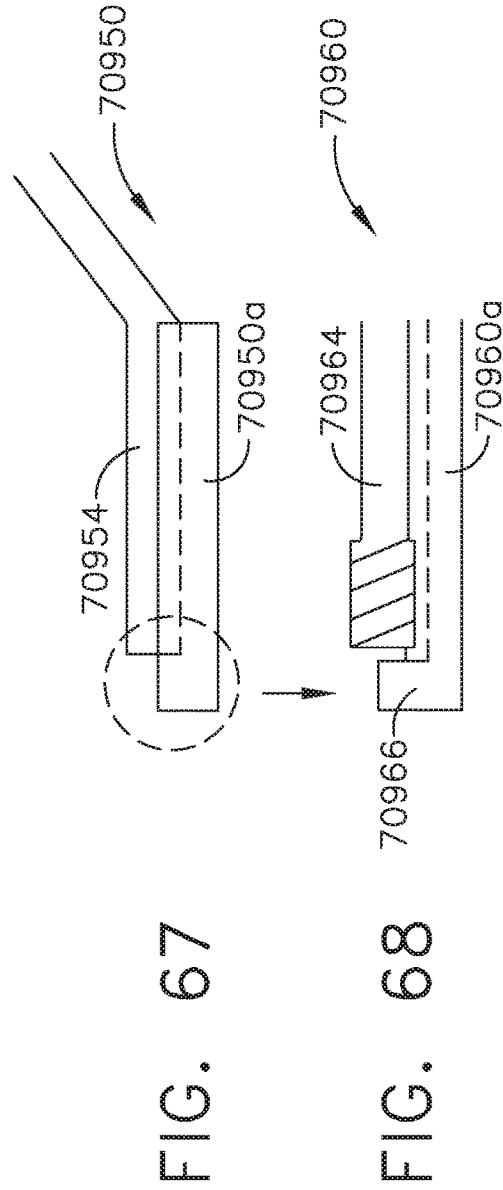

FIG. 67

FIG. 68

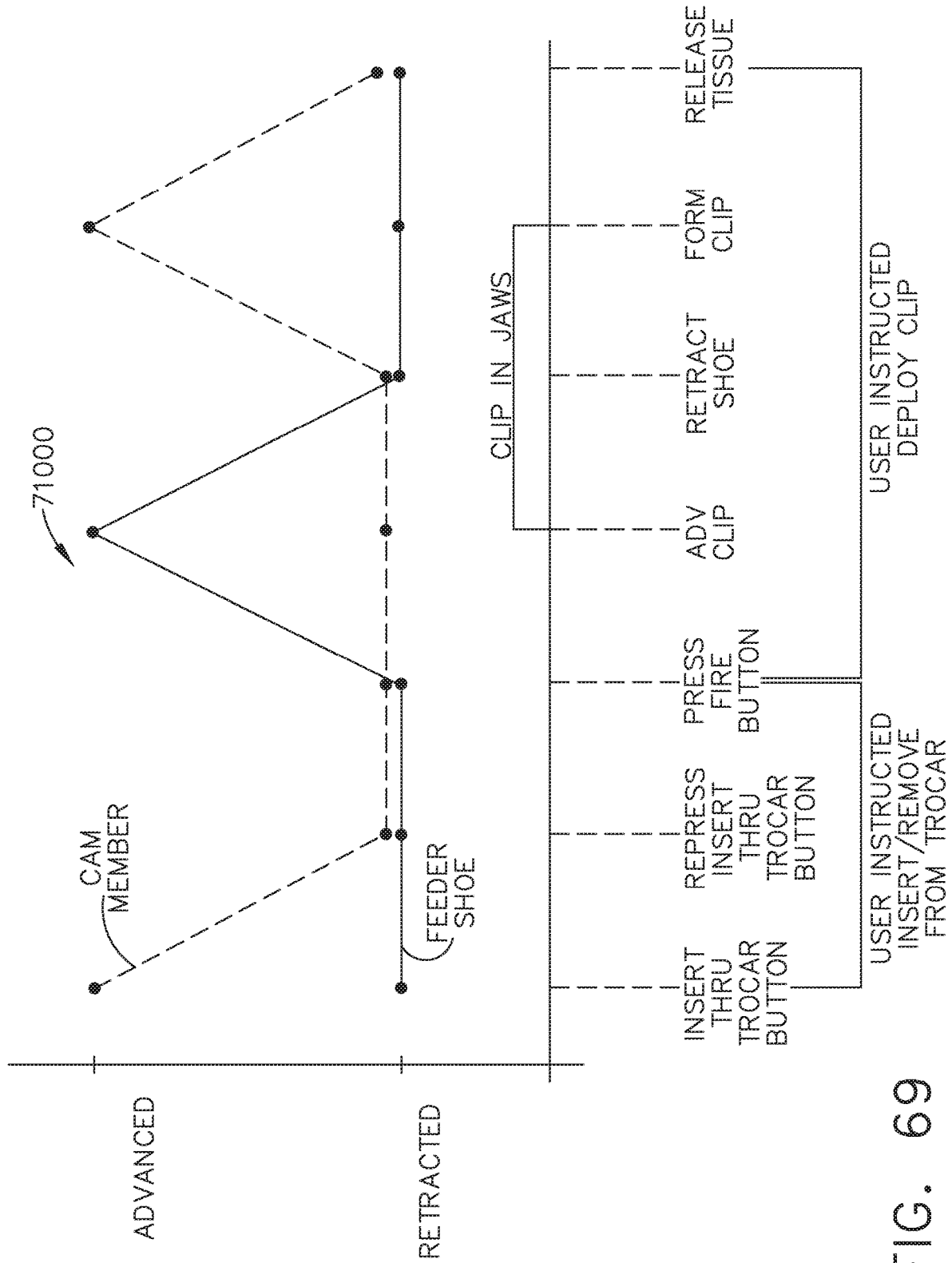

FIG. 69

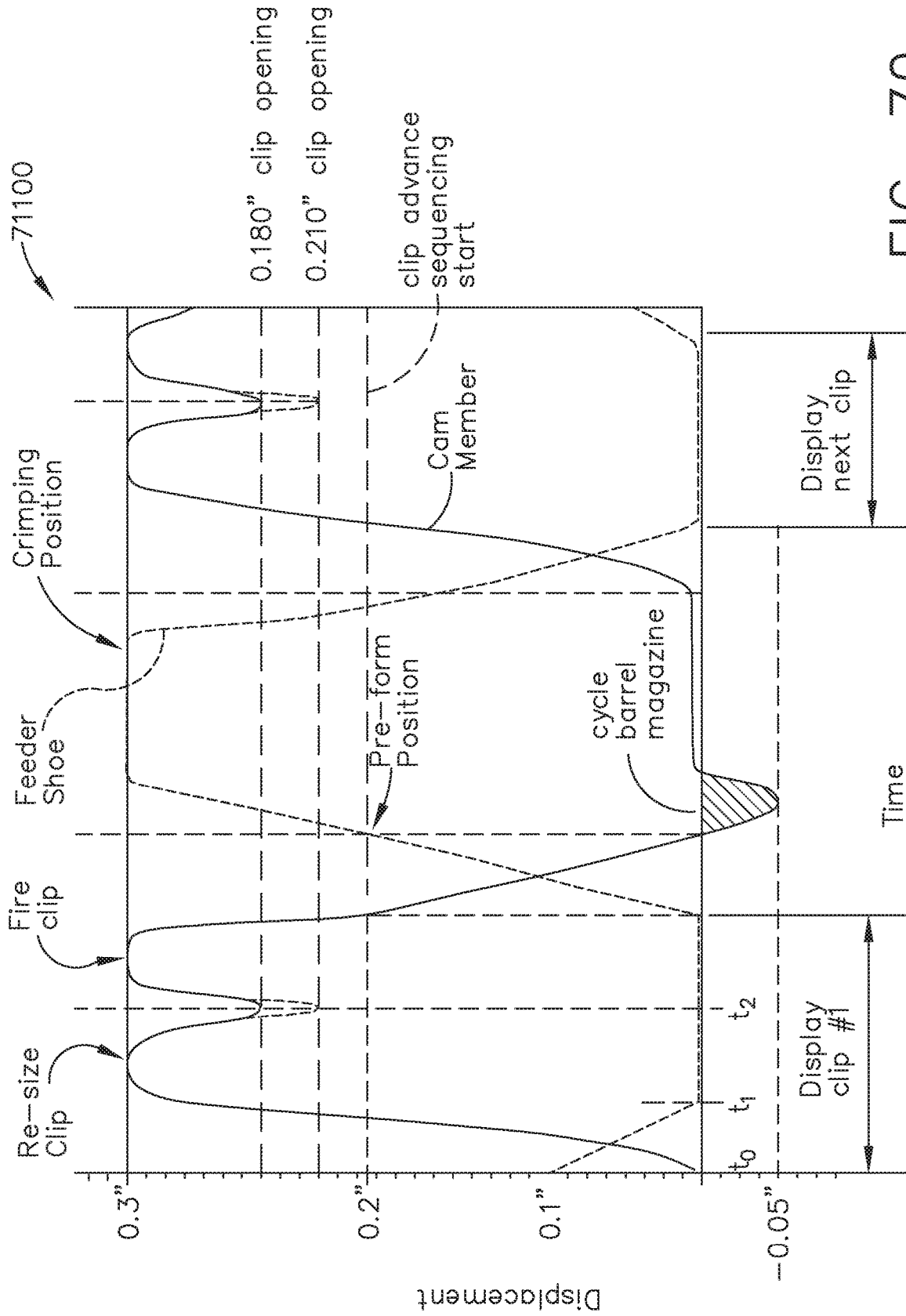

FIG. 70

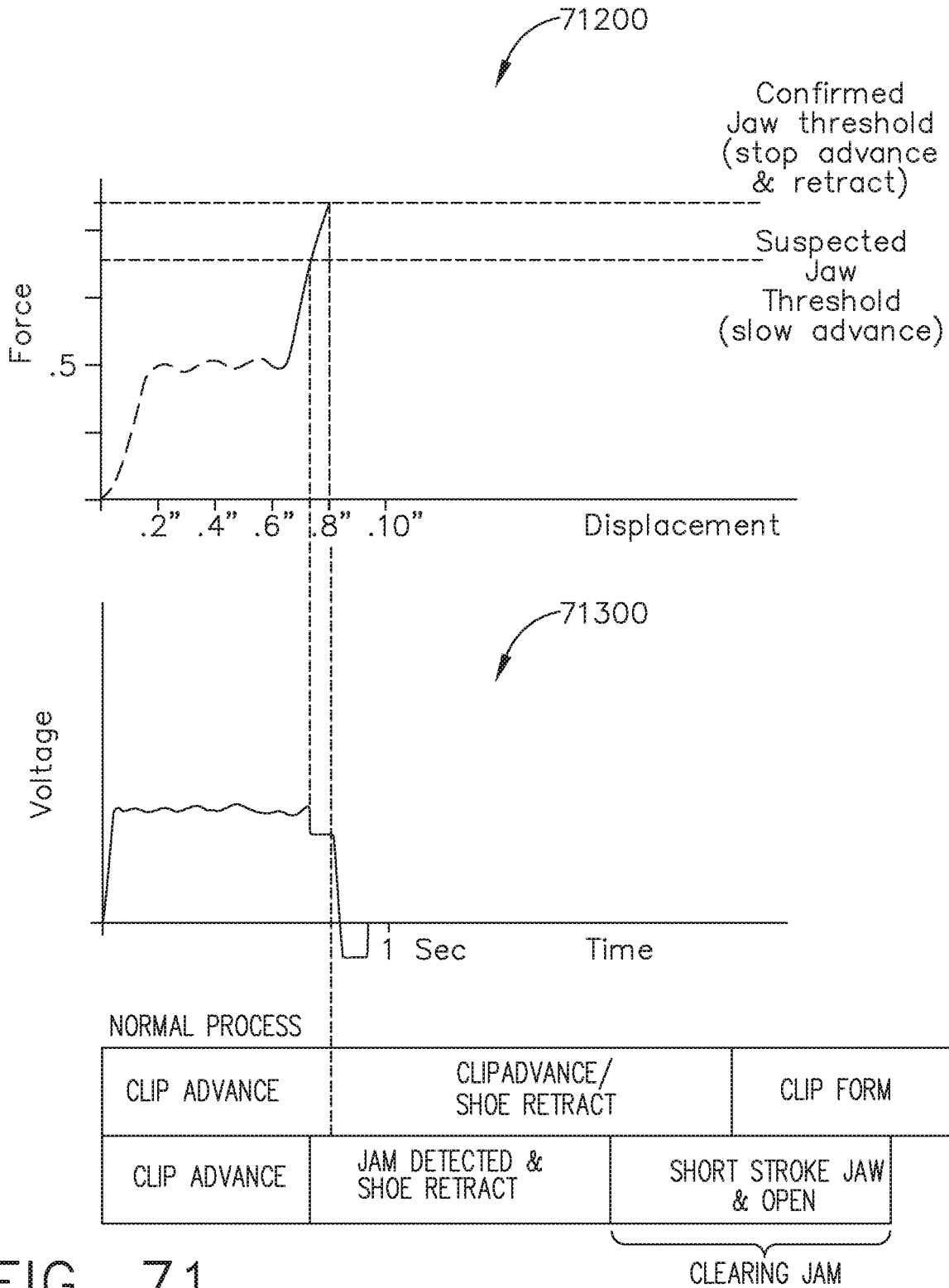

FIG. 71

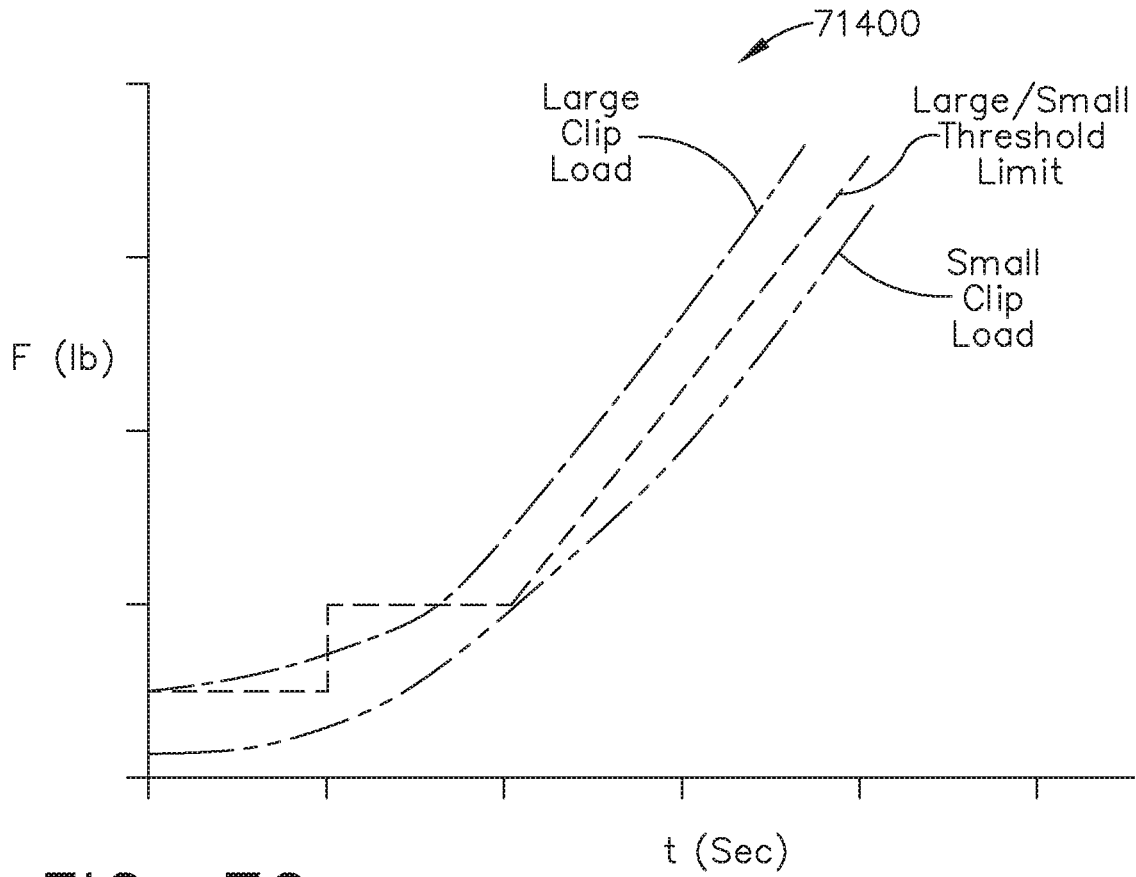

FIG. 72

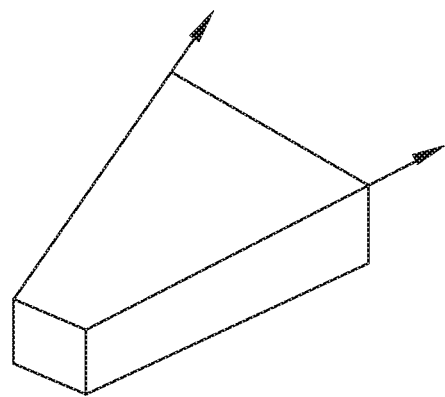

FIG. 73

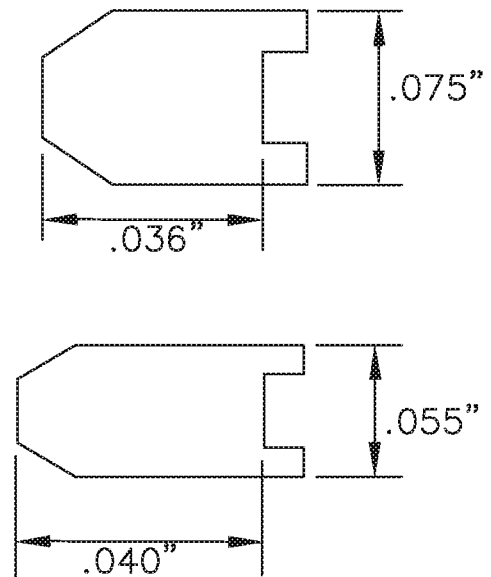

FIG. 74

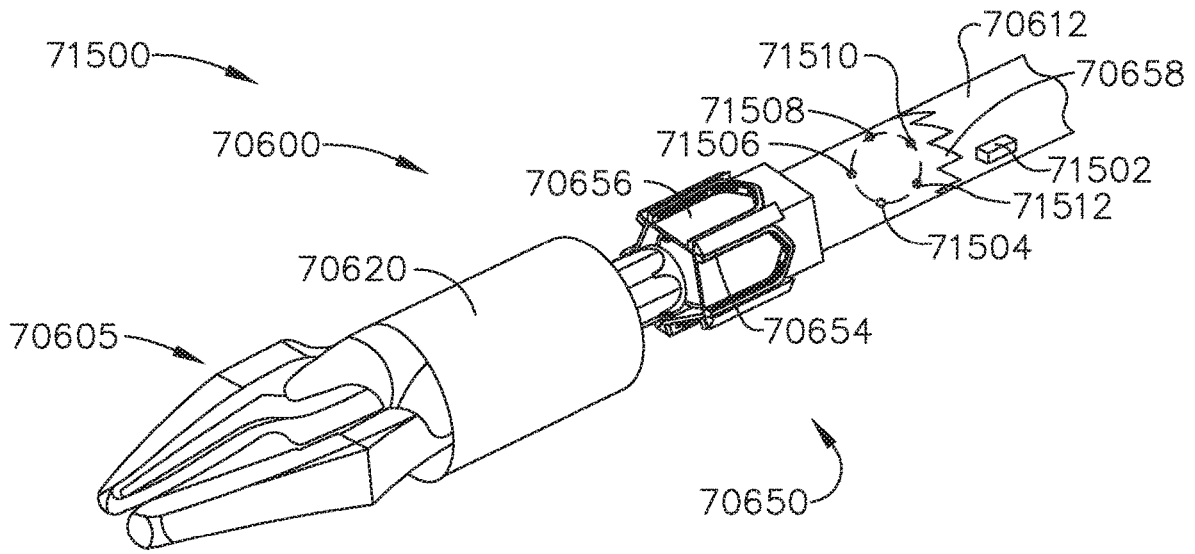

FIG. 75

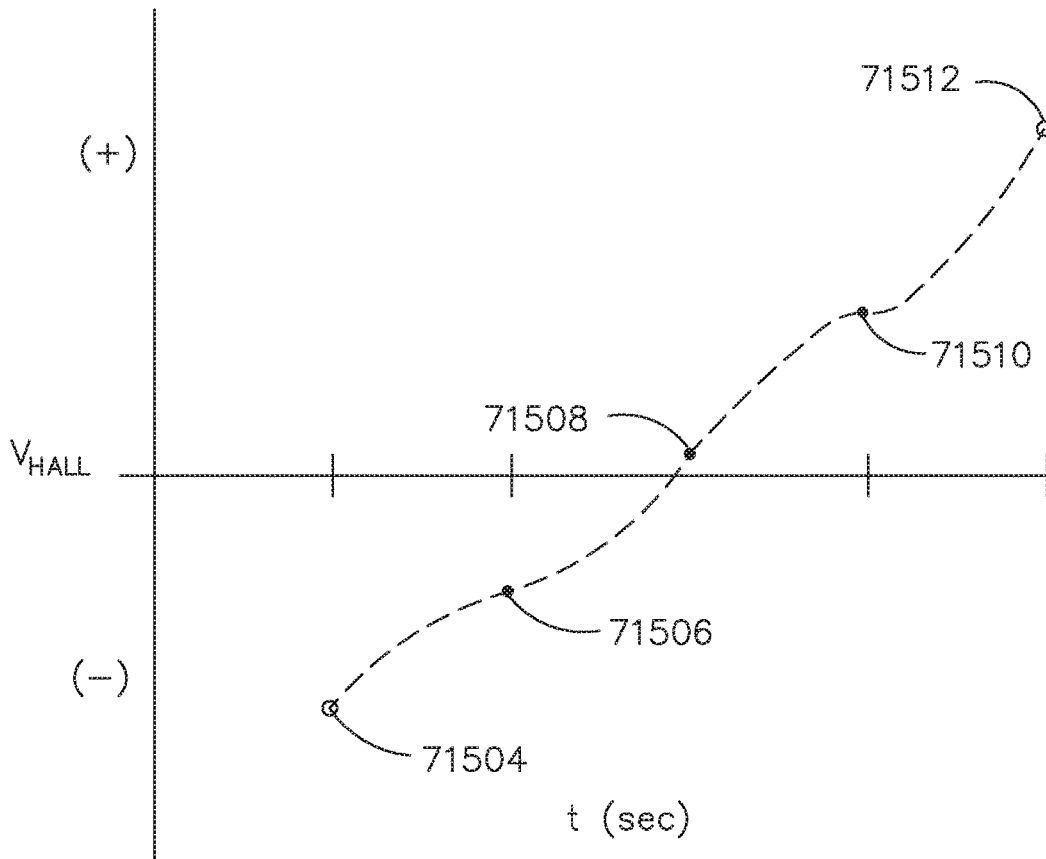

FIG. 76

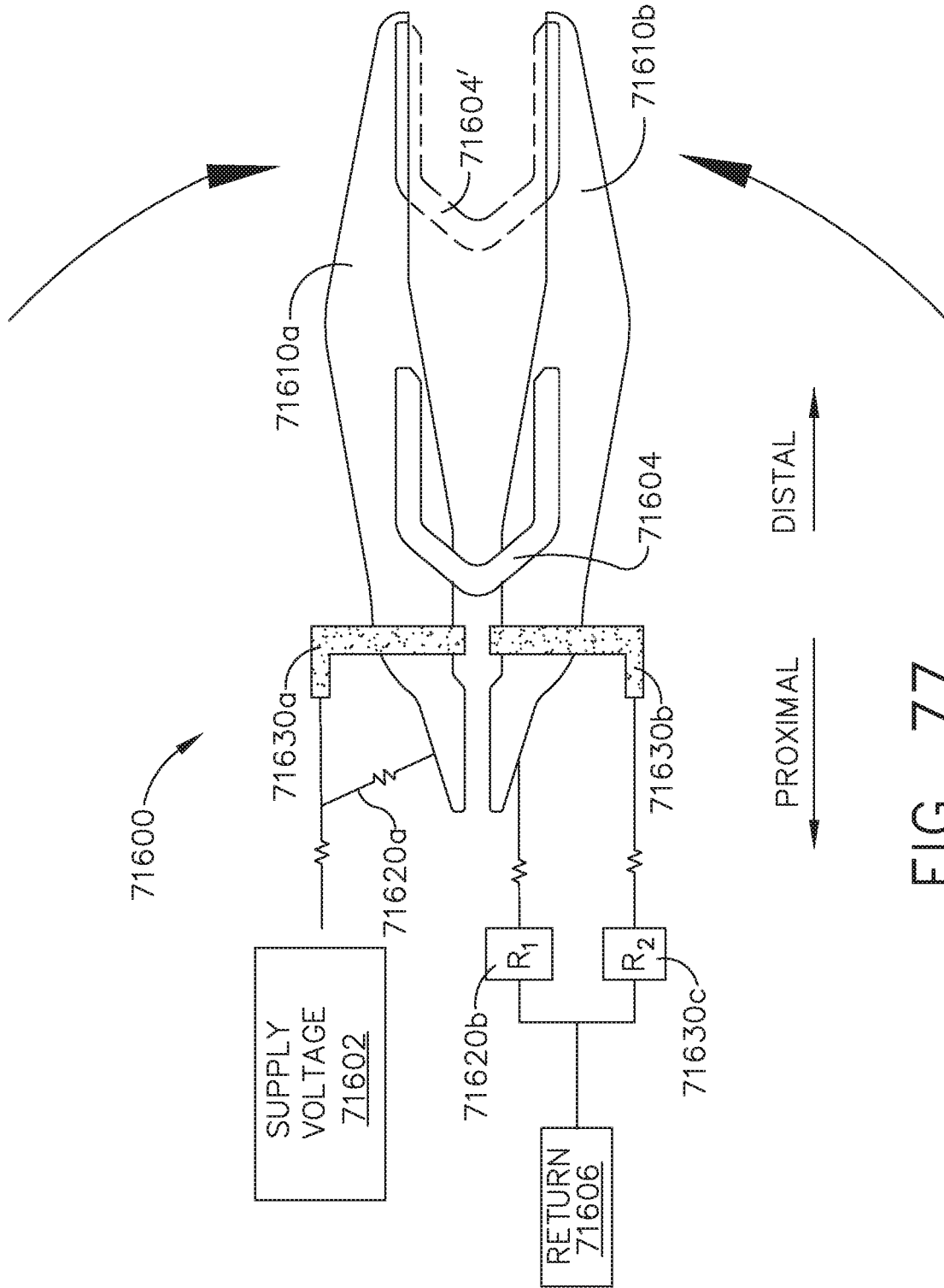

FIG. 77

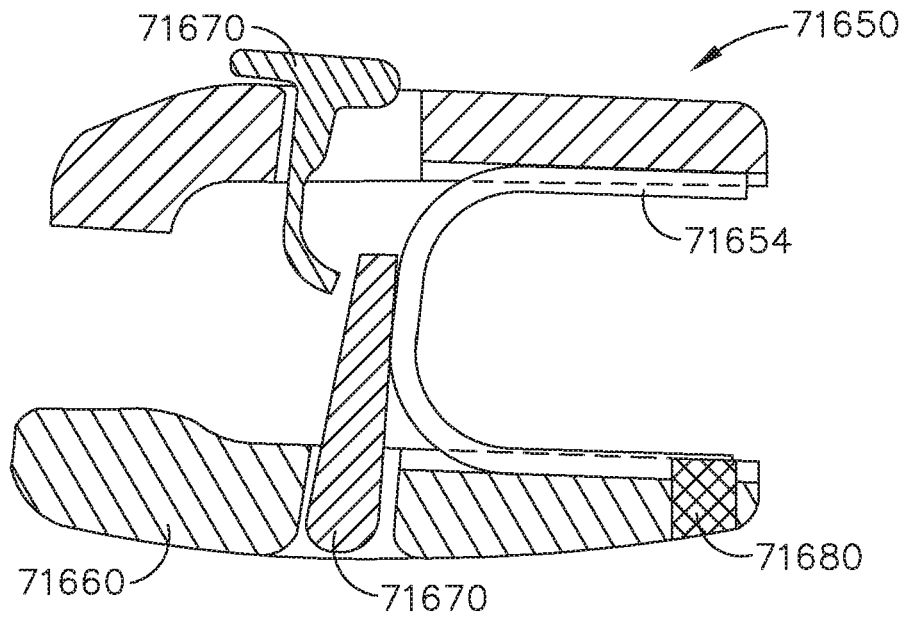

FIG. 78A

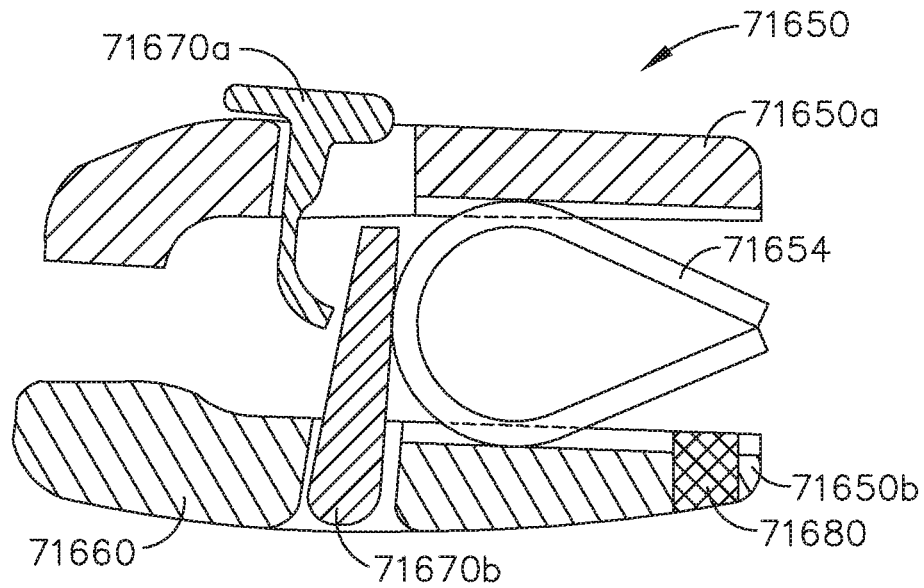

FIG. 78B

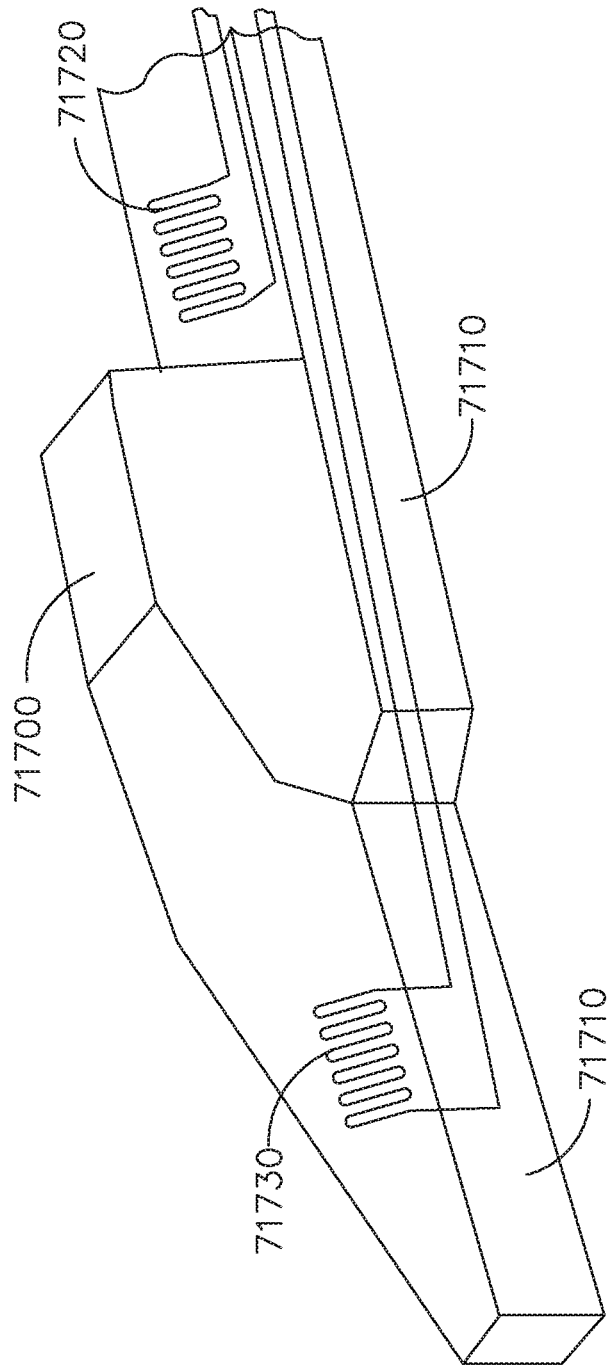

FIG. 79

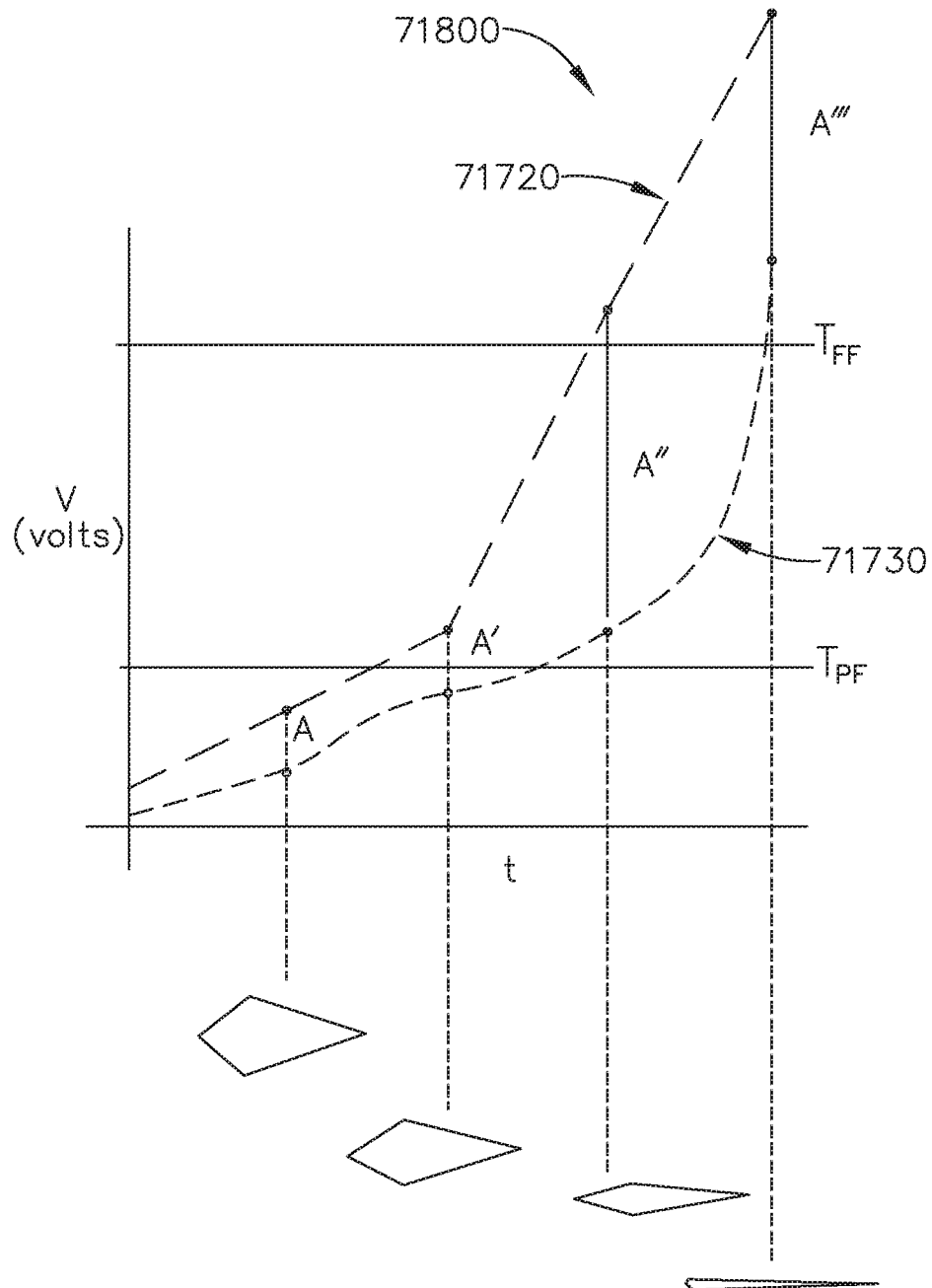

FIG. 80

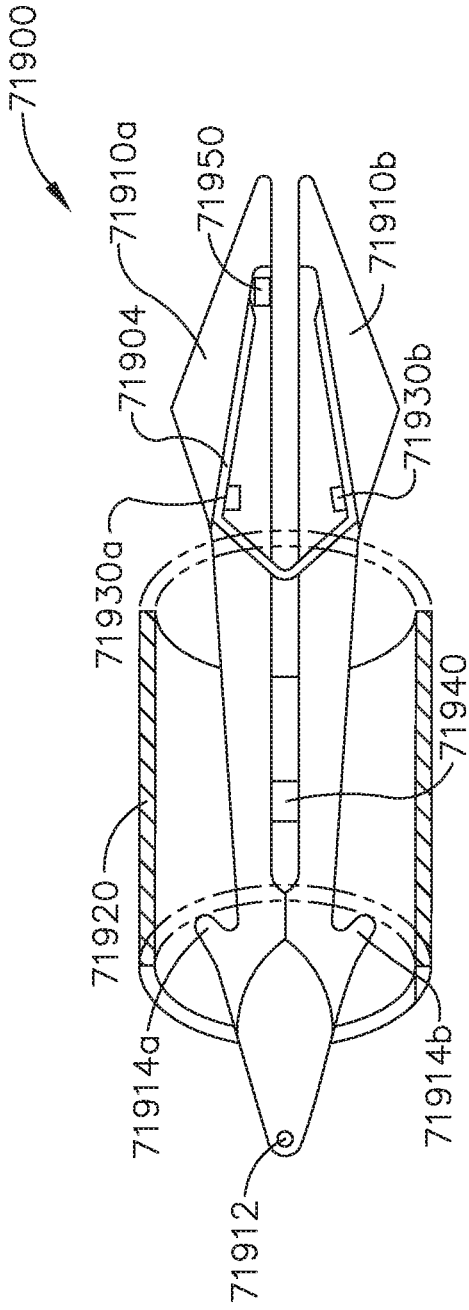

FIG. 81A

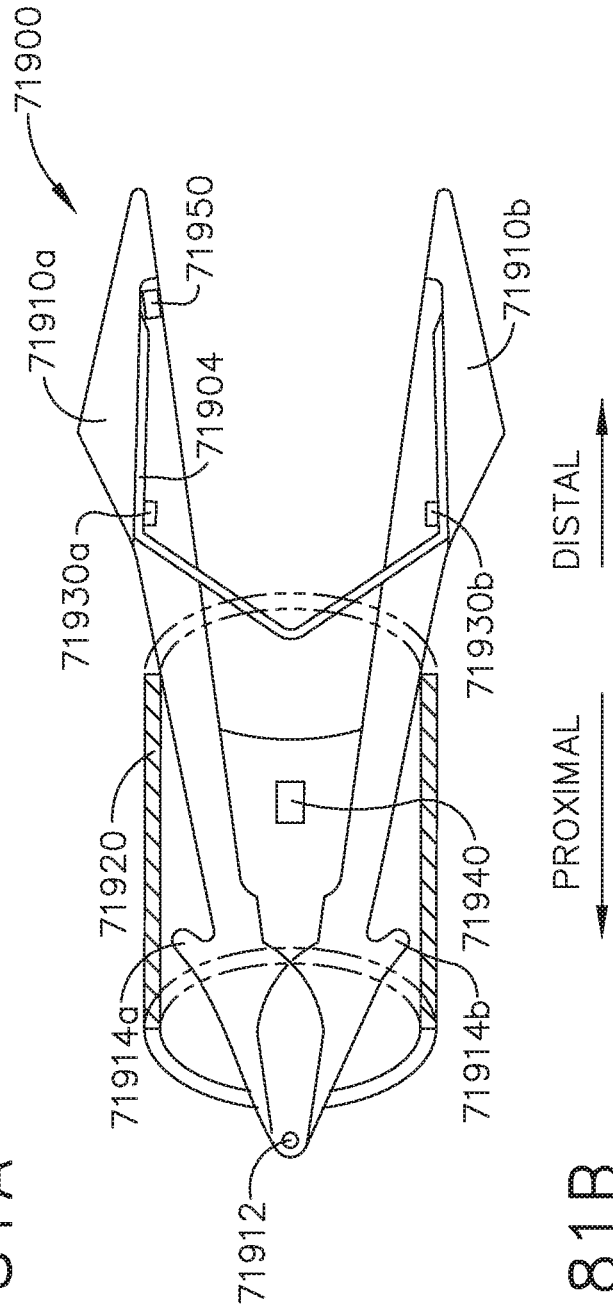

FIG. 81B

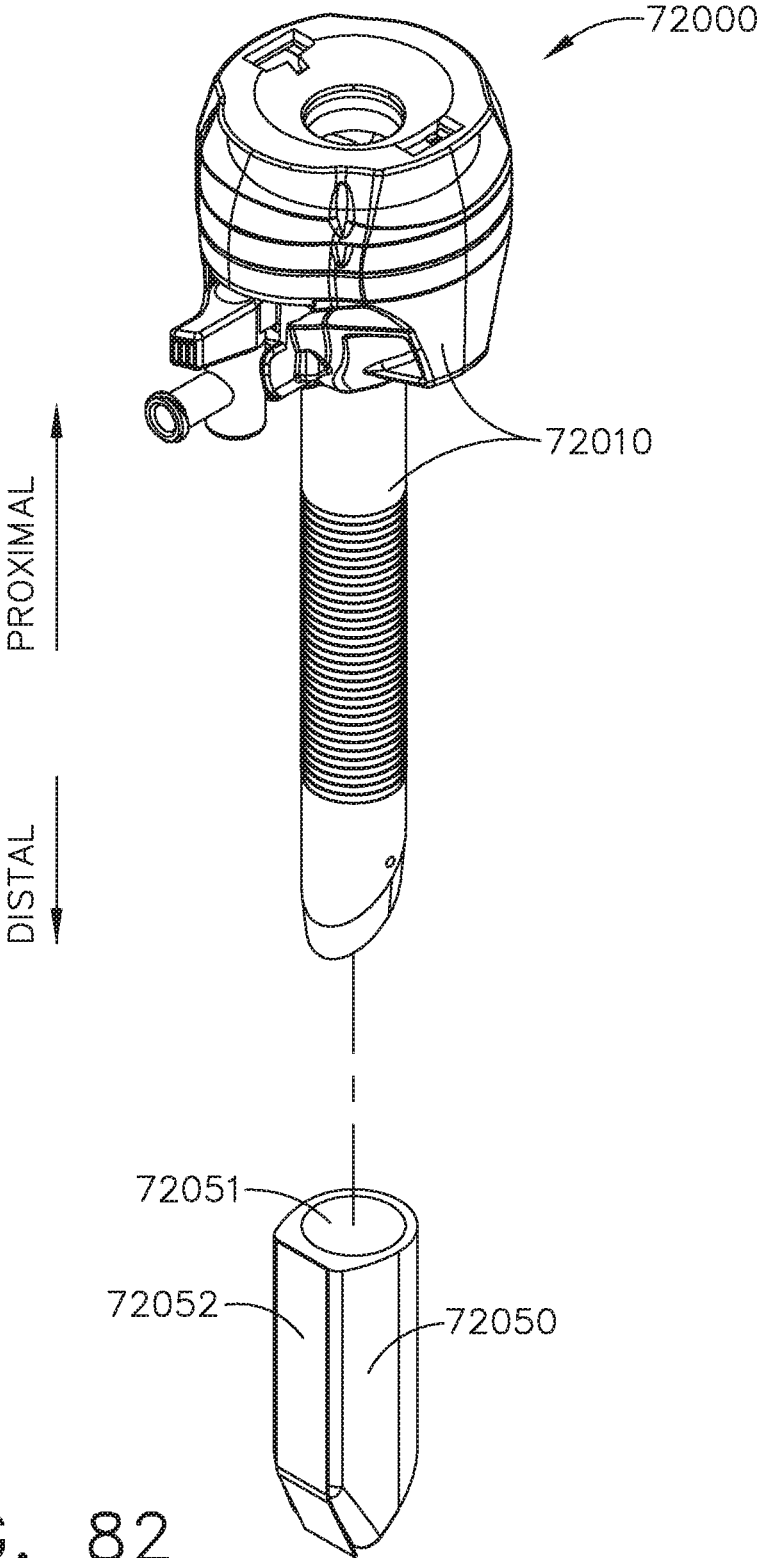

FIG. 82

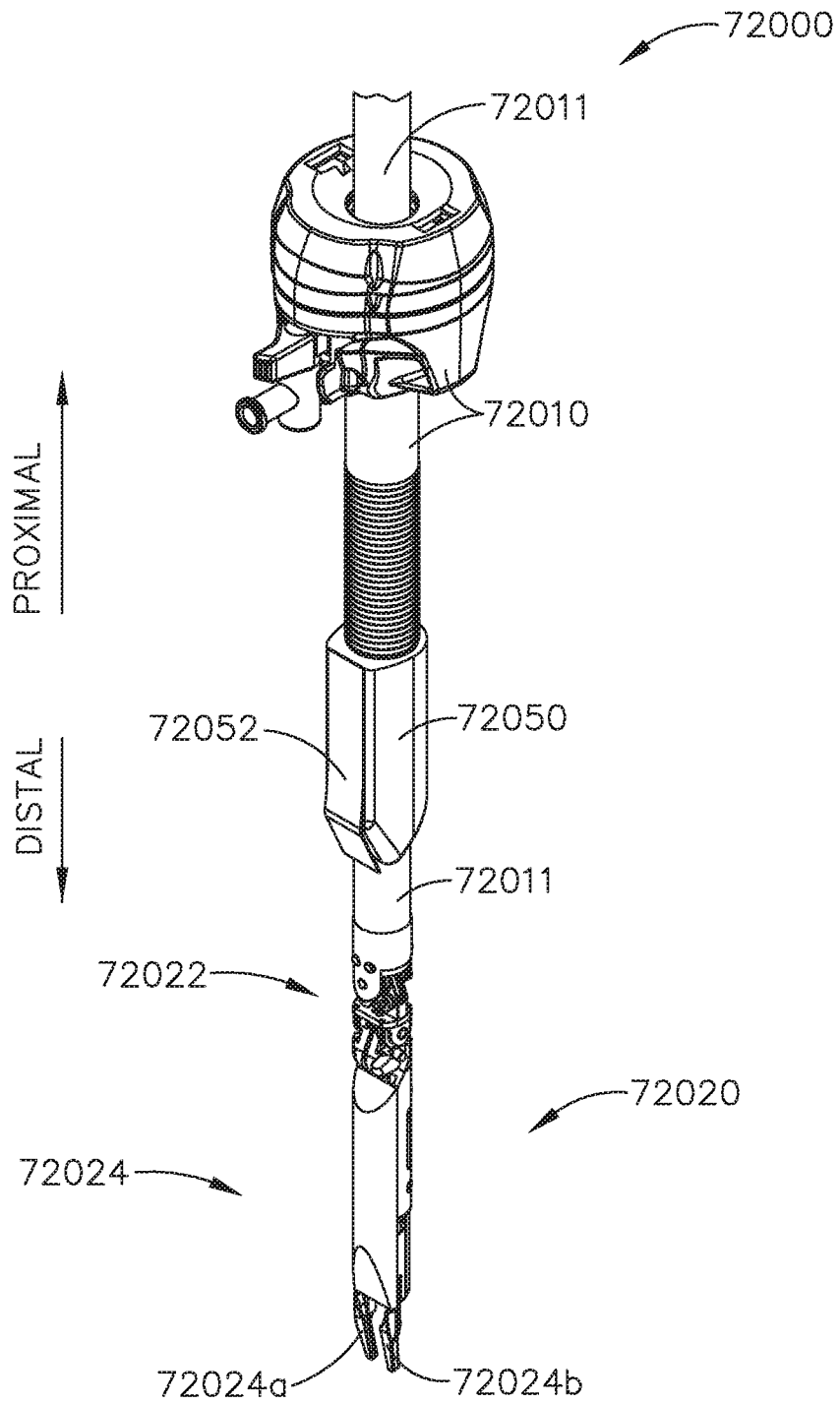

FIG. 83

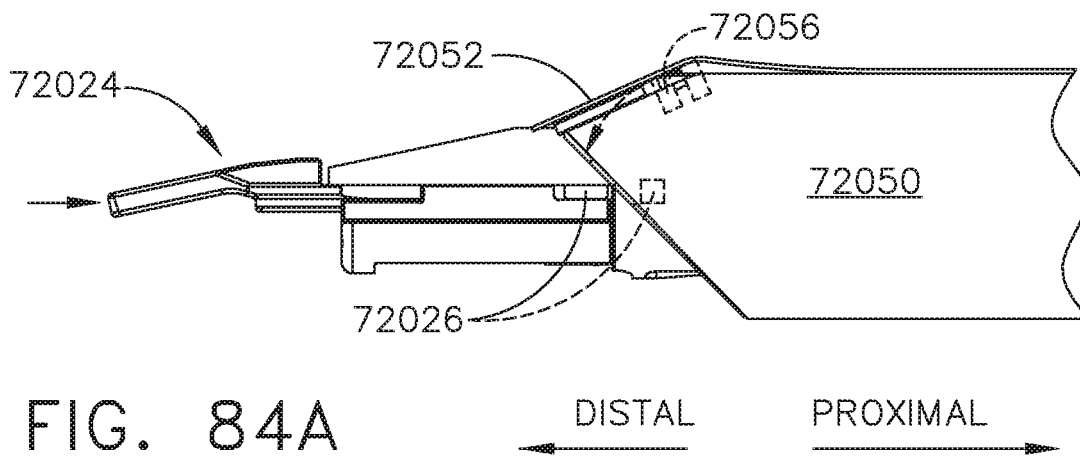

FIG. 84A

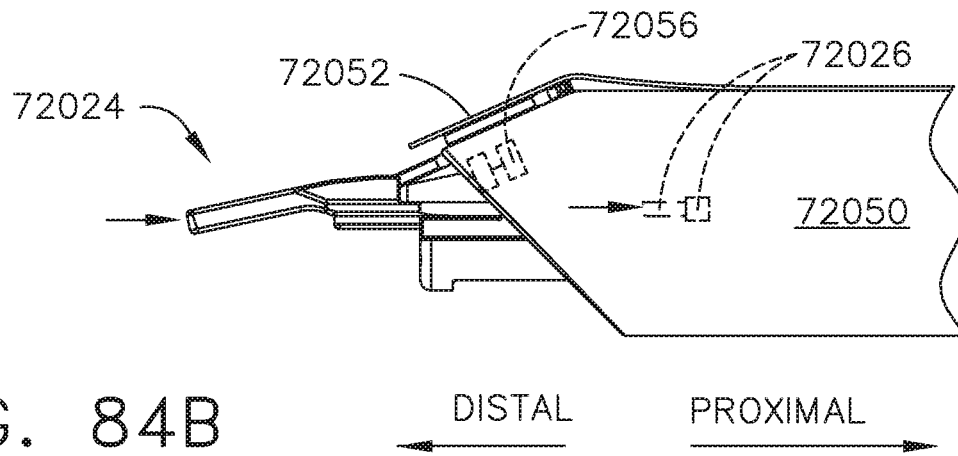

FIG. 84B

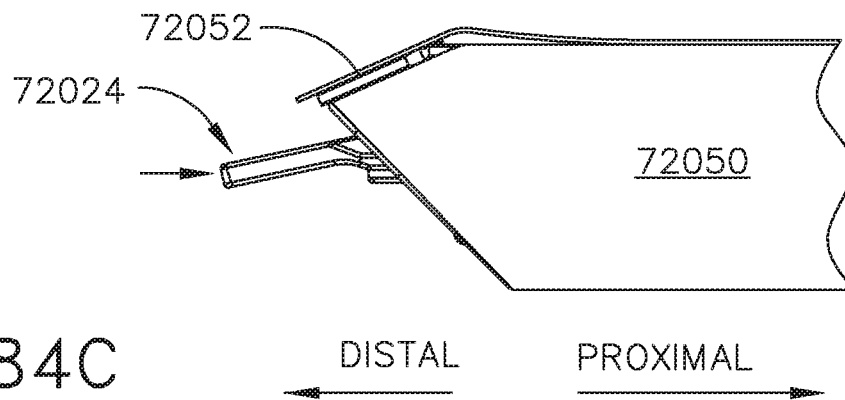

FIG. 84C

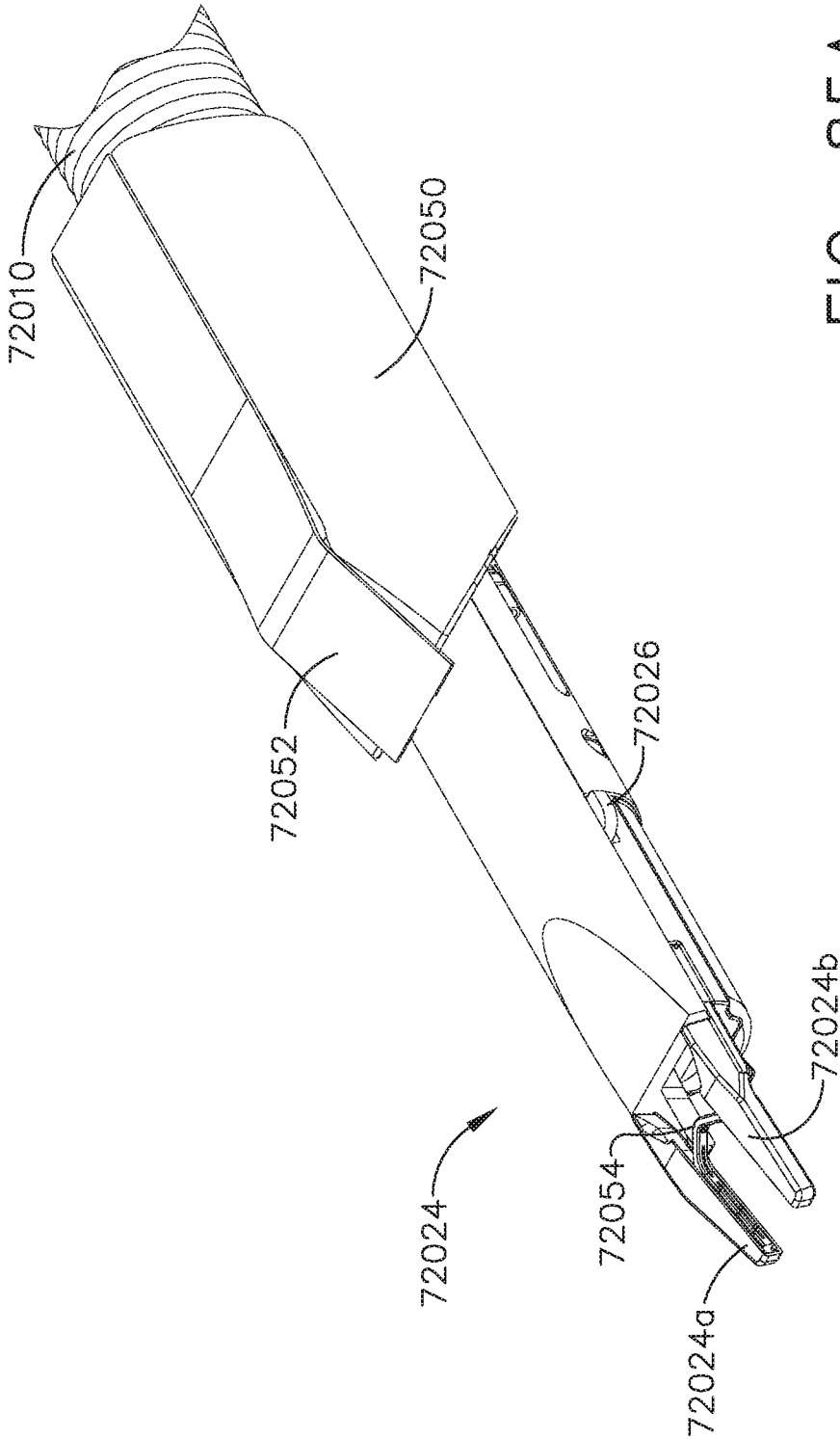

FIG. 85A

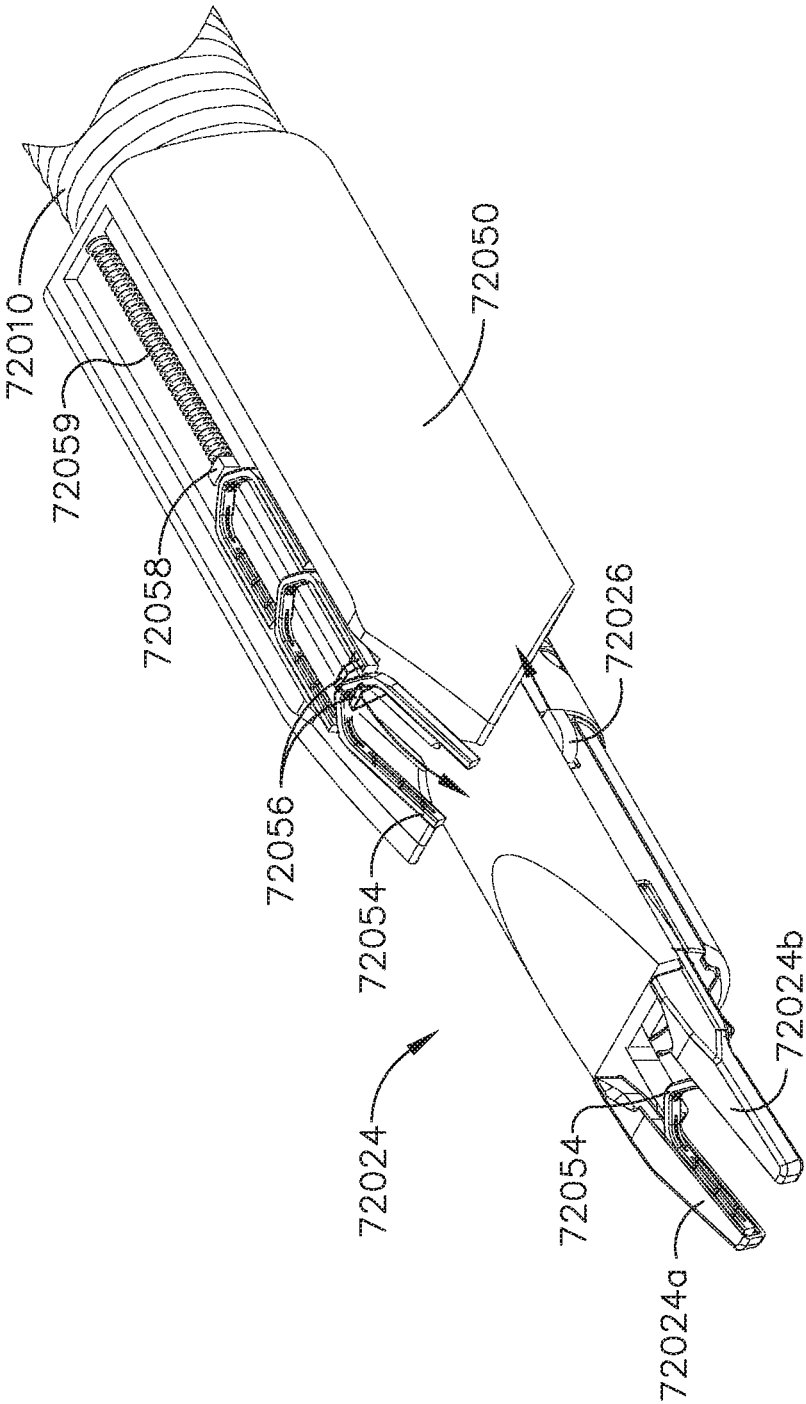

FIG. 85B

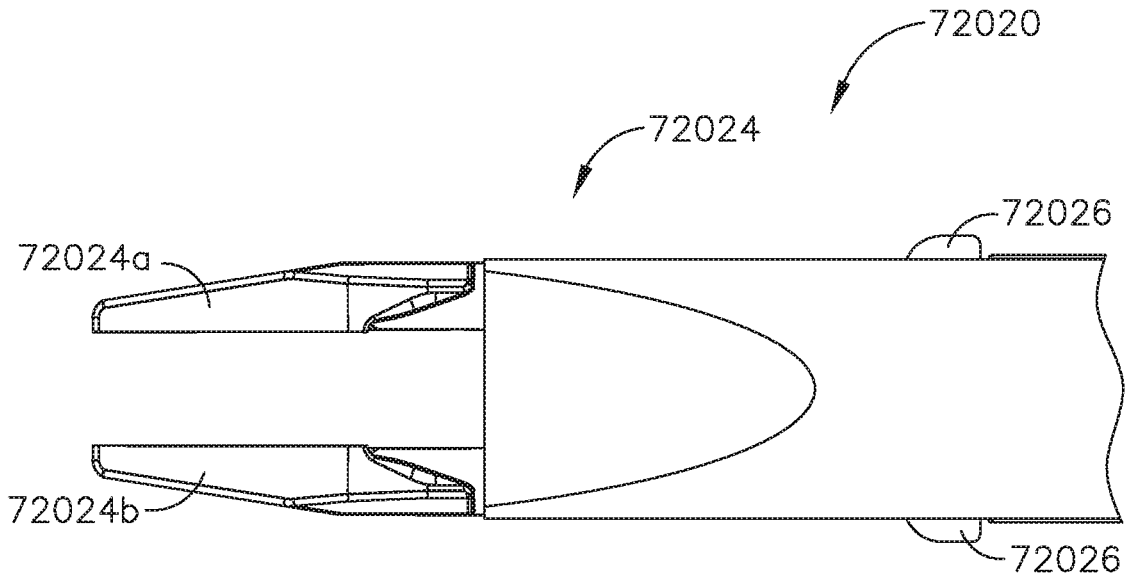

FIG. 86A

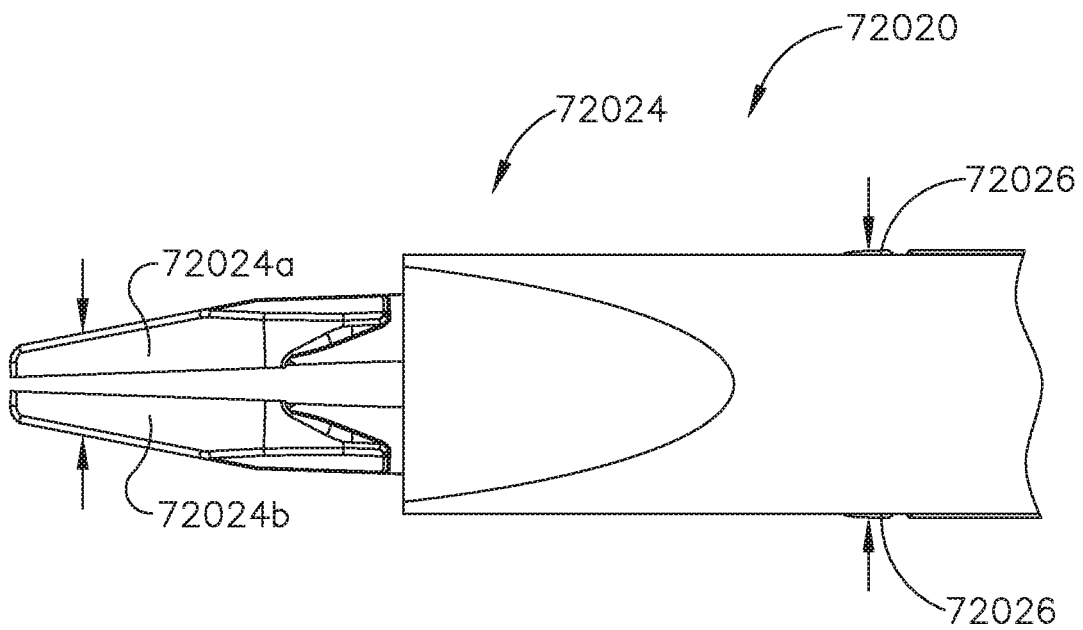

FIG. 86B

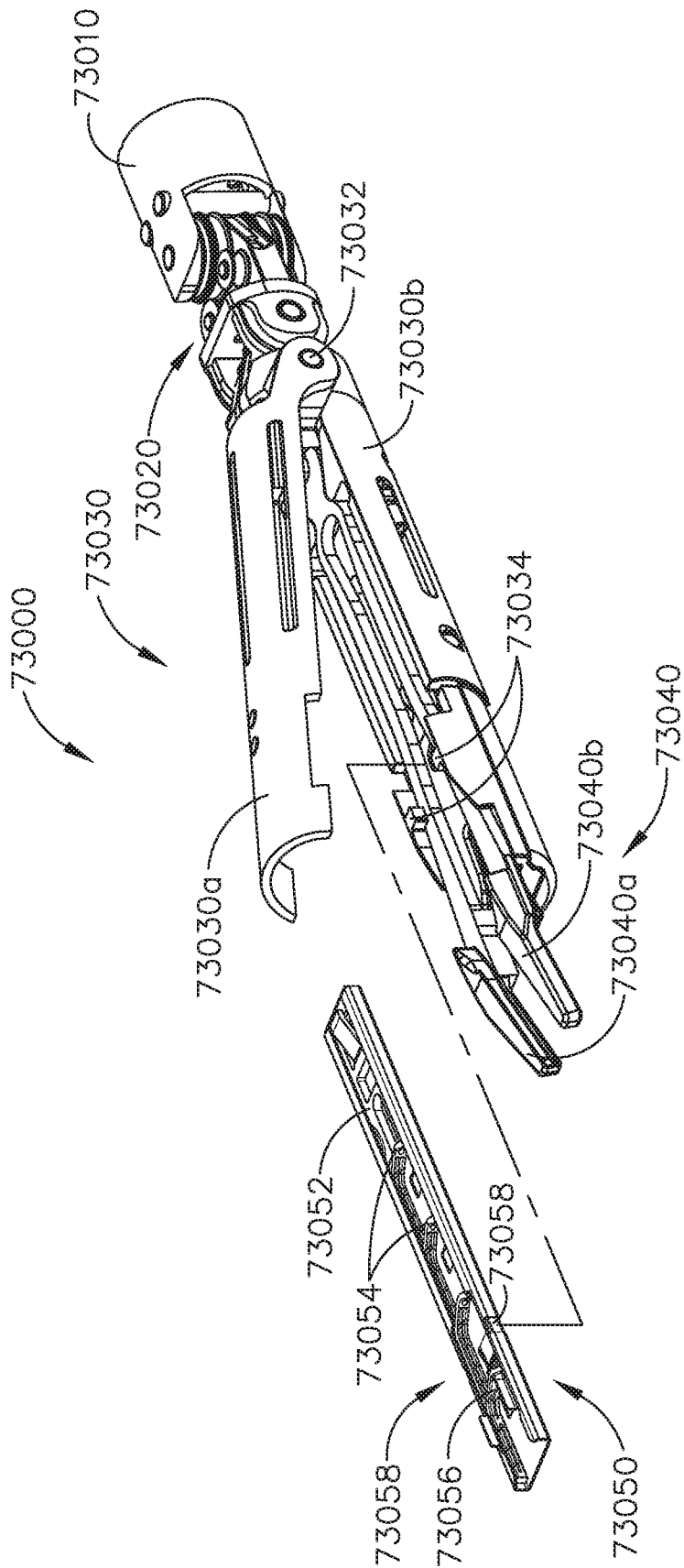

FIG. 87A

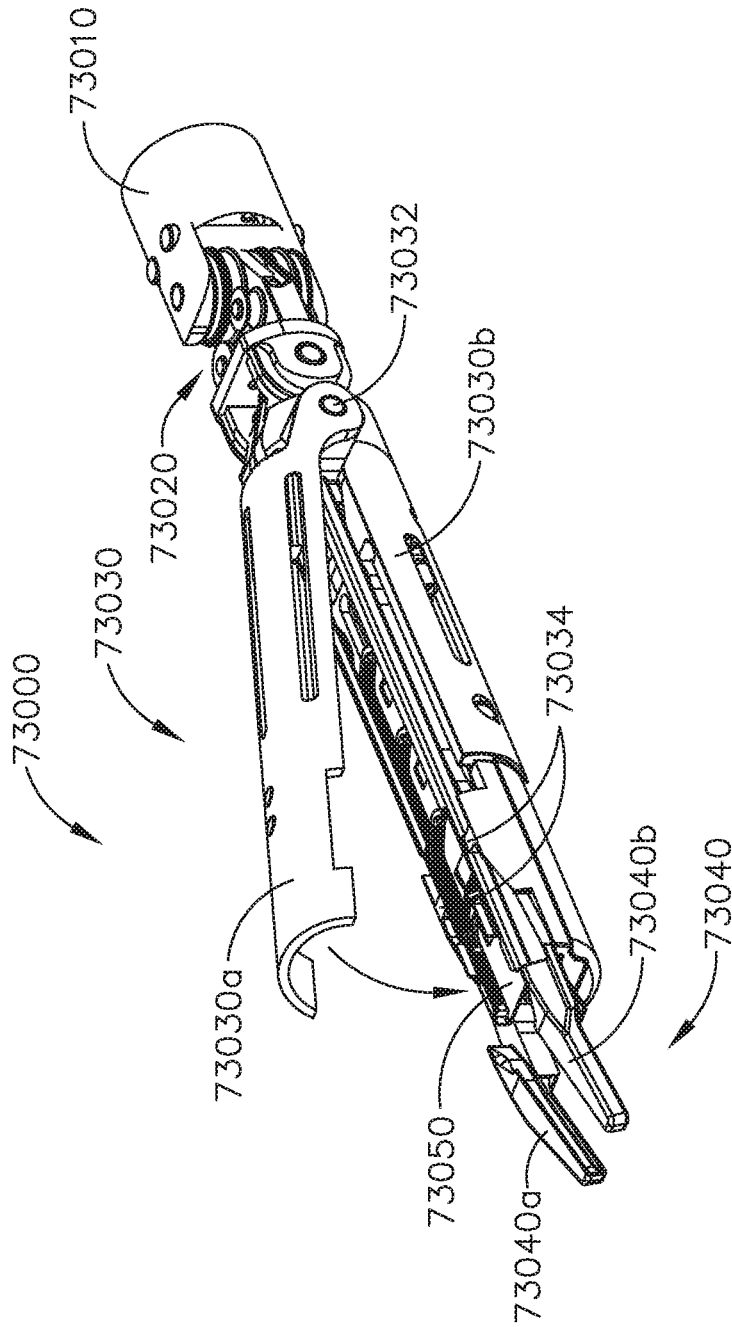

FIG. 87B

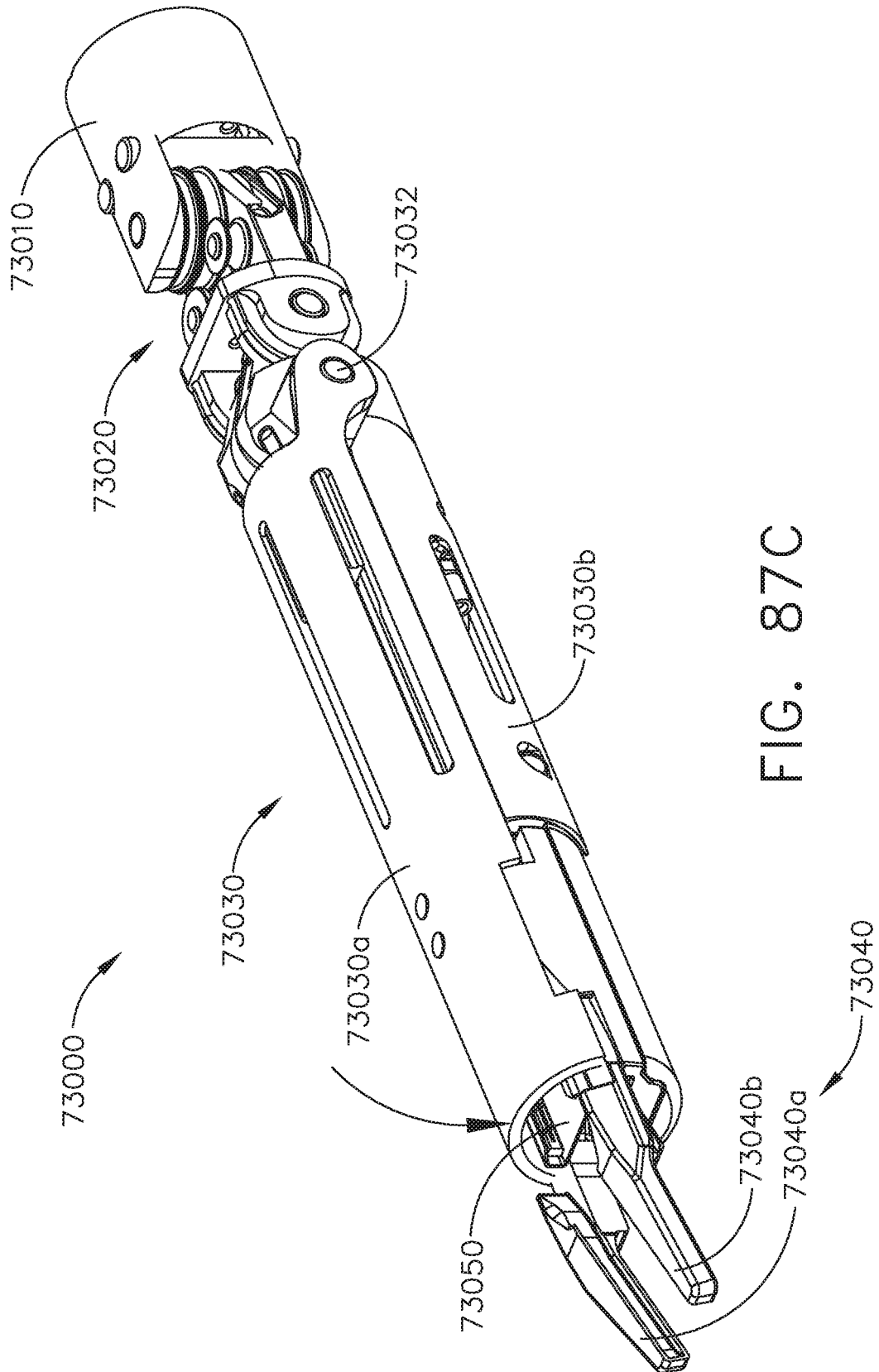

FIG. 87C

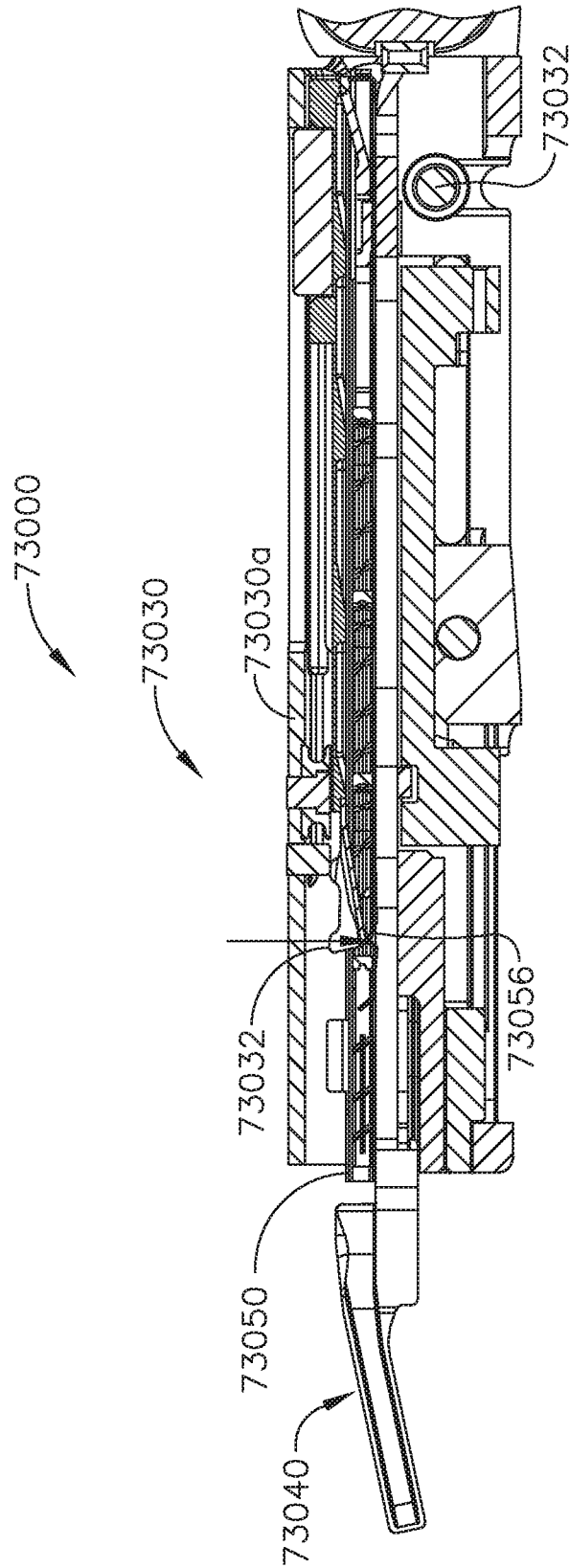

FIG. 87D

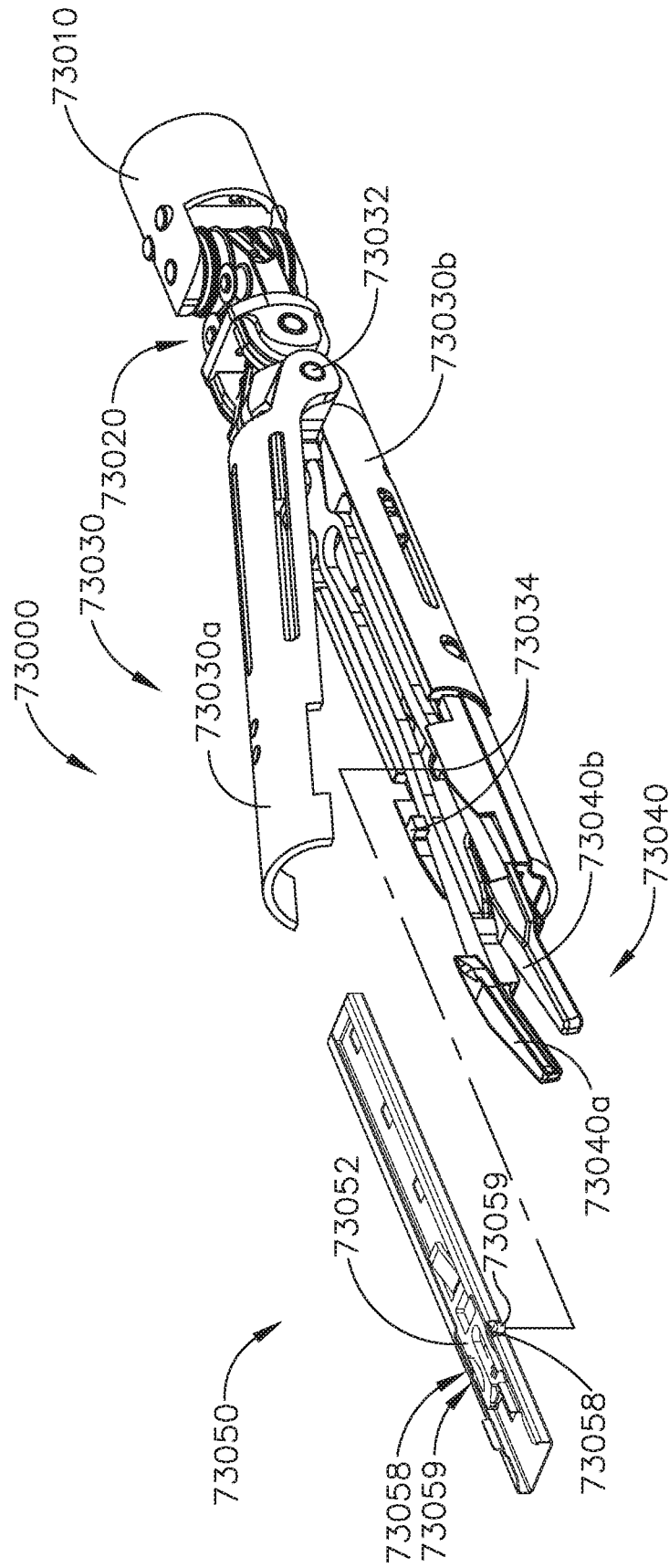

FIG. 88A

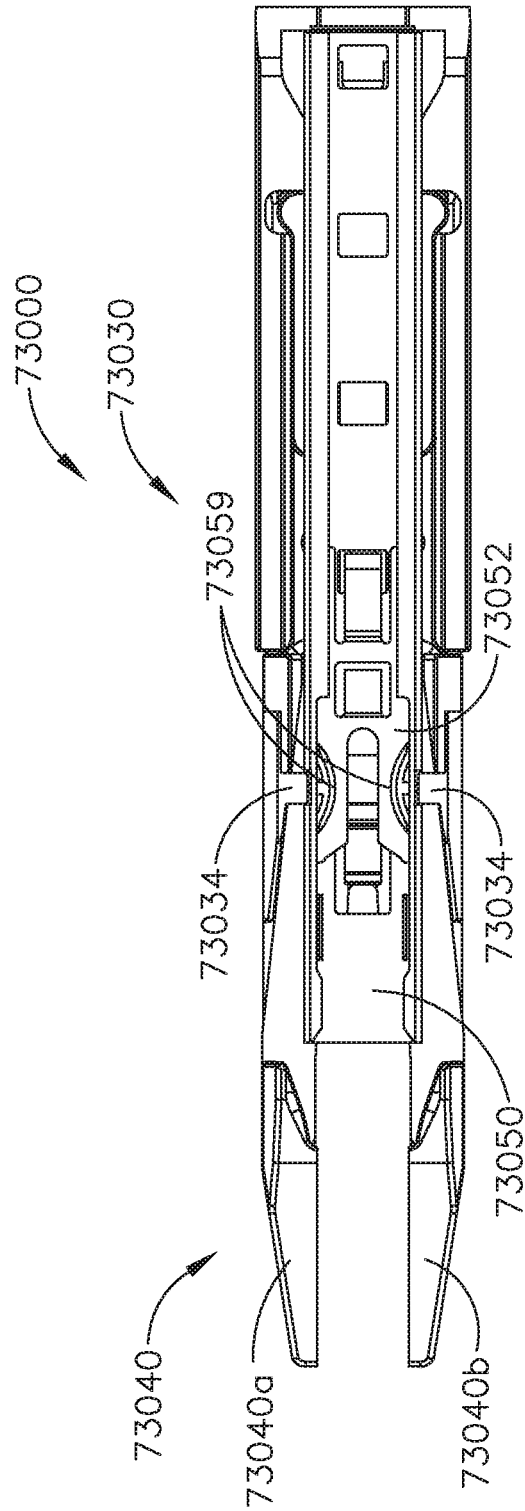

FIG. 88B

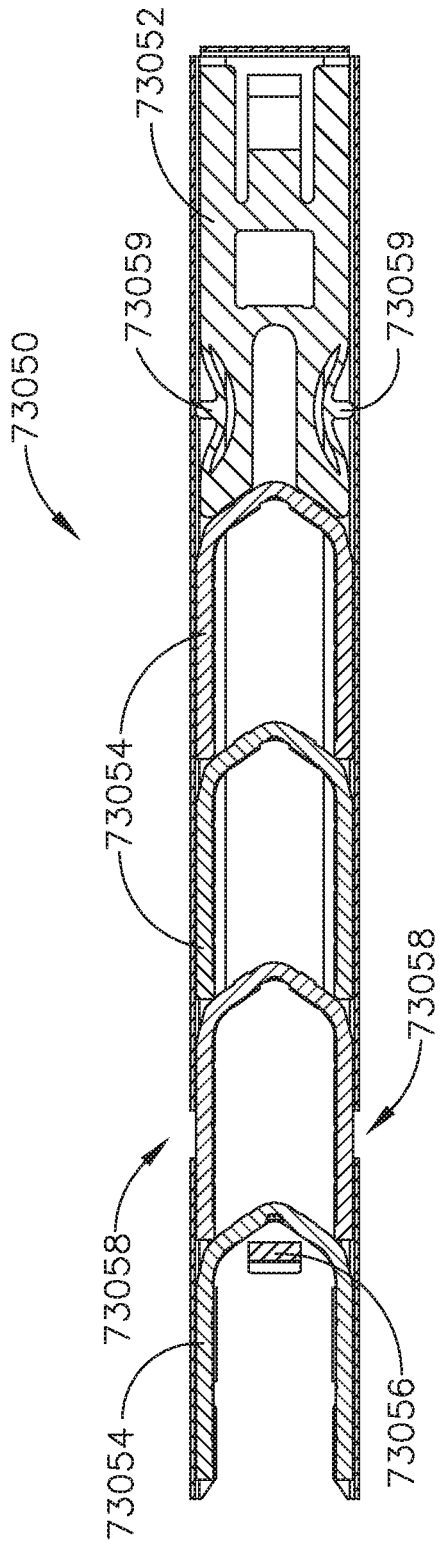

FIG. 88C

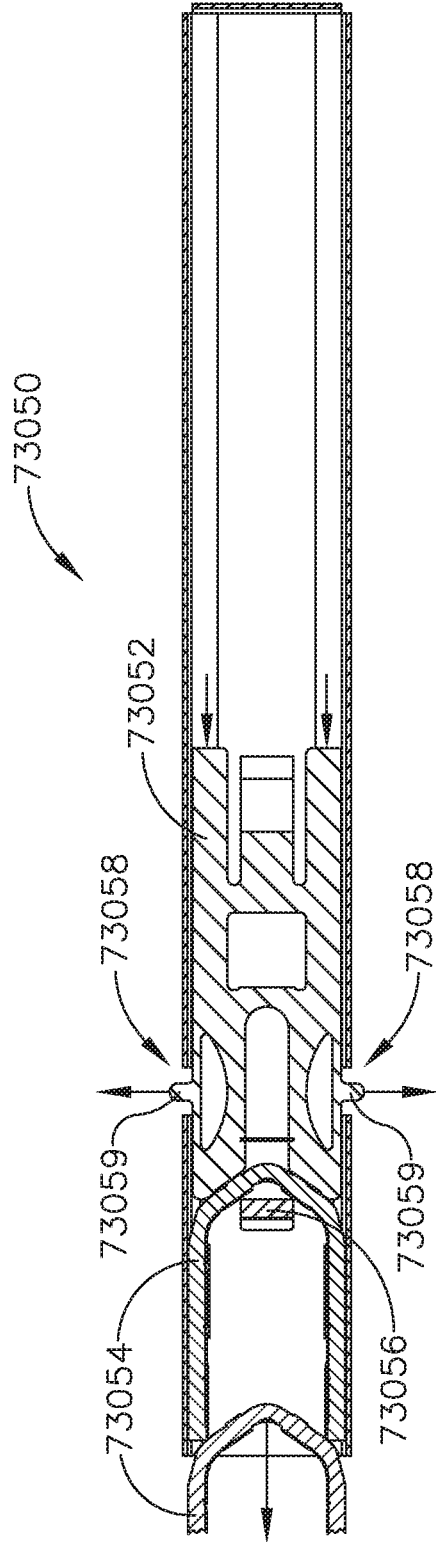

FIG. 88D

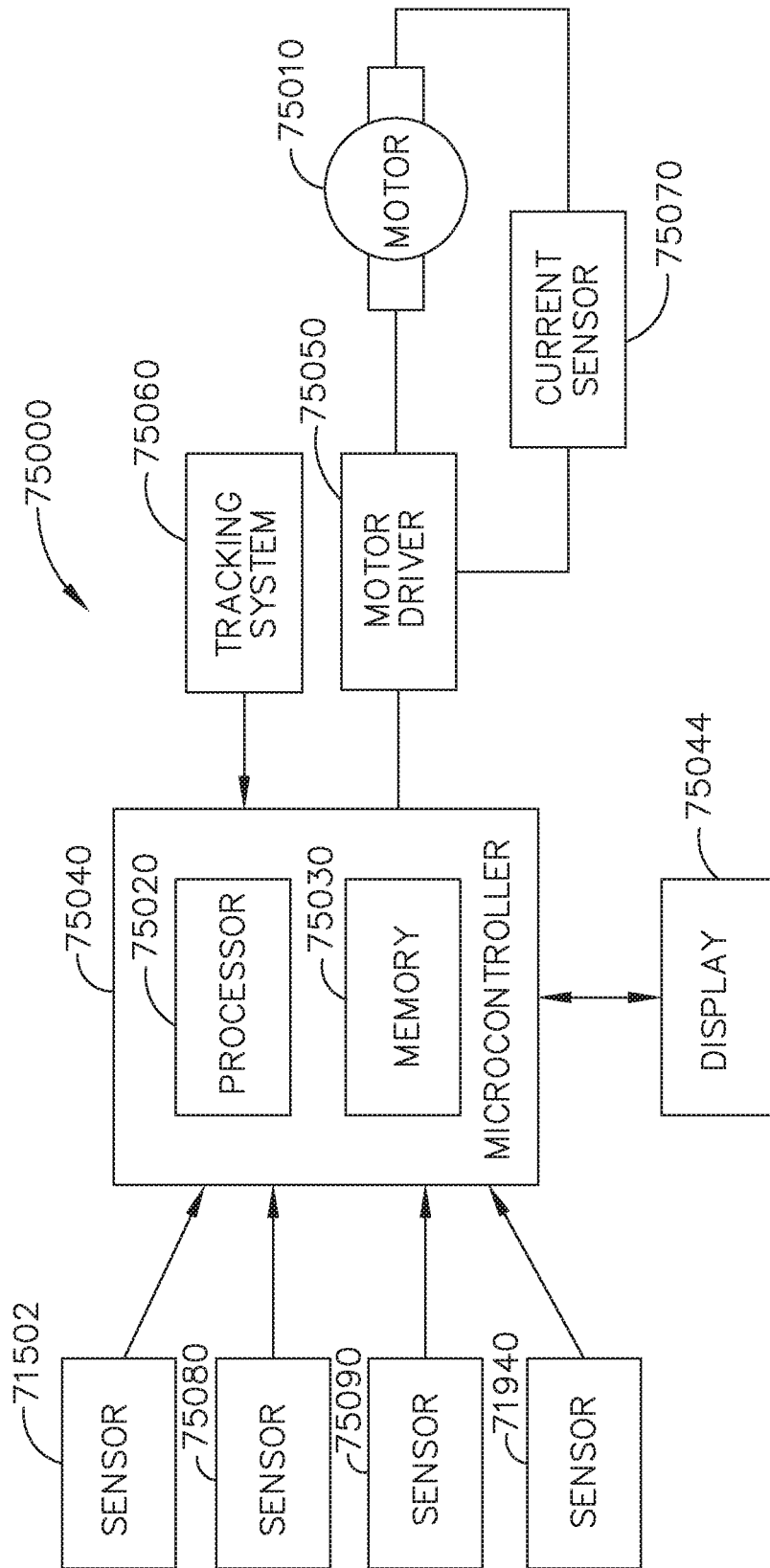

FIG. 89

SURGICAL CLIP APPLIER COMPRISING AN EMPTY CLIP CARTRIDGE LOCKOUT

CROSS-REFERENCE TO RELATED APPLICATIONS

This non-provisional application claims the benefit under 35 U.S.C. § 119(e) of U.S. Provisional Patent Application Ser. No. 62/578,793, entitled SURGICAL INSTRUMENT WITH REMOTE RELEASE, filed Oct. 30, 2017, of U.S. Provisional Patent Application Ser. No. 62/578,804, entitled SURGICAL INSTRUMENT HAVING DUAL ROTATABLE MEMBERS TO EFFECT DIFFERENT TYPES OF END EFFECTOR MOVEMENT, filed Oct. 30, 2017, of U.S. Provisional Patent Application Ser. No. 62/578,817, entitled SURGICAL INSTRUMENT WITH ROTARY DRIVE SELECTIVELY ACTUATING MULTIPLE END EFFECTOR FUNCTIONS, filed Oct. 30, 2017, of U.S. Provisional Patent Application Ser. No. 62/578,835, entitled SURGICAL INSTRUMENT WITH ROTARY DRIVE SELECTIVELY ACTUATING MULTIPLE END EFFECTOR FUNCTIONS, filed Oct. 30, 2017, of U.S. Provisional Patent Application Ser. No. 62/578,844, entitled SURGICAL INSTRUMENT WITH MODULAR POWER SOURCES, filed Oct. 30, 2017, and of U.S. Provisional Patent Application Ser. No. 62/578,855, entitled SURGICAL INSTRUMENT WITH SENSOR AND/OR CONTROL SYSTEMS, filed Oct. 30, 2017, the disclosures of which are incorporated by reference herein in their entirety. This non-provisional application claims the benefit under 35 U.S.C. § 119(e) of U.S. Provisional Patent Application Ser. No. 62/665,129, entitled SURGICAL SUTURING SYSTEMS, filed May 1, 2018, of U.S. Provisional Patent Application Ser. No. 62/665,139, entitled SURGICAL INSTRUMENTS COMPRISING CONTROL SYSTEMS, filed May 1, 2018, of U.S. Provisional Patent Application Ser. No. 62/665,177, entitled SURGICAL INSTRUMENTS COMPRISING HANDLE ARRANGEMENTS, filed May 1, 2018, of U.S. Provisional Patent Application Ser. No. 62/665,128, entitled MODULAR SURGICAL INSTRUMENTS, filed May 1, 2018, of U.S. Provisional Patent Application Ser. No. 62/665,192, entitled SURGICAL DISSECTORS, filed May 1, 2018, and of U.S. Provisional Patent Application Ser. No. 62/665,134, entitled SURGICAL CLIP APPLIER, filed May 1, 2018, the disclosures of which are incorporated by reference herein in their entirety.

BACKGROUND

A variety of fasteners can be utilized to treat, clamp, fasten, secure, and/or hold tissue. Clips can be positioned relative to tissue located within a surgical site in a patient and then deformed to apply a clamping force, for example, to the tissue.

BRIEF DESCRIPTION OF THE DRAWINGS

The features and advantages of this invention, and the manner of attaining them, will become more apparent and the invention itself will be better understood by reference to the following description of exemplary embodiments of the invention taken in conjunction with the accompanying drawings, wherein:

FIG. 1 is a partial perspective view of a clip applier;

FIG. 2 is a cross-sectional view of an end effector of the clip applier of FIG. 1 comprising a removable clip cartridge,

a reciprocating firing drive for sequentially advancing the clips, a receiver for receiving the clips, and a crimping drive for deforming the clips;

FIG. 3 is a partial cross-sectional view of the clip applier of FIG. 1 in an open configuration;

FIG. 4 is a partial cross-sectional view of the clip applier of FIG. 1 in a closed configuration;

FIG. 5 is a cross-sectional view of the end effector of FIG. 2 in an unfired condition;

FIG. 6 is a cross-sectional view of the end effector of FIG. 2 illustrating the firing drive in a partially fired condition in which a firing member of the firing drive has advanced a clip into the receiver;

FIG. 7 is a cross-sectional view of the end effector of FIG. 2 illustrating the firing drive coming into engagement with the crimping drive;

FIG. 8 is a cross-sectional view of the end effector of FIG. 2 illustrating the crimping drive in an at least partially fired condition;

FIG. 9 is a cross-sectional view of the end effector of FIG. 2 illustrating the firing drive becoming disengaged from the firing member;

FIG. 10 is a cross-sectional view of the end effector of FIG. 2 illustrating the crimping drive in its fully fired condition;

FIG. 11 is a cross-sectional view of the firing drive of the end effector of FIG. 2 in a partially retracted position in which the firing drive is being re-engaged with the firing member;

FIG. 12 is a cross-sectional view of the firing drive of the end effector of FIG. 2 being disengaged from the crimping drive;

FIG. 13 is a perspective view of a clip illustrated in FIGS. 2-12;

FIG. 14 is a front view of a cartridge illustrated in FIGS. 1-12 comprising a plurality of clips with portions of the cartridge removed to illustrate the clips stored in the cartridge;

FIG. 15 is a side view of the cartridge of FIG. 14 illustrated with portions removed to illustrate the clips stored in the cartridge;

FIG. 16 is a cross-sectional plan view of the cartridge of FIG. 14 taken along line 16-16 in FIG. 15;

FIG. 17 is a side view of an alternative cartridge usable in connection with the clip applier of FIGS. 1-12 or any other suitable clip applier, wherein the cartridge is illustrated with portions removed to illustrate a biasing member and a pusher plate positioned intermediate the biasing member and the clips contained therein;

FIG. 18 is a side view of a cartridge in accordance with at least one alternative embodiment illustrated with portions removed to illustrate a biasing member and a lockout plate positioned intermediate the biasing member and the clips contained therein;

FIG. 19 is a cross-sectional plan view of the cartridge of FIG. 18 taken along line 19-19 in FIG. 18;

FIG. 20 is a side view of a further alternative cartridge usable in connection with the clip applier of FIGS. 1-12 or any other suitable clip applier, wherein the cartridge can comprise a housing illustrated with portions removed to illustrate a lockout plate comprising guides which are configured to co-operate with guides defined in the cartridge housing;

FIG. 21 is a cross-sectional plan view of the cartridge of FIG. 20 taken along line 21-21 in FIG. 20;

FIG. 22 is an elevational view of a firing drive comprising a rotary input, a rotary output, a firing nut engaged with the

rotary output, and a transmission in a firing configuration in accordance with at least one embodiment;

FIG. 23 is a perspective view of the firing drive of FIG. 22 illustrating the firing nut in an unfired position;

FIG. 24 is a perspective view of the firing drive of FIG. 22 illustrating the firing nut advanced along the rotary output and a cam extending from the firing nut;

FIG. 25 is a perspective view of the firing drive of FIG. 22 illustrating the cam of the firing nut engaged with the transmission of the firing drive and the transmission in a reverse configuration;

FIG. 26 is a perspective view of the firing drive of FIG. 22 illustrating firing nut in a retracted position and a second cam extending from the firing nut engaged with the transmission to shift the transmission from its reverse configuration to its firing configuration;

FIG. 27 is a perspective view of a robotic surgical instrument system operably supporting a plurality of surgical tools usable with the clip applicator of FIGS. 2-12 or any other suitable clip applicator;

FIG. 28 is a perspective view of a surgical tool including an actuator module, a shaft extending from the actuator module, and a replaceable end effector;

FIG. 29 is a perspective view of a handle actuator usable with the clip applicator of FIGS. 2-12 or any other suitable clip applicator;

FIG. 30 is a cross-sectional view of the articulation joint illustrated in FIG. 2;

FIG. 31 is a rear perspective view of an alternative actuator module that may be used in place of the actuator module of FIG. 28 with at least a portion of its housing removed;

FIG. 32 is an exploded view of a portion of the actuator module of FIG. 31;

FIG. 33 is a partial sectional view of the actuator module of FIG. 31;

FIG. 34 is a cross-sectional view of an articulation actuator of the actuator module of FIG. 31;

FIG. 35A is a partial cross-sectional view of an end effector of a clip applicator in a closed configuration;

FIG. 35B is a partial cross-sectional view of the end effector of FIG. 35A in an open configuration;

FIG. 35C is a cross-sectional view of the end effector of FIG. 35A in an open configuration;

FIG. 36 is a partial cross-sectional view of the end effector of FIG. 35A illustrating the position of a stored clip when a crimping drive of the end effector is in a fully fired position;

FIG. 37 is a partial cross-sectional view of the end effector of FIG. 35A illustrating the position of the stored clip when the crimping drive is in a home position;

FIG. 38 is a partial cross-sectional view of the end effector of FIG. 35A illustrating the position of the stored clip when the crimping drive is in a fully retracted position;

FIG. 39 is a partial cross-sectional view of a clip applicator comprising a clip cartridge containing clips having a first size;

FIG. 40 is a partial cross-sectional view of the clip applicator of FIG. 39 comprising a different clip cartridge containing clips having a second size;

FIG. 41 is a partial cross-sectional view of a multi-level clip stack arrangement;

FIG. 42A is a perspective view of a clip applicator comprising an attachment mechanism;

FIG. 42B is a cross-sectional view of the clip applicator of FIG. 42A;

FIG. 43A is a perspective view of a clip applicator comprising a clip magazine;

FIG. 43B is a perspective view of clips for use with the clip applicator of FIG. 43A;

FIG. 44 is a perspective view of a clip reloader for use with a clip applicator comprising a clip magazine;

FIG. 45 is a perspective view of a clip reloader;

FIG. 46 is a cross-sectional view of the clip reloader of FIG. 45;

FIG. 47 is a cross-sectional view of the clip reloader of FIG. 45 and an end effector of a clip applicator;

FIG. 48 is a partial cross-sectional plan view of a clip applicator;

FIG. 49 is a partial cross-sectional side view of the clip applicator of FIG. 48;

FIG. 50 is a perspective view of the clip applicator of FIG. 48;

FIG. 51A is a perspective view of a clip including a flexible base;

FIG. 51B is a side view of the clip of FIG. 51A in various configurations;

FIG. 51C is a perspective view of a clip for use with a clip applicator;

FIG. 51D is a side view of the clip of FIG. 51C in a storage configuration;

FIG. 51E is a side view of the clip of FIG. 51C in a pre-firing configuration;

FIG. 51F is a side view of the clip of FIG. 51C in a post-firing configuration;

FIG. 52 is a perspective view of a clip applicator including a rotatable clip magazine;

FIG. 53 is a partial cross-sectional view of the clip applicator of FIG. 52 illustrating a closure tube of the clip applicator in a fully retracted position;

FIG. 54A is a partial cross-sectional view of the clip applicator of FIG. 52 illustrating the closure tube in a home position;

FIG. 54B is a perspective view of a ground portion including a clocking portion of the clip applicator of FIG. 52;

FIG. 55 is a partial cross-sectional view of the clip applicator of FIG. 52 illustrating clips stored in the rotatable clip magazine prior to being advanced, illustrated with some components removed;

FIG. 56 is a partial cross-sectional view of the clip applicator of FIG. 52 illustrating a clip being advanced from the rotatable clip magazine by a feeder member of the clip applicator;

FIG. 57 is a partial cross-sectional view of the clip applicator of FIG. 52 illustrating the feeder member retracted;

FIG. 58 is a partial cross-sectional view of the clip applicator of FIG. 52 illustrating a closure tube of the clip applicator in a fully retracted position;

FIG. 59 is a partial cross-sectional view of the clip applicator of FIG. 52 illustrating the closure tube in a home position and a firing member advancing a clip, illustrated with some components removed;

FIG. 60 is a partial cross-sectional view of the clip applicator of FIG. 53 illustrating the firing member retracted and the closure tube in a fully advanced position, illustrated with some components removed;

FIG. 61 is a partial cross-sectional view of a clip applicator comprising a replaceable cartridge;

FIG. 62A is a cross-sectional end view of a rotatable clip magazine;

FIG. 62B is a plan view of a clip for use with the rotatable clip magazine of FIG. 62A;

FIG. 63A is a perspective view of a releasable clip cartridge including an articulation joint;

FIG. 63B is a partial cross-sectional view of the releasable clip cartridge and articulation joint of FIG. 63A;

FIG. 64 is a perspective view of a clip applicator including an articulation joint;

FIG. 65 is a partial cross-sectional view of a clip applicator jaw assembly;

FIG. 66A is a partial cross-sectional view of clip applicator jaw assembly including offset support legs;

FIG. 66B is a partial cross-sectional view of the clip applicator jaw assembly of FIG. 66A;

FIG. 67 is a partial cross sectional plan view of the clip applicator jaw assembly of FIG. 65;

FIG. 68 is a partial cross sectional plan view of the clip applicator jaw assembly of FIG. 66A;

FIG. 69 is a graphical depiction of the movements of a cam member and a feeder shoe of a clip applicator throughout the operation of the clip applicator;

FIG. 70 is a graph depicting the displacement of a cam member and feeder shoe of the clip applicator of FIG. 52 as a function of time;

FIG. 71 depicts a first graph illustrating the force to advance a clip of a clip applicator as a function of displacement and a second graph illustrating the voltage of a motor of the clip applicator as a function of time;

FIG. 72 depicts a graph of the force applied to a pair of jaws of a clip applicator versus time;

FIG. 73 is directed to an alternative embodiment;

FIG. 74 is directed to an alternative embodiment;

FIG. 75 is a perspective view of a clip applicator including a rotating clip magazine, a magnet, and a Hall Effect sensor;

FIG. 76 is a graphical depiction of the clip applicator of FIG. 75 illustrating the voltage of the Hall Effect sensor as a function of the position of the magnet over time;

FIG. 77 is a partial cross-sectional view of a clip applicator including resistive sensing circuits;

FIG. 78A is a partial cross-sectional view of a clip applicator including a variable resistance meter;

FIG. 78B is a partial cross-sectional view of the clip applicator of FIG. 78A in a partially crimped configuration;

FIG. 79 is a perspective view of a clip applicator jaw including strain gauges;

FIG. 80 is a graphical depiction of the clip applicator jaw of FIG. 79 illustrating the voltage of the strain gauges as a function of time;

FIG. 81A is a partial cross-sectional view of a clip applicator including a sensor array and a magnet;

FIG. 81B is a partial cross-sectional view of the clip applicator of FIG. 81A;

FIG. 82 is a perspective view of a clip applicator system utilizing a trocar;

FIG. 83 is a perspective view of the clip applicator system of FIG. 82;

FIG. 84A is a partial side elevation view of the clip applicator system of FIG. 82 depicting a jaw wing of a clip applicator of the clip applicator system positioned distal to a loading arm of a clip magazine of the clip applicator system;

FIG. 84B is a partial side elevation view of the clip applicator system of FIG. 82 depicting the jaw wing of the clip applicator positioned proximal to the loading arm of the clip magazine;

FIG. 84C is a partial side elevation view of the clip applicator system of FIG. 82 depicting the jaw wing of the clip applicator positioned proximal to the loading arm of the clip magazine;

FIG. 85A is a partial perspective view of the clip applicator system of FIG. 82;

FIG. 85B is a cross-sectional perspective view of the clip applicator system of FIG. 82;

FIG. 86A is a plan view of the clip applicator system of FIG. 82 depicting a jaw wing of the clip applicator in an expanded configuration;

FIG. 86B is a plan view of the clip applicator system of FIG. 82 depicting the jaw wing of the clip applicator in a retracted configuration;

FIG. 87A is a perspective view of a clip applicator and a clip magazine for use with the clip applicator;

FIG. 87B is a perspective view of the clip magazine seated into the clip applicator of FIG. 87A;

FIG. 87C is a perspective view of the clip applicator and the clip magazine of FIG. 87A in a loaded configuration;

FIG. 87D is a cross-sectional view of the clip applicator and the clip magazine of FIG. 87A in the loaded configuration of FIG. 87C;

FIG. 88A is a perspective view the spent clip magazine removed from the clip applicator of FIG. 87A;

FIG. 88B is a plan view of the spent clip magazine seated into the clip applicator of FIG. 87A;

FIG. 88C is a cross-sectional plan view of the clip applicator and the clip magazine of FIG. 87A;

FIG. 88D is a cross-sectional plan view of the clip applicator and the clip magazine of FIG. 87A in a nearly spent configuration; and

FIG. 89 is a schematic of a control system for use with any of the surgical instruments disclosed herein.

DETAILED DESCRIPTION

Applicant of the present application owns the following U.S. Patent Applications that were filed on Aug. 24, 2018 and which are each herein incorporated by reference in their respective entireties:

U.S. patent application Ser. No. 16/112,129, entitled SURGICAL SUTURING INSTRUMENT CONFIGURED TO MANIPULATE TISSUE USING MECHANICAL AND ELECTRICAL POWER; now U.S. Patent Application Publication No. 2019/0125431;

U.S. patent application Ser. No. 16/112,155, entitled SURGICAL SUTURING INSTRUMENT COMPRISING A CAPTURE WIDTH WHICH IS LARGER THAN TROCAR DIAMETER; now U.S. Patent Application Publication No. 2019/0125335;

U.S. patent application Ser. No. 16/112,168, entitled SURGICAL SUTURING INSTRUMENT COMPRISING A NON-CIRCULAR NEEDLE; now U.S. Patent Application Publication No. 2019/0125336;

U.S. patent application Ser. No. 16/112,180, entitled ELECTRICAL POWER OUTPUT CONTROL BASED ON MECHANICAL FORCES; now U.S. Patent Application Publication No. 2019/0125432;

U.S. patent application Ser. No. 16/112,193, entitled REACTIVE ALGORITHM FOR SURGICAL SYSTEM; now U.S. Pat. No. 10,932,806;

U.S. patent application Ser. No. 16/112,099, entitled SURGICAL INSTRUMENT COMPRISING AN ADAPTIVE ELECTRICAL SYSTEM; now U.S. Patent Application Publication No. 2019/0125378;

U.S. patent application Ser. No. 16/112,112, entitled CONTROL SYSTEM ARRANGEMENTS FOR A MODULAR SURGICAL INSTRUMENT; now U.S. Patent Application Publication No. 2019/0125320;

U.S. patent application Ser. No. 16/112,119, entitled ADAPTIVE CONTROL PROGRAMS FOR A SURGICAL SYSTEM COMPRISING MORE THAN ONE

TYPE OF CARTRIDGE; now U.S. Patent Application Publication No. 2019/0125338;

U.S. patent application Ser. No. 16/112,097, entitled SURGICAL INSTRUMENT SYSTEMS COMPRISING BATTERY ARRANGEMENTS; now U.S. Patent Application Publication No. 2019/0125377;

U.S. patent application Ser. No. 16/112,109, entitled SURGICAL INSTRUMENT SYSTEMS COMPRISING HANDLE ARRANGEMENTS; now U.S. Patent Application Publication No. 2019/0125388;

U.S. patent application Ser. No. 16/112,114, entitled SURGICAL INSTRUMENT SYSTEMS COMPRISING FEEDBACK MECHANISMS; now U.S. Patent Application Publication No. 2019/0142449;

U.S. patent application Ser. No. 16/112,117, entitled SURGICAL INSTRUMENT SYSTEMS COMPRISING LOCKOUT MECHANISMS; now U.S. Patent Application Publication No. 2019/0125476;

U.S. patent application Ser. No. 16/112,095, entitled SURGICAL INSTRUMENTS COMPRISING A LOCKABLE END EFFECTOR SOCKET; now U.S. Patent Application Publication No. 2019/0125387;

U.S. patent application Ser. No. 16/112,121, entitled SURGICAL INSTRUMENTS COMPRISING A SHIFTING MECHANISM; now U.S. Patent Application Publication No. 2019/0125389;

U.S. patent application Ser. No. 16/112,151, entitled SURGICAL INSTRUMENTS COMPRISING A SYSTEM FOR ARTICULATION AND ROTATION COMPENSATION; now U.S. Pat. No. 10,772,651;

U.S. patent application Ser. No. 16/112,154, entitled SURGICAL INSTRUMENTS COMPRISING A BIASED SHIFTING MECHANISM; now U.S. Patent Application Publication No. 2019/0125321;

U.S. patent application Ser. No. 16/112,226, entitled SURGICAL INSTRUMENTS COMPRISING AN ARTICULATION DRIVE THAT PROVIDES FOR HIGH ARTICULATION ANGLES; now U.S. Patent Application Publication No. 2019/0125379;

U.S. patent application Ser. No. 16/112,062, entitled SURGICAL DISSECTORS AND MANUFACTURING TECHNIQUES; now U.S. Patent Application Publication No. 2019/0125386;

U.S. patent application Ser. No. 16/112,098, entitled SURGICAL DISSECTORS CONFIGURED TO APPLY MECHANICAL AND ELECTRICAL ENERGY; now U.S. Patent Application Publication No. 2019/0125430;

U.S. patent application Ser. No. 16/112,237, entitled SURGICAL CLIP APPLIER CONFIGURED TO STORE CLIPS IN A STORED STATE; now U.S. Patent Application Publication No. 2019/0125347;

U.S. patent application Ser. No. 16/112,249, entitled SURGICAL CLIP APPLIER COMPRISING AN AUTOMATIC CLIP FEEDING SYSTEM; now U.S. Patent Application Publication No. 2019/0125353;

U.S. patent application Ser. No. 16/112,253, entitled SURGICAL CLIP APPLIER COMPRISING ADAPTIVE FIRING CONTROL; now U.S. Patent Application Publication No. 2019/0125348; and

U.S. patent application Ser. No. 16/112,257, entitled SURGICAL CLIP APPLIER COMPRISING ADAPTIVE CONTROL IN RESPONSE TO A STRAIN GAUGE CIRCUIT; now U.S. Patent Application Publication No. 2019/0125354.

Applicant of the present application owns the following U.S. Patent Applications that were filed on May 1, 2018 and which are each herein incorporated by reference in their respective entireties:

U.S. Provisional Patent Application Ser. No. 62/665,129, entitled SURGICAL SUTURING SYSTEMS;

U.S. Provisional Patent Application Ser. No. 62/665,139, entitled SURGICAL INSTRUMENTS COMPRISING CONTROL SYSTEMS;

U.S. Provisional Patent Application Ser. No. 62/665,177, entitled SURGICAL INSTRUMENTS COMPRISING HANDLE ARRANGEMENTS;

U.S. Provisional Patent Application Ser. No. 62/665,128, entitled MODULAR SURGICAL INSTRUMENTS;

U.S. Provisional Patent Application Ser. No. 62/665,192, entitled SURGICAL DISSECTORS; and

U.S. Provisional Patent Application Ser. No. 62/665,134, entitled SURGICAL CLIP APPLIER.

Applicant of the present application owns the following U.S. Patent Applications that were filed on Feb. 28, 2018 and which are each herein incorporated by reference in their respective entireties:

U.S. patent application Ser. No. 15/908,021, entitled SURGICAL INSTRUMENT WITH REMOTE RELEASE;

U.S. patent application Ser. No. 15/908,012, entitled SURGICAL INSTRUMENT HAVING DUAL ROTATABLE MEMBERS TO EFFECT DIFFERENT TYPES OF END EFFECTOR MOVEMENT;

U.S. patent application Ser. No. 15/908,040, entitled SURGICAL INSTRUMENT WITH ROTARY DRIVE SELECTIVELY ACTUATING MULTIPLE END EFFECTOR FUNCTIONS;

U.S. patent application Ser. No. 15/908,057, entitled SURGICAL INSTRUMENT WITH ROTARY DRIVE SELECTIVELY ACTUATING MULTIPLE END EFFECTOR FUNCTIONS;

U.S. patent application Ser. No. 15/908,058, entitled SURGICAL INSTRUMENT WITH MODULAR POWER SOURCES; and

U.S. patent application Ser. No. 15/908,143, entitled SURGICAL INSTRUMENT WITH SENSOR AND/OR CONTROL SYSTEMS.

Applicant of the present application owns the following U.S. Patent Applications that were filed on Oct. 30, 2017 and which are each herein incorporated by reference in their respective entireties:

U.S. Provisional Patent Application Ser. No. 62/578,793, entitled SURGICAL INSTRUMENT WITH REMOTE RELEASE;

U.S. Provisional Patent Application Ser. No. 62/578,804, entitled SURGICAL INSTRUMENT HAVING DUAL ROTATABLE MEMBERS TO EFFECT DIFFERENT TYPES OF END EFFECTOR MOVEMENT;

U.S. Provisional Patent Application Ser. No. 62/578,817, entitled SURGICAL INSTRUMENT WITH ROTARY DRIVE SELECTIVELY ACTUATING MULTIPLE END EFFECTOR FUNCTIONS;

U.S. Provisional Patent Application Ser. No. 62/578,835, entitled SURGICAL INSTRUMENT WITH ROTARY DRIVE SELECTIVELY ACTUATING MULTIPLE END EFFECTOR FUNCTIONS;

U.S. Provisional Patent Application Ser. No. 62/578,844, entitled SURGICAL INSTRUMENT WITH MODULAR POWER SOURCES; and

U.S. Provisional Patent Application Ser. No. 62/578,855, entitled SURGICAL INSTRUMENT WITH SENSOR AND/OR CONTROL SYSTEMS.

Applicant of the present application owns the following U.S. Provisional Patent Applications, filed on Dec. 28, 2017, the disclosure of each of which is herein incorporated by reference in its entirety:

U.S. Provisional Patent Application Ser. No. 62/611,341, entitled INTERACTIVE SURGICAL PLATFORM;

U.S. Provisional Patent Application Ser. No. 62/611,340, entitled CLOUD-BASED MEDICAL ANALYTICS; and

U.S. Provisional Patent Application Ser. No. 62/611,339, entitled ROBOT ASSISTED SURGICAL PLATFORM.

Applicant of the present application owns the following U.S. Provisional Patent Applications, filed on Mar. 28, 2018, each of which is herein incorporated by reference in its entirety:

U.S. Provisional Patent Application Ser. No. 62/649,302, entitled INTERACTIVE SURGICAL SYSTEMS WITH ENCRYPTED COMMUNICATION CAPABILITIES;

U.S. Provisional Patent Application Ser. No. 62/649,294, entitled DATA STRIPPING METHOD TO INTERROGATE PATIENT RECORDS AND CREATE ANONYMIZED RECORD;

U.S. Provisional Patent Application Ser. No. 62/649,300, entitled SURGICAL HUB SITUATIONAL AWARENESS;

U.S. Provisional Patent Application Ser. No. 62/649,309, entitled SURGICAL HUB SPATIAL AWARENESS TO DETERMINE DEVICES IN OPERATING THEATER;

U.S. Provisional Patent Application Ser. No. 62/649,310, entitled COMPUTER IMPLEMENTED INTERACTIVE SURGICAL SYSTEMS;

U.S. Provisional Patent Application Ser. No. 62/649,291, entitled USE OF LASER LIGHT AND RED-GREEN-BLUE COLORATION TO DETERMINE PROPERTIES OF BACK SCATTERED LIGHT;

U.S. Provisional Patent Application Ser. No. 62/649,296, entitled ADAPTIVE CONTROL PROGRAM UPDATES FOR SURGICAL DEVICES;

U.S. Provisional Patent Application Ser. No. 62/649,333, entitled CLOUD-BASED MEDICAL ANALYTICS FOR CUSTOMIZATION AND RECOMMENDATIONS TO A USER;

U.S. Provisional Patent Application Ser. No. 62/649,327, entitled CLOUD-BASED MEDICAL ANALYTICS FOR SECURITY AND AUTHENTICATION TRENDS AND REACTIVE MEASURES;

U.S. Provisional Patent Application Ser. No. 62/649,315, entitled DATA HANDLING AND PRIORITIZATION IN A CLOUD ANALYTICS NETWORK;

U.S. Provisional Patent Application Ser. No. 62/649,313, entitled CLOUD INTERFACE FOR COUPLED SURGICAL DEVICES;

U.S. Provisional Patent Application Ser. No. 62/649,320, entitled DRIVE ARRANGEMENTS FOR ROBOT-ASSISTED SURGICAL PLATFORMS;

U.S. Provisional Patent Application Ser. No. 62/649,307, entitled AUTOMATIC TOOL ADJUSTMENTS FOR ROBOT-ASSISTED SURGICAL PLATFORMS; and

U.S. Provisional Patent Application Ser. No. 62/649,323, entitled SENSING ARRANGEMENTS FOR ROBOT-ASSISTED SURGICAL PLATFORMS.

Applicant of the present application owns the following U.S. Patent Applications, filed on Mar. 29, 2018, each of which is herein incorporated by reference in its entirety:

U.S. patent application Ser. No. 15/940,641, entitled INTERACTIVE SURGICAL SYSTEMS WITH ENCRYPTED COMMUNICATION CAPABILITIES;

U.S. patent application Ser. No. 15/940,648, entitled INTERACTIVE SURGICAL SYSTEMS WITH CONDITION HANDLING OF DEVICES AND DATA CAPABILITIES;

U.S. patent application Ser. No. 15/940,656, entitled SURGICAL HUB COORDINATION OF CONTROL AND COMMUNICATION OF OPERATING ROOM DEVICES;

U.S. patent application Ser. No. 15/940,666, entitled SPATIAL AWARENESS OF SURGICAL HUBS IN OPERATING ROOMS;

U.S. patent application Ser. No. 15/940,670, entitled COOPERATIVE UTILIZATION OF DATA DERIVED FROM SECONDARY SOURCES BY INTELLIGENT SURGICAL HUBS;

U.S. patent application Ser. No. 15/940,677, entitled SURGICAL HUB CONTROL ARRANGEMENTS;

U.S. patent application Ser. No. 15/940,632, entitled DATA STRIPPING METHOD TO INTERROGATE PATIENT RECORDS AND CREATE ANONYMIZED RECORD;

U.S. patent application Ser. No. 15/940,640, entitled COMMUNICATION HUB AND STORAGE DEVICE FOR STORING PARAMETERS AND STATUS OF A SURGICAL DEVICE TO BE SHARED WITH CLOUD BASED ANALYTICS SYSTEMS;

U.S. patent application Ser. No. 15/940,645, entitled SELF DESCRIBING DATA PACKETS GENERATED AT AN ISSUING INSTRUMENT;

U.S. patent application Ser. No. 15/940,649, entitled DATA PAIRING TO INTERCONNECT A DEVICE MEASURED PARAMETER WITH AN OUTCOME;

U.S. patent application Ser. No. 15/940,654, entitled SURGICAL HUB SITUATIONAL AWARENESS;

U.S. patent application Ser. No. 15/940,663, entitled SURGICAL SYSTEM DISTRIBUTED PROCESSING;

U.S. patent application Ser. No. 15/940,668, entitled AGGREGATION AND REPORTING OF SURGICAL HUB DATA;

U.S. patent application Ser. No. 15/940,671, entitled SURGICAL HUB SPATIAL AWARENESS TO DETERMINE DEVICES IN OPERATING THEATER;

U.S. patent application Ser. No. 15/940,686, entitled DISPLAY OF ALIGNMENT OF STAPLE CARTRIDGE TO PRIOR LINEAR STAPLE LINE;

U.S. patent application Ser. No. 15/940,700, entitled STERILE FIELD INTERACTIVE CONTROL DISPLAYS;

U.S. patent application Ser. No. 15/940,629, entitled COMPUTER IMPLEMENTED INTERACTIVE SURGICAL SYSTEMS;

U.S. patent application Ser. No. 15/940,704, entitled USE OF LASER LIGHT AND RED-GREEN-BLUE COLORATION TO DETERMINE PROPERTIES OF BACK SCATTERED LIGHT;

U.S. patent application Ser. No. 15/940,722, entitled CHARACTERIZATION OF TISSUE IRREGULARITIES THROUGH THE USE OF MONO-CHROMATIC LIGHT REFRACTIVITY; and

U.S. patent application Ser. No. 15/940,742, entitled DUAL CMOS ARRAY IMAGING.

Applicant of the present application owns the following U.S. Patent Applications, filed on Mar. 29, 2018, each of which is herein incorporated by reference in its entirety:

U.S. patent application Ser. No. 15/940,636, entitled ADAPTIVE CONTROL PROGRAM UPDATES FOR SURGICAL DEVICES;

U.S. patent application Ser. No. 15/940,653, entitled ADAPTIVE CONTROL PROGRAM UPDATES FOR SURGICAL HUBS;

U.S. patent application Ser. No. 15/940,660, entitled CLOUD-BASED MEDICAL ANALYTICS FOR CUSTOMIZATION AND RECOMMENDATIONS TO A USER;

U.S. patent application Ser. No. 15/940,679, entitled CLOUD-BASED MEDICAL ANALYTICS FOR LINKING OF LOCAL USAGE TRENDS WITH THE RESOURCE ACQUISITION BEHAVIORS OF LARGER DATA SET;

U.S. patent application Ser. No. 15/940,694, entitled CLOUD-BASED MEDICAL ANALYTICS FOR MEDICAL FACILITY SEGMENTED INDIVIDUALIZATION OF INSTRUMENT FUNCTION;

U.S. patent application Ser. No. 15/940,634, entitled CLOUD-BASED MEDICAL ANALYTICS FOR SECURITY AND AUTHENTICATION TRENDS AND REACTIVE MEASURES;

U.S. patent application Ser. No. 15/940,706, entitled DATA HANDLING AND PRIORITIZATION IN A CLOUD ANALYTICS NETWORK; and

U.S. patent application Ser. No. 15/940,675, entitled CLOUD INTERFACE FOR COUPLED SURGICAL DEVICES.

Applicant of the present application owns the following U.S. Patent Applications, filed on Mar. 29, 2018, each of which is herein incorporated by reference in its entirety:

U.S. patent application Ser. No. 15/940,627, entitled DRIVE ARRANGEMENTS FOR ROBOT-ASSISTED SURGICAL PLATFORMS;

U.S. patent application Ser. No. 15/940,637, entitled COMMUNICATION ARRANGEMENTS FOR ROBOT-ASSISTED SURGICAL PLATFORMS;

U.S. patent application Ser. No. 15/940,642, entitled CONTROLS FOR ROBOT-ASSISTED SURGICAL PLATFORMS;

U.S. patent application Ser. No. 15/940,676, entitled AUTOMATIC TOOL ADJUSTMENTS FOR ROBOT-ASSISTED SURGICAL PLATFORMS;

U.S. patent application Ser. No. 15/940,680, entitled CONTROLLERS FOR ROBOT-ASSISTED SURGICAL PLATFORMS;

U.S. patent application Ser. No. 15/940,683, entitled COOPERATIVE SURGICAL ACTIONS FOR ROBOT-ASSISTED SURGICAL PLATFORMS;

U.S. patent application Ser. No. 15/940,690, entitled DISPLAY ARRANGEMENTS FOR ROBOT-ASSISTED SURGICAL PLATFORMS; and

U.S. patent application Ser. No. 15/940,711, entitled SENSING ARRANGEMENTS FOR ROBOT-ASSISTED SURGICAL PLATFORMS.

Applicant of the present application owns the following U.S. Provisional Patent Applications, filed on Mar. 30, 2018,

each of which is herein incorporated by reference in its entirety:

U.S. Provisional Patent Application Ser. No. 62/650,887, entitled SURGICAL SYSTEMS WITH OPTIMIZED SENSING CAPABILITIES;

U.S. Provisional Patent Application Ser. No. 62/650,877, entitled SURGICAL SMOKE EVACUATION SENSING AND CONTROLS;

U.S. Provisional Patent Application Ser. No. 62/650,882, entitled SMOKE EVACUATION MODULE FOR INTERACTIVE SURGICAL PLATFORM; and

U.S. Provisional Patent Application Ser. No. 62/650,898, entitled CAPACITIVE COUPLED RETURN PATH PAD WITH SEPARABLE ARRAY ELEMENTS.

Applicant of the present application owns the following U.S. Provisional Patent Application, filed on Apr. 19, 2018, which is herein incorporated by reference in its entirety:

U.S. Provisional Patent Application Ser. No. 62/659,900, entitled METHOD OF HUB COMMUNICATION.

Numerous specific details are set forth to provide a thorough understanding of the overall structure, function, manufacture, and use of the embodiments as described in the specification and illustrated in the accompanying drawings. Well-known operations, components, and elements have not been described in detail so as not to obscure the embodiments described in the specification. The reader will understand that the embodiments described and illustrated herein are non-limiting examples, and thus it can be appreciated that the specific structural and functional details disclosed herein may be representative and illustrative. Variations and changes thereto may be made without departing from the scope of the claims.

The terms “comprise” (and any form of comprise, such as “comprises” and “comprising”), “have” (and any form of have, such as “has” and “having”), “include” (and any form of include, such as “includes” and “including”), and “contain” (and any form of contain, such as “contains” and “containing”) are open-ended linking verbs. As a result, a surgical system, device, or apparatus that “comprises,” “has,” “includes,” or “contains” one or more elements possesses those one or more elements, but is not limited to possessing only those one or more elements. Likewise, an element of a system, device, or apparatus that “comprises,” “has,” “includes,” or “contains” one or more features possesses those one or more features, but is not limited to possessing only those one or more features.

The terms “proximal” and “distal” are used herein with reference to a clinician manipulating the handle portion of the surgical instrument. The term “proximal” refers to the portion closest to the clinician and the term “distal” refers to the portion located away from the clinician. It will be further appreciated that, for convenience and clarity, spatial terms such as “vertical,” “horizontal,” “up,” and “down” may be used herein with respect to the drawings. However, surgical instruments are used in many orientations and positions, and these terms are not intended to be limiting and/or absolute.

Various exemplary devices and methods are provided for performing laparoscopic and minimally invasive surgical procedures. However, the reader will readily appreciate that the various methods and devices disclosed herein can be used in numerous surgical procedures and applications including, for example, in connection with open surgical procedures. As the present Detailed Description proceeds, the reader will further appreciate that the various instruments disclosed herein can be inserted into a body in any way, such as through a natural orifice, through an incision or puncture hole formed in tissue, etc. The working portions or

13

end effector portions of the instruments can be inserted directly into a patient's body or can be inserted through an access device that has a working channel through which the end effector and elongate shaft of a surgical instrument can be advanced.

During various surgical procedures, a surgeon, or other clinician, may apply a clip to a patient's tissue in order to achieve various effects and/or therapeutic results. Referring to FIG. 1, a surgical instrument, such as a clip applicator 100, for example, can be configured to apply one or more clips to tissue located within a surgical site in the patient. Generally, referring now to FIG. 13, the clip applicator 100 can be structured and arranged to position a clip 140 relative to the tissue in order to compress the tissue within the clip 140. The clip applicator 100 can be configured to deform the clip 140 as illustrated in FIGS. 3 and 4, for example, and as described in greater detail further below. Each clip 140 can comprise a base 142 and opposing legs 144 extending from the base 142. The base 142 and the legs 144 can comprise any suitable shape and can define a substantially U-shaped configuration and/or a substantially V-shaped configuration, for example. The base 142 can comprise angled portions 141 which are connected together by a joint 143. In use, the legs 144 of the clip 140 can be positioned on opposite sides of the tissue wherein the legs 144 can be pushed toward one another to compress the tissue positioned between the legs 144. The joint 143 can be configured to permit the angled portions 141 of the base 142, and the legs 144 extending therefrom, to deform inwardly. In various circumstances, the clip 140 can be configured to yield, or deform plastically, when the clip 140 is sufficiently compressed, although some amount of elastic deformation, or spring-back, may occur within the deformed clip 140.

Referring now to FIGS. 1 and 2, the clip applicator 100 can include a shaft 110, an end effector 120, and a replaceable clip cartridge, or magazine, 130. Referring to FIGS. 14-16, the clip cartridge 130 can comprise a housing 132 and a plurality of clips 140 positioned within the housing 132. The housing 132 can define a storage chamber 134 in which the clips 140 can be stacked. The storage chamber 134 can comprise sidewalls which extend around, or at least substantially around, the perimeter of the clips 140. Referring again to FIG. 13, each clip 140 can comprise opposing faces, such as a top face 145 and a bottom face 146 on opposite sides of the clip 140 wherein, when the clips 140 are stacked in the housing 132, the top face 145 of a clip 140 can be positioned against the bottom face 146 of an adjacent clip 140 and wherein the bottom face 146 of the clip 140 can be positioned against the top face 145 of another adjacent clip 140. In various circumstances, the bottom faces 146 of the clips 140 can face downwardly toward one or more support shelves, or platforms, 135 defined in the housing 132 while the top faces 145 of the clips 140 can face upwardly away from the support shelves 135. The top faces 145 and the bottom faces 146 of the clips 140 may be identical, or at least substantially identical, in some cases, while, in other cases, the top faces 145 and the bottom faces 146 may be different. The stack of clips 140 depicted in FIGS. 14-16 comprises five clips 140, for example; however, other embodiments are envisioned in which the stack of clips 140 can include more than five clips 140 or less than five clips 140. In any event, the clip cartridge 130 can further comprise at least one biasing member, such as biasing member 136, for example, positioned intermediate the housing 132 and the top clip 140 in the stack of clips 140. As described in greater detail below, the biasing member 136 can be configured to bias the bottom clip 140 in the stack of clips 140 or, more particu-

14

larly, the bottom face 146 of the bottom clip 140, against the support shelves 135 defined in the housing 132. The biasing member 136 can comprise a spring, and/or any suitable compressed elastic element, for example, which can be configured to apply a biasing force to the clips 140, or at least apply a biasing force to the top clip 140 which is transmitted downwardly through the stack of clips 140.

When a clip 140 is positioned against the support shelves 135 as described above, the clip 140 can be supported in a firing position in which the clip 140 can be advanced and ejected from the cartridge 130. In various circumstances, the support shelves 135 can define at least a portion of a firing chamber 149 in which the clips 140 can be sequentially positioned in the firing position. In some cases, the firing chamber 149 can be entirely defined within the cartridge 130 or, in other cases, the firing chamber 149 can be defined within and/or between the shaft 110 and the cartridge 130. In any event, as described in greater detail further below, the clip applicator 100 can comprise a firing drive which can advance a firing member into the cartridge 130 and push the clip 140 from its firing position positioned against the support shelves 135 to a fired position in which it is received within the end effector 120 of the clip applicator 100. Referring primarily to FIGS. 14-16, the housing 132 of the cartridge 130 can comprise a proximal opening, or window, 133 which can be aligned, or at least substantially aligned, with the support shelves 135 such that the firing member can enter into the cartridge 130 through the proximal opening 133 and advance a clip 140 distally out of the cartridge 130. In at least one such embodiment, the housing 132 can further comprise a distal, or discharge, opening, or window, 137 which is also aligned with the support shelves 135 such that the clip 140 can be advanced, or fired, distally along a firing axis 139 extending through the proximal opening 133, the firing chamber 149, and the distal opening 137, for example.

In order to advance a clip 140 out of the cartridge 130, further to the above, the firing member of the firing drive can be advanced into the cartridge housing 132 and, in various circumstances, into the firing chamber 149. As disclosed in greater detail further below, the firing member can pass entirely through the cartridge 130 in order to advance the clip 140 into its fired position within the end effector 120. After the clip 140 positioned in the firing chamber 149 has been advanced distally by the firing member, as outlined above, the firing member can be retracted sufficiently such that the biasing member 136 can position another clip 140 against the support shelves 135. In various circumstances, the biasing member 136 can bias a clip 140 against the firing member while the firing member is positioned within the housing 132. Such a clip 140 can be referred to as a queued clip. After the firing member has been sufficiently retracted and slid out from underneath the queued clip 140, the biasing member 136 can then bias the clip 140 against the support shelves 135 where it is staged for the next stroke of the reciprocating firing member. Referring primarily to FIGS. 2 and 14-16, the cartridge 130 can be configured to supply the clips 140 to the firing chamber 149 along a predetermined path, such as supply axis 138, for example. The supply axis 138 can be transverse to the firing axis 139 such that the clips 140 are fed into the firing chamber 149 in a direction which is different than the direction in which the firing member passes through the firing chamber 149. In at least one such embodiment, the supply axis 138 can be perpendicular, or at least substantially perpendicular, to the firing axis 139, for example.

Referring again to FIG. 2, the shaft 110 can comprise a cartridge, or magazine, aperture 131 which can be sized and

configured to receive a clip cartridge 130, for example, therein. The cartridge aperture 131 can be sized and configured such that the housing 132 of the cartridge 130 is closely received within the cartridge aperture 131. The sidewalls which define the cartridge aperture 131 can limit, or at least substantially limit, the lateral movement of the cartridge 130 relative to the shaft 110. The shaft 110 and/or the cartridge 130 can further comprise one or more locks which can be configured to releasably hold the cartridge 130 in the cartridge aperture 131. As illustrated in FIG. 2, the cartridge 130 can be loaded into the cartridge aperture 131 along an axis which is, in at least one embodiment, parallel to or collinear with the supply axis 138. As also illustrated in FIG. 2, the shaft 110 can further comprise a pad or seat 118 extending from the sidewall 111 of the shaft 110 wherein the pad 118 can be configured to be received within and/or engaged with the housing 132 of the cartridge 130. The pad 118 can be sized and configured to be closely received within a recess 148 defined in the cartridge housing such that the pad 118 can limit, or at least substantially limit, the lateral movement of the cartridge 130 relative to the shaft 110. The pad 118 can be sized and configured to align the cartridge 130 within the shaft 110 and/or support the cartridge housing 132.

Once the clip cartridge 130 has been positioned and seated within the shaft aperture 131, referring now to FIGS. 5 and 6, a firing drive 160 of the clip applicator 100 can be actuated to advance the clips 140 from the clip cartridge 130 as described above. The firing drive 160 can comprise a rotary drive input such as a drive screw 161, for example, and a displaceable firing nut 163 operably engaged with the drive screw 161. The drive screw 161 can comprise at least one drive thread 162 which can be threadably engaged with a threaded aperture extending through the firing nut 163. In various embodiments, the clip applicator 100 can further include an electric motor, for example, operably coupled with the drive screw 161. In various instances, the drive screw 161 can be operably coupled with the motor of a surgical instrument system comprising a hand-held instrument or a robotic arm, for example. In any event, the movement of the firing nut 163 within the shaft 110 can be constrained such that the firing nut 163 moves along a longitudinal axis 164 when the drive screw 161 is rotated about the longitudinal axis 164 by the motor. For instance, when the drive screw 161 is rotated in a first direction by the motor, the drive screw 161 can advance the firing nut 163 distally toward the end effector 120, as illustrated in FIG. 6. When the drive screw 161 is rotated in a direction opposite the first direction by the motor, the drive screw 161 can retract the firing nut 163 proximally away from the end effector 120. The shaft 110 can comprise one or more bearings which can be configured to rotatably support the drive screw 161. For instance, a bearing 159 can be configured to rotatably support the distal end of the drive screw 161, for example, as illustrated in FIGS. 5 and 6.

The firing drive 160 can further comprise a firing member 165 extending from the firing nut 163 which can be advanced distally and retracted proximally with the firing nut 163, as described in greater detail further below. Upon comparing FIGS. 5 and 6, the reader will note that the firing nut 163 and the firing member 165 have been advanced from a proximal, unfired position, illustrated in FIG. 5, to a distal, fired position, illustrated in FIG. 6, in which the firing member 165 has advanced a clip 140 from the clip cartridge 130 into the end effector 120. Referring primarily to FIG. 5, the clip cartridge 130 is illustrated as comprising a plurality of clips 140 stored therein wherein one of the clips 140 is

positioned in a firing position, as described above. As illustrated in FIGS. 5 and 6, the firing member 165 can include a distal portion 166 which can be advanced into the staple cartridge 130 along a firing axis 167 and engage the clip 140 positioned in the firing position when the firing member 165 and the firing nut 163 are advanced distally. In some cases, the firing member 165 can comprise a linear member while, in other cases, the distal end 166 of the firing member 165 can extend upwardly from the firing member 165, for example. Further to the above, the firing member 165 can advance the clip 140 distally out of the clip cartridge 130 along the firing axis 167 and into a receiving cavity 122 defined in the end effector 120.

In various cases, the firing member 165 can be attached to and extend distally from the firing nut 163 while, in other cases, the firing member 165 and the firing nut 163 can be operably connected to one another by a firing actuator 168. The firing actuator 168 can be pivotably mounted to the firing member 165 at a pivot 169 and can include a distal arm 170a and a proximal arm 170b which can be engaged with a longitudinal slot 113 defined in the housing 112 of the shaft 110. In at least one such embodiment, each of the arms 170a, 170b can include a projection, such as projections 171a and 171b, respectively, extending therefrom which can be configured to slide within the longitudinal slot 113. Further to the above, the firing nut 163 can further include a firing pin 172 extending therefrom which can be configured to engage the distal arm 170a in order to advance the actuator 168 and the firing member 165 distally, as described above. In use, referring again to the progression illustrated in FIGS. 5 and 6, the firing nut 163 can be advanced distally by the drive screw 161 wherein the firing pin 172, which is positioned intermediate the distal arm 170a and the proximal arm 170b, can contact the distal arm 170a and drive the actuator 168 and the firing member 165 distally. As the actuator 168 is advanced distally, the actuator 168 may be prevented from rotating about the pivot pin 169 as one or both of the projections 171a and 171b sliding in the shaft slot 113 can be prevented from being moved laterally relative to the longitudinal shaft slot 113 until the actuator 168 reaches the position illustrated in FIG. 6.

When the actuator 168 has reached the position illustrated in FIG. 6, the distal projection 171a can enter into a distal slot portion 114 of the longitudinal slot 113 which can be configured to pivot the actuator 168 downwardly, or permit the actuator 168 to be pivoted downwardly, as illustrated in FIG. 9. In at least one such embodiment, the distal projection 171a can come into contact with the sidewall of the distal slot portion 114 which can guide the distal projection 171a downwardly and pivot the actuator 168 about the pivot 169 as the actuator 168 is advanced forward by the firing nut 163. In such a pivoted position, the firing pin 172 extending from the firing nut 163 may no longer be engaged with the distal arm 170a of the actuator 168 wherein, subsequently, the firing nut 163 may move distally independently of the actuator 168 thereby leaving behind the actuator 168 and the firing member 165. Stated another way, the distal end 114 of the longitudinal shaft slot 113 may deactivate the firing member 165 wherein, at such point, the position of the firing member 165 may represent the fully-fired or distal-most position of the firing member 165. In such a position, the clip 140 has been fully advanced into the receiving cavity, or receiver, 122. Furthermore, in such a position, the next clip 140 to be advanced into the receiving cavity 122 may be biased against the top surface of the firing member 165, further to the above.

Once a clip **140** has been positioned within the receiving cavity **122**, further to the above, the clip **140** can be deformed by a crimping drive **180**, for example. Referring now to FIGS. **3** and **4**, the end effector **120** of the clip applicator **100** can further comprise a first jaw **123a** and a second jaw **123b** wherein the first jaw **123a** and the second jaw **123b** can at least partially define the receiving chamber **122**. As illustrated in FIGS. **3** and **4**, the first jaw **123a** can comprise a first channel **124a** and the second jaw **123b** can comprise a second channel **124b** which can each be configured to receive and support at least a portion of a clip **140** therein. The first jaw **123a** can be pivotably coupled to a frame **111** of the shaft **110** by a pin **125a** and the second jaw **123b** can be pivotably coupled to the frame **111** by a pin **125b**. In use, the crimping drive **180** can be configured to rotate the first jaw **123a** toward the second jaw **123b** and/or rotate the second jaw **123b** toward the first jaw **123a** in order to compress the clip **140** positioned therebetween. In at least one such embodiment, the crimping drive **180** can comprise a cam actuator **181** which can be configured to engage a first cam surface **126a** defined on the first jaw **123a** and a second cam surface **126b** on the second jaw **123b** in order to pivot the first jaw **123a** and the second jaw **123b** toward one another. The cam actuator **181** can comprise a collar which at least partially surrounds the first jaw **123a** and the second jaw **123b**. In at least one such embodiment, the collar can comprise an inner cam surface **182** which can be contoured to contact the cam surfaces **126a**, **126b** of the jaws **123a**, **123b** and drive them inwardly toward one another. In various circumstances, the clip **140** positioned within the receiving chamber **122** defined in the end effector **120** can be positioned relative to tissue before the crimping drive **180** is actuated. In some circumstances, the crimping drive **180** can be at least partially actuated prior to positioning the clip **140** relative to the tissue in order to at least partially compress the clip **140**. In certain instances, the clip **140** and the receiving chamber **122** can be sized and configured such that the clip **140** can be biased or flexed inwardly when the end effector **120** is in its unactuated state, as illustrated in FIG. **3**. In various instances, the crimping first jaw **123a** and the second jaw **123b** can be actuated to elastically crimp and/or permanently crimp the clip **140** positioned therebetween.

Further to the above, the firing nut **163** can be configured to actuate the crimping drive **180**. More particularly, referring now to FIG. **7**, the crimping drive **180** can comprise a crimping actuator **188** operably coupled with the cam actuator **181** wherein the crimping actuator **188** can be selectively engaged by the firing nut **163** as the firing nut **163** is advanced distally as described above. In at least one such embodiment, the firing nut **163** can further comprise a second firing pin, such as firing pin **184**, for example, extending therefrom which can be configured to engage the crimping actuator **188** as the firing nut **163** is advancing the firing actuator **168**. Referring again to FIG. **7**, the crimping actuator **188** is positioned in an unactuated position and, when the firing nut **163** is advanced sufficiently to engage a distal arm **190a** of the crimping actuator **188**, the firing nut **163** can rotate the crimping actuator **188** upwardly into an actuated position as illustrated in FIG. **8**. As also illustrated in FIG. **8**, the distal arm **190a** and a proximal arm **190b** can each comprise a projection, such as projections **191a** and **191b**, respectively, extending therefrom which can be positioned within a second longitudinal slot defined in shaft **110**, such as slot **115**, for example. As the crimping actuator **188** is rotated upwardly from its unactuated position about a pivot **189**, the projections **191a** and **191b** can move from the proximal curved end **116** of the longitudinal slot **115** into a

portion of the longitudinal slot **115** which is substantially linear. Similar to the above, the sidewalls of the longitudinal slot **115** can be configured to confine the movement of the crimping actuator **188** along a longitudinal path and can be configured to limit or prevent the rotation of the crimping actuator **188** once the crimping actuator **188** has been rotated upwardly into an at least partially actuated position, as discussed above. As the reader will understand, the firing pin **172** of the firing drive **160** and the firing pin **184** of the crimping drive **180** both extend from the firing nut **163**. For the sake of expediency and demonstration, the firing pins **172** and **184** are illustrated as extending from the same side of the firing nut **163**; however, it is envisioned that the firing pin **172** can extend from a first lateral side of the firing nut **163** while the firing pin **184** can extend from the other lateral side of the firing nut **163**. In such circumstances, the firing actuator **168** can be positioned alongside the first lateral side of the drive screw **161** and the crimping actuator **188** can be positioned alongside the opposite lateral side of the drive screw **161**. Correspondingly, the longitudinal slot **113** can be defined in a first lateral side of the shaft housing **112** while the longitudinal slot **115** can be defined in the opposite lateral side of the shaft housing **112**.

Further to the above, the cam actuator **181** can be operably coupled with crimping actuator **188** such that, when the crimping actuator **188** is advanced distally by the firing nut **163**, the cam actuator **181** can be advanced distally, as illustrated in FIGS. **8** and **10**, until the distal projection **191a** extending from the distal arm **190a** reaches the distal end **117** of the longitudinal slot **115**. In such a distal position, the cam actuator **181** may be in a fully advanced position and the clip **140** positioned within the receiving chamber **122** can be in a fully deformed or crimped configuration. Thereafter, the cam actuator **181** can be retracted and the end effector **120** can be reopened. More particularly, the drive screw **161** can be rotated in an opposite direction in order to move the firing nut **163** proximally and retract the cam actuator **181** wherein, in certain instances, the end effector **120** can further include a biasing member which can be configured to bias the first jaw **123** and the second jaw **123b** from the closed, or fired, position illustrated in FIG. **4** into the open, or unfired, position illustrated in FIG. **3**. As the firing nut **163** is retracted from its position illustrated in FIG. **10**, the firing pin **184** extending from the firing nut **163** can engage the proximal arm **190b** of the crimping actuator **188** and move the crimping actuator **188**, and the cam actuator **181** extending therefrom, proximally as illustrated in FIG. **12**. Similar to the above, the proximal projection **191b** extending from the proximal arm **190b** of the crimping actuator **188** can be configured to contact the sidewall of the curved proximal end **116** wherein the sidewall can guide the crimping actuator **188** downwardly and rotate the crimping actuator **188** about the pivot **189**. At such point, the firing pin **184** may no longer be engaged with the crimping actuator **188**, the cam actuator **181** may be fully retracted, and the firing nut **163** may continue to be retracted proximally relative to the crimping actuator **188**.

Further to the above, referring now to FIG. **11**, the firing nut **163** can be configured to re-engage the firing actuator **168** as the firing nut **163** is being retracted proximally. As discussed above, the firing actuator **168** is rotated downwardly when the firing actuator **168** reaches the distal end **114** of the longitudinal slot **113** and, as a result, the firing actuator **168** may still be in its downwardly rotated position when the firing nut **163** is retracted proximally to re-engage the firing actuator **168**. As illustrated in FIG. **11**, the firing pin **172** extending from the firing nut **163** can engage the

19

proximal arm **170b** of the firing actuator **168** and, as the firing nut **163** is further retracted, the firing nut **163** can rotate the firing actuator **168** upwardly such that the projections **171a** and **171b** extending from the arms **170a** and **170b**, respectively, can re-enter the longitudinal portion of the longitudinal slot **113**. Thereafter, the firing nut **163** and can be retracted until the firing actuator **168** and the firing member **165** extending therefrom have been returned to their starting, or unfired, positions illustrated in FIG. 5. In such circumstances, the firing member **165** can be withdrawn from the clip cartridge **130** as the firing member **165** is retracted proximally by the firing nut **163** such that a new clip **140** can be biased into the firing chamber of the clip cartridge **130** by the biasing member **136**. Once the firing member **165** and the firing actuator **168** have been retracted to their starting positions and the next clip **140** has been positioned within the firing chamber, the firing drive **160** can be actuated once again in order to move the firing nut **163** and the firing member **165** distally to advance the next clip **140** into the end effector **120**. Likewise, the firing nut **163** can re-actuate the crimping drive **180** as the firing nut **163** is moved distally once again in order to deform the next clip **140**. Thereafter, the firing nut **163** can be retracted in order to re-set the crimping drive **180** and the firing drive **160** once again. This process can be repeated until a sufficient number of clips **140** have been applied to the targeted tissue and/or until the clips **140** contained within the clip cartridge **130** have been depleted. In the event that additional clips **140** are needed, the expended clip cartridge **130** can be removed from the shaft **110** and a replacement clip cartridge **130** containing additional clips **140** can be inserted into the shaft **110**. In some circumstances, an at least partially depleted clip cartridge **130** can be replaced with an identical, or at least nearly identical, replacement clip cartridge **130** while, in other circumstances, the clip cartridge **130** can be replaced with a clip cartridge having more than or less than five clips **140** contained therein and/or a clip cartridge having clips other than clips **140** contained therein, for example.

Referring again to FIGS. 6-9, the firing nut **163** of the illustrated embodiment can be configured to become disengaged from the firing actuator **168** at the same time that the firing nut **163** becomes engaged with the crimping actuator **188**. Stated another way, the firing drive **160** can be deactivated at the same time that the crimping drive **180** is activated. In various circumstances, such timing can be achieved when the distal end **114** of the longitudinal slot **113** is aligned, or at least substantially aligned, with the proximal end **116** of the second longitudinal slot **115**, for example. In the illustrated embodiment and/or any other suitable embodiment, a lag can exist between the deactivation of the firing drive **160** and the activation of the crimping drive **180**. Such a lag between the end of the firing stroke of the firing member **165** and the beginning of the firing stroke of the cam actuator **181** can be created, in some circumstances, to assure that the clip **140** has been positioned in its fully-seated position within the receiving chamber **122** before the clip **140** is deformed by the cam actuator **181**. In various circumstances, such a lag can be created when the distal end **114** of the longitudinal slot **113** is positioned proximally with respect to the proximal end **116** of the second longitudinal slot **115**, for example. In the illustrated embodiment and/or any other suitable embodiment, the deactivation of the firing drive **160** may occur after the activation of the crimping drive **180**. Such an overlap between the end of the firing stroke of the firing member **165** and the beginning of the firing stroke of the cam actuator **181** can be created, in

20

some circumstances, to apply at least some inward pressure on the clip **140** as it is moved into its fully-seated position within the receiving chamber **122** so as to reduce or eliminate relative movement between the clip **140** and the side-walls of the receiving chamber **122**, for example. In various circumstances, such an overlap can be created when the distal end **114** of the longitudinal slot **113** is positioned distally with respect to the proximal end **116** of the second longitudinal slot **115**, for example.

In the illustrated embodiment of FIG. 1 and/or any other suitable embodiment, turning now to FIG. 17, a clip cartridge, such as clip cartridge **230**, for example, can comprise a pusher plate **248** positioned intermediate the biasing member **136** and the top-most clip **140** stacked within the clip cartridge **230**. The pusher plate **248** can be rigid, or at least substantially rigid, and can comprise a first bearing surface against which the biasing member **136** can apply a biasing force. The pusher plate **248** can also comprise a second bearing surface which can transmit the biasing force to the top surface **145** of the top-most clip **140**. The pusher plate **248** can be comprised of a sheet of stainless steel material, for example, although the pusher plate **248** can comprise any suitable shape and can be comprised of any suitable material. In certain instances, the pusher plate **248** may not be attached to the biasing member **136** while, in other instances, the pusher plate **248** can be affixed to the biasing member **136** such that the pusher plate **248** does not become dislodged from the cartridge housing **132**. In various circumstances, the pusher plate **248** can be sized and configured such that it cannot pass through the proximal opening **133** and/or the distal opening **137** defined in the cartridge housing **132**.

In the illustrated embodiment of FIG. 1 and/or any other suitable embodiment, turning now to FIGS. 18 and 19, a clip cartridge, such as clip cartridge **330**, for example, can comprise a lockout member which can be positioned within the firing chamber **149** of the clip cartridge **330** after all of the clips **140** contained within the clip cartridge **330** have been ejected from the cartridge **330**. The lockout member can comprise a lockout plate **348** which can be positioned intermediate the biasing member **136** and the top surface **145** of the top-most clip **140** contained within the clip cartridge **330**. In use, further to the above, the clips **140** can be sequentially positioned in the firing chamber **149** of the clip cartridge **130** and then advanced distally out of the clip housing **132** wherein, after the last clip **140** has been advanced out of the clip housing **132** and the firing member **165** has been withdrawn from the clip cartridge **130**, the biasing member **136** can bias the lockout plate **348** against the shelves **135**. In such a position, the lockout plate **348** can be aligned with the proximal opening **133** and the distal opening **137** such that the firing member **165** cannot enter, or at least substantially enter, the clip cartridge **130**. In such circumstances, the lockout plate **348** can block the firing member **165** from entering into and passing through the housing **132** and, as a result, prevent the inadvertent firing of the clip applicator **100** after the clip cartridge **130** has run out of clips. In the event that the operator of the clip applicator **100** were to actuate the firing drive **160** and attempt to advance the firing member **165** into the spent clip cartridge **130**, the firing member **165** would contact and abut the lockout plate **348** wherein, in such circumstances, a compressive load can be created within the firing member **165**. The clip applicator **100** can further include a clutch which can be configured to slip and operably disconnect the motor from the drive screw **161** when the compressive load created within the firing member **165** exceeds a certain or predetermined amount. In

addition to or in lieu of a clutch, the motor and/or motor controller of the clip applier 100 which operates the firing drive 160, for example, can comprise a load sensor configured to detect the load generated within the firing member 165 and, when the load created within the firing member 165 exceeds a certain or predetermined amount, the voltage and/or current supplied to the motor can be switched off and/or reduced. In any event, the lockout plate 348 can be sized and configured such that the lockout plate 348 cannot be dislodged through the distal opening 137 and/or the proximal opening 133 when the firing member 165 contacts the lockout plate 348. In order to use the clip applier 100 once again, the operator of the clip applier 100 can remove the spent cartridge 330 from the shaft 110 and insert a new clip cartridge 330, for example, into the shaft 110. At such point, a clip 140 may be positioned within the firing chamber 149 of the new clip cartridge 330 and the firing member 165 can be advanced distally into the new clip cartridge 330 to deploy the clip 140 as described above.

In the illustrated embodiment of FIG. 1 and/or any other suitable embodiment, referring now to FIGS. 20 and 21, a clip cartridge, such as clip cartridge 430, for example, can comprise guides which can be configured to limit or confine the movement of a lockout member within the clip cartridge 430. Similar to the above, the lockout member can comprise a lockout plate 448, for example, which can be positioned intermediate the biasing member 136 and the top surface 145 of the top-most clip 140 contained within the housing 432 of the clip cartridge 430. In use, similar to the above, the lockout plate 448 can be progressively pushed downwardly into the firing chamber 149 as the clips 140 are sequentially ejected from the clip cartridge 430. The lockout plate 448 can be sized and configured such that it is closely received within the cartridge housing 432 and such that relative lateral movement between the lockout plate 448 and the housing 432 can be limited in order to reduce, or prevent, the possibility of the lockout plate 448 becoming misaligned within the clip cartridge 430. In the event that the lockout plate 448 were to become misaligned within the clip cartridge 430, the lockout plate 448 may bind within the housing 432 and prevent the biasing member 136 from applying an appropriate biasing force to the stack of clips 140, for example. As illustrated in FIGS. 20 and 21, the lockout plate 438 can further comprise guide members 447 extending therefrom which can be received within guide slots 446 defined in the cartridge housing 432. The guide members 447 and the guide slots 446 can be sized and configured such that the guide members 447 are closely received within the guide slots 446 and such that relative lateral movement between the lockout plate 438 and the cartridge housing 432 can be limited. Each of the guide slots 446 can be defined by opposing sidewalls 445 which can define a distance therebetween which is equal to or slightly larger than the width of the guide member 447 positioned therein such that the guide member 447 can slide between the opposing sidewalls 445 between the top 443 and the bottom 444 of the guide slot 446. Thus, while the guide members 447 and the guide slots 446 can be configured to limit lateral movement therebetween, as outlined above, the guide members 447 and the guide slots 446 can be configured to permit relative movement between the lockout plate 438 and the cartridge housing 432 along a predetermined path parallel to or collinear with the supply axis 138, for example. When the lockout plate 438 is pushed into the firing chamber 149 by the biasing member 136, the lockout plate 438 can inhibit the advancement of the firing member 165 and the operation of the clip applier 100, as outlined

above, until the spent clip cartridge 430 is replaced with another suitable clip cartridge.

In the illustrated embodiment of FIG. 1 and/or any other suitable embodiment, as discussed above, the drive screw 161 can be rotated in a first direction to advance the firing nut 163 distally and rotated in a second, or reverse, direction to retract the firing nut 163 proximally. In order to rotate the drive screw 161 in the first and second directions, the electric motor operably coupled with the drive screw 161 can be operated in corresponding first and second directions. In the illustrated embodiment of FIG. 1 and/or any other suitable embodiment, a clip applier can utilize a motor which is operated in only a first direction wherein the rotation of the motor in such a single direction can be utilized to advance a firing nut distally and retract the firing nut proximally. Turning now to FIGS. 22-26, the output of an electric motor can be transmitted to a drive system 560 via a transmission system 550. The transmission system 550 can comprise an input shaft 552 which is operated in a single direction wherein the transmission system 550 can be switchable or shiftable between a first state, or configuration, in which the transmission system 550 rotates a drive screw 561 of the drive system 560 in a first direction and a second state, of configuration, in which the transmission system 550 rotates the drive screw 561 in a second, or opposite, direction. The first state of the transmission system 550 is depicted in FIGS. 22-24 and the second state of the transmission system 550 is depicted in FIGS. 25 and 26.

Referring again to FIGS. 22-24, the input shaft 552 can comprise an input gear 551 mounted thereto which is operably coupled, or meshingly engaged, with a shifter gear 553 such that the rotation of the input shaft 552 is transmitted to the shifter gear 553. With regard to all of the gears discussed herein, gears which are operably coupled or meshingly engaged with one another can comprise any suitable arrangement of teeth, for example, which can transmit the rotation of one gear to the other. When the input shaft 552 is rotated in the first direction, the shifter gear 553 is rotated in the second, or opposite, direction. In the first state of the transmission system, the shifter gear 553 is in a first position in which the shifter gear 553 is operably coupled with an intermediate gear 554 wherein, when the shifter gear 553 is rotated in the second direction by the input gear 551, as discussed above, the intermediate gear 554 is rotated in the first direction. Although not illustrated, the intermediate gear 554 can be rotatably supported within the shaft 110 of the clip applier 100, for example. The intermediate gear 554 can also be operably coupled with an output gear 555 mounted to the drive screw 561 such that the rotation of the intermediate gear 554 can be transmitted to the output gear 555. When the intermediate gear 554 is driven in the first direction by the shifter gear 553, as described above, the intermediate gear 554 can drive the output gear 555 and the drive screw 561 in the second direction. Similar to the above, the firing nut 563 can be operably coupled with the drive screw 561 and suitably constrained within the shaft 110 such that, when the drive screw 561 is rotated in the second direction, the firing nut 563 is advanced distally as indicated by the arrow D.

Similar to the above, the firing nut 563 can be advanced to its distal-most position, illustrated in FIG. 24, in order to advance a clip 140 from the clip cartridge 130 into the end effector 120 and crimp the clip 140 as described above. As illustrated in FIGS. 23 and 24, the firing nut 563 can further comprise a cam bar 569 extending therefrom which can be configured to shift the transmission system 550 from its first state to its second state. Upon comparing FIG. 24 and FIG.

25, the reader will note that the shifter gear 553 is movable between a first position in which the transmission system 550 is in its first state and a second position in which the transmission system 550 is in its second state. More particularly, the shifter gear 553 is mounted to a shifter 556 which is rotatable about the input shaft 552 such that the shifter gear 553 can be rotated from its first position in which the shifter gear 553 is operably engaged with the input gear 551 and the intermediate gear 554 and its second position in which the shifter gear 553 is operably disengaged from the intermediate gear 554. Although the shifter gear 553 is operably disengaged from the intermediate gear 554 when the shifter gear 553 is in its second position, the shifter gear 553 can be operably coupled with the input gear 551 and the output gear 555 in order to transmit rotary motion from the input shaft 552 to the drive screw 561. As illustrated in FIGS. 24 and 25, the shifter 556 can comprise a central aperture through which the input shaft 552 can extend; however, the shifter 556 may not be operably engaged with the input shaft 552 and, as a result, the rotation of the input shaft 552 may not rotate the shifter 556 and, likewise, the rotation of the shifter 556 may not rotate the input shaft 552. In any event, the shifter 556 can further comprise a cam follower 558 extending therefrom which can be engaged by a cam 568 defined on the cam bar 569 as the firing nut 563 is advanced distally. When the cam 568 engages the cam follower 558, the cam 568 can rotate the shifter 556 and the shifter gear 553 between its first position and its second position as described above.

When the shifter gear 553 is in its second position and the transmission system 550 is in its second state, as described above, the input shaft 552 and the drive screw 561 can both be rotated in the first direction. More particularly, the input shaft 552, when rotated in the first direction, can rotate the input gear 551 in the first direction and, as the shifter gear 553 is directly engaged with the input gear 551, the shifter gear 553 will be rotated in the second direction. The reader will note that the shifter gear 553 rotates in the second direction when the transmission system 550 is in its second state as compared to the first, or opposite, direction when the transmission system 550 is in its first state. Upon comparing FIGS. 24 and 25, further to the above, the reader will appreciate that the intermediate gear 554 is no longer operably positioned intermediate the input gear 551 and the shifter gear 553 when the transmission system 550 is in its second state thereby accounting for the different directions of rotation. As the shifter gear 553 is operably engaged with the input gear 551 and the output gear 555 when the shifter gear 553 is in its second position, the shifter gear 553 can rotate the output gear 555, and the drive screw 561 coupled to the output gear 555, in the first direction. When the drive screw 561 is rotated in the first direction, as illustrated in FIGS. 25 and 26, the firing nut 563 can be retracted proximally to permit the end effector 120 to be reopened and to retract the firing member 165. Referring primarily to FIG. 26, the firing nut 563 can further comprise a second cam bar 567 extending therefrom comprising a cam 566 which can be configured to contact the cam follower 558 of the shifter 556 as the firing nut 563 is retracted proximally into its fully-retracted position. In such circumstances, the cam 566 can push the shifter 556 back into its first position and into operative engagement with the intermediate gear 554 such that the transmission system 550 can be reset into its first state and the clip applier 100 can be actuated once again.

As discussed above, the firing drive of the clip applier 100 can be operated by a surgical instrument system comprising an electric motor. A robotic surgical instrument system 20 is

illustrated in FIG. 27 and can comprise a plurality of movable arms 30. Each arm 30 can comprise an actuator module 32 comprising an electric motor configured to supply the rotary motion to the shaft 110 of a clip applier 100, and/or any other suitable surgical instrument. Referring now to FIG. 28, an end effector 620 may be selectively engageable with and disengageable from an actuator shaft 610 of a clip applier wherein the end effector 620 can comprise a proximal end 621 which can be coupled to a distal end 611 of the shaft 610. The proximal end 621 of the end effector 620 can comprise an outer housing 629, a frame extending through the outer housing 629, an outer drive shaft extending through the frame, and an inner drive shaft extending through the outer drive shaft. Similarly, the distal end 611 of the shaft 610 can comprise an outer housing 619, a frame 663 extending through the outer housing 619, an outer drive shaft 662 extending through the frame 663, and an inner drive shaft 661 extending through the outer drive shaft 662. With regard to the distal end 611 of the shaft 610, the frame 663, the outer drive shaft 662, and the inner drive shaft 661 can each comprise a portion of a tongue connector 613 extending therefrom and a portion of a connector groove 612 defined therein, wherein the tongue connector 613 can be configured to be received within a tongue groove 623 defined in the proximal end 621 of the end effector 620, and wherein the tongue groove 612 can be configured to receive a tongue connector 622 extending from the proximal end 621 of the end effector 620. Similar to the tongue connector 613 which extends across the frame 663, the outer drive shaft 662, and the inner drive shaft 661 of the distal shaft end 611, the tongue connector 622 can extend across the frame, the outer drive shaft, and the inner drive shaft of the proximal end 621 of the end effector 620. Also, similar to the tongue groove 612 which extends across the frame 663, the outer drive shaft 662, and the inner drive shaft 661 of the distal shaft end 611, the tongue groove 623 can extend across the frame, the outer drive shaft, and the inner drive shaft of the proximal end 621 of the end effector 620. In the configuration depicted in FIG. 28, the tongue connector 622 of the end effector 620 can be slid laterally into the tongue groove 612 of the shaft 610 at the same time that the tongue connector 613 of the shaft 610 is slid laterally into the tongue groove 623 of the end effector 620. Owing to such assembly, the frame of the end effector 620 can be securely coupled to the frame 663 of the shaft 610, the outer drive shaft of the end effector 620 can be operably coupled to the outer drive shaft 662 of the shaft 110, and the inner drive shaft of the end effector 620 can be operable coupled to the inner drive shaft 661 of the shaft 110. The reader will note that the portions of the tongue connector 612 are aligned with one another, the portions of the tongue groove 613 are aligned with one another, the portions of the tongue groove 622 are aligned with one another, and the portions of the tongue connector 623 are aligned with one another when the end effector 620 is assembled to the shaft 610. Once assembled, the outer drive shaft 662 of the shaft 110 can rotate the outer drive shaft of the end effector 620, and the inner drive shaft 661 of the shaft 610 can rotate the inner drive shaft of the end effector 620. When the outer drive shaft 662 and/or the inner drive shaft 661 are rotated, the portions of the tongue connector 612, the portions of the tongue groove 613, the portions of the tongue groove 622, and the portions of the tongue connector 623 may no longer be aligned. In order to remove the end effector 620 from the shaft 610, the inner drive shaft 661 and/or the outer drive shaft 662 can be rotated into one or more positions in which

the tongue connectors **612** and **623** and the tongue grooves **613** and **622** are sufficiently aligned.

Referring again to FIG. 28, the outer housing **619** of the shaft **610** can further comprise a stop **614** which can be configured to limit the lateral movement of the end effector **620** as the end effector **620** is being slid transversely onto the distal end **611** of the shaft **610**. The stop **614** can provide a datum from which the inner drive shaft of the end effector **620** and the inner drive shaft **661** of the shaft **610** are aligned along longitudinal axis **615**, the outer drive shaft of the end effector **620** and the other drive shaft **662** of the shaft **610** are aligned along longitudinal axis **615**, and/or the frame of the end effector **620** and the frame **663** of the shaft **610** are aligned along the longitudinal axis **615**. Further to the above, the inner drive shaft **661** can extend into an actuator module **632** which can comprise an electric motor and/or gear train **664** operably coupled with the inner drive shaft **661** configured to rotate the inner drive shaft **661**. Furthermore, the actuator module **632** can comprise a second electric motor and gear train operably engaged with the second drive shaft **662** configured to drive the second drive shaft **662**. As described in greater detail below, a second electric motor can be utilized to articulate the end effector **620**. Also, further to the above, the outer housing **619** and/or the frame **663** of the shaft **610** can further comprise a gear **617** mounted thereto which is operably engaged with an electric motor and gear train **618** which can be configured to rotate the shaft **610** and the end effector **620** about the longitudinal axis **615**. For instance, if the electric motor and gear train **618** are operated in a first direction, the shaft **610** and the end effector **620** can be rotated about the axis **615** in a clockwise direction while, if the electric motor and gear train **618** are operated in a second direction, the shaft **610** and the end effector **620** can be rotated about the axis **615** in a counter-clockwise direction in order to position and orient the end effector **620**.

As discussed above, the end effector **620** can be selectively attached to and detached from the shaft **610**. The reader will note that the principles discussed in connection with the end effector **620** and shaft **610** can be equally applied to the end effector **120** and the shaft **110** of the embodiment disclosed in FIG. 1, among others. That said, referring again to FIG. 27, one of the robotic arms **30** can be selectively engaged with an end effector **120** of a clip applicator, or, alternatively, any other suitable end effector, such as the end effector of a surgical stapler, for example. In such circumstances, an end effector **120** can be selectively interchanged with another end effector and, as a result, a single robotic arm **30** can be utilized to perform more than one function. Stated another way, the clip applicator **100** can comprise a replaceable loading unit which can be replaced by, or interchanged with, another clip applicator loading unit and/or any other suitable replaceable loading unit. Turning now to FIG. 29, the end effector **120** and the shaft **110** of the clip applicator **100** can be utilized with a surgical instrument system comprising a handle **700**. The handle **700** can comprise an actuator **701** which can be operated, or squeezed toward grip **702**, in order to apply a rotary motion to the drive screw **161** as described above. In some cases, the rotation of the actuator **701** can be mechanically transmitted to the drive screw **161** while, in other cases, the actuator **701** can operate a motor operably coupled to the drive screw **161**.

Further to the above, the end effector **120** and the shaft **110** of the clip applicator **100** can be aligned along a longitudinal axis of the clip applicator **100**. Turning now to FIG. 30, the end effector **120** and/or the shaft **110** can further comprise an articulation joint **101** which can be configured to permit the end effector **120** to be articulated relative to the

longitudinal axis of the clip applicator **100**. The shaft **110** can comprise an outer housing, or frame portion, **119** which can comprise a proximal end **102** and can comprise a distal portion of the articulation joint **101**. The proximal end **102** can comprise a spherical, or an at least substantially spherical, end **102**, for example, which can be received within a spherical, or an at least substantially spherical, cavity **104** defined in an articulation joint member **103**. The articulation joint member **103** can also comprise a spherical, or at least substantially spherical, end **105**, for example, which can be received within a spherical, or an at least substantially spherical, cavity **107** defined in a shaft frame portion **106**. The proximal end **102** of the shaft **110** can be at least partially captured within the cavity **104** such that the proximal end **102** cannot be readily removed from the cavity **104**. That said, the proximal end **102** and the cavity **104** can be sized and configured to permit the proximal end **102** to be rotated in any suitable direction within the cavity **104**. As also illustrated in FIG. 30, the clip applicator **100** can further comprise articulation controls **108a** and **108b**, for example, which can extend through the articulation joint **101** and can comprise distal ends mounted within mounting apertures **109a** and **109b**, respectively, defined within the proximal end **102** of the shaft housing **119**. In use, the articulation controls **108a** and **108b** can be pushed and/or pulled in order to move the proximal end **102** within the cavity **104**. Further to the above, the end **105** of the articulation joint member **103** can be at least partially captured within the cavity **107** defined in the shaft frame portion **106** such that the end **105** cannot be readily removed from the cavity **107**. That said, the end **105** and the cavity **107** can be sized and configured to permit the end **105** to be rotated in any suitable direction within the cavity **107** when the shaft end **102** is pushed and/or pulled by the actuators **108a** and **108b** as described above.

Further to the above, referring again to FIG. 30, the drive screw **161** can be rotated by an input shaft, such as input shaft **152**, for example. The input shaft **152** can extend through an aperture **156** defined within the shaft frame portion **106**, the articulation joint member **103**, and the proximal end **102** of the shaft housing **119**. The input shaft **152** can comprise an input gear **151** mounted to the distal end thereof which can be operably coupled with an output gear **155** mounted to the proximal end of the drive screw **161**. In use, the input shaft **152** can be rotated by the electric motor, described above, wherein the input shaft **152** can rotate the drive screw **161**. As outlined above, the articulation joint **101** can be configured to permit the end effector **120** and at least a portion of the shaft **110** to be articulated relative to a longitudinal axis defined by the clip applicator **100**. In order to accommodate such movement, at least the portion of the input shaft **152** extending through the articulation joint **101** can be sufficiently flexible.

Turning now to FIGS. 31-34, the articulation actuators **108a** and **108b** can be operated by an actuator module such as module **832**, for example. Referring primarily to FIG. 31, the actuator module **832** can comprise a rotatable articulation driver **833** which can be configured to push and pull the articulation actuators **108a** and **108b**. The articulation driver **833** can comprise a cylindrical, or an at least substantially cylindrical, collar **835** including an aperture **837** which can be configured to receive at least a portion of the shaft frame **106** therein in order to rotatably support the collar **835**. The articulation driver **833** can further comprise an input gear portion **834** which can be operably coupled with an electric motor and gear train **831** of the module **832** wherein, when the electric motor and gear train **831** are actuated, the

articulation driver **833** can be rotated about the shaft frame **106**. Referring primarily to FIGS. **32** and **34**, the articulation driver **833** can further comprise two cam slots defined in the sidewall of the collar aperture **837**, although the reader will note that only one cam slot **835a** is illustrated in the provided views. The cam slot **835a** is configured to receive a cam follower **838a** extending from the articulation driver **108a** wherein the cam follower **838a** is configured to slide within the cam slot **835a**. When the articulation driver **833** is rotated, the helical contour of the cam slot **835a**, for example, can be configured to push the cam follower **838a** distally or pull the cam follower **838a** proximally, depending on the direction in which the articulation driver **833** is rotated. As a result of the proximal or distal movement of the cam follower **838a**, the cam actuator **108a** can be moved proximally or distally, respectively. While not illustrated, the articulation driver **108b** can comprise a cam follower, similar to the cam follower **838a**, which can be configured to slide within the other cam slot discussed above. The other cam slot can be configured such that, when the articulation actuator **108a** is driven distally by the articulation driver **833** when the articulation driver **833** is rotated in a first direction, the articulation actuator **108b** can be pulled proximally. Similarly, the other cam slot can be configured such that, when the articulation actuator **108a** is pulled proximally by the articulation driver **833** when the articulation driver **833** is rotated in a second direction, the articulation actuator **108b** can be driven distally. Referring primarily to FIG. **32**, the shaft frame portion **106** can comprise clearance slots **839** defined therein through which the cam followers can extend. Although the above features have been discussed in connection with an actuator module **832**, such features could be used in connection with the other actuator modules disclosed herein.

FIGS. **35A**, **35B**, and **35C** depict a clip applier **70100** in accordance with at least one embodiment. The clip applier **70100** is similar to the clip applier **100** in many respects, most of which will not be repeated herein for the sake of brevity. Similar to the clip applier **100**, the clip applier **70100** comprises an end effector **70120**, a shaft, a clip cartridge, and a firing member **70165**. The clip cartridge comprises a plurality of clips **70140** removably stored therein. The end effector **70120** comprise a first jaw **70123a** and a second jaw **70123b** wherein the first jaw **70123a** and the second jaw **70123b** at least partially define a receiving chamber **70122**. Further, the first jaw **70123a** and the second jaw **70123b** are pivotally coupled to the shaft by a pin **70125** such that the first jaw **70123a** and the second jaw **70123b** are movable relative to each other between an open position (FIG. **35B**) and a closed position (FIG. **35A**). The first jaw **70123a** and the second jaw **70123b** are movable between the open position and the closed position by a crimping drive **70180** (see FIGS. **36-38**). Other embodiments are envisioned where the first jaw **70123a** and the second jaw **70123b** are pivotally coupled to the shaft utilizing at least one pin similar to the first jaw **125a** and second jaw **125b** depicted in FIG. **1**. The first jaw **70123a** and the second jaw **70123b** include pre-form features, such as protrusions **70126a** and **70126b** which are discussed in further detail below.

In use, the firing member **70165** advances a clip **70140** from the clip cartridge onto the protrusions **70126a** and **70126b** as depicted in FIG. **35A**. In this position, the clip **70140** is in a pre-formed configuration. The width of the clip **70140** in the pre-formed configuration can be 0.080" preferably. When the first jaw **70123a** and the second jaw **70123b** are moved from the closed position to the open position, the protrusions **70126a** and **70126b** expand the clip **70140** to an expanded configuration as depicted in FIG. **35B**.

The width of the clip **70140** in the expanded configuration can be 0.210" preferably. During the transition of the clip **70140** from the pre-formed configuration to the expanded configuration, the firing member **70165** supports the backside of the clip **70140**. More specifically, the firing member **70165** includes angled surfaces **70165a** and **70165b** which provide support for the backside of the clip **70140** as the clip **70140** expands. Further, as the clip **70140** is expanded, the firing member **70165** can be advanced to allow the angled surfaces **70165a** and **70165b** to continue to maintain contact against the backside of the clip **70140** as the clip **70140** expands. Once in the expanded configuration, the clip **70140** is advanced into the receiving chamber **70122** by the firing member **70165**. The protrusions **70126a** and **70126b** include angled portions which allow the clip **70140** to slide over the protrusions **70126a** and **70126b** when the clip **70140** is advanced by the firing member **70165**. After the clip **70140** has been advanced into the receiving chamber **70122**, the firing member **70165** is retracted, and the crimping drive **70180** is actuated to transition the first jaw **70123a** and the second jaw **70123b** to the closed position depicted in FIG. **35A** to crimp the clip **70140** positioned in the receiving chamber **70122**. After the clip **70140** is crimped, another clip **70140** can be advanced onto the protrusions **70126a** and **70126b** by the firing member **70165**. When the first jaw **70123a** and the second jaw **70123b** are moved from the closed position to the open position by the crimping drive **70180**, the clip **70140** that has been crimped in the receiving chamber **70122** will be released from the receiving chamber **70122** and the clip **70140** that was advanced onto the protrusions **70126a** and **70126b** will be expanded into to the expanded configuration by the protrusions **70126a** and **70126b** of the first and second jaws **70123a** and **70123b**. Interaction between the crimping drive **70180** and the first and second jaws **70123a** and **70123b** is discussed in further detail below.

FIGS. **36-38** depict the clip applier **70100** as described above. In addition, FIGS. **36-38** further depict the interaction between the crimping drive **70180** and the first and second jaws **70123a** and **70123b**. The crimping drive **70180** comprises a first crimping drive pin **70180a** and a second crimping drive pin **70180b** protruding therefrom. The first jaw **70123a** comprises a first jaw cam **70124a** extending therefrom and the second jaw **70123b** comprises a second jaw cam **70124b** extending therefrom. In use, the crimping drive **70180** is movable between a fully retracted position (FIG. **38**), a home position (FIG. **37**), and a fully-fired position (FIG. **36**). The fully-fired position can preferably be 0.300" distal to the home position. The fully retracted position can preferably be 0.050" proximal to the home position. Other embodiments are envisioned with different distances between the home position, the fully retracted position, and the fully-fired position. The crimping drive **70180** cammingly engages outer surfaces of the first jaw **70123a** and the second jaw **70123b** to transition the first jaw **70123a** and the second jaw **70123b** to a closed position when the crimping drive **70180** is moved into the fully-fired position (FIG. **36**)—similar to the interaction between the crimping drive **180** and the first and second jaws **123a** and **123b** described above. In the home position (FIG. **37**), the first and second crimping drive pins **70180a** and **70180b** engage the first jaw cam **70124a** and the second jaw cam **70124b**, respectively, such that the first jaw **70123a** and the second jaw **70123b** are moved toward the open position to release a crimped clip **70140** from the first and second jaws **70123a** and **70123b**. When the crimping drive **70180** is in

the home position, another clip **70140** can be advanced onto the protrusions **70126a** and **70126b** as discussed above. Further, as the crimping drive **70180** is moved from the home position (FIG. 37) to the fully retracted position (FIG. 38) the first crimping drive pin **70180a** and the second crimping drive pin **70180b** transition the first jaw **70123a** and the second jaw **70123b** towards the open position, and thus, the clip **70140** positioned around the protrusions **70126a** and **70126b** is expanded into the expanded configuration, as discussed above. Alternative embodiments are envisioned in which a crimped clip **70140** is released from the first and second jaws **70123a** and **70123b** and, at the same time, another clip **70140** positioned on the protrusions **70126a** and **70126b** is least partially expanded when the crimping drive is moved from the closed position to the home position.

FIGS. 39 and 40 depict a clip applicator **70150** in accordance with at least one embodiment. The clip applicator **70150** comprises a frame **70155**, a firing member **70160**, a first jaw **70170a**, and a second jaw **70170b**. The first jaw **70170a** and the second jaw **70170b** are pivotally coupled to the frame **70155** such that the first jaw **70170a** and the second jaw **70170b** are movable relative to each other. The clip applicator **70150** is configured to receive various types of clip cartridges, such as clip cartridge **70130** depicted in FIG. 39, for example. The clip cartridge **70130** comprises a cartridge body **70132** including a first cartridge jaw **70132a** and a second cartridge jaw **70132b** that oppose each other. When the clip cartridge **70130** is attached to the frame **70155** of the clip applicator **70150**, the first cartridge jaw **70132a** biases the first jaw **70170a** towards the second jaw **70170b**, and the second cartridge jaw **70132b** biases the second jaw **70170b** towards the first jaw **70170a**. Thus, when the clip cartridge **70130** is attached to the clip applicator **70150**, the first and second jaws **70170a** and **70170b** are approximated to form a receiving chamber **70175**. The clip cartridge **70130** further comprises a plurality of clips **70136** removably stored in a clip housing **70134**. The clip cartridge **70130** further includes biasing members, such as springs **70138** for example, configured to bias the clips **70136** out of the clip housing **70134** into the receiving chamber **70175**. Once in the receiving chamber **70175**, a clip **70136** can be advanced by the firing member **70160** into a crimping chamber in the distal end of the first and second jaws **70170a** and **70170b**. A clip **70136** positioned in the crimping chamber can then be crimped when the first jaw **70170a** and the second jaw **70170b** are moved towards each other.

FIG. 40 depicts a different clip cartridge **70130'** positioned in the clip applicator **70150**. The clip cartridge **70130'** is similar to clip cartridge **70130** discussed above, except for the differences discussed below. The clip cartridge **70130'** is configured to store clips **70136'** which are smaller than clips **70136**. Other embodiments are envisioned where the clip cartridge **70130'** is configured to store clips that are larger than clips **70136**. In any event, clip cartridge **70136'** comprises, one, a clip housing **70134'** which stores the clips **70136'** and, two, biasing members, such as springs **70138'** for example, which bias the stored clips **70136'** into a receiving chamber **70175'**. Further, the clip cartridge **70130'** comprises a cartridge body **70132'**, a first cartridge jaw **70132a'**, and a second cartridge jaw **70132b'** opposing the first cartridge jaw **70132a'**. The first cartridge jaw **70132a'** and the second cartridge jaw **70132b'** extend further inward toward each other as compared to the first cartridge jaw **70132a** and the second cartridge jaw **70132b** of the clip cartridge **70130**. Stated another way, the gap between the first cartridge jaw **70132a'** and the second cartridge jaw

70132b' is smaller than the gap between the first cartridge jaw **70132a** and the second cartridge jaw **70132b**. When the clip cartridge **70130'** is attached to the clip applicator **70150**, the receiving chamber **70175'** defined between the first jaw **70170a** and the second jaw **70170b** will be smaller than the receiving chamber **70175**. By changing the distance between the first cartridge jaw and the second cartridge jaw of the clip cartridges **70130** and **70130'**, various sizes of receiving chambers can be created. The clip cartridges **70130** and **70130'** can therefore be modified to approximate the first jaw **70170a** and the second jaw **70170b** of the clip applicator **70150** to receive any suitable clip size.

FIG. 41 depicts a clip applicator **70200** in accordance with at least one embodiment. The clip applicator comprises a shaft **70210** extending from a housing, an end effector **70220** extending from the shaft **70210**, a feeder member **70230** configured to move through the clip applicator **70200** in response to rotary motions generated in the housing, and a clip magazine **70240**. The end effector comprises a pair of jaws **70225** configured to move relative to each other between open and closed positions. The clip magazine **70240** is not removable from the clip applicator **70200**; however, other embodiments are envisioned where the clip magazine **70240** is removable and/or replaceable. The clip magazine **70240** comprises a first layer **70246** of clips **70244** and a second layer **70248** of clips **70244** stored within the clip magazine **70240**. The first layer **70246** of clips **70244** are in a feeding position from which they can be ejected from the clip magazine **70240**. The second layer **70248** of clips **70244** are stored above the first layer **70246** of clips **70244** in a storage position from which they cannot be ejected from the clip magazine **70240**. Each of the first layer **70246** and second layer **70248** comprises three clips **70244**, however, other embodiments are envisioned with more or less than three clips. The first and second layers **70246** and **70248** are separated by a divider member, such as a divider plate **70249**. The clip magazine **70240** further comprises a top plate **70243** and biasing members **70242**. The top plate **70243** rests on top of the second layer **70248** of clips **70244**. The biasing members **70242** bias the top plate **70243** toward the top of the second layer **70248** of clips **70244** and, thus, bias the second layer **70248** of clips **70244** toward the divider plate **70249**. The divider plate **70249** rests on top of the first layer **70246** of clips **70244** and a distal protrusion **70232** of the feeder member **70230**. The distal protrusion **70232** extends above the feeder member **70230**. Operation of the clip applicator **70200** is discussed in further detail below.

In use, the feeder member **70230** is translated distally to push the first layer **70246** of clips **70244** toward the end effector **70220** and out of the clip magazine **70240**. As the first layer **70246** of clips **70244** is being advanced from the clip magazine **70240**, the divider plate **70249** is supported by the distal protrusion **70232** of the feeder member **70230** and any of the clips **70244** which haven't been fully ejected from the clip magazine **70240**. Once the feeder member **70230** has advanced all of the clips **70244** in the first layer **70246** out of the clip magazine **70240**, the divider plate **70249** is biased by the biasing members **70242** into a recess **70233** in the feeder member **70230**. The recess **70233** is defined between the distal protrusion **70232** of the feeder member **70230** and a proximal protrusion **70234** of the feeder member **70230** extending upward from the proximal end of the feeder member **70230**. Once the divider plate **70249** is seated in the recess **70233**, the feeder member **70230** and divider plate **70249** can be retracted together proximally out of the clip magazine **70240**. After the feeder member **70230** and divider plate **70249** are completely retracted out of the clip

magazine 70240, the second layer 70248 of clips 70244 is biased by the biasing members 70242 into the feeding position (i.e., where the first layer 70246 of clips 70244 used to be). The feeder member 70230 and divider plate 70249 can be advanced together toward the end effector to eject the second layer 70248 of clips 70244 from the clip magazine 70240. The reader will appreciate that all of the clips 70244 in the first layer 70246 and/or second layer 70248 are not ejected at the same time, rather, they are ejected one at a time to allow each clip 70244 to be sequentially crimped by the pair of jaws 70255 of the end effector 70220. The above being said, other embodiments are envisioned in which more than one clip 70244 can be ejected at a time.

FIG. 42A depicts a clip applier 70250 in accordance with at least one embodiment. The clip applier 70250 comprises an elongate shaft 70260 extending from a housing, a clip cartridge 70270 extending from the elongate shaft 70260, and an end effector 70280 extending from the clip cartridge 70270. The elongate shaft 70260 and the clip cartridge 70270 define a shaft axis SA. The elongate shaft 70260 comprises a first inwardly extending detent 70264a and a second inwardly extending detent 70264b opposing the first inwardly extending detent 70264a. The first and second inwardly extending detents 70264a and 70264b extend inwardly toward the shaft axis SA and can flex outwardly away from the shaft axis SA when a force is applied thereto. The elongate shaft 70260 further comprises a top notch 70262a and a bottom notch 70262b opposing the top notch 70262a. The top notch 70262a and the bottom notch 70262b are located in the distal end of the elongate shaft 70260. The clip cartridge 70270 is releasably attachable to the distal end of the elongate shaft 70260 as discussed in further detail below.

The clip cartridge 70270 comprises a top protrusion 70272a and a bottom protrusion 70272b opposite the top protrusion 70272a. The top protrusion 70272a and the bottom protrusion 70272b extend from the clip cartridge 70270 away from the shaft axis SA. The clip cartridge 70270 further comprises a first slot and a second slot 70274b in the proximal end of the clip cartridge 70270. The first slot and the second slot 70274b oppose one another. The clip cartridge 70270 is configured to slide into the inner diameter of the elongate shaft 70260 such that the top protrusion 70272a slides into the top notch 70262a, the bottom protrusion 70272b slides into the bottom notch 70262b, the first inwardly extending detent 70264a engages the first slot of the clip cartridge 70270, and the second inwardly extending detent 70264b engages the second slot 70274b of the clip cartridge 70270 to attach the clip cartridge 70270 to the elongate shaft 70260. After the clip cartridge 70270 is attached to the elongate shaft 70260, the elongate shaft 70260 and clip cartridge 70270 are fixedly coupled such that they can rotate together about the shaft axis SA. Further, the clip cartridge 70270 can be detached from the elongate shaft 70260 by a clinician when the clinician applies a distal force to the clip cartridge 70270 to disengage the first and second inwardly extending detents 70264a and 70264b of the elongate shaft 70260 from the first slot and the second slot 70274b of the clip cartridge 70270.

Referring primarily to FIGS. 42A and 42B, the end effector 70280 comprises a first jaw 70280a and a second jaw 70280b configured to move relative to each other between an open position (FIG. 42A) and a closed position (FIG. 42B). To this end, the first jaw 70280a and the second jaw 70280b comprise openings at the proximal end thereof which are configured to receive a pin 70290. The pin 70290 is rotatably captured within an opening 70276 in the clip

cartridge 70270. The pin 70290 defines a pin axis PA which is orthogonal to the shaft axis SA. The first jaw 70280a and the second jaw 70280b are rotatable relative to each other about the pin axis PA. When the first jaw 70280a and the second jaw 70280b are in the open position (FIG. 42A) a clip can be positioned between the first jaw 70280a and the second jaw 70280b. As the first jaw 70280a and the second jaw 70280b are r towards the closed position (FIG. 42B) the clip is crimped between the first jaw 70280a and the second jaw 70280b. The first jaw 70280a and the second jaw 70280b are moved from the open position to the closed position by a closure tube which cammingly engages the outer surfaces of the first jaw 70280a and the second jaw 70280b as the closure tube moves distally. When the closure tube is retracted, the first jaw 70280a and the second jaw 70280b are returned to the open position by a biasing member, or spring, which biases the first jaw 70280a and the second jaw 70280b into the open position. Other embodiments are envisioned where the first jaw 70280a and the second jaw 70280b are movable from the closed position to the open position by jaw cams on the first jaw 70280a and the second jaw 70280b interacting with the closure tube, similar to jaw cams 70124a and 70124b depicted in FIGS. 36-38, for example.

FIG. 43A depicts a clip applier 70300 in accordance with at least one embodiment. The clip applier 70300 comprises a shaft 70310, an end effector 70320 extending from the shaft 70310, a firing drive, and a clip magazine 70306. The clip magazine 70306 is built into the shaft 70310 of the clip applier 70300 as depicted in FIG. 43A. However, other embodiments are envisioned where the clip magazine 70306 is releasably attachable to the clip applier 70300. The shaft 70310 comprises openings 70308 on either side of the shaft 70310 which allow a user of the clip applier 70300 to access the clip magazine 70306. Other embodiments are envisioned with only one opening in the shaft 70310 of the clip applier. The clip applier 70300 further comprises an outer tube 70302 that is slidable along the shaft 70310 of the clip applier 70300. The outer tube 70302 is configured to slide along the shaft 70310 to cover the openings 70308 in the shaft 70310. The clip magazine 70306 is configured to store a plurality of clips, such as clips 70304 therein. The clips 70304 are insertable into the clip magazine 70306 through the openings 70308 when the outer tube 70302 is not obstructing the openings 70308, as depicted in FIG. 43A. Once positioned in the clip magazine 70306, the clips 70304 can be advanced out of the clip magazine 70306 into the end effector 70320 by the firing member. In at least one embodiment, the clips 70304 can be sequentially advanced out of the clip magazine 70306 into the end effector 70320.

When the outer tube 70302 is covering the openings 70308, access to the clip magazine 70306 is prevented, and, if clips 70304 have already been inserted into the clip magazine 70306, the outer tube 70302 prevents the clips 70304 from exiting the clip magazine 70306 through the openings 70308. Once all of the clips 70304 inside the clip magazine 70306 have been advanced into the end effector 70320, the outer tube 70302 can be retracted to allow a new set of clips to be inserted into the clip magazine 70306. Further to the above, the outer tube 70302 can be operably engaged with the firing member of the clip applier 70300, such that, when the outer tube 70302 is retracted as depicted in FIG. 43A, or at least partially retracted, the firing member cannot be actuated.

FIG. 44 depicts a clip applier 70300'. Clip applier 70300' is similar to clip applier 70300 in many respects. The clip applier 70300' comprises an elongate shaft 70315 extending

from a housing, an articulation joint 70314 extending from the elongate shaft 70315, a shaft assembly 70310' extending from the articulation joint 70314, an end effector 70320 extending from the shaft assembly 70310', and an outer tube 70302' positioned around the shaft assembly 70310'. The articulation joint 70314 connects the elongate shaft 70315 to the shaft assembly 70310' so that the shaft assembly 70310' can be articulated relative to the elongate shaft 70315. The shaft assembly 70310' comprises a proximal shaft portion 70311 extending from the articulation joint 70314, a distal shaft portion 70312 extending from the proximal shaft portion 70311, and a hinge 70307. The distal shaft portion 70312 further comprises a clip magazine 70306'. Other embodiments are envisioned where the proximal shaft portion 70311 comprises the clip magazine 70306'. The hinge 70307 allows the distal shaft portion 70312 to rotate away from the proximal shaft portion 70311. The outer tube 70302' is configured to slide along the shaft assembly 70310' between a locked position and an unlocked position when the proximal shaft portion 70311 and distal shaft portion 70312 are aligned. More specifically, when the proximal shaft portion 70311 and distal shaft portion 70312 are aligned and the outer tube 70302' is in the locked position, the distal shaft portion 70312 is prevented from rotating away from the proximal shaft portion 70311 about the hinge 70307. When the outer tube 70302' is in the unlocked position, the distal shaft portion 70312 is capable of rotating away from the proximal shaft portion 70311 about the hinge 70307. Further to the above, when the distal shaft portion 70312 is rotated away from the proximal shaft portion 70311, an opening 70308' in the clip magazine 70306' is exposed. The opening 70308' allows clips 70304' to be inserted into the clip magazine 70306'.

Further to the above, a clip reloader 70350 can be utilized to insert the clips 70304' into the clip applicator 70300' as depicted in FIG. 44. The clip reloader comprises a housing 70352, a trigger 70354 movable relative to the housing 70352, a feeder bar operably engaged with the trigger 70354, an elongate shaft 70356 extending from the housing 70352, and a docking station 70360 extending from the elongate shaft 70356. A plurality of clips 70304' are removably stored in the elongate shaft 70356. In one embodiment, the elongate shaft 70356 stores 20 clips within a six inch span of the elongate shaft 70356. Other embodiments are envisioned with different numbers of clips and spans, for example. The clips 70304' are advanced from the elongate shaft 70356 into the docking station 70360 by the feeder bar when the trigger 70354 is moved towards the housing 70352. The docking station 70360 comprises a cavity 70358 configured to dock with the shaft assembly 70310' of the clip applicator 70300' when the distal shaft portion 70312 is rotated away from the proximal shaft portion 70311. When the docking station 70360 is docked with the shaft assembly 70310' of the clip applicator 70300', the clips 70304' can be advanced from the elongate shaft 70356 into the clip magazine 70306' of the clip applicator.

FIGS. 45-47 depict a different clip reloader 70400. The clip reloader 70400 is similar to the clip reloader 70350 in many respects. The clip reloader 70400 comprises a housing 70410, a plurality of clips 70404 stored inside the housing 70410, and a plunger 70402. The plunger 70402 extends into and is movable relative to the housing 70410. The clips 70404 are stacked vertically in the embodiment illustrated in FIGS. 45 and 46; however, other embodiments are envisioned where the clips are stacked horizontally. A feeder block 70406 extends from the plunger 70402 and is slidably engaged with the inside of the housing 70410. The feeder

block 70406 comprises angled portions that support the backside of the top-most clip in the clip stack as depicted in FIG. 45. The housing 70410 comprises a boss 70408 extending from the bottom of the housing 70410, and a flexible ramp 70409 extending from the bottom of the boss 70408. The housing 70410 further comprises a cutout region 70411. Docking the clip reloader 70400 with a clip applicator is discussed in further detail below.

In various circumstances, the clip reloader 70400 is configured to insert the clips 70404 into a clip applicator, such as clip applicator 70450, for example. The clip applicator 70450 comprises a shaft 70460, an end effector 70480 extending distally from the shaft 70460, and an articulation joint 70470 extending proximally from the shaft 70460. To align the clip reloader 70400 with the clip applicator 70450, the boss 70408 docks with an opening 70464 in the shaft 70460 of the clip applicator 70450, the cutout region 70411 mates with the exterior of the shaft 70460, and the flexible ramp 70409 extends into a clip slot 70462 of the clip applicator 70450 as depicted in FIG. 47. The opening 70464 leads to the clip slot 70462 which comprises an angled portion that receives the boss 70408 and flexible ramp 70409 of the clip reloader 70400. The clip slot 70462 further comprises a flat portion that facilitates the advancement of the clips 70404 into the end effector 70480 of the clip applicator 70450. The operation of the clip reloader 70400 in conjunction with the clip applicator 70450 is discussed in further detail below.

In use, after the clip reloader 70400 is docked with the clip applicator 70450, the plunger 70402 is moved towards the clip applicator 70450 to advance the clips 70404 from the housing 70410 into the angled portion of the clip slot 70462. The ramp 70409 supports and guides the clips 70404 from the angled portion of the clip slot 70462 into the flat portion of the clip slot 70462. As illustrated in FIG. 47, the housing 70410 of the clip reloader 70400 is positioned at an angle relative to the longitudinal axis of the clip applicator 70450 when the clip reloader 70400 is docked with the clip applicator 70450. Other embodiments are envisioned where the housing 70410 is orthogonal, or at least substantially orthogonal, to the clip applicator 70450 when docked. Referring primarily to FIG. 47, the clip applicator 70450 further comprises a flexible firing member 70465 positioned within a firing slot 70466 located proximal to the clip slot 70462. After the clip reloader 70400 is un-docked with the clip applicator 70450, the flexible firing member 70465 can move from the firing slot 70466 into the clip slot 70462 to advance the clips 70404 into the end effector 70480. Once at least one, or all, of the clips 70404 have been advanced into the end effector 70480, the flexible firing member 70465 can be retracted from the clip slot 70462 into the firing slot 70466 and additional clips 70404 can be loaded into the clip slot 70462 by the clip reloader 70400.

FIGS. 48-50 depict a clip applicator 70500. The clip applicator 70500 comprises an elongate shaft 70570 (see FIG. 50) extending from a housing, a shaft 70510 attachable to the elongate shaft 70570, an end effector 70520 extending from the shaft 70510, and a clip magazine 70530. The attachable shaft 70510 comprises an upper pivot link 70512 and a lower pivot link 70514 extending distally therefrom. The end effector 70520 comprises a first jaw 70521a and a second jaw 70521b movable relative to each other between an open position and a closed position about a pivot pin 70511. The pivot pin 70511 is constrained within openings in the upper pivot link 70512 and the lower pivot link 70514 of the shaft 70510. The clip magazine 70530 is removably positioned within the attachable shaft 70510 and comprises a plurality of clips 70532. The clip applicator 70500 further comprises a

closure system **70540** and a firing system **70550**. The closure system **70540** and the firing system **70550** are discussed in greater detail below.

The closure system **70540** comprises a proximal closure driver **70542** comprising a threaded portion **70543**, a distal closure driver **70566** comprising a closure nut **70544**, an upper closure hinge **70545a**, and a lower closure hinge **70545b**. The proximal closure drive **70542** is configured to rotate in response to rotary motions generated inside the housing of the clip applicator. The closure drive **70542** transmits rotational motion to the threaded portion **70543** which is threadably received in the closure nut **70544**. The closure drive **70542** can comprise a flexible portion to facilitate the transfer of rotational motion to the closure nut **70544**. The closure nut **70544** is rotatably constrained within the shaft **70510** such that rotation of the threaded portion **70543** in a first direction will result in translation of the nut **70544** distally, and rotation of the threaded portion **70543** in a second direction—opposite the first direction—will result in translation of the nut **70544** proximally. The distal closure driver **70566** extends from the closure nut **70544** and attaches to the upper closure hinge **70545a** and the lower closure hinge **70545b** via a closure pin **70547**. The closure pin **70547** allows the upper and lower closure hinges **70545a** and **70545b** to translate distally and proximally with the distal closure driver **70566** while still being rotatable about the closure pin **70547**. Further to the above, the upper closure hinge **70545a** is rotatably engaged with a proximal portion **70523a** of the first jaw **70521a**, and the lower closure hinge **70545b** is rotatably engaged with a proximal portion **70523b** of the second jaw **70521b**. As illustrated in FIG. **48**, the first jaw **70521a** and the second jaw **70521b** cross over each other about the pivot pin **70511** in a scissor like formation. Such an arrangement allows the first jaw **70521a** and the second jaw **70521b** to move toward the open position when the upper and lower closure hinges **70545a** and **70545b** are translated distally by the closure system **70540**, and allows the first jaw **70521a** and the second jaw **70521b** to move toward the closed position when the upper and lower closure hinges **70545a** and **70545b** are translated proximally by the closure system **70540**.

The clip applicator **70500** further comprises a firing system **70550** comprising a firing member **70560**. The firing member **70560** is translatable through the end effector between an unfired position and a fired position in response to the rotary motions that drive the closure system **70540**. Other embodiments are envisioned where the closure system **70540** and the firing system **70550** are operated by two separate motors within the housing of the clip applicator, for instance. The firing member **70560** is configured to advance a clip **70532** from the clip magazine **70530** into the first and second jaws **70521a** and **70521b** of the clip applicator **70500**. As illustrated in FIG. **49**, the clip magazine **70530** is at least partially supported by the closure system **70540**. More specifically, a biasing member, such as leaf spring **70546**, for example, biases the clips **70532** toward the firing member **70560** and holds the clip magazine **70530** in position. Other embodiments are envisioned where the closure system **70540** can align, and/or guide, and/or lock the clip magazine **70530** into place within the shaft **70510**. The embodiment depicted in FIGS. **48** and **49** illustrates the closure system **70540** arranged around the clip magazine **70530** to allow a larger space inside the shaft **70510** for the clip magazine **70530** and clips **70532**; however, a closure system can have any suitable arrangement. The closure system **70540** is discussed in further detail below.

The threaded portion **70543** and closure nut **70544** of the closure system **70540** allows for a more precise actuation of the first and second jaws **70521a** and **70521b** when moving between the open position and the closed position as compared to previous clip applicator arrangements that utilize a translating closure tube or cam member. Rotary encoders and/or other sensors can be used in combination with the closure system **70540** to provide even greater accuracy in determining the position of the first and second jaws **70521a** and **70521b**.

Turning now to FIG. **50**, the clip applicator **70500** further comprise protrusions **70513** and **70516** extending from the proximal end of the shaft **70510**. The protrusions **70513** and **70516** may be the same shape or different shapes. The protrusions **70513** and **70516** are configured to lockingly engage slots **70572a** and **70572b** in the elongate shaft **70570** of the clip applicator **70500** to form a bayonet connection therebetween. The slots **70572a** and **70572b** comprise L-shaped portions that lock the protrusions **70513** and **70516** into place when the shaft **70510** is inserted into and then rotated relative to the elongate shaft **70570**. FIG. **50** further depicts a clip **70532** located within the first jaw **70521a** and the second jaw **70521b**. The clip **70532** and other embodiments of clips for use with a clip applicator, such as clip applicator **70500**, are discussed in further detail below.

Turning now to FIGS. **51A** and **51B**, the clip **70532** comprises a base portion **70534**, a first leg **70534a** extending from the base portion **70534**, and a second leg **70534b** extending from the base portion **70534** and opposing the first leg **70534a**. The base portion **70534** can comprise a flexible material, such as plastic and/or any other suitable flexible material, to allow the clip **70532** to flex between multiple positions without breaking or becoming plastically deformed in an unsuitable manner. For example, the clip **70532** can be moved between a magazine storage configuration, a pre-firing configuration, and a post-firing configuration as depicted in FIG. **51B**. The first leg **70534a** comprises a reinforced region comprising a ridge **70535a**, and the second leg **70534b** comprises a reinforced region comprising a ridge **70535b**. The ridges **70535a** and **70535b** extend along at least a portion of the first leg **70534a** and the second leg **70534b**, respectively. The ridges **70535a** and **70535b** act as a rigid backbone to prevent, or at least substantially reduce, the deformation of the first leg **70534a** and the second leg **70534b** during crimping. Other embodiments are envisioned where only one of the first leg **70534a** and the second leg **70534b** comprises a ridge. The ridges **70535a** and/or **70535b** may be comprised of a rigid material, such as a fiberglass-filled and/or particle-filled plastic, for example, to prevent, or at least reduce, deflection of the first leg **70534a** and/or the second leg **70534b** when the clip **70532** is crimped. The clip **70532** further comprises a locking portion, such as tooth **70536**, for example, extending from a portion of the first leg **70534a**. The tooth **70536** lockingly engages the edges of an opening, or window, **70537** in the second leg **70534b** when the clip **70532** is crimped (see the post-firing configuration in FIG. **51B**). Such an arrangement allows the clip **70532** to stay in a crimped state after the clip **70532** has been released from the jaws of a clip applicator. Further, the clip **70532** includes grip features, such as protrusions **70538**, extending from the inside surfaces of the first and second legs **70534a** and **70534b**. The protrusions **70538** engage tissue clamped between the first and second legs **70534a** and **70534b** when the clip **70532** is crimped. The protrusions **70538** prevent, or at least substantially reduce, the movement of the tissue relative to the clip **70532** after the clip **70532** is crimped.

around the tissue. The protrusions **70538** may be any number of shapes and sizes, such as pyramidal shapes, conical shapes, frustoconical shapes, for example, and/or any other suitable shape.

Turning now to FIGS. **51C-51F**, a different clip **70580** for use with a clip applier is depicted. The clip **70580** is similar to clip **70532** in many respects. That said, the base **70534** of the clip **70580** comprises a stress relief notch **70588** on the side of the base **70534** opposite the first and second legs **70534a** and **70534b**. In use, the stress relief notch **70588** allows the first and second legs **70534a** and **70534b** to flex inwardly and then outwardly a number of times without being plastically deformed in an unsuitable manner. However, in various circumstances, the clip **70580** can be configured to yield, or deform plastically, when the clip **70580** is sufficiently compressed. Such designed or controlled yielding, in various instances, can help the clip **70580** fold into the desired shape.

FIGS. **52-60** depict a clip applier **70600**. Turning now to FIG. **53**, the clip applier **70600** comprises a shaft **70610** extending from a housing, an end effector **70605** extending from the shaft **70610**, and a rotatable clip magazine **70650**. The end effector **70605** comprises a first jaw and a second jaw that are movable relative to each other between an open position and a closed position, similar to the first jaw **70123a** and the second jaw **70123b** of the clip applier **70100** discussed above. The rotatable clip magazine **70650** is rotatably and slidably supported within the clip applier **70600**. More specifically, the rotatable clip magazine **70650** is rotatable about shaft axis SA and translatable along shaft axis SA. The shaft axis SA is defined by the shaft **70610**. Further detail regarding how the clip magazine **70650** is supported within the clip applier **70600** is provided below.

Referring to FIG. **52**, the rotatable clip magazine **70650** comprises a body portion **70652** including five sides, each of which comprises a clip channel **70656** configured to removably store a clip **70654** therein. The body portion **70652** further comprises an opening **70653** that extends through the body portion **70652**. In the illustrated embodiment, the body portion **70652** is pentagonal in shape, for example; however, other embodiments are envisioned in which the opening **70653** comprises different shapes to allow for more than or less than five clip channels **70656** and, therefore, more than or less than five clips **70654** stored in the rotatable clip magazine **70650**. In at least one embodiment, the clips **70654** comprise a clip width of 0.080", a clip thickness of 0.03", and a clip length of 0.310" (for a Lig 5 Clip) or 0.315" (for an ER320 Clip), for example; however, clips having any suitable size can be used. Moreover, it is envisioned that the clips stored in the clip magazine **70650** will have the same, or at least substantially the same size; however, alternative embodiments are envisioned in which clips having different sizes may be stored in the same clip magazine. Further, in at least one embodiment, the overall diameter of the entire rotatable clip magazine **70650** is 0.996", for example; however, the clip magazine **70650** can have any suitable diameter—including diameters which can permit the clip magazine **70650** to be inserted through a trocar. The rotatable clip magazine **70650** further includes a clocking portion, such as teeth **70658**, for example, extending proximally from the clip magazine **70650**. The clip applier **70600** comprises several drives and drivers which define the motion and/or operating sequence of the clip applier **70600**, as described in further detail below.

Referring again to FIG. **53**, the clip applier **70600** further comprises a closure tube **70620**, a feeder member **70630**, and a firing member **70640**. The closure tube **70620** com-

prises a closure drive **70625** extending proximally from the closure tube **70620**. The closure drive **70625** extends through the opening **70653** in the clip magazine **70650** and is operably engaged with an actuator inside the housing of the clip applier **70600**. The clip magazine **70650** is supported on at least a portion of the closure drive **70625**. The closure tube **70620** is at least partially supported and aligned within a recess in the shaft **70610**. The closure tube **70620** is movable between a plurality of positions, such as a fully retracted position, a home position, and a fully advanced position (see FIGS. **53** and **54A**). Similar to the crimping drive **70180** of the clip applier **70100**, the closure tube **70620** is configured to move the first jaw and the second jaw of the end effector **70605** toward and away from each other. When the closure tube **70620** moves distally, the closure tube **70620** cammingly engages the first and second jaws to move the first and second jaws to the closed position and, when the closure tube **70620** moves proximally, the closure tube **70620** engages jaw cams on each of the first and second jaws to move the first and second jaws to the open position. That said, any suitable jaw opening and closing arrangement could be used.

The feeder member **70630** is aligned with one of the clip channels **70656** of the rotatable clip cartridge **70650**, and is configured to advance a clip **70654** out of the clip channel **70656** that is aligned with the feeder member **70630** toward the end effector **70605**. The feeder member **70630** is translatable linearly through the clip applier **70600** by a feeder gear **70638** and a feeder drive **70635** which are operably engaged with a rack portion of the feeder member **70630**. The feeder drive **70635** comprises a pinion gear **70637** at the distal end thereof which is operably engaged with the feeder gear **70638** such that, as the feeder drive **70635** is rotated, the feeder member **70630** is translated linearly through the clip applier **70600**. The feeder drive **70635** is operably engaged with a first motor inside the housing of the clip applier **70600**. The first motor transmits rotational motion to the feeder drive **70635**. Similar to the operation of the feeder member **70630**, the firing member **70640** is translatable linearly through the clip applier by a firing gear **70648** and a firing drive **70645** which are operably engaged with a rack portion of the firing member **70640**. The firing drive **70645** comprises a pinion gear **70647** on the distal end thereof which is engaged with the firing gear **70648** such that, as the firing drive **70645** is rotated, the firing member **70640** is translated linearly through the clip applier **70600**. Further, the firing drive **70645** is operably engaged with a second motor inside the housing of the clip applier **70600**. The second motor transmits rotational motion to the firing drive **70645**. Other embodiments are envisioned where the feeder drive **70635** and the firing drive **70645** are rotatable by the same motor utilizing a transmission. Further, other embodiments are envisioned, and are described further below, where the feeder member **70630** and the firing member **70640** translate together through the clip applier **70600**. Operation of the feeder member **70630** and firing member **70640** are also described in greater detail below.

Referring primarily to FIG. **53**, the firing member **70640** comprises a distal portion **70640a** extending therefrom that is configured to advance a clip **70654** into the end effector. The shaft **70610** further includes a ground portion **70612** mounted to the shaft **70610** and aligned with the clip magazine **70650**. The ground portion **70612** is mounted to the shaft **70610** such that the ground portion **70612** is not movable, translatable, and/or rotatable relative to the shaft **70610**. The ground portion **70612** includes a clocking portion, such as teeth **70614**, for example, extending distally

therefrom as illustrated in FIG. 54B. The teeth 70614 of the ground portion 70612 are aligned, or at least substantially aligned, with the teeth 70658 of the rotatable clip magazine 70650. Further, the ground portion 70612 supports a biasing member, such as spring 70616, for example, thereon. The spring 70616 biases the clip magazine 70650 distally toward the closure tube 70620 and the end effector 70605, as illustrated in FIG. 54A. Other embodiments are envisioned where the spring comprises a leaf spring and the clip applier 70600 further comprises a track and the leaf spring can be configured to both index the clip magazine 70650 and prevent the clip magazine 70650 from counter rotation. In any event, the rotation of the clip magazine 70650 about the shaft axis SA and translation of the clip magazine 70650 along shaft axis SA is described in further detail below.

Referring primarily to FIG. 52, the closure tube 70620 includes clocking channels 70622 located radially around the closure drive 70625. The closure drive 70625 rotatably and slidably supports the rotatable clip magazine 70650 thereon as discussed above. The clocking channels 70622 are engaged with protrusions within the opening 70653 of the clip magazine 70650 to rotatably lock the clip magazine 70650 into place relative to the closure tube 70620 when the closure tube is in the home position or the fully advanced position. When the closure tube 70620 is moved to the fully retracted position, as illustrated in FIG. 53, the spring 70616 moves/biases the clip magazine 70650 toward the closure tube 70620 resulting in the clocking channels 70622 becoming disengaged from the protrusions within the opening 70653 of the clip magazine 70650. As such, the clip magazine 70650 can rotate freely about shaft axis SA. Further, when the closure tube 70620 is moved to the fully retracted position, the teeth 70658 of the clip magazine 70650 engage the teeth 70614 of the ground portion 70612 to rotate (i.e., cycle) the clip magazine 70650. More specifically, the teeth 70658 and the teeth 70614 are structured to rotate the clip magazine 70650 about the shaft axis SA a predefined amount of degrees based on the spacing and angles of the teeth 70658 relative to the teeth 70614. The reader will appreciate that the spacing and angles of the teeth 70658 relative to the teeth 70614 can be designed to generate a suitable degree of rotation for the clip magazine 70650 about shaft axis SA. In the embodiment depicted in FIGS. 52-54A, the teeth 70658 and the teeth 70614 are spaced and aligned such that, when they are engaged, the clip magazine 70650 rotates 72 degrees to align an adjacent clip 70654 with the feeder member 70630. After the clip magazine 70650 is cycled, the closure tube 70620 can be moved distally from the fully retracted position to the home position (FIG. 54A) resulting in the clocking channels 70622 engaging the protrusions in the opening 70653 of the clip magazine 70650 to lock the rotation of the clip magazine 70650 as discussed above. Usage of the clip applier 70600 to advance, form, and fire a clip 70654 is describe in further detail below.

As mentioned above, the feeder member 70630 and firing member 70640 can be translatable together. For simplicity, FIGS. 55-60 illustrate the functions of clip applier 70600 where the feeder member 70630 and firing member 70640 move together to feed and fire a clip 70654 from the rotatable clip magazine 70650. Turning now to FIGS. 55 and 56, a clip 70654 is advanced from the rotatable clip magazine 70650 into engagement with a biasing member, such as a leaf spring 70624, for example, of the closure tube 70620 by the feeder member 70630. The leaf spring 70624 biases and guides the clip 70654 onto the top of the firing member 70640, as illustrated in FIG. 56. When the firing member 70640 and feeder member 70630 are retracted, the clip

70654 is moved further downward by the leaf spring 70624 and seated around pre-form features, such as protrusions 70608, for example, depicted in FIG. 57. Protrusions 70608 can be similar to protrusions 70126a and 70126b described above (See FIGS. 35A and 35B). One protrusion 70608 is located on one jaw of the end effector 70605, and another protrusion 70608 is located on another jaw of the end effector 70605.

When the closure tube 70620 is in the fully retracted position, referring to FIG. 58, the jaws of the clip applier 70600 are in the open position and the protrusions 70608 expand the clip 70654 from a storage configuration into a firing configuration—similar to the expansion of clip 70140 described above in connection with FIGS. 35A and 35B. When the closure tube 70620 is moved to the fully retracted position, as described above, the rotatable clip magazine 70650 is rotated (i.e., cycled) about the shaft axis SA to position another clip 70654 into alignment with the feeder member 70630. Turning to FIG. 59, the firing member 70640 can be moved toward the end effector 70605 to advance the clip 70654 over the protrusions 70608 and into the end effector 70605. As discussed above in connection with protrusions 70126a and 70126b, the protrusions 70608 can comprise angled portions that allow the clip 70654 to slide over the protrusions 70608 when advanced distally by the firing member 70640. Once the clip 70654 is positioned in the end effector 70605, the closure tube 70620 can be moved to the fully advanced position (FIG. 60) to move the jaws from the open position to the closed position to crimp the clip 70654 positioned between the jaws.

Because the feeder member 70630 and the firing member 70640 translate together, further to the above, the feeder member 70630 advances another clip 70654 (i.e., the clip that was rotated into position when the closure tube 70620 was fully retracted) from the clip cartridge 70650 down onto the firing member 70654 with the aid of the leaf spring 70624, as discussed above, when the firing member 70640 advances a clip 70654 into the end effector 70605. Again, the firing member 70640 and the feeder member 70630 can be retracted to allow the new clip 70654 to be biased downward by the leaf spring 70624 and seated around the protrusions 70608. The new clip 70654 can then be expanded to the firing configuration as clip magazine 70650 is cycled, and then the new clip 70654 can be advanced into the end effector 70605 for crimping as discussed above. The process discussed above can be repeated until the clip magazine 70650 has been spent. The reader will appreciate that the closure tube 70620 can be moved between the home position (FIGS. 56 and 57) and the fully advanced position (FIG. 60) to crimp and release a clip 70654 within the end effector 70605 without cycling the clip magazine 70650. This allows the jaws of the end effector 70605 to move between the open and closed positions without cycling the clip magazine 70650 and/or ejecting another clip from the clip magazine 70650.

FIG. 61 depicts a clip applier 70700 in accordance with at least one embodiment. The clip applier 70700 comprises a shaft 70710 extending from a housing, an end effector 70705 extending from the shaft 70710, and a clip cartridge 70720 that is releasably attachable to the clip applier 70700. The end effector 70705 comprises a first jaw and a second jaw movable relative to each other, similar to the first and second jaws 70123a and 70123b discussed above. The clip applier 70700 further comprises a firing system 70730 that comprises a rotatable drive 70732 which is operably responsive to a motor inside the housing of the clip applier 70700. The rotatable drive 70732 comprises a threaded portion. The

firing system 70730 further includes a firing member 70736 and a firing nut 70734. The firing nut 70734 is threadably received on the threaded portion of the rotatable drive 70732. The firing nut 70734 is rotatably constrained within the clip applier 70700 such that the rotation of the rotatable drive 70732 translates the firing nut 70734 through the clip applier 70700. The firing member 70736 is engaged with the firing nut 70734 and translates into the first and second jaws of the end effector 70705 in response to translation of the firing nut 70734 by the rotatable drive 70732. Attachment of the clip cartridge 70720 to the clip applier 70700 is described in greater detail below.

The clip applier 70700 further comprises a docking region, or recess 70714, in the distal end of the clip applier 70700, as illustrated in FIG. 61. The clip cartridge 70720 comprises a body portion 70722 that is slidably receivable in the recess 70714 of the clip applier 70700. A locking feature 70728 extends proximally from the clip cartridge 70720. The locking feature 70728 includes an angled surface 70728a at the proximal end thereof and a detent 70728b extending downwardly, although the locking feature 70728 can include any suitable arrangement. The locking feature 70728 engages a protrusion 70712 of the shaft 70710 when the clip cartridge 70720 is docked within the recess 70714. More specifically, the angled surface 70728a slides over the protrusion 70712 and the downwardly extending detent 70728b locks into place proximal to the protrusion 70712, thus locking the clip cartridge 70720 to the clip applier 70700. In such instances, the locking feature 70728 deflects as the angled surface 70728a slides over the protrusion 70712 and then resiliently returns to, or at least toward, its undeflected configuration, when the detent 70728b locks into place. A sufficient distal pulling motion can cause the locking feature 70728 to deflect and release the clip cartridge 70720 from the clip applier 70700. Operation of the clip applier 70700 is described in further detail below.

The clip cartridge 70720 further comprises a ramp portion 70721, a plurality of clips 70724 positioned in a stack, and biasing members, such as springs 70726, for example. The clips 70724 are biased toward the ramp portion 70721 by the springs 70726. In fact, the top clip 70724 in the stack of clips is biased into the ramp portion 70712 by the springs 70726. When the clip cartridge 70720 is docked with the clip applier 70700, as discussed above, the ramp portion 70721 aligns with a feeder drive 70740 of the clip applier 70700. The feeder drive 70740 is operably responsive to an actuator within the housing of the clip applier 70700. The feeder drive 70740 is configured to reciprocatingly actuate into the ramp portion 70721. To accommodate an angled portion within the ramp portion 70721 the feeder drive 70740 can be flexible. The feeder drive 70740 feeds the top clip 70724 in the stack of clips through the ramp portion 70721 and into the end effector 70705. Once in the end effector 70705, the clip 70724 can be advanced further distally into the first and second jaws of the end effector 70705 by translation of the firing member 70736, as discussed above. Once located in the first and second jaws, the clip 70724 can be crimped by a crimping drive. The feeder drive 70740 can be retracted, allowing another clip 70724 to be biased into the ramp portion 70721. The feeder drive 70740 can advance the new clip 70724 through the ramp portion 70721 and into the first and second jaws of the end effector 70705 as discussed above. The process discussed above can be repeated until all of the clips 70724 in the clip cartridge 70720 have been depleted, and/or until a suitable number of clips have been applied to the tissue.

FIG. 62A depicts a clip applier system 70750 in accordance with at least one embodiment. The clip applier system 70750 comprises a shaft 70760 extending from a housing, the clip applier 70250 depicted in FIG. 42 positioned at least partially within the shaft 70760, and the rotatable clip magazine 70650 depicted in FIGS. 52-60 positioned within the shaft 70760. A feeder member is configured to advance the clips 70654 from the rotatable clip magazine 70650—one at a time—into the first and second jaws 70280a and 70280b of the clip applier 70250. Once located within the first and second jaws 70280a and 70280b, the clip 70654 can be crimped as discussed above in relation to FIGS. 42A and 42B. Once the clip 70654 is crimped, the rotatable clip magazine 70650 can be cycled (i.e., rotated) to position another clip 70654 for advancement into the first and second jaws 70280a and 70280b of the clip applier 70250 by the feeder member. This process can continue until all of the clips 70654 in the rotatable clip magazine 70650 have been spent. After all of the clips 70654 have been spent, the rotatable clip magazine 70650 can be replaced with another rotatable clip magazine 70650 containing a full complement of clips 70650. Other embodiments are envisioned where the spent rotatable clip magazine 70650 can be detached from the clip applier system 70750, reloaded with clips 70650, and then re-attached to the clip applier system 70750 for further use.

Turning now to FIGS. 63A and 63B, an articulation joint 70800 for use with a clip applier is illustrated. The articulation joint 70800 releasably couples a clip cartridge 70820 to a shaft 70810 of a clip applier. The shaft 70810 comprises an articulation pivot, or pivot pin 70814, extending from the inside of the shaft 70810. The pivot pin 70814 comprises a base portion 70817, a first leg 70814a extending from the base portion 70817, and a second leg 70814b extending from the base portion 70817 and opposing the first leg 70814a. The first and second legs 70814a and 70814b extend away from each other. The first leg 70814a comprises a first detent, or shoulder, 70816a extending outwardly from the first leg 70814a, and the second leg 70814b comprises a second detent, or shoulder, 70816b extending outwardly from the second leg 70814b. The clip cartridge 70820 comprises a first opening 70822 and, also, a second opening 70824 positioned adjacent and lateral to the first opening 70822. The first opening 70822 is centered in the clip cartridge 70820 and rotatably receives the pivot pin 70814 when the clip cartridge 70820 is attached to the shaft 70810. The first leg 70814a and the second leg 70814b flex towards each other when the first opening 70822 is slid onto the pivot pin 70814 due to angled surfaces at the end of each of the first leg 70814a and second leg 70814b (See FIG. 63B). As the first leg 70814a and second leg 70814b flex toward each other, the pivot pin 70814 can slide through the first opening 70822 until the first and second detents 70816a and 70816b clear the first opening 70822, as illustrated in FIG. 63B. Once the first and second detents 70816a and 70816b clear the first opening 70822, the first and second legs 70814a and 70814b can expand to lock the clip cartridge 70820 to the pivot pin 70814. More specifically, the bottom surfaces of the first and second detents 70816a and 70816b rest on an outer surface 70826 of the clip cartridge 70822 preventing the clip cartridge 70820 from being detached from the pivot pin 70814 unless a sufficient force is applied that exceeds a predetermined, or designed, force threshold. The reader will appreciate that, with force, a user of the clip applier can attach and detach the clip cartridge 70820 to the shaft 70810. Articulation of the clip cartridge about the pivot pin 70814 is described in further detail below.

The clip applier depicted in FIGS. 63A and 63B further comprises a rotatable output 70830 that is operably responsive to a motor located within the housing of the clip applier. The rotatable output 70830 is threadably engaged with a threaded portion 70834 of an articulation bar 70832. Rotation of the rotatable output 70830 in a first direction translates the articulation bar 70832 distally, and rotation of the rotatable output 70830 in a second, or opposite, direction translates the articulation bar 70832 proximally. The articulation bar 70832 comprises a downwardly extending protrusion 70836 that is slidably received in a slot 70812 defined in the shaft 70810. The protrusion 70836 and slot 70812 guide the articulation bar 70832 as the articulation bar 70832 translates and limit relative lateral motion between the articulation bar 70832 and the shaft 70810. The articulation bar 70832 further comprises an upwardly extending protrusion 70838 which is received in the second opening 70824 of the clip cartridge 70820 when the clip cartridge 70820 is attached to the shaft 70810. In use, the distal translation of the articulation bar 70832 will rotate the clip cartridge 70820 about the pivot pin 70814 in a first direction and the proximal translation of the articulation bar 70832 will rotate the clip cartridge 70820 about the pivot pin 70814 in a second, or opposite, direction. The articulation bar 70832 can be flexible to allow the articulation bar 70832 to flex as needed when the clip cartridge 70820 is articulated about the pivot pin 70814.

FIG. 64 depicts a clip applier 70900 in accordance with at least one embodiment. The clip applier 70900 comprises an elongate shaft 70910, an articulation joint 70920, and a distal head 70930. The articulation joint 70920 extends from the elongate shaft 70910 and the distal head 70930 extends from the articulation joint 70920. The distal head 70930 comprises a distal shaft 70932 attached to the articulation joint 70920, an end effector 70936 including a first jaw 70936a and a second jaw 70936b, and a clip cartridge 70934. The first jaw 70936a and second jaw 70936b are movable relative to each other between open and closed positions by any suitable drive system, such as the drive systems disclosed herein, for example. The clip cartridge 70934 stores a plurality of clips which can be advanced into the end effector 70936 and crimped by the first jaw 70936a and the second jaw 70936b. The clip cartridge 70934 is removably attachable to the distal shaft 70932 via a keying arrangement 70938. Other embodiments are envisioned where the clip cartridge 70934 is not removably attachable to the distal shaft 70932. The elongate shaft 70910 defines a first roll axis RA₁ and the distal head 70930 defines a second roll axis RA₂. The elongate shaft 70910 and the distal head 70930 are articulable relative to each other about articulation axis AA via the articulation joint 70920. The arrangement depicted in FIG. 64 is attachable—via the elongate shaft 70910—to a plurality of clip applier handle types, such as, a standard handle (i.e., a wand grip) and/or a pistol grip handle, for example. Depending on the type of handle that is attached to the elongate shaft 70910, different actuations of, or within, the handle may perform different actuations of the arrangement depicted in FIG. 64 about the first roll axis RA₁, the second roll axis RA₂, and the articulation axis AA. These actuations are described in further detail below.

If the elongate shaft 70910 is attached to a standard handle (i.e., a wand handle), referring still to FIG. 64, the elongate shaft 70910, the articulation joint 70920, and the distal head 70930 are all rotatable about the first roll axis RA₁ by the clinician rotating the wand handle. Further, a rotary knob on the wand handle is operably engaged with the elongate shaft

70910, through an electric motor and/or control system, for example, such that manually rotating the rotary knob will result in the distal head 70930 rotating about the second roll axis RA₂. Further, articulation of the distal head 70930 relative to the elongate shaft 70910 about articulation axis AA is driven by an articulation driver operably engaged with a motor housed within the wand handle, for example. If the elongate shaft 70910 is attached to a pistol grip handle, such as the handle 700 discussed above, for example, the elongate shaft 70910, the articulation joint 70920, and the distal head 70930 are all rotatable about the first roll axis RA₁ by a rotary knob, for example. Further, the distal head 70930 is rotated about the second roll axis RA₂ by a dedicated motor within the pistol grip handle. Further still, articulation of the distal head 70930 relative to the elongate shaft 70910 about articulation axis AA is induced by an articulation driver operably engaged with a motor housed within the pistol grip handle. The reader should appreciate that, depending on the type of handle attached to the arrangement depicted in FIG. 64, rotation of the elongate shaft 70910 about the first roll axis RA₁ can be accomplished by rotating the entire handle manually, rotation of a rotary knob engaged with the elongated shaft, and/or by a dedicated motor inside the handle. Further, the rotation of the distal head 70930 about the second roll axis RA₂ can be accomplished by rotation of a rotary knob engaged within the elongate shaft 70910 or by a dedicated motor inside the handle.

A clip applier jaw assembly 70950, or half of the jaw assembly 70950, and a clip leg 70954 of a clip are illustrated in FIG. 65. As can be seen in FIG. 65, the clip applier jaw assembly 70950 comprises a first jaw 70950a which includes a base 70952, a first leg 70952a extending from the base 70952, and a second leg 70952b extending from the base 70952. The first leg 70952a and second leg 70952b oppose one another and define a receiving area 70953 therebetween. The clip leg 70954 is received in the receiving area 70953 but, notably, part of the clip leg 70954 cross-section is not positioned within the receiving area 70953. Thus, only portions of the clip leg 70954 cross-section are supported by the first jaw 70950a. Other arrangements exist where the receiving area 70953 is substantially the same depth and width as the clip leg 70954 of the clip such that all, or at least substantially all, of the cross-section of the clip leg 70954 is positioned within the receiving area 70953 and supported by the first jaw 70950a.

A clip applier jaw assembly 70960 is depicted in FIG. 66A. The clip applier jaw assembly 70960 comprises a first jaw 70960a which includes a base 70962, a first leg 70962a, a second leg 70962b, and a receiving area 70963 which receives a first clip leg 70964 of a clip. The first leg 70962a of the first jaw 70960a extends from the base portion 70962 beyond the first clip leg 70964 when the first clip leg 70964 is seated in the receiving area 70963. The second leg 70962b of the first jaw 70960a extends from the base portion 70962 and terminates prior to the end of the first clip leg 70964 such that only a portion of the first clip leg 70964 is supported by the second leg 70962b of the first jaw 70960a.

The clip applier jaw assembly 70960 further comprises a second jaw 70960b positioned opposite, or opposing, the first jaw 70960a. The second jaw 70960b comprises a base 70962', a first leg 70962a', a second leg 70962b', and a receiving area 70963' which receives a second clip leg 70964' of the clip. The second jaw 70960b opposes the first jaw 70960a such that the first leg 70962a' of the first jaw 70960a is aligned with the first leg 70962a' of the second jaw 70960b, and the second leg 70962b' of the first jaw 70960a is aligned with the second leg 70962b' of the second

jaw 70960*b*. The second leg 70962*b*' of the second jaw 70960*b* extends from the base portion 70962' beyond the second clip leg 70964' of the clip when the second clip leg 70964' is seated in the receiving area 70963'. Further, the first leg 70962*a*' of the second jaw 70960*b* extends from the base portion 70962' and terminates prior to the end of the second clip leg 70964' such that only a portion of the second clip leg 70964' is supported by the first leg 70962*a*' of the second jaw 70960*b*.

When the first jaw 70962*a* and the second jaw 70962*b* of the clip applier jaw assembly 70960 are in a closed configuration, as depicted in FIG. 66B, the first leg 70962*a* of the first jaw 70960*a* supports the entire first clip leg 70964' of the clip and, also, a portion of the second clip leg 70964' of the clip. Further, the second leg 70962*b*' of the second jaw 70960*b* supports the entire second clip leg 70964' of the clip and, also, a portion of the first clip leg 70964' of the clip. Because the first leg 70962*a* of the first jaw 70960*a* and the second leg 70962*b*' of the second jaw 70960*b* are opposite one another, the cross-sections of the first clip leg 70964' and the second clip leg 70964' are supported by both the first jaw 70960*a* and the second jaw 70960*b*—along at least a portion of the leg lengths. Such an arrangement prevents, or at least inhibits, the clip from twisting when the clip is crimped.

Referring to FIG. 67, the clip leg 70954 is seated within the first clip jaw 70950*a* of the clip applier jaw assembly 70950 but is not prevented from being slid longitudinally within the clip applier jaw assembly 70950. In accordance with at least one embodiment, such as the clip applier jaw assembly 70960, for example, the first jaw 70960*a* and/or the second jaw 70960*b* comprise a clip ejection prevention feature, such as distal stop 70966. The distal stop 70966 prevents the clip 70964 from sliding out of the distal end of the first jaw 70950*a* and/or the second jaw 70950*b* of the clip applier jaw assembly 70960. Other clip applier jaw shapes and guidance features configured to control the position of the clip, and/or prevent the unintentional dropping and/or ejection of the clip from the clip applier, are discussed in greater detail below.

As discussed above, the jaws of a clip applier, or “clip jaws”, are used to deform the clips. As the reader should appreciate, the clip jaws themselves undergo stresses and strains and, in some instances, can be plastically deformed. Clip jaws designed to resist plastic deformation during use may comprise clip jaws which vary in thickness, width, and/or clip path depth along the clip jaw lengths in order to improve the stiffness in a lap clip applier, for example. Further, a proximal portion of one of the clip applier jaws can comprise a protruding bar (i.e., a tongue portion) and a proximal portion of the other clip applier jaw can comprise a recess (i.e., a groove portion) such that the protruding bar is seated in the recess when the clip applier jaws are closed. Such an arrangement provides for superior jaw resilience to vertical skewing and/or twisting of the clip applier jaws relative to each other during crimping of a clip. Improved clip retention structures are discussed in further detail below.

In at least one embodiment, the clip applier jaws may comprise a clip retention channel, or recess, to allow a clip to be advanced into the clip applier jaws via a feeder member from below. The feeder member includes a flexible drive plate that is retracted when the clip applier jaws are actuated (i.e., moved from an open position to a closed position) and is extended into the distal end of the clip applier jaws to hold the clip in a distal position until the clip applier jaws are actuated. Further, the feeding member prevents any further clips from inadvertently advancing into the clip applier jaws until the feeder member is retracted to

retrieve and advance the next clip. Clip applier jaws including a distal retaining feature are discussed in greater detail below.

In at least one embodiment, the clip applier jaws each comprise a distal retaining feature, such as a ledge, for example, that extends above a guidance trough in the clip applier jaws. The guidance trough may comprise retention features, such as recesses, for example, on the distal end thereof which mate with protrusions on the clip to allow the clip to remain in a distal position within the clip applier jaws without needing to be held into place by a firing member and/or feeder member. The construction and manufacturing of certain clip applier jaws is discussed in greater detail below.

In various embodiments, the clip applier jaws are manufactured using a two part method where at least the distal portions of the clip applier jaws are metal injection molded (MIM) within an injection mold. In certain instances, the injection mold comprises two sides which are translatable toward and away from each other along a parting axis and the interface between the two mold halves is often planar, or at least substantially planar, and is often called a “parting plane”. In at least one such instance, the parting plane is perpendicular to the axis of a clip trough of the clip applier jaws formed within the injection mold. Such an arrangement allows stiffening features, such as a rail, for example, to be designed onto the back side of the clip applier jaws, friction or holding features within the clip trough, and/or the distal holding features discussed above, for instance. Using a MIM process may often require the clip applier jaws to be machined, ground, and/or polished, for example, after being removed from the injection mold. The clip applier jaws are then either pivotally pinned together and/or welded pivotally to the connection features of an end effector. By using MIM to produce certain portions of the jaws, the cost to produce the jaws can be reduced as inexpensive manufacturing methods can be utilized for the connection features, as opposed to using MIM to produce the entire clip applier jaws. Further, the clip applier jaws can be independently manufactured using MIM and then welded to a spring based interconnection clip. Moreover, independently manufactured clip applier jaws that are thereafter assembled together allows for the clip applier jaws to have a metallic clip guidance track to be built into the lateral inside facing portion of the clip applier jaws. The independently manufactured clip applier jaws using MIM may further comprise distal clip retention features, such as ledges, for example, which prevent the unintentional ejection of a clip from the distal end of the clip applier jaws. Such distal clip retention features can extend above the primary face of the clip applier jaws owing to these MIM processes.

As discussed above, and as described in greater detail below, certain clip appliers are configured to be inserted into a patient through a passage defined in a trocar. That said, the clip jaws of many clip appliers are wider than the trocar passage when they are in their open configuration. Described below are various systems that can be incorporated into a clip applier to facilitate the insertion of the clip applier through the trocar passage.

Referring to FIG. 69, a graph 71000 depicts the movements of a cam member and a feeder/firing member of a clip applier, such as the clip applier 70100, for example. The cam member is similar to cam member 70180 and the feeder shoe is similar to firing member 70165 illustrated in FIGS. 35A-38, for example. In order to configure the clip applier 70100 in a trocar-insertion configuration, the cam member is moved to a fully advanced position to close the jaws of the

clip applicator and the feeder shoe is moved to a fully retracted position. In various instances, the clip applicator comprises a control system including a button which, when depressed, places the clip applicator in its trocar-insertion configuration. In at least one instance, the control system operates the one or more electric motors of the clip applicator to configure the drive systems as described above. At such point, the clip applicator is ready to be inserted into the patient through the trocar. Once inserted into the patient, the button can be pressed again and, in response thereto, the control system will retract the cam member to a fully retracted position and open the jaws of the clip applicator. This button can be pressed repeatedly to toggle the configuration of the clip applicator as needed. Such an arrangement is also useful to remove the clip applicator from the patient through the trocar. The reader should appreciate that the opening and closing of the jaws via the button will not affect the other functions of the clip applicator such as advancing a clip, forming a clip, and/or ejecting a clip from the clip magazine.

Once the clip applicator has been inserted through the trocar and the button has been actuated a second time (i.e., the jaws are open), further to the above, a firing button can be pressed resulting in the feeder shoe advancing to a fully advanced position. A clip will be advanced with the feeder shoe as described above in relation to clip applicator **70100** (FIGS. **35A-38**), for instance. The feeder shoe can then be retracted to a fully retracted position and the cam member can be advanced to the fully advanced position to form the clip around tissue of the patient, as also described above. The cam member can then be retracted to the fully retracted position to release the clip and the tissue. Once all of the clips have been applied, or at least a sufficient number of clips have been applied, the button could be actuated again to close the jaws to allow the clip applicator to be removed through the trocar. Such an arrangement enables the user of the clip applicator to close the jaws without releasing a loose clip into the patient.

Further to the above, embodiments are envisioned where a clip applicator comprises a motor and a motor controller. The motor controller can be configured to control the motor via a processor and a memory. The motor controller can implement motor control algorithms to configure the jaws to open and close as well as advance a clip into the jaws. For example, a motor control algorithm can be implemented to allow the jaws to advance a clip into a crimping and/or forming position, as described above, after the jaws have been inserted through the trocar. By not feeding a clip into the jaws until after the clip applicator has been introduced into the patient, the jaws can be moved into a very compact arrangement when being inserted through the trocar as discussed above.

Turning now to FIG. **70**, a graph **71100** depicts the movements of a cam member and a feeder shoe of a clip applicator comprising a rotating clip magazine (i.e., a barrel magazine), such as the clip applicator **70600**, for example. The operation of the clip applicator depicted in FIG. **70** is similar to that of clip applicator **70600** in many respects. For example, the cam member is similar to closure tube **70620**, the feeder shoe is similar to feeder member **70630**, and the barrel magazine is similar to rotatable clip magazine **70650** illustrated in FIGS. **52-60**, for example. The clip applicator is placed into the patient through a trocar with the jaws closed and a clip positioned in the jaws and another clip aligned with the feeder shoe for deployment out of the barrel magazine. With the feeder shoe in the home position (i.e., zero displacement) the cam member can be advanced to a fully advanced position from the home position to crimp the clip already

placed within the jaws. In at least one instance, the distance between the home position and the fully advanced position is 0.3", for example. The cam member is then retracted to a partially advanced position just proximal to the fully advanced position to reduce the force applied to the clip by the jaws. The cam member is advanced again to the fully advanced position to crimp the clip again. By applying a force, reducing that force, and then applying the same, or another, force again, the elasticity within the clip can be reduced such that full plastic deformation can occur to properly crimp the clip onto the patient tissue. The partially advanced position is dependent on the type of clip being utilized with the clip applicator. For example, the partially advanced position is preferably 0.2" distal from the home position for a clip with a clip opening of 0.210" and is preferably 0.23" distal from the home position for a clip with a clip opening of 0.180", for example. Suitable thresholds can be set by the user depending on the type of clips in the barrel magazine being utilized with the clip applicator. Other embodiments are envisioned with different clip sizes and position arrangements for the partially retracted and fully advanced positions.

In any event, after the clip has been properly crimped, the cam member is then retracted proximally toward the home position as the feeder shoe distally advances a clip out of the barrel magazine toward the jaws of the clip applicator into a pre-form position when the feeder shoe is 0.08" distal from the home position, for example. When the clip is in the pre-form position, the jaws can be partially opened by retracting the cam member slightly beyond the home position, i.e., the cam member interacts with the jaws of the clip applicator to open the jaws when the cam member is retracted proximal to the home position, as discussed above. Such an arrangement allows the clip to be expanded by the pre-form features on each of the jaws (i.e., protrusions **70608**) as discussed above. The feeder shoe then distally advances the clip further into a crimping position—0.3" distal to the home position, for example. Once the feeder shoe is advanced beyond the barrel magazine (i.e., to the pre-form position) the barrel magazine can be cycled (i.e., rotated) to position another clip for advancement into the jaws. The barrel magazine is cycled by retracting the cam member to a fully retracted position—0.05" proximal to the home position, for example. The cycled clip will be biased against the feeder shoe which prevents the clip from being completely ejected from the barrel magazine. Once the feeder shoe is retracted to the home position the cycled clip can be displayed (i.e., the biasing member in the barrel magazine can now position the cycled clip into alignment with the feeder shoe because the feeder shoe has been retracted and is no longer blocking such movement). At this point a clip that has been pre-formed is positioned in the jaws and another clip is aligned with the feeder shoe for deployment out of the barrel magazine into the clip applicator jaws, just as when the clip applicator was first inserted into the patient. The same operations discussed above can be performed until all of the clips in the barrel magazine are spent.

A graph **71200** of a firing member of a clip applicator, such as any of the clip applicators described herein, for example, is illustrated in FIG. **71**. The graph **71200** shows the relationship between the force required to advance a clip within the clip applicator (i.e., via the firing member) versus displacement. With further reference to FIG. **71**, a graph **71300** of the same clip applicator is illustrated showing the relationship between the voltage applied to the motor driving the firing member of the clip applicator versus time. The motor controller of the clip applicator can monitor the current being drawn by the

motor and/or the force being applied to the firing member by the motor to detect a clip feed jam, or an irregular force within the clip applicator, and then prevent further advancement of the firing member by implementing changes to the voltage applied to electric motor, as seen in graph 71300. In other words, if the monitored force exceeds a threshold value, and/or the monitored motor current exceeds a threshold value, during the clip feed step, the motor controller can, one, reduce the magnitude of the voltage potential being applied to the motor for a period of time and, two, further assess the force within the firing system and/or further assess the electrical current being drawn by the motor. If the force and/or motor current continue to increase with the continued application of voltage to the motor, the motor control system can stop the motor and/or reverse the direction of the motor shaft to retract the firing member through a short stroke distance to clear the jammed clip. Once the jammed clip is cleared, the clip applicator can return to its normal operation and prepare the next clip to be advanced in accord with the normal operating sequence of the clip applicator.

Other embodiments are envisioned where clearing the jammed clip is accomplished by interrupting the normal sequence of the end effector jaw operations. More specifically, once the clip jam is detected the control system of the clip applicator (i.e., motor controller, processor, and memory) could request the clinician initiate a jam removal actuation. The jam removal actuation results in the jaws of the clip applicator being opened further than normal prior to another attempt to re-advance the clip. During the attempt to re-advance the clip, the acceptable load threshold, i.e., the current threshold and/or the force threshold, could be elevated above the normal thresholds previously discussed to insure the clip is ejected from the jaws. Once the jammed clip has been ejected, the clip applicator could return to its normal operation and prepare the next clip to be advanced in accord with the normal operating sequence of the clip applicator.

As mentioned above, certain clip applicators can be loaded with clips having a first size and/or a second size. The relative size of the clips can be measured using any suitable dimension, such as the leg-to-leg width of the clips, for example. First clips having a first width can be wider than second clips having a second width. In various instances, the clip applicator can be loaded with only first clips, only second clips, or both first and second clips at the same time. In any event, clips having different sizes may deform differently for a given closure stroke of the clip jaws. Thus, for instance, a first closure stroke of the clip jaws may be more preferable for the first clips while a second closure stroke of the clip jaws may be more preferable for the second clips. Many of the clip applicators disclosed herein are capable of selectively applying more than one closure stroke to the clip jaws; however, in order to apply the correct closure stroke to a clip, the clip applicator needs to be able to assess which size of clip is positioned within the clip jaws. In certain instances, such information can be manually entered into the control system of the clip applicator by the clinician. Such an arrangement is convenient when the clips in the clip applicator all have the same size. In various instances, the clip cartridge attached to the clip applicator comprises a marker, such as a microchip, for example, which can be evaluated by the control system and/or a sensor circuit in communication with the control system, for example. Such an arrangement is convenient when the clips in the clip cartridge all have the same size.

In various instances, further to the above, the clip applicator can be configured to assess the clip positioned between the clip jaws of the clip applicator to assess the size of the clip.

Once a clip is loaded between the clip jaws, the control system can partially operate the jaw closure drive and observe the force within the jaw closure drive and/or the current drawn by the electric motor of the jaw closure drive. The control system is configured to compare the measured data to data stored in a memory device, for example, to assess whether the clip between the clip jaws is a first clip or a second clip, or any other clip. For instance, if the measured force and/or motor current follows a first profile, then the control system will determine that the clip is a first clip and then apply the first closure stroke. Similarly, the control system will apply the second closure stroke if the measured force and/or motor current follows a second profile for the second clip. As such, the control system can use the jaw closure drive to apply a short evaluation closure stroke to assess the clip size and then complete the full closure stroke as appropriate. In at least one instance, the control system can reset the jaw closure drive after performing the short evaluation closure stroke and then complete a full closure stroke as appropriate. In various instances, it is envisioned that the short evaluation closure stroke does not plastically deform, or at least substantially plastically deform, the clip.

Referring to FIG. 72, a graph 71400 of the force applied to a pair of jaws of a clip applicator versus time is illustrated. The control system of the clip applicator can monitor the force within the crimping drive and/or the electric current drawn by the motor to determine the amount of force needed to crimp a clip positioned within the jaws of the clip applicator. This feedback force is initially dependent on the size and/or type of clip that is within the jaws for a first portion of the closure stroke of the jaws. Once the size/type of clip is determined, the force applied to the jaws of the clip applicator can be adjusted for the remainder of the jaw closure stroke to crimp the clip with the proper amount of force. Such an arrangement is convenient when more than one size of clip has been loaded into the clip applicator. Other embodiments are envisioned where an adaptive control program change is initiated by the cartridge identifying itself to the clip applicator upon insertion into the clip applicator. This allows the clip applicator to update to the alternative control program and thresholds (i.e., the forces applied to the jaws) for the size/type of clip loaded into the clip applicator. Further, an alternative to the identification of the cartridge could be the detection of the loads needed to accomplish the first job of the clip applicator, which could be the advancement of a clip from the cartridge or pre-forming a clip within the jaws as discussed above. The first job of the clip applicator may have a significantly higher load threshold needed to complete the operation and exceeding that threshold, or not, will then determine the subsequent operations the clip applicator and the threshold limits of each operation.

Many of the clip applicators discussed herein have been discussed in the context that the clip jaws of the clip applicators are squeezed to crush a clip into its proper size. Other embodiments are envisioned in which a clip is elastically or resiliently stretched and then released once the targeted tissue has been positioned within the stretched clip. Such an arrangement can be particularly useful when clamping or clipping blood vessels, for example. In such instances, a clip can be released to resiliently return to, or at least toward, its unstretched position and clamp the blood vessel in an atraumatic, or a nearly atraumatic, manner. All of the clip applicators disclosed herein can be adapted to apply such stretch-and-release clips. Moreover, further to the above, the clip applicators disclosed herein can be configured to apply

both the clamp-to-crush clips and the stretch-and-release clips. Similar to the above, the clip applicators would need to be able to identify the type of clips contained therein in order to apply them properly to the patient tissue. Identification chips in the clip cartridges could be used for such purposes, for example.

FIG. 75 depicts a clip applicator system 71500 in accordance with at least one embodiment. The clip applicator system 71500 comprises the clip applicator 70600 discussed above. The clip applicator system 71500 further comprises a magnet aligned with one of the clips 70654 of the rotatable clip magazine 70650. The clip applicator system 71500 further comprises a sensor, such as a Hall Effect sensor 71502, for example, fixedly positioned within the ground portion 70612 of the clip applicator 70600. The magnet can be sensed by the Hall Effect sensor 71502 and, based on the voltage potential created by the Hall Effect sensor, the control system of the clip applicator 71500 can determine the radial location and orientation of the magnet and, thus, the radial location and orientation of the clip magazine 70650. When the magnet is in a first position 71504, referring to FIG. 76, the rotatable clip magazine 70650 is loaded with a full compliment of clips 70654 and one of the clips 70654 can be advanced out of the rotatable clip magazine 70650 into the end effector 70605. The rotatable clip magazine 70650 can then be cycled (e.g., rotated) as discussed above, causing the magnet to move between the first position 71504 and a second position 71506. Another clip 70654 can be advanced out of the rotatable clip magazine 70650 and the rotatable clip magazine 70650 can be cycled again, causing the magnet to move to a third position 71508. Another clip 70654 can be advanced out of the rotatable clip magazine 70650 and the rotatable clip magazine 70650 can be cycled again, causing the magnet to move to a fourth position 71510. Further, another clip 70654 can be advanced out of the rotatable clip magazine 70650 and the rotatable clip magazine 70650 can be cycled again, causing the magnet to move to a fifth position 71512. In the fifth position 71512, the last clip 70654 in the rotatable clip magazine 70650 can be advanced out of the rotatable clip magazine 70650. Thus, the clip applicator system 71500 can determine the status of the clip magazine 70650 (i.e., the number of clips remaining) depending on the position of the magnet relative to the Hall Effect sensor 71502. Further to the above, FIG. 76 depicts the voltage potential generated by the Hall Effect sensor 71502 depending on the position of the magnet.

In at least one alternative embodiment of the clip applicator system 71500, the clip magazine 70650 further comprises an extension member, or bar, that extends proximally from the clip magazine 70650 once all of the clips 70654 have been ejected from the clip magazine 70650. The extension member is sensed by the Hall Effect sensor 71502 and/or another electrical sensor within the clip applicator 70600. When the extension member is detected by the clip applicator system 71500, the mechanical systems (i.e., the feeder member 70630, firing member 70640, and drive tube 70620) of the clip applicator 70600 can be locked out to prevent further actuation.

FIG. 77 depicts a clip applicator 71600. The clip applicator 71600 comprises a first jaw 71610a and a second jaw 71610b moveable relative to each other between open and closed positions. The clip applicator 71600 is configured to receive a clip 71604 which is crimped by the first jaw 71610a and the second jaw 71610b when the first jaw 71610a and the second jaw 71610b are moved toward the closed position. The clip applicator 71600 comprises a resistive sensing circuit configured to determine the position of the

clip 71604 within the clip applicator 71600. The resistive sensing circuit comprises a supply voltage source 71602 which supplies current through a first lead 71620a, the first jaw 71610a, the clip 71604, the second jaw 71610b, and a Resistor 71620b and back to a return 71606 where the current can be measured. When the clip 71604 is moved distally through the clip applicator, such as to the position shown by clip 71604', for example, the path through which the current flows is larger (i.e., larger than the path for clip 71604) and the resistance within the path is greater and, as a result, the current measured at the return 71606 will be smaller. Thus, the current measured at the return 71606 is directly proportional to the position of the clip 71604 within the clip applicator 71600. The control system of the clip applicator is configured to use the magnitude of the current in this sensing circuit to assess the position of the clip 71604' within the jaws 71610a and 71610b. Higher current magnitudes indicate that the clip 71604' is more proximal and lower current magnitudes indicate that the clip 71604' is more distal, while intermediate current magnitudes indicate that the clip 71604' is positioned in the middle of the jaws 71610a and 71610b.

Referring still to FIG. 77, the clip applicator 71600 further comprises a second resistive sensing circuit configured to determine when the first jaw 71610a and the second jaw 71610b are in the closed position. More specifically, the supply voltage supplies current which flows through a first lead 71630a connected to the first jaw 71610a. The first lead 71630a is insulated from the first jaw 71610a, i.e., it does not allow current to flow into the first jaw 71610a. When the first jaw 71610a and the second jaw 71610b are in the closed position, the first lead 71630a contacts a second lead 71630b connected to the second jaw 71610b which allows current to flow into a resistor 71630c and into the return 71606 where the current can be measured. The second lead 71630b is also insulated from the second jaw 71610b. Thus, when the first jaw 71610a and the second jaw 71610b are in the closed position, the control system, via the return, will sense a current determined by a second resistance through the resistor 71630c which indicates that the first and second jaws 71610a, 71610b are in the closed position. The control system may, at the same time, also sense the resistance through resistor 71620b which indicates the position of the clip 71604 within the clip applicator 71600. Other embodiments are envisioned where only one of the resistive sensing circuits discussed above are utilized with the clip applicator 71600.

FIGS. 78A and 78B depict a variable resistance system for use with a clip applicator 71650 configured to gather information (i.e., data) on the position of the clip jaws and the formation of the clip during a crimping stroke. The clip applicator 71650 is similar to clip applicator 71600, for example, in many respects. The clip applicator 71650 comprises a first jaw 71650a and a second jaw 71650b moveable relative to each other between an open position (FIG. 78A), a partially closed position (FIG. 78B) and a closed position. The clip applicator 71650 is configured to receive a clip 71654 which is crimped by the first and second jaws 71650a, 71650b when the first and second jaws 71650a, 71650b are moved toward the closed position. The legs of the clip 71654 positioned within the first and second jaws 71650a, 71650b extend outwardly into engagement with the first and second jaws 71650a, 71650b to ensure the clip 71654 is properly seated therebetween (i.e., so there is no slop or play between the clip 71654 and the first and second jaws 71650a, 71650b). In various instances, the legs of the clip are slightly deflected inwardly when the clip is fed into the first and second jaws

71650a, 71650b. The variable resistance system of the clip applier **71650** is described in further detail below.

The variable resistance system comprises three return paths through which an electrical current can flow and be sensed by the control system of the clip applier in order to determine the position of the first and second jaws **71650a, 71650b** relative to each other, and to sense the formation of the clip **71654**. The first return path **71660** comprises the second jaw **71650b**. The second return path **71670** comprises a variable resistor configured to determine the position of the first jaw **71650a** and the second jaw **71650b** relative to each other. More specifically, as the first jaw **71650a** and the second jaw **71650b** are moved from the open position (FIG. **78A**) toward the closed position the resistance in the variable resistor will change. The third return path **71680** comprises another variable resistor at the distal end of the second jaw **71650b** which is insulated from the second jaw **71650b**. When the first jaw **71650a** and the second jaw **71650b** are in the open position (FIG. **78A**), the clip **71654** is in contact with the first return path **71660** and the third return path **71680**. When the first jaw **71650a** and the second jaw **71650b** are in the partially closed position (FIG. **78B**), the clip **71654** is only in contact with the first return path **71660**. When the first jaw **71650a** and the second jaw **71650b** are in the closed position the clip **71654** has been fully crimped and is once again in contact with the first return path **71660** and the third path **71680**. Throughout the movement of the first jaw **71650a** and the second jaw **71650b** between the open position, the partially closed position, and the closed position, the second return path **71670** determines the position of the first jaw **71650a** relative to the second jaw **71650b**. Thus, the variable resistance system can determine jaw position and sense clip formation throughout the clip formation process by determining the resistance through each of the three paths.

FIG. **79** depicts a clip applier jaw **71700** in accordance with at least one embodiment. The clip applier jaw **71700** is configured to move toward and away from another clip applier jaw and is further configured to crimp a clip as discussed above in relation to various embodiments disclosed herein. The clip applier comprises a proximal strain gauge **71720** and a distal strain gauge **71730**, and/or any number of suitable strain gauges. The proximal strain gauge **71720** and the distal strain gauge **71730** are positioned on a face **71710** of the clip applier jaw **71700**. Other embodiments are envisioned with more than two strain gauges spaced along any suitable face of the clip applier jaw **71700** and/or built into the clip applier jaw **71710** itself. The proximal strain gauge **71720** is part of a proximal strain gauge circuit and generates a voltage signal indicative of the strain within the clip applier jaw **71700** in a first location and the distal strain gauge **71730** is part of a distal strain gauge circuit and generates a voltage signal indicative of the strain within the clip applier jaw **71700** in a second location. The proximal and distal strain gauge circuits are in communication with the control system of the clip applier and, as a clip is formed between the clip applier jaw **71700** and another clip applier jaw, different levels of strain will be detected by the control system at the first location and the second location.

Referring to FIG. **80**, a graph **71800** of the strain (measured in Volts, but could be more conveniently illustrated in mV) within the proximal strain gauge **71720** and the distal strain gauge **71730** at various stages of clip formation is depicted. Upon the initial placement of a clip between the clip applier jaws, the clip legs of certain clips are biased outwardly into engagement with the jaws, as discussed

above. In such instances, a larger strain may be measured in the proximal strain gauge **71720** as compared to the distal strain gauge **71730**. The difference in the voltages within the strain gauges **71720, 71730** at this stage is voltage **A** as depicted in FIG. **80**. As the jaws of the clip applier begin to form the clip, the reading from the proximal strain gauge **71720** will exceed a pre-formed strain threshold T_{PF} while the reading from the distal strain gauge **71730** remains below the pre-formed strain threshold T_{PF} . This can indicate that the clip has only been formed at or near the proximal strain gauge **71720**. The difference in the voltages between the readings of the strain gauges **71720, 71730**, at this stage, is measured to be **A'**. As the jaws of the clip applier form the clip further, the reading from the distal strain gauge **71730** will eventually exceed the pre-formed strain threshold T_{PF} and the reading from the proximal strain gauge **71720** will eventually exceed a full-formed strain threshold T_{FF} . This can indicate that the clip has been fully formed at or near the proximal strain gauge **71720** and has begun to be deformed at or near the distal strain gauge **71730**. When the readings from the proximal strain gauge **71720** and the distal strain gauge **71730** are both measured to be beyond the full-formed threshold T_{FF} and the pre-formed threshold T_{PF} , respectively, the difference in the strain gauge readings is measured as **A''** as depicted in FIG. **80**. Further, as the jaws of the clip applier form the clip further, the reading from the distal strain gauge **71730** will eventually exceed the full-formed strain threshold T_{FF} and the reading from the proximal strain gauge **71720** will continue to increase above the full-formed strain threshold T_{FF} . When the reading from the proximal strain gauge **71720** and the distal strain gauge **71730** are measured to both be beyond the full-formed threshold T_{FF} , the difference in the strain gauge readings is measured as **A'''** as depicted in FIG. **80**.

Further to the above, the state of the clip can be determined by measuring the differences between the readings of the proximal strain gauge **71720** and the distal strain gauge **71730** throughout the formation of a clip. More specifically, a difference in voltage measuring **A** indicates that the clip has yet to be deformed. A difference in voltage measuring **A'** indicates that only a proximal portion of the clip has been deformed. A difference in voltage measuring **A''** indicates that the proximal portion of the clip has been fully formed and the distal portion of the clip has begun to be deformed. And lastly, a difference in the voltage measuring **A'''** indicates that both the proximal and distal portions of the clip have been fully formed.

As discussed above, a clip applier is often inserted into a patient through a trocar. As a result, the diameter of the passageway through the trocar dictates a lot of the design considerations of the clip applier—especially of the portions of the clip applier that are inserted through and/or into the trocar passageway. That said, there is often motivation to make trocars as narrow as possible to reduce the size of the incisions in the patient, among other reasons. As such, narrow trocars, and narrow trocar passageways, present significant design constraints and often limit the widths of the clips that can be used. With this in mind, clip appliers are disclosed herein which are configured to store the clips in a small configuration and then enlarge the clips once they are on the other side of the trocar. Such an arrangement can allow clips to be used which, in their enlarged state, exceed the diameter of the trocar that they were inserted through.

FIGS. **81A** and **81B** depict a clip applier **71900** in accordance with at least one embodiment. The clip applier **71900** comprises a first jaw **71910a** and a second jaw **71910b** moveable relative to each other about a pivot pin

71912 between a closed position, a home position (FIG. 81A), and an open position (FIG. 81B). The clip applicator 71900 further comprises a cam member 71920 configured to move the first jaw 71910a and the second jaw 71910b between the closed position, the home position, and the open position. More specifically, the first jaw 71910a and the second jaw 71910b are moved to the open position by the cam member 71920 when the cam member 71920 is moved to a fully retracted position (FIG. 81B) due to the cam member 71920 engaging a first jaw cam 71914a on the first jaw 71910a and a second jaw cam 71914b on the second jaw 71910b. Furthermore, the first jaw 71910a and the second jaw 71910b are moved to the home position by the cam member 71920 when the cam member 71920 is moved distally to a home position depicted in FIG. 81A (i.e., the cam member 71920 is no longer engaging the first jaw cam 71914a and the second jaw cam 71914b allowing the first jaw 71910a and the second jaw 71910b to assume the home position). Further still, the first jaw 71910a and the second jaw 71910b are moved to the closed position by the cam member 71920 when the cam member 71920 is moved distally to a fully advanced position due to the cam member 71920 cammingly engaging the outer surfaces of the first jaw 71910a and the second jaw 71910b. The first jaw 71910a and the second jaw 71910b are configured to receive a clip 71904 therein to be expanded during a pre-form operation and crimped during a crimping operation. FIG. 81A depicts the clip 71904 in a storage configuration when the first jaw 71910a and the second jaw 71910b are in the home position. The clip 71904 can be a 5 mm clip in the storage configuration, for example. Expansion of the clip 71904 during the pre-form operation and crimping of the clip 71904 during the crimping operation are described in further detail below.

The first jaw 71910a and the second jaw 71910b comprise pre-forming features, or protrusions 71930a and 71930b, similar to protrusions 70126a and 70126b discussed above. The protrusions 71930a and 71930b engage the inner surfaces of the clip 71904 and expand the clip 71904 from the storage configuration (FIG. 81A) to a firing configuration (FIG. 81B) when the first jaw 71910a and the second jaw 71910b are moved to the open position. For example, the clip 71904 is expanded from the storage configuration where the clip 71904 has an approximately 5 mm width to a firing configuration where the clip 71904 has an approximately 10 mm width. That said, a clip can have any suitable stored width and any suitable expanded width. After the clip 71904 has been expanded to the firing configuration, a firing member advances the clip over the protrusions 71930a, 71930b into a crimping position within the first jaw 71910a and the second jaw 71910b. The protrusions 71930a and 71930b comprise angled portions which allow the clip 71904 to slide over the protrusions 71930a and 71930b when advanced by the firing member. Once a clip is in the crimping position, the cam member 71920 is advanced distally to the fully advanced position during a crimping stroke to move the first jaw 71910a and the second jaw 71910b to the closed position, and, thus, crimp the clip 71904 within the crimping chamber.

Further to the above, the clip applicator 71900 further comprises a sensor array 71940 that detects a magnet 71950 included in one of the first jaw 71910a and the second jaw 71910b. The sensor array 71940 detects the location of the magnet 71950 relative to the sensor array 71940 in order to determine the position of the first jaw 71910a and the second jaw 71910b relative to each other during the operation of the clip applicator 71900.

As discussed herein, clip applicators are loaded with clips in a variety of manners. For instance, clips can be loaded into a clip applicator by way of a clip cartridge. Such clip cartridges can comprise clips stacked along a longitudinal axis, for example. Such clip cartridges can also comprise clips stacked along an axis which is transverse to the longitudinal axis of the clip applicator. Certain cartridges are stored in a circumferential configuration, as described above. That being said, some clip applicators may be configured to hold only one clip at a time. The teachings provided herein are adaptable to such clip applicators. In at least one instance, a one-clip clip applicator, for example, can be used with a docking station comprising a plurality of clips stored therein. In such instances, the clinician can use the docking station to re-supply a clip to the one-clip clip applicator after each use of the clip applicator. In certain instances, the docking station can be positioned in the patient which prevents the need to remove the clip applicator from the patient such that the clip applicator can be reloaded. In at least one instance, as discussed below, the docking station can be attached to a trocar inserted into the patient, for example. The above being said, the idea of a docking station positioned within a patient can also be used with a multi-clip clip applicator. In such instances, one or more clips from the docking station can be loaded into the multi-clip clip applicator without having to remove the clip applicator from the patient.

Turning to FIGS. 82 and 83, a clip applicator system 72000 is depicted. The clip applicator system comprises a trocar 72010, a clip magazine 72050, and a clip applicator 72020. The clip applicator 72020 comprises an elongate shaft 72011 extending from a housing, an articulation joint 72022 extending from the elongate shaft 72011, and an end effector 72024 extending from the articulation joint 72022. The end effector 72024 comprises a first jaw 72024a and a second jaw 72024b moveable relative to each other between an open position and a closed position. The end effector 72024 is articulable relative to the elongate shaft 72011 about the articulation joint 72022. The clip magazine 72050 comprises an opening 72051 (see FIG. 82) through the clip magazine 72050. Prior to insertion of the clip applicator 72020 through the trocar 72010, the clip magazine 72050 is positioned within the patient and attached to the distal end of the trocar 72010. The opening 72051 allows the clip magazine 72050 to be received and attached to the distal end of the trocar 72010 as depicted in FIG. 83. The clip magazine 72050 can be threadably attached to the distal end of the trocar 72010, for example. The clip applicator 72020 is then inserted through the trocar 72010 and the opening 72051 of the clip magazine 72050 until the end effector 72024 of the clip applicator 72020 is positioned distal to the clip magazine 72050. As the clip applicator 72020 is retracted toward the clip magazine 72050, the clip applicator 72020 engages the clip magazine 72050 to eject a clip from the clip magazine 72050 into the end effector of the clip applicator 72020, as discussed in greater detail below.

Turning to FIGS. 85A and 85B, the clip magazine 72050 further comprises, a leaf spring 72052, a plurality of clips 72054 removably stored in the clip magazine 72050, a spring 72059, a sled 72058, and a loading arm 72056. The leaf spring 72052 prevents the clips 72054 from falling out of the clip magazine 72050 inadvertently. The spring 72059 biases the sled 72058 distally to bias the clips 72054 toward the loading arm 72056. The loading arm 72056 grasps and holds a clip 72054 in place until acted upon by the clip applicator 72020. To this end, the loading arm 72056 engages a jaw wing 72026 of the clip applicator 72020 as the clip applicator 72020 is retracted towards the clip magazine 72050 (i.e.,

proximally). When the jaw wing 72026 is engaged by the loading arm 72056, the jaw wing 72026 moves proximally and the loading arm 72056 rotates toward the end effector 72024 to load a clip 72054 from the clip magazine 72050 into the end effector 72024 of the clip applier 72020. FIGS. 84A-84C depict the movements of the jaw wing 72024 and the loading arm 72056 as the clip applier 72020 is retracted towards the clip magazine 72050. After a clip 72054 has been loaded into the end effector 72024, the clip applier 72024 can be moved distally to a desired location within the patient to crimp the clip 72054 around patient tissue. After the clip 72054 is crimped and released, the clip applier 72020 can be retracted toward the clip magazine 72050 (i.e., proximally) to engage the jaw wing 72026 with the loading arm 72056 of the clip magazine 72050 to load another clip into the clip applier 72020. This process can be repeated until all of the clips 72054 have been depleted from the clip magazine 72050, and/or until a suitable number of clips have been applied.

Turning now to FIGS. 86A and 86B, the relationship between the jaw wing 72026 and the first and second jaws 72024a and 72024b of the clip applier 72020 is depicted. The jaw wing 72026 is operably engaged with the first and second jaws 72024a and 72024b such that, when the first and second jaws 72024a and 72024b are in the closed position (FIG. 86B), the jaw wing 72026 is retracted. To this end, the clip applier 72020 can be inserted through the clip magazine 72050 without the jaw wing 72026 engaging the loading arm 72056 of the clip magazine 72050. Other embodiments are envisioned where the clip applier 72020 engages the clip magazine 72050 to load a clip 72054 into the end effector 72024 when the clip applier 72020 is moved from a proximal position behind the clip magazine 72050 to a distal position beyond the clip magazine 72050.

A clip applier 73000 is depicted in FIGS. 87A-87D. The clip applier 73000 comprises an elongate shaft 73010 extending from a housing, an articulation joint 73020 extending from the elongate shaft 73010, a magazine housing 73030 extending from the articulation joint 73020, and an end effector 73040 extending from the magazine housing 73030. The end effector 73040 comprises a first jaw 73040a and a second jaw 73040b moveable relative to each other between an open position and a closed position. The magazine housing 73030 comprises a bottom housing 73030b and a top housing 73030a. The top housing 73030a is moveable relative to the bottom housing 73030b between an open position (FIG. 87A) and a closed position (FIG. 87C) about a pivot pin 73032 attached to the articulation joint 73020. The magazine housing 73030 can receive a clip magazine 73050 comprising a plurality of clips 73054 stored therein. The clips 73054 are loaded into the clip magazine 73030 and are locked in place by a biasing member, or leaf spring 73056. The leaf spring 73056 prevents the clips 73054 from being ejected from the clip magazine 73050 until the clip magazine 73050 is seated in the magazine housing 73030, as discussed in greater detail below.

The clip magazine 73050 further comprises notches 73058 on either side of the clip magazine 73050. To properly seat the clip magazine 73050 in the magazine housing 73030, the notches 73058 of the clip magazine 73050 are aligned with protrusions 73034 of the magazine housing 73030 to seat and align the clip magazine 73050 in the magazine housing 73030 as depicted in FIG. 87B. Once the clip magazine 73050 is installed into the magazine housing 73030, the top housing 73030a can be moved to the closed position as depicted in FIG. 87C. The top housing 73030a comprises a lockout release, or protrusion 73032, that

engages the leaf spring 73056 of the clip magazine 73050 when the clip magazine 73050 is installed in the magazine housing 73030 and the top housing 73030a is in the closed position as depicted in FIG. 87D. When the leaf spring 73056 is depressed by the protrusion 73032, the clips 73054 are no longer locked into position within the clip magazine 73050 and can be ejected from the clip magazine 73050 into the end effector 73040 by a firing member.

Turning now to FIGS. 88A-88D, after all of the clips 73054 have been ejected from the clip magazine 73050, the clip magazine 73050 can be locked out when removed from the magazine housing 73030 to prevent the clip magazine 73050 from being re-installed into the magazine housing 73030 until reloaded with at least one new clip 73054. More specifically, the clip magazine 73030 comprises a sled 73052 that moves through the clip magazine 73030 as the clips 73054 are ejected. The sled 73052 comprises spring loaded detents 73059 which align with the notches 73058 in the clip magazine 73050 when the last clip 73054 has been ejected from the clip magazine 73050. When the clip magazine 73050 is installed in the magazine housing 73030 and the clip magazine 73050 has been spent, the spring loaded detents 73059 are biased against the protrusions 73034 as depicted in FIGS. 88B and 88D. After the clip magazine 73050 is removed from the magazine housing 73030, the spring loaded detents 73059 protrude through the notches 73058 to lock the sled 73052 into place as depicted in FIG. 88A. The spent clip magazine 73050 cannot be re-installed into the magazine housing 73030 unless at least one clip 73054 is loaded into the clip magazine 73050. More specifically, until the sled 73052 is retracted to disengage the spring loaded detents 73059 from the notches 73058 (i.e., at least one clip 73054 is installed) the clip magazine 73050 cannot be installed into the magazine housing 73030 because the spring loaded detents 73059 occupy the notches 73058 and will not allow the notches 73058 to properly align and seat with the protrusions 73034 of the magazine housing 73030.

Other embodiments are envisioned where a clip applier system comprises a clip applier, a trocar, and a sensing system. The clip applier of the clip applier system is similar to clip applier 72020 in many respects and the trocar is similar to the trocar 72010 in many respects. The trocar can comprise a sensor, such as a Hall Effect sensor, for example, attached to, or near, the distal end of the trocar. The clip applier further comprises a detectable element, such as a magnet, for example, positioned in the end effector of the clip applier. The magnet in the end effector of the clip applier and the Hall Effect sensor on the distal end of the trocar are included in the sensing system. The sensing system is in signal communication with the control system of the clip applier via a wireless signal transmitter in the trocar and a wireless signal receiver in the clip applier. The control system of the clip applier is configured to automatically control the opening and closing of the jaws of the end effector depending on the position of the magnet relative to the Hall Effect sensor. More specifically, when the magnet in the jaws is positioned a predetermined distance distal to the Hall Effect sensor of the trocar—which indicates that the jaws have passed through the trocar, the clip jaws are automatically moved to an open position by the control system of the clip applier. Moreover, the control system of the clip applier can also automatically load a clip into the open jaws. Such an arrangement reduces the time needed to load the clip applier after being inserted into a patient. Further, when the magnet in the jaws is approaching the Hall Effect sensor of the trocar from a distal position (i.e., the clip

applier is being retracted proximally toward the trocar) the control system automatically moves the jaws to a closed position to allow the clip applier to be retracted through the trocar.

FIG. 89 is a logic diagram of a control system 75000 for use with any of the various clip appliers described herein. The control system 75000 comprises a control circuit. The control circuit includes a microcontroller 75040 comprising a processor 75020 and a memory 75030. One or more sensors, such as sensor 75080, sensor 75090, sensor 71502, and sensor array 71940, for example, provide real time feedback to the processor 75020. The control system 75000 further comprises a motor driver 75050 configured to control an electric motor 75010 and a tracking system 75060 configured to determine the position of one or more longitudinally movable components in the clip applier, such as firing member 70165 (FIG. 35A), crimping drive 70180 (FIG. 36), feeder member 70630 (FIG. 53), firing member 70640 (FIG. 53), and closure tube 70620 (FIG. 53), for example. The tracking system 75060 is also configured to determine the position of one or more rotational components in the clip applier, such as the rotatable clip magazine 70650 (FIG. 52), for example. The tracking system 75060 provides position information to the processor 75020, which can be programmed or configured to, among other things, determine the position of the rotatable clip magazine 70650 (FIG. 52), determine the position of the firing member, feeder member, closure tube and/or crimping drive, as well as determine the orientation of the jaws of the clip applier. The motor driver 75050 may be an A3941 available from Allegro Microsystems, Inc., for example; however, other motor drivers may be readily substituted for use in the tracking system 75060. A detailed description of an absolute positioning system is described in U.S. Patent Application Publication No. 2017/0296213, entitled SYSTEMS AND METHODS FOR CONTROLLING A SURGICAL STAPLING AND CUTTING INSTRUMENT, the entire disclosure of which is hereby incorporated herein by reference.

The microcontroller 75040 may be any single core or multicore processor such as those known under the trade name ARM Cortex by Texas Instruments, for example. In at least one instance, the microcontroller 75040 is a LM4F230H5QR ARM Cortex-M4F Processor Core, available from Texas Instruments, for example, comprising on-chip memory of 256 KB single-cycle flash memory, or other non-volatile memory, up to 40 MHz, a prefetch buffer to improve performance above 40 MHz, a 32 KB single-cycle serial random access memory (SRAM), internal read-only memory (ROM) loaded with StellarisWare® software, 2 KB electrically erasable programmable read-only memory (EEPROM), one or more pulse width modulation (PWM) modules and/or frequency modulation (FM) modules, one or more quadrature encoder inputs (QEI) analog, one or more 12-bit Analog-to-Digital Converters (ADC) with 12 analog input channels, for example, details of which are available from the product datasheet.

In various instances, the microcontroller 75040 comprises a safety controller comprising two controller-based families such as TMS570 and RM4x known under the trade name Hercules ARM Cortex R4, also by Texas Instruments. The safety controller may be configured specifically for IEC 61508 and ISO 26262 safety critical applications, among others, to provide advanced integrated safety features while delivering scalable performance, connectivity, and memory options.

The microcontroller 75040 is programmed to perform various functions such as precisely controlling the speed

and/or position of the firing member, feeder member, crimping drive or closure tube of any of the clip appliers disclosed herein, for example. The microcontroller 75040 is also programmed to precisely control the rotational speed and position of the end effector of the clip applier and the articulation speed and position of the end effector of the clip applier. In various instances, the microcontroller 75040 computes a response in the software of the microcontroller 75040. The computed response is compared to a measured response of the actual system to obtain an “observed” response, which is used for actual feedback decisions. The observed response is a favorable, tuned, value that balances the smooth, continuous nature of the simulated response with the measured response, which can detect outside influences on the system.

The motor 75010 is controlled by the motor driver 75050. In various forms, the motor 75010 is a DC brushed driving motor having a maximum rotational speed of approximately 25,000 RPM, for example. In other arrangements, the motor 75010 includes a brushless motor, a cordless motor, a synchronous motor, a stepper motor, or any other suitable electric motor. The motor driver 75050 may comprise an H-bridge driver comprising field-effect transistors (FETs), for example. The motor driver 75050 may be an A3941 available from Allegro Microsystems, Inc., for example. The A3941 motor driver 75050 is a full-bridge controller for use with external N-channel power metal oxide semiconductor field effect transistors (MOSFETs) specifically designed for inductive loads, such as brush DC motors. In various instances, the motor driver 75050 comprises a unique charge pump regulator provides full (>10 V) gate drive for battery voltages down to 7 V and allows the A3941 motor driver 75050 to operate with a reduced gate drive, down to 5.5 V. A bootstrap capacitor may be employed to provide the above-battery supply voltage required for N-channel MOSFETs. An internal charge pump for the high-side drive allows DC (100% duty cycle) operation. The full bridge can be driven in fast or slow decay modes using diode or synchronous rectification. In the slow decay mode, current recirculation can be through the high-side or the low-side FETs. The power FETs are protected from shoot-through by resistor adjustable dead time. Integrated diagnostics provide indication of undervoltage, overtemperature, and power bridge faults, and can be configured to protect the power MOSFETs under most short circuit conditions. Other motor drivers may be readily substituted.

The tracking system 75060 comprises a controlled motor drive circuit arrangement comprising one or more position sensors, such as the sensor 75080, sensor 75090, sensor 71502, and sensory array 71940, for example. The position sensors for an absolute positioning system provide a unique position signal corresponding to the location of a displacement member. As used herein, the term displacement member is used generically to refer to any movable member of any of the clip appliers disclosed herein. In various instances, the displacement member may be coupled to any position sensor suitable for measuring linear displacement or rotational displacement. Linear displacement sensors may include contact or non-contact displacement sensors. The displacement sensors may comprise linear variable differential transformers (LVDT), differential variable reluctance transducers (DVRT), a slide potentiometer, a magnetic sensing system comprising a movable magnet and a series of linearly arranged Hall Effect sensors similar to the arrangement illustrated in FIG. 75, a magnetic sensing system comprising a fixed magnet and a series of movable linearly arranged Hall Effect sensors similar to the arrangement

illustrated in FIGS. 81A and 81B, an optical sensing system comprising a movable light source and a series of linearly arranged photo diodes or photo detectors, or an optical sensing system comprising a fixed light source and a series of movable linearly arranged photo diodes or photo detectors, or any combination thereof.

The position sensors 75080, 75090, 71502, and 71940 for example, may comprise any number of magnetic sensing elements, such as, for example, magnetic sensors classified according to whether they measure the total magnetic field or the vector components of the magnetic field. The techniques used to produce both types of magnetic sensors encompass many aspects of physics and electronics. The technologies used for magnetic field sensing include search coil, fluxgate, optically pumped, nuclear precession, SQUID, Hall-Effect, anisotropic magnetoresistance, giant magnetoresistance, magnetic tunnel junctions, giant magnetoimpedance, magnetostrictive/piezoelectric composites, magnetodiode, magnetotransistor, fiber optic, magneto optic, and microelectromechanical systems-based magnetic sensors, among others.

In various instances, one or more of the position sensors of the tracking system 75060 comprise a magnetic rotary absolute positioning system. Such position sensors may be implemented as an AS5055EQFT single-chip magnetic rotary position sensor available from Austria Microsystems, AG and can be interfaced with the controller 75040 to provide an absolute positioning system. In certain instances, a position sensor comprises a low-voltage and low-power component and includes four Hall-Effect elements in an area of the position sensor that is located adjacent a magnet. A high resolution ADC and a smart power management controller are also provided on the chip. A CORDIC processor (for Coordinate Rotation Digital Computer), also known as the digit-by-digit method and Volder's algorithm, is provided to implement a simple and efficient algorithm to calculate hyperbolic and trigonometric functions that require only addition, subtraction, bitshift, and table lookup operations. The angle position, alarm bits, and magnetic field information are transmitted over a standard serial communication interface such as an SPI interface to the controller 75040. The position sensors can provide 12 or 14 bits of resolution, for example. The position sensors can be an AS5055 chip provided in a small QFN 16-pin 4x4x0.85 mm package, for example.

The tracking system 75060 may comprise and/or be programmed to implement a feedback controller, such as a PID, state feedback, and adaptive controller. A power source converts the signal from the feedback controller into a physical input to the system, in this case voltage. Other examples include pulse width modulation (PWM) and/or frequency modulation (FM) of the voltage, current, and force. Other sensor(s) may be provided to measure physical parameters of the physical system in addition to position. In various instances, the other sensor(s) can include sensor arrangements such as those described in U.S. Pat. No. 9,345,481, entitled STAPLE CARTRIDGE TISSUE THICKNESS SENSOR SYSTEM, which is hereby incorporated herein by reference in its entirety; U.S. Patent Application Publication No. 2014/0263552, entitled STAPLE CARTRIDGE TISSUE THICKNESS SENSOR SYSTEM, which is hereby incorporated herein by reference in its entirety; and U.S. patent application Ser. No. 15/628,175, entitled TECHNIQUES FOR ADAPTIVE CONTROL OF MOTOR VELOCITY OF A SURGICAL STAPLING AND CUTTING INSTRUMENT, which is hereby incorporated herein by reference in its entirety. In a digital signal

processing system, absolute positioning system is coupled to a digital data acquisition system where the output of the absolute positioning system will have finite resolution and sampling frequency. The absolute positioning system may comprise a compare and combine circuit to combine a computed response with a measured response using algorithms such as weighted average and theoretical control loop that drives the computed response towards the measured response. The computed response of the physical system takes into account properties like mass, inertial, viscous friction, inductance resistance, etc., to predict what the states and outputs of the physical system will be by knowing the input.

The absolute positioning system provides an absolute position of the displacement member upon power up of the instrument without retracting or advancing the displacement member to a reset (zero or home) position as may be required with conventional rotary encoders that merely count the number of steps forwards or backwards that the motor 75010 has taken to infer the position of a device actuator, a firing member, a feeder drive, a crimping drive, a closure tube, and the like.

A sensor 75080 comprising a strain gauge or a micro-strain gauge, for example, is configured to measure one or more parameters of the end effector of the clip applicator, such as, for example, the strain experienced by the jaws during a crimping operation. In one embodiment, the sensor 75080 can comprise the strain gauges 71720 and 71730 (FIG. 79) discussed in greater detail above, for example. The measured strain is converted to a digital signal and provided to the processor 75020. In addition to or in lieu of the sensor 75080, a sensor 75090 comprising a load sensor, for example, can measure the closure force applied by the closure drive system to the jaws of the clip applicator. In various instances, a current sensor 75070 can be employed to measure the current drawn by the motor 75010. The force required to clamp the first and second jaws to crimp a clip can correspond to the current drawn by the motor 75010, for example. The measured force is converted to a digital signal and provided to the processor 75020. A magnetic field sensor can be employed to measure the thickness of the captured tissue. The measurement of the magnetic field sensor can also be converted to a digital signal and provided to the processor 75020.

The measurements of the tissue compression, the tissue thickness, and/or the force required to close the end effector and crimp a clip around tissue as measured by the sensors can be used by the controller 75040 to characterize the position and/or speed of the movable member being tracked. In at least one instance, the memory 75030 may store a technique, an equation, and/or a look-up table which can be employed by the controller 75040 in the assessment. In various instances, the controller 75040 can provide the user of the clip applicator with a choice as to the manner in which the clip applicator should be operated. To this end, a display 75044 can display a variety of operating conditions of the clip applicator and can include touch screen functionality for data input. Moreover, information displayed on the display 75044 may be overlaid with images acquired via the imaging modules of one or more endoscopes and/or one or more additional surgical instruments used during the surgical procedure.

As discussed above, the clip applicators disclosed herein may comprise control systems. Each of the control systems can comprise a circuit board having one or more processors and/or memory devices. Among other things, the control systems are configured to store sensor data, for example.

They are also configured to store data which identifies the type of clip applicator attached to a handle or housing, such as handle 700 (FIG. 29), for example. More specifically, the type of clip applicator can be identified when attached to the handle or housing by the sensors and the sensor data can be stored in the control system. Moreover, they are also configured to store data including whether or not the clip applicator has been previously used and/or how many clips have been ejected from the clip magazine or clip cartridge of the clip applicator during operation. This information can be obtained by the control system to assess whether or not the clip applicator is suitable for use and/or has been used less than a predetermined number of times, for example.

The surgical instrument systems described herein are motivated by an electric motor; however, the surgical instrument systems described herein can be motivated in any suitable manner. In certain instances, the motors disclosed herein may comprise a portion or portions of a robotically controlled system. U.S. patent application Ser. No. 13/118,241, entitled SURGICAL STAPLING INSTRUMENTS WITH ROTATABLE STAPLE DEPLOYMENT ARRANGEMENTS, now U.S. Pat. No. 9,072,535, for example, discloses several examples of a robotic surgical instrument system in greater detail, the entire disclosure of which is incorporated by reference herein.

EXAMPLES

Example 1—A surgical device for clipping tissue comprising a housing comprising a motor, a shaft extending from the housing, an end effector extending from the shaft, and a first clip magazine releasably attached to the surgical device. The first clip magazine comprises a plurality of first clips and is replaceable with a second clip magazine comprising a plurality of second clips. The surgical device further comprises a firing drive operably responsive to the motor. The firing drive is configured to move a first clip from the first clip magazine into the end effector when the first clip magazine is attached to the surgical device. The firing drive is further configured to move a second clip from the second clip magazine into the end effector when the second clip magazine is attached to the surgical device. The surgical device further comprises a crimping drive operably responsive to the motor. The crimping drive is configured to crimp the first clip positioned in the end effector during a first crimping stroke when the first clip magazine is attached to the surgical device. The crimping drive is further configured to crimp the second clip positioned in the end effector during a second crimping stroke when the second clip magazine is attached to the surgical device. The surgical device further comprises a strain gauge configured to measure the strain within the end effector during the first crimping stroke. The surgical device further comprises a motor controller in signal communication with the motor and the strain gauge. The motor controller is configured to modify the second crimping stroke based on the measured strain in the end effector during the first crimping stroke.

Example 2—The surgical device of Example 1, wherein the housing comprises a handle.

Example 3—The surgical device of Example 1, wherein the housing is couplable to a robotic system.

Example 4—The surgical device of Examples 1, 2, or 3, further comprising the second clip magazine.

Example 5—A surgical device for clipping tissue comprising a housing comprising a motor, a shaft extending from the housing, an end effector extending from the shaft, and a first clip magazine comprising a first plurality of clips. The

first clip magazine is replaceable with a second clip magazine comprising a second plurality of clips. The surgical device further comprises a firing drive configured to move a first clip from the first clip magazine into the end effector when the first clip magazine is attached to the surgical device. The firing drive is further configured to move a second clip from the second clip magazine into the end effector when the second clip magazine is attached to the surgical device. The surgical device further comprises a crimping drive configured to perform a first crimping stroke when the first clip magazine is attached to the surgical device. The crimping drive is further configured to perform a second crimping stroke when the second clip magazine is attached to the surgical device. The surgical device further comprises a strain gauge configured to measure the strain within the end effector during the first crimping stroke. The surgical device further comprises a motor controller in signal communication with the motor and the strain gauge. The motor controller is configured to move the crimping drive through a first crimping stroke with a first force. The motor controller is further configured to move the crimping drive through a second crimping stroke with a second force different than the first force. The second force is at least partially determined by the strain measured during the first crimping stroke.

Example 6—The surgical device of Example 5, wherein the housing comprises a handle.

Example 7—The surgical device of Example 5, wherein the housing is couplable to a robotic system.

Example 8—The surgical device of Examples 5, 6, or 7, further comprising the second clip magazine.

Example 9—A surgical device for clipping tissue comprising a housing comprising a motor, a shaft extending from the housing, and an end effector extending from the shaft. The end effector comprises a first jaw and a second jaw. The first jaw and the second jaw are movable relative to each other between an open position and a closed position. The surgical device further comprises a first clip cartridge comprising a plurality of clips. The first clip cartridge is removably attached to the surgical device. The surgical device further comprises a second clip cartridge comprising a plurality of clips. The second clip cartridge is removably attachable to the surgical device when the first clip cartridge is not attached to the surgical device. The surgical device further comprises a feeder member configured to move each clip in the first clip cartridge and each clip in the second clip cartridge into the end effector during separate firing strokes. The surgical device further comprises a crimping drive configured to move the first jaw and the second jaw toward the closed position during a crimping stroke for each clip in the first clip cartridge and each clip in the second clip cartridge. The surgical device further comprises a strain gauge positioned in the end effector. The strain gauge is configured to measure the strain within the end effector during the crimping stroke for each clip from the first clip cartridge. The surgical device further comprises a motor controller comprising a memory configured to store the strains measured during the crimping stroke for each clip from the first clip cartridge. The motor controller further comprises a processor in signal communication with the memory and the strain gauge. The processor is configured to modify the crimping stroke for each clip from the second clip cartridge based on the strains stored in the memory.

Example 10—The surgical device of Example 9, wherein the housing comprises a handle.

Example 11—The surgical device of Example 9, wherein the housing is couplable to a robotic system.

Example 12—A surgical device for applying clips comprising a shaft extending from a housing, and an end effector extending from the shaft. The end effector comprises a first jaw comprising a first protrusion extending therefrom, and a second jaw comprising a second protrusion extending therefrom. The first jaw and the second jaw are movable relative to each other between an open position and a closed position. The first jaw and the second jaw at least partially define a receiving chamber. The surgical device further comprises a cartridge comprising a storage chamber and a plurality of clips removably positioned within the storage chamber, wherein each clip is in a storage configuration. The surgical device further comprises a firing drive configured to advance a clip positioned in the storage chamber onto the first protrusion and the second protrusion. The surgical device further comprises a crimping drive configured to move the first jaw and the second jaw to the open position during a retraction stroke. The clip positioned on the first protrusion and the second protrusion is transitioned from the storage configuration to a deployment configuration during the retraction stroke. The deployment configuration is larger than the storage configuration.

Example 13—The surgical device of Example 12, wherein the firing drive is further configured to advance the clip in the deployment configuration into the receiving chamber, wherein the crimping drive is further configured to move the first jaw and the second jaw to the closed position during a crimping stroke, and wherein the clip is crimped around the tissue of a patient during the crimping stroke.

Example 14—The surgical device of Example 13, wherein the crimped clip is released from the receiving chamber when the first jaw and the second jaw are moved to the open position during another retraction stroke of the crimping drive, and wherein another clip is transitioned from the storage configuration to the deployment configuration during the another retraction stroke.

Example 15—The surgical device of Examples 12, 13, or 14, wherein the firing drive comprises a support portion configured to support a proximal portion of a clip during the transition of the clip from the storage configuration to the deployment configuration.

Example 16—The surgical device of Examples 12, 13, 14, or 15, wherein the first jaw comprises a first cam member, wherein the second jaw comprises a second cam member, and wherein the first cam member and the second cam member interact with the crimping drive to move the first jaw and the second jaw to the open position during the retraction stroke.

Example 17—The surgical device of Examples 12, 13, 14, 15, or 16, wherein the first protrusion comprises a first angled surface, wherein the second protrusion comprises a second angled surface, and wherein the first angled surface and the second angled surface allow a clip to slide past the first protrusion and the second protrusion as the clip is advanced towards the receiving chamber.

Example 18—The surgical device of Examples 12, 13, 14, 15, 16, or 17, wherein the cartridge is releasably attachable to the surgical device.

Example 19—A surgical device for applying clips comprising a shaft extending from a housing and an end effector extending from the shaft. The end effector comprises a receiving chamber. The surgical device further comprises a plurality of clips removably positioned within a clip cartridge. The clip cartridge is releasably attachable to the surgical device. Each clip is configured to assume a plurality of states during the operation of the surgical device. The plurality of states comprises a storage state, wherein each

clip comprises a first size when in the storage state. The plurality of states further comprises a deployment state, wherein each the clip comprises a second size larger than the first size when in the deployment state. The surgical device further comprises pre-form features configured to transition a clip from the storage state to the deployment state. The surgical device further comprises a firing drive configured to advance a clip from the clip cartridge into the receiving chamber of the end effector.

Example 20—The surgical device of Example 19, further comprising a crimping drive configured to crimp a clip in the receiving chamber around the tissue of a patient during a crimping stroke.

Example 21—The surgical device of Example 20, wherein the crimped clip is released from the receiving chamber during a retraction stroke of the crimping drive, and wherein another clip is transitioned from the storage state to the deployment state during the retraction stroke.

Example 22—The surgical device of Examples 19, 20, or 21, wherein the firing drive comprises a support portion configured to support a proximal portion of a clip during the transition of the clip from the storage state to the deployment state.

Example 23—The surgical device of Example 22, wherein the support portion is further configured to support the proximal portion of the clip when the clip is advanced into the receiving chamber.

Example 24—The surgical device of Examples 19, 20, 21, 22, or 23, wherein the end effector further comprises a first jaw and a second jaw which at least partially define the receiving chamber, wherein the first jaw and the second jaw are movable relative to each other between an open position and a closed position, and wherein the pre-form features comprise a first protrusion on the first jaw and a second protrusion on the second jaw.

Example 25—The surgical device of Example 24, wherein the first protrusion comprises a first angled surface and the second protrusion comprises a second angled surface, and wherein the first angled surface and the second angled surface facilitate travel of a clip over the pre-form features as the clip is moved towards the receiving chamber.

Example 26—A surgical device for applying clips comprising a shaft extending from a housing and an end effector extending from the shaft. The end effector comprises a receiving chamber. The surgical device further comprises a plurality of clips removably positioned within the surgical device. Each clip comprises a storage configuration and a deployment configuration during the operation of the surgical device. The deployment configuration is larger than the storage configuration. The surgical device further comprises a reciprocating firing drive configured to advance a first clip in the deployment configuration into the receiving chamber. The surgical device further comprises a crimping drive movable between a fully retracted position and a fully advanced position. The crimping drive is configured to crimp the first clip in the deployment configuration when the crimping drive is moved toward the fully advanced position. The first clip is released from the receiving chamber and a second clip is transitioned to the deployment configuration when the crimping drive is moved toward the fully retracted position.

Example 27—The surgical device of Example 26, further comprising a clip magazine releasably attachable to the surgical device, wherein the clip magazine stores the plurality of clips in the storage configuration.

Example 28—The surgical device of Example 27, wherein the reciprocating firing drive is further configured to

advance a clip from the clip magazine into a deployment position, wherein the clip is transitioned to the deployment configuration in the deployment position.

Example 29—The surgical device of Example 28, wherein the end effector further comprises pre-form features configured to transition the clip from the storage configuration to the deployment configuration when the crimping drive is moved toward the fully retracted position.

Example 30—The surgical device of Examples 26, 27, 28, or 29, wherein the reciprocating firing drive comprises a support portion configured to support a proximal portion of a first clip during the transition of the first clip from the storage configuration to the deployment configuration.

Example 31—The surgical device of Example 30, wherein the support portion is further configured to support the proximal portion of the first clip during the advancement of the first clip into the receiving chamber.

Example 32—A surgical device for clipping tissue comprising a shaft comprising a longitudinal axis. The surgical device further comprises a magazine housing extending from the shaft, an end effector extending from the magazine housing, and a reloadable clip magazine releasably attachable to the magazine housing. The reloadable clip magazine is rotatable about the longitudinal axis. The reloadable clip magazine comprises a plurality of clips removably positioned within the clip magazine, a notch, and a biasing member configured to protrude into the notch when the plurality of clips have been ejected from the reloadable clip magazine into the end effector and the reloadable clip magazine has been detached from the magazine housing. The biasing member prevents the reloadable clip magazine from being re-attached to the magazine housing when the reloadable clip magazine is empty.

Example 33—The surgical device of Example 32, wherein the biasing member is moved out of engagement with the notch when at least one clip is loaded into the clip magazine.

Example 34—The surgical device of Examples 32 or 33, wherein the magazine housing comprises a protrusion configured to extend into the notch when the clip magazine is not empty and is attached to the magazine housing.

Example 35—The surgical device of Examples 32, 33, or 34, further comprising a firing member configured to eject the clips from the clip magazine into the end effector when the clip magazine is attached to the magazine housing.

Example 36—The surgical device of Example 35, wherein the end effector comprises a first jaw and a second jaw, wherein one of the first jaw and the second jaw is movable relative to the other of the first jaw and the second jaw between an open position and a closed position, and wherein the first jaw and the second jaw are configured to crimp a clip positioned in the end effector when the first jaw and the second jaw are moved toward the closed position.

Example 37—The surgical device of Examples 32, 33, 34, 35, or 36, further comprising an articulation joint rotatably connecting the magazine housing to the shaft, wherein the magazine housing is movable relative to the shaft between an un-articulated position and an articulated position.

Example 38—A surgical device for clipping tissue comprising a shaft extending from a housing and a magazine housing extending from the shaft. The magazine housing comprises a lockout release. The surgical device further comprises an end effector extending from the magazine housing and a reloadable clip magazine releasably attachable to the magazine housing. The reloadable clip magazine comprises a plurality of clips removably positioned within the clip magazine and a lockout configured to prevent the

plurality of clips from being ejected from the clip magazine when the clip magazine is not attached to the magazine housing, wherein, when the clip magazine is attached to the magazine housing, the lockout of the clip magazine is defeated by the lockout release of the magazine housing to allow the clips to be ejected from the clip magazine.

Example 39—The surgical device of Example 38, wherein the clips are ejected from the clip magazine by a firing member after the lockout is defeated.

Example 40—The surgical device of Examples 38 or 39, wherein the magazine housing further comprises a bottom portion and a top portion movable relative to the bottom portion between an open position and a closed position. The lockout release extends from the top portion.

Example 41—The surgical device of Example 40, wherein the lockout release is defeated by the lockout when the clip magazine is attached to the magazine housing and the top portion of the magazine housing is in the closed position.

Example 42—The surgical device of Examples 40 or 41, wherein the lockout release of the magazine housing comprises a protrusion extending from the top portion of the magazine housing.

Example 43—The surgical device of Example 42, wherein the lockout of the clip magazine comprises a biasing member.

Example 44—The surgical device of Example 43, wherein the protrusion of the top portion of the magazine housing engages the biasing member of the clip magazine to defeat the lockout of the clip magazine when the clip magazine is attached to the magazine housing and the top portion of the magazine housing is in the closed position.

Example 45—The surgical device of Examples 38, 39, 40, 41, 42, 43, or 44, further comprising an articulation joint rotatably connecting the magazine housing to the shaft, wherein the magazine housing is movable relative to the shaft between an un-articulated position and an articulated position.

Example 46—A surgical device for clipping tissue comprising a shaft extending from a housing, an end effector extending from the shaft, and a replaceable clip magazine operably attachable to the end effector. The end effector comprises a receiver. The replaceable clip magazine comprises a plurality of clips removably positioned therein, and a biasing member configured to prevent the plurality of clips from being ejected from the clip magazine when the clip magazine is not attached to the end effector.

Example 47—The surgical device of Example 46, wherein the clip magazine further comprises a notch, and wherein the biasing member extends into the notch when the clip magazine is empty.

Example 48—The surgical device of Example 47, wherein the end effector further comprises a protrusion configured to extend into the notch when the clip magazine is attached to the end effector, wherein the protrusion prevents the biasing member from extending into the notch.

Example 49—The surgical device of Examples 46, 47, or 48, further comprising a firing member configured to eject the clips from the clip magazine into the receiver of the end effector when the clip magazine is attached to the end effector.

Example 50—The surgical device of Example 49, wherein the end effector comprises a first jaw and a second jaw that at least partially define the receiver, wherein one of the first jaw and the second jaw is movable relative to the other of the first jaw and the second jaw between an open position and a closed position, and wherein the first jaw and

the second jaw are configured to crimp a clip positioned in the receiver when the first jaw and the second jaw are moved toward the closed position.

Example 51—The surgical device of Examples 46, 47, 48, 49, or 50, further comprising an articulation joint rotatably connecting the end effector to the shaft, wherein the end effector is movable relative to the shaft between an unarticulated position and an articulated position.

Example 52—A surgical device for clipping tissue comprising a housing comprising a motor configured to output rotary motions. The surgical device further comprises a shaft extending from the housing, and an end effector extending from the shaft. The end effector comprises a first jaw rotatably coupled to the shaft, a second jaw rotatably coupled to the shaft, and a receiving chamber. The surgical device further comprises a crimping drive configured to move the first jaw and the second jaw toward each other during a crimping stroke. The crimping drive is operably responsive to the rotary motions. The surgical device further comprises a clip magazine comprising a plurality of clips. The plurality of clips are in a storage configuration when in the clip magazine. The surgical device further comprises a reciprocating firing drive configured to move a clip from the clip magazine to a forming position in the end effector during a clip feed stroke in response to the rotary motions, wherein a clip in the forming position is in a forming configuration, and wherein the forming configuration is the same as the storage configuration. The surgical device further comprises a motor controller configured to control the reciprocating firing drive independent of the crimping drive. The motor controller is configured to actuate the motor to perform the clip feed stroke after the surgical device has been inserted into a treatment area.

Example 53—The surgical device of Example 52, further comprising a processor and a memory, wherein the motor controller is configured to control the motor via the processor and the memory.

Example 54—The surgical device of Example 53, wherein the processor is configured to execute a motor control algorithm stored in the memory to move the crimping drive through the crimping stroke independent of the clip feed stroke.

Example 55—The surgical device of Example 53, wherein the processor is configured to execute a motor control algorithm stored in the memory to advance the reciprocating firing drive through the clip feed stroke independent of the crimping stroke.

Example 56—The surgical device of Examples 52, 53, 54, or 55, wherein the clip magazine is replaceable.

Example 57—A surgical device for clipping tissue comprising a shaft extending from a housing, and an end effector extending from the shaft. The end effector comprises a first jaw, a second jaw, and a crimping drive. The first jaw and the second jaw are movable relative to each other between an open configuration and a closed configuration. The crimping drive is configured to transition the first jaw and the second jaw between the open configuration and the closed configuration. The surgical device further comprises a clip magazine comprising a plurality of clips, a feeder drive configured to move a clip from the clip magazine to a forming position in the end effector, and a control system configured to operate the surgical device in a plurality of modes. The plurality of modes comprises a first mode wherein the first jaw and the second jaw are moved toward the open configuration and the feeder drive does not move a clip from the clip magazine into the forming position, and a second mode wherein the first jaw and the second jaw are moved toward

the open configuration and the feeder drive moves a clip from the magazine into the forming position.

Example 58—The surgical device of Example 57, further comprising a motor configured to output rotary motions, wherein the crimping drive is operably responsive to the rotary motions, and wherein the feeder drive is operably responsive to the rotary motions.

Example 59—The surgical device of Examples 57 or 58, wherein the crimping drive and the feeder drive are operably independent to one another.

Example 60—The surgical device of Examples 57, 58, or 59, wherein the control system comprises a motor controller comprising a processor and a memory, wherein the motor controller is configured to control the motor based on instructions stored in the memory and executed by the processor.

Example 61—The surgical device of Example 60, wherein the processor is configured to execute a motor control algorithm stored in the memory to transition the first jaw and the second jaw towards the open configuration.

Example 62—The surgical device of Example 60, wherein the processor is configured to execute a motor control algorithm stored in the memory to move a clip from the clip magazine to the forming position in the end effector.

Example 63—The surgical device of Examples 57, 58, 59, 60, 61, or 62, wherein the clip magazine is replaceable.

Example 64—The surgical device of Examples 57, 58, 59, 60, 61, 62, or 63, wherein the clip magazine is reloadable with another plurality of clips.

Example 65—A surgical device for clipping tissue comprising a housing comprising a motor configured to output rotary motions, a shaft extending from the housing, and an end effector extending from the shaft. The end effector comprises a first jaw rotatably coupled to the shaft, and a second jaw rotatably coupled to the shaft. The surgical device further comprises a crimping drive configured to move the first jaw and the second jaw toward each other during a crimping stroke in response to the rotary motions. The surgical device further comprises a clip cartridge comprising a plurality of clips. The surgical device further comprises a firing member configured to move a clip from the clip cartridge into the end effector during a clip feed stroke in response to the rotary motions. The surgical device further comprises a motor controller configured to control the firing member independent of the crimping drive. The motor controller is configured to actuate the motor to perform the clip feed stroke after the surgical device has been inserted into a treatment area.

Example 66—The surgical device of Example 65, further comprising a processor and a memory, wherein the motor controller is configured to control the motor via the processor and the memory.

Example 67—The surgical device of Examples 65 or 66, wherein the crimping drive and the firing member are operably independent to one another.

Example 68—The surgical device of Example 66, wherein the motor controller is configured to execute a motor control algorithm stored in the memory to move the first jaw and the second jaw toward each other during the crimping stroke independent of the clip feed stroke.

Example 69—The surgical device of Example 66, wherein the motor controller is further configured to execute a motor control algorithm stored in the memory to advance the firing member through the clip feed stroke independent of the crimping stroke.

71

Example 70—The surgical device of Examples 65, 66, 67, 68, or 69, wherein the clip cartridge is replaceable with another clip cartridge comprising another plurality of clips.

Example 71—The surgical device of Examples 65, 66, 67, 68, 69, or 70, wherein the clip cartridge is reloadable with another plurality of clips.

Example 72—A surgical device for clipping tissue comprising a housing comprising a motor configured to output rotary motions, a power source configured to supply power to the motor, a current meter configured to measure the current draw of the motor, a shaft extending from the housing, and an end effector extending from the shaft. The end effector comprises a first jaw rotatably coupled to the shaft, a second jaw rotatably coupled to the shaft, and a receiver. The surgical device further comprises a crimping drive configured to move the first jaw and the second jaw towards each other during a crimping stroke. The crimping drive is operably responsive to the rotary motions. The surgical device further comprises a clip magazine comprising a plurality of clips, and a reciprocating firing drive configured to advance a clip from the clip magazine into the receiver of the end effector during a firing stroke. The reciprocating firing drive is operably responsive to the rotary motions. The surgical device further comprises a motor controller connected to the current meter. The motor controller is configured to adjust the speed of the firing stroke when the current draw of the motor reaches a threshold value.

Example 73—The surgical device of Example 72, wherein after the speed of the firing stroke is adjusted and the current draw of the motor still exceeds the threshold value, the motor controller is configured to stop the motor.

Example 74—The surgical device of Example 72, wherein after the speed of the firing stroke is adjusted and the current draw of the motor still exceeds the threshold value, the motor controller is configured to reverse the direction of the motor to retract the firing member through a short stroke distance.

Example 75—The surgical device of Example 74, wherein the crimping drive is further configured to move the first jaw and the second jaw away from each other during a retraction stroke.

Example 76—The surgical device of Example 75, wherein after the firing member is retracted through the short stroke distance the motor controller is further configured to move the crimping drive through the retraction stroke.

Example 77—The surgical device of Examples 72, 73, 74, 75, or 76, wherein the clip magazine is removably attachable to the surgical device.

Example 78—The surgical device of Examples 72, 73, 74, 75, 76, or 77, wherein the clip magazine is configured to be reloaded with another plurality of clips when the clip magazine has been spent.

Example 79—A surgical device for clipping tissue comprising a housing comprising a motor configured to output rotary motions, a power source configured to supply power to the motor, a motor controller configured to control the motor, a current meter configured to measure the current draw of the motor, a shaft extending from the housing, and an end effector extending from the shaft. The end effector comprises a first jaw and a second jaw. The first jaw and the second jaw are movable between a fully open position, an open position, and a closed position relative to each other. The surgical device further comprises a crimping drive configured to move the first jaw and the second jaw relative to each other between the fully open position, the open

72

position, and the closed position. The surgical device further comprises a clip magazine comprising a plurality of clips. The surgical device further comprises a reciprocating firing drive configured to advance a clip from the clip magazine into the end effector during a firing stroke. The reciprocating firing drive is operably responsive to the rotary motions, wherein when a clip is jammed in the end effector the current meter is configured to detect the jammed clip and the crimping drive is configured to move the first jaw and the second jaw to the fully open position.

Example 80—The surgical device of Example 79, wherein the crimping drive is operably responsive to the rotary motions.

Example 81—The surgical device of Examples 79 or 80, wherein the motor controller is in signal communication with the motor and the current meter.

Example 82—The surgical device of Examples 79, 80, or 81, wherein the current meter is configured to measuring the current draw of the motor, and wherein the current meter detects the jammed clip when the current draw of the motor exceeds a threshold value.

Example 83—The surgical device of Examples 79, 80, 81, or 82, wherein the first jaw and the second jaw comprise protrusions, and wherein the protrusions are operably engaged by the crimping drive to move the first jaw and the second jaw to the fully open position when the current meter detects the jammed clip.

Example 84—The surgical device of Examples 79, 80, 81, 82, or 83, wherein the motor controller is configured to retract the reciprocating firing drive a short stroke distance when the current meter detects the jammed clip.

Example 85—The surgical device of Examples 79, 80, 81, 82, 83, or 84, wherein the clip magazine is removably attachable to the surgical device.

Example 86—The surgical device of Examples 79, 80, 81, 82, 83, 84, or 85, wherein the clip magazine is configured to be reloaded with another plurality of clips when the clip magazine has been spent.

Example 87—A surgical device for clipping tissue comprising a housing comprising a motor. The surgical device further comprises a shaft extending from the housing, a current sensor configured to measure the current draw of the motor, and an end effector extending from the shaft. The end effector comprises a first jaw and a second jaw. The first jaw and the second jaw are movable relative to each other between an open position and a closed position. The surgical device further comprises a clip cartridge configured to store a plurality of clips. The surgical device further comprises a feeder member configured to advance a clip from the clip cartridge during a firing stroke. The feeder member is further configured to retract during a retraction stroke. The feeder member is operably responsive to the rotary motions. The surgical device further comprises a closure tube configured to move the first jaw and the second jaw toward the open position during a retraction stroke. The closure tube is operably responsive to the rotary motions. The surgical device further comprises a motor controller in signal communication with the current sensor and the motor. The motor controller is configured to move the feeder member through the retraction stroke and move the closure tube through the retraction stroke when the current sensor detects a current draw that exceeds a threshold value.

Example 88—The surgical device of Example 87, wherein the threshold value is indicative of a clip which has been jammed in the end effector.

Example 89—The surgical device of Examples 87 or 88, wherein the first jaw and the second jaw comprise protrusions.

sions, and wherein the protrusions are operably engaged by the closure tube during the retraction stroke of the closure tube.

Example 90—The surgical device of Examples 87, 88, or 89, wherein the clip cartridge is removably attachable to the surgical device.

Example 91—The surgical device of Examples 87, 88, 89, or 90, wherein the clip cartridge is configured to be reloaded with another plurality of clips when the clip cartridge has been spent.

Example 92—A surgical device for clipping tissue comprising a housing. The housing comprising a motor configured to output rotary motions. The surgical device further comprises a shaft extending from the housing and an end effector extending from the shaft. The end effector comprises a first jaw rotatably coupled to the shaft, a second jaw rotatably coupled to the shaft, and a receiver. The surgical device further comprises a clip magazine comprising a plurality of clips. The surgical device further comprises a reciprocating firing drive operably responsive to the rotary motions. The firing drive is configured to move a clip from the clip magazine into the receiver. The surgical device further comprises a crimping drive operably responsive to the rotary motions. The crimping drive is configured to move the first jaw and the second jaw towards each other during a crimping stroke, wherein a clip positioned in the receiver is crimped during the crimping stroke. The surgical device further comprises a strain gauge positioned in at least one of the first jaw and the second jaw. The strain gauge is configured to measure the strain within the end effector during the crimping stroke. The surgical device further comprises a motor controller in communication with the motor and the strain gauge, wherein the motor controller is configured to adjust the output torque of the motor based on the measured strain in the strain gauge during the crimping stroke.

Example 93—The surgical device of Example 92, wherein the strain gauge comprises a proximal strain gauge, and where the surgical device further comprises a distal strain gauge positioned in at least one of the first jaw and the second jaw.

Example 94—The surgical device of Example 93, wherein the proximal strain gauge is configured to measure a first strain in the end effector during the crimping stroke, and wherein the distal strain gauge is configured to measure a second strain in the end effector during the crimping stroke.

Example 95—The surgical device of Example 94, wherein the motor controller is configured to adjust the output torque of the motor based on the difference between the first strain and the second strain during the crimping stroke.

Example 96—The surgical device of Examples 92, 93, 94, or 95, wherein the clip magazine is removably attachable to the surgical device.

Example 97—A surgical device for clipping tissue comprising a housing. The housing comprising a motor configured to output rotary motions. The surgical device further comprises a shaft extending from the housing and an end effector extending from the shaft. The end effector comprises a first jaw and a second jaw. The first jaw and the second jaw are movable relative to each other between an open position and a closed position. The surgical device further comprises a crimping drive configured to move the first jaw and the second jaw to a closed position during a crimping stroke. The crimping drive is operably responsive to the rotary motions. The surgical device further comprises

a clip magazine comprising a plurality of metal clips, a firing drive configured to move a metal clip from the clip magazine into the end effector, a first resistive sensing circuit configured to detect the position of the metal clip in the end effector, and a second resistive sensing circuit configured to determine whether the first jaw and the second jaw are in the open position or the closed position.

Example 98—The surgical device of Example 97, further comprising a power source, wherein the first resistive sensing circuit comprises the power source, the first jaw, a metal clip positioned in the end effector, the second jaw, a resistor, and a current meter.

Example 99—The surgical device of Example 98, wherein the power source is configured to supply a current to the first resistive sensing circuit, wherein the current meter is configured to measure an output current of the first resistive sensing circuit.

Example 100—The surgical device of Example 99, wherein the output current measured at the current meter is indicative of the position of the clip in the end effector.

Example 101—The surgical device of Example 97, further comprising a power source, wherein the second resistive sensing circuit comprises the power source, a first lead in the first jaw, a second lead in the second jaw, a resistor, and a current meter.

Example 102—The surgical device of Example 101, wherein the first lead is insulated from the first jaw, and wherein the second lead is insulated from the second jaw.

Example 103—The surgical device of Examples 101 or 102, wherein the power source is configured to supply a current to the second resistive sensing circuit, and wherein the current meter is configured to measure an output current of the second resistive sensing circuit.

Example 104—The surgical device of Example 103, wherein the output current measured at the current meter is indicative of the position of the first jaw relative to the second jaw.

Example 105—The surgical device of Examples 97, 98, 99, 100, 101, 102, 103, or 104, wherein the clip magazine is removably attachable to the surgical device.

Example 106—A surgical device for clipping tissue comprising a housing. The housing comprises a motor configured to output rotary motions. The surgical device further comprises a shaft extending from the housing and an end effector extending from the shaft. The end effector comprises a first jaw rotatably coupled to the shaft, a second jaw rotatably coupled to the shaft, and a receiver. The surgical device further comprises a crimping drive configured to move the first jaw and the second jaw towards each other during a crimping stroke. The crimping drive is operably responsive to the rotary motions. The surgical device further comprises a clip magazine comprising a plurality of clips. Each clip is stored in the clip magazine in a stored configuration. The surgical device further comprises a reciprocating firing drive configured to move a clip from the magazine to a forming position in the end effector during a clip feed stroke. The clip in the forming position is in a forming configuration that is the same as the stored configuration. The surgical device further comprises a resistive sensing circuit configured to detect when a clip is in the forming position. The crimping drive is further configured to expand the clip in the forming configuration to a deployable configuration that is larger than the forming configuration after the resistive sensing circuit detects the clip in the forming position.

Example 107—The surgical device of Example 106, wherein the resistive sensing circuit comprises a power

supply configured to supply a voltage to the end effector, a current meter, and a resistor, and wherein the current meter is configured to measure the current at the resistor.

Example 108—The surgical device of Example 107, wherein the current measured at the resistor is indicative of the position of a clip in the end effector.

Example 109—The surgical device of Examples 107 or 108, wherein when a clip is in the forming position the current measured by the current meter is a first current, wherein when a clip is in the deployable configuration the current measured by the current meter is a second current, and wherein the second current is smaller than the first current.

Example 110—The surgical device of Examples 106, 107, 108, or 109, wherein the clip magazine is removably attachable to the surgical device.

Example 111—The surgical device of Examples 106, 107, 108, 109, or 110, wherein the clip magazine is configured to be reloaded with another plurality of clips when the plurality of clips have been spent.

The devices, systems, and methods disclosed in the Subject Application can be used with the devices, systems, and methods disclosed in U.S. Provisional Patent Application Ser. No. 62/659,900, entitled METHOD OF HUB COMMUNICATION, filed Apr. 19, 2018; U.S. Provisional Patent Application Ser. No. 62/611,341, entitled INTERACTIVE SURGICAL PLATFORM, filed Dec. 28, 2017; U.S. Provisional Patent Application Ser. No. 62/611,340, entitled CLOUD-BASED MEDICAL ANALYTICS, filed Dec. 28, 2017; and U.S. Provisional Patent Application Ser. No. 62/611,339, entitled ROBOT ASSISTED SURGICAL PLATFORM, filed Dec. 28, 2017.

The devices, systems, and methods disclosed in the Subject Application can also be used with the devices, systems, and methods disclosed in U.S. patent application Ser. No. 15/908,021, entitled SURGICAL INSTRUMENT WITH REMOTE RELEASE, filed Feb. 28, 2018; U.S. patent application Ser. No. 15/908,012, entitled SURGICAL INSTRUMENT HAVING DUAL ROTATABLE MEMBERS TO EFFECT DIFFERENT TYPES OF END EFFECTOR MOVEMENT, filed Feb. 28, 2018; U.S. patent application Ser. No. 15/908,040, entitled SURGICAL INSTRUMENT WITH ROTARY DRIVE SELECTIVELY ACTUATING MULTIPLE END EFFECTOR FUNCTIONS, filed Feb. 28, 2018; U.S. patent application Ser. No. 15/908,057, entitled SURGICAL INSTRUMENT WITH ROTARY DRIVE SELECTIVELY ACTUATING MULTIPLE END EFFECTOR FUNCTIONS, filed Feb. 28, 2018; U.S. patent application Ser. No. 15/908,058, entitled SURGICAL INSTRUMENT WITH MODULAR POWER SOURCES, filed Feb. 28, 2018; and U.S. patent application Ser. No. 15/908,143, entitled SURGICAL INSTRUMENT WITH SENSOR AND/OR CONTROL SYSTEMS, filed Feb. 28, 2018.

The surgical instrument systems described herein can be used in connection with the deployment and deformation of staples. Various embodiments are envisioned which deploy fasteners other than staples, such as clamps or tacks, for example. Moreover, various embodiments are envisioned which utilize any suitable means for sealing tissue. For instance, an end effector in accordance with various embodiments can comprise electrodes configured to heat and seal the tissue. Also, for instance, an end effector in accordance with certain embodiments can apply vibrational energy to seal the tissue. In addition, various embodiments are envisioned which utilize a suitable cutting means to cut the tissue.

The entire disclosures of:

U.S. Pat. No. 8,075,571, entitled SURGICAL CLIP APPLIER METHODS, which issued on Dec. 13, 2011; U.S. Pat. No. 8,038,686, entitled CLIP APPLIER CONFIGURED TO PREVENT CLIP FALLOUT, which issued on Oct. 18, 2011;

U.S. Pat. No. 7,699,860, entitled SURGICAL CLIP, which issued on Apr. 20, 2010;

U.S. patent application Ser. No. 11/013,924, entitled TROCAR SEAL ASSEMBLY, now U.S. Pat. No. 7,371,227;

U.S. patent application Ser. No. 11/162,991, entitled ELECTROACTIVE POLYMER-BASED ARTICULATION MECHANISM FOR GRASPER, now U.S. Pat. No. 7,862,579;

U.S. patent application Ser. No. 12/364,256, entitled SURGICAL DISSECTOR, now U.S. Patent Application Publication No. 2010/0198248;

U.S. patent application Ser. No. 13/536,386, entitled EMPTY CLIP CARTRIDGE LOCKOUT, now U.S. Pat. No. 9,282,974;

U.S. patent application Ser. No. 13/832,786, entitled CIRCULAR NEEDLE APPLIER WITH OFFSET NEEDLE AND CARRIER TRACKS, now U.S. Pat. No. 9,398,905;

U.S. patent application Ser. No. 12/592,174, entitled APPARATUS AND METHOD FOR MINIMALLY INVASIVE SUTURING, now U.S. Pat. No. 8,123,764;

U.S. patent application Ser. No. 12/482,049, entitled ENDOSCOPIC STITCHING DEVICES, now U.S. Pat. No. 8,628,545;

U.S. patent application Ser. No. 13/118,241, entitled SURGICAL STAPLING INSTRUMENTS WITH ROTATABLE STAPLE DEPLOYMENT ARRANGEMENTS, now U.S. Pat. No. 9,072,535;

U.S. patent application Ser. No. 11/343,803, entitled SURGICAL INSTRUMENT HAVING RECORDING CAPABILITIES, now U.S. Pat. No. 7,845,537;

U.S. patent application Ser. No. 14/200,111, entitled CONTROL SYSTEMS FOR SURGICAL INSTRUMENTS, now U.S. Pat. No. 9,629,629;

U.S. patent application Ser. No. 14/248,590, entitled MOTOR DRIVEN SURGICAL INSTRUMENTS WITH LOCKABLE DUAL DRIVE SHAFTS, now U.S. Pat. No. 9,826,976;

U.S. patent application Ser. No. 14/813,242, entitled SURGICAL INSTRUMENT COMPRISING SYSTEMS FOR ASSURING THE PROPER SEQUENTIAL OPERATION OF THE SURGICAL INSTRUMENT, now U.S. Patent Application Publication No. 2017/0027571;

U.S. patent application Ser. No. 14/248,587, entitled POWERED SURGICAL STAPLER, now U.S. Pat. No. 9,867,612;

U.S. patent application Ser. No. 12/945,748, entitled SURGICAL TOOL WITH A TWO DEGREE OF FREEDOM WRIST, now U.S. Pat. No. 8,852,174;

U.S. patent application Ser. No. 13/297,158, entitled METHOD FOR PASSIVELY DECOUPLING TORQUE APPLIED BY A REMOTE ACTUATOR INTO AN INDEPENDENTLY ROTATING MEMBER, now U.S. Pat. No. 9,095,362;

International Application No. PCT/US2015/023636, entitled SURGICAL INSTRUMENT WITH SHIFTABLE TRANSMISSION, now International Patent Publication No. WO 2015/153642 A1;

International Application No. PCT/US2015/051837, entitled HANDHELD ELECTROMECHANICAL SURGICAL SYSTEM, now International Patent Publication No. WO 2016/057225 A1;

U.S. patent application Ser. No. 14/657,876, entitled SURGICAL GENERATOR FOR ULTRASONIC AND ELECTROSURGICAL DEVICES, U.S. Patent Application Publication No. 2015/0182277;

U.S. patent application Ser. No. 15/382,515, entitled MODULAR BATTERY POWERED HANDHELD SURGICAL INSTRUMENT AND METHODS THEREFOR, U.S. Patent Application Publication No. 2017/0202605;

U.S. patent application Ser. No. 14/683,358, entitled SURGICAL GENERATOR SYSTEMS AND RELATED METHODS, U.S. Patent Application Publication No. 2016/0296271;

U.S. patent application Ser. No. 14/149,294, entitled HARVESTING ENERGY FROM A SURGICAL GENERATOR, U.S. Pat. No. 9,795,436;

U.S. patent application Ser. No. 15/265,293, entitled TECHNIQUES FOR CIRCUIT TOPOLOGIES FOR COMBINED GENERATOR, U.S. Patent Application Publication No. 2017/0086910; and

U.S. patent application Ser. No. 15/265,279, entitled TECHNIQUES FOR OPERATING GENERATOR FOR DIGITALLY GENERATING ELECTRICAL SIGNAL WAVEFORMS AND SURGICAL INSTRUMENTS, U.S. Patent Application Publication No. 2017/0086914, are hereby incorporated by reference herein.

The devices disclosed herein can be designed to be disposed of after a single use, or they can be designed to be used multiple times. In either case, however, a device can be reconditioned for reuse after at least one use. Reconditioning can include any combination of the steps including, but not limited to, the disassembly of the device, followed by cleaning or replacement of particular pieces of the device, and subsequent reassembly of the device. In particular, a reconditioning facility and/or surgical team can disassemble a device and, after cleaning and/or replacing particular parts of the device, the device can be reassembled for subsequent use. Those skilled in the art will appreciate that reconditioning of a device can utilize a variety of techniques for disassembly, cleaning/replacement, and reassembly. Use of such techniques, and the resulting reconditioned device, are all within the scope of the present application.

The devices disclosed herein may be processed before surgery. First, a new or used instrument may be obtained and, when necessary, cleaned. The instrument may then be sterilized. In one sterilization technique, the instrument is placed in a closed and sealed container, such as a plastic or TYVEK bag. The container and instrument may then be placed in a field of radiation that can penetrate the container, such as gamma radiation, x-rays, and/or high-energy electrons. The radiation may kill bacteria on the instrument and in the container. The sterilized instrument may then be stored in the sterile container. The sealed container may keep the instrument sterile until it is opened in a medical facility. A device may also be sterilized using any other technique known in the art, including but not limited to beta radiation, gamma radiation, ethylene oxide, plasma peroxide, and/or steam.

While this invention has been described as having exemplary designs, the present invention may be further modified within the spirit and scope of the disclosure. This application

is therefore intended to cover any variations, uses, or adaptations of the invention using its general principles.

Any patent, publication, or other disclosure material, in whole or in part, that is said to be incorporated by reference herein is incorporated herein only to the extent that the incorporated materials do not conflict with existing definitions, statements, or other disclosure material set forth in this disclosure. As such, and to the extent necessary, the disclosure as explicitly set forth herein supersedes any conflicting material incorporated herein by reference. Any material, or portion thereof, that is said to be incorporated by reference herein, but which conflicts with existing definitions, statements, or other disclosure material set forth herein will only be incorporated to the extent that no conflict arises between that incorporated material and the existing disclosure material.

What is claimed is:

1. A surgical device for clipping tissue, comprising:

a shaft comprising a longitudinal axis;

a magazine housing extending from said shaft;

an end effector extending from said magazine housing; and

a reloadable clip magazine releasably attachable to said magazine housing, wherein said reloadable clip magazine is rotatable about said longitudinal axis, and wherein said reloadable clip magazine comprises:

a plurality of clips removably positioned within said clip magazine;

a notch; and

a biasing member configured to protrude into said notch when said plurality of clips have been ejected from said reloadable clip magazine into said end effector and said reloadable clip magazine has been detached from said magazine housing, wherein said biasing member prevents said reloadable clip magazine from being re-attached to said magazine housing when said reloadable clip magazine is empty.

2. The surgical device of claim 1, wherein said biasing member is moved out of engagement with said notch when at least one clip is loaded into said clip magazine.

3. The surgical device of claim 1, further comprising an articulation joint rotatably connecting said magazine housing to said shaft, wherein said magazine housing is movable relative to said shaft between an un-articulated position and an articulated position.

4. A surgical device for clipping tissue, comprising:

a shaft comprising a longitudinal axis;

a magazine housing extending from said shaft;

an end effector extending from said magazine housing; and

a reloadable clip magazine releasably attachable to said magazine housing, wherein said reloadable clip magazine is rotatable about said longitudinal axis, and wherein said reloadable clip magazine comprises:

a plurality of clips removably positioned within said clip magazine;

a notch; and

a biasing member configured to protrude into said notch when said plurality of clips have been ejected from said reloadable clip magazine into said end effector and said reloadable clip magazine has been detached from said magazine housing, wherein said biasing member prevents said reloadable clip magazine from being re-attached to said magazine housing when said reloadable clip magazine is empty, wherein said biasing member is moved out of engagement with said notch when at least one clip is

79

loaded into said clip magazine, and wherein said magazine housing comprises a protrusion configured to extend into said notch when said clip magazine is not empty and is attached to said magazine housing.

5 **5.** The surgical device of claim **4**, further comprising a firing member configured to eject said plurality of clips from said clip magazine into said end effector when said clip magazine is attached to said magazine housing.

6. The surgical device of claim **5**, wherein said end effector comprises a first jaw and a second jaw, wherein one of said first jaw and said second jaw is movable relative to the other of said first jaw and said second jaw between an open position and a closed position, and wherein said first jaw and said second jaw are configured to crimp a said clip positioned in said end effector when said first jaw and said second jaw are moved toward said closed position.

7. A surgical device for clipping tissue, comprising:

a shaft extending from a housing;

a magazine housing extending from said shaft, wherein said magazine housing comprises a lockout release; an end effector extending from said magazine housing; and

a reloadable clip magazine releasably attachable to said magazine housing, wherein said reloadable clip magazine comprises:

a plurality of clips removably positioned within said clip magazine; and

a lockout configured to prevent said plurality of clips from being ejected from said clip magazine when said clip magazine is not attached to said magazine housing, wherein, when said clip magazine is attached to said magazine housing, said lockout of said clip magazine is defeated by said lockout release of said magazine housing to allow said plurality of clips to be ejected from said clip magazine.

8. The surgical device of claim **7**, wherein said plurality of clips are ejected from said clip magazine by a firing member after said lockout is defeated.

9. The surgical device of claim **7**, further comprising an articulation joint rotatably connecting said magazine housing to said shaft, wherein said magazine housing is movable relative to said shaft between an un-articulated position and an articulated position.

10. A surgical device for clipping tissue, comprising:

a shaft extending from a housing;

a magazine housing extending from said shaft, wherein said magazine housing comprises a lockout release; an end effector extending from said magazine housing; and

a reloadable clip magazine releasably attachable to said magazine housing, wherein said reloadable clip magazine comprises:

a plurality of clips removably positioned within said clip magazine; and

a lockout configured to prevent said plurality of clips from being ejected from said clip magazine when said clip magazine is not attached to said magazine housing, wherein, when said clip magazine is attached to said magazine housing, said lockout of said clip magazine is defeated by said lockout release of said magazine housing to allow said plurality of clips to be ejected from said clip magazine, wherein said plurality of clips are ejected from said clip magazine by a firing member after said lockout is

80

defeated, and wherein said magazine housing further comprises:

a bottom portion; and

a top portion movable relative to said bottom portion between an open position and a closed position, wherein said lockout release extends from said top portion.

11. The surgical device of claim **10**, wherein said lockout release is defeated by said lockout when said clip magazine is attached to said magazine housing and said top portion of said magazine housing is in said closed position.

12. The surgical device of claim **11**, wherein said lockout release of said magazine housing comprises a protrusion extending from said top portion of said magazine housing.

13. The surgical device of claim **12**, wherein said lockout of said clip magazine comprises a biasing member.

14. The surgical device of claim **13**, wherein said protrusion of said top portion of said magazine housing engages said biasing member of said clip magazine to defeat said lockout of said clip magazine when said clip magazine is attached to said magazine housing and said top portion of said magazine housing is in said closed position.

15. A surgical device for clipping tissue, comprising:

a shaft extending from a housing;

an end effector extending from said shaft, wherein said end effector comprises a receiver; and

a replaceable clip magazine operably attachable to said end effector, wherein said replaceable clip magazine comprises:

a plurality of clips removably positioned therein; and a biasing member configured to prevent said plurality of clips from being ejected from said clip magazine when said clip magazine is not attached to said end effector, wherein said biasing member prevents said replaceable clip magazine from being re-attached to said end effector when said replaceable clip magazine is empty.

16. The surgical device of claim **15**, wherein said clip magazine further comprises a notch, and wherein said biasing member extends into said notch when said clip magazine is empty.

17. The surgical device of claim **15**, further comprising an articulation joint rotatably connecting said end effector to said shaft, wherein said end effector is movable relative to said shaft between an un-articulated position and an articulated position.

18. A surgical device for clipping tissue, comprising:

a shaft extending from a housing;

an end effector extending from said shaft, wherein said end effector comprises a receiver; and

a replaceable clip magazine operably attachable to said end effector, wherein said replaceable clip magazine comprises:

a plurality of clips removably positioned therein; and a biasing member configured to prevent said plurality of clips from being ejected from said clip magazine when said clip magazine is not attached to said end effector, wherein said clip magazine further comprises a notch, wherein said biasing member extends into said notch when said clip magazine is empty, wherein said end effector further comprises a protrusion configured to extend into said notch when said clip magazine is attached to said end effector, and wherein said protrusion prevents said biasing member from extending into said notch.

19. The surgical device of claim 18, further comprising a firing member configured to eject said plurality of clips from said clip magazine into said receiver of said end effector when said clip magazine is attached to said end effector.

20. The surgical device of claim 19, wherein said end effector comprises a first jaw and a second jaw that at least partially define said receiver, wherein one of said first jaw and said second jaw is movable relative to the other of said first jaw and said second jaw between an open position and a closed position, and wherein said first jaw and said second jaw are configured to crimp a said clip positioned in said receiver when said first jaw and said second jaw are moved toward said closed position.

* * * * *