



(51) International Patent Classification:
E05D 15/24 (2006.01)

(21) International Application Number:

PCT/EP2017/065718

(22) International Filing Date:

26 June 2017 (26.06.2017)

(25) Filing Language:

English

(26) Publication Language:

English

(30) Priority Data:

1630166-5 29 June 2016 (29.06.2016) SE

(71) Applicant: ASSA ABLOY ENTRANCE SYSTEMS AB
[SE/SE]; Box 131, 261 22 LANDSKRONA (SE).

(72) Inventor: BRÄNNSTRÖM, Mats; Sörstigen 9, 931 56
Skellefteå (SE).

(74) Agent: KARLSSON, Per-Tomas; ASSA ABLOY En-
trance Systems AB, Box 131, 261 22 LANDSKRONA
(SE).

(81) Designated States (unless otherwise indicated, for every
kind of national protection available): AE, AG, AL, AM,
AO, AT, AU, AZ, BA, BB, BG, BH, BN, BR, BW, BY, BZ,
CA, CH, CL, CN, CO, CR, CU, CZ, DE, DJ, DK, DM, DO,
DZ, EC, EE, EG, ES, FI, GB, GD, GE, GH, GM, GT, HN,
HR, HU, ID, IL, IN, IR, IS, JO, JP, KE, KG, KH, KN, KP,
KR, KW, KZ, LA, LC, LK, LR, LS, LU, LY, MA, MD, ME,
MG, MK, MN, MW, MX, MY, MZ, NA, NG, NI, NO, NZ,
OM, PA, PE, PG, PH, PL, PT, QA, RO, RS, RU, RW, SA,

SC, SD, SE, SG, SK, SL, SM, ST, SV, SY, TH, TJ, TM, TN,
TR, TT, TZ, UA, UG, US, UZ, VC, VN, ZA, ZM, ZW.

(84) Designated States (unless otherwise indicated, for every
kind of regional protection available): ARIPO (BW, GH,
GM, KE, LR, LS, MW, MZ, NA, RW, SD, SL, ST, SZ, TZ,
UG, ZM, ZW), Eurasian (AM, AZ, BY, KG, KZ, RU, TJ,
TM), European (AL, AT, BE, BG, CH, CY, CZ, DE, DK,
EE, ES, FI, FR, GB, GR, HR, HU, IE, IS, IT, LT, LU, LV,
MC, MK, MT, NL, NO, PL, PT, RO, RS, SE, SI, SK, SM,
TR), OAPI (BF, BJ, CF, CG, CI, CM, GA, GN, GQ, GW,
KM, ML, MR, NE, SN, TD, TG).

Published:

— with international search report (Art. 21(3))

(54) Title: FLOOR PIT COVERING SYSTEM

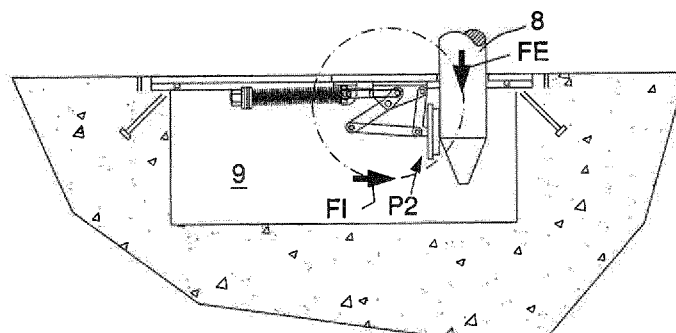

FIG.2B

(57) Abstract: The present invention relates to a floor pit covering system comprising a cover plate (1) and a pivoting system (2). The pivoting system (2) is adapted for arranging the cover plate (1) in a first end position (P1) or in a second end position (P2) in response to an internal force (FI), or an internal force (FI) and an external force (FE), being applied onto the cover plate (1). The cover plate (1) is arranged in the first end position (P1) when force $FE \leq FI$ and in the second end position (P2) when force $FE > FI$. The present invention further relates to a method of operating such a system.



FLOOR PIT COVERING SYSTEM

Field of the invention

The present invention relates to a floor pit covering system to be used primarily in
5 relation to large vertical lifting doors, and a method of operating such a system.

Background of the invention

Vertical lifting doors are frequently used for extremely large door openings, such as
those of aircraft hangars and shipyard halls. In certain applications, it may be advantageous
10 to split a large opening into two or more smaller openings using a pivotable mullion system.
Such a solution increases the flexibility of the door system, while also saving energy.

The lower end of a conventional mullion is provided with a pin which is to be inserted
into a corresponding floor pit. In order to avoid accidents, e.g. caused by stepping into a floor
pit, and to allow vehicles to pass over a floor surfaces, each floor pit is provided with a pivotable
15 cover plate, covering the floor pit opening. These cover plates have to be opened and closed
manually, which is a heavy and time consuming process. Further, opening/closing of one or
more floor pits could easily be forgotten, resulting in damage to personnel, doors or vehicles.

Summary of the invention

20 It is an object of the present invention to mitigate the above problems, and to provide
a floor pit covering system which can be constructed by standard components. According to a
first aspect of the present invention, these objects are achieved by a floor pit covering system
comprising a cover plate and a pivoting system, the pivoting system being adapted for
arranging the cover plate in a first end position or in a second end position in response to an
25 internal force, or an internal force and an external force, being applied onto the cover plate,
the cover plate being arranged in the first end position when force $FE \leq FI$ and in the second
end position when force $FE > FI$.

Such a solution allows the floor pit covering system to be operated automatically
without personnel having to open each floor pit manually. Further, the risk of damaging the
30 mullion, the motorized base pin, the mullion lifting cable or the floor pit covers is significantly
reduced. Further, the tripping hazard is greatly reduced as well as the risk of personal injury
from stepping into an opening in the floor.

In one embodiment, the pivoting system comprises an articulated joint system and at
least one spring, constituting a simple and well-tried solution for transferring forces between
35 vertical and horizontal directions.

The internal force may be generated by the spring.

The cover plate may be arranged at a first end of the articulated joint system, and the spring may be arranged at a second end of the articulated joint system, such that the length of the articulated joint system is kept to a minimum.

In one embodiment, the articulated joint system comprises a plurality of interconnected components.

In a further embodiment, the spring is compressed when the cover plate is arranged in the second end position, allowing the internal force, generated by the spring, to move and hold the cover plate in the first end position as long as no external force is generated by a mullion pin.

The first end position may be a horizontal position and the second end position may be a vertical position.

In one embodiment, the floor pit is closed when the cover plate is arranged in said first end position, and the floor pit is open when the cover plate is arranged in the second end position, restricting the floor pit to the options of either being closed or receiving a mullion pin.

According to a second aspect of the present invention, these objects are achieved by a method of operating a floor pit covering system according to the above, comprising the steps of: applying an internal force onto the cover plate such that the cover plate is held in a first end position, applying an external force onto the cover plate, moving the cover plate to a second end position when force $FE > FI$, holding the cover plate in the second end position as long as force $FE > FI$, removing the external force from the cover plate, returning the cover plate to the first end position when force $FE \leq FI$. This method allows the floor pit covering system to be operated automatically without personnel having to open each floor pit manually. Further, the risk of damaging the mullion, the motorized base pin, the mullion lifting cable or the floor pit covers is significantly reduced. Further, the tripping hazard is greatly reduced as well as the risk of personal injury from stepping into an opening in the floor.

In one embodiment, the first end position is a horizontal position, and the second end position is a vertical position.

In a further embodiment, the floor pit is closed when the cover plate is arranged in the first end position, and the floor pit is open when the cover plate is arranged in the second end position, restricting the floor pit to the options of either being closed or receiving a mullion pin.

Generally, all terms used in the claims are to be interpreted according to their ordinary meaning in the technical field, unless explicitly defined otherwise herein. All references to "a/an/the [element, device, component, means, etc.]" are to be interpreted openly as referring to at least one instance of said element, device, component, means, etc., unless explicitly stated otherwise. Further, by the term "comprising" it is meant "comprising but not limited to" throughout the application.

Brief description of the drawings

This and other aspects of the present invention will now be described in more detail, with reference to the appended drawings showing a currently preferred embodiment of the invention.

5 Figure 1 shows a schematic front view of a vertical lifting door provided with pivotable mullions.

 Figure 2A shows a schematic side view of an embodiment of the floor pit covering system according to the present invention, wherein the floor pit cover system is in a closed position.

10 Figure 2B shows a schematic side view of the embodiment of Fig. 2A, wherein the floor pit cover system is in an open position, interacting with a mullion pin.

 Figure 3 shows a schematic side view of the embodiment of Fig. 2A, showing only the cover plate and the pivoting system.

 Figure 4 shows a schematic and partial top view of the embodiment of Fig. 2A.

15

Detailed description

As previously mentioned, vertical lifting doors are used when covering extremely large door openings. A very large door opening may be split into several smaller door openings using smaller door sections 5 and pivotable mullions 6 arranged between each such door section, as shown in Fig. 1. Fig. 1 shows three door sections 5, arranged side by side, and one mullion 6 arranged between each adjacent pair of door sections 5.

Each mullion 6 is hinged, at its upper end, to the upper edge of the door opening. Further, each mullion 6 is connected to lifting means, such as cables 7. Consequently, the mullion 6 is upwardly foldable and of a so called "swing-up mullion" type. The opposite, lower end of the swing-up mullion 6 only rests against a floor, such as a concrete floor, when the mullion extends completely vertically, i.e. when the door opening is to be, at least partially, sealed off using the above mentioned door sections 5.

In order to fixate the mullion 6 in its vertical position, its lower end has to interconnect with the floor. Conventionally, the lower end is provided with axially movable locking means such as a pin 8. The pin 8 is operated by means of a motor, and is slid, from the interior of the mullion 6, vertically downwards such that it protrudes from the end of the mullion into a corresponding opening in the floor, a floor pit 9. Correspondingly, when the mullion 6 is to be folded upwards, the pin is moved axially back into the interior of the mullion 6.

The present invention relates to a floor pit covering system used for automatically opening and closing a floor pit in response to the presence, or absence, of a mullion. The floor pit covering system comprises a pit cover plate 1 and a pivoting system 2, as shown in Figs. 2A, 2B, 3, and 4, one such system being arranged in each floor pit 9. Most of the floor pit 9

upper part is covered by a base plate 10 which is fixed to parts of the floor adjacent to the floor pit 9, usually by bolting. The base plate 10 is provided with an opening 11 in which the pit cover plate 1 fits. Behind the base plate with respect to the pit cover plate 1 there is a removable service plate or hatch 12 which enables easy access to the pivoting system 2.

5 The pivoting system 2, which comprises an articulated link system 3 and at least one spring 4, is adapted for arranging the cover plate 1 in a first end position P1 as shown in fig. 2A or in a second end position P2 as shown in fig. 2B. By "arranging" is meant either holding the cover plate in one of the two end positions P1, P2, or moving the cover plate, in either direction, between the two end positions P1, P2, i.e., from P1 to P2 or from P2 to P1. Movement
10 is achieved in response to an internal force FI, only, or in response to an internal force FI and an external force FE which interact. The cover plate 1 is held in the first end position P1 when the external force FE is smaller than, or equal to, the internal force FI. The cover plate 1 is moved towards, and subsequently held in, the second end position P2 when the external force FE is larger than the internal force FI.

15 The first end position P1 for the cover plate 1 is a horizontal position and the second end position P2 is a vertical position. I.e., the floor pit 9 is closed by the pit cover plate 1 that extends flush with the floor in the opening 11 of the pit base plate 10 when arranged in the first end position P1, and the floor pit is open when the cover plate 1, is extending downward into the floor pit 9 and essentially perpendicular to the plane of the floor, is arranged in the second
20 end position P2.

As shown in Figs. 3, and 4, the pivoting system 2 comprises of an articulated link system 3, i.e. a spring 4 and a plurality of interconnected components, i.e. a rod 3a that is axially moveable in a horizontal plane, a swing arm 3b, a double armed crank 3c, a connection link 3d and a first and second fixed bracket 3e, 3f. The link system 3 is configured to be
25 articulated in a downward extending vertical plane in the pit 9 on horizontal axes. The cover plate 1 is arranged at a first end E1 of the articulated link system 3, and the spring 4 is arranged at a second end E2 of the articulated link system 3.

With particular reference to fig. 3 and 4, the pit cover plate 1 is realisable attached to a first end of the swing arm 3b by bolts, while the spring 4 is attached to a second end of the
30 axially movable rod 3a, also surrounding a major part of the rod 3a. The rod 3a is slidably received in a bore in a pivotable pin 13 to which the rod consequently is axially displaceable and at least slightly pivotable. The spring 4 is acting between an abutment 14 at said second end of the rod 3a and the said pin 13. The pivoting system 3 is suspended in an upper part of the floor pit 9, bolted to the underside of the pit base plate 10 via the first and second bracket
35 3e and 3f as shown in fig. 4.

As mentioned here above the cover plate 1 is attached to the free first end of the swing arm 3b. A second end of the swing arm 3b is pivotally attached to the first bracket 3e.

Further, a first end of the rod 3a is pivotally attached to a first end of the crank 3c. A second end of the crank 3c is pivotally attached to a first end of the connection link 3d. The crank 3c functions as a lever between the spring 4 and the swing arm 3b for the pit cover 1 having an intermediate section pivotally attached to the first bracket 3e. A second end of the connection link 3d is pivotally attached to the first end of the swing arm 3b under the cover plate 1.

As mentioned, this pivoting system 2 is used for holding and moving the cover plate 1 between the two end positions P1, P2. During cover plate movement, the members in the link system 3 move, while the first and second brackets 3e, 3f are fixed. The axially movable rod 3a is allowed to pivot slightly at its second end during the movement of the cover plate 1. The crank 3c pivots around its intermediate section. The connection link 3d extending between the crank 3c and the swing arm 3b, pivots about both ends. The axially movable rod 3a pivot slightly about the pin 13 and moves in a horizontal direction, in a direction towards the cover plate 1 when the cover plate 1 is moved from the first end position P1 to the second end position P2. Correspondingly the axially movable rod 3a moves in a direction from the cover plate 1 when the cover plate 1 is moved from the second end position P2 to the first end position P1.

As a result of the above, the internal force FI is generated by spring 4. The spring 4 is compressed when the cover plate 1 is moved from the first end position P1 to the second end position P2 by the external force FE, and held in the second end position P2 by the very same force FE. The spring 4 is released when the cover plate 1 is moved from the second end position P2 to the first end position P1, and held in the first end position P1. The force generated by the released spring, the internal force FI, is sufficient to hold the cover plate 1 in the first end position P1. In order to hold the cover plate 1 in the second end position P2, the external force FE, generated by the pressure applied by pin 8, has to be larger than the internal force FI generated by the compressed spring 4.

As previously mentioned, the floor pit covering system is used for covering a floor pit 9. The components of the floor pit covering system are adapted to the dimensions of the actual floor pit 9. E.g., the cover plate 1 may have dimensions corresponding to the size of the mullion pin 8.

As mentioned here above the present floor pit covering system may also be provided with a service plate or a hatch 12, which can be removed such that access to the interior of the floor pit 9 and the spring 4 is allowed. This way, the spring force may be set, when mounted, by accessing the floor pit. Further, the floor pit covering system is hereby easily accessed for service.

The spring 4 surrounding the axially movable rod 3a is preferably a disc spring, and the spring force is set by means of a number of exchangeable washers or shims. The spring force is easily adjusted by changing the number of washers, shims or use of similar means.

The washers are fitted to the end of the rod 3d by means of the abutment 14 at the second end of the axially movable rod 3a. The abutment 14 is comprised of a hex nut located at the end of the axially movable rod 4a.

With reference to fig. 1 and 2A, Fig. 2B, the above described floor pit covering system
5 is operated by means of the following steps.

An internal force FI is applied onto the cover plate 1 such that the cover plate 1 is held
in a first, horizontal end position P1, closing the floor pit. The internal force FI is permanently
generated by spring 4, the spring 4 being released in the extended position when the cover
plate is held in the first end position P1. The internal force FI, generated by the extended spring,
10 is large enough to not only overcome the downwards directed force generated by the weight
of the cover plate 1 and pivoting linkage system 3, but also any downwards directed force
generated by a vehicle or an individual applying weight onto the cover plate 1.

When splitting the door opening into several smaller door openings by means of
mullions 6, an external force FE is applied onto the upper side of the cover plate 1 by the pin
15 8. This external force FE is set large enough to overcome the predetermined limit value set for
the internal force FI of the pivoting system 2. When the external force FE is larger than the
opposing internal force FI, the cover plate 1 is moved from the first horizontal end position P1
to the second vertical end position P2, opening the floor pit, holding the cover plate 1 in that
position for as long as the external force FE is larger than internal force FI, hence allowing the
20 pin 8 to enter the floor pit 9. This movement is facilitated by the pivoting linkage system 3,
which generate movement of rod 3d in a direction towards the cover plate 1, compressing the
spring 4, and retracting the pivoting system 2 to its smallest horizontal length, i.e. the smallest
possible distance between end positions E1 and E2.

When the mullion 6, and the pin 8, is removed, the external force FE is removed from
25 the cover plate 1. As a result thereof, the external force FE becomes smaller or equal to the
internal force FI, allowing the previously compressed spring 4 to release and extend. Releasing
the spring 4 generates movement of rod 3d in the direction from the cover plate, which in turn
pivots the linkage system 3, allowing the pivoting system 2 to extend to its largest horizontal
length, i.e. the largest possible distance between end positions E1 and E2, and returning the
30 cover plate 1 to the first end position P1.

CLAIMS

1. A floor pit covering system arranged to interconnect with a pivotable mullion of a vertical lifting door, comprising a cover plate (1) and a pivoting system (2),
5 said pivoting system (2) being adapted for arranging said cover plate (1) in a first end position (P1) or in a second end position (P2) in response to an internal force (FI), or an external force (FE), being applied onto said cover plate (1), said cover plate (1) being arranged in said first end position (P1) when the external force (FE) is less or equal to the internal force (i.e. $FE \leq FI$) and in said second end position (P2) when the
10 external force (FE) exceeds the internal force (FE); (i.e. $FE > FI$), wherein said first end position (P1) is a horizontal position and said second end position (P2) is a vertical position.
2. A floor pit covering system according to claim 1, wherein said pivoting system (2) comprises an articulated joint system (3) and at least one spring (4).
15
3. A floor pit covering system according to claim 2, wherein said internal force (FI) is generated by said spring (4).
4. A floor pit covering system according to claim 2-3, wherein said cover plate (1) is arranged at a first end (E1) of said articulated joint system (3), and said spring (4) is arranged at a second end (E2) of said articulated joint system (3).
20
5. A floor pit covering system according to claim 2-4, wherein said articulated joint system (3) comprises a plurality of interconnected components (3a-3e).
25
6. A floor pit covering system according to claim 2-5, wherein said spring (4) is compressed when said cover plate (1) is arranged in said second end position (P2).
7. A floor pit covering system according to any of the previous claims, wherein said floor pit (9) is closed when said cover plate (1) is arranged in said first end position (P1), and said floor pit (9) is open when said cover plate (1) is arranged in said second end position (P2).
30
8. Method of operating a floor pit covering system according to claims 1-7, comprising the steps of:
35

- 5
- a) applying an internal force (FI) onto said cover plate (1) such that said cover plate (1) is held in a first end position (P1),
 - b) applying an external force (FE) onto said cover plate (1),
 - c) moving said cover plate (1) to a second end position (P2) when the external force (FE) exceeds the internal force (FI), (i.e. $FE > FI$),
 - d) holding said cover plate (1) in said second end position (P2) as long as the external force (FE) exceeds the internal force (FI), (i.e. $FE > FI$),
 - e) removing said external force (FE) from said cover plate (1),
 - f) returning said cover plate (1) to said first end position (P1) when the
- 10 external force (FE) is less or equal to the internal force (FI), (i.e. $FE \leq FI$).

9. Method of operating a floor pit cover system according to claim 8, wherein said first end position (P1) is a horizontal position, and said second end position (P2) is a vertical position.

15

10. Method of operating a floor pit cover system according to claim 8 or 9, wherein said floor pit (9) is closed when said cover plate (1) is arranged in said first end position (P1), and said floor pit is open when said cover plate (1) is arranged in said second end position (P2).

20 -----

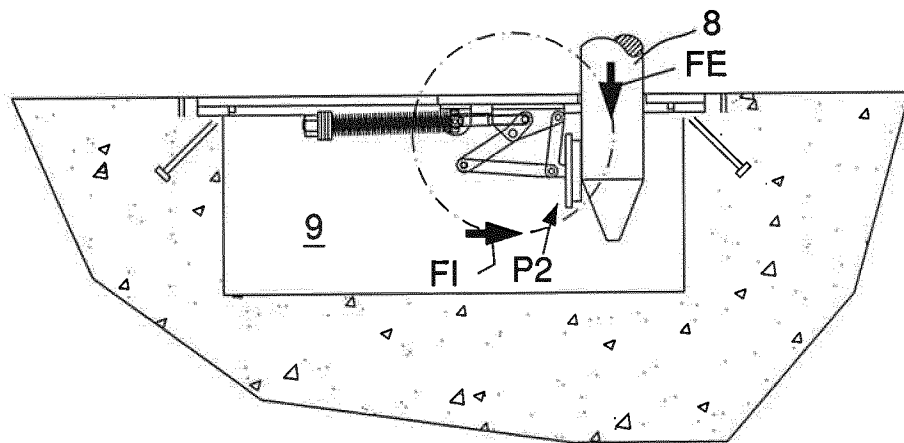
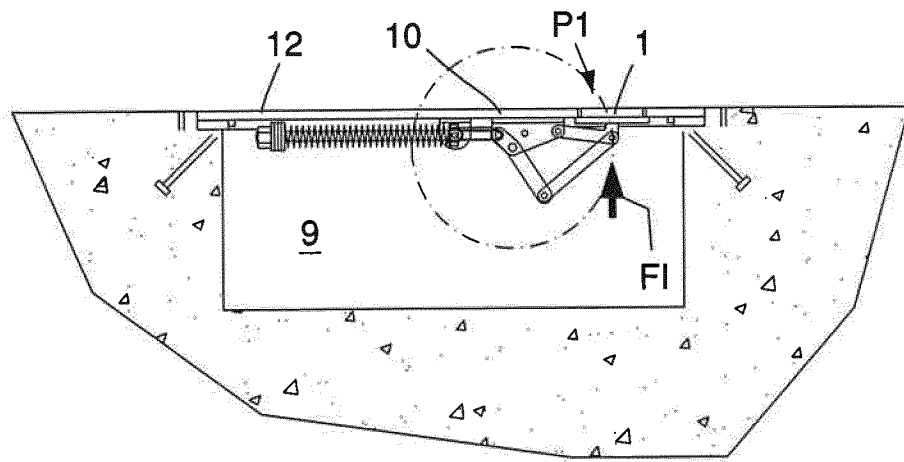
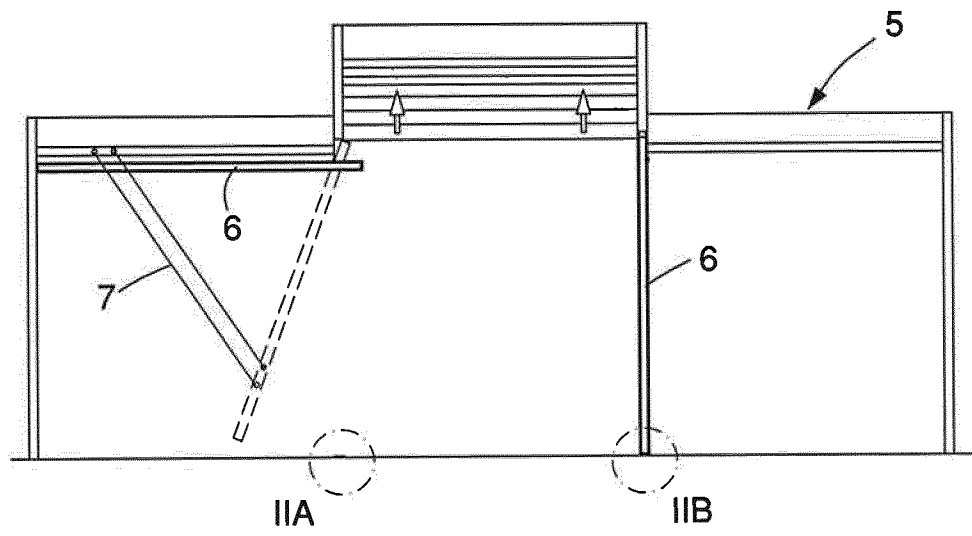

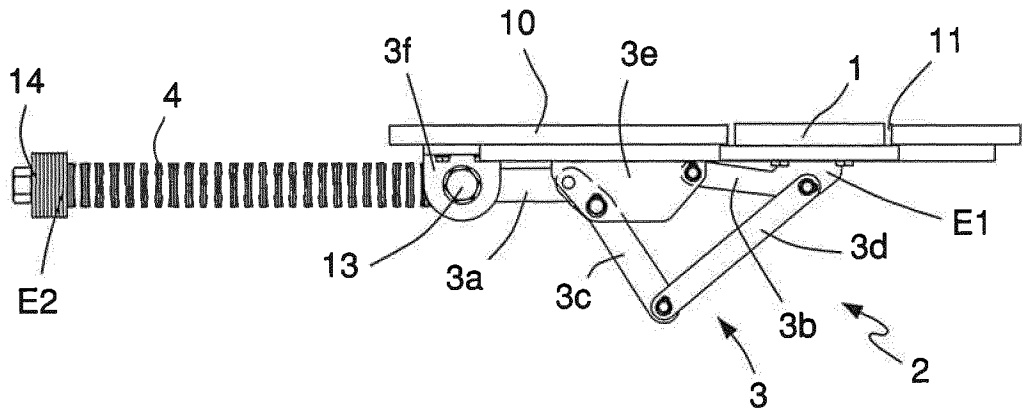

FIG.3

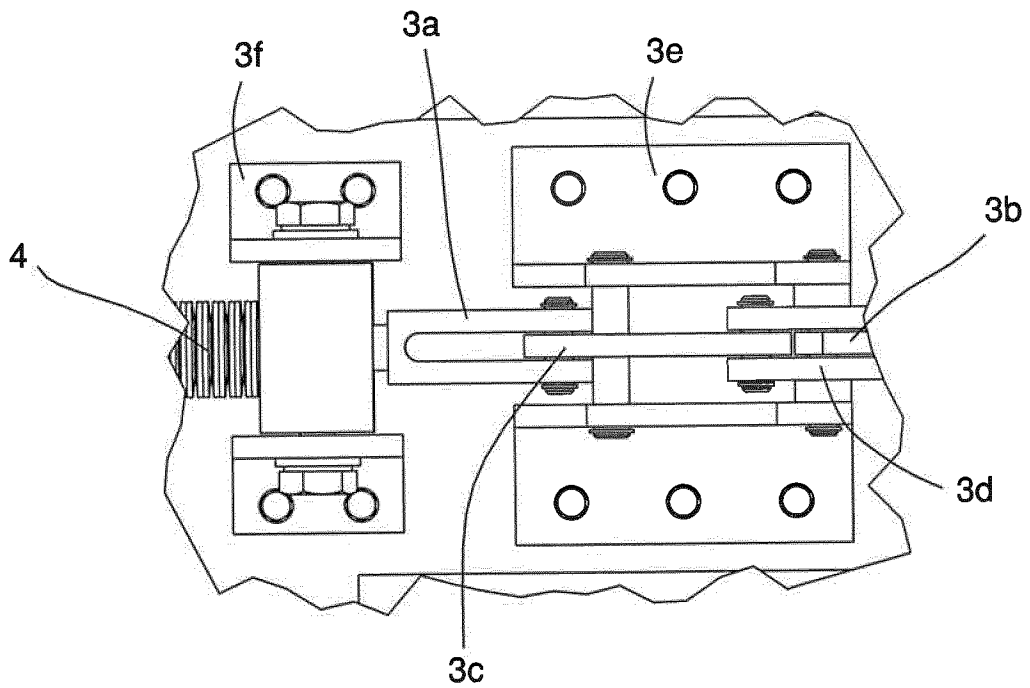

FIG.4

INTERNATIONAL SEARCH REPORT

International application No
PCT/EP2017/065718

A. CLASSIFICATION OF SUBJECT MATTER
INV. E05D15/24
ADD.
According to International Patent Classification (IPC) or to both national classification and IPC

B. FIELDS SEARCHED
Minimum documentation searched (classification system followed by classification symbols)
E05D
Documentation searched other than minimum documentation to the extent that such documents are included in the fields searched

Electronic data base consulted during the international search (name of data base and, where practicable, search terms used)
EPO-Internal

C. DOCUMENTS CONSIDERED TO BE RELEVANT

Category*	Citation of document, with indication, where appropriate, of the relevant passages	Relevant to claim No.
A	US 3 217 784 A (WOLF CECIL R ET AL) 16 November 1965 (1965-11-16) column 1 - column 2 -----	1-10

Further documents are listed in the continuation of Box C.

See patent family annex.

* Special categories of cited documents :

- "A" document defining the general state of the art which is not considered to be of particular relevance
- "E" earlier application or patent but published on or after the international filing date
- "L" document which may throw doubts on priority claim(s) or which is cited to establish the publication date of another citation or other special reason (as specified)
- "O" document referring to an oral disclosure, use, exhibition or other means
- "P" document published prior to the international filing date but later than the priority date claimed

- "T" later document published after the international filing date or priority date and not in conflict with the application but cited to understand the principle or theory underlying the invention
- "X" document of particular relevance; the claimed invention cannot be considered novel or cannot be considered to involve an inventive step when the document is taken alone
- "Y" document of particular relevance; the claimed invention cannot be considered to involve an inventive step when the document is combined with one or more other such documents, such combination being obvious to a person skilled in the art
- "&" document member of the same patent family

Date of the actual completion of the international search

29 August 2017

Date of mailing of the international search report

06/09/2017

Name and mailing address of the ISA/

European Patent Office, P.B. 5818 Patentlaan 2
NL - 2280 HV Rijswijk
Tel. (+31-70) 340-2040,
Fax: (+31-70) 340-3016

Authorized officer

Cobusneanu, D

INTERNATIONAL SEARCH REPORT

Information on patent family members

International application No

PCT/EP2017/065718

Patent document cited in search report	Publication date	Patent family member(s)	Publication date
US 3217784	A	NONE	