



(19) **United States**

(12) **Patent Application Publication** (10) **Pub. No.: US 2017/0241677 A1**

Bahar et al.

(43) **Pub. Date: Aug. 24, 2017**

(54) **FURNISHING TEMPERATURE CONTROL SYSTEM EMPLOYING AN ELECTROCHEMICAL COMPRESSOR**

Publication Classification

(71) Applicant: **Xergy Inc.**, Georgetown, DE (US)

(51) **Int. Cl.**
F25B 15/09 (2006.01)
F25B 17/12 (2006.01)
C01B 3/00 (2006.01)
B60N 2/56 (2006.01)
C09K 5/16 (2006.01)
F25B 30/04 (2006.01)
A47C 7/74 (2006.01)

(72) Inventors: **Bamdad Bahar**, Georgetown, DE (US);
William Parmelee, Seaford, DE (US)

(21) Appl. No.: **15/448,747**

(52) **U.S. Cl.**
CPC *F25B 15/09* (2013.01); *F25B 30/04* (2013.01); *F25B 17/12* (2013.01); *A47C 7/748* (2013.01); *A47C 7/744* (2013.01); *B60N 2/5678* (2013.01); *B60N 2/5692* (2013.01); *C09K 5/16* (2013.01); *C01B 3/0031* (2013.01)

(22) Filed: **Mar. 3, 2017**

Related U.S. Application Data

(63) Continuation-in-part of application No. 15/403,299, filed on Jan. 11, 2017.

(57) **ABSTRACT**

(60) Provisional application No. 62/277,399, filed on Jan. 11, 2016, provisional application No. 62/288,417, filed on Jan. 28, 2016, provisional application No. 62/292,529, filed on Feb. 8, 2016, provisional application No. 62/297,123, filed on Feb. 18, 2016, provisional application No. 62/300,082, filed on Feb. 26, 2016, provisional application No. 62/303,300, filed on Mar. 3, 2016, provisional application No. 62/308,060, filed on Mar. 14, 2016, provisional application No. 62/315,664, filed on Mar. 30, 2016, provisional application No. 62/324,337, filed on Apr. 18, 2016, provisional application No. 62/326,532, filed on Apr. 22, 2016, provisional application No. 62/303,285, filed on Mar. 3, 2016.

A heating/cooling system for furnishing employs an electrochemical heat transfer device. An electrochemical heat transfer device may be an electrochemical hydrogen compressor that pumps hydrogen into and out of a tank having a metal hydride forming alloy therein. The absorption of hydrogen by the metal hydride forming alloy is exothermic, produces heat, and the desorption of the hydrogen from the metal hydride forming alloy is endothermic and draws heat in. An electrochemical hydrogen compressor may be configured between two tanks and pump hydrogen back and forth to form a heat transfer device. A heat exchange device may be coupled with the tank or may comprise the outer surface of the tank to transfer heat to an object or to the surroundings. A closed loop may be configured having two tanks and one or two electrochemical hydrogen compressors to pump the hydrogen in a loop around the system.

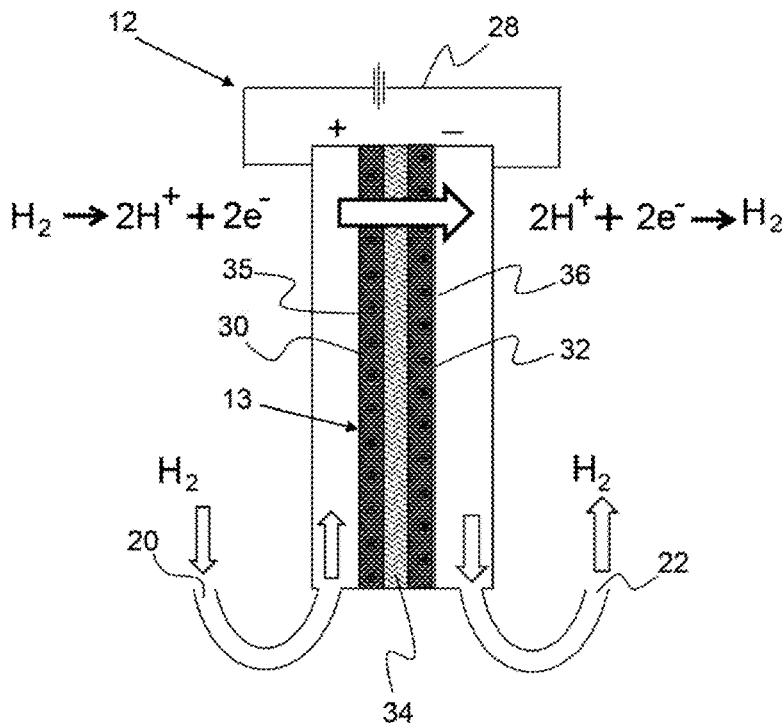

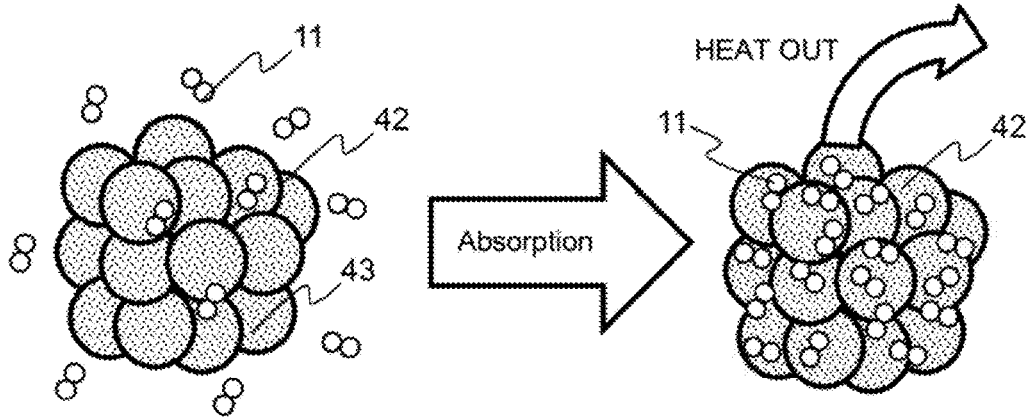

FIG. 1

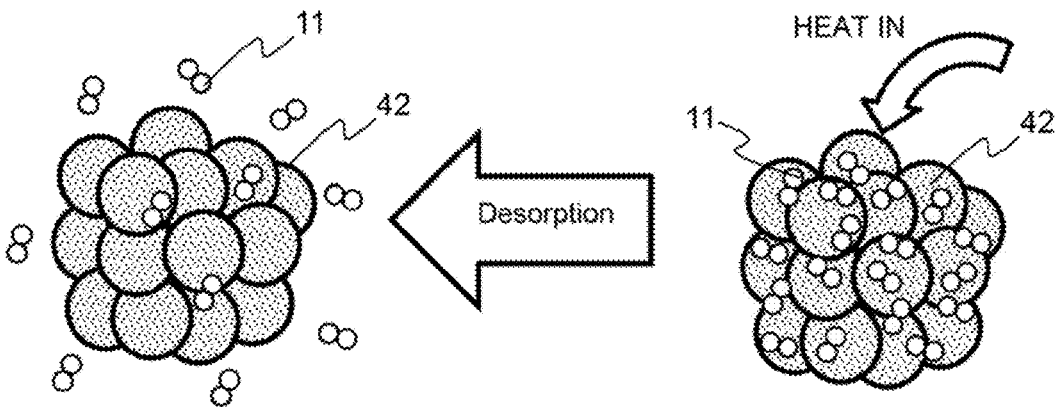

FIG. 2

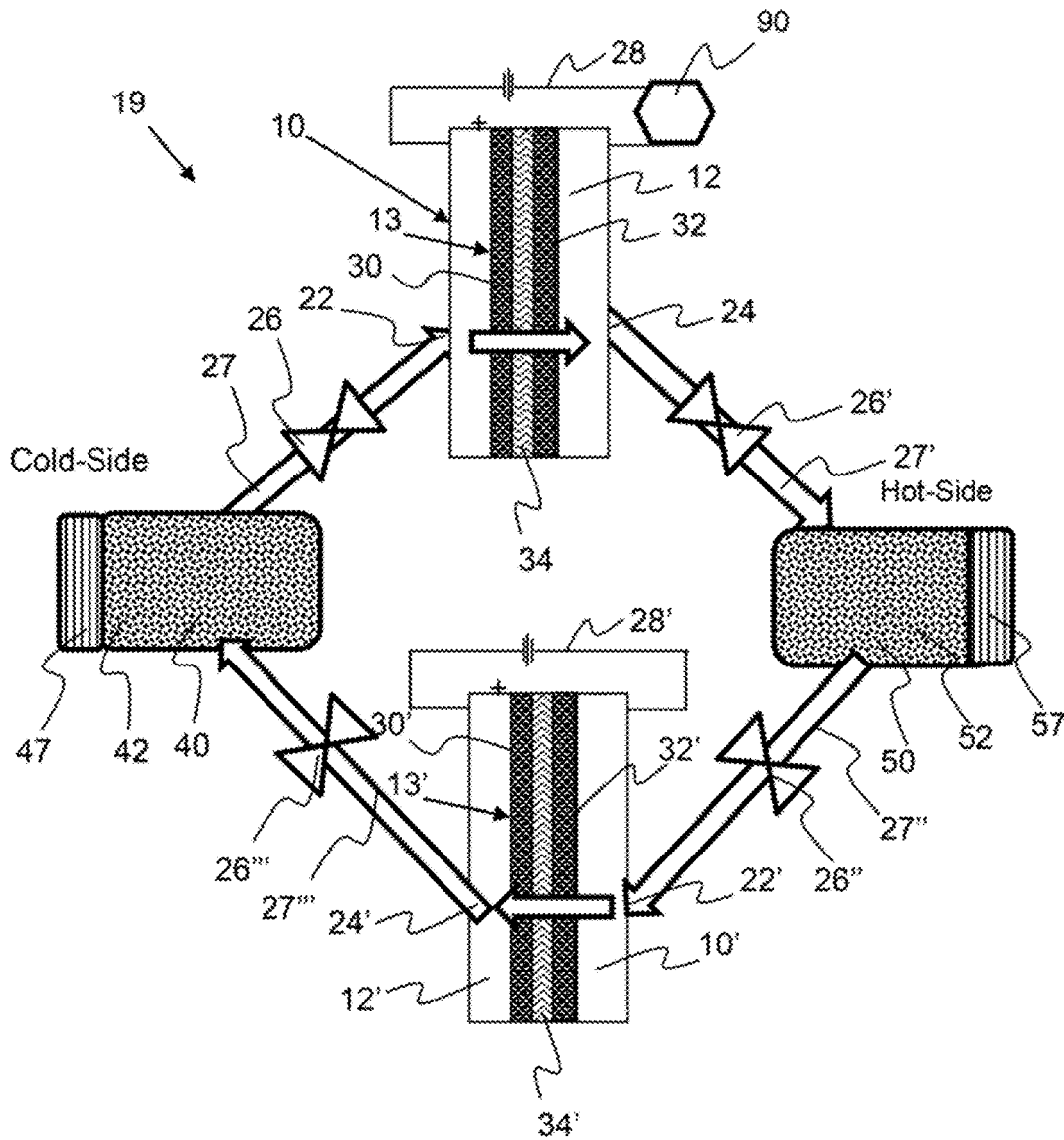

FIG. 3

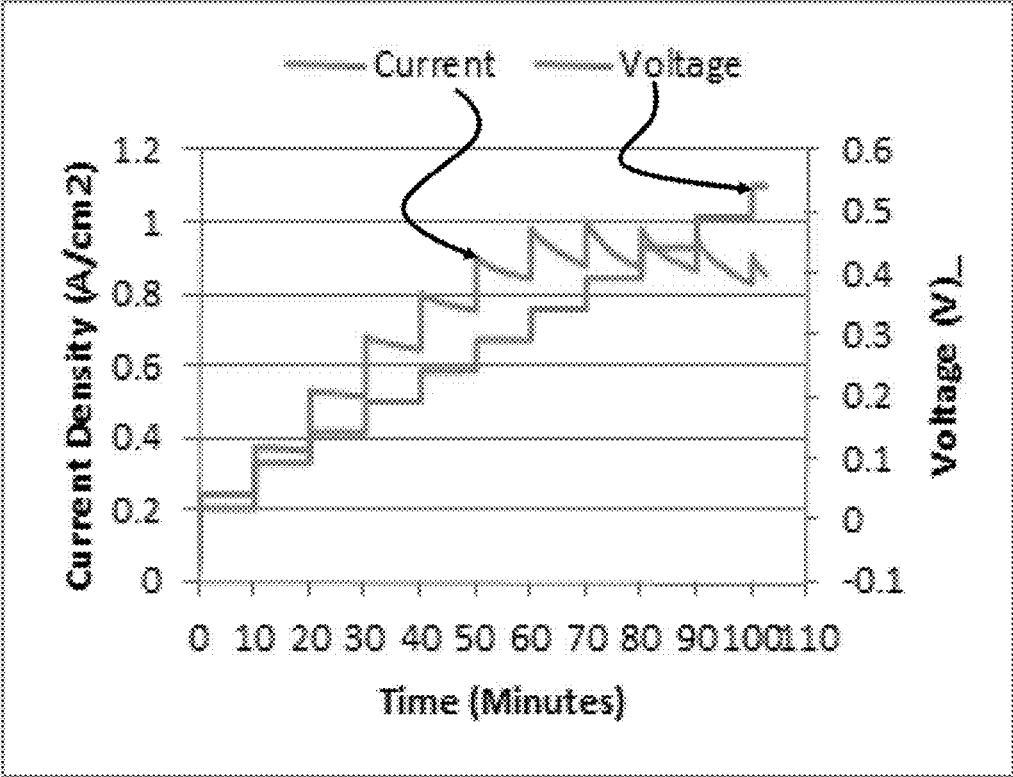
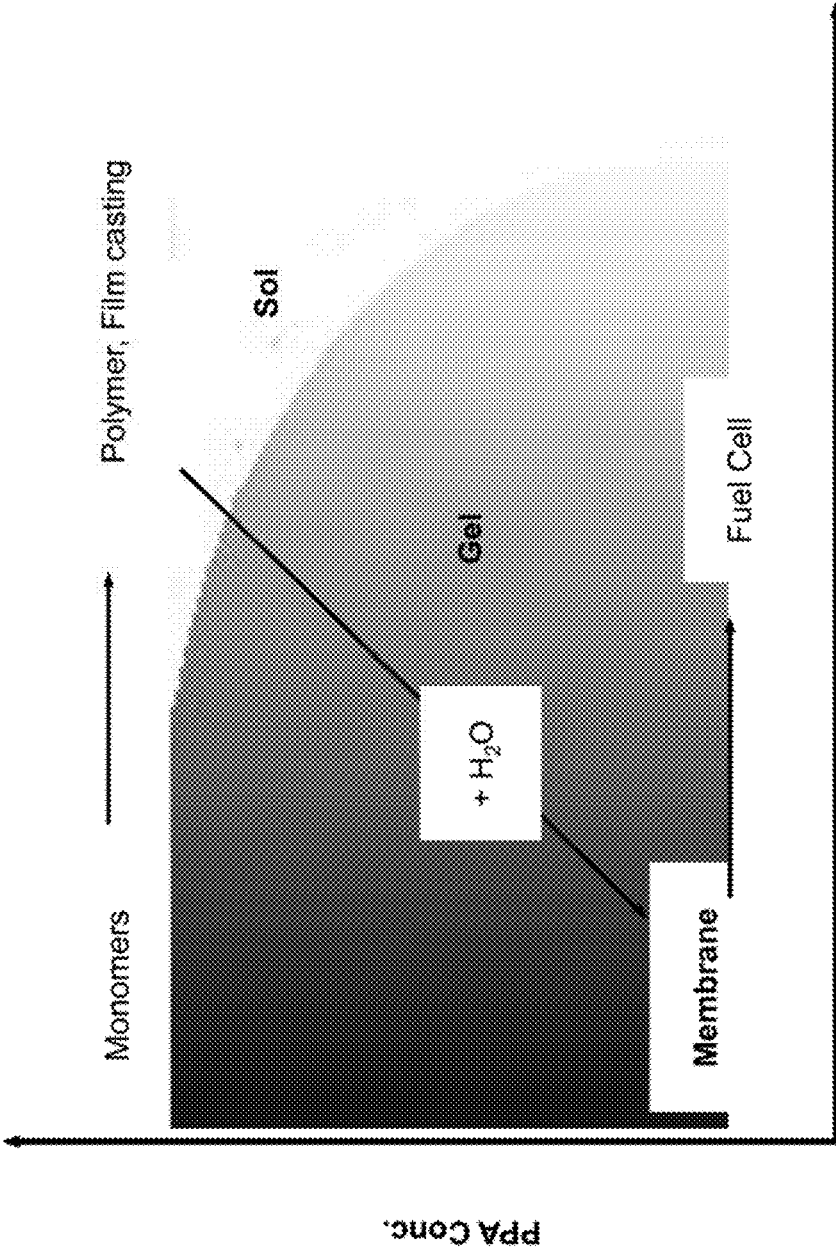

FIG. 4



Temperature
FIG. 5

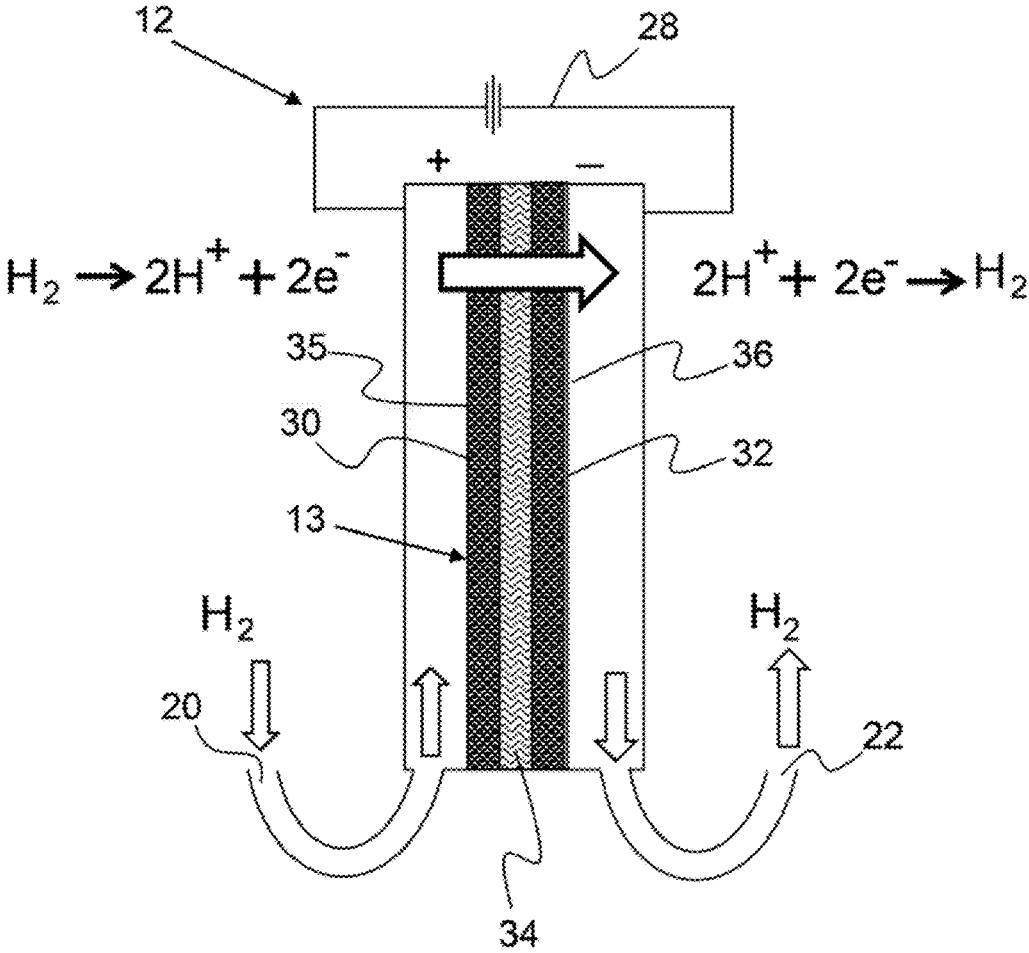

FIG. 6

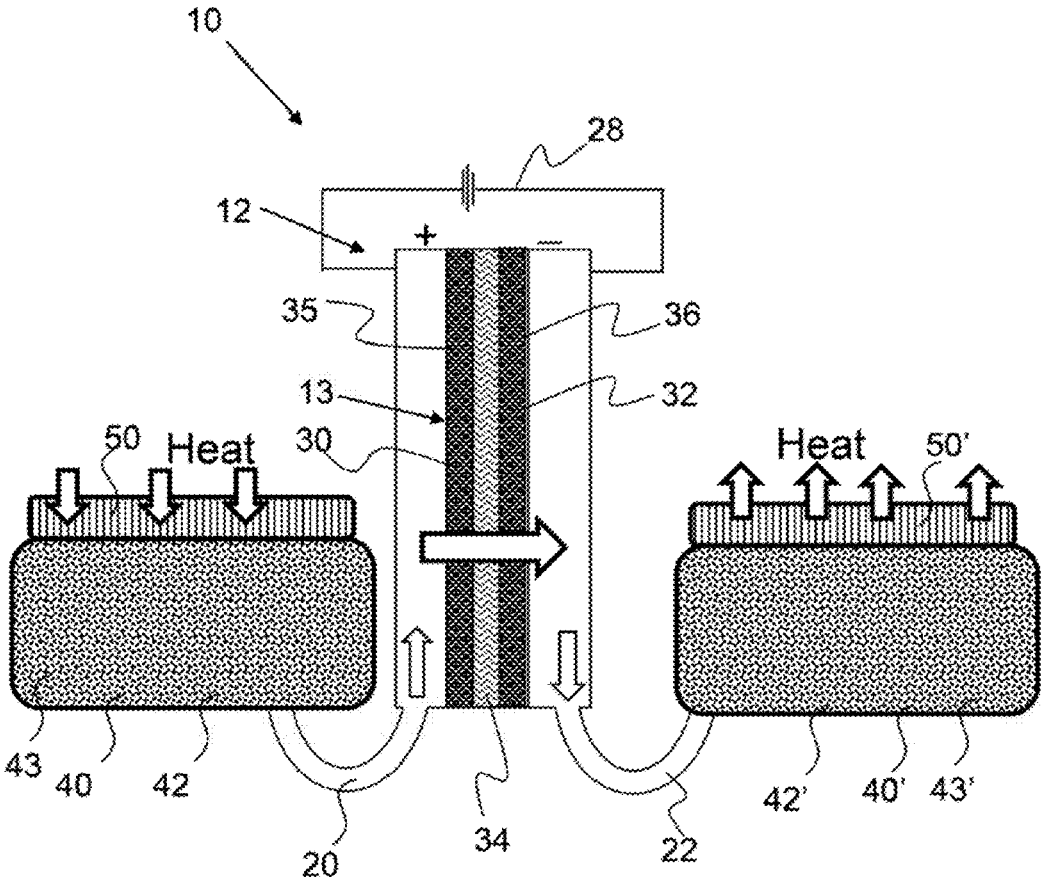
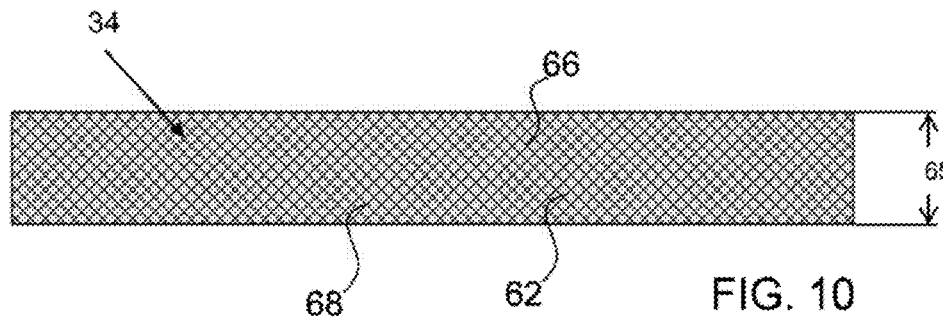
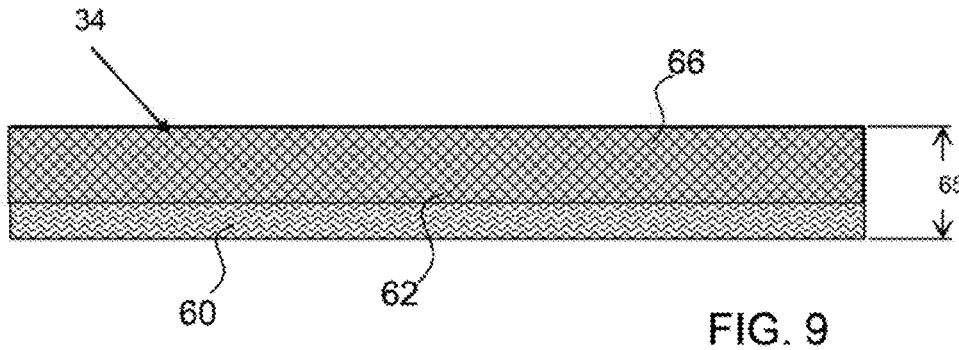
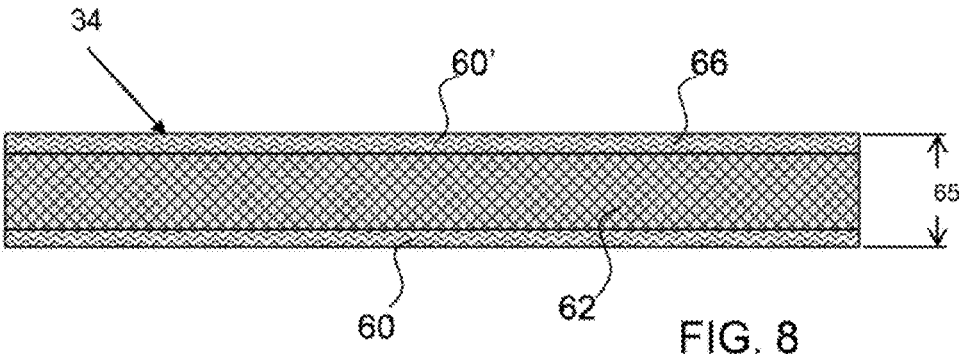

FIG. 7



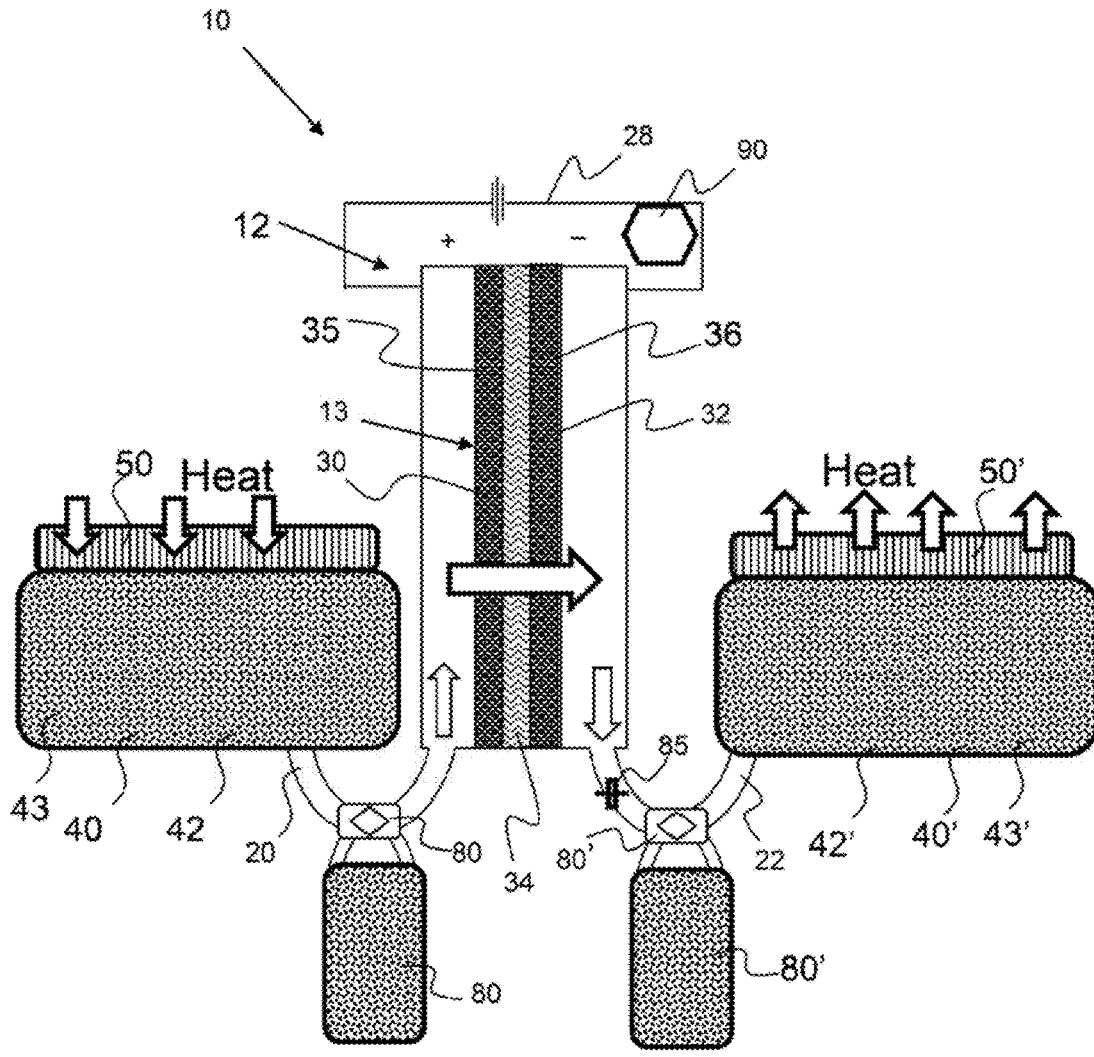

FIG. 11

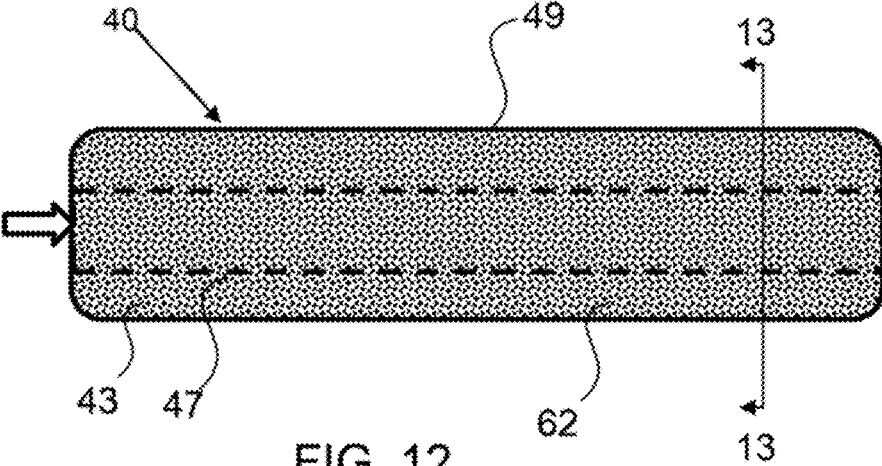

FIG. 12

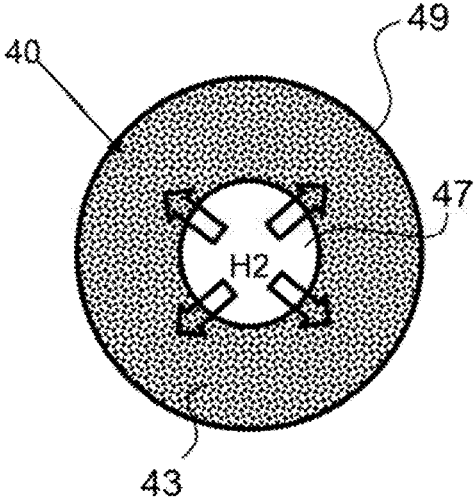

FIG. 13

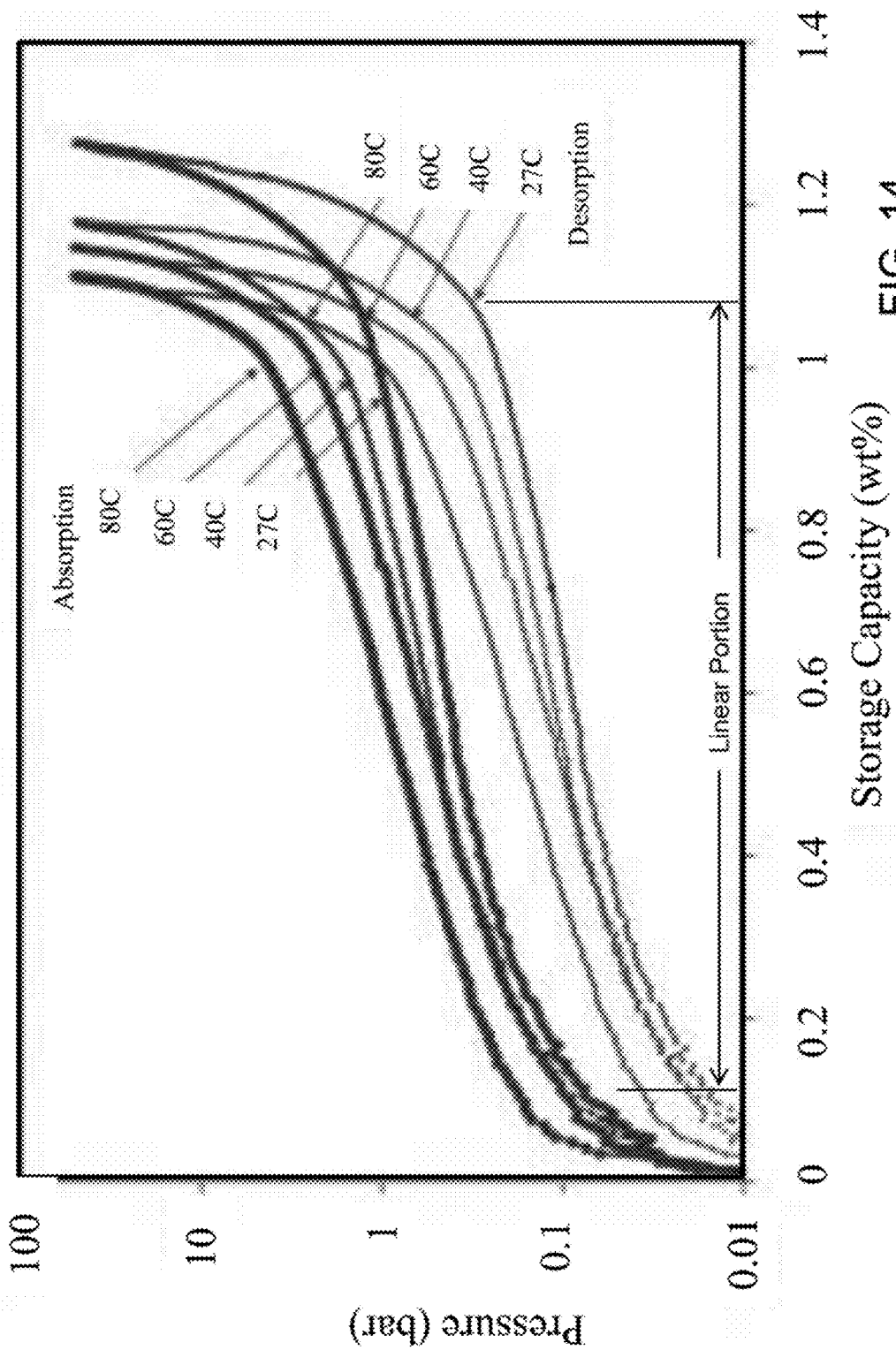

FIG. 14

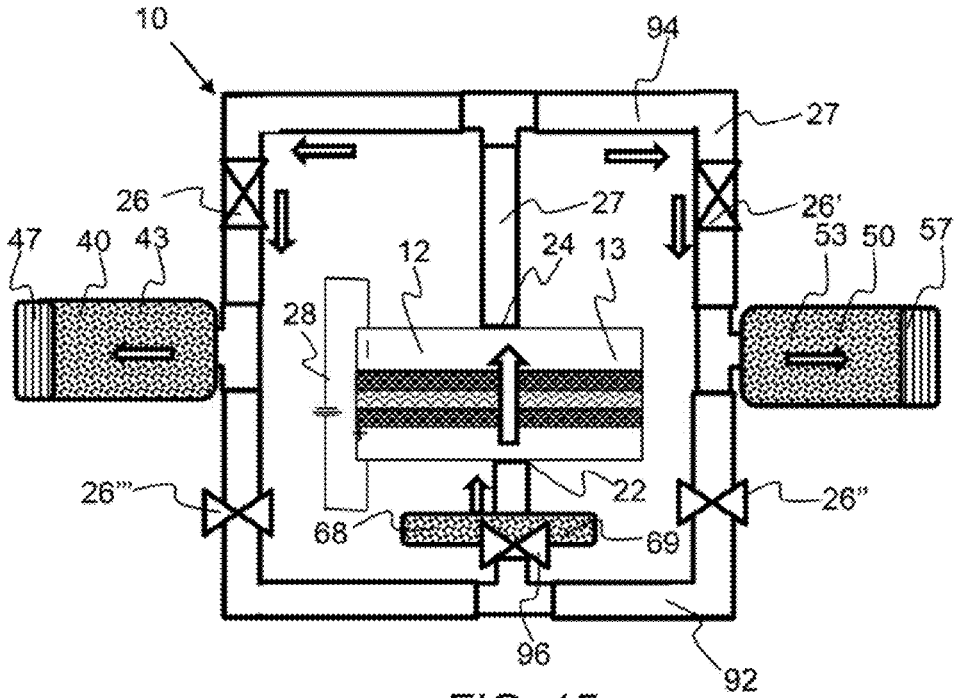

FIG. 15

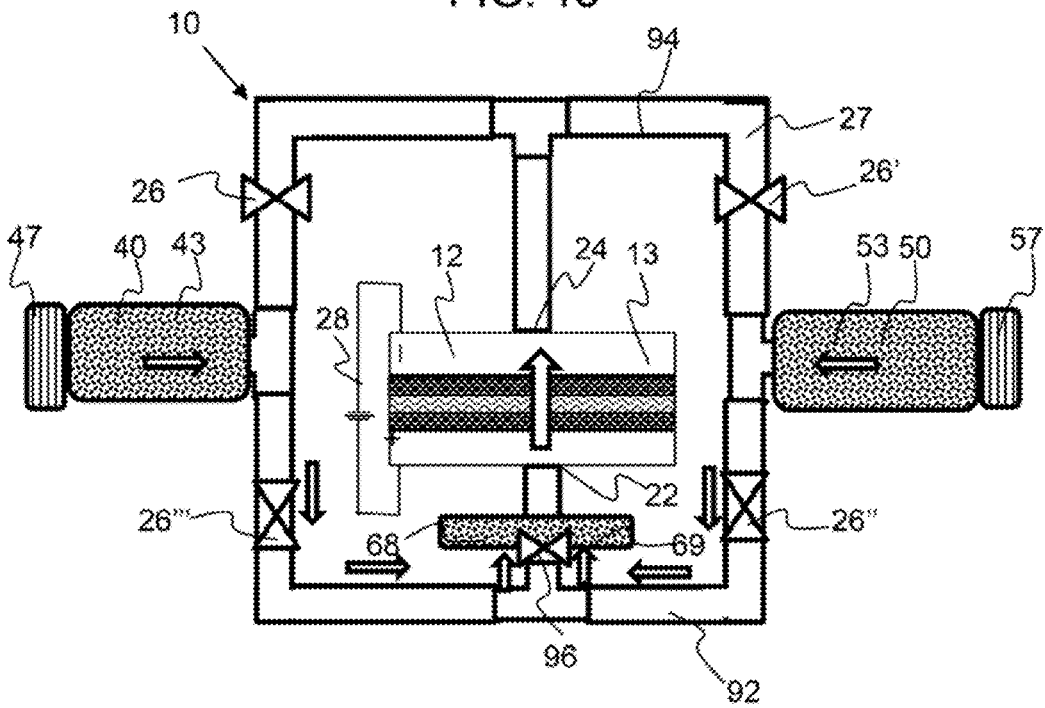

FIG. 16

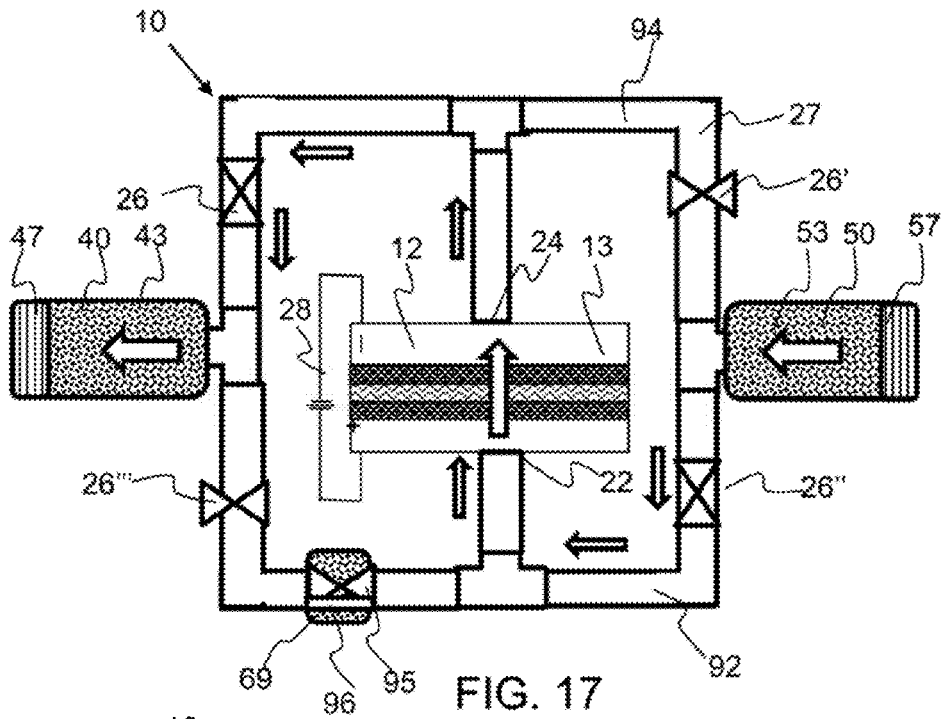

FIG. 17

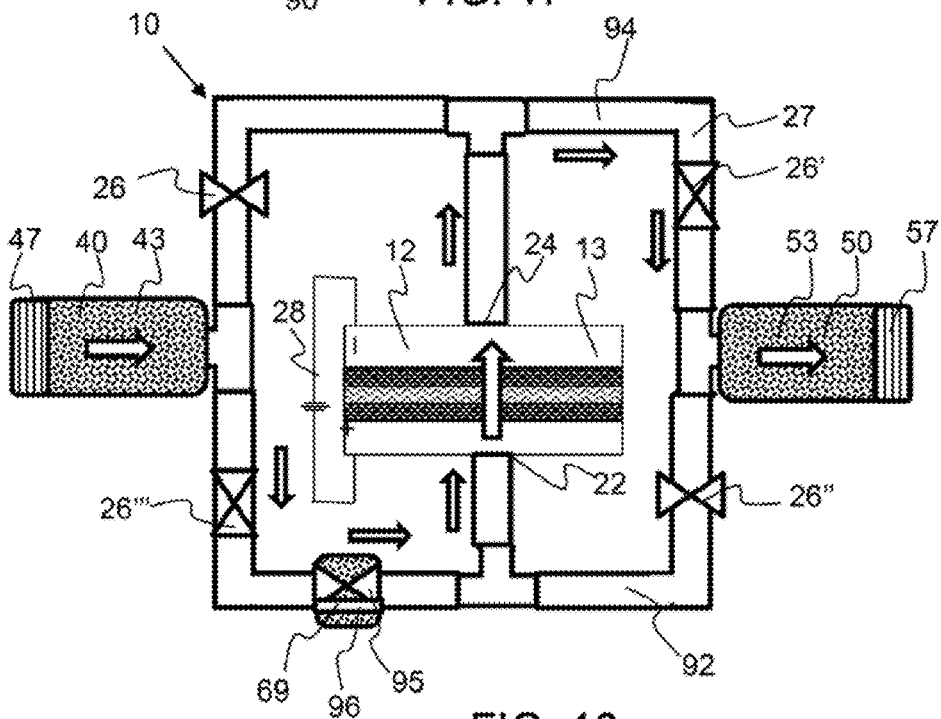

FIG. 18

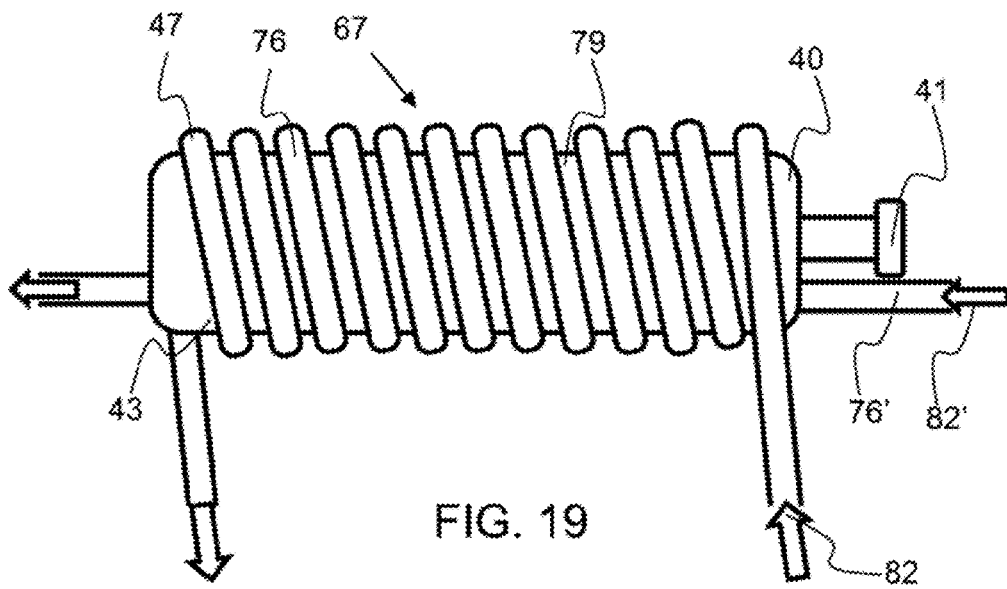

FIG. 19

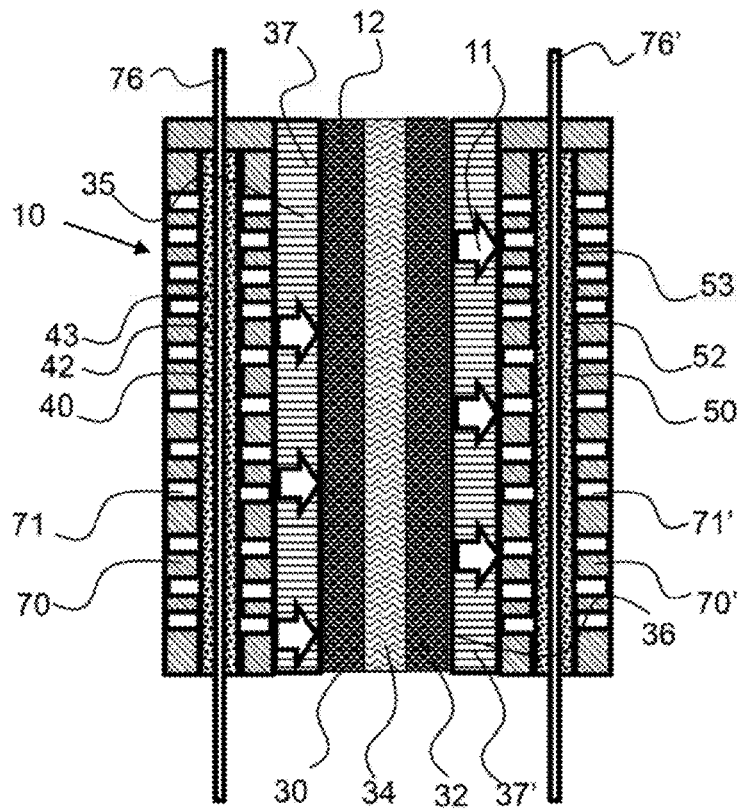

FIG. 20

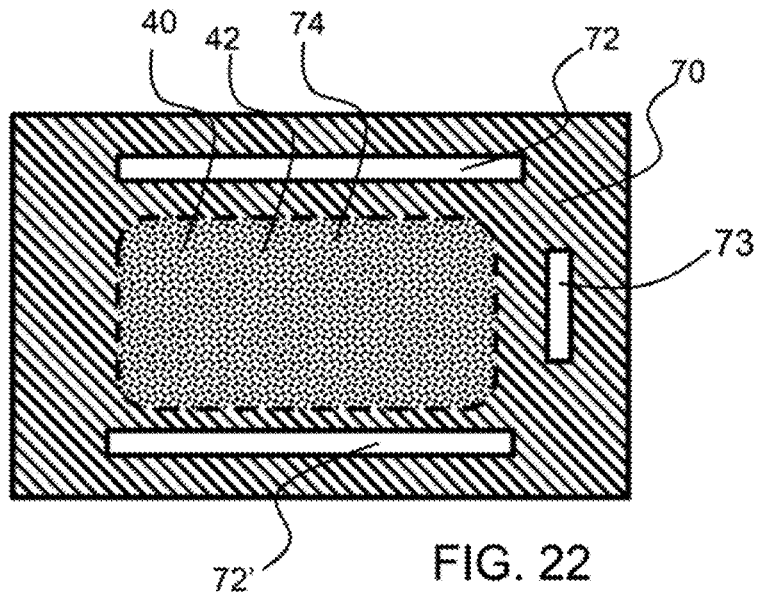

FIG. 22

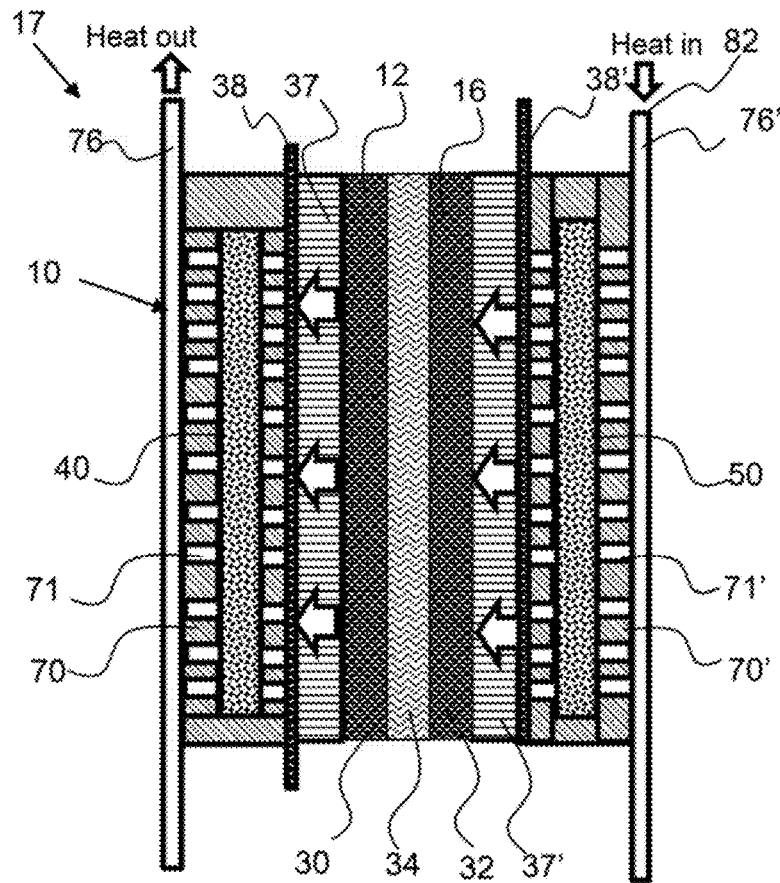

FIG. 21

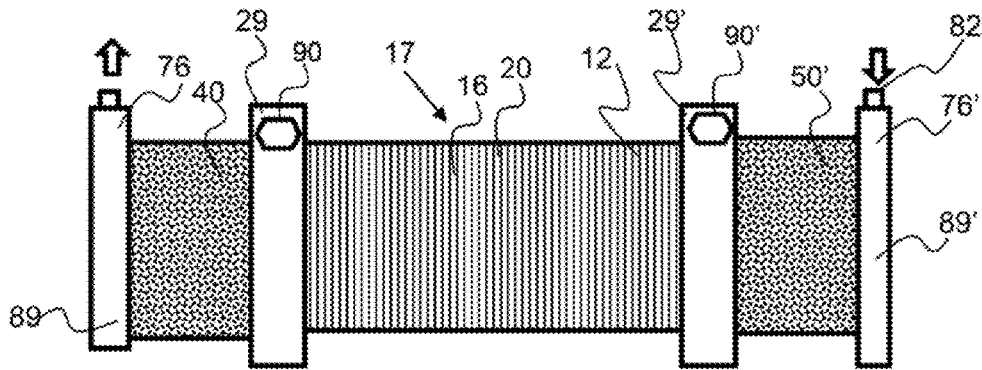

FIG. 23

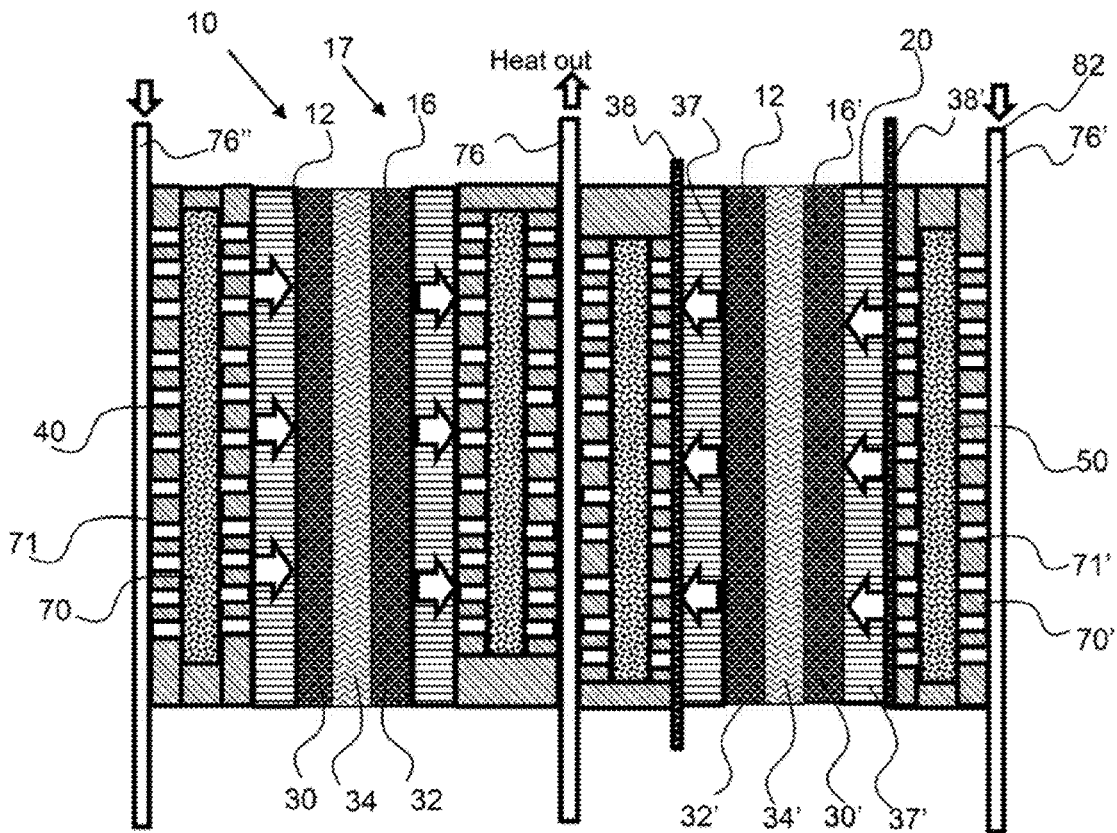
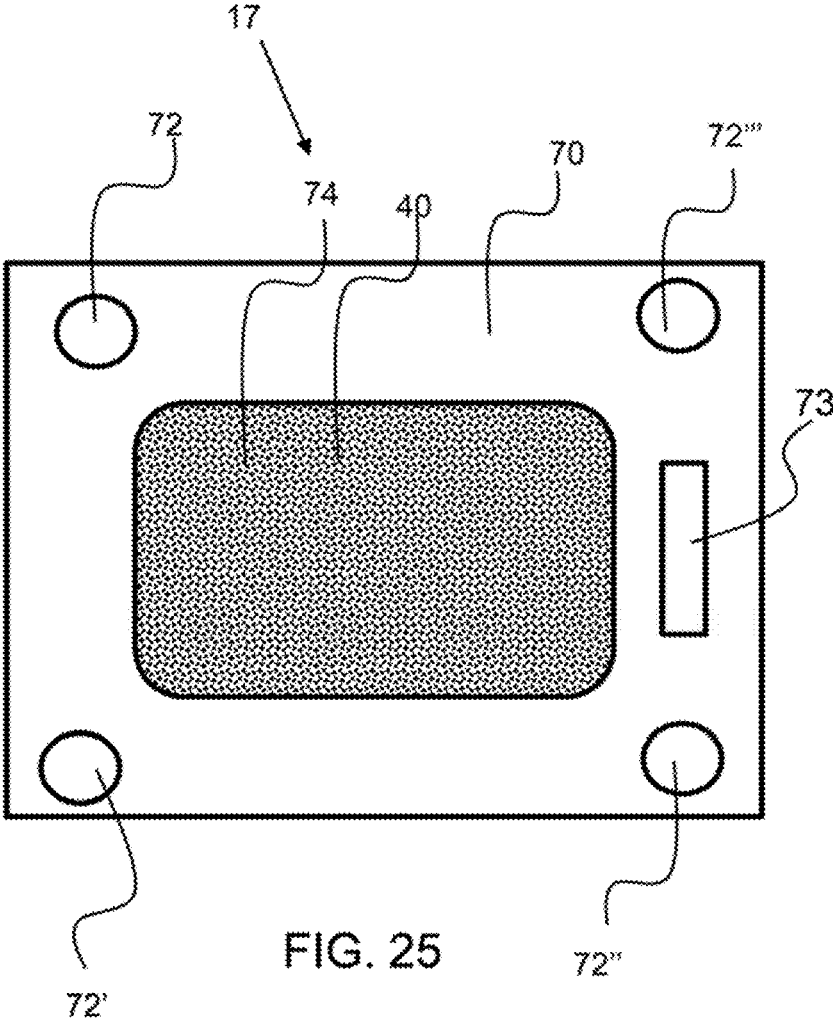

FIG. 24



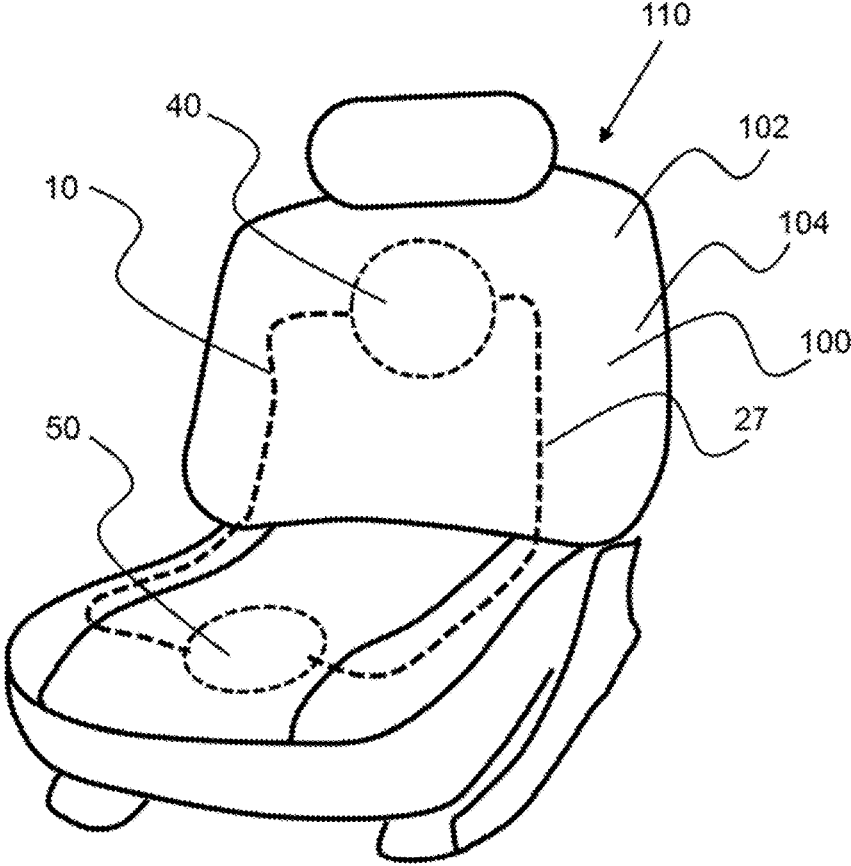

FIG. 26

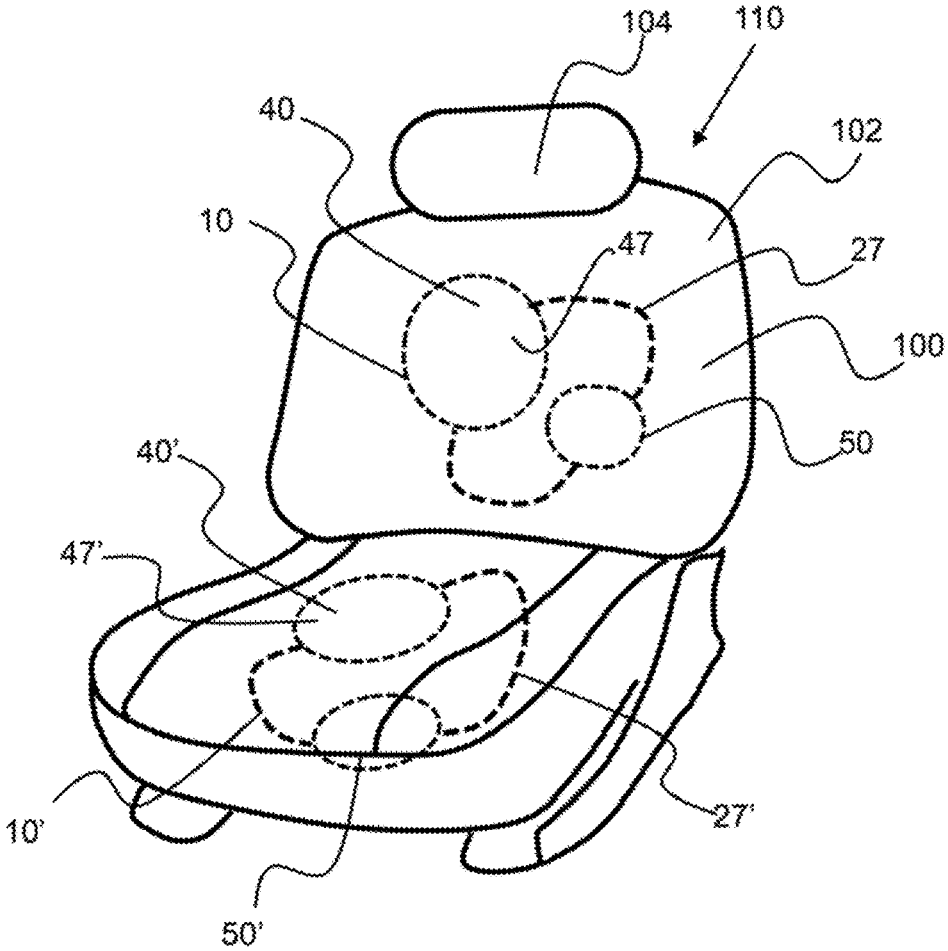

FIG. 27

**FURNISHING TEMPERATURE CONTROL
SYSTEM EMPLOYING AN
ELECTROCHEMICAL COMPRESSOR**

CROSS REFERENCE TO RELATED
APPLICATIONS

[0001] This application is a continuation in part of U.S. patent application Ser. No. 15/403,299, filed on January 11, and currently pending, which claims the benefit of priority to U.S. provisional patent application No. 62/277,399 filed on Jan. 11, 2016, U.S. provisional patent application No. 62/288,417 filed on Jan. 28, 2016, U.S. provisional patent application No. 62/292,529, filed on Feb. 8, 2016, U.S. provisional patent application No. 62/297,123, filed on Feb. 18, 2016, U.S. provisional patent application No. 62/300,082, filed on Feb. 26, 2016, U.S., and this application claims the benefit of U.S. provisional patent applications No. 62/303,300 filed on Mar. 3, 2016, U.S. provisional patent application No. 62/308,060 filed on Mar. 14, 2016, U.S. provisional patent application No. 62/315,664 filed on Mar. 30, 2016, U.S. provisional patent application No. 62/324,337 filed on Apr. 18, 2016, and U.S. provisional patent application No. 62/326,532 filed on Apr. 22, 2016, and U.S. provisional patent application No. 62/303,285, filed on Mar. 3, 2016; the entirety of each reference listed above is hereby incorporated by reference herein.

BACKGROUND OF THE INVENTION

[0002] Field of the Invention

[0003] This invention relates to a heating/cooling system for furnishings, and more specifically, to human contact furnishings including beds, chairs, couches, seats including vehicles seats. A vehicle seat includes seats in motor vehicles such as cars, trucks, busses and the like and also includes airplane seats, train seats, water craft seats, motor-cycle seats, bicycle seats and the like.

[0004] Background

[0005] The function of heat pumps is to remove heat from a heat source or reservoir at low temperature and to reject the heat to a heat sink or reservoir at high temperature. While many thermodynamic effects have been exploited in the development of heat pumps and refrigeration cycles, one of the most popular today is the vapor compression approach. This approach is sometimes called mechanical refrigeration because a mechanical compressor is used in the cycle. Any improvement in efficiency related to compressor performance can have significant benefits in terms of energy savings and thus have significant positive environmental impact.

[0006] Vapor compression heat pump cycles generally contain five important components. The first is a mechanical compressor that is used to pressurize a gaseous working fluid. After proceeding through the compressor, the hot pressurized working fluid is condensed in a condenser. The latent heat of vaporization of the working fluid is given up to a high temperature reservoir, often called the sink. The liquefied working fluid is then expanded at substantially constant enthalpy in a thermal expansion valve or orifice. The cooled liquid working fluid is then passed through an evaporator. In the evaporator, the working fluid absorbs its latent heat of vaporization from a low temperature reservoir often called a source. The last element in the vapor compression refrigeration cycle is the working fluid itself.

[0007] In conventional vapor compression cycles, the working fluid selection is based on the properties of the fluid and the temperatures of the heat source and sink. The factors in the selection include the specific heat of the working fluid, its latent heat of vaporization, its specific volume, and its safety. The selection of the working fluid affects the coefficient of performance of the cycle. In an electrochemical compressor the electrochemical characteristics of a potential working fluid is important. Fluids can be selected for active or passive participation in the compression system. An active material is driven through the compressor in a reversible redox reaction whereas passive working fluids are moved through the compressor by association with the electroactive species, in most cases Hz.

[0008] For a refrigeration cycle operating between a lower limit, or source temperature, and an upper limit, or sink temperature, the maximum efficiency of the cycle is limited to the Carnot efficiency. The efficiency of a refrigeration cycle is generally defined by its coefficient of performance, which is the quotient of the heat absorbed from the sink divided by the net work input required by the cycle.

[0009] Any improvement in heat pump systems clearly would have substantial value. Electrochemical energy conversion is considered to be inherently better than other systems due to their relatively high exergetic efficiency. In addition, electrochemical systems are considered to be noiseless, modular, and scalable and can provide a long list of other benefits depending on the specific thermal transfer application.

[0010] Dry sorption systems based on metal hydrides to provide heating and cooling, metal hydride heating and cooling systems (MHHCS), are known. The coefficient of performance of most single stage MHHCS systems have been below 0.5 through the 1990's. A decade or so later, coefficient of performance as high as 1.5 has been reported. Most recently, coefficient of performance above 2.5 or better has been shown which can be better than conventional vapor compression systems. A major challenge in the development or application of the MHHCS units has been the development and availability of low capacity (dry) hydrogen compressors that can operate efficiently.

[0011] A traditional problem with mating electrochemical compressors to metal MHHCS units has been the need to provide dry hydrogen to the metal hydride units. Metal Hydrides are very sensitive to hydrolysis and any amount of moisture in the hydrogen gas will accelerates the aging of these compounds. In addition, the materials used for storing the hydrides are generally made from low alloy steels that are sensitive to aqueous corrosion as well as to hydrogen embrittlement, and the interactions between these two types of damage caused by the presence of moisture is a significant concern.

[0012] Electrochemical systems typically require water for proton mobility and therefore provide a humidified hydrogen stream to the electrochemical compressor. Coupling an electrochemical compressor with a drying operation adds complexity and parasitic energy to the system, and increases both the overall cost of the system and operational costs.

[0013] Metal hydride heat pumps as well as electrochemical compressors are known devices with unique features and benefits. However, mating the two units for proper operation for appliances is non-trivial. There are numerous, sometimes subtle, often non-obvious elements that must be incorpo-

rated into systems to enable long-term, safe operation of an electrochemical compressor driven metal hydride heat pump.

[0014] Therefore, there is a need for a low cost system and method to operate a metal hydride heat pump at low humidity levels

[0015] Temperature modified air for environmental control of living or working space is typically provided to relatively extensive areas, such as entire buildings, selected offices, or suites of rooms within a building. In the case of vehicles, such as automobiles, the entire vehicle is typically cooled or heated as a unit. There are many situations, however, in which more selective or restrictive air temperature modification is desirable. For example, it is often desirable to provide an individualized climate control for an occupant seat so that substantially instantaneous heating or cooling can be achieved. For example, an automotive vehicle exposed to the summer weather, where the vehicle has been parked in an unshaded area for a long period, can cause the vehicle seat to be very hot and uncomfortable for the occupant for some time after entering and using the vehicle, even with normal air conditioning. Furthermore, even with normal air-conditioning, on a hot day, the occupants back and other pressure points may remain sweaty while seated. In the winter, it is highly desirable to have the ability to warm the seat of the occupant quickly to facilitate the occupant's comfort, especially where the normal vehicle heater is unlikely to warm the vehicle's interior as quickly.

[0016] For such reasons, there have been various types of individualized temperature control systems for vehicle seats. Such temperature control systems typically include a distribution system comprising a combination of channels and passages formed in the back and/or seat cushions of the seat. A thermal module thermally conditions the air and delivers the conditioned air to the channels and passages. The conditioned air flows through the channels and passages to cool or heat the space adjacent the surface of the vehicle seat.

[0017] There are, however, drawbacks with existing temperature control systems for seats. For example, in particularly adverse conditions, it may take the conditioned air a long period of time to heat noticeably the seat. In addition, while climate control systems that use thermal modules provide many advantages, they are relatively expensive and thus may not be suitable for all applications.

[0018] In addition, current systems employ thermoelectric (peltier) systems that use exotic materials. For many years, the main three semiconductors known to have both low thermal conductivity and high power factor were bismuth telluride (Bi_2Te_3), lead telluride (PbTe), and silicon germanium (SiGe). These materials have very rare elements which make them very expensive compounds.

[0019] In addition, current systems employing thermoelectric (peltier) systems exhibit very poor coefficients of performance (COP); typically under 1. This inefficiency is a significant drawback.

[0020] As seat heating applications increase to literally millions of units, both the poor performance, and raw material supply issues make addressing this problem a critical issue. Thus, there is a need for an improved temperature control apparatus for a climate control system for seats.

SUMMARY OF THE INVENTION

[0021] The present invention is directed to a heating system employing an electrochemical heating device for controlling the temperature of furnishing and more specifically to human contact furnishings including beds, chairs, couches, love seats, benches seats, vehicle seats, such as seats in a vehicle including cars. Vehicle seats may include seats in motor vehicles such as cars, trucks, busses and the like, as well as train seats, airplane seats, water craft seats, motorcycle seats, bicycle seats and the like.

[0022] Electrochemical Compressors are known to be able to heat and cool by employing various refrigeration cycles such as water vapor compression and/or absorption/desorption of hydrogen in metal hydride heat exchangers. A unitary construction of an electrochemical compressor with other components into a unitary heating and/or cooling device is useful for a number of different applications as a unitary heating or cooling element.

[0023] Accordingly, one aspect of the present invention comprises a method for thermally conditioning a space adjacent a seat assembly that includes activating a heating element positioned within the seat assembly beneath a seat covering. A fluid module that includes a fluid supply device and an electrochemical compressor based heating (and or cooling) element is activated to direct heated air from the fluid module to a space adjacent the seat assembly through a distribution system formed at least partially in the seat cushion. After a period of time, the heating element is deactivated.

[0024] Another aspect of the present invention comprises a climate controlled seat assembly that includes a seat cushion having an outer surface. A supply passage extends through the seat cushion and includes an inlet. A distribution system comprises at least one distribution passage configured to distribute air along the support surface of the seat cushion. The distribution system communicates with the supply passage. A seat covering is positioned over the outer surface of the seat cushion. A heat source is positioned between the seat covering and the inlet to the supply passage. A fluid module is operatively connected to the inlet of the supply passage. The fluid module includes a fluid transfer device configured to move air between the distribution system and the supply passage and a thermoelectric device configured to heat air moving the fluid module. A control system is configured to activate, upon receiving an input signal generated by a user, the fluid module to provide heated air to the outer surface of the seat cushion and to activate the heat source for a predetermined period of time.

[0025] Another aspect of the present invention comprises a seat cushion having a front or top side configured to support an occupant and a generally opposing rear or bottom side. Fluids passages extend through from rear or bottom side of the seat cushion to the front or top side of the seat cushion. A fluid module includes a fluid device configured to move fluid within the fluid passages and a thermal element configured only to cool fluid moved by the fluid device. A restive heater is disposed on the front or top side of the seat cushion.

[0026] Another aspect of the present invention comprises a method for thermally conditioning a space adjacent a seat assembly that includes a seat cushion that defines a support surface and seat covering that covers the support surface of the seat cushion. The method comprises, during a heating mode, activating a heating element positioned within the

seat assembly to heat the space adjacent the seat assembly. During a cooling mode, cooled air is directed from a fluid module that includes a thermoelectric unit and a fluid transfer device to the space adjacent the seat assembly through a distribution system formed at least partially in the seat cushion to cool the space adjacent the seat assembly.

[0027] Another aspect of the present invention relates to a method for thermally conditioning a space adjacent a seat assembly that includes a seat cushion that defines a support surface and seat covering that covers the support surface of the seat cushion. The method comprises, during a first mode, directing heated air from a fluid module that includes an electrochemical compressor unit and a fluid transfer device to the space adjacent the seat assembly through a distribution system formed at least partially in the seat cushion to heat the space adjacent the seat assembly. During a second mode, a heating element positioned within the seat assembly between the seat covering and the fluid module is activated while directing heated air from the fluid module through the distribution system to heat the space adjacent the seat assembly.

[0028] In another aspect, a thermostat controlled mattress includes a mattress unit having an underlay, a surface cover and a curved circuit. A water circuit tube connects to the curved circuit so as to allow water to be introduced into the mattress unit with the aid of a pump. Water is circulated between the mattress unit and a water storage box via the water circuit tube. A sensor is operatively arranged with respect to the water storage box to sense the temperature and quantity of water contained in the water storage box and sends a signal to a thermostat electric circuit. An aluminum reservoir for the water is connected to the curved circuit of the mattress unit and the water circuit tube. An electrochemical compressor based heating or cooling element is connected to the reservoir and the power supply to heat or cool the water. Water is circulated in the water circuit tube between the curved circuit of the mattress unit and the water storage box, through the reservoir. The water temperature is controlled based on signals generated by the thermostat electric circuit, which activates the power supply operatively connected to the heating and/or cooling element. A heat sink and a fan may be arranged adjacent to the heating and/or cooling element such that the fan blows a current of air onto the heat sink.

[0029] Similar concepts are feasible for airplane seats, pet maintenance housings and other devices that require controlled thermal systems for an underlayment.

[0030] Further features and advantages of the present invention will become apparent to those of ordinary skill in the art in view of the detailed description of preferred embodiments which follow, when considered together with the attached drawings and claims.

[0031] In an exemplary embodiment, the temperature control system for furnishings utilizes an electrochemical compressor-driven metal hydride heat pump system. In an exemplary embodiment, the metal hydride heat pump utilizes a dry hydrogen gas without excessive parasitic loads, such as from a condenser. One advantage of these systems is the elimination of Freon and other refrigerants that are a major environmental concern. Another advantage is the noiseless, and vibration free operation of the systems. Finally, without the parasitic load of desiccation systems for the hydrogen

gas, the systems provide very high efficiencies (i.e. high coefficients of performance), for many important applications.

[0032] The heat pump system utilizes the highly exothermic absorption of hydrogen gas into a hydride-forming metal alloy or intermetallic compound. Metal hydride (MH) formation is highly reversible, and the endothermic desorption of hydrogen from the metal hydride matrix requires a heat supply approximately equal to the heat released during hydrogen absorption. Both of these processes are represented by the reaction.

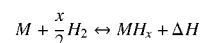

[0033] where M represents the hydride-forming metal of choice.

[0034] In an exemplary embodiment, the device or system of the present invention comprises at least one electrochemical compressor (ECC) to transfer pressurized hydrogen between two packed beds of metal hydride material as shown schematically in FIG. 2. The heat and cold released by the metal hydride bed during the adsorption/desorption process will be extracted by a working fluid circulating through a heat exchanger to transfer heat between the exothermic metal hydride reactor. Coupling an electrochemical compressor with metal hydride packed bed reactors summarily represents a solid-state heating technology with no moving parts and without the thermodynamic irreversibility associated with conventional vapor compression cycles, thereby enabling operational efficiencies beyond Carnot cycle limitations. The only irreversibility associated with the electrochemical compressor and metal hydride packed bed system arises from the entropy produced in their respective undergirding electrochemical (hydrogen oxidation/reduction) and chemical (hydrogen absorption/desorption) reactions, thus allowing gains in efficiency that are unachievable with purely mechanical heating cycles.

[0035] The system of the present invention overcomes limitations inherent to previous compressor-driven metal hydride heat pumps concepts that engaged per-fluorinated sulfonic acid (PFSA) proton exchange membrane (PEM) design requiring alternating desiccation/rehydration of the Hydrogen stream and flow circuit design^{1,2,3,4}. The electrochemical compressor operates through electrocatalytic oxidation of hydrogen at the anode side of a proton exchange membrane at low pressure, reduction of protons on the cathode side of the membrane to yield hydrogen at high pressure. PFSA membranes must remain well hydrated in order to maintain proton conductivity, and are also restricted to operating temperatures to below 80° C. Consequently, the hydrated hydrogen stream exiting the compressor must be desiccated (inherently non-continuous; and parasitic) since water vapor will denature the metal hydride bed by transforming it to a metal hydroxide.

[0036] In an exemplary embodiment, the electrochemical compressor utilizes a novel phosphoric acid-functionalized polybenzimidazole/polytetrafluoroethylene (PBI/PTFE) composite membrane which has demonstrated markedly improved thermal and mechanical stability over conventional per-fluorinated sulfonic acid PEMs at higher temperatures (100-200° C.) while maintaining acceptable proton conductivity. The use of ultra-thin, composite membranes

for use in electrochemical devices, such as electrochemical compressors, is taught in pending U.S. patent application Ser. No. 13/943,619, to Bahar, and entitled, Active Components And Membranes For Electrochemical Compression; the entirety of which is hereby incorporated by reference. Composite membranes having a thickness of 25 μm or less, including 20, 15 and even 10 μm or less are disclosed. These thin composite membrane may comprises polybenzimidazole (PBI) which does not require hydration of the membrane as does PFSA membrane. PBI membranes are typically functionalized with phosphoric acid to provide proton mobility. The imidazole rings are capable of functioning as a proton donor or proton acceptor. PBI membranes are also broadly chemical resistant and has high strength and structural stability. Since the (PBI/PTFE) composite membrane derives its proton conductivity from functionalization with phosphoric acid, the membrane is able to operate in a “dry state”, eliminating the need for desiccation of the high pressure hydrogen gas upstream of the metal hydride reactor. In an exemplary embodiment the metal hydride heat pump comprises an electrochemical compressor that incorporates a composite PBI membrane that has a thickness of 25 μm or less, including 20, 15 and even 10 μm or less, and any range between and including the thickness values provided.

[0037] In another embodiment, a second class of membranes based on a combination of pyridine and polysulfone for electrochemical applications is utilized in the electrochemical compressor. Sold under the TPS brand by Advent Technologies, these pyridines and polysulfone materials are provided as a raw extruded film. In an exemplary embodiment, the pyridine and polysulfone materials are made into composite membranes, such as by casting them on or into ultra-thin, strong, porous reinforcing material, such as ePTFE membrane (sold under the Gore-tex brand) by W.L. Gore And Associates, Newark, Del. A composite membrane, as described herein, may be thin, strong, and high performance and capable of being functionalized with Phosphoric acid. A composite membrane may comprise an integral reinforcing membrane, such as ePTFE membrane, or may comprise reinforcing discrete elements, such as fibers that are disposed on or into the ionomer material, i.e. PFSA, PBI or the combination of pyridine and polysulfone.

[0038] Membranes comprising polybenzimidazole or combinations of pyridine and polysulfone exhibit higher ionic resistivity than traditional ion exchange membranes of similar thickness, however, in thin composite form, the films can be made almost an order of magnitude thinner and therefore provide low overall resistance. The graph provided in FIG. 4 shows some of the properties of the TPS films, again a combination of pyridine and polysulfone. But most importantly, the films do not generally need water for proton conduction, and as a result can tolerate dry hydrogen input and provide dry hydrogen output suitable for metal hydride storage. The membranes can be further modified to include tertiary components such as silica or zeolites that can further entrain moisture (if any) or any other contaminants and ensure cleaner output (compressed gas).

[0039] It is important to recognize that metal hydride need specific pressures to absorb hydrogen, and other specific pressures, generally lower than the absorption pressures to desorb the hydrogen. The ratio of the absorption to desorption pressure Higher efficiencies are gained when the pressure ratio of the pressure of the output gas to the pressure of the incoming gas is minimized. In one embodiment, the

pressure ratio of the electrochemical compressor is as high as 20 or more, or about 30 or more, 35 or more and any range between and including the pressure ratio's provided. However, lower ratios are better, and more efficient (i.e. require less power). Some metal hydrides such as for example (see attached table) $\text{LiNi}_4.8\text{AlO}_2$ are reported to have P(low) of 2.47 atm and a P(high) of 35.84 atm i.e. a pressure ratio requirement of 14.51; another hydride $\text{Mm Ni}(4.7) \text{Fe}(0.3)$ has a P(L) of 1.29 atm and a P(H) of 12.14 i.e. a ratio of 9.41.

[0040] It is important to understand, that the metal hydride heating system, or heat pump described herein is not only interested in low pressure ratio metal hydrides (for highest efficiency) but also materials that have heat/cool enthalpies (i.e. KJ/mol H_2 absorbed or desorbed) and high hydrogen absorption, low density (weight), and also high recycling capacity.

[0041] For most appliance applications, literally thousands, perhaps as many as millions of cycles are required. Novel and specific operating strategies that maximize metal hydride cycle life, are provided:

[0042] a. Where the metal hydride is not stretched to its physical limits i.e. not to its lowest desorption pressure and highest desorption pressure (i.e. pressure ratios less than their reported absolute limits are used i.e. 90% or 80% or 50% of their pressure limits). By doing this the medium is not expanded or contracted to its full extent and therefore not compromised. i.e. had its life shortened. In other words, the absorption and desorption remains in the linear portion of the “vant hoff” plots for the specific compound as shown in FIG. 13.

[0043] b. Hydrogen gas is fed in the driest state possible, such for example inserting a desiccant system that is used less periodically—perhaps not each time the system is cycled, but once in a while, so that the parasitic load for desiccation is minimized. A side loop or stream that can be opened and shut periodically could be established with a desiccation system put in place to effectively ensure the cleanliness of the hydrogen gas.

[0044] c. Additives are added to the metal hydride such as fluoropolymer powder or silica etc. (to those familiar with the art) to enable hydrogen gas to access metal hydride media, but to also allow for expansion and contraction without the hydride powder bumping into each other and damaging adjacent particles. Fluoropolymer particles or powder added to the metal hydride may prevent metal hydride particles from fusing together and may maintain a high surface area of hydrating.

[0045] d. Metal hydride powder could be packaged in tubes (such as ePTFE tubes) and connected to a central mandrill and contained in a uniform and consistent manner to allow for gas access, but also stable containment without excessive movement and bumping into other particles. While there are patents for similar systems, they all use metal tubing. As described herein, porous ePTFE tubes are provided (as well as other similar porous materials) as an alternative containment system. The metal hydride medium may be segregated inside narrow tubes, so that not only the material is ‘separated’ from creating a large ‘fused block’ but to also provide very high surface area for heat exchange as well as a short distance to the metal hydride material itself to improve heat exchange efficiency.

[0046] e. Another approach would be to put the metal hydride medium inside a small canister that may have open ports, or inside an expanded PTFE (ePTFE) tube, such as either in a continuous line, or in small packets and then place these packets inside a larger cylinder for hydriding and safe storage and handling. Expanded PTFE tubes can be purchased from companies such as W.L. Gore & Associates or Phillips Scientific. Any suitable permeable tubing that can withstand the chemical and temperature requirements of the metal hydride heat exchanger may be used. One benefit of the ePTFE systems is that they can withstand thermal activity, not only when the system absorbs hydrogen, but also, when the metal hydride is initially preheated and prepared for the hydriding system. Alternatively, plastic straws made of thermally conductive plastic (such as those made by Celanese) may be used to house the hydride material—rather than a porous medium, or a metal tube, and then these straws can be connected to a header for hydriding purposes. These tubes could be plugged with stainless steel frit or porous plastic to ensure that the metal hydride remains in the tube, while hydrogen can access it.

[0047] f. Metal Hydride housings may also be made using various layers of conductive materials such as aluminum and thermal plastics, etc. to avoid any hydrogen escape directly through the material in question

[0048] In the most traditional of metal hydride heat pump systems (MHHCS), a compressor sits between two metal hydride tanks that are sequentially filled and emptied with hydrogen. An electrochemical compressor's polarity can be reversed, or multiple compressors can be used for this.

[0049] While this is obviously feasible, alternative configurations are feasible, with say two different metal hydride compounds in different tanks, or where the output from one hydride tank enters the input of the other tank (i.e. the P(I) of one tank is that P(H) of the other tank). This is termed a regenerative unit.

[0050] The benefit of a regenerative unit is that now the electrochemical compressor only needs to 'pump' in one direction from the P(I) of the Low (receiving tank) to the P(H) of the other tank. By not reversing the polarity of the ECC, membrane and electrode life are maximized, and system reliability is retained. In an exemplary embodiment, the metal hydride heating system describe herein is a regenerative system, and may function in a mode wherein the polarity of the ECC is NOT reversed, which may provide a better, more durable system.

[0051] In this context, one option for creating a high compression ratio from an electrochemical compressor, is to put multiple cells in series. In a normal compressor configuration, the cells are plumbed in parallel, but powered in series. But where higher compression ratios are required for specific metal hydrides or hydride tank configurations, MEA's can be combined i.e. plumbed in series initially in short trains, and then in parallel as usual. One benefit of short MEA trains is the exponential increase in pressure feasible. One important benefit of this system, is that individual MEA's can be operated at lower discrete voltages i.e. closer to their Nernst potential, and then combined so that the compressor as a whole can be operated at the bus voltages required by electronics system employed for the specific appliance where the MHHCS is required.

[0052] In an exemplary embodiment, a first hydride portion or tank comprises a metal hydride that has a desorption pressure that is higher than an absorption pressure of a second metal hydride contained within a second metal portion. The first and second metal hydride portions may be configured in series in a loop closed loop configuration of a metal hydride heat transfer system, or in parallel. In one embodiment a first and second metal hydride portion having different metal hydrides therein are configured on the same side of an electrochemical compressor and in another embodiment they are configured on opposing sides of an electrochemical compressor.

[0053] It is also important to recognize that the low pressure entering the compressor can be sub-ambient or at least low enough that the hydrogen gas may have problems being transported to the surface of the electrode(s). Xergy Inc. has developed back ported and side ported cell technology (patented in the past) that allows for low pressure feeds. These systems allow the MEA's to "breathe". An exemplary metal hydride heating system, as described herein, may operate at low pressures, utilizing low pressure absorption/desorption metal hydrides and breathing design cells for use with metal hydride systems. Note that traditional compressors (in the past) have been variants of automotive fuel cell designs with inlet ports place within bipolar plates. i.e. not side ported (at 90 degrees to the cells), but in the direction as the cell assembly plane.

[0054] One other novel improvement to MHHCS systems with ECC compressors provided herein, is the use of another side stream of input hydrogen from a small electrolyzer (generator) in connection with water, where hydrogen is produced, put through the desiccant column and then added to the MHHCS system to make up for any hydrogen that may be depleted over time as it irreversibly complexes with metal hydride compounds. Or alternatively a small side cylinder of hydrogen can be provided for this purpose.

[0055] The invention is directed to an electrochemical compressor-driven metal hydride heat pump system. In one embodiment, an electrochemical compressor, as described herein, comprises an electrochemical cell and a working fluid consisting of hydrogen. The electrochemical cell is capable of producing high-pressure gas consisting of an electrochemically-active component, such as hydrogen.

[0056] A heating or cooling device, as described herein, comprises an electrochemical hydrogen compressor or hydrogen compressors coupled to at least one tank, (preferably two) containing a packed bed of metal hydride-forming alloy, that may systemically be configured in thermal communication with an object to be heated, as shown in FIG. 2. A heating device, as described herein, comprises an electrochemical compressor configured to control the pressure of hydrogen gas passing between at least two metal hydride tanks. The absorption of hydrogen gas into suitable metal alloy leads to the exothermic formation of a metal hydride, producing useful heat as shown in FIG. 1A. The endothermic desorption of hydrogen gas is reversible, requiring about as much heat as that released by absorption, which thereby produces useful cooling, as shown in FIG. 1B.

[0057] In an exemplary embodiment, a working fluid comprises or preferably consists essentially of pure, dry hydrogen. In an exemplary embodiment, the working fluid consists of at least 90% hydrogen, or at least 95% hydrogen, or at least 99% hydrogen. The electrochemical compressor

comprises a membrane electrode assembly that comprises an anode, a cathode, and a cation exchange membrane located between the anode and cathode.

[0058] In an exemplary embodiment, the cation exchange membrane comprises a phosphoric acid-functionalized polybenzimidazole/polytetrafluoroethylene (PBI/PTFE) composite membrane, however any cation exchange material may be used that can operate at low humidity and high temperatures (100-200° C.) with high mechanical durability. The composite membrane may also include an additive such as silica to further assist in dry hydrogen compression. The anode and cathode comprise a catalyst suitable for running the reactions as described herein. At the anode, hydrogen is oxidized into protons and electrons. The protons are then transferred across the cation exchange membrane to the cathode, where the hydrogen is produced through a reduction reaction. A power supply may be coupled to the anode and cathode to drive the reactions and transfer the hydrogen working fluid across the membrane electrode assembly at constant volume, thereby pressurizing the hydrogen. A working fluid inlet is coupled with the anode, or anode side of the electrochemical compressor and a working fluid outlet is coupled with the cathode, or cathode side of the electrochemical compressor. An electrochemical compressor-driven metal hydride heating element further comprises at least two tanks of metal hydride-forming material between which the compressor passes the hydrogen. Heat transfer elements thermally coupled to the tanks, including but not limited to heat exchange coils circulating a suitable heat transfer medium, can be used in conjunction with a circulator pump to transfer useful heat produced away from whichever metal hydride tank is exothermically absorbing hydrogen at the moment. The invention can be alternately used as a cooling unit by modifying the heat exchange loop to transfer useful cooling from a metal hydride tank undergoing endothermic desorption.

[0059] The high pressure side of the compressor stream could be used to drive a turbine, to help in pumping the liquid in communication with the heat exchanges.

[0060] Note this system could be applied to a wide variety of applications already disclosed such as hot water heaters, but also to very cool (cryogenic) type applications depending on the hydride selected.

[0061] Silica or other additives can be added to the membrane (to improve performance). And the use of a composite ion exchange membrane certainly add to the ability of the system to withstand pressure difference

[0062] While the example provides for two hydride beds in communication with a single compressor, one could potentially use two compressors as opposed to one, so you minimize valving and the compressor(s) can be operated at pressures above the low pressure and below the high pressure points of the hydride (to minimize hydride stresses and extend hydride life). Could be say 80% of the range.

[0063] In fact, it is preferable to use metal hydrides where the ratio of high pressure to low is minimized (i.e. more efficient system). And one hydride tank and a second non-hydride storage bottle(s) saving on expensive hydride supply.

[0064] It is possible to use air for cooling, and the liquid loop for heating purposes in thermal communication with the hydride bed.

[0065] For the purposes of this disclosure, the tubular elements that contain metal hydrides are referred to as heat exchangers.

[0066] A heat exchanger is a device used to transfer heat between one or more fluids. The fluids may be separated by a solid wall to prevent mixing or they may be in direct contact. It is important to recognize that heat exchangers can be classified in many different ways. For the purposes of this disclosure, heat exchangers are characterized into recuperative and regenerative types. Most appliances use recuperative type heat exchangers. A regenerative heat exchanger, or more commonly a regenerator, is a type of heat exchanger where heat from the hot fluid is intermittently stored in a thermal storage medium before it is transferred to the cold fluid. To accomplish this, the hot fluid is brought into contact with the heat storage medium, then the fluid is displaced with the cold fluid, which absorbs the heat. A metal hydride container may be considered a regenerative heat exchangers, as further described herein. For example, a secondary working fluid may be used to exchange heat with the metal hydride heat exchanger for delivery to another thermal reservoir as needed in the appliance in question. A secondary working fluid, or heat exchange fluid, may be any suitable fluid including, but not limited to, water, ethylene glycol, or simply air or a gas—as needed.

[0067] In an exemplary embodiment, there is a primary loop of an electrochemical compressor driving a working fluid such as hydrogen into a metal hydride bed (heat exchanger), and eventually (directly or indirectly) receiving the same fluid back to the electrochemical compressor, and a secondary loop of a secondary working fluid, or heat exchange fluid, that actually exchanges heat with the metal hydride heat exchanger and carries the heat from the heat exchanger to a secondary location, such as appliance.

[0068] In an exemplary embodiment, an electrochemical compressor and metal hydride heat exchanger or pump are configured in a hybrid hot water system. The heat pump may utilize ethylene glycol as the heat exchange fluid and the ethylene glycol may be pumped through or around a metal hydride heat exchanger and then into a hot water heater, where it is in thermal communication with water within the tank to heat the water within the tank. A coil of tubing that transports the ethylene glycol may be configured in the bottom of the hot water tank for heating the water therein, for example. The ethylene glycol travels in a loop and releases its heat to the water, and may optionally also exchange heat also using classical air coil(s) with the environment.

[0069] Metal hydride beds, or heat exchangers may comprise of many different types of hydrides and formulations. Depending on the appliance involved, the metal hydride formulation may be optimized for different temperature (and or pressure) regimes for the specific application. For example, for heating a system based on LaNi(4.8)Al(0.2) may be employed and for cryogenic cooling a system may employ TiCr(1.9). It is not uncommon in regenerative systems for metal hydride materials in different tanks to be made of different alloys, and the output from one unit be used as the input for another one. Also, it is entirely feasible that a secondary loop, or heat exchange loop, for one tank (hydride heat exchanger) may be different to the secondary loop for a second tank. i.e. one could be air cooled and another water cooled.

[0070] Virtually all metal hydrides are sensitive to contamination with water, therefore it is critical to ensure that the impact of water be minimized. One way to do this is to use a classical desiccant (water removal) system in line between the compressor and the metal hydride heat exchanger, as described herein. However, desiccant may also be added as a 'topping' layer to the metal hydride system, or even blended in with the metal hydride to preferentially absorb the water. One known desiccant medium is silica, but there are countless other materials well known in the art. Desiccant media may also contain catalytic materials such as palladium or platinum that can accelerate water absorption or conversion of any contaminants in the hydrogen stream.

[0071] Tubes could be placed in shell and tube heat exchanger type configurations, and water or ethylene glycol could be circulated in the shell, with baffles, to ensure high thermal transfer; and operation with minimal sensible heat loss.

[0072] Once the heat exchangers are established, clearly operating the hydrogen compressor, and configuration of the plumbing lines is vital for overall successful operation.

[0073] Depending on what membrane is used, the electrochemical compressor may need to be preheated before start-up and some areas of the lines may need to be preheated too. Obviously, stacks can contain a layer of (flat) heating plate to help with start-up and temperature maintenance. This might be especially important on a cold day.

[0074] One benefit of a metal hydride heat pump is that the heat generated (or removed) is cycled, and the rate of cycling determines the total wattage of heating or cooling available. Thus appliance operators can, set different cycling rates for different points in an appliances operation—to ensure most efficient operation. Also, electrochemical compressors can be operated at different operating points.

[0075] Thus for example, in a hot water heater, the system can be cycled frequently if there is a sudden high volume demand for hot water, or cycled slowly if the system is simply trying to maintain the tank at a given temperature without any water demand.

[0076] Examples of plumbing configurations are provided. Note that in these examples, the compressor is always operating in the same direction. However, compressors can also operate with polarity being reversed instead of using valves to control the direction of flow.

[0077] In an exemplary embodiment, an electrochemical compressors can be provided with integrated secondary loop for heat exchange with the metal hydride. For example, plumbing of a secondary loop may be configured pass through at least a portion of the bipolar plates. In addition, the bipolar plates may be designed to have integrated metal hydride beds to absorb or desorb hydrogen and produce and receive heat. This integrated system reduces the potential for losses of hydrogen from connections and valves, concentrates the heat exchanger around the compressor and reduces complexity. An integrated metal hydride heat exchanger may not require any valves. The whole unit can be made smaller; and integrated into one hermetically sealed unit that performs all the key functions required for heat exchange.

[0078] Exemplary bipolar plates of an integrated metal hydride heat exchanger can be made of two stamped metal plates, and laser welded on the seams. A secondary fluid or heat exchanger fluid can be ported in and out of the bipolar plates. The system can be filled with Hydrogen gas through

external porting and then simply supplemented with hydrogen when an if necessary. An integrated metal hydride heat exchanger may be designed to be fully hermetically sealed or configured inside a hermetically sealed enclosure. An exemplary metal hydride heat exchanger may comprise a plurality of electrochemical compressor units in series. Hydrogen may be pumped one direction to produce heat and then reversed to draw heat from the heat exchange loop that is integrated into the system.

[0079] The summary of the invention is provided as a general introduction to some of the embodiments of the invention, and is not intended to be limiting. Additional example embodiments including variations and alternative configurations of the invention are provided herein.

BRIEF DESCRIPTION OF SEVERAL VIEWS OF THE DRAWINGS

[0080] The accompanying drawings are included to provide a further understanding of the invention and are incorporated in and constitute a part of this specification, illustrate embodiments of the invention, and together with the description serve to explain the principles of the invention.

[0081] FIG. 1 shows metal hydride during absorption.

[0082] FIG. 2 shows metal hydride during desorption.

[0083] FIG. 3 shows an exemplary process flow diagram.

[0084] FIG. 4 shows an exemplary polarization curve.

[0085] FIG. 5 shows a graph of some of the properties of the TPS films.

[0086] FIG. 6 shows a schematic of an electrochemical cell of an electrochemical pump.

[0087] FIG. 7 shows an exemplary metal hydride heat pump.

[0088] FIGS. 8 to 10 show a cross-sectional views of a composite ionomer membrane comprising a reinforcing material.

[0089] FIG. 11 shows a schematic of an exemplary heat transfer system comprising a desiccation unit.

[0090] FIGS. 12 and 13 show schematics of a hydride portion wherein FIG. 12 is a side view and FIG. 13 is a cross-section along line 13-13 of FIG. 12.

[0091] FIG. 14 shows isotherms for metal hydrides.

[0092] FIGS. 15 and 16 show an exemplary electrochemical heat transfer system having two separate metal hydride portions and a desiccation unit.

[0093] FIGS. 17 and 18 show an exemplary electrochemical heat transfer system having two separate metal hydride portions and series of valves to flow hydrogen from one metal hydride portion to the other.

[0094] FIG. 19 shows an exemplary metal hydride heat exchanger having a secondary loop for transfer of heat from the metal hydride heat exchanger.

[0095] FIG. 20 shows a diagram of an exemplary integrated electrochemical compressor and metal hydride heat exchanger.

[0096] FIG. 21 shows a diagram of an exemplary integrated electrochemical compressor and metal hydride heat exchanger.

[0097] FIG. 22 shows a diagram of an exemplary integrated electrochemical compressor and metal hydride heat exchanger having a heat transfer fluid conduit configured through the cell.

[0098] FIG. 23 shows a diagram of an exemplary simplified end plate design for an electrochemical cell.

[0099] FIG. 24 shows an exemplary electrochemical stack having the cathodes of adjacent cells configured adjacent each other.

[0100] FIG. 25 shows a diagram of an exemplary electrochemical cell having integrated cell channels and connections.

[0101] FIGS. 26 and 27 illustrate how an electrochemical compressor unit is integrated into a vehicle seat.

DETAILED DESCRIPTION OF THE ILLUSTRATED EMBODIMENTS

[0102] Corresponding reference characters indicate corresponding parts throughout the several views of the figures. The figures represent an illustration of some of the embodiments of the present invention and are not to be construed as limiting the scope of the invention in any manner. Further, the figures are not necessarily to scale, some features may be exaggerated to show details of particular components. Therefore, specific structural and functional details disclosed herein are not to be interpreted as limiting, but merely as a representative basis for teaching one skilled in the art to variously employ the present invention.

[0103] As used herein, the terms “comprises,” “comprising,” “includes,” “including,” “has,” “having” or any other variation thereof, are intended to cover a non-exclusive inclusion. For example, a process, method, article, or apparatus that comprises a list of elements is not necessarily limited to only those elements but may include other elements not expressly listed or inherent to such process, method, article, or apparatus. Also, use of “a” or “an” are employed to describe elements and components described herein. This is done merely for convenience and to give a general sense of the scope of the invention. This description should be read to include one or at least one and the singular also includes the plural unless it is obvious that it is meant otherwise.

[0104] Certain exemplary embodiments of the present invention are described herein and are illustrated in the accompanying figures. The embodiments described are only for purposes of illustrating the present invention and should not be interpreted as limiting the scope of the invention. Other embodiments of the invention, and certain modifications, combinations and improvements of the described embodiments, will occur to those skilled in the art and all such alternate embodiments, combinations, modifications, improvements are within the scope of the present invention.

[0105] As shown in FIGS. 1 and 2, metal hydrides 42 release heat when hydrogen is absorbed and receives heat when the hydrogen is desorbed from the metal hydride. Absorption is exothermic, releasing heat, and desorption is endothermic, conducting heat. The metal hydride may be a hydride forming alloy 43, as described herein.

[0106] As shown in FIG. 3, an exemplary electrochemical heat transfer system 19 comprises an electrochemical heat transfer device 10 comprising an electrochemical compressor 12, such as a hydrogen compressor, that is coupled to at least one metal hydride reservoir 40 that contains a metal hydride-forming alloy 43, such as in a packed bed. The metal hydride reservoir is in thermal communication with heat exchanger 47, or with an object to be heated. The metal hydride reservoir or housing, or portion thereof, may be a heat exchanger 47 and be in thermal communication with an object to be heated or cooled or have a fluid flowing through it. The electrochemical heat transfer system may be config-

ured as a heating device, wherein the heat exchanger is coupled with a metal hydride reservoir that is absorbing hydrogen and thereby releasing heat. The electrochemical heat transfer system may be configured as a cooling device, wherein the heat exchanger is coupled with a metal hydride reservoir that is desorbing hydrogen and thereby conducting heat. The electrochemical heat transfer system may be configured as a heating and cooling device, wherein the heat exchangers of the absorbing and desorbing metal hydride reservoirs are in thermal communication with an object or volume of air to be heated and cooled, respectively. The absorption of hydrogen gas into suitable metal alloy leads to the exothermic formation of a metal hydride, producing useful heat as shown in FIG. 1. The endothermic desorption of hydrogen gas is reversible, requiring about as much heat as that released by absorption, which thereby produces useful cooling, as shown in FIG. 2.

[0107] As shown in FIG. 3, two separate electrochemical compressors 40, 50, or hydrogen compressors are configured in a closed loop between a first metal hydride reservoir 40 and a second metal hydride reservoir 50. Conduits 27-27'' couple the components of the system and enable hydrogen to flow between the electrochemical compressors and the metal hydride reservoirs. A series of valves 26-26'' are controlled by the controller and are opened and closed to enable hydrogen flow as required. The controller also controls the electrochemical compressors, wherein the voltage and/or current is controlled to produce a flow of hydrogen across the membrane electrode assembly 13. The first metal hydride reservoir 40 is desorbing hydrogen to the first electrochemical compressor 12 and therefore conducting heat, or is the cool reservoir. The second metal hydride reservoir 50 is absorbing hydrogen from the first electrochemical compressor 12 and is releasing heat, or is the hot side. Valves 26 and 26' are open during this process and valves 26'' and 26''' are closed. After the hydrogen has been pumped from the first metal hydride reservoir 40 to the second metal hydride reservoir 50, the valves 26'' and 26''' may be opened and valves 26 and 26' may be closed to allow the hydrogen, now in the second metal hydride reservoir 50 to be pumped to the first metal hydride reservoir 40 by the second electrochemical compressor 12'. Each of the metal hydride reservoirs contains a volume of metal hydride 52.

[0108] A polarization curve utilizing the membrane in hydrogen compression mode is shown in FIG. 4. The performance of the ECC-driven heat pump system will vary depending on the specific metal hydride composition. LaNi₅ has been used for heat pumping in the past. Preferably a LaNi_{4.7}Al_{0.3} has been shown to operate with a better pressure ratio that is better suited for electrochemical compression, wherein there may be a low pressure requirement of 7 psi and high pressure requirement of 28 psi. This pressure range is well suited for domestic hot water applications. For enhanced heat transfer from the packed bed, a metal hydride reservoir may have a tubular geometry with an aspect ratio, cylinder height to diameter, of at least 5, or at least 10, so as to minimize radial thermal gradients in the packed hydride bed. Heat transfer within the packed bed will be augmented by adding thermal-conductivity enhancing materials such as aluminum foam in order to overcome the metal hydride's low thermal conductivity. A thermally conductive material or network may be configured within the metal hydride reservoir. Effective heat transfer to and from the metal hydride packed bed governs its rate of hydrogen

charging and discharging, which in turn governs the ability of the electrochemical compressor to drive or pump hydrogen and therefore the overall heat transfer rates. The quicker heat can be conducted and released, the higher the heat transfer rate to a heat exchanger or to an object.

[0109] FIG. 5 shows a graph of some of the properties of the TPS films. The graph shows the phosphoric acid (PPA) concentration as a function of increasing temperature. The TPS functions well with very low moisture content at high temperatures.

[0110] FIG. 6 shows a schematic of an electrochemical cell of an electrochemical pump. The electrochemical compressor 12 comprises a membrane electrode assembly 13 comprising an anode 30, a cathode 32 and an ionomer layer 34 configured there between. The ionomer layer 34 may be a proton exchange polymer 31 or a composite ionomer membrane comprising a proton exchange polymer, for example. The pressure on the anode side 35 will be less than the pressure on the cathode side 36 of the membrane electrode assembly, as the compressor is pumping hydrogen from the anode side to the cathode side. The pump is driven by a power source 28 that is electrically connected to the anode and cathode to drive the reactions provided in FIG. 5. The electrochemical compressor 12, or hydrogen pump 15, is configured with an inlet 22 and outlet 24. A conduit 27 extends from the inlet to a first metal hydride portion that is desorbing hydrogen and conducting heat, and conduit 27' extends from the outlet to a second metal hydride portion that is absorbing hydrogen and releasing heat.

[0111] FIG. 7 shows an exemplary metal hydride electrochemical heat transfer device 10 that comprises an electrochemical hydrogen compressor 12. The electrochemical compressor 12 pumps hydrogen from an anode side 35, and from a first metal hydride reservoir 40 across the membrane electrode assembly 13 to the cathode side 36 and into a second metal hydride reservoir 50 such as a tank or enclosure for the metal hydride forming alloy 53 material. The metal hydride 52 material may be a packed bed or a monolith for example. The metal hydride reservoir may comprise an additive 51 such as fluoropolymer, silica or metal such as copper, to aid in expansion and contraction of the metal hydride. The compressor may be reversed, wherein the controller 90 changes the potential of the power supply 28 to switch the anode to the cathode or the cathode to the anode. In this way, hydrogen can be pumped back and forth between the two metal hydride reservoirs. Heat transfer devices 47, 57 are coupled to the metal hydride portion 40, 50' respectively. The heat transfer device may transfer heat to and/or from the metal hydride reservoir to an article or to the air or environment. A heat transfer device may comprise fins, a conduit for a flow of a heat transfer fluid, a conducting plate, and the like.

[0112] As shown in FIGS. 8 through 10, an ionomer layer 34 is a composite ionomer membrane 66 having a reinforcing material 62. The reinforcing material 62, such as a membrane or discrete reinforcing elements or fibers, may be configured within the ionomer 60, wherein the ionomer is exposed on either side of the reinforcing material, as shown in FIG. 7. In an alternative embodiment, the reinforcing material is configured to one side of the composite ionomer membrane 66, as shown in FIG. 8. In another embodiment, the reinforcing material 62 extends through the thickness 65 of the composite ionomer membrane 66, wherein there is substantially no ionomer layer on the top or bottom surface,

as shown in FIG. 9. The composite ionomer membrane may be very thin to enable quick transfer of hydrogen and therefore a higher heating flux rate. The composite ionomer membrane may be about 30 μm or less, about 25 μm or less, about 20 μm or less, about 15 μm or less, about 10 μm or less, about 5 μm or less. The ionomer 60 interpenetrates the reinforcing material 62. The ionomer and/or the composite ionomer may have an additive 68, to improve performance such as silica or other desiccant particles, or reinforcing materials, as described herein.

[0113] As shown in FIG. 11, an exemplary electrochemical heat transfer device 10 comprises desiccation units 48 and 58 configured between the metal hydride portion 40 and 50 and the electrochemical compressor 12, respectively. The first metal hydride reservoir 40 is coupled to the desiccation unit by conduit 27 and a desiccation valve 49 can be opened to flow hydrogen into the desiccation unit 48, or bypass it. Likewise, the second metal hydride reservoir 50 is coupled to the desiccation unit by conduit 27' and a desiccation valve 59 can be opened to flow hydrogen into the desiccation unit 58, or bypass it. The desiccation valves may be used to force a flow of hydrogen through the desiccation unit as needed. A humidity sensor 85 may monitor the humidity level and a control system 90 may open and close the valve to the desiccation unit as a function of the humidity level measures, whereby it opens the valve for gas desiccation when the humidity exceeds a threshold value, such as 1% or more, or 2% or more, or 5% or more. A heat exchanger 47 is coupled with the first metal hydride reservoir 40 to conduct heat into the metal hydride 42 and a heat exchanger 57 is coupled with the second metal hydride reservoir 50 to conduct heat from the metal hydride 52, as indicated by the bold arrows.

[0114] As shown in FIGS. 12 and 13, a metal hydride reservoir 40 comprises a tube 79 having an interior mandrel 77 for distributing the hydrogen gas 11 to the metal hydride forming alloy 43. The mandrel 77 provides an open conduit to distribute the hydrogen gas down along the tube and into the metal hydride forming alloy configured between the mandrel and the interior wall of the tube. A tube may be circular in cross-sectional shape, as shown or take any other suitable cross-sectional shape, such as polygonal, square, rectangular irregular and the like. A large aspect ratio, length 78 of the tube to outer diameter 75 of the tube may be large, such as greater than 5, and preferably greater than 10, to provide quick transfer of hydrogen to the metal hydride and to enable quick heat transfer rates.

[0115] FIG. 14 shows exemplary isotherms of metal hydrides wherein the absorption pressure is higher than the desorption pressure. There is a linear region for the absorption and desorption.

[0116] As shown in FIGS. 15 and 16 an exemplary electrochemical heat transfer device 10 comprises a single electrochemical compressor 12 and a closed loop system that transfers hydrogen from a plurality of metal hydride reservoirs 40, 50, to a hydrogen reservoir 69 which may be a desiccant unit 69. As shown in FIG. 15, the electrochemical compressor 12 is pumping hydrogen from the desiccant unit 69 to the two metal hydride reservoirs 40, 50 and valves 26" and 26'" are closed. As shown in FIG. 16, the electrochemical compressor 12 is pumping hydrogen from the two metal hydride reservoirs 40, 50 to the desiccant unit 69 and valves 26 and 26' are closed. A heat transfer device 47, 57 is in thermal communication with first and second metal

hydride reservoirs **40**, **50**, respectively. The heat exchangers may engage and disengage in thermal communication with the metal hydride reservoirs depending on the application. For example, when the exemplary electrochemical heat transfer device **10** is configured as a heater, the heat transfer devices may be in thermal communication with the metal hydride reservoirs during absorption of hydrogen, as shown in FIG. **15** and detached when desorbing hydrogen, as shown in FIG. **16**. The desiccant unit may be most effectively configured between the electrochemical compressor and the hydride reservoir, or just before a hydride reservoir.

[0117] As shown in FIGS. **17** and **18**, an exemplary electrochemical heat transfer device **10** is configured to pump hydrogen from a first metal hydride reservoir **40** to a second metal hydride reservoir **50** and vice versa. As shown in FIG. **17**, the first metal hydride reservoir is receiving and absorbing hydrogen that is pumped by the electrochemical compressor **12** from the second metal hydride reservoir **50**. As shown in FIG. **18**, the second metal hydride reservoir **50** is receiving hydrogen that is pumped by the electrochemical compressor **12** from the first metal hydride reservoir. The hydrogen goes through a desiccant unit **69** during this step. It is to be understood that a desiccant unit may be configured on both portion of the loop. Also, a bypass conduit **96** may extend around the desiccant to allow the hydrogen to bypass the desiccant unit. A desiccant bypass valve **95** may open to allow the working fluid to bypass an desiccant unit **69**.

[0118] As shown in FIGS. **17** and **18**, the conduits **27** forms a closed loop with the two metal hydride reservoirs **40**, **50**, coupled to the loop. An outlet portion conduit **94** couples the metal hydride reservoirs **40** and **50** on the outlet side of the electrochemical compressor and an inlet portion conduit **92** couples the metal hydride reservoirs **40** and **50** on the inlet side of the electrochemical compressor. There is a first outlet portion valve **26** configured between the electrochemical hydrogen compressor and the first reservoir **40** on the outlet portion conduit **94** of the closed loop. There is a second outlet portion valve **26'** configured between the electrochemical hydrogen compressor **12** and the second reservoir **50** on the outlet portion of the closed loop. There is a first inlet portion valve **26''** configured between the electrochemical hydrogen compressor **12** and the first reservoir **40** on the inlet portion **92** of the closed loop. There is a second inlet portion valve **26'''** configured between the first electrochemical hydrogen compressor **12** and the second reservoir **50** on the inlet portion **92** of the closed loop. This configuration, with the electrochemical compressor coupled to the closed loop, with the outlet of the compressor coupled to the outlet portion **94** of the closed loop and between valves **26** and **26'** and coupled to the inlet portion **92** of the closed loop and between valves **26''** and **26'''**, enables working fluid to be pumped in one direction and cycled from metal hydride reservoirs by opening and closing the valves as shown. This unique plumping configuration and method of opening valves enables streamline operation of the heat transfer system.

[0119] FIG. **19** shows an exemplary metal hydride heat exchanger **67** having a metal hydride reservoir **40** and a heat exchange device **47**. The metal hydride reservoir is a tube **79** that contains a metal hydride **43**. The heat exchanger device **47** comprises a heat transfer conduit **76** that is coiled around the tube, or cylinder and a heat transfer fluid **82** passes through the conduit. The heat transfer device **47** also comprises a heat transfer conduit **83'** that is in direct communi-

cation with the metal hydride. As shown, the heat transfer conduit **83'** passes through the cylinder or tube, wherein the conduit is in direct contact with the metal hydride **43**. The interior heat transfer conduit **76'** may be coiled around the interior of the cylinder to increase thermal conductivity. The heat transfer fluid may be a gas, or a liquid, such as water. Any suitable type of heat exchange fluid may be configured to flow through secondary loop as described herein.

[0120] FIG. **20** shows an exemplary electrochemical compressor **12** having side ports, or channels **71** for receiving hydrogen **11**. Metal hydride reservoirs **40**, and **50** are configured on the anode and cathode sides of the membrane electrode assembly **13**. Hydrogen flows through the channels and into and out of the metal hydride **42**, **52**. The hydrogen then flows from the anode side **35** to the cathode side **36**. Note that the narrow and long with side porting increase the distribution rate of hydrogen to the metal hydride reservoir and therefore increases heat transfer rates. In addition, this type of side porting reduces pressure drop of hydrogen into and out of the electrochemical cell. The hydrogen has to pass from the channels **71** through the gas diffusion media **37** to the electrode, anode or cathode. This quick distribution of hydrogen to the membrane electrode assembly can also increase current density, as the fuel is not limiting. As shown in FIG. **20**, heat exchange conduits **76**, **76'** extend through the electrochemical cell, and are in direct physical contact with the metal hydride reservoirs, **40**, **50** respectively. A heat exchange fluid may flow through the conduit to exchange heat with the metal hydride **52**. In another embodiment, instead of heat exchange conduits, a heat exchange element may extend through the cell and be in contact with the metal hydride reservoir and extend out from the cell to act as heat conductors, or fins. Air flowing over the extended fins, may carry heat to or from the electrochemical cell.

[0121] FIG. **21** shows an exemplary integrated electrochemical compressor and metal hydride heat exchanger **17**. As shown, the electrochemical cell **16** is configured between heat exchange conduits **76**, **76'**. As described herein any number of electrochemical cells may be configured in series in the heat exchanger. The bipolar plate **70**, or plate with channels **71** configured to distribute a working fluid, i.e. hydrogen, over the surface of the gas diffusion media **37** is in thermal communication with the heat exchange conduits **76**. A current collector **38** is shown being in electrical contact with the gas diffusion media **37** and the bipolar plate **70**. A bipolar plate may have a serpentine channel or a series of channels that are coupled together to a common channel or inlet. As shown in FIG. **22** a metal hydride **42** that is coupled to, configured in, on is an integral part of the bipolar plate **70**. The bipolar plate comprises a metal hydride bed **74** that forms the metal hydride reservoir **40**, and may be a recessed region in the bipolar plate. The metal hydride in a bipolar plate is in fluid communication with the channels or conduits of the bipolar plate and thereby can produce heat upon absorption of the working fluid, hydrogen. The heat exchange conduits **76**, **76'** enable a heat transfer fluid **82** to carry heat generate by the metal hydride away from the electrochemical cell. As shown in FIG. **22**, a heat exchange port **72** may be configured through the bipolar plate to allow a heat transfer fluid to pass therethrough. FIG. **22** also shows a fuel port **73**, for supplying hydrogen to the electrochemical cell **16**.

[0122] Referring now to FIG. 23, an exemplary integrated electrochemical compressor and metal hydride heat exchanger 17 has a heat transfer fluid conduit 76 in thermal communication with the metal hydride reservoir 40. A first heat exchange conduit 76 may extend on the anode side of the cell and a second conduit may extend only on the cathode side of the cell stack 20 and a second heat exchange conduit 76 may extend on the cathode side of the cell. A heat conduit may extend over a plurality of the electrochemical cells 16, or down over the electrochemical stack. One heat exchange conduit may extend over the cells that are absorbing hydrogen and releasing heat, while the other may extend over, or be in thermal communication, with the cells that are desorbing hydrogen and conducting heat. A heat exchange conduit may extend from one side of a cell, the anode side, to a cathode side, especially when there are two or more cells, or a cell stack 20. Since the metal hydride reservoirs alternate between hot and cold, it is possible that a bipolar plate could be hot on one side and cold on another. It is therefore preferable for adjacent cells to alternate in polarity so that two hot sides, or two cathodes, are always adjacent to each other and the bipolar plate, as show in FIG. 24. Also, it is preferable that the plumbing of the heat exchange fluid alternate between adjacent cells so that it can draw the cool and hot side thermal transfers separately.

[0123] As shown in FIG. 24, two electrochemical cells 16, 16' are configured in a cell stack 20, wherein the two cathodes 32, 32', are configured adjacent each other with a heat exchange conduit 76 extending therebetween. The anodes 30, 30' are configured on the outside of the cell stack 20 and they may have another anode facing each of them. This alternating configuration simplifies plumbing and puts the exothermic sides of adjacent cells, the cathodes, adjacent each other and the endothermic sides, the anodes, adjacent each other.

[0124] FIG. 25 shows a diagram of an exemplary simplified end plate 89 for an exemplary electrochemical heat transfer device. A user may only need to connect a hot and cold heat exchanger to the heat exchange ports 72. There may be an inlet and outlet 72, 72' and 72'', 72''', respectively, for a hot and cold heat exchange fluid. A user may also connect and hydrogen source to the hydrogen feed port 73. As shown in FIG. 24, two heat exchanger connections are configured on a single end plate, one hot, 72, 72' for the inlet and outlet, and one cold, 72'', 72''', for the inlet and outlet. A first heat exchanger connection provides flow of a heat exchanger fluid that carries heat from the electrochemical cell and second heat exchanger connection provides flow of a heat exchanger fluid that carries heat to the electrochemical cell. Cells can be back ported, side ported or ported internally. In addition, the end plate could be designed so that from the users' perspective they only have to connect a plug and the hot and cold lines to protruding fittings; with all controls etc. embedded in the plate.

[0125] Metal Hydrides used within these configurations can be tailored for specific end uses, however, as an illustration, for heating water (hybrid hot water systems), La Ni_{4.7}Sn_{0.3} maybe employed with a low temperature portion (TL) of 25 C, and a high temperature portion (TH) of 80 C; and a PL 0.31 Atm, and PH 3.03 (i.e. a compression ratio of 10× roughly for maximum thermal exchange). And also as an illustration, for Cooling applications such as HVAC, or Freezers, TiCr or VTi combinations such as Ti_{0.9}Zr_{0.2}CrMn

may be employed with TL-20 C, TH 50 PL3.95 PH49.69 (i.e. a compression ratio of 10× roughly for maximum thermal exchange).

[0126] Also, to improve thermal exchange, the metal hydride beds could be made very thin, and designed for high surface area availability in wave like patterns, or pressed into plates that already have good thermal exchange designs configured on their surfaces. Those skilled in the art understand this method, and variations of this art are well established that can increase absorption rates and improve thermal transfer.

[0127] In order to minimize thermal bleed, it may be useful to separate metal hydride chambers being cycled as far as possible from each other. In the illustration above, the hydride beds are placed at opposite ends of the stack, or within the bipolar plate. However, plumbing could be adjusted to place the hydride chambers on each side of the stack (i.e. through the length of the stack). If the compressor cells are made long and thin (as is useful for maximizing current density under low anode pressure conditions or for aesthetic properties), then the metal hydride chambers can be place along the side of the stack—to create an essentially long and narrow system. This may have utility in certain installations. It would be the equivalent of for example flat screen TV's versus old tube style TV sets. Thus we are claiming stacks that are designed with cells that are longer in one dimension than another (i.e. long and narrow), and the placement of flat hydride systems adjacent to the stack so that the whole device is essentially long and narrow i.e. 'flat'!

[0128] These systems have been tested in our labs for a number of appliance applications, such as for example hybrid hot water heaters. The Metal hydride units get hot very quickly, and as a result do not suffer from the limitations of current heat pumps used in hot water systems that heat up slowly, and require the use of additional heating capacity in the form of resistance heaters. ECC driven metal hydride heat exchangers can eliminate the resistance heaters in hot water systems.

[0129] Also, because ECC units run more efficiently at partial load, they can be modulated to operate in a more efficient mode by intelligent use (and signaling). This may be particularly useful when hot water systems are used for thermal storage for utility load management (demand responsiveness). Units can be controlled remotely, and be integrated into communication protocols common with 'smart homes' and 'smart grids'. We are claiming integration of these units into such systems. And intelligent operation of these systems with these systems at partial load.

[0130] Depending on the membrane employed in the ECC, and the metal hydride heat exchange system engaged, it may be necessary to strategically place heaters within the system to pre-heat surfaces and enable operation i.e. ion exchange in high temperature membranes, or hydrogen release from metal hydride systems. We are also therefore claiming the use of heaters in the system.

[0131] Separately, it has been well established that the Nernst Equation can be a source of power generation when there is a pressure difference across an ion exchange medium. Hydrogen pressure can be generated by heating the metal hydride (with bound Hydrogen) and power generated—by essentially running the unit in reverse. This may be a useful feature of this technology, and useable in emergency

situations. This may also be connected to the smart home or smart grid management systems.

[0132] Electrochemical Compression Devices can be constructed in different ways. In one embodiment, a nickel metal hydride battery system is modified to include a metal hydride system that is suitable for heat pumping applications. This may for example include a metal hydride component customized to the application in hand, but for this preferred embodiment compound 18 i.e. a MmNi_{4.85}Fe_{0.85} powder is engaged with additives to aid production and long-term performance (such as ptfe dispersion, carbon black). The metal hydride is charged with hydrogen for heating, and the resulting heat is withdrawn by the air passage on the metal hydride heat exchanger. The unit is then allowed to return back to room temperature and the hydrogen is converted back to nickel hydroxide i.e. the other electrode reaction (as is typical in Nickel Metal Hydride cells).

[0133] In another embodiment, two metal hydride heat exchangers are engaged with a reversible electrochemical compressor between them. The metal hydride heat exchangers are then sequentially heated and cooled, and again, air passes over those heat exchange surfaces sequentially to draw heat into the cabin.

[0134] The control system can be designed for the specific Metal Hydride/Electrochemical compressor system engaged. Those skilled in the art can associate a control system to suit.

[0135] The International Journal Of Hydrogen Energy 39 (2014) page 5820, Table: 1-Equilibrium Characteristics of the interaction of hydride-forming alloys suitable for H₂

compression with H₂ gas in plateau region, is hereby incorporated by reference herein, and provided as Table 1 and Table 2.

TABLE 1

Hydride	Delta H, cal/mol	DeltaS, cal/mol-K	mc, g/mole
V _{0.95} Cr _{0.05}	-8930	-33.3	109.8
V _{0.925} Cr _{0.075}	-8680	-33.4	128.3
V _{0.9} Cr _{0.1}	-7970	-32.0	120.9
NiZr	-7270	-17.1	112.0
V _{0.85} Cr _{0.15}	-7100	-30.0	347.3
Mn _{4.5} Al _{0.46} Fe _{0.05}	-7420	-26.5	290.0
LaNi ₅	-7380	-25.8	175.8
Fe _{0.85} Mn _{0.15} Ti	-7040	-25.6	220.0
PrNi ₅	-6940	-28.5	220.0
MN _{4.5} Al _{0.05}	-6700	-25.2	281.2
FeTi	-6700	-25.3	242.2
NdNi ₅	-6650	-27.8	167.8
MNi _{4.15} Fe _{0.85}	-6000	-25.0	308.4
Zr(Fe _{0.75} Cr _{0.25}) ₂	-5920	-21.9	206.2
Ca _{0.7} Mn _{0.3} Ni ₅	-6400	-24.0	168.8
Ca _{0.5} Mn _{0.5} Ni ₅	-6160	-24.8	168.8
Ca _{0.4} Mn _{0.6} Ni ₅	-6040	-25.2	168.8
Ca _{0.2} Mn _{0.8} Ni ₅	-5800	-26.0	168.8
Ce _{0.5} La _{0.5} Ni _{2.5} Cu _{2.5}	-5500	-20.7	393.0
CeNi ₅	-5300	-26.7	198.5
CeNi _{4.5} Al _{0.5}	-5230	-220.0	220.1
MNi ₅	-5000	-23.1	203.1
ZrMn ₂ Cu _{0.8}	-6170	-13.8	175.0
ZrMn _{3.8}	-4710	-14.7	200.0
ZrMn _{2.8}	-4400	-12.5	200.0
Zr _{0.8} Ti _{0.2} MnFe	-2660	-9.4	175.0

TABLE 2

Alloy Used	Type	Mass (kg)	Capacity (kW)	COP
LaNi ₅ /MmNi _{4.15} Fe _{0.85}	R	3.6	0.6	—
LaNi _{4.7} Al _{0.3} /MmNi _{4.15} Fe _{0.85}	R	3.6	0.6	—
LaNi _{4.7} Al _{0.3} /LaNi _{4.85} Al _{0.15}	R	90	—	0.42
LaNi _{4.65} Al _{0.35} /MmNi ₄ Fe	R	40	1.75	—
LaNi _{4.65} Al _{0.35} /MmNi ₄ Fe	R	40	1.3	0.3
LaNi _{4.7} Al _{0.3} /MmNi _{4.15} Fe _{0.85}	R	90	22.8	—
LaNi ₅ /LaNi _{4.7} Al _{0.3}	HP	20	0.6	—
LaNi _{4.7} Al _{0.3} /MmNi _{4.65} Fe _{0.35}	HP	1	—	—
MmNiMnAl/MmNiMnCo	HP	64	3	—
MmNi _{4.4} Mn _{0.5} Al _{0.05} Co _{0.05}	R	48	4.6	—
MmNi _{4.7} Mn _{0.15} Lm _{0.95} Ni ₅				
LaNi _{4.5} Al _{0.5} /(CFM)Ni ₅	R	2.6	—	0.33
Zr _{0.9} Ti _{0.1} Cr _{0.9} Fe _{1.1} /Zr _{0.9} Ti _{0.1} Cr _{0.6} Fe _{1.4}	R	4.5	0.683	—
Program control	R	1.5	0.1	0.2-0.4
LaNi _{4.7} Al _{0.3} /MmNi _{4.15} Fe _{0.85}	R	—	—	—
LaNi _{4.6} Al _{0.3} /MmNi _{4.85} Fe _{0.15}	HP	3	0.15-0.2	0.17-0.2
LaNi ₅	C	1	1.5 (150 s cooling)	—
Ca _{0.4} Mm _{0.6} Ni ₅	C	1	—	—
LaNi _{4.6} Al _{0.4}	R	3	2.2 (150 s cooling)	—
MmNi _{4.15} Fe _{0.85}				
Zr _{0.9} Ti _{0.1} Cr _{0.55} Fe _{1.45}	C	1	0.41	1.8

[0136] As shown in FIG. 26, a furnishing 100 incorporates a furnishing temperature control system 110 employing an electrochemical heat transfer device 10, as described herein. In this exemplary embodiment, a first reservoir 40 and a second reservoir 50 are configured within the seat 102, in this case a vehicle seat 102. A set of conduits 27 forms a closed loop from the first reservoir to the second reservoir. The electrochemical heat transfer device may be any of those as describe herein including those shown in FIGS. 10, 15 to 18, and 20 to 25.

[0137] As shown in FIG. 27, a vehicle seat 104 has a first electrochemical heat transfer device 10 and a second electrochemical heat transfer device 10', each having a first reservoir 40 and a second reservoir 50. The two heat transfer devices may control the temperature of the furnishing. Each of the electrochemical heat transfer devices has a heat exchanger 47, 47' for transferring of heat between the furnishing and the reservoir.

[0138] Those of skill in the art will also appreciate that the seat control module can comprise a hard-wired feedback control circuit, a dedicated processor or any other control device that can be constructed for performing the steps and functions described herein. In addition, the controller within the control module may be combined or divided into sub-components as deemed appropriate. For example, it may be advantageous to divide the control module into a first module for conditioning the backrest portion and a second control module for conditioning the seat portion. In another embodiment, separate control modules may be provided for the thermal elements and the fluid modules. In addition, it should be appreciated that the control system represents only one exemplary arrangement of a system for controlling the operation of the climate control system. Those of skill in the art will recognize in light of the disclosure herein various other configurations for the control system. In addition, one or more components of the control module may be located in various locations, such as, within one or both of the fluid modules or in a separate location.

[0139] Various components are described as being “operatively connected” to the control unit. It should be appreciated that this is a broad term that includes physical connections (e.g., electrical wires or hard wire circuits) and non-physical connections (e.g., radio or infrared signals). It should also be appreciated that “operatively connected” includes direct connections and indirect connections (e.g., through additional intermediate device(s)).

[0140] The control module optionally may also be configured to receive a signal from a vehicle control device that indicates whether the vehicle's ignition has been turned on. In this manner, the seat control module may be configured to allow operation of the system only if the vehicle's engine is running.

[0141] In one embodiment, the thermal elements are activated to heat the surfaces of the backrest portion and seat portion. While the thermal elements are activated, the fluid modules can provide a fluid flow to the surfaces of the backrest portion and seat portion. The fluid may be unconditioned (e.g., not heated) and in such an embodiment the fluid can enhance the thermal elements by promoting convection of heat from the thermal elements to the surfaces of the backrest portion and seat portion. In another embodiment, while the electrochemical device(s) are activated, the fluid modules provide heated air to the surfaces of the backrest portion and seat portion. In this manner, the fluid

modules supplement and enhance the heating effect provided by the thermal elements. In yet another embodiment, the thermal elements are used during a first or initial period of time to heat the surfaces of the backrest portion and seat portion largely through conduction. After the first or initial period of time, the fluid modules can provide conditioned or un-conditioned air to the surfaces of the backrest portion and seat portion.

[0142] The above described embodiments have several advantages. For example, in particularly cold conditions, it may take a long period of time to heat noticeably the seat assembly using heated air provided by the fluid modules alone. In the above described embodiment, because the thermal elements are positioned near the surfaces of the backrest portion and seat portion, they can provide immediate heat via conduction that can be sensed by the occupant of the seat assembly. The air provided through the distribution system can enhance (e.g., through convection) or supplement (e.g., by providing conditioned air) the heat provided by the thermal elements.

[0143] While various embodiments and modes of operation have been described above, it is anticipated that the different portions of the seat assembly (e.g., seat and backrest portions) may be controlled in modified manners and/or controlled to different temperature settings.

[0144] In this embodiment, the heating elements are positioned generally within or proximate to the distribution passages as formed by the channels and/or through passages, which are used to transport air through the seat assembly. In addition, the distribution system of this embodiment does not include an insert. However, as mentioned above, it should be appreciated that certain components and features of the distribution systems for the seat and cushion portions may be exchanged and/or combined. For example, the seat portion may include an insert and/or the thermal elements can be positioned within the scrim. In addition, it should be appreciated that in a modified embodiment one or more thermal elements (not shown) can be provided near or adjacent the top surface of the seat. In such an embodiment, the thermal elements can be provided within the scrim.

[0145] Although the foregoing description of the preferred embodiments has shown, described, and pointed out certain novel features, it will be understood that various omissions, substitutions, and changes in the form of the detail of the apparatus as illustrated, as well as the uses thereof, may be made by those skilled in the art without departing from the spirit of this disclosure. Consequently, the scope of the present invention should not be limited by the foregoing discussion, which is intended to illustrate rather than limit the scope of the invention.

[0146] It will be apparent to those skilled in the art that various modifications, combinations and variations can be made in the present invention without departing from the spirit or scope of the invention. Specific embodiments, features and elements described herein may be modified, and/or combined in any suitable manner. Thus, it is intended that the present invention cover the modifications, combinations and variations of this invention provided they come within the scope of the appended claims and their equivalents.

What is claimed is:

1. A furnishing temperature control system employing an electrochemical heat transfer device comprising:
 - a) a furnishing;
 - b) a controller;

- c) a working fluid comprising hydrogen;
 - d) a first electrochemical hydrogen compressor comprising:
 - i) an anode;
 - ii) a cathode;
 - iii) a proton exchange membrane;
 - iv) a power supply coupled to the anode and cathode to create an electrical potential across the anode and cathode to transfer the hydrogen across the proton exchange membrane from the anode to the cathode;
 - e) a first reservoir comprising metal hydride forming alloy;
 - f) a first heat transfer device coupled to said first reservoir and coupled to said furnishing;
 - wherein the electrochemical heat transfer device controls a temperature of a furnishing.
2. The furnishing temperature control system employing an electrochemical heat transfer device of claim 1, wherein the controller switches the electrical potential of the power source to switch the anode to the cathode and the cathode to the anode, wherein the electrochemical hydrogen compressor transfers hydrogen to said first reservoir and wherein hydrogen is absorbed to the metal hydride and heat is transferred from said first reservoir to the heat exchange device and wherein heat is transferred from the heat exchanger to the furnishing and wherein the electrochemical heat transfer device is a heating device and heats the furnishing.
3. The furnishing temperature control system employing an electrochemical heat transfer device of claim 1, wherein the controller switches the electrical potential of the power source to switch the anode to the cathode and the cathode to the anode, wherein the electrochemical hydrogen compressor transfers hydrogen from said first reservoir and wherein hydrogen is desorbed from the metal hydride and heat is transferred from said first reservoir to the heat exchange device and wherein heat is transferred from the furnishing to the heat exchanger and wherein the electrochemical heat transfer device is a cooling device and cools the furnishing.
4. The furnishing temperature control system employing an electrochemical heat transfer device of claim 3, wherein the controller switches the electrical potential of the power source to switch the anode to the cathode and the cathode to the anode, wherein the electrochemical hydrogen compressor transfers hydrogen to said first reservoir and wherein hydrogen is absorbed to the metal hydride and heat is transferred from said first reservoir to the heat exchange device and wherein heat is transferred from the heat exchanger to the furnishing and wherein the electrochemical heat transfer device is a heating device and a cooling device and both heats and cools the furnishing.
5. The furnishing temperature control system employing an electrochemical heat transfer device of claim 1, wherein the working fluid consists essentially of hydrogen.
6. The furnishing temperature control system employing an electrochemical heat transfer device of claim 1, wherein the proton exchange membrane comprises per-fluorosulfonic acid.
7. The furnishing temperature control system employing an electrochemical heat transfer device of claim 1, wherein the proton exchange membrane comprises a desiccant.
8. The furnishing temperature control system employing an electrochemical heat transfer device of claim 1, wherein

the heat transfer device comprises a heat exchange conduit and wherein a heat transfer fluid flows through said heat exchange conduit.

9. The furnishing temperature control system employing an electrochemical heat transfer device of claim 1, further comprising:

- a) a second reservoir comprising a metal hydride forming alloy,
- b) a second heat exchange device coupled to the said second reservoir;
- c) set of conduits to fluidly connecting the first electrochemical hydrogen compressor with the first heat transfer device the second heat transfer device;

wherein the electrochemical hydrogen compressor transfers hydrogen from said first reservoir to the second reservoir and wherein hydrogen is desorbed from the metal hydride in said first reservoir and wherein hydrogen is absorbed by the metal hydride in said second reservoir,

wherein heat is transferred between the first heat exchange device and said first reservoir and wherein heat is transferred between the second reservoir and the second heat exchange device.

10. The furnishing temperature control system employing an electrochemical heat transfer device of claim 9, wherein at least one of the first or second reservoirs comprise a desiccant.

11. The furnishing temperature control system employing an electrochemical heat transfer device of claim 9, further comprising a desiccant unit that is coupled with the set of conduits to receive the working fluid and remove moisture.

12. The furnishing temperature control system employing an electrochemical heat transfer device of claim 11, comprising a desiccant bypass valve;

wherein when the desiccant bypass valve is open, the working fluid bypasses the desiccant unit, and

wherein when the desiccant bypass valve is closed, the working fluid enters into the desiccant unit to remove moisture from the working fluid.

13. The furnishing temperature control system employing an electrochemical heat transfer device of claim 9, wherein the set of conduits forms a closed loop of conduits coupling the first reservoir with the first and second electrochemical hydrogen compressors and the second reservoir with the first and second electrochemical hydrogen compressor;

wherein the working fluid is configured to flow from the first reservoir through the first electrochemical hydrogen compressor to the second reservoir and subsequently from the second reservoir through the second electrochemical hydrogen compressor back to the first reservoir.

14. The furnishing temperature control system employing an electrochemical heat transfer device of claim 9, comprising:

- a) a closed loop of conduits formed from said set of conduits and coupling the first reservoir with the first and second electrochemical hydrogen compressors and the second reservoir with the first and second electrochemical hydrogen compressor;

wherein the closed loop of conduits has an outlet portion of the closed loop and an inlet portion of the closed loop;

- i) wherein the outlet portion of the closed loop is fluidly coupled with the cathode of the first electrochemical hydrogen compressor, and with the first and second electrochemical hydrogen compressor;
- ii) wherein the inlet portion of the closed loop is fluidly coupled with the anode of the first electrochemical hydrogen compressor,
- b) a plurality of valves in the closed loop of conduits wherein there is a valve between the first electrochemical hydrogen compressor and the first and second reservoirs on both the outlet portion and inlet portion;
 - i) wherein a first outlet portion valve is configured between the first electrochemical hydrogen compressor and the first reservoir on the outlet portion of the closed loop;
 - ii) wherein a second outlet portion valve is configured between the first electrochemical hydrogen compressor and the second reservoir on the outlet portion of the closed loop;
 - iii) wherein a first inlet portion valve is configured between the first electrochemical hydrogen compressor and the first reservoir on the inlet portion of the closed loop;
 - iv) wherein a second inlet portion valve is configured between the first electrochemical hydrogen compressor and the second reservoir on the inlet portion of the closed loop;

wherein the working fluid is configured to flow from the first reservoir through the first electrochemical hydrogen compressor to the second reservoir and subsequently from the second reservoir through the first electrochemical hydrogen compressor back to the first reservoir.

15. The furnishing temperature control system of claim **14**, wherein the furnishing is a seat and wherein the heat transfer device comprises a heat transfer conduit in thermal communication with the first reservoir and wherein a heat transfer fluid flows through the heat transfer conduit to transfer heat from the first reservoir to the seat.

16. The furnishing temperature control system of claim **1**, wherein the proton exchange membrane comprises phosphoric acid-functionalized polybenzimidazole/polytetrafluoroethylene.

17. The furnishing temperature control system of claim **1**, wherein the metal hydride forming alloy comprises a packed bed of metal hydride forming alloy.

18. The furnishing temperature control system of claim **1**, wherein the furnishing is a seat.

19. The furnishing temperature control system of claim **18**, wherein the furnishing is a vehicle seat.

20. The furnishing temperature control system of claim **18**, wherein the furnishing is a vehicle seat and wherein the heat transfer device comprises a heat transfer conduit in thermal communication with the first reservoir and wherein a heat transfer fluid flows through the heat transfer conduit to transfer heat from the first reservoir to the vehicle seat.

* * * * *