



US 20170326283A1

(19) **United States**

(12) **Patent Application Publication**
Schade et al.

(10) **Pub. No.: US 2017/0326283 A1**

(43) **Pub. Date: Nov. 16, 2017**

(54) **SYSTEMS FOR LVAD OPERATION DURING COMMUNICATION LOSSES**

Publication Classification

(71) Applicant: **TC1 LLC**, St. Paul, MN (US)

(51) **Int. Cl.**
A61M 1/10 (2006.01)
A61M 1/10 (2006.01)
A61M 1/12 (2006.01)

(72) Inventors: **Christian Schade**, Feldmeilen (CH);
Andre Siebenhaar, Gipf-Oberfrick (CH)

(52) **U.S. Cl.**
CPC *A61M 1/1086* (2013.01); *A61M 1/122* (2014.02); *A61M 1/1036* (2014.02); *A61M 2205/16* (2013.01)

(21) Appl. No.: **15/651,875**

(57) **ABSTRACT**

(22) Filed: **Jul. 17, 2017**

Systems and devices for an adaptable blood pump are disclosed herein. The blood pump can be part of a mechanical circulatory support system that can include a system controller and the blood pump. The blood pump can include a rotary motor and a control unit that can communicate with the system controller. The blood pump can determine when communication with the system controller is established or has been lost. The blood pump can retrieve one or several back-up parameters when communication with the system controller has been lost, and can operate according to these back-up parameters.

Related U.S. Application Data

(62) Division of application No. 14/687,817, filed on Apr. 15, 2015, now Pat. No. 9,744,280.

(60) Provisional application No. 61/979,803, filed on Apr. 15, 2014.

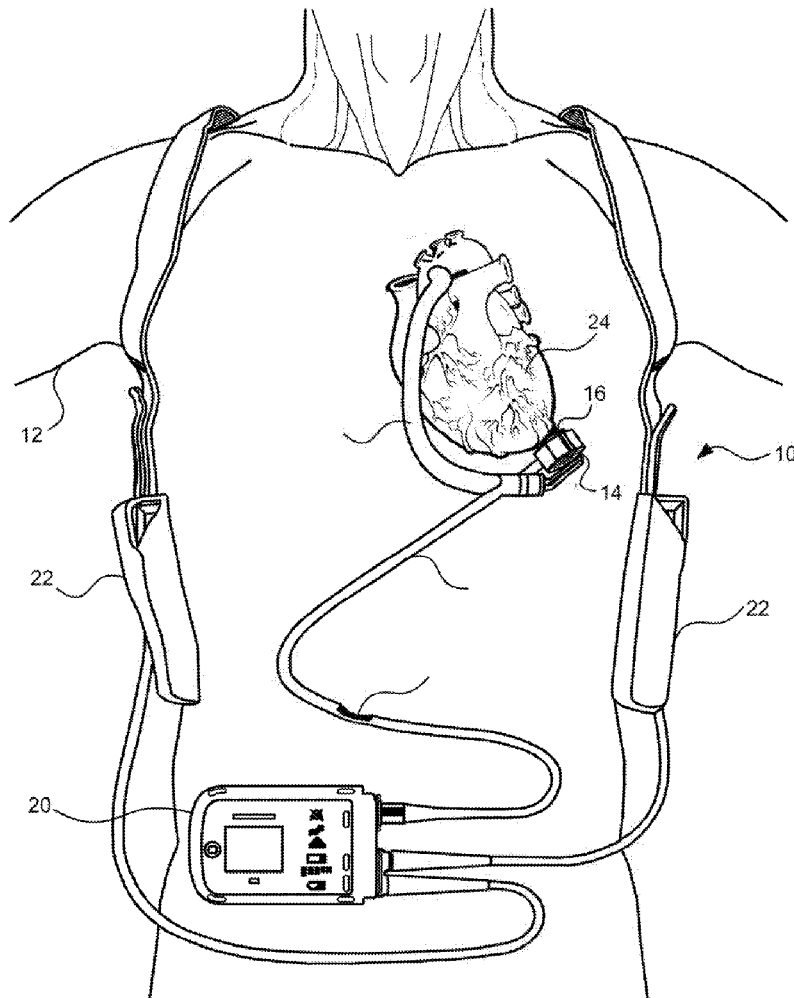

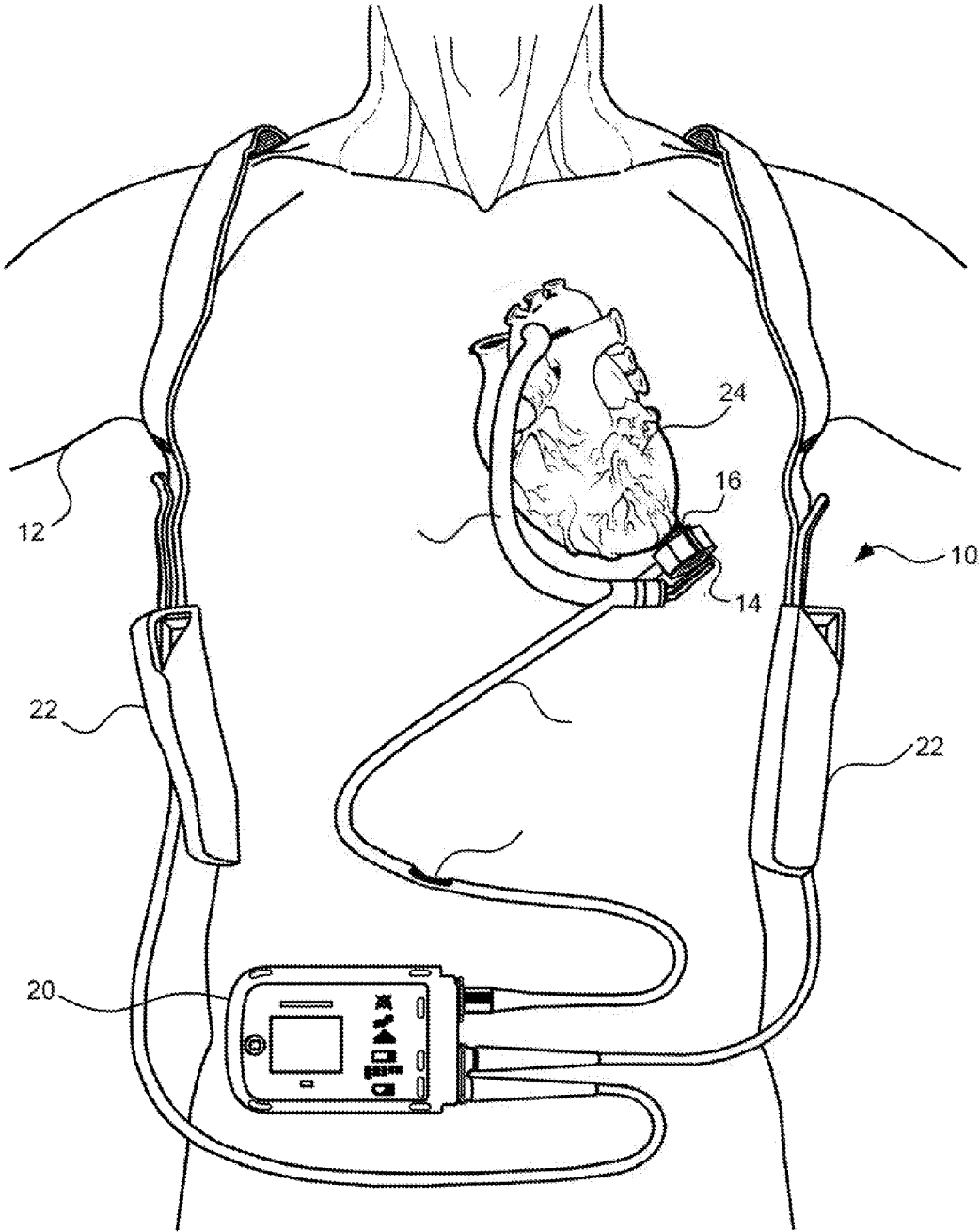

FIG. 1

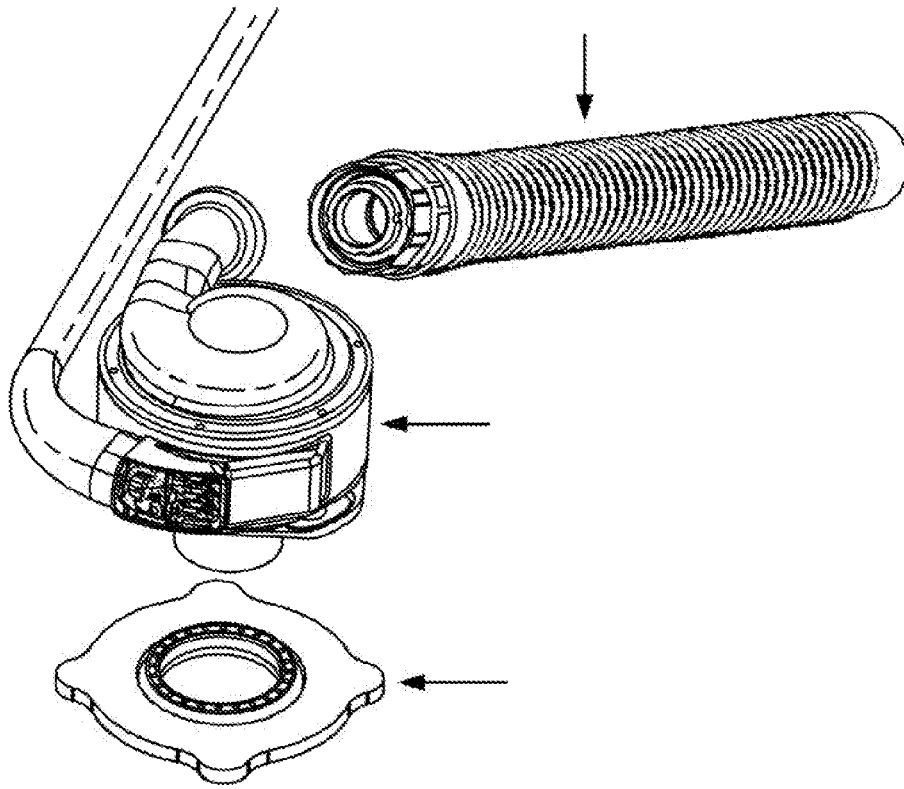

FIG. 2

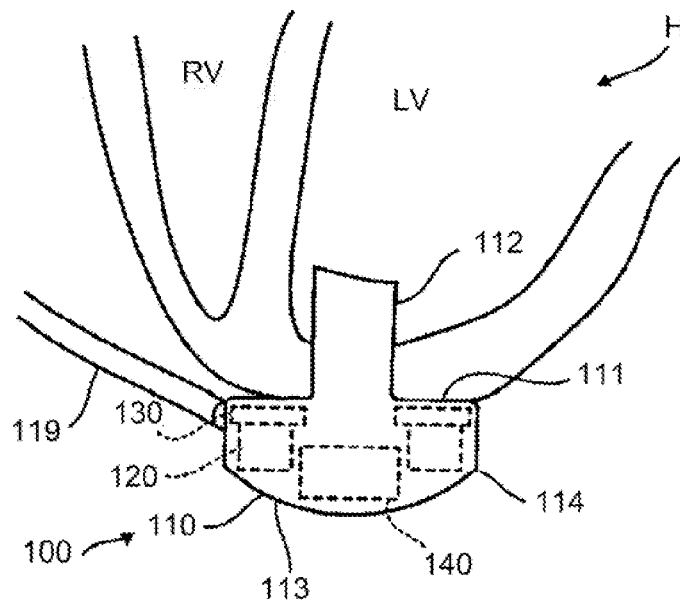

FIG. 3

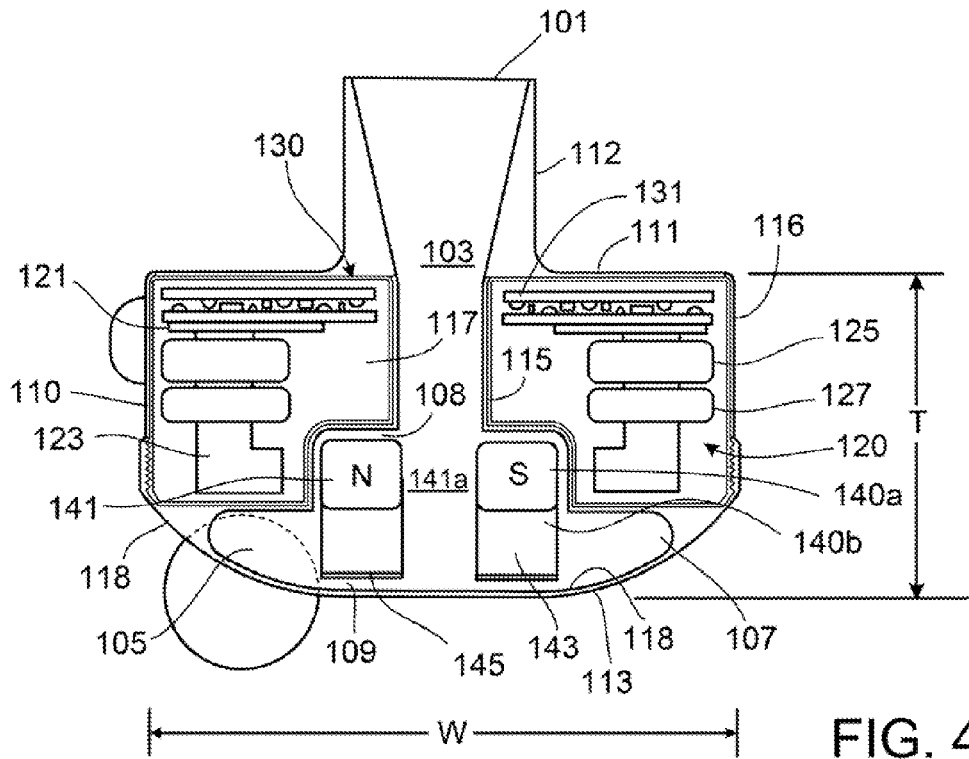

FIG. 4

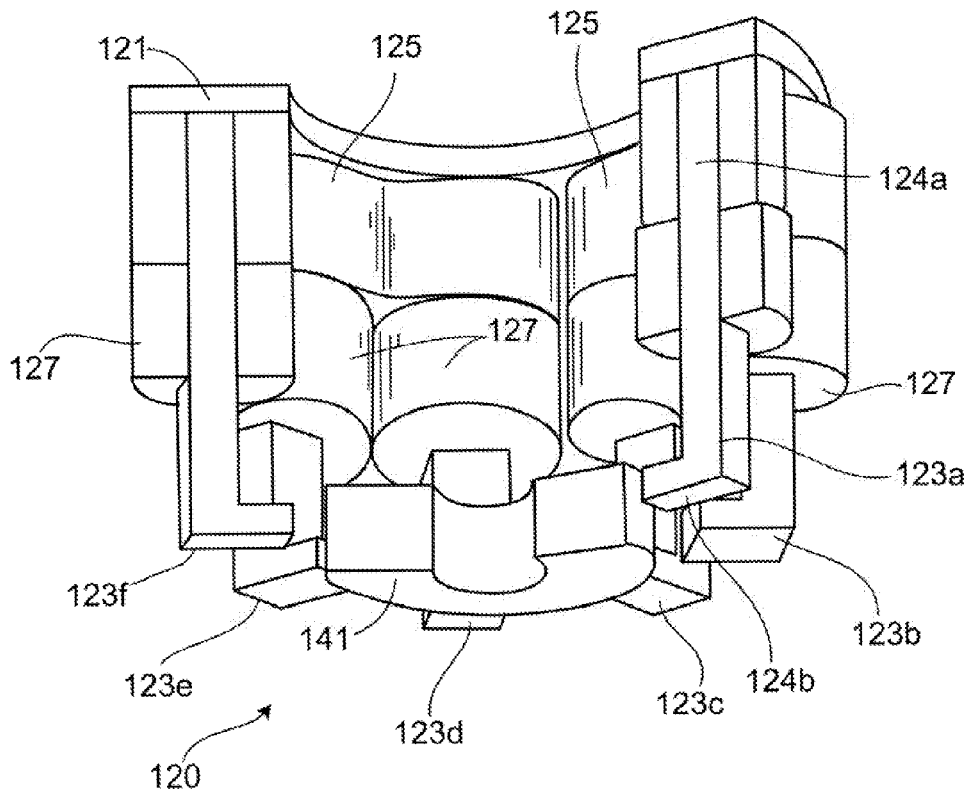

FIG. 5

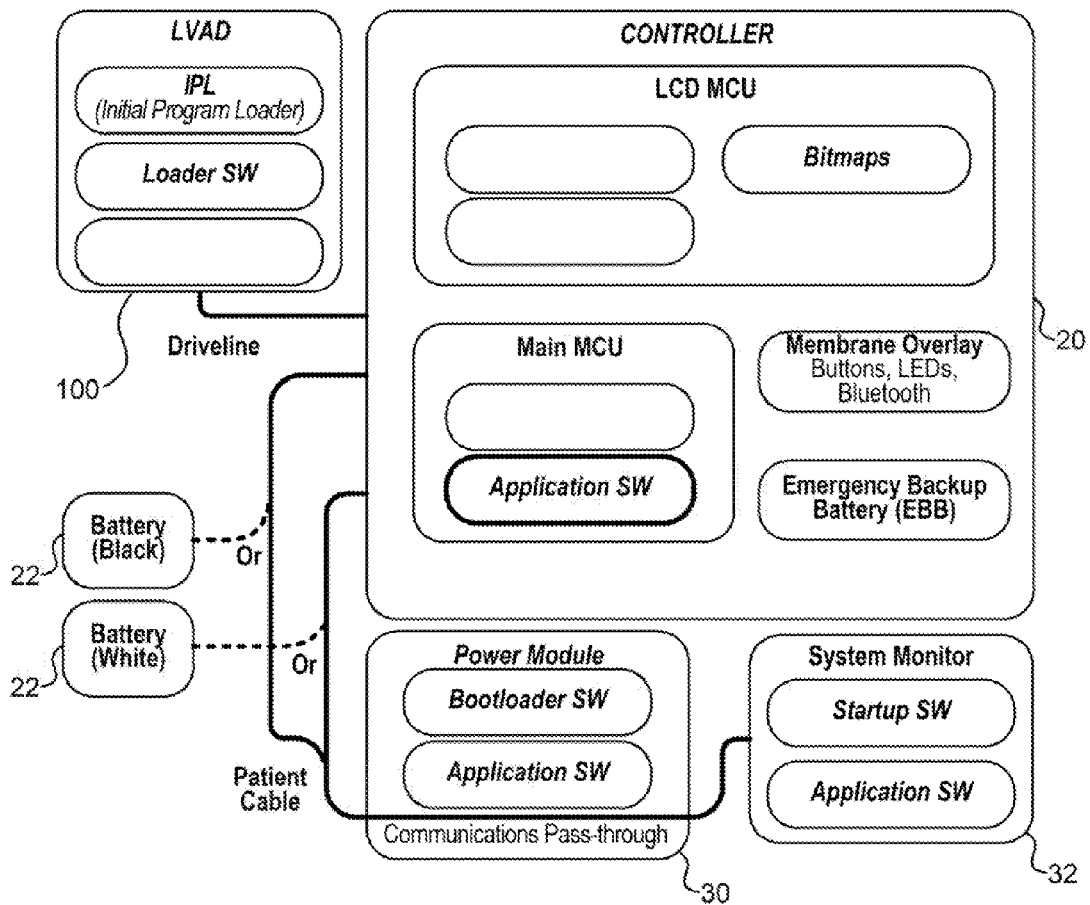

FIG. 6

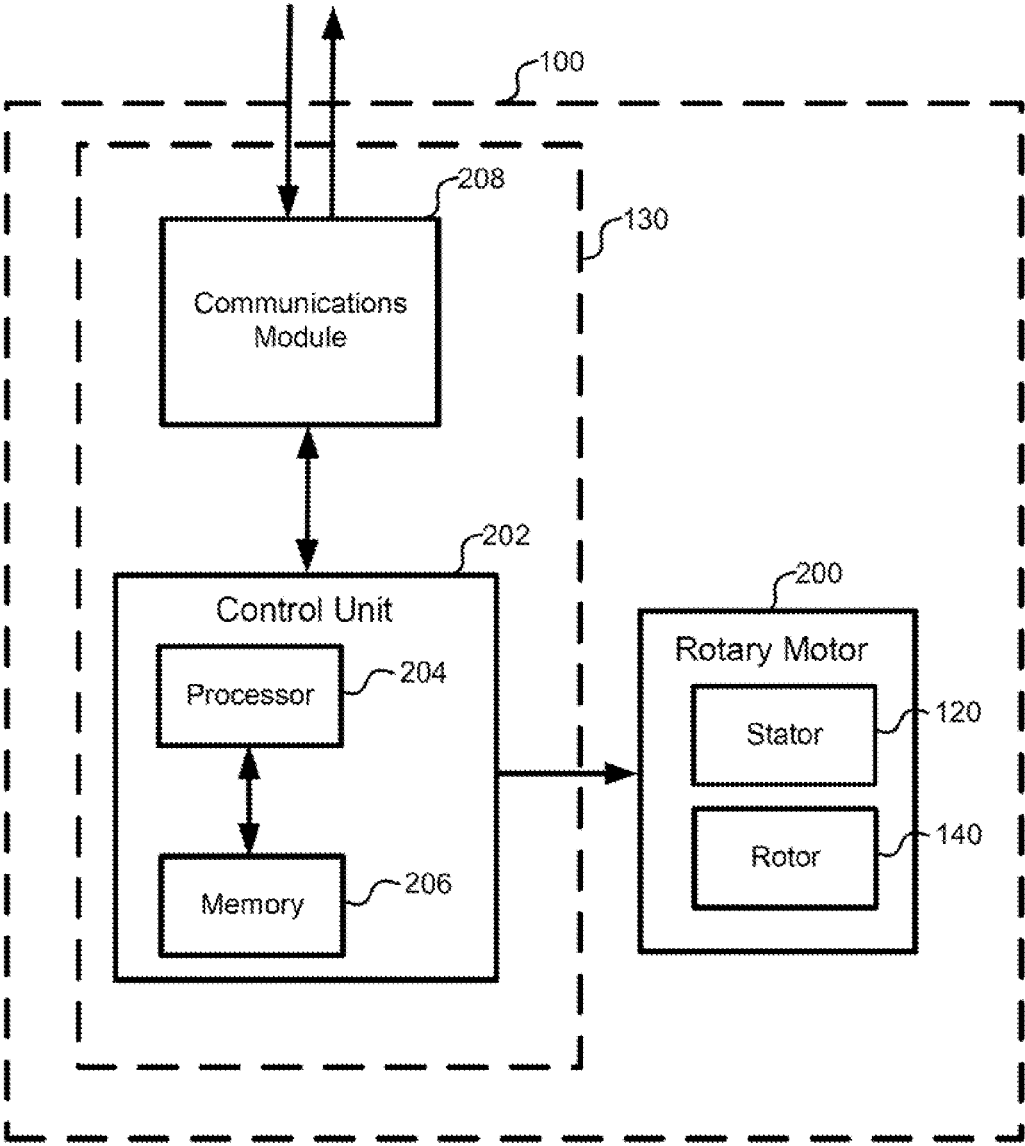

Fig. 7

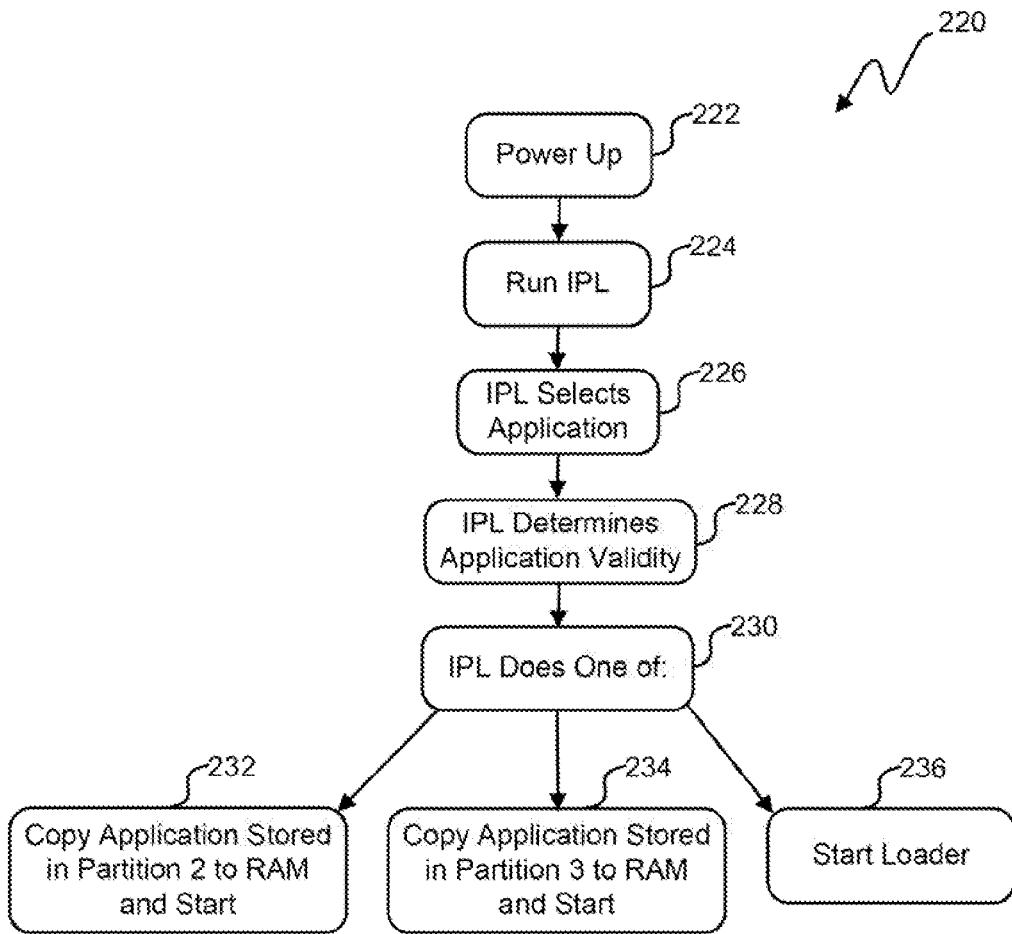

Fig. 8

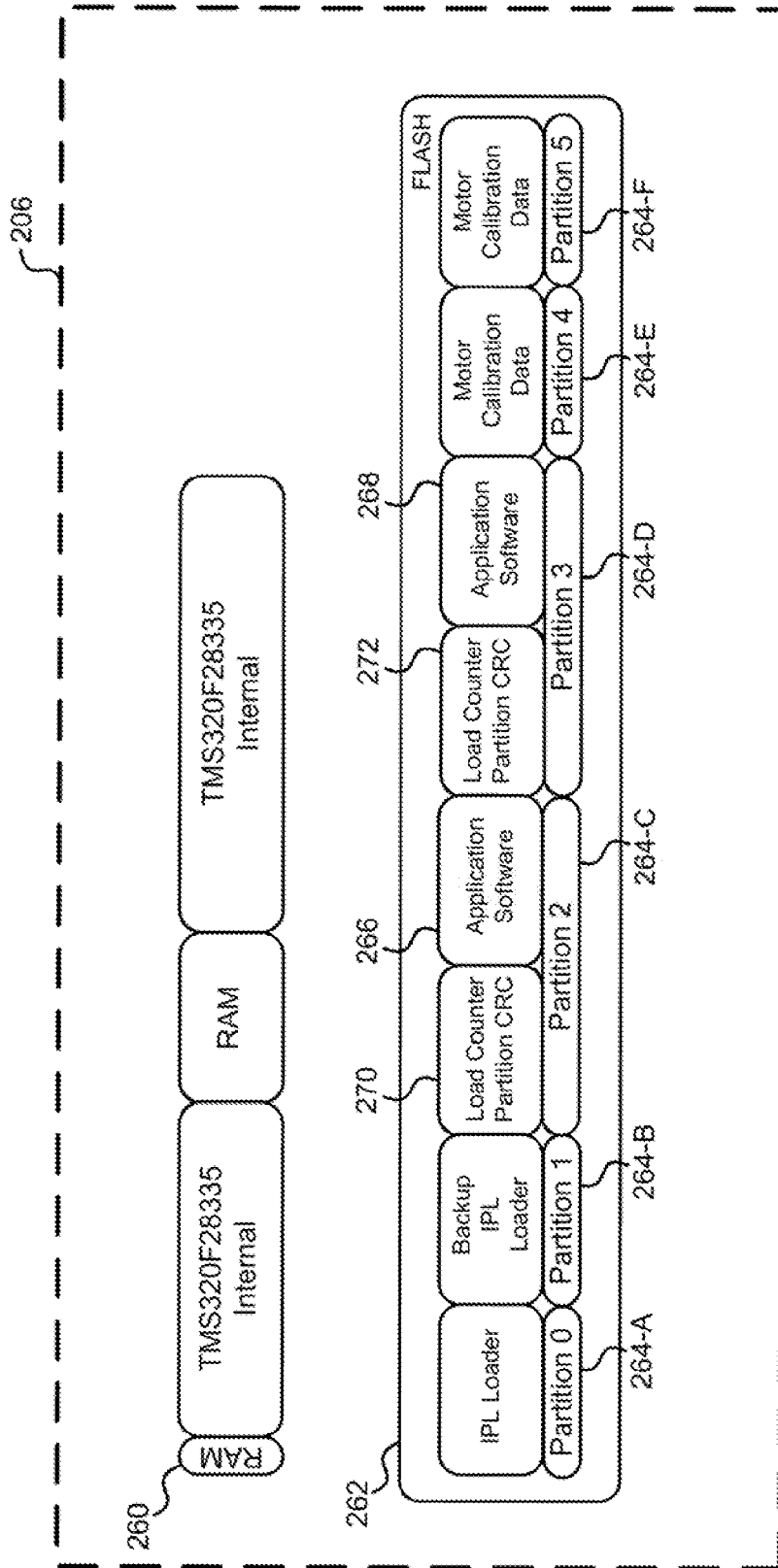

Fig. 9

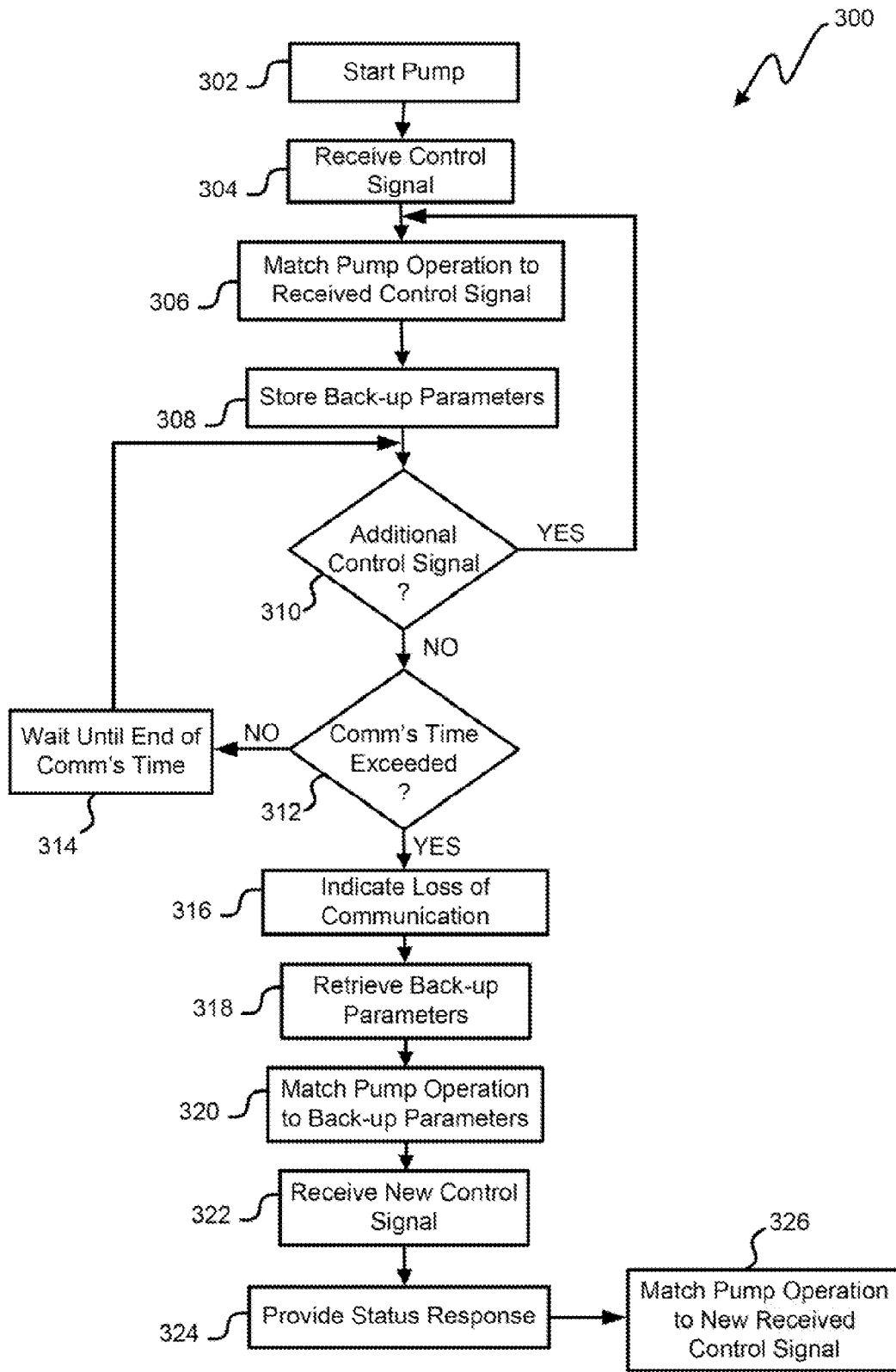

Fig. 10

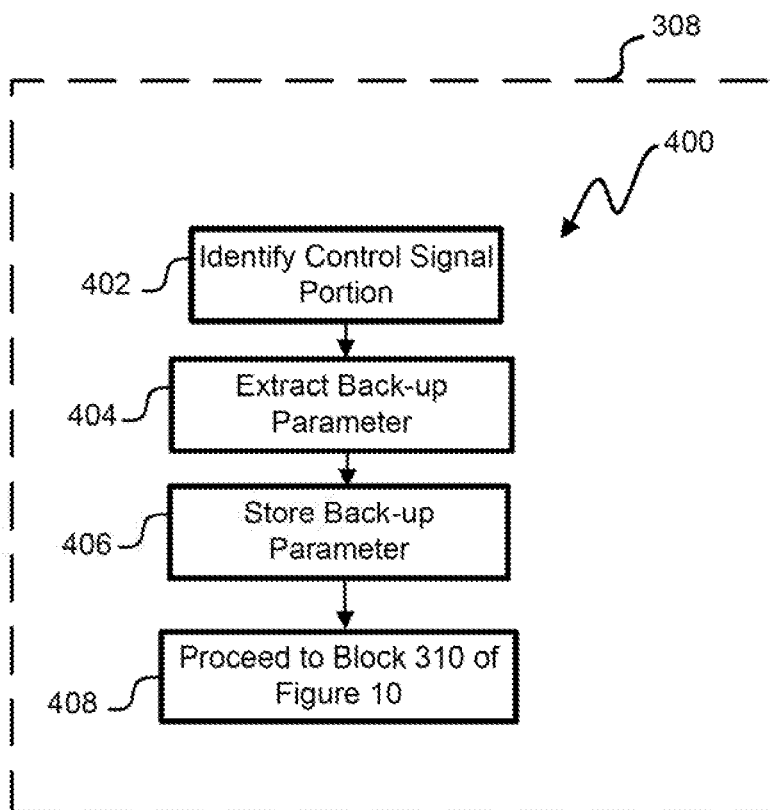

Fig. 11

SYSTEMS FOR LVAD OPERATION DURING COMMUNICATION LOSSES

CROSS-REFERENCES TO RELATED APPLICATIONS

[0001] This application is a divisional of U.S. application Ser. No. 14/687,817, filed Apr. 15, 2015, which application claims the benefit of U.S. Provisional Application No. 61/979,803 filed Apr. 15, 2014, the entire contents of which are hereby incorporated by reference in their entirety for all purposes.

BACKGROUND

[0002] This application relates generally to mechanical circulatory support systems, and more specifically relates to control systems, for an implantable blood pump.

[0003] Ventricular assist devices, known as VADs, are implantable blood pumps used for both short-term (i.e., days, months) and long-term applications (i.e., years or a lifetime) where a patient's heart is incapable of providing adequate circulation, commonly referred to as heart failure or congestive heart failure. According to the American Heart Association, more than five million Americans are living with heart failure, with about 670,000 new cases diagnosed every year. People with heart failure often have shortness of breath and fatigue. Years of living with blocked arteries or high blood pressure can leave your heart too weak to pump enough blood to your body. As symptoms worsen, advanced heart failure develops.

[0004] A patient suffering from heart failure, also called congestive heart failure, may use a VAD while awaiting a heart transplant or as a long term destination therapy. In another example, a patient may use a VAD while recovering from heart surgery. Thus, a VAD can supplement a weak heart (i.e., partial support) or can effectively replace the natural heart's function. VADs can be implanted in the patient's body and powered by an electrical power source inside or outside the patient's body.

[0005] As VAD systems continue to develop and are more widely used, the importance of reliability continues to increase. Reliability becomes particularly significant in light of the mechanical and electrical complexity of the VAD, and the interrelation and communication between the different components working with the VAD. Thus, new methods, systems, and devices that will increase the reliability of the VAD are desired.

BRIEF SUMMARY

[0006] The present invention provides new systems, methods, and devices which can advantageously allow for uninterrupted operation of pump components of the VAD without the receipt of external control signals during a communication loss or interruption. For example, the pump components of the VAD can be separately located from a portion of the system controls of the VAD. This can advantageously increase the implantability of the pump components by decreasing the size of the housing containing the pump components. When the pump components of the VAD are separately housed from a portion of the system controls, the pump components of the VAD can receive control signals from the system controls that direct the operation of the pump components. In the event that these control signals are not received, the pump components of the VAD can

operate according to one or several back-up parameters. This is clearly advantageous from the patient's perspective as this decreases the risk of a failure of the VAD due to, for example, interference with communications or a failure of the system controls. Thus, this capability increases the robustness and reliability of the VAD and in turn increases patient safety and clinical effectiveness.

[0007] One aspect of the present disclosure relates to a mechanical circulatory support system. The mechanical circulatory support system includes a controller that can generate control signals including at least one performance parameter and that can repeatedly transmit the control signals within consecutive time periods, and an implantable blood pump communicatively coupled to the controller. The blood pump can include a rotary motor and a control unit communicatively coupled with the rotary motor. The control unit can track the consecutive time periods, receive the control signals from the controller, and retrieve at least one backup parameter if a control signal is not received from the controller within a predetermined time period or within a number of the consecutive time periods. In some embodiments, this can ensure operation of the implantable blood pump during a communication interruption or loss.

[0008] In some embodiments of the mechanical circulatory support system, the control unit can control at least one of the motion and position of the rotary motor, and specifically, the control unit can control at least one of the speed, mode, or pulse parameter of the motor according to the received control signals or the at least one backup parameter. In some embodiments, the control unit can determine a current pump performance, compare the current pump performance to the at least one back-up parameter, and generate one or several control signals to achieve the pump performance specified by the at least one back-up parameter. In some embodiments, the predetermined time period can be at least 5 seconds. In some embodiments, one of the consecutive time periods can have a length of time of less than 1 second. In some embodiments, the predetermined number can be at least five consecutive time periods.

[0009] In some embodiments of the mechanical circulatory support system, the at least one performance parameter can include at least one of a pump speed, a pump operational mode, and a pulse parameter. In some embodiments, the pulse parameter can be one of a pulse duration, a systolic pressure, a diastolic pressure, and a pulse pressure. In some embodiments, the pump operational mode can be at least one of continuous flow, pulsatile pumping, or non-pulsatile mode. In some embodiments, the at least one back-up parameter can be at least one of a pump speed, pump operational mode, and a pulse parameter, and in some embodiments, the control unit can generate the at least one back-up parameter from the control signal received from the controller. In some embodiments, the control unit can include memory which can store the at least one back up parameter.

[0010] In some embodiments of the mechanical circulatory support system, the control unit, can return to operation based on control signals received from the external controller when communication is re-established. In some embodiments, the controller can include an external or implantable controller configured to wirelessly transmit the control signals. In some embodiments, the controller can include an external or implantable controller having to driveline coupled to the implantable pump to transmit the control

signals. In some embodiments, the control unit can control the mode of the rotary motor according to the received control signals or the at least one back-up parameter, and in some embodiments, the control unit can control the pulse parameter of the rotary motor according to the received control signals or the at least one back-up parameter.

[0011] One aspect of the present disclosure relates to an implantable blood pump. The implantable blood pump can include a rotary motor, and a control unit communicatively coupled with the rotary motor. The control unit can repeatedly receive control signals that can include at least one performance parameter, track receipt of the control signals over a time period, and retrieve at least one back-up parameter if a control signal is not received within a predetermined time period to ensure operation of the implantable blood pump during a communication interruption or loss.

[0012] In some embodiments of the implantable blood pump, the control unit can provide a status update in response to a received control signal. In some embodiments, the at least one back-up parameter is retrieved if a control signal is not received within the predetermined time period of five seconds. In some embodiments, the at least one performance parameter can include at least one of a pump speed, a pump operational mode, and a pulse parameter. In some embodiments, the pulse parameter can be one of a pulse duration, a systolic pressure, a diastolic pressure, and a pulse pressure, and in some embodiments, the pump operational mode can include at least one of continuous flow, pulsatile pumping, or non-pulsatile mode.

[0013] In some embodiments of the implantable blood pump, the at least one back-up parameter can include at least one of a pump speed, a pump operational mode, and a pulse parameter. In some embodiments, the control unit can return to operation based on control signals received from the controller when a new control signal is received. In some embodiments, the rotary motor can be located within a first implantable housing and the control unit can be located in a second implantable housing.

[0014] One aspect of the present disclosure relates to a method of operating an implantable blood pump. The method includes repeatedly receiving a control signal that includes at least one blood pump performance parameter, operating the blood pump according to the control signal, triggering a threshold indicating absence of receipt of a new control signal, retrieving at least one back-up parameter that includes a blood pump performance parameter, and operating the blood pump according to the at least one back-up parameter.

[0015] In some embodiments of the method, the at least one back-up parameter can be retrieved from memory located on the blood pump. In some embodiments, the threshold can be triggered when a new control signal is not received within a predetermined time period. In some embodiments, the predetermined time period can be at least 5 seconds. In some embodiments, the blood pump performance parameter can include a first portion, specifying a pump speed, and a second portion specifying a pulse parameter. In some embodiments, the method includes storing the first portion of the control signal as the at least one back-up parameter. In some embodiments, the method includes receiving a second control signal when the blood pump is operating according to the at least one back-up parameter, and operating the blood pump according to the second control signal.

BRIEF DESCRIPTION OF THE DRAWINGS

[0016] FIG. 1 is an illustration of a mechanical circulatory support system implanted in a patient's body.

[0017] FIG. 2 is an exploded view of certain components of the circulatory support system that are implanted in a patient's body.

[0018] FIG. 3 is an illustration of a blood pump in an operational position implanted in a patient's body.

[0019] FIG. 4 is a cross-sectional view of the blood pump of FIG. 3.

[0020] FIG. 5 is a partial cut-away perspective view of a stator of a blood pump.

[0021] FIG. 6 is a schematic diagram of the overall communication architecture of the mechanical support system of FIG. 1.

[0022] FIG. 7 is a schematic diagram illustrating one embodiment of a blood pump.

[0023] FIG. 8 is a flowchart illustrating one embodiment of operation of the blood pump.

[0024] FIG. 9 is a schematic illustration of some of the operations of the blood pump.

[0025] FIG. 10 is a flowchart illustrating one embodiment of a process for operation of the blood pump when communication with a system controller is lost.

[0026] FIG. 11 is a flowchart illustrating one embodiment of process for generating a back-up parameter.

DETAILED DESCRIPTION

[0027] FIG. 1 is an illustration of a mechanical circulatory support system 10 implanted in a patient's body 12. The mechanical circulatory support system 10 comprises an implantable blood pump 14, ventricular cuff 16, outflow cannula 18, system controller 20, and power sources 22, the implantable blood pump 14 may comprise a VAD that is attached to an atrium of the left ventricle, as illustrated, or the right ventricle, or both ventricles of the heart 24. The VAD may comprise a centrifugal (as shown) or axial flow pump as described in further detail herein that is capable of pumping the entire output delivered to the left ventricle from the pulmonary circulation (i.e., up to 10 liters per minute). Related blood pumps applicable to the present invention are described in greater detail below and in U.S. Pat. Nos. 5,695,471, 6,071,093, 6,116,862, 6,186,665, 6,234,772, 6,264,635, 6,688,861, 7,699,586, 7,976,271, 7,997,854, 8,007,254, 8,152,493, 8,652,024, and 8,668,473 and U.S. Patent Publication Nos. 2007/0078293, 2008/0021394, 2009/0203957, 2012/0046514, 2012/0095281, 2013/0096364, 2013/0170970, 2013/0121821, and 2013/0225909, all of which are incorporated herein by reference for all purposes in their entirety. With reference to FIGS. 1 and 2, the blood pump 14 may be attached to the heart 24 via the ventricular cuff 16 which is sewn to the heart 24 and coupled to the blood pump 14. The other end of the blood pump 14 connects to the ascending aorta via the outflow cannula 18 so that the VAD effectively diverts blood from the weakened ventricle and propels it to the aorta for circulation to the rest of the patient's vascular system.

[0028] FIG. 1 illustrates the mechanical circulatory support system 10 during battery 22 powered operation. A driveline 26 which exits through the patient's abdomen 28, connects the implanted blood pump 14 to the system controller 20, which monitors system 10 operation. Related controller systems applicable to the present invention are

described in greater detail below and in U.S. Pat. Nos. 5,888,242, 6,991,595, 8,323,174, 8,449,444, 8,506,471, 8,597,350, and 8,657,733 and U.S. Patent Publication Nos. 2005/0071001 and 2013/0314047, all of which are incorporated herein by reference for all purposes in their entirety. The system may be powered by either one, two, or more batteries 22. It will be appreciated that although the system controller 20 and power source 22 are illustrated outside/external to the patient body, the driveline 26, system controller 20 and/or power source 22 may be partially or fully implantable within the patient, as separate components or integrated with the blood pump 14. Examples of such modifications are further described in U.S. Pat. No. 8,562,508 and Patent Publication No. 2013/0127253, all of which are incorporated herein by reference for all purposes in their entirety.

[0029] With reference to FIGS. 3 to 5, a left ventricular assist blood pump 100 having a circular shaped housing 110 is implanted in a patient's body with a first face 111 of the housing 110 positioned against the patient's heart H and a second face 113 of the housing 110 facing away from the heart H. The first face 111 of the housing 110 includes an inlet cannula 112 extending into the left ventricle LV of the heart H. The second face 113 of the housing 110 has a chamfered edge 114 to avoid irritating other tissue that may come into contact with the blood pump 100, such as the patient's diaphragm. To construct the illustrated shape of the puck-shaped housing 110 in a compact form, a stator 120 and electronics 130 of the pump 100 are positioned on the inflow side of the housing toward first face 111, and a rotor 140 of the pump 100 is positioned along the second face 113. This positioning of the stator 120, electronics 130, and rotor 140 permits the edge 114 to be chamfered along the contour of the rotor 140, as illustrated in at least FIGS. 2-4, for example.

[0030] Referring to FIG. 4, the blood pump 100 includes a dividing wall 115 within the housing 110 defining a blood flow conduit 103. The blood flow conduit 103 extends from an inlet opening 101 of the inlet cannula 112 through the stator 120 to an outlet opening 105 defined by the housing 110. The rotor 140 is positioned within the blood flow conduit 103. The stator 120 is disposed circumferentially about a first portion 140a of the rotor 140, for example about a permanent magnet 141. The stator 120 is also positioned relative to the rotor 140 such that, in use, blood flows within the blood flow conduit 103 through the stator 120 before reaching the rotor 140. The permanent magnet 141 has a permanent magnetic north pole N and a permanent magnetic south pole S for combined active and passive magnetic levitation of the rotor 140 and for rotation of the rotor 140. The rotor 140 also has a second portion 140b that includes impeller blades 143. The impeller blades 143 are located within a volute 107 of the blood flow conduit such that the impeller blades 143 are located proximate to the second face 113 of the housing 110.

[0031] 100311 The puck shaped housing 110 further includes a peripheral wall 116 that extends between the first face 111 and a removable cap 118. As illustrated, the peripheral wall 116 is formed as a hollow circular cylinder having a width W between opposing portions of the peripheral wall 116. The housing 110 also has a thickness T between the first face 111 and the second face 113 that is less than the width W. The thickness T is from about 0.5 inches to about 1.5 inches, and the width W is from about 1 inch to

about 4 inches. For example, the width W can be approximately 2 inches, and the thickness T can be approximately 1 inch.

[0032] The peripheral wall 116 encloses an internal compartment 117 that surrounds the dividing wall 115 and the blood flow conduit 103, with the stator 120 and the electronics 130 disposed in the internal compartment 117 about the dividing wall 115. The removable cap 118 includes the second face 113, the chamfered edge 114, and defines the outlet opening 105. The cap 118 can be threadedly engaged with the peripheral wall 116 to seal the cap 118 in engagement with the peripheral wall 116. The cap 118 includes an inner surface 118a of the cap 118 that defines the volute 107 that is in fluid communication with the outlet opening 105.

[0033] Within the internal compartment 117, the electronics 130 are positioned adjacent to the first face 111 and the stator 120 is positioned adjacent to the electronics 130 on an opposite side of the electronics 130 from the first face 111. The electronics 130 include circuit boards 131 and various components carried on the circuit boards 131 to control the operation of the pump 100 (e.g., magnetic levitation and/or drive of the rotor) by controlling the electrical supply to the stator 120. The housing 110 is configured to receive the circuit boards 131 within the internal compartment 117 generally parallel to the first face 111 for efficient use of the space within the internal compartment 117. The circuit boards also extend radially-inward towards the dividing wall 115 and radially-outward towards the peripheral wall 116. For example, the internal compartment 117 is generally sized no larger than necessary to accommodate the circuit boards 131, and space for heat dissipation, material expansion, potting materials, and/or other elements used in installing the circuit boards 131. Thus, the external shape of the housing 110 proximate the first face 111 generally fits the shape of the circuit boards 131 closely to provide external dimensions that are not much greater than the dimensions of the circuit boards 131.

[0034] With continued reference to FIGS. 4 and 5, the stator 120 includes a back iron 121 and pole pieces 123a-123f arranged at intervals around the dividing wall 115. The back iron 121 extends around the dividing wall 115 and is formed as a generally flat disc of a ferromagnetic material, such as steel, in order to conduct magnetic flux. The back iron 121 is arranged beside the control electronics 130 and provides a base for the pole pieces 123a-123f.

[0035] Each of the pole piece 123a-123f is L-shaped and has a drive coil 125 for generating an electromagnetic field to rotate the rotor 140. For example, the pole piece has a first leg 124a that contacts the back iron 121 and extends from the back iron 121 towards the second face 113. The pole piece 123a may also have a second leg 124b that extends from the first leg 124a through an opening of a circuit board 131 towards the dividing wall 115 proximate location of the permanent magnet 141 of the rotor 140. In an aspect, each of the second legs 124b of the pole pieces 123a-123f is sticking through an opening of the circuit board 131. In an aspect, each of the first legs 124a of the pole pieces 123a-123f is sticking through an opening of the circuit board 131. In an aspect, the openings of the circuit board are enclosing the first legs 124a of the pole pieces 123a-123f.

[0036] In a general aspect, the implantable blood pump 100 may include a Hall sensor that may provide an output voltage, which is directly proportional to a strength of a magnetic field that is located in between at least one of the

pole pieces **123a-123f** and the permanent magnet **141**, and the output voltage may provide feedback to the control electronics **130** of the pump **100** to determine if the rotor **140** and/or the permanent magnet **141** is not at its intended position for the operation of the pump **100**. For example, a position of the rotor **140** and/or the permanent magnet **141** may be adjusted, e.g. the rotor **140** or the permanent magnet **141** may be pushed or pulled towards a center of the blood flow conduit **103** or towards a center of the stator **120**.

[0037] Each of the pole pieces **123a-123f** also has a levitation coil **127** for generating an electromagnetic field to control the radial position of the rotor **140**. Each of the drive coils **125** and the levitation coils **127** includes multiple windings of a conductor and the pole pieces **123a-123f**. Particularly, each of the drive coils **125** is wound around two adjacent ones of the pole pieces **123**, such as pole pieces **123d** and **123e**, and each levitation coil **127** is wound around a single pole piece. The drive coils and the levitation coils **127** are wound around the first legs of the pole pieces **123**, and magnetic flux generated by passing electrical current through the coils **125** and **127** during use is conducted through the first legs and the second **127** legs of the pole pieces **123** and the back iron **121**. The drive coils **125** and the levitation coils **127** of the stator **120** are arranged in opposing pairs and are controlled to drive the rotor and to radially levitate the rotor **140** by generating electromagnetic fields that interact with the permanent magnetic poles S and N of the permanent magnet **141**. Because the stator **120** includes both the drive coils **125** and the levitation coils **127**, only a single stator is needed to levitate the rotor **140** using only passive and active magnetic forces. The permanent magnet **141** in this configuration has only one magnetic moment and is formed from a monolithic permanent magnetic body **141**. For example, the stator **120** can be controlled as discussed in U.S. Pat. No. 6,351,048, the entire contents of which are incorporated herein by reference for all purposes. The control electronics **130** and the stator **120** receive electrical power from a remote power supply via a cable **119** (FIG. 3). Further related patents, namely U.S. Pat. Nos. 5,708,346, 6,053,705, 6,100,618, 6,222,290, 6,249,067, 6,378,251, 6,351,048, 6,355,998, 6,634,224, 6,879,074, and 7,112,903, all of which are incorporated herein by reference for all purposes in their entirety.

[0038] The rotor **140** is arranged within the housing **110** such that its permanent magnet **141** is located upstream of impeller blades in a location closer to the inlet opening **101**. The permanent magnet **141** is received within the blood flow conduit **103** proximate the second legs **124b** of the pole pieces **123** to provide the passive axial centering force through interaction of the permanent magnet **141** and ferromagnetic material of the pole pieces **123**. The permanent magnet **141** of the rotor **140** and the dividing wall **115** form a gap **108** between the permanent magnet **141** and the dividing wall **115** when the rotor **140** is centered within the dividing wall **115**. The gap **108** may be from about 0.2 millimeters to about 2 millimeters. For example, the gap **108** is approximately 1 millimeter. The north permanent magnetic pole N and the south permanent magnetic pole S of the permanent magnet **141** provide a permanent magnetic attractive force between the rotor **140** and the stator **120** that acts as a passive axial centering force that tends to maintain the rotor **140** generally centered within the stator **120** and tends to resist the rotor **140** from moving towards, the first face **111** or towards the second face **113**. When the gap **108** is smaller,

the magnetic attractive force between the permanent magnet **141** and the stator **120** is greater, and the gap **108** is sized to allow the permanent magnet **141** to provide the passive magnetic axial centering force having a magnitude that is adequate to limit the rotor **140** from contacting the dividing wall **115** or the inner surface **118a** of the cap **118**. The rotor **140** also includes a shroud **145** that covers the ends of the impeller blades **143** facing the second face **113** that assists in directing blood flow into the volute **107**. The shroud **145** and the inner surface **118a** of the cap **118** form a gap **109** between the shroud **145** and the inner surface **118a** when the rotor **140** is levitated by the stator **120**. The gap **109** is from about 0.2 millimeters to about 2 millimeters. For example, the gap **109** is approximately 1 millimeter.

[0039] As blood flows through the blood flow conduit **103**, blood flows through a central aperture **141a** formed through the permanent magnet **141**. Blood also flows through the gap **108** between the rotor **140** and the dividing wall **115** and through the gap **109** between the shroud **145** and the inner surface **108a** of the cap **118**. The gaps **108** and **109** are large enough to allow adequate blood flow to limit clot formation that may occur if the blood is allowed to become stagnant. The gaps **108** and **109** are also large enough to limit pressure forces on the blood cells such that the blood is not damaged when flowing through the pump **100**. As a result of the size of the gaps **108** and **109** limiting pressure forces on the blood cells, the gaps **108** and **109** are too large to provide a meaningful hydrodynamic suspension effect. That is to say, the blood does not act as a bearing within the gaps **108** and **109**, and the rotor is only magnetically-levitated. In various embodiments, the gaps **108** and **109** are sized and dimensioned so the blood flowing through the gaps forms a film that provides a hydrodynamic suspension effect. In this manner, the rotor can be suspended by magnetic forces, hydrodynamic forces, or both.

[0040] Because the rotor **140** is radially suspended by active control of the levitation coils **127** as discussed above, and because the rotor **140** is axially suspended by passive interaction of the permanent magnet **141** and the stator **120**, no rotor levitation components are needed proximate the second face **113**. The incorporation of all the components for rotor levitation in the stator **120** (i.e., the levitation coils **127** and the pole pieces **123**) allows the cap **118** to be contoured to the shape of the impeller blades **143** and the volute **107**. Additionally, incorporation of all the rotor levitation components in the stator **120** eliminates the need for electrical connectors extending from the compartment **117** to the cap **118**, which allows the cap to be easily installed and/or removed and eliminates potential sources of pump failure.

[0041] In use, the drive coils **125** of the stator **120** generate electromagnetic fields through the pole pieces **123** that selectively attract and repel the magnetic north pole N and the magnetic south pole S of the rotor **140** to cause the rotor **140** to rotate within stator **120**. For example, the Hall sensor may sense a current position of the rotor **140** and/or the permanent magnet **141**, wherein the output voltage of the Hall sensor may be used to selectively attract and repel the magnetic north pole N and the magnetic south pole S of the rotor **140** to cause the rotor **140** to rotate within stator **120**. As the rotor **140** rotates, the impeller blades **143** force blood into the volute **107** such that blood is forced out of the outlet opening **105**. Additionally, the rotor draws blood into pump **100** through the inlet opening **101**. As blood is drawn into the blood pump by rotation of the impeller blades **143** of the

rotor **140**, the blood flows through the inlet opening **101** and flows through the control electronics **130** and the stator **120** toward the rotor **140**. Blood flows through the aperture **141a** of the permanent magnet **141** and between the impeller blades **143**, the shroud **145**, and the permanent magnet **141**, and into the volute **107**. Blood also flows around the rotor **140**, through the gap **108** and through the gap **109** between the shroud **145** and the inner surface **118a** of the cap **118**. The blood exits the volute **107** through the outlet opening **105**, which may be coupled to an outflow cannula.

[0042] FIG. 6 is a schematic diagram of an overall communication architecture of the mechanical support system of FIG. 1. A driveline couples the implanted blood pump **100** to the system controller **20**, which monitors system operation via various software applications. The blood pump **100** itself also includes several software applications that are executable by the on board electronics **130** (e.g., processors) for various functions, such as to control radial levitation and/or drive of the rotor of the pump **100** during operation. The system controller **20** may in turn be coupled to batteries **22** or a power module **30** that connect to an AC electrical outlet. The system controller **20** may also include an emergency backup battery (EBB) to power the system (e.g., when the batteries **22** are depleted) and a membrane overlay, including bluetooth capabilities for wireless data communication. An external computer having a system monitor **32** that is configurable by an operator, such as clinician or patient, may further be coupled to the circulatory support system for configuring the system controller **20**, implanted blood pump **100**, and/or patient parameters, updating software on the system controller **20** and/or implanted blood pump **100**, monitoring system operation, and/or as a conduit for system inputs or outputs.

[0043] In some embodiments, the software applications of the blood pump **100** can include, for example, an initial program loader (IPL), loader software, and/or application software. In some embodiments, the IPL can be configured to select and load one or several software applications corresponding, to one or several modes of operation of the blood pump **100**. In some embodiments, these, one or several modes of operation of the blood pump **100** can include an operation mode, a test mode, a fault mode, or the like. The selecting and loading of one or several software applications corresponding to one or several modes of operation of the blood pump **100** can include, for example, selecting and loading one or several of the loader software and/or the application software. In some embodiments, the can include information relating to one or several failsafe and/or fault protocols that can be used by the blood pump **100**. Some of these failsafe and/or fault protocols will be discussed at length below.

[0044] The loader software, can, in some embodiments, be configured to direct the operation of the blood pump **100** during the loading of one or several software applications onto the blood pump **100**. These one or several software applications can include, for example, one or several application softwares, one or several IPL applications, or the like. In some embodiments, the loader software can prescribe one or several processes for updating and/or loading one or several software applications onto the blood pump **100**. These processes and associated failsafes will be discussed in greater details below.

[0045] The application software can include one or several parameters for directing the pumping operation of the blood

pump **100**. In some embodiments, the application software can comprise one of a clinical application software which can be configured to control the operation of the blood pump **100** when implanted in a patient, and in some embodiments, the application software can comprise a production software that can be configured to control the operation of the blood pump **100** during production and/or testing of the blood pump **100**.

[0046] In some embodiments, these parameters can specify a control or control regimen for the position and/or motion of the rotor **140**. For example, these parameters can specify the aspects of the levitation control and/or rotation control of the rotor **140**.

[0047] In some embodiments, the parameters of the application software can specify, for example a desired performance of the blood pump **100** and/or one or several desired performance parameters, such as, for example, a desired pump speed, and desired pumped flow rate, a pulse generation, or the like. In some embodiments, these parameters can be actively used to control the operation of the blood pump **100**, and in some embodiments these parameters can be stored during normal operation of the blood pump **100** and used as part of one or several failsafe and/or fault protocols. In some embodiments, the parameters of the application software can specify the generation and/or collection of data from the blood pump **100** and/or interfacing of the blood pump **100** to other components of the mechanical circulatory support system **10**.

[0048] In some embodiments, the application software can comprises a first application software containing parameters relating to the current operation of the blood pump, and in some embodiments, the application software can comprise a second application software containing parameters unrelated to the current operation of the blood pump **100**. In one embodiment, for example, the blood pump **100** can comprise the second application software as a backup to the first application software. In some embodiments, the first application software can be identical to the second application software, and in some embodiments, the first application can be different than the second application software.

[0049] FIG. 7 is at schematic diagram illustrating one embodiment of the blood pump **100**. As seen in FIG. 7, the blood pump **100** includes electronics **130** and a rotary motor **200**, which rotary motor **200** call include the stator **120** and the rotor **140**. As seen in FIG. 7, the electronics **130** can include a control unit **202** that can control the operations of the blood pump **100** and can interact with other components of the mechanical circulatory support system **10**. As shown, the control unit **202** can communicate with the rotary motor **200** and with the communications module **208**. In some embodiments, the control unit **202** and electronics **130** can be located in the same implantable housing **110** as the rotary motor **200**, and in some embodiments, the control unit and electronics can be located in a separate implantable housing than the blood pump housing **110**. For example, the system controller **20** can be located in an implantable housing, and the control unit **202** and electronics **130** can be co-located in that same implantable housing in a fully implantable transcutaneous energy transfer system.

[0050] The control unit **202** can, include a processor **204**. The processor **204** can provide instructions to, and receive information from the other components of the blood pump **100** and/or from the other components of the mechanical circulatory support system **10**. The processor **204** can act

according to stored instructions, which stored instructions can be located in memory 206 associated with the processor 204 and/or in other components of the blood pump 100 and/or of the mechanical circulatory support system 10. The processor 204 can comprise a microprocessor, such as a microprocessor from Intel® or Advanced Micro Devices, Inc.®, or the like.

[0051] In some embodiments, the stored instructions directing the operation of the processor 204 may be implemented by hardware, software, scripting languages, firmware, middleware, microcode, hardware description languages, and/or any combination thereof. When implemented in software, firmware, middleware, scripting, language, and/or microcode, the program code or code segments to perform the necessary tasks may be stored in a machine readable medium such as a storage medium. A code segment or machine-executable instruction may represent a procedure, a function, a subprogram, a program, a routine, a subroutine, a module, a software package, a script, a class, or any combination of instructions, data structures, and/or program statements. A code segment may be coupled to another code segment or a hardware circuit by passing and/or receiving information, data, arguments, parameters, and/or memory contents. Information, arguments, parameters, data, etc. may be passed, forwarded, or transmitted via any suitable means including memory sharing, message passing, token passing, network transmission, etc.

[0052] As seen in FIG. 7, the control unit 202 includes a memory 206. In this embodiment, the memory 206 is the storage medium containing the stored instructions. The memory 206 may represent one or more memories for storing data, including read only memory (ROM), random access memory (RAM), magnetic RAM, core memory, magnetic disk storage mediums, optical storage mediums, flash memory devices and/or other machine readable mediums for storing information. In some embodiments, the memory 206 may be implemented within the processor 204 or external to the processor 204. In some embodiments, the memory 206 can be any type of long term, short term, volatile, nonvolatile, or other storage medium and is not to be limited to any particular type of memory or number of memories, or type of media upon which memory is stored. In some embodiments, the memory 206 can include, for example, one or both of volatile and nonvolatile memory. In one specific embodiment, the memory 206 can include a volatile portion such as RAM memory, and a nonvolatile portion such as flash memory.

[0053] In some embodiments, the memory 206 can be divided into one or several partitions. In one embodiment in which the memory 206 contains a plurality of software applications, the memory 206 can be divided into a plurality of partitions so as to be, for example, in a one to one relationship with the number of software applications in the plurality of software applications. In some embodiments, some or all of the software applications stored in the memory 206 can be stored in a unique one of the partitions in the memory 206. In one embodiment in which the memory 206 comprises a volatile portion and a nonvolatile portion, the partitions can be created in one or both of the volatile portion and the nonvolatile portion. Specifically, in one embodiment in which the memory 206 comprises RAM and flash memory, the flash memory can be divided into a plurality of partitions. In some embodiments, the plurality of

software applications can be stored in the plurality of partitions in the flash memory.

[0054] As described above, the processor 204 can send information and/or signals with and/or receive information and/or signals from the communications module 208. The communications module 208 can include features configured to send and receive information, including, for example, an antenna, a transmitter, receiver, or any other feature that can send and receive information. The communications module 208 can communicate via a wired or wireless link with, for example, the system controller 20 and/or the rotary motor 200. In some embodiments, the communications module 208 can communicate via cellular networks, WLAN networks, or any other wireless network. In some embodiments, the blood pump 100 can be configured to generate a signal in response to some or all communications received from in the system controller 20, and/or to not generate a signal to the system controller 20 unless a signal from the system controller 20 has been first received by the blood pump 100.

[0055] FIG. 8 is a flow-chart illustrating one embodiment of a process 220 for operation of the blood pump 100. The process 220 can be performed to start the pumping of the blood pump 100, and can be performed using components of the blood pump 100 including, for example, the control unit 202. The process 220 begins, in some embodiments, at block 222 wherein the blood pump 100 is powered up. In some embodiments, the powering up the blood pumped 100 can include the receipt of power by the blood pump 100 from one of the batteries 22 and/or other power source. In some embodiments, after the blood pump 100 is powered, the process 220 proceeds to block 224 wherein the IPL is run. In some embodiments, the running of the IPL can include, for example, retrieval of the IPL from the memory 206 and the execution of IPL instructions by the processor 204.

[0056] After the IPL is running, the process 220 proceeds to block 226 wherein the IPL selects one or several software applications for control of the blood pump 100. In some embodiments, the one or several software applications can be selected from the memory 206. After the one or several software applications have been selected, the process 220 proceeds to block 228 wherein the IPL determines the validity of the one or several selected software applications. In some embodiments, this can include the determination of the functionality of the one or several software applications and/or the detection of any faults and/or errors in, or caused one or several selected software applications.

[0057] After the IPL has determined the validity of the one or several selected software applications, the process 220 proceeds to block 210 wherein the IPL retrieves the one or sever selected software applications from the memory 206 and starts the one or al selected software applications. As specifically seen in FIG. 8, the IPL can, for example, and as depicted in block 232, copy a software application stored in one of the partitions of the memory 206, such as, for example, a second partition in the flash memory, to the RAM and start the copied software application. Similarly, in one embodiment the IPL can, and as depicted in block 234, copy a software application stored in one of the partitions of the memory, such as, for example, a third partition in the flash memory, to the RAM and start the copied software application. In some embodiments, the starting of the software application stored in one of the second partition and the third partition can result in the starting of the blood pump 100, the

starting of the movement of the rotor **140**, and the starting of the associated pumping of blood. In one embodiment, the IPL can, as depicted in block **236**, start the loader software. In some embodiments, the loader software can be started as an early step in the update of the blood pump **100**.

[0058] FIG. **9** is a schematic illustration of one embodiment of memory **206** of the blood pump **100**. As depicted in FIG. **9**, the memory **206** of the blood pump can include volatile memory, such as RAM **260** and non-volatile memory such as flash **262**. The flash **262** can be divided into several partitions. In the embodiment depicted in FIG. **9**, the flash **262** is divided into partition **0 264-A**, partition **1 264-B**, partition **2 264-C**, partition **3 264-D**, partition **4 264-E**, partition **5 264-F**. As seen in FIG. **9**, some of the partitions **264-A-264-F** contain a software application. Specifically, partition **0 264-A** contains the IPL and loader software, partition **1 264-B** contains a backup copy of the IPL and loader software, and partition **2 264-C** and partition **3 264-D** each contain application software and application software information. In some embodiments, partition **2 264-C** and partition **3 264-D** correspond to the second and third memory partitions, respectively.

[0059] In some embodiments, and as seen in FIG. **9**, partition **2 264-C** and partition **3 264-D** are each divided into first and second portions. In the embodiment depicted in FIG. **9**, the first portion of partition **2 264-C** contains first application software **266** and the first portion of partition **3 264-D** contains second application software **268**. In the embodiment depicted in FIG. **9**, the second portion of partition **2 264-C** contains first application software information **270** and the second portion of partition **3 264-D** contains second application software information **272**. In some embodiments, the application software in can include, a datum that can be used to identify/verify the application software, such as, for example, a hash or a checksum and information either absolutely or relatively identifying the time and/or date that the application software was loaded on the blood pump **100**.

[0060] FIG. **10** is a flowchart illustrating one embodiment of a process **300** for operation of the blood pump **100** when communication with the system controller **20** is lost or interrupted. In some embodiments, the process **300** can be performed on the blood pump **100** and/or by components communicatively coupled to the blood pump **100** such as, for example, the electronics **130** and/or the control unit **202**. The process **300** begins at block **302** wherein the blood pump **100** is started, and specifically, wherein the pumping of the blood pump **100** is initiated. In some embodiments, the blood pump **100** can be started according to the process **220** shown in FIG. **8**.

[0061] After the blood pump **100** has been started, the process **300** proceeds to block **304**, wherein a control signal is received from the system controller **20**. In some embodiments, the control signal received from the system controller **20** can be used by the control unit **202** in the controlling of the position, motion, and/or performance of the rotor **140** of the blood pump **100**. The control signal can be received by the control unit **202** of the blood pump **100**, and specifically, in some embodiments, can be received by the communications module **206** of the blood pump **100**.

[0062] After the control signal has been received, the process **300** proceeds to block **306**, wherein the blood pump operation/performance is matched to the operation/performance specified by the control signal. In some embodi-

ments, this can include determining the current operation/performance of the blood pump **100**, comparing the current operation/performance of the blood pump **100** to the operation/performance specified by the control signal, and controlling components of the stator **120** to achieve the operation/performance specified by the control signal if the current operation/performance of the blood pump **100** differs from the operation/performance specified by the control signal. In some embodiments, the matching of the pump operation/performance to the operation/performance specified in the control signal can further include the generation and transmission of a message by the control unit **202** to the system controller **20**, which message can identify the current operation/performance of the blood pump **100**.

[0063] After the blood pump operation/Performance has been matched to the operation/performance specified by the control signal, the process **300** proceeds to block **308**, wherein at least one back-up parameter is stored. In some embodiments, the back-up parameters can include one or several back-up parameters, and can be stored in the memory **206** of the blood pump **100**. Specifically, in some embodiments, the back-up parameters can be stored in one of the partitions **264-A-264-F** of the flash memory. In some embodiments, the one or several back up parameters can be received as a component of the control signal, in some embodiments, the one or several back-up parameters can be created from data received from the control signal, and in some embodiments, the one or several back-up parameters can be received separate from the receipt of the control signal. The details of the creation of the one or several back-up parameters will be discussed at greater length below.

[0064] After the one or several back-up parameters have been stored, the process **300** proceeds to decision state **310**, wherein it is determined if additional control signals and/or communications from the system controller **20** have been received. In some embodiments, this can include receiving information from, for example, the communications module **208** relating to any received communications. If an additional communication and/or control signal has been received, then the process **300** returns to block **306** and proceeds as outlined above.

[0065] If no additional control signal and/or communication has been received, then the process **300** proceeds to decision state **312**, wherein it is determined if the communication time has been exceeded. In some embodiments, the communication time can be, for example, an anticipated and/or desired frequency with which communications are expected from the system controller **20**. In one embodiment, for example, the communication time can indicate that a communication is expected from the system controller **20** every ten seconds, every five seconds, every second, twice a second, five times a second, ten times a second, and/or at any other or intermediate frequency.

[0066] In some embodiments, the communication time can be the maximum length of time that can pass without receiving a communication from the system controller **20** before an error is identified and/or an alarm is triggered, in one embodiment, for example, this amount of time can be one minute, thirty seconds, ten seconds, five seconds, one second, 0.5 seconds, or any other or intermediate length of time.

[0067] In some embodiments, the properties, of the communication time can be identified in communication time

information stored in, for example, the memory 206 of the blood pump 100. In some embodiments, the communication time information is retrieved from the memory, the length of time that has passed since the last received communication is determined, and the determined length of time that has passed since the last received communication is compared to the communication time, if the length of time that has passed since the last received communication is less than the communication time, then the process 300 proceeds to block 314 and waits until the end of the communication time. In some embodiments, the process 300 then proceeds to decision state 310 and proceeds as outlined above.

[0068] If it is determined that the communication time has been exceeded, then the process 300 proceeds to block 316, wherein the loss or interruption of communication is indicated. In some embodiments, the loss of communication can be indicated by triggering an error and/or an alarm. In some embodiments, the loss of communication can be indicated by a value associated with the triggered error and/or alarm, and/or associated with the loss of communication. This value can be stored in the memory 206, and in some embodiments, this value can be stored in the RAM.

[0069] After the loss of communication has been indicated, the process 300 proceeds to block 318, wherein one or several back-up parameters are retrieved. In some embodiments, the one or several back-up parameters can contain some or all of the parameters contained in the control signals received from the system controller 20 and that relate to the performance of the blood pump 100 including, for example, the speed, operational mode, or pulse parameter of the rotary motor 200. In some embodiments, the one or several back-up parameters can be retrieved from the memory 206 such as, for example, the flash memory.

[0070] After the one or several back-up parameters have been retrieved, the process 300 proceeds to block 320, wherein the wherein the blood pump operation/performance is matched to the operation/performance specified by the one or several back-up parameters. In some embodiments, this can include determining the current operation/performance of the blood pump 100, comparing the current operation/performance of the blood pump 100 to the operation/performance specified by the one or several back-up parameters, and controlling components of the stator 120 to achieve the operation/performance specified by the one or several back-up parameters, if the current operation/performance of the blood pump 100 differs from the operation/performance specified by the one or several back-up parameters. In some embodiments, controlling components of the stator 120 to achieve the operation/performance specified by the one or several back-up parameters can include generating one or several control signals that direct components of the stator to achieve the pump performance specified by the at least one back-up parameter.

[0071] After the blood pump operation per has been matched to the operation/performance specified by the one or several back-up parameters, the process 300 proceeds to block 322, wherein a new control signal is received. In some embodiments, the new control signal can be received from the system controller 20, and can be received when communication between the system controller 20 and the blood pump 100 is reestablished. In some embodiments, the new control signal can be received at any time. In some embodiments, the time between the control signal received in block

304 and the new control signal can be any time larger than the communication time. In some embodiments, this time between the control signal received in block 304 and the new control signal can be, for example, 1 second, 5 seconds, 10 seconds, 20 seconds, 30 seconds, 1 minute, 5 minutes, 10 minutes, 30 minutes, 1 hour, 1 day, 1 week, 1 month, 1 year, and/or any other or intermediate length of time. In some embodiments, the receipt of the new control signal can lead to the triggering of a return to normal status from the error and/or alarm state indicated in block 316. In some embodiments, a value can be associated with the restored normal state of operation, which value can be stored in the memory 206, and in some embodiments, in the RAM.

[0072] After the new control signal has been received, the process 300 proceeds to block 324, wherein the status response is provided. In some embodiments, the status response can be a response indicative of the status of the blood pump 100 that can be provided by the blood pump 100 to the system controller 20. In some embodiments, the status response can include information indicative of the current operation of the blood pump 100 including, for example, a speed, a mode, or a pulse parameter.

[0073] After the status response has been received, the process 300 proceeds to block 326, wherein the blood pump operation/performance is matched to the operation/performance specified by the new control signal. In some embodiments, this can include determining the current operation/performance of the blood pump 100, comparing the current operation/performance of the blood pump 100 to the operation/performance specified by the new control signal, and controlling components of the stator 120 to achieve the operation/performance specified by the new control signal if the current operation/performance of the blood pump 100 differs from the operation/performance specified by the new control signal. In some embodiments, the matching of the blood pump operation/performance to the operation/performance specified in the new control signal can further include the generation and transmission of a message by the control unit 202 to the system controller 20, which message can identify the current operation performance of the blood pump 100.

[0074] FIG. 11 is a flowchart illustrating one embodiment of process 400 for generating a back-up parameter. In some embodiments, the process 400 can be performed as part of block 308 shown in FIG. 10. The process 400 can be performed by the blood pump 100 and/or components thereof. The process begins at block 402, wherein control signal portions are identified. In some embodiments, the control signal can comprise one or several portions which can, in some embodiments, include unique information. In one embodiment, for example, the control signal can include a first portion that can include information relating to a speed of the blood pump 100, and a second portion that can include information relating to a mode of operation of the blood pump 100 and/or a pulse parameter of the blood pump 100. In one embodiment, the mode of operation of the blood pump 100 can specify pulsatile and/or non-pulsatile operation of the blood pump 100. In one embodiment, the pulse parameter can specify one of a pulse duration, a systolic pressure, a diastolic pressure, and/or a pulse pressure.

[0075] After the portions of the control signal have been identified, the process 400 proceeds to block 404 wherein the back-up parameter is extracted from, for example, the control signal. In some embodiments, the extraction of the

back-up parameter can include the separation of one of the portions of the control signal from the other of the portions of the control signal. In one embodiment, the back-up parameter can comprise the first portion of the control signal, which first portion includes information relating to the speed of the blood pump **100**.

[**0076**] After the back-up parameter has been extracted from the control signal, the process **400** proceeds to block **406**, wherein the back-up parameter is stored. In some embodiments, the back-up parameter can be stored in the memory **206**, including, for example, in the flash memory or in one of the partitions of the flash memory. After the back-up parameter has been stored, the process **400** proceeds to block **408** and continues with block **310** of FIG **10**.

[**0077**] In the foregoing specification, the invention is described with reference to specific embodiments thereof, but those skilled in the art will recognize that the invention is not limited thereto. Various features and aspects of the above-described invention can be used individually or jointly. Further, the invention can be utilized in any number of environments and applications beyond those described herein without departing from the broader spirit and scope of the specification. The specification and drawings are, accordingly, to be regarded as illustrative rather than restrictive. It will be recognized that the terms “comprising,” “including,” and “having,” as used herein, are specifically intended to be read as open-ended terms of art.

What is claimed is:

1. A mechanical circulatory support system comprising:
 - as controller configured to generate control signals comprising at least one performance parameter and to repeatedly transmit the control signals within consecutive time periods; and
 - an implantable blood pump communicatively coupled to the controller, the blood pump comprising:
 - a rotary motor; and
 - a control unit communicatively coupled with the rotary motor and configured to:
 - receive the control signals from the controller;
 - track the consecutive time periods; and
 - retrieve at least one back-up parameter if a control signal is not received from the controller within a predetermined time or number of the consecutive time periods to ensure operation of the implantable blood pump during a communication interruption or loss.
2. The mechanical circulatory support system of claim **1**, wherein the control unit is further configured to control at least one of the motion and position of the rotary motor.
3. The mechanical circulatory support system of claim **1**, wherein the control unit is further configured to control the speed, mode, or pulse parameter of the motor according to the received control signals or the at least one back-up parameter.
4. The mechanical circulatory support system of claim **3**, wherein the control unit is further configured to:
 - determine a current pump performance;
 - compare the current pump performance to the at least one back-up parameter; and
 - generate control signals to achieve the pump performance specified by the at least one back-up parameter.
5. The mechanical circulatory support system of claim **1**, wherein the predetermined time comprises at least 5 seconds.
6. The mechanical circulatory support system of claim **1**, wherein the consecutive time periods have a length of time of less than 1 second.
7. The mechanical circulatory support system of claim **6**, wherein the predetermined number comprises at least five consecutive time periods.
8. The mechanical circulatory support system of claim **1**, wherein the at least one performance parameter comprises at least one of a pump speed, a pump operational mode, and a pulse parameter.
9. The mechanical circulatory support system of claim **8**, wherein the pulse parameter comprises one of a pulse duration, a systolic pressure, a diastolic pressure, and a pulse pressure.
10. The mechanical circulatory support system of claim **8**, wherein the pump operational mode comprises at least one of continuous speed, pulsatile pumping, or non-pulsatile, mode.
11. The mechanical circulatory support system of claim **1**, wherein the at least one back-up parameter comprises at least one of a pump speed, pump operational mode, and a pulse parameter.
12. The mechanical circulatory system of claim **11**, wherein the control unit is configured to generate the at least one back-up parameter from the control signal received from the controller.
13. The mechanical circulatory system of claim **12**, wherein the control unit comprises memory which stores the at least one back up parameter.
14. The mechanical circulatory support system of claim **1**, wherein the control unit is configured to return to operation based on control signals received from the external controller when communication is re-established.
15. The mechanical circulatory support system of claim **1**, wherein the controller comprises an external or implantable controller configured to wirelessly transmit the control signals.
16. The mechanical circulatory support system of claim **1**, wherein the controller comprises an external or implantable controller having a driveline coupled to the implantable pump to transmit the control signals.
17. The mechanical circulatory support system of claim **1**, wherein the control unit is configured to control the mode of the rotary motor according to the received control signals or the at least one back-up parameter.
18. The mechanical circulatory support system of claim **1**, wherein the control unit is configured to control the pulse parameter of the rotary motor according to the received control signals or the at least one back-up parameter.
19. An implantable blood pump comprising:
 - a rotary motor;
 - a control unit communicatively coupled with the rotary motor and configured to:
 - repeatedly receive control signals comprising at least one performance parameter;
 - track receipt of the control signals over a time period; and
 - retrieve at least one back-up parameter if a control signal is not received within a predetermined time period to ensure operation of the implantable blood pump during a communication interruption or loss.
20. The implantable blood pump of claim **19**, wherein the control unit is configured to provide a status update in response to a received control signal.

21. The implantable blood pump of claim 19, wherein the at least one back-up parameter is retrieved if a control signal is not received within the predetermined time period of 5 seconds.

22. The implantable blood pump of claim 19, wherein the at least one performance parameter comprises at least one of a pump speed, a pump operational mode, and a pulse parameter.

23. The implantable blood pump of claim 22, wherein the pulse parameter comprises one of a pulse duration, a systolic pressure, a diastolic pressure, and a pulse pressure.

24. The implantable blood pump of claim 22, wherein the pump operational mode comprises at least one of continuous speed, pulsatile pumping, non-pulsatile mode.

25. The implantable blood pump of claim 22, wherein the at least one back-up parameter comprises at least one of a pump speed, a pump operational mode, and a pulse parameter.

26. The implantable blood pump of claim 22, wherein the control unit is configured to return to operation based on control signals received from the controller when a new control signal is received.

27. The implantable blood pump of claim 22, wherein the rotary motor is located within a first implantable housing and the control unit is located in a second implantable housing.

* * * * *