



US006631607B1

(12) **United States Patent**
Kaesgen

(10) **Patent No.:** **US 6,631,607 B1**
(45) **Date of Patent:** **Oct. 14, 2003**

(54) **ZERO TURN TRACTOR WITH FRONT MOUNTED ENGINE**

(75) Inventor: **Hartmut Kaesgen, Berea, OH (US)**

(73) Assignee: **MTD Products Inc, Valley City, OH (US)**

(*) Notice: Subject to any disclaimer, the term of this patent is extended or adjusted under 35 U.S.C. 154(b) by 0 days.

(21) Appl. No.: **09/580,245**

(22) Filed: **May 26, 2000**

Related U.S. Application Data

(60) Provisional application No. 60/154,061, filed on Sep. 16, 1999.

(51) **Int. Cl.⁷** **A01D 34/03; A01D 34/43; A01D 34/64**

(52) **U.S. Cl.** **56/14.7; 56/22; 180/374**

(58) **Field of Search** **56/14.7, 16.7, 56/DIG. 22, 14.8; 180/374, 337, 371, 344, 6.2; 280/24, 78, 93.513, 93.514**

(56) **References Cited**

U.S. PATENT DOCUMENTS

4,399,882 A	8/1983	O'Neill et al.	180/6.48
4,616,724 A	10/1986	Lemke	180/6.48
4,977,733 A	* 12/1990	Samejima et al.	56/14.7
5,113,819 A	* 5/1992	Murakawa et al.	123/198 E
RE34,057 E	9/1992	Middleworth	180/6.2
5,168,970 A	12/1992	Hough et al.	192/4 R
5,207,187 A	* 5/1993	Kurohara et al.	123/41.7
5,214,906 A	* 6/1993	Saki et al.	56/320.2
5,383,528 A	1/1995	Nicol	180/6.2

5,447,321 A	* 9/1995	Hurlburt et al.	280/97
5,502,957 A	4/1996	Roberston	56/11.9
5,600,944 A	2/1997	Wright et al.	56/14.7
5,644,903 A	7/1997	Davis, Jr.	56/10.8
5,649,606 A	7/1997	Bebernes et al.	180/307
5,653,466 A	8/1997	Berrios	280/760
5,660,244 A	* 8/1997	Matsuda	180/68.1
5,667,032 A	* 9/1997	Kamlukin	180/256
5,894,907 A	* 4/1999	Peter	180/374
6,129,164 A	* 10/2000	Teal et al.	180/6.2
6,185,920 B1	* 2/2001	Oxley	56/14.7
6,244,370 B1	* 6/2001	Peter	180/374
6,257,357 B1	* 7/2001	Teal et al.	180/6.2
6,325,396 B1	* 12/2001	Romig	280/98
6,354,388 B1	3/2002	Teal et al.	

FOREIGN PATENT DOCUMENTS

EP	0262285	4/1988	34/86
EP	0532068	3/1993	34/70
EP	0578884	1/1994	5/4
FR	2722641	7/1995		
JP	4-166422	* 4/1992	B60K/11/06

* cited by examiner

Primary Examiner—Árpád Fábíán Kovács

(74) *Attorney, Agent, or Firm*—Brouse McDowell; Roger D. Emerson; Timothy D. Bennett

(57) **ABSTRACT**

A riding lawn mower having zero turn capabilities has the engine mounted on the front of the frame. A drive system includes first and second hydrostatic transmissions for use in driving the back wheels. A grass bag may be mounted to the back portion of the frame and provides a counter balance to maximize the weight distribution. A discharge chute transfers cut vegetation from a mower deck to the grass bag and provides rear center discharge.

5 Claims, 3 Drawing Sheets

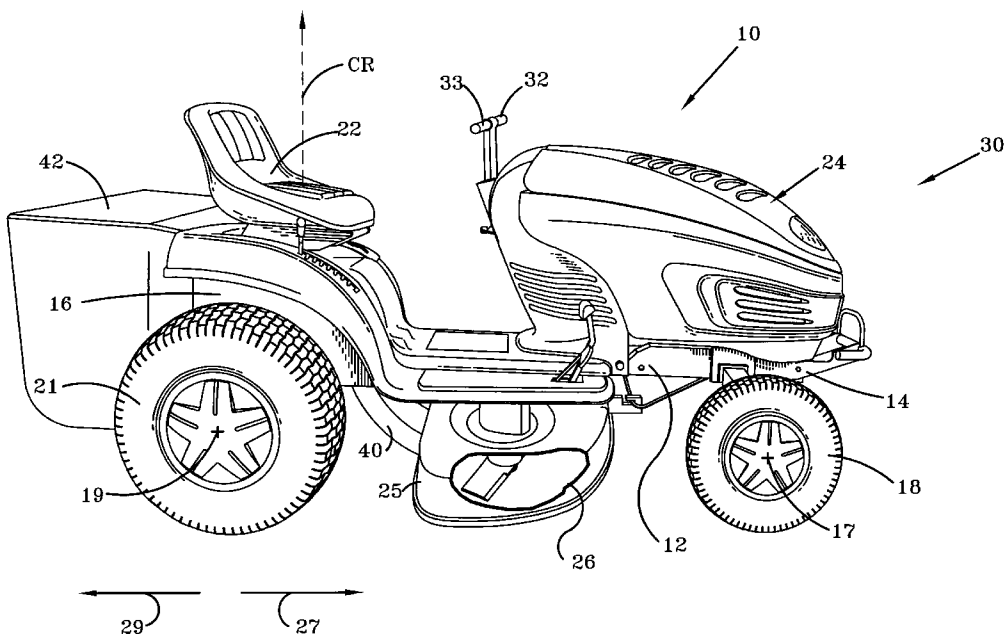

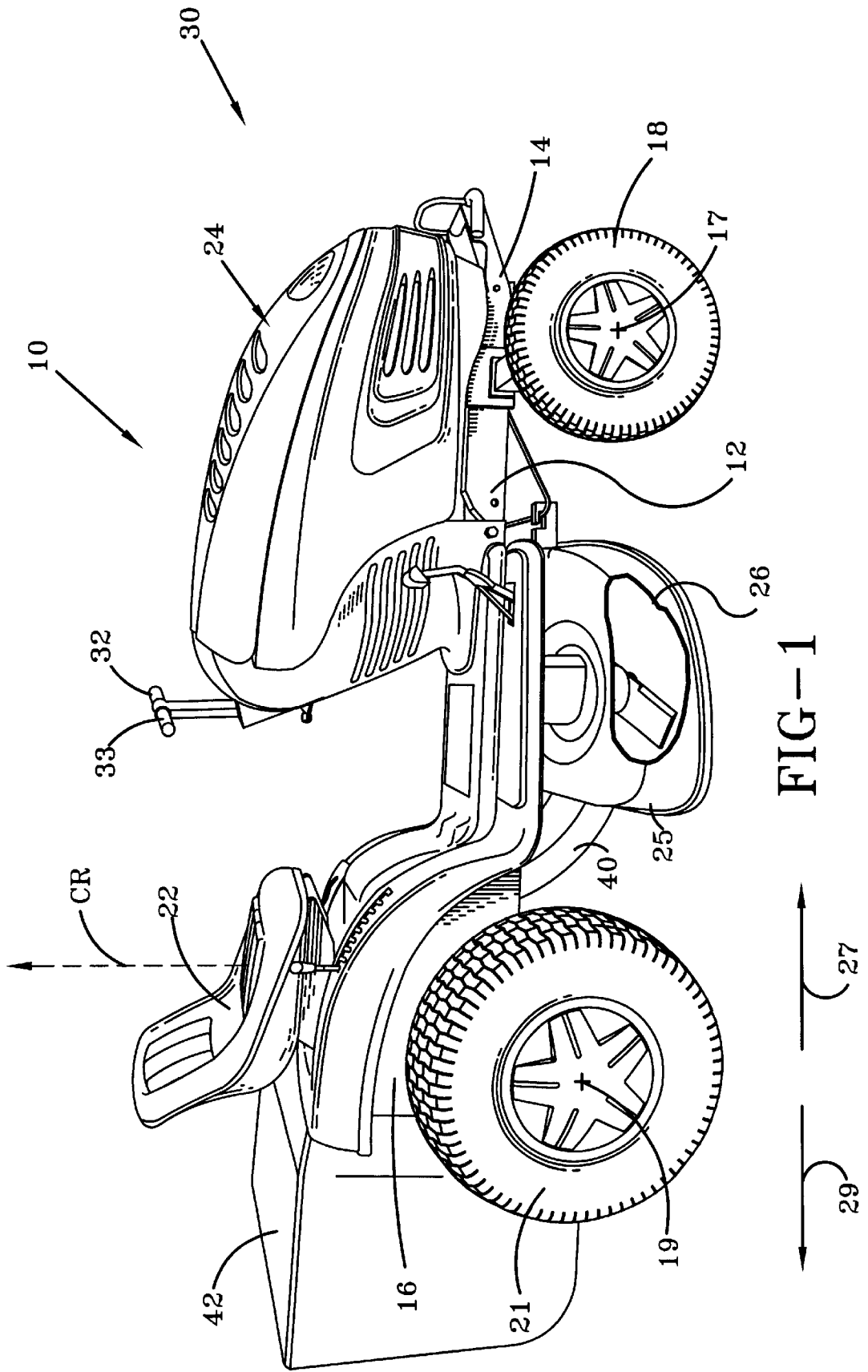

FIG-1

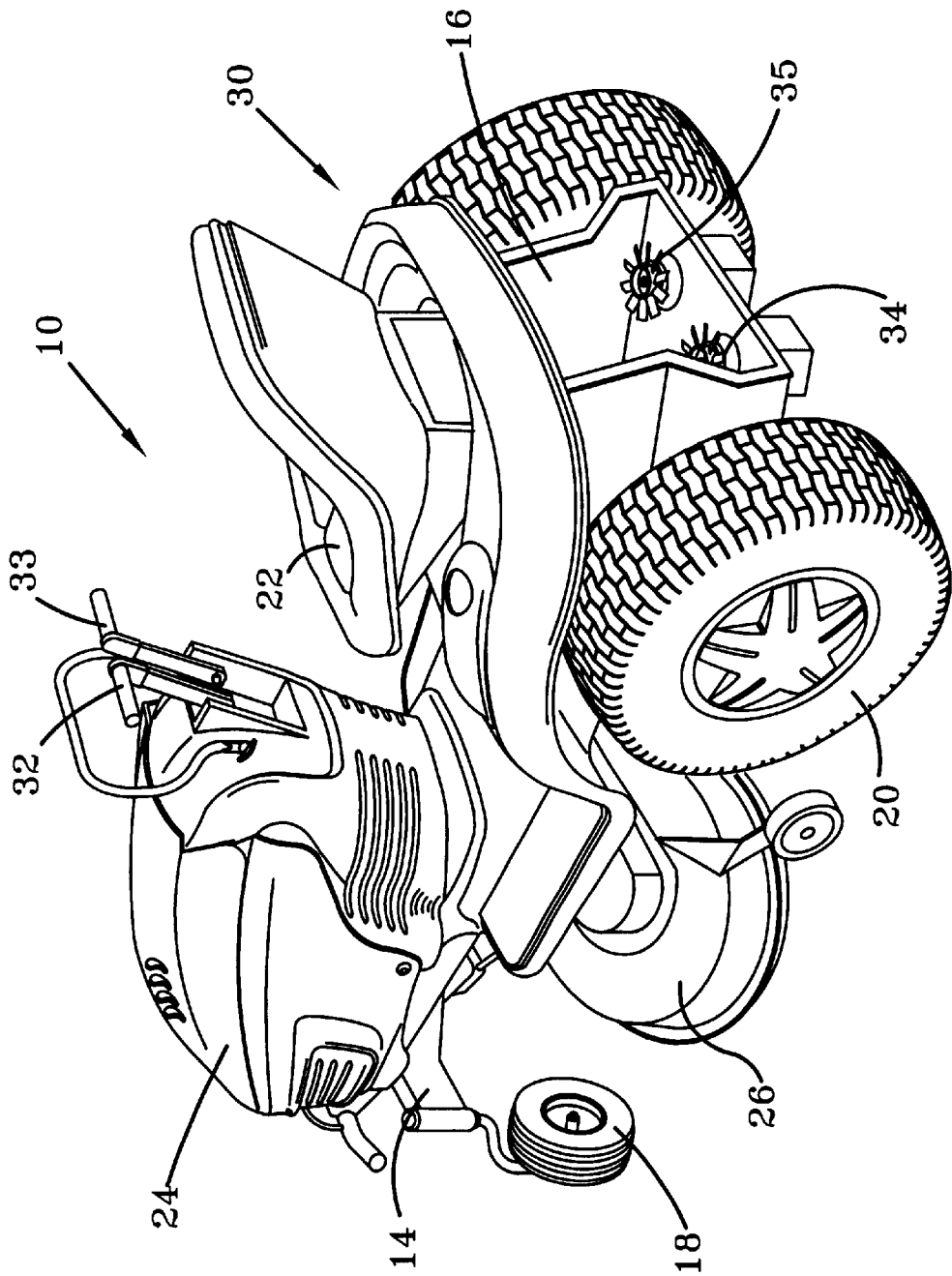

FIG-2

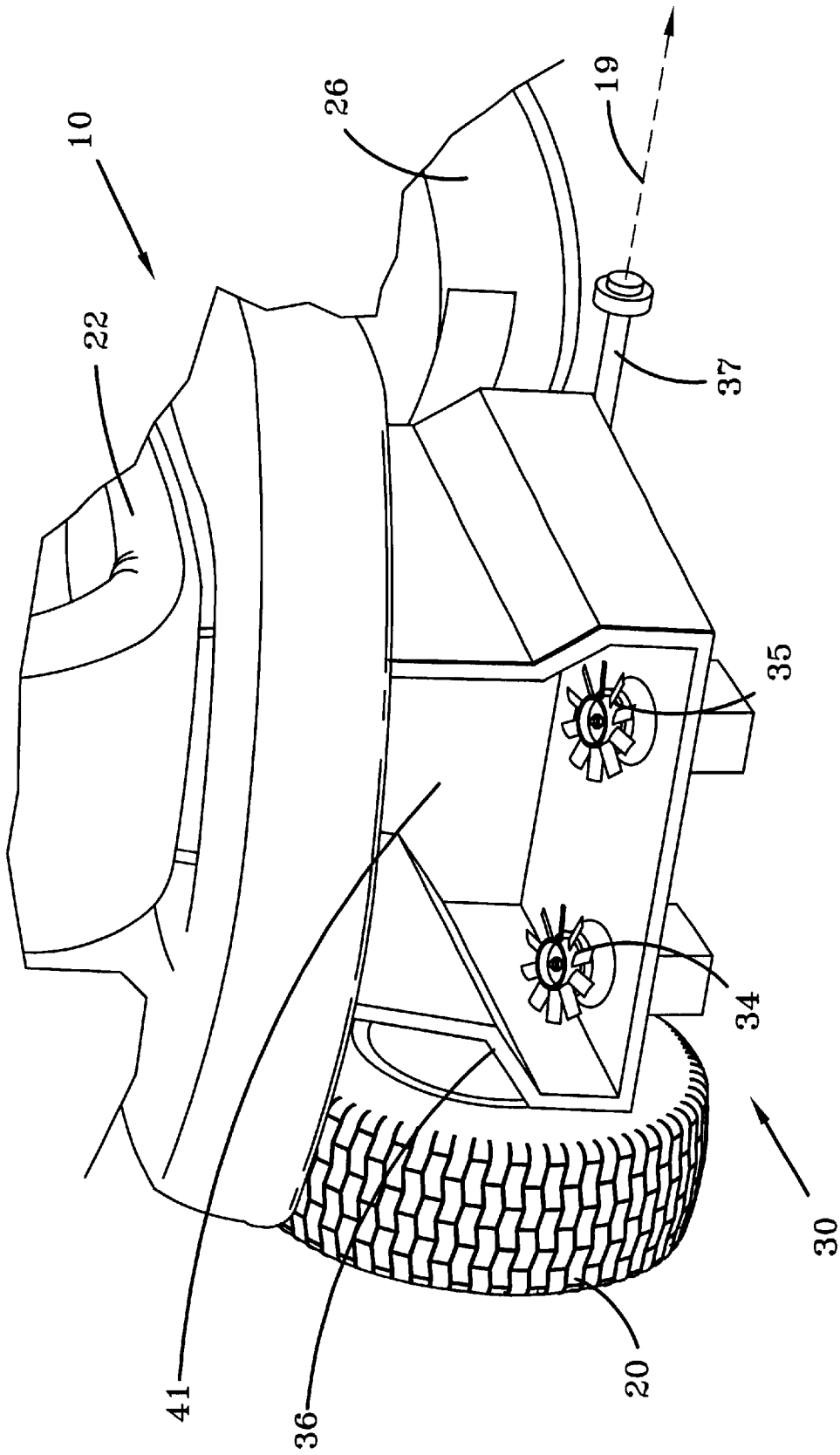

FIG-3

ZERO TURN TRACTOR WITH FRONT MOUNTED ENGINE

This Utility Patent Application claims priority from Provisional Patent Application Serial No. 60/154,061 filed Sep. 16, 1999.

BACKGROUND OF THE INVENTION

1. Field of Invention

This invention pertains to the art of methods and apparatuses for zero turn tractors, and more specifically to methods and apparatuses for a zero turn tractor having an engine mounted to the front portion of the frame.

2. Description of the Related Art

Tractors having zero radius turning capabilities are now well known in the art. They are often known as "zero turn" tractors. Typically such tractors have two drive wheels, one on each side of the tractor, and two driving controls, each of which controls one of the drive wheels. To make a zero radius turn it is necessary to drive one of the drive wheels in a forward direction while simultaneously driving the other drive wheel in a reverse direction. The desirability of such zero turn tractors continues to grow. However, one disadvantage, at least to some users, is that known zero turn tractors have engines mounted on the back of the tractor frame. This may be undesirable to some users who prefer to have the engine mounted to the front of the tractor.

Another problem with known zero turn tractors is related to the required weight distribution. Ideally, the longitudinal center of gravity is positioned over the axis of the back drive wheels—the center of rotation for a zero radius turn. This permits zero radius turns to be made most efficiently. Know tractors having zero radius turning capabilities are "back heavy." By back heavy it is meant that known zero turn tractors place the engine in the back portion of the tractor—rearward of the center of rotation. This requires counterbalancing of weight toward the front portion of the tractor in order to maintain the longitudinal center of gravity at the center of rotation. This leads to two known problems. First, the operator seat is typically positioned forward of the back wheel axle. Although this works well for its intended purpose, ideally the operator seat (and thus the operator) is placed over the center of rotation to minimize the torque felt by the operator during a zero radius turn. Often, however, moving the operator forward is still not enough counterbalance. Thus, the second known problem is to have to provide additional weight toward the front portion of the tractor. This weight is known as "dead weight" because its purpose is simply to counterbalance the engine weight. This extra weight is otherwise undesirable because it makes the tractor less efficient and more expensive.

The present invention provides a zero turn tractor having the engine placed forward of the operator seat. This permits the operator to be positioned substantially over the tractor's center of rotation. This also removes the need for dead weight. The difficulties inherent in the art are therefore overcome in a way that is simple and efficient while providing better and more advantageous results.

SUMMARY OF THE INVENTION

According to one aspect of this invention, a riding lawn mower has a frame with a pair of front wheels and a pair of back wheels operatively connected to the frame. The mower also includes a mower deck mounted to the frame and an engine to the front portion of the frame. A drive system is

used to provide power from the engine to the back wheels. This drive system provides zero turn capabilities.

According to another aspect of this invention the mower may also include a grass bag mounted to the back portion of the frame. A discharge chute transfers cut vegetation from the mower deck to the grass bag. This provides for a rear center discharge mower having zero turn capabilities.

One advantage of the present invention is that it is easy to manufacture and can be made economically.

Another advantage of the present invention is that the need for dead weight to counter balance a rear mounted engine has been eliminated.

Another advantage of this invention is that the operator is positioned on the center of rotation for zero radius turns.

Still another advantage of this invention is that the grass bag acts as a useable counter weight.

Yet another advantage of this invention is that a zero turn tractor is provided with a rear center discharge.

Still other benefits and advantages of the invention will become apparent to those skilled in the art to which it pertains upon a reading and understanding of the following detailed specification.

BRIEF DESCRIPTION OF THE DRAWINGS

The invention may take physical form in certain parts and arrangement of parts, a preferred embodiment of which will be described in detail in this specification and illustrated in the accompanying drawings which form a part hereof and wherein:

FIG. 1 is a side of a riding mower incorporating the features of this invention.

FIG. 2 is a perspective rear view of the mower of FIG. 1 shown with the grass bag removed.

FIG. 3 is a back view of the mower of FIG. 1 showing the grass bag, the discharge chute and the right rear back wheel removed to illustrate the chute opening.

DESCRIPTION OF THE PREFERRED EMBODIMENT

Referring now to the drawings wherein the showings are for purposes of illustrating a preferred embodiment of the invention only and not for purposes of limiting the same, FIGS. 1–2 shows a lawn and garden tractor **10** according to this invention. The preferred embodiment is directed to a lawn and garden tractor but the invention is applicable to other mowers, other vehicles, and other applications as well. The tractor **10** includes a frame **12** having front and back portions **14, 16** with front wheels **18** operatively mounted to the front portion **14** and back wheels **20, 21** operatively mounted to the back portion **16**. Preferably, the front wheels **18** are castor wheels to freely permit the front of the tractor **10** to pivot about the center of rotation CR during a zero radius turn. Though a pair of front wheels **18** are preferred, only a single front wheel is required for this invention. The back wheels **20, 21** are used as drive wheels to provide locomotion for the tractor. Both back wheels **20, 21** can be selectively driven in forward and rearward directions as will be disclosed further below.

With continuing reference to FIGS. 1–2, the tractor also includes an operator seat **22** and an engine **24** both mounted to the frame **12**. A drive system **30** is used to provide power from the engine **24** to the back wheels **20, 21**. The engine is also used to rotate one or more cutting blades (not shown) within a mower deck **26** that is supported from the frame **12**.

The operation of the cutting blades is well known in the art and thus will not be discussed further in this specification. The drive system **30** can be used to drive either back wheel in a first direction (for example, the first back wheel **20** in forward direction **27**) and the other back wheel in a second direction (for example, the second back wheel **21** in backward direction **29**). When the back wheels **20, 21** are driven in such opposite directions, the tractor **10** makes a zero radius turn. What is especially to be noted is that the engine **24** is mounted to the front portion **14** of the frame **12** and provides power to the drive system **30** providing zero turn capabilities. This is believed to be a first in the industry. It should also be noted that the engine **24** is positioned fully forward of the operator seat **22**. By fully forward it is meant that every component of the engine **24** is positioned forward (toward forward direction **27**) of every component of the operator seat **22**.

With reference now to FIGS. 1-3, the drive system **30** includes a pair of driving controls **32, 33** that are used to independently control the direction and speed of the first and second drive wheels **20, 21** respectively. It should be noted that any drive system **30**, including any type of transmission, that provides variable speed drive in forward and reverse (first and second) directions can be used with this invention. However, in the preferred embodiment the drive system **30** also includes first and second hydrostatic transmissions **34, 35**. The hydrostatic transmissions **34, 35** each selectively rotating first and second drive axles (only second axle **37** is visible but the first axle **36** is similar in design) respectively that are operatively connected to the first and second back wheels **20, 21** respectively. The drive axles **36, 37** are co-linear with the axis **19** of the back wheels **20, 21**. The inner workings of hydrostatic transmissions are well known in the art and thus will not be discussed here in detail. The driving controls **32, 33** are operatively connected to the hydrostatic transmissions **34, 35** respectively. Thus, to adjust the speed, direction and turning of the tractor **10**, the operator only needs to adjust the driving controls **32, 33** as desired. What is especially to be noted is that the operator seat **22** is mounted both substantially in the side to side middle of the tractor **10** and substantially over the drive axles **36, 37** (thus also over the axis **19**). Thus, the operator seat **22** (and the operator when using the seat **22**) is positioned substantially on the center of rotation CR of the tractor **10** when experiencing a zero radius turn. This is believed to be a first in the industry.

With continuing reference to FIGS. 1-3, the tractor **10** may also include a discharge chute **40** for use in transferring cut vegetation (not shown) from the mower deck **26** to a grass bag **42**. As shown, the grass bag **42** is mounted to the back portion **16** of the frame **12**. As also shown, the discharge chute **40** is operatively connected to the back end **25** of the mower deck **26** substantially at the mower deck's side to side center. For this reason the tractor **10** shown may be considered a rear center discharge riding mower. FIG. 3 shows a back view of the tractor **10** with the second back wheel **21**, the grass bag **42** and the discharge chute **40** removed. What can be seen in FIG. 3 is a chute opening **41** through which the discharge chute **40** extends. It is especially to be noted that the discharge chute **40** passes fully beneath the operator seat **22** and at least partially between the first and second hydrostatic transmissions **34, 35**. By fully beneath it is meant that over the longitudinal length of the tractor **10** that coincides with the longitudinal length of the operator seat **22**, every portion of the discharge chute **40** is positioned below the operator seat **22**. Preferably, the discharge chute **40** passes fully above the first and second

drive axles **36, 37** and fully between said first and second back wheels **20, 21**. By fully above it is meant that over the longitudinal length of the tractor **10** that coincides with the longitudinal length of the drive axles **36, 37**, every portion of the discharge chute **40** is positioned, above the drive axles **36, 37**. By fully between it is meant that over the longitudinal length of the tractor **10** that coincides with the longitudinal length of the back wheels **20, 21**, every portion of the discharge chute **40** is positioned between the back wheels **20, 21**. This positioning of tractor **10** components provides for a very direct (non-tortuous) route for the discharge chute **40** while permitting the discharge chute **40** to maintain a relatively large cross sectional area throughout its length. A rear center discharge riding mower having zero radius turning capabilities is believed to be a first in the industry.

With reference now to FIG. 1, the weight distribution of the inventive tractor **10** will now be further discussed. As noted above, known zero turn tractors are back heavy. In other words, known zero turn tractors have longitudinal centers of gravity (discounting operator weight) that are positioned closer to an axis of the back wheels than to an axis of the front wheels. This weight distribution problem with known zero turn tractors is compounded when a rear mounted grass bag is used because the back heaviness is only increased. The tractor **10** of this invention, on the other hand, has a longitudinal center of gravity (discounting operator weight) that is positioned closer to an axis **17** of the front wheels **18** than to the axis **19** of the back wheels **20, 21**. This eliminates the need to move the operator seat **22** forward of the center of rotation CR and also eliminates the need to add dead weight to the front portion **14** of the frame **12**. With this in mind, it should be noted that the grass bag **42** serves not only to collect cut vegetation but also as useful (as opposed to dead) counter weight (rearward of the back wheel axis **19**) to position the center of gravity substantially at the center of rotation CR. Thus, while rear mounted grass bags make known zero turn tractors even farther out of weight balance, the grass bag **42** mounted to the tractor **10** of this invention acts as a counterbalance to improve the weight distribution.

The preferred embodiments have been described, hereinabove. It will be apparent to those skilled in the art that the above methods may incorporate changes and modifications without departing from the general scope of this invention. It is intended to include all such modifications and alterations in so far as they come within the scope of the appended claims or the equivalents thereof.

What is claimed is:

1. A vehicle comprising:

- a frame having front and back portions;
- at least a first front wheel operatively mounted to said front portion of said frame;
- first and second back wheels operatively mounted to said back portion of said frame;
- an engine operatively mounted to said front portion of said frame;
- a drive system for use in providing power from said engine to said first and second back wheels, said drive system adapted to selectively drive said first back wheel in a first direction while simultaneously driving said second back wheel in a second direction thereby providing zero turn capabilities;
- a mower deck including at least a first cutting blade and operatively connected to said frame, said engine providing power to rotate said at least first cutting blade;
- an operator seat mounted to said frame, said engine being positioned fully forward of said operator seat; and,

5

- a discharge chute operatively connected to said mower deck, wherein said discharge chute passes fully beneath said operator seat.
- 2. The vehicle of claim 1, wherein said discharge chute passes fully between said first and second back wheels.
- 3. The vehicle of claim 2 further comprising:
said drive system including first and second hydrostatic transmissions for use in driving said first and second back wheels respectively; and,
a grass bag mounted to said back portion of said frame.

6

- 4. The vehicle of claim 3 wherein said first and second hydrostatic transmissions have first and second drive axles respectively operatively connected to said first and second back wheels respectively, said discharge chute passing fully above said first and second drive axles.
- 5. The vehicle of claim 4 wherein said at least a first front wheel comprises:
first and second front castor wheels.

* * * * *