

FIG. 1

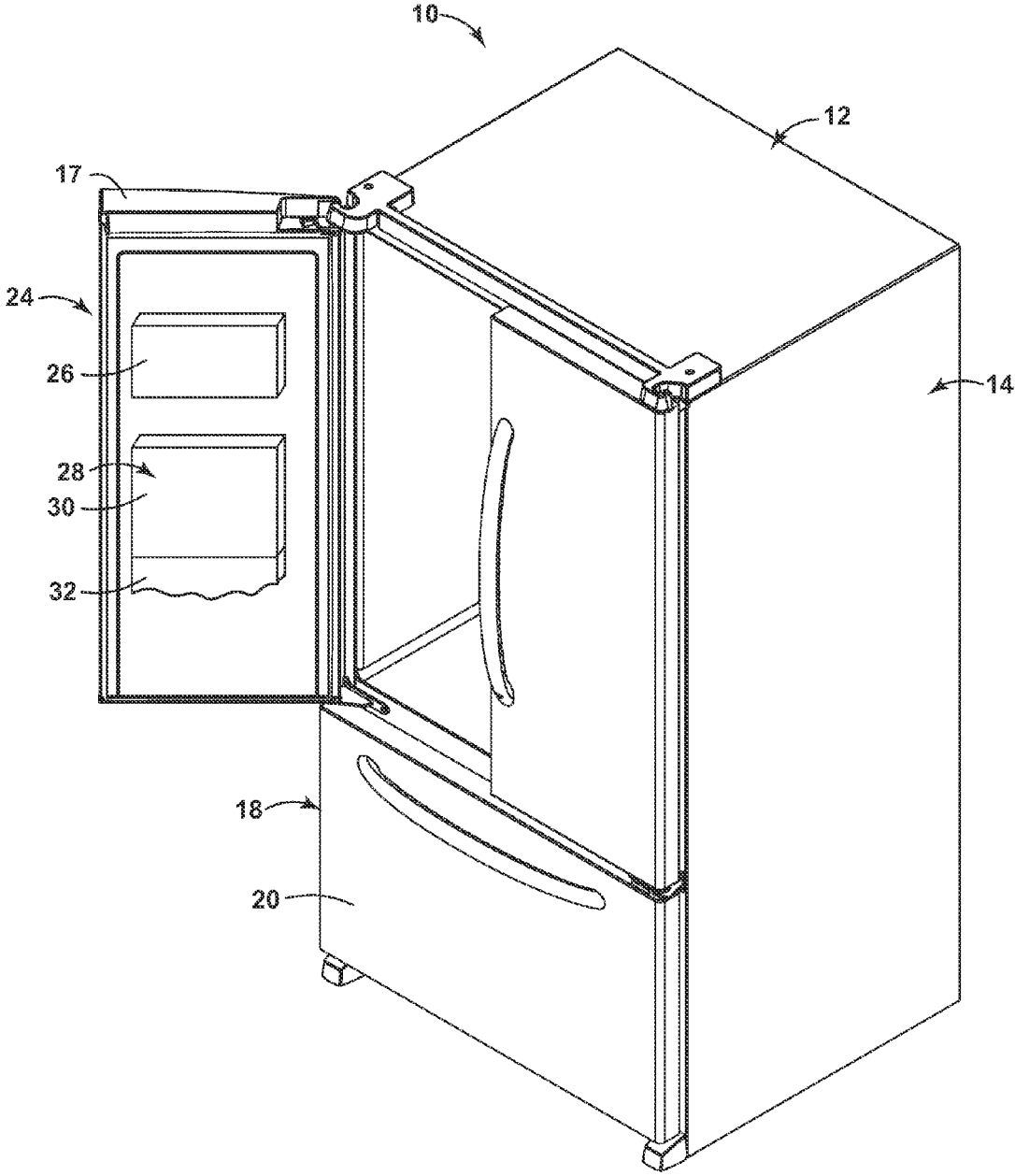

FIG. 2

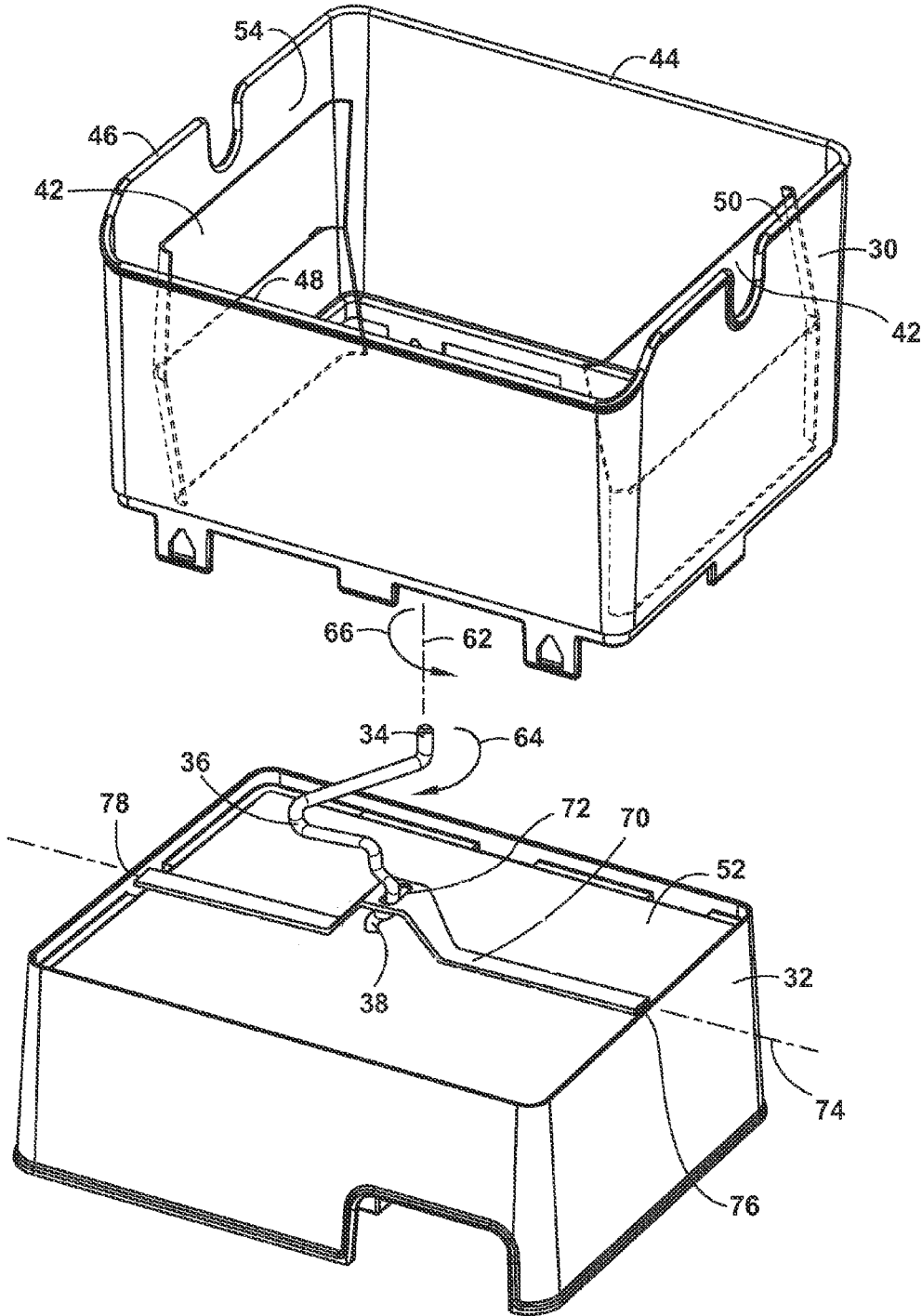

FIG. 3

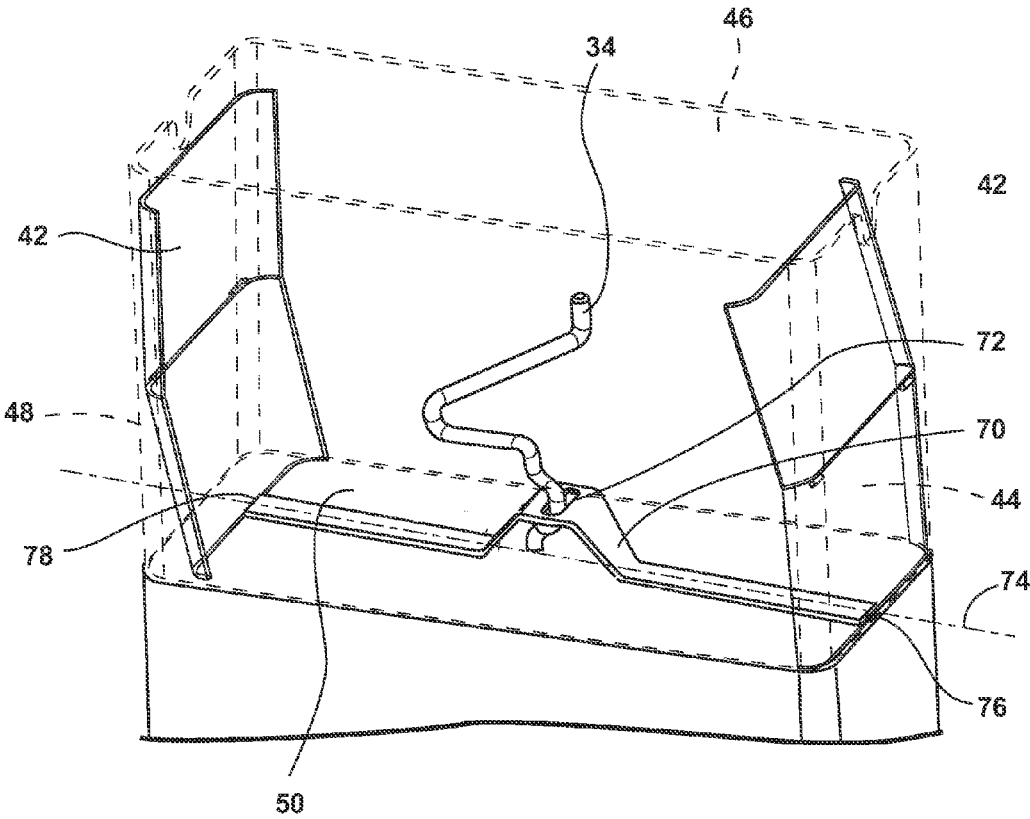

FIG. 4

STIR STICK AND BREAKER WALLS FOR AN ICE CONTAINER

CROSS REFERENCE TO RELATED APPLICATIONS

[0001] This application is a Continuation Application of and claims priority to U.S. patent application Ser. No. 14/012,099, entitled "STIR STICK AND BREAKER WALLS FOR AN ICE CONTAINER" filed Aug. 28, 2013, pending, which application is hereby incorporated by reference in its entirety.

BACKGROUND OF THE DISCLOSURE

[0002] Ice makers may be included with refrigerators, or may be stand-alone units. In general, the ice maker includes a water source, a cooling source, a mold, and an ejecting mechanism. Water is added to the mold, and the cooling source removes heat from the water to lower the temperature below freezing, at which time ice cubes are formed. Once the cubes have formed, the ejecting mechanism operates to remove or eject the formed cubes from the molds, at which point new water can be added and the process repeated.

[0003] The ejected ice cubes are generally directed towards an ice container or ice storage bin. In refrigerators and in stand-alone units, the ice container is located generally adjacent the ice maker so that the formed ice cubes do not have to travel a long distance from the ice maker. Furthermore, the cooled air of the cooling source may be used to direct cold air to the ice container to keep the ice cubes in the ice container below freezing to prevent the cubes from melting.

[0004] In a refrigerator, the ice maker and ice container may be positioned on the inside of a refrigerator compartment or freezer compartment door, with the ice maker generally positioned above the ice container such that gravity causes the formed ice cubes to fall from the ice maker to the ice container. The cooling source in a refrigerator may be cold air that is directed from the freezer compartment to the ice maker. The cooling source may also be any other cooling source known to those skilled in the art such as additional evaporators. The below-freezing air from the freezer removes enough heat to freeze the water in the ice molds. The same air may also be passed into the ice container to prevent the cubes from melting.

[0005] However, as the amount of cubes accumulate in the ice container, it becomes more difficult to ensure that all of the cubes are at a temperature to prevent melting. If air is passed into the container, it may not reach cubes that are located below other cubes. Warm air may also be introduced to the ice container if a door is opened or the ice container is opened to retrieve ice from the container. In any sense, the cubes in the container may experience some melting and refreezing. The melting and refreezing of the cubes can cause multiple cubes to freeze together, forming ice clumps. Sublimation may also lead to ice cubes clumping. The ice clumps are too large to fit through a dispenser opening, and therefore, it is important to provide means to prevent clumping, or to break up the clumps.

[0006] Stir sticks have been added to ice containers to aid in preventing and breaking up ice clumps. The stir sticks are configured to rotate within an ice container to move the cubes and to direct the cubes towards a dispensing area. However, the size and shape of ice containers do not make

it feasible for the stir sticks to reach the full area within the containers. Therefore, there are areas within the container that still include conditions that allow the formation of ice clumps.

SUMMARY OF THE PRESENT DISCLOSURE

[0007] One object, feature and/or advantage of the present disclosure includes an apparatus and method of preventing the formation of ice clumps in an ice container.

[0008] Another object, feature and/or advantage of the present disclosure includes an apparatus and method for breaking up clumps of ice that have formed in an ice container.

[0009] These and other aspects, objects, and features of the present disclosure will be understood and appreciated by those skilled in the art upon studying the following specification, claims, and appended drawings. The present disclosure is not to be limited to or by these objects, features, and advantages. No single embodiment need provide each and every object, feature, or advantage.

[0010] According to one aspect of the present disclosure includes an apparatus that includes a stir stick providing cam action to a cam rod, which in turn provides rocking action to a pair of breaker walls.

[0011] Still another aspect of the present disclosure provides a method for driving a combination of a bent stir stick and a pair of breaker walls to provide mechanical action to break up ice clumps that have formed in an ice container.

[0012] These and other aspects, objects, and features of the present disclosure will be understood and appreciated by those skilled in the art upon studying the following specification, claims, and appended drawings. The present disclosure is not to be limited to or by these objects, features, and advantages. No single embodiment need provide each and every object, feature, or advantage.

BRIEF DESCRIPTION OF THE DRAWINGS

[0013] FIG. 1 is a front elevation view of a bottom mount refrigerator.

[0014] FIG. 2 is a perspective view of the refrigerator of FIG. 1 with the refrigerator doors open and showing an ice maker and ice container.

[0015] FIG. 3 is a partial exploded view of an ice container according to the present disclosure.

[0016] FIG. 4 is a perspective isometric view of the ice container according to the present disclosure.

DETAILED DESCRIPTION OF EMBODIMENTS

[0017] For purposes of description herein, the terms "upper," "lower," "right," "left," "rear," "front," "vertical," "horizontal," and derivatives thereof shall relate to the disclosure as oriented in FIG. 1. However, it is to be understood that the disclosure may assume various alternative orientations, except where expressly specified to the contrary. It is also to be understood that the specific devices and processes illustrated in the attached drawings, and described in the following specification are simply exemplary embodiments of the inventive concepts defined in the appended claims. Hence, specific dimensions and other physical characteristics relating to the embodiments disclosed herein are not to be considered as limiting, unless the claims expressly state otherwise.

[0018] As used in this disclosure, the term “cam action” is defined as all of the parts necessarily included in a system that changes a rotational movement input into an output of linear translational movement.

[0019] Referring FIG. 1 is a front elevation view of a bottom mount refrigerator 10. The bottom mount refrigerator 10 includes a cabinet 12 encapsulating the compartments of the refrigerator 10. As shown in FIG. 1, the upper compartment is a refrigerator or fresh food compartment 14. First and second doors 16, 17 provide access to the interior of the refrigerator compartment 16. A dispenser 22 is positioned on one of the doors 17 of the refrigerator compartment 16. The dispenser 22 may be a water dispenser, ice dispenser, other beverage dispenser, or some combination thereof. Furthermore, the dispenser 22 may be placed on any door 16, 17, 20 of the refrigerator 10, or the dispenser 22 may be placed within one of the compartments of the refrigerator 10. For example, the dispenser 22 may be placed at one of the interior walls of the refrigerator compartment 16, thus being part of the cabinet 12. The placement of the dispenser 22 is not to limit the present disclosure. Positioned generally below the refrigerator compartments 14 is a freezer compartment 18. A freezer door 20 provides access to the freezer compartment 18. The freezer door 20 of FIG. 1 is shown as a drawer-type door. However, the present disclosure contemplates that the freezer door 20 may be a drawer or hinge door for providing access to the interior of the freezer compartment 18.

[0020] It should also be appreciated, that while FIGS. 1 and 2 show a bottom mount style refrigerator 10, the present disclosure contemplates that any style of refrigerator be included as part of the disclosure. The figures merely depict one example of a type of refrigerator that can be used with the present disclosure.

[0021] FIG. 2 is a perspective view of the bottom mount refrigerator 10 of FIG. 1 having the refrigerator door 17 opened and the refrigerator door 16 removed to show an interior of the refrigerator 10. In addition, the freezer door 20 is shown to be a drawer that can be slid open to provide access to the freezer compartment 18. FIG. 2 shows an ice making system 24, which is operably connected to a dispenser 22 of the refrigerator 10. As shown in FIG. 2, the ice making system 24 is positioned on the inside of the refrigerator door 17. However, as mentioned above regarding the dispenser 22, the ice making system 24 can be positioned generally anywhere with respect to the refrigerator 10. For example, the ice making system can be positioned in or at an upper portion of the refrigerator compartment 14, on a side wall of the refrigerator compartment 14, or even possibly in the freezer compartment 18. The location of the ice making system 24 is not to be limiting to the present disclosure.

[0022] The ice making system 24 shown in FIG. 2 includes an ice maker 26 and an ice container 28. The ice maker 26 can be any style or configuration of ice maker that produces ice cubes (not shown). The ice container 28 is operably connected to the ice maker 26 such that ice cubes made in the ice maker 26 are dispensed or directed into the ice container 28. The size of the ice container 28 should be sufficient enough to contain or hold an amount of ice sufficient for a user or owner. Furthermore, it should be contemplated that both the ice maker 26 and the ice container 28 may be removed from the refrigerator 10. Thus, the present disclosure contemplates that the ice making system 24 be a modular ice making system. Furthermore, it should

be appreciated that only the ice container 28 may be removable from the refrigerator 10. Also shown in FIG. 2, the ice container 28 generally includes an upper portion 30 and a lower portion 32. The portions will be discussed in greater detail below. However, the upper and lower portions 30, 32 of the ice container 28 generally are constructed such that they comprise a single unit, and are not removed separately when the ice container is removed from the refrigerator 10.

[0023] FIG. 3 is a partial exploded view of an ice container 28 according to the present disclosure. As shown in FIG. 3, the ice container 28 is generally a rectangular-shaped container. The rectangular shape of the ice container 28 of the present disclosure allows for a slimmer ice container 28 that will take up less useable space within the refrigerator 10. However, the present disclosure contemplates that the ice container 28 comprises generally any shape, including but not limited to oval shapes or any other geometrical shape that may allow for the ice container to hold a predetermined amount of ice, while taking up the least amount of space as possible within the refrigerator. In addition, the shape of the lower or bottom portion 32 of the ice container 28 may be the same or different than the shape of the upper portion 30 of the ice container 28. However, the upper and lower portions 30, 32 should be connectable in some manner.

[0024] Positioned within the ice container and generally near the center of the ice container is a stir stick 34. The stir stick is a rod-shaped member that can be rotated to move or displace the ice within the ice container 28. The movement of the ice cubes in the ice container 28 aids in preventing the ice cubes from melting or clumping, while also providing or aiding movement of the cubes towards an aperture 42 in the container 28 that dispenses the ice cubes from the ice container into a cup or other container. The stir stick 34 includes one or more bent portions 36 along the length of the stir stick. The bent portion provides greater area of the stir stick 34 as it rotates in the ice container 28. Furthermore, the stir stick 34 includes a generally vertical portion at the bottom 38 of the stir stick for extending into the bottom portion 32 of the ice container 28 and connecting to a motor 56. The motor may be any type of motor that can attach to the stir stick to provide rotation of the stir stick within the ice container 28.

[0025] The upper portion 30 of the ice container 28, as shown in FIG. 3, includes a first wall 44, second wall 46, third wall 48, fourth wall 50, and a bottom floor or wall 52, with corners 54 formed at the intersections of the walls. There may be breaker walls 42 attached to the first wall 44 and the third wall 48. The breaker walls 42 may be attached such that they hinge at or near the midpoint of the breaker walls 42 and near the midpoint of the first wall 44 and the third wall 48. The attachment one of the breaker walls 42 and the first wall 44 may be any attachment that would allow for a hinge action between the breaker wall 42 and the first wall 44, including but limited to a snap fit or a pin attachment. The attachment of another of the breaker walls 42 with the third wall 48 may be accomplished in the same way.

[0026] The bottom wall 52 may actually be part of the bottom or lower member 32 of the ice container 28. The bottom wall 52 includes the aperture 42 for dispensing the ice, and therefore, may include a crusher or crushing mechanism 40 positioned therein. As noted above, the bottom 38 of the stir stick 34 may extend through the aperture 42 as well to connect to the motor or other rotating means. While the stir stick is shown to be positioned generally in the center

of the bottom wall 52, it should be appreciated that the stir stick can be positioned anywhere in the bottom wall to provide for the greatest amount of reach of the bent portions 36 of the stir stick 34.

[0027] While the stir stick 34 is configured to rotate, rotation alone may not allow for the bent portions 36 of the stir stick 34 to reach into the corners 54 of the ice container 28. Therefore, the ice at this location may begin to melt and/or clump together. Thus, the present disclosure contemplates that the stir stick 34 may be coupled with a cam rod 70. The cam rod 70 may have a slot 72 such that as the stir stick is rotated, the cam rod remains in the center of ice bin along an axis of translation 74. The stir stick 34 may be allowed to move within the slot 72 in a direction normal to the axis 74, but the rotational movement in the direction along the axis 74 translates the cam rod 70 along the axis 74, creating a cam action between the stir stick 34 and the cam rod 70.

[0028] Looking now at FIG. 4, the cam rod 70 has two ends 76 and 78. The ends 76 and 78 may be coupled with the breaker walls 42 near the bottom of the breaker walls 42, but in any case at some distance from the attachment of the breaker walls 42 to the first wall 44 and the third wall 48. The linear movement of the cam rod 70 when coupled with the breaker walls 42 at a distance from the attachment to the walls 44 and 48, may induce a rocking motion of the breaker walls 42. The rocking motion of the breaker walls 42 may allow for disturbance of the ice in edges and corners of the ice container 28 that simple rotation of the stir stick 34 may not be able to.

[0029] The cam rod 70 and the breaker walls 42 may be coupled in any fashion to allow for movement in two directions. This may be a snap on the ends 76 and 78 with a corresponding receiver portion on the breaker walls. It may also include a snap on the breaker walls 42 with a corresponding receiver portion on the ends 76 and 78. There may also be springs (not shown) between the walls 44 and 48 and the breaker walls 42 that bias the breaker walls toward the center of the ice container 28. The cam rod 70 may simply push on the breaker walls 42 against the springs, and the spring action returns the breaker walls 42 to their biased position. There may be dimples (not shown) on the ends 76 and 78 that interact with the breaker walls 42 such that the cam rod 70 is inserted through a hole in the breaker walls 42 into a position where there is one or more dimples on either side of the breaker walls 42 that provide the impetus for the movement of the breaker walls 42. Or there could be any other configuration known to a person having skill in the art to couple the cam rod 70 and the breaker walls 42 to allow for the movement described.

[0030] To break ice clumps and to prevent freeze up of ice in the ice container 28, the location of the ice container 28 and ice making system 24 should be determined. Thus, the location of the ice making system 24 may determine the shape of the ice container 28. As noted above, the shape of the ice container shall be such that the least amount of useable space within the refrigerator 10 is used by the ice container. Once the shape of the ice container 28, and more particularly the upper portion 30 of the ice container 28, has been determined, the shape 34 of the stir stick should be determined. The shape of the stir stick 34 will be determined on the shape of the ice container, such that the bends 36 of the stir stick 34 shall reach as great amount of area within the ice container as possible. The shape of the bend in the stir

stick that provides the cam action to the cam rod 70 should then be calculated to allow for enough movement of the breaker walls 42. Once these factors have been determined, the ice container can be assembled.

[0031] Other variations of the above disclosure may be utilized as well. For instance, there may be no stir stick. In this case, the cam rod may be driven directly by a motor, or one or more motors may drive the walls directly. There also may be breaker walls on all four walls of the ice bin. In this case there may be two cam rods that drive the two pairs of breaker walls.

[0032] The foregoing description has been presented for purposes of illustration and description, and is not intended to be an exhaustive list or to limit the disclosure to the precise forms disclosed. It is contemplated that other alternative processes obvious to those skilled in the art are considered to be included in the disclosure. The description is merely examples of embodiments. For example, the shape of the stir stick 34 may be varied depending on the shape of the ice container. Furthermore, the location of the motor, stir stick, apertures, cam rod, breaker walls and the like may also be varied according to the size and shape of the ice container. It should be appreciated that the configuration of the stir stick, cam rod, breaker walls, and motor within the ice container as described above are but one possible configuration for providing oscillation, gyration, and rotation of the stir stick within the ice container. It is understood that many other modifications, substitutions, and/or additions may be made, which are within the intended spirit and scope of the disclosure. From the foregoing, it can be seen that the present disclosure accomplishes at least all of the stated objections.

[0033] It will be understood by one having ordinary skill in the art that construction of the described disclosure and other components is not limited to any specific material. Other exemplary embodiments of the disclosure disclosed herein may be formed from a wide variety of materials, unless described otherwise herein.

[0034] For purposes of this disclosure, the term "coupled" (in all of its forms, couple, coupling, coupled, etc.) generally means the joining of two components (electrical or mechanical) directly or indirectly to one another. Such joining may be stationary in nature or movable in nature. Such joining may be achieved with the two components (electrical or mechanical) and any additional intermediate members being integrally formed as a single unitary body with one another or with the two components. Such joining may be permanent in nature or may be removable or releasable in nature unless otherwise stated.

[0035] It is also important to note that the construction and arrangement of the elements of the disclosure as shown in the exemplary embodiments is illustrative only. Although only a few embodiments of the present innovations have been described in detail in this disclosure, those skilled in the art who review this disclosure will readily appreciate that many modifications are possible (e.g., variations in sizes, dimensions, structures, shapes and proportions of the various elements, values of parameters, mounting arrangements, use of materials, colors, orientations, etc.) without materially departing from the novel teachings and advantages of the subject matter recited. For example, elements shown as integrally formed may be constructed of multiple parts or elements shown as multiple parts may be integrally formed, the operation of the interfaces may be reversed or otherwise

varied, the length or width of the structures and/or members or connector or other elements of the system may be varied, the nature or number of adjustment positions provided between the elements may be varied. It should be noted that the elements and/or assemblies of the system may be constructed from any of a wide variety of materials that provide sufficient strength or durability, in any of a wide variety of colors, textures, and combinations. Accordingly, all such modifications are intended to be included within the scope of the present innovations. Other substitutions, modifications, changes, and omissions may be made in the design, operating conditions, and arrangement of the desired and other exemplary embodiments without departing from the spirit of the present innovations.

[0036] It will be understood that any described processes or steps within described processes may be combined with other disclosed processes or steps to form structures within the scope of the present disclosure. The exemplary structures and processes disclosed herein are for illustrative purposes and are not to be construed as limiting.

[0037] It is also to be understood that variations and modifications can be made on the aforementioned structures and methods without departing from the concepts of the present disclosure, and further it is to be understood that such concepts are intended to be covered by the following claims unless these claims by their language expressly state otherwise.

What is claimed is:

1. An in-door ice container for a refrigerator comprising:
 - a base removably attached to a refrigerator door;
 - an upper portion coupled to the base, the upper portion comprising at least one wall and defining an ice storage volume and an axis of translation;
 - a stir stick rotatably mounted to the base having an upper portion comprising a cam portion and an ice agitation portion, and a lower portion operatively coupled to a motor, wherein the upper portion is disposed within the ice storage volume, and the lower portion is disposed below the ice storage volume;
 - a cam rod slidably disposed along the axis of translation within the ice storage volume and operatively coupled with the cam portion; and
 - a breaker wall rotatably attached at least one wall and within the ice storage volume and operatively coupled with the cam rod.
2. The in-door ice container of claim 1, wherein the base has a top wall, and the upper portion is disposed above the base
3. The in-door ice container of claim 2, wherein the top wall is the floor of the ice storage volume
4. The in-door ice container of claim 3, wherein the stir stick is mounted through the top wall.
5. The in-door ice container of claim 1, wherein the breaker wall is attached near the middle of the breaker wall.
6. The in-door ice container of claim 1, further comprising a second wall parallel to the at least one wall
7. The in-door ice container of claim 6, further comprising a second breaker wall wherein the breaker walls are rotatably attached near the middle of the walls.
8. The in-door ice container of claim 1, wherein the cam portion and the ice agitation portion are the same.

9. The in-door ice container of claim 1, wherein the movement of the breaker wall is synched with the rotation of the stir stick.

10. The in-door ice container of claim 1, wherein the motor is mounted to the refrigerator door.

11. A refrigerator with an icemaker and ice storage, comprising:

- a cabinet with a door providing selective access to a refrigerator compartment within the cabinet;
- an icemaker disposed within the refrigerator compartment;
- an ice bin to store ice made in the icemaker comprising a perimeter wall and a bottom wall, disposed within the cabinet and located below the ice maker; and
- a stir stick extending through the bottom wall and is configured to rotate about an axis of rotation;
- a cam rod coupled to the stir stick and configured to accept a rotational motion input from the stir stick and deliver a linear motion output;
- at least one breaker wall on the perimeter wall and coupled with the cam rod;
- wherein the at least one breaker wall is configured accept linear motion from the cam rod and agitate ice within the ice bin.

12. The refrigerator of claim 11, wherein the ice bin is disposed on the door.

13. The refrigerator of claim 11, wherein the stir stick is rotated by a motor.

14. The refrigerator of claim 12, wherein the motor is located on the door.

15. The refrigerator of claim 11, wherein the at least one breaker wall is hingedly attached to the perimeter wall.

16. The refrigerator of claim 15, wherein the at least one breaker wall is attached to the perimeter wall about half the height of the perimeter wall.

17. A method of breaking up ice within an ice container of a refrigerator, the method comprising:

- providing an ice bin including perimeter wall defining an ice storage volume;
- providing a stir stick operably connected to the ice bin, the stir stick extending into the ice containing volume and comprising a plurality of bends along its length;
- providing a cam rod coupled with the stir stick;
- providing at least one breaker wall coupled with the cam rod and hingedly attached to the perimeter wall;
- rotating the stir stick within the ice bin;
- translating the cam rod along a translation axis;
- rocking the first breaker wall on the first wall to reach one end of the ice bin; and
- rocking the second breaker wall on the second wall to reach another end of the ice bin.

18. The method of claim 17, wherein the at least one breaker wall is a first breaker wall coupled with a first end of the cam rod, and further comprising a second breaker wall coupled with a second end of the cam rod and hingedly attached to the perimeter wall opposite the first breaker wall.

19. The method of claim 18, wherein the ice bin is disposed on a door of the refrigerator.

20. The method of claim 18, wherein the rocking the first breaker wall and the rocking the second breaker wall steps are synchronized with the rotating the stir stick step.

* * * * *