



US 20060179650A1

(19) **United States**

(12) **Patent Application Publication**
Hiraguchi

(10) **Pub. No.: US 2006/0179650 A1**

(43) **Pub. Date: Aug. 17, 2006**

(54) **MAGNETIC TAPE CASSETTES AND PROCESSES FOR PRODUCING THEM**

(30) **Foreign Application Priority Data**

Jul. 2, 2001 (JP) 2001-200695

(75) Inventor: **Kazuo Hiraguchi**, Kanagawa (JP)

Publication Classification

Correspondence Address:
SUGHRUE MION, PLLC
2100 PENNSYLVANIA AVENUE, N.W.
SUITE 800
WASHINGTON, DC 20037 (US)

(51) **Int. Cl.**
G11B 23/113 (2006.01)
B28B 5/00 (2006.01)
(52) **U.S. Cl.** **29/806; 264/241**

(73) Assignee: **FUJI PHOTO FILM CO., LTD.**

(57) **ABSTRACT**

(21) Appl. No.: **11/372,077**

The magnetic tape cassette has a base with an opening for forming a transparent window and a transparent resin-made window member to be installed in said opening. The window member is provided with an engaging unit which is to be fitted into the base at an angle and the base is provided with an engaging portion that is formed at an angle in correspondence to the engaging unit and the window member is installed in the opening by being fitted in at an angle.

(22) Filed: **Mar. 10, 2006**

Related U.S. Application Data

(62) Division of application No. 10/183,372, filed on Jun. 28, 2002, now Pat. No. 7,035,048.

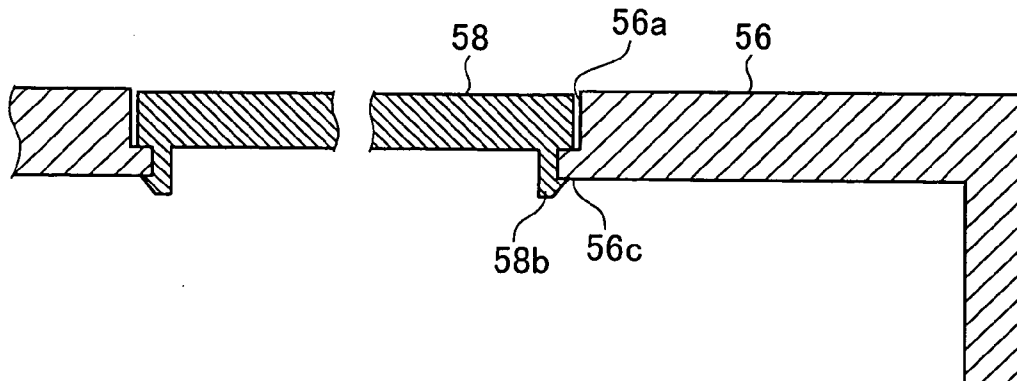

FIG. 1

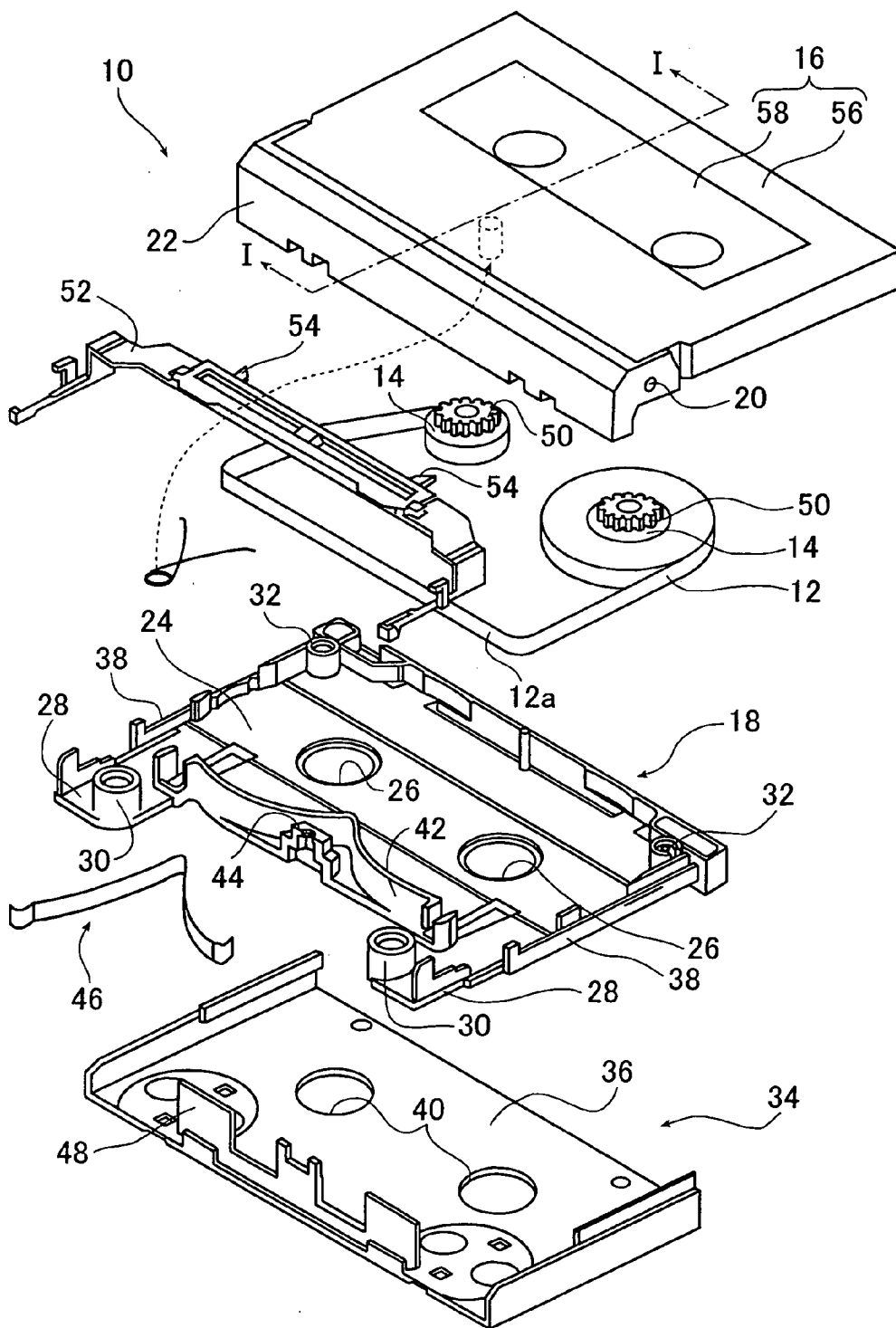

FIG. 2

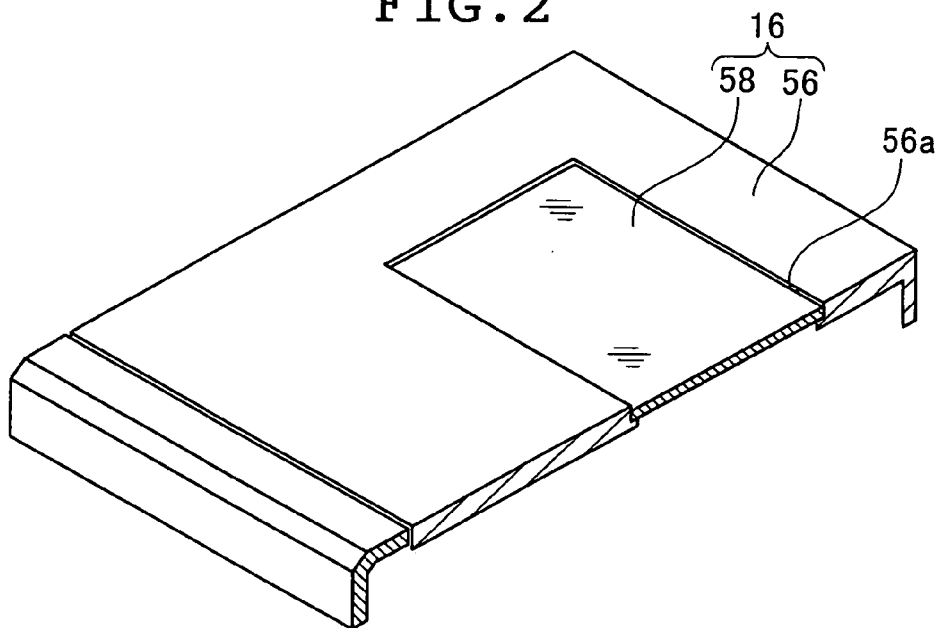

FIG. 3

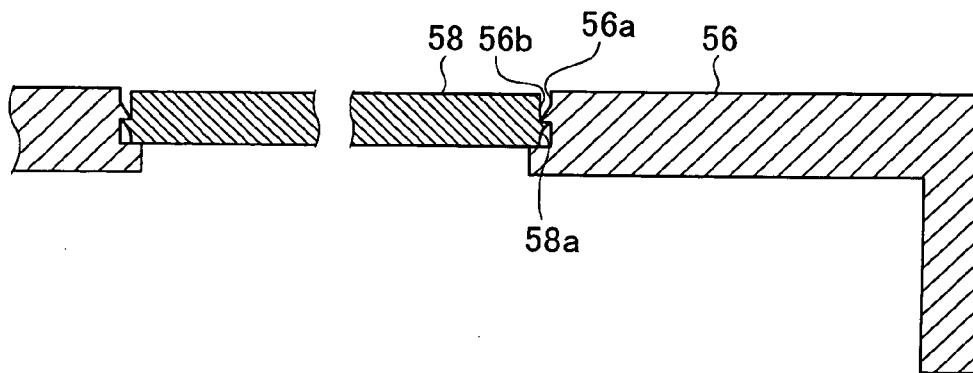

FIG. 4A

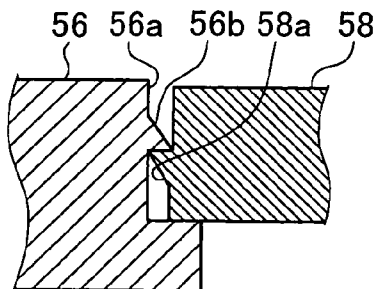

FIG. 4B

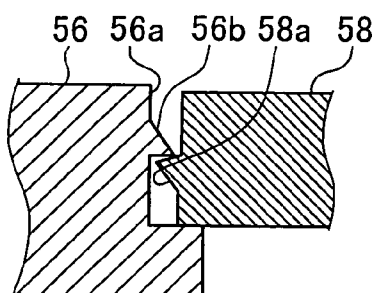

FIG. 5

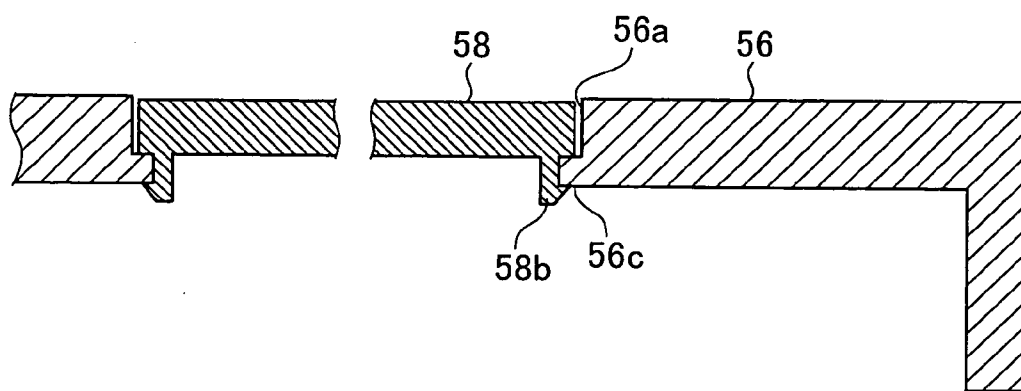

FIG. 6A

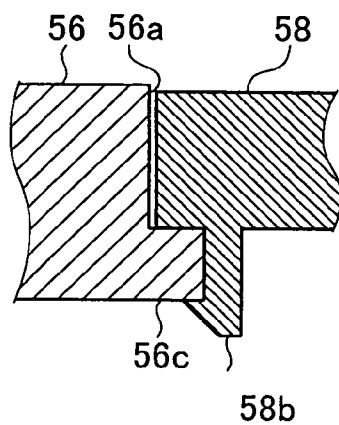

FIG. 6B

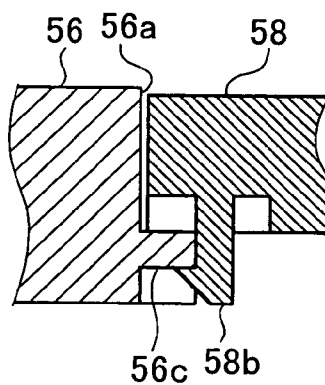

FIG. 7

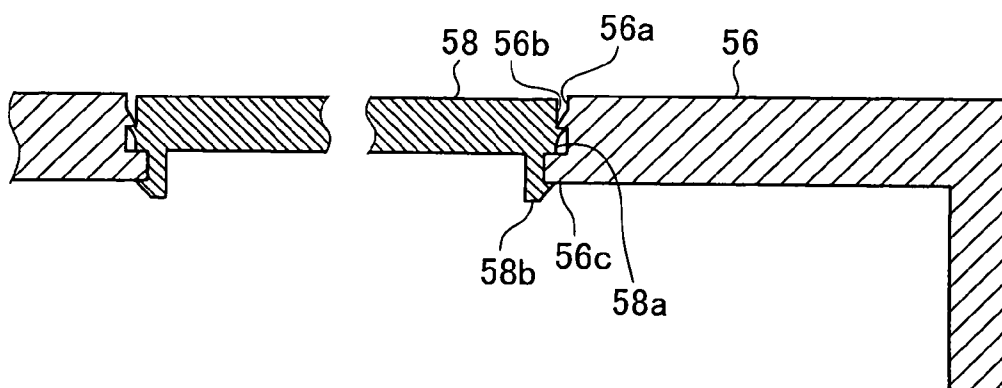

FIG. 8

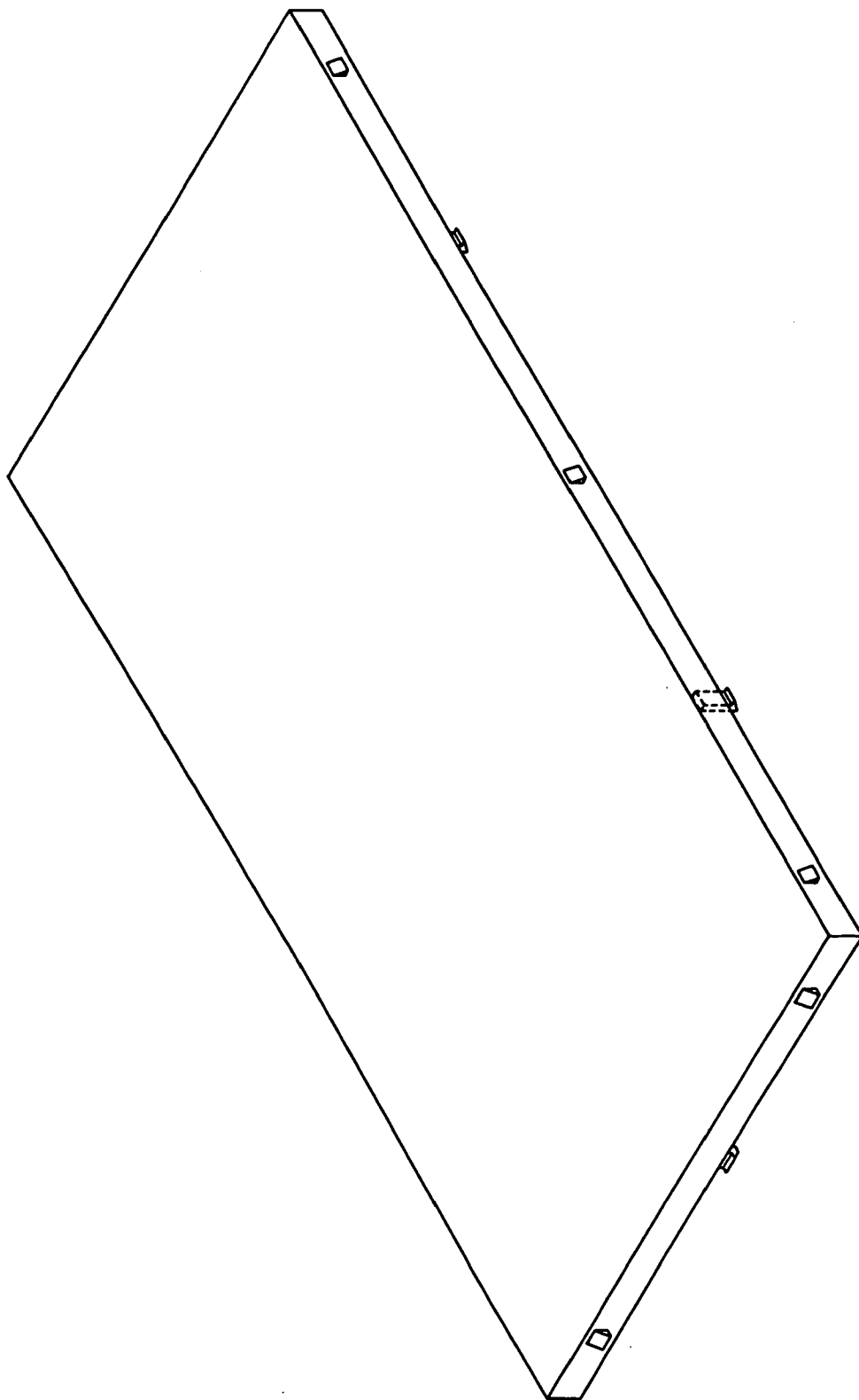

FIG. 9

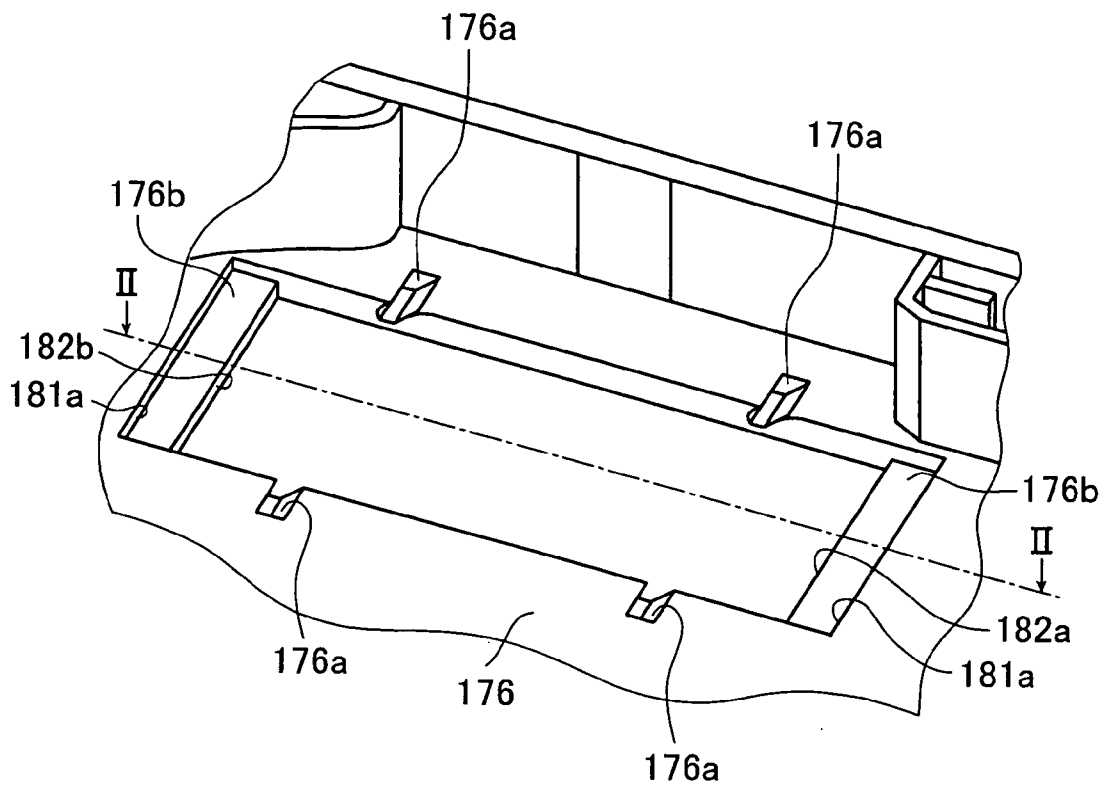

FIG. 10

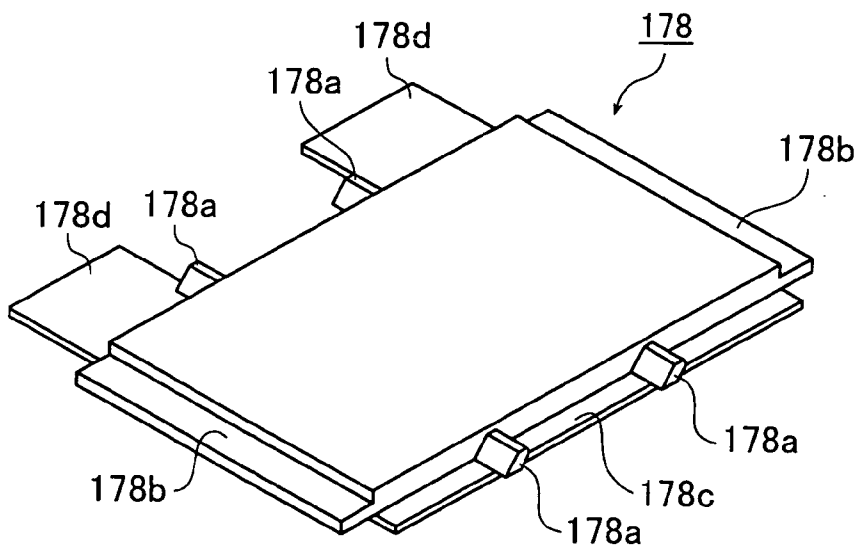

FIG. 11

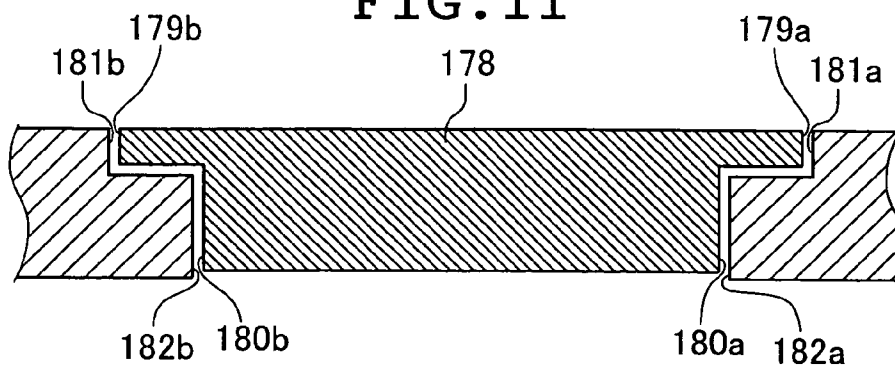

FIG. 12A

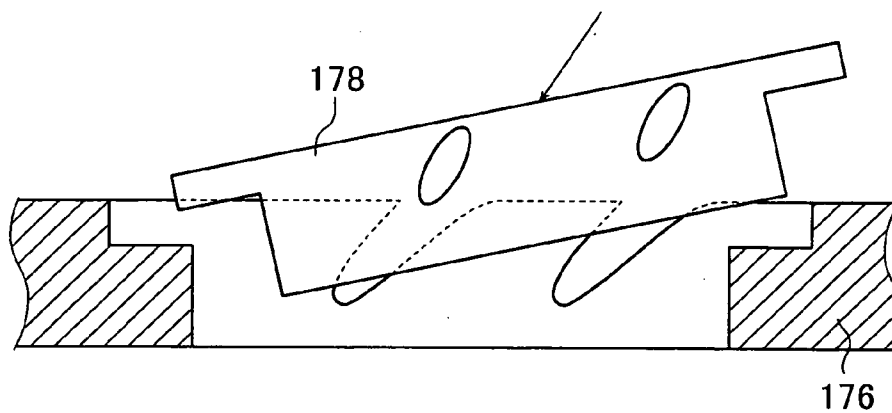

FIG. 12B

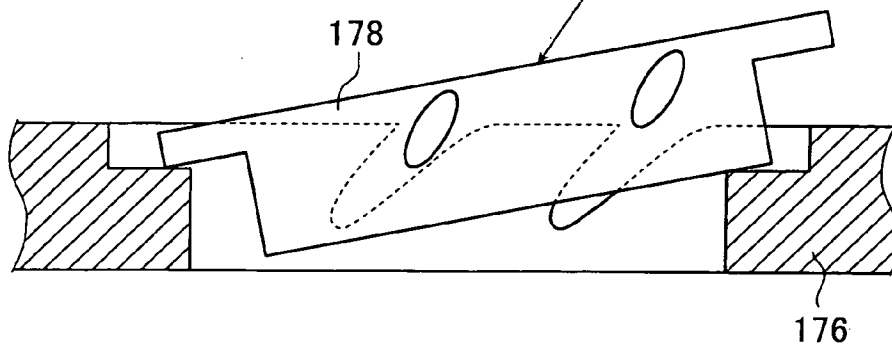

FIG. 12C

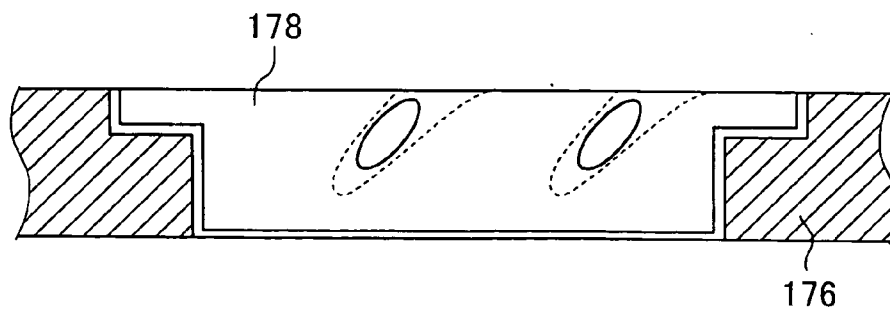

FIG. 13A

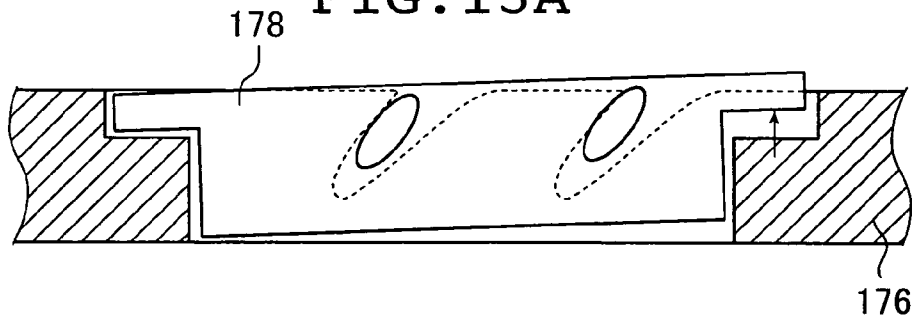

FIG. 13B

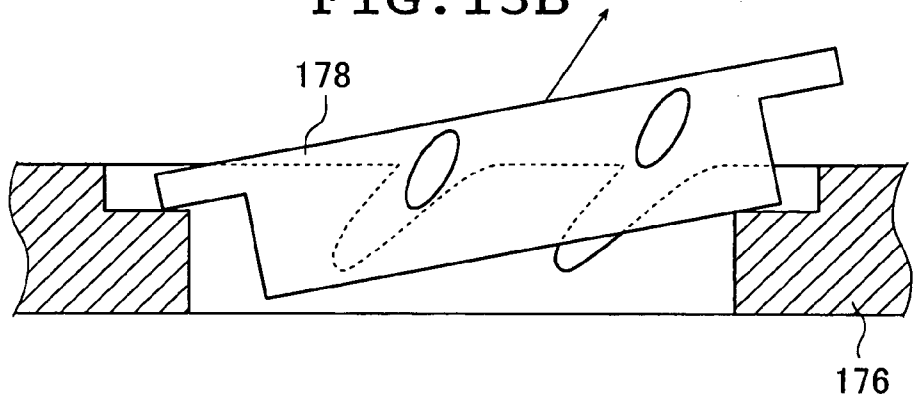

FIG. 13C

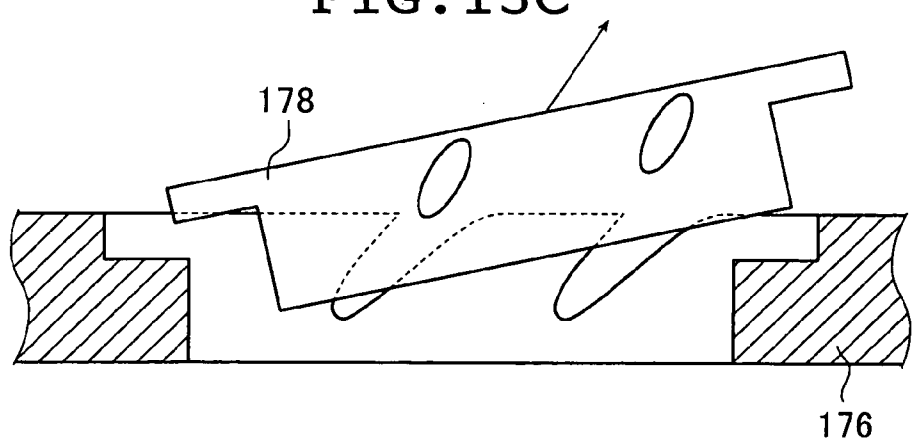

FIG. 14A



FIG. 14B



FIG. 14C



FIG. 14D



FIG. 15

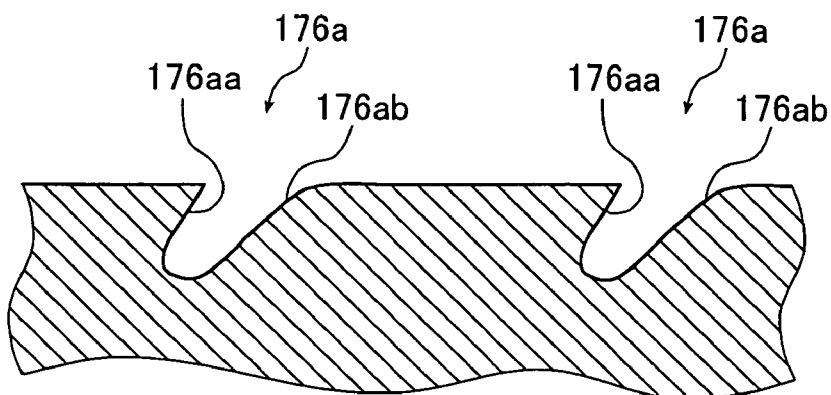

FIG. 16A

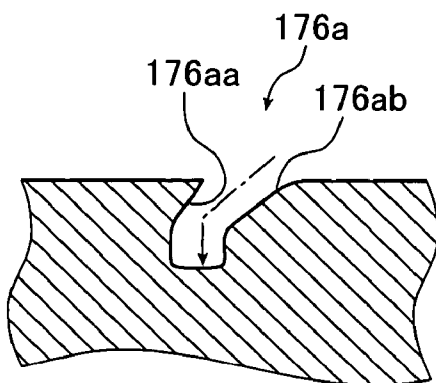

FIG. 16B

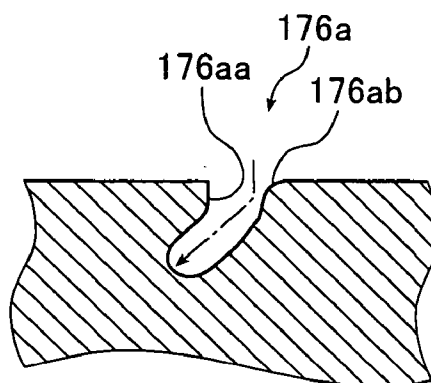

FIG. 17

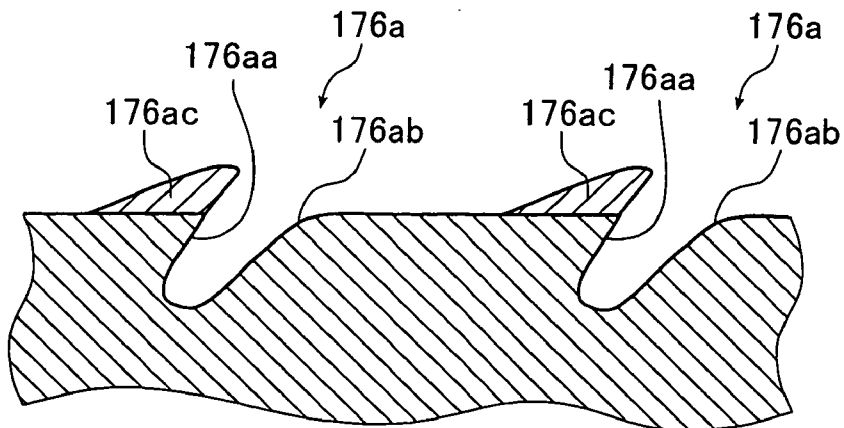

FIG. 18

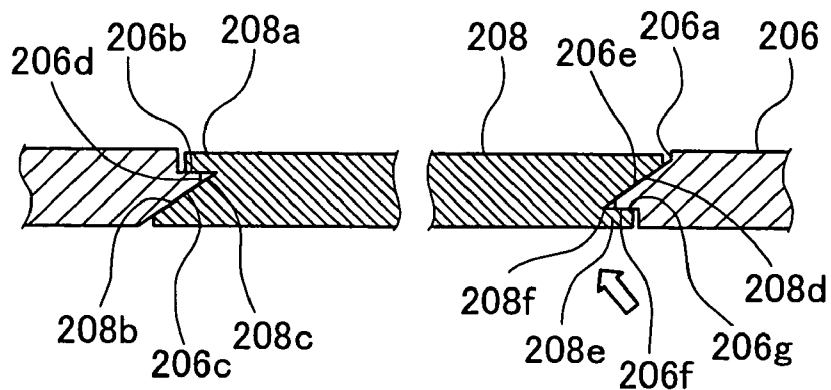

FIG. 19

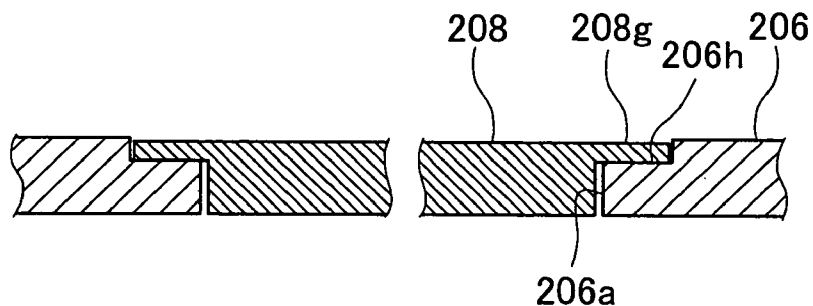

FIG. 20

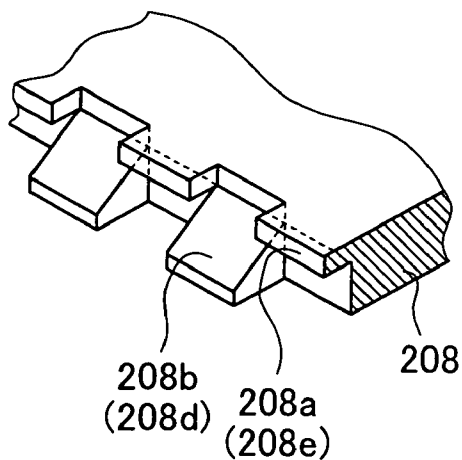

FIG. 21

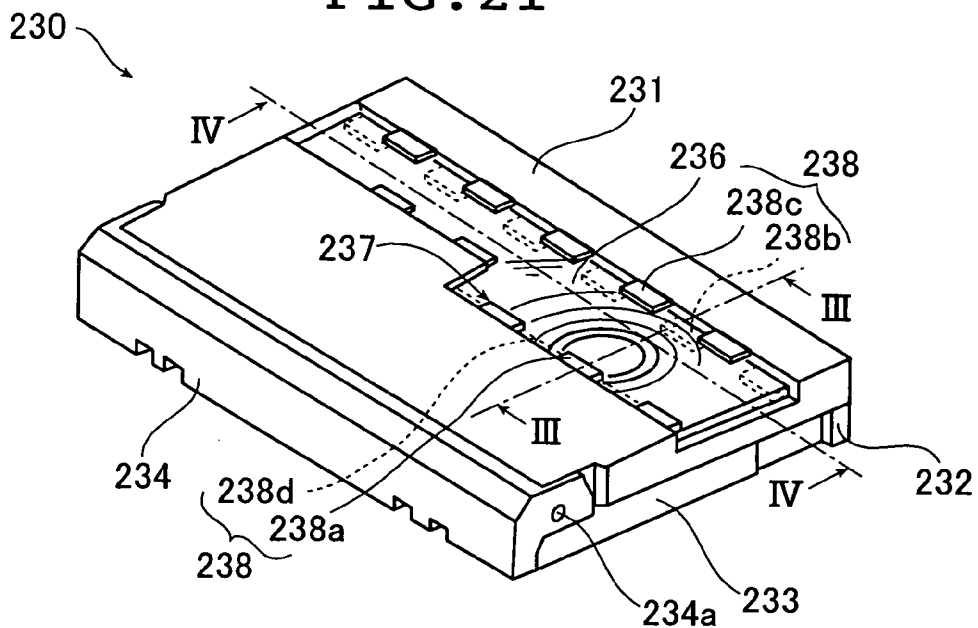

FIG. 22

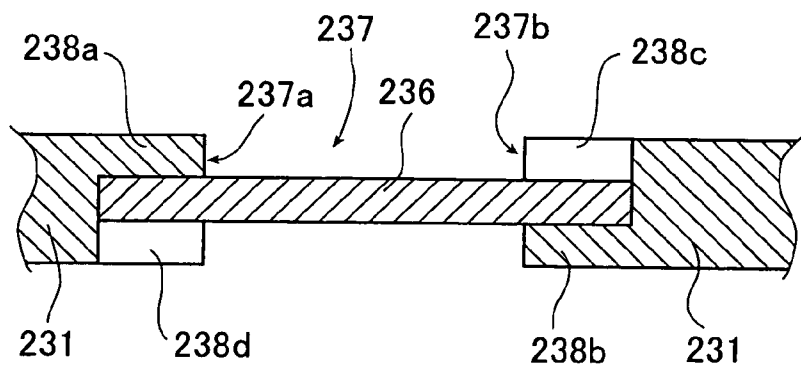

FIG. 23

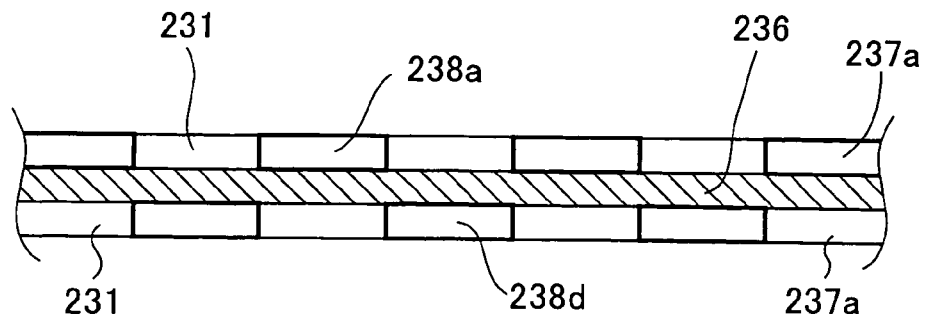

FIG. 24

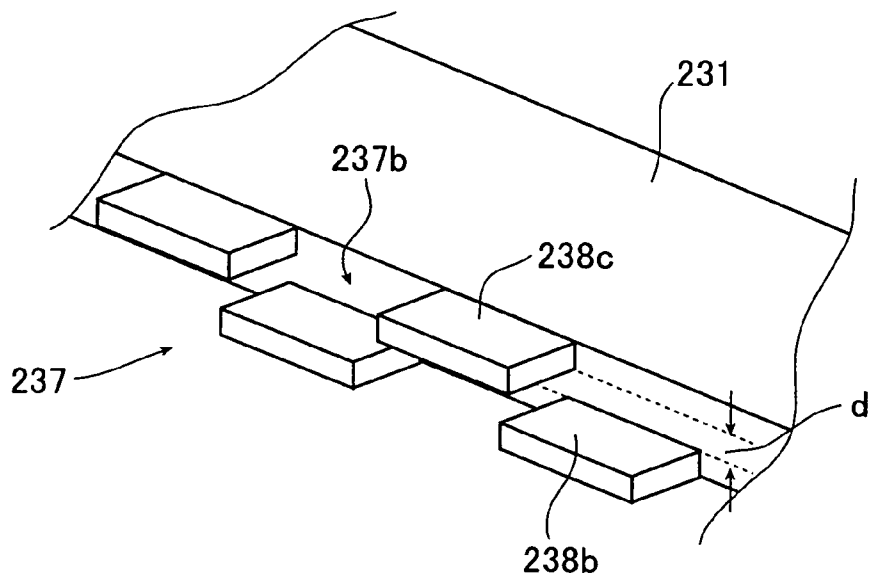

FIG. 25

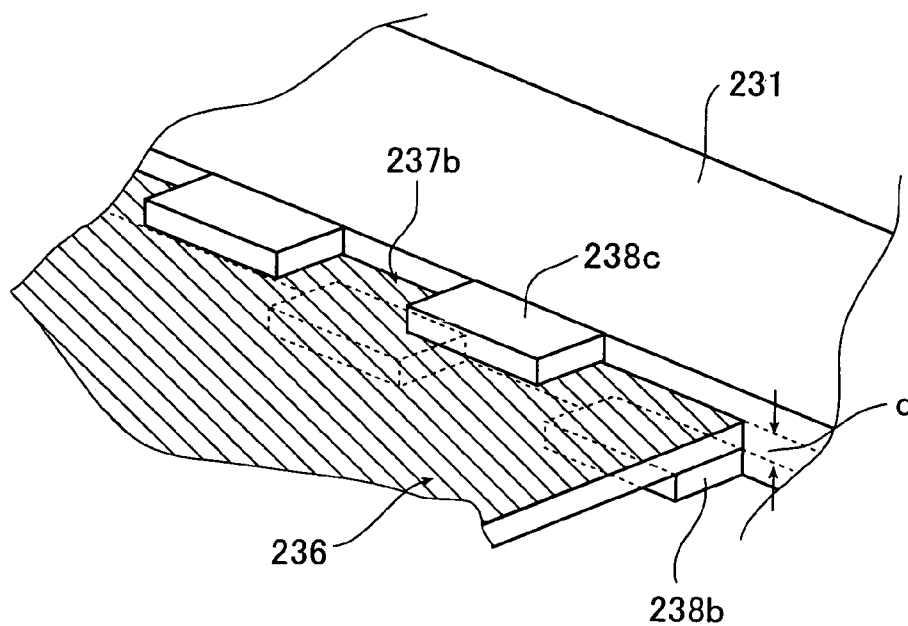

FIG. 26

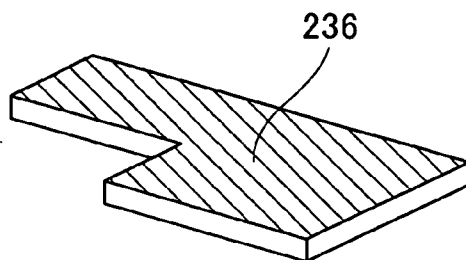

FIG. 27

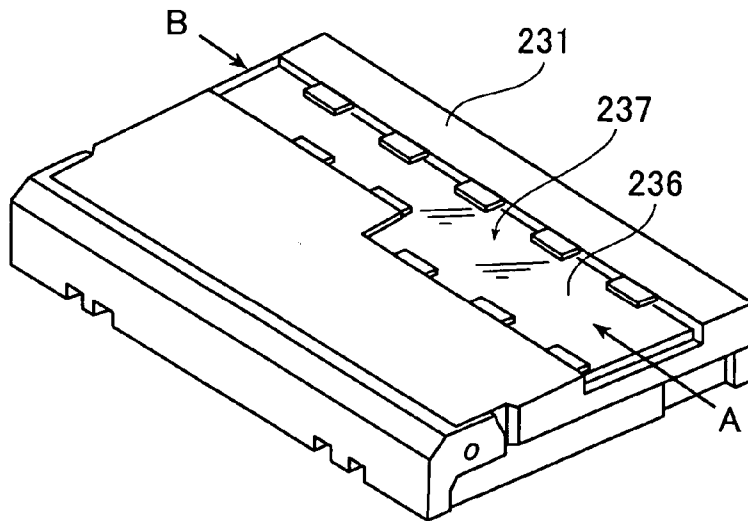

FIG. 28

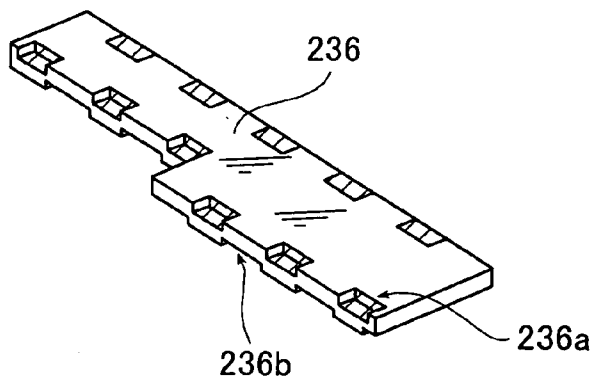

FIG. 29

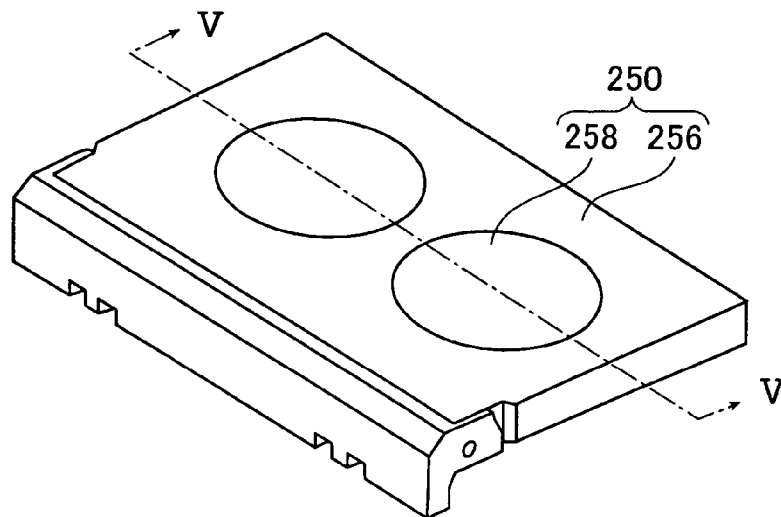

FIG. 30

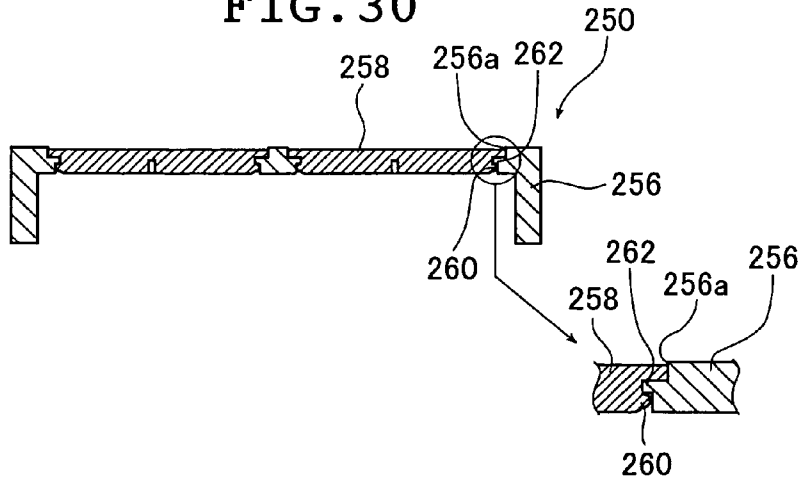

FIG. 31

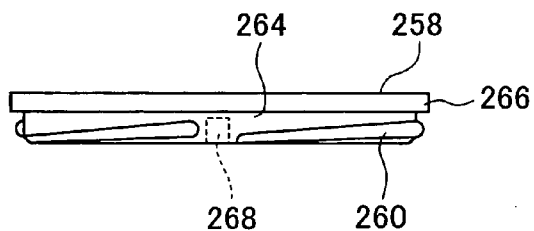

FIG. 32

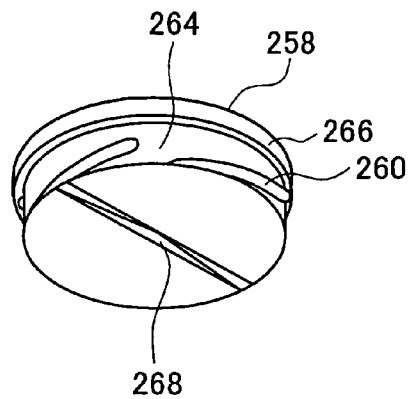

FIG. 33A

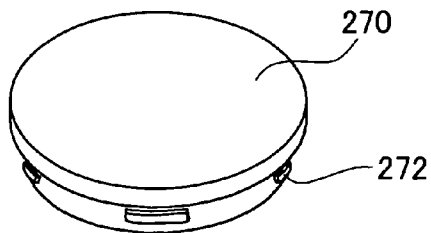

FIG. 33B

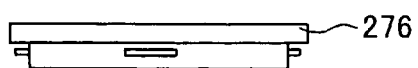

FIG. 34

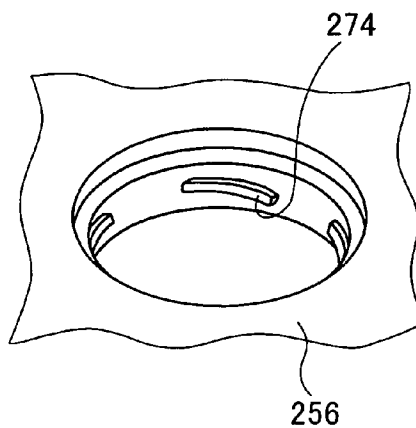

FIG. 35

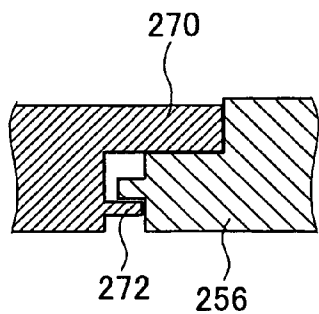

FIG. 36

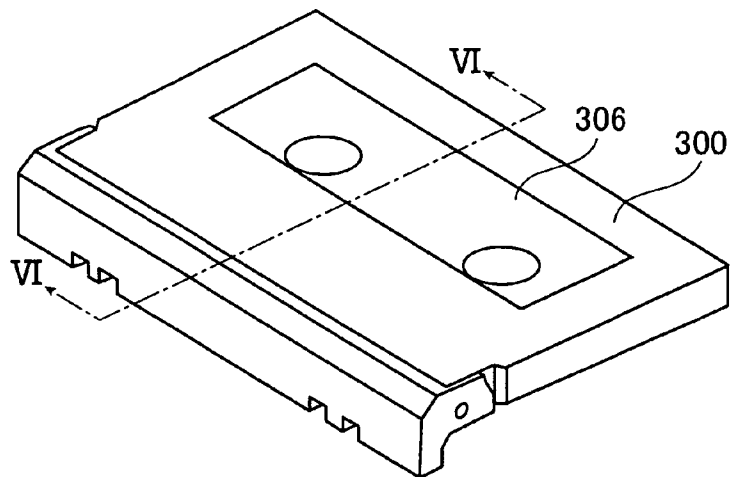

FIG. 37

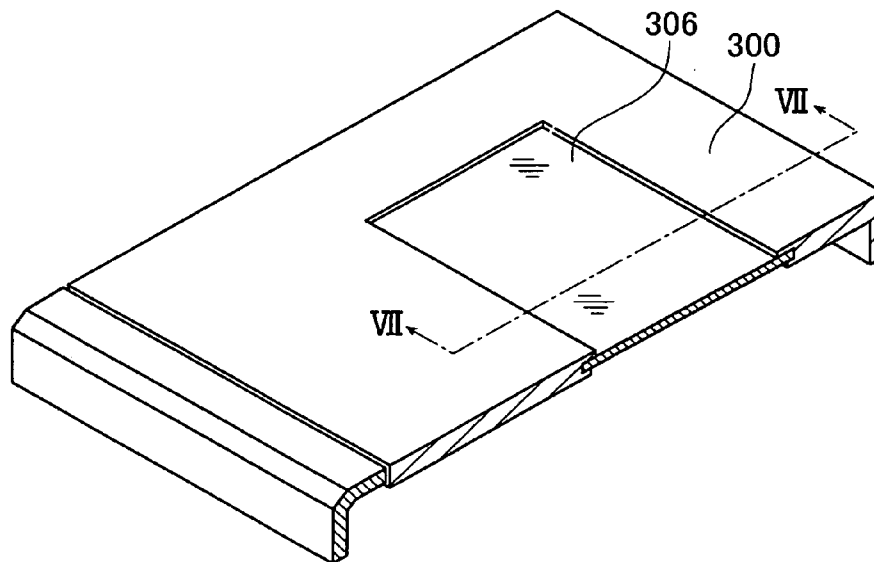

FIG. 38

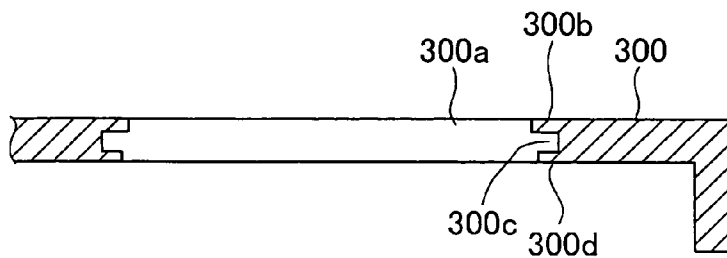

FIG. 39

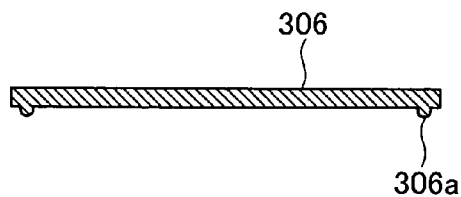

FIG. 40

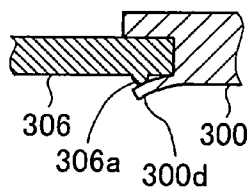

FIG. 41

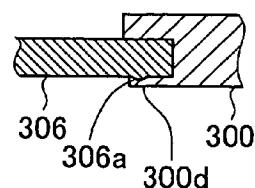

FIG. 42

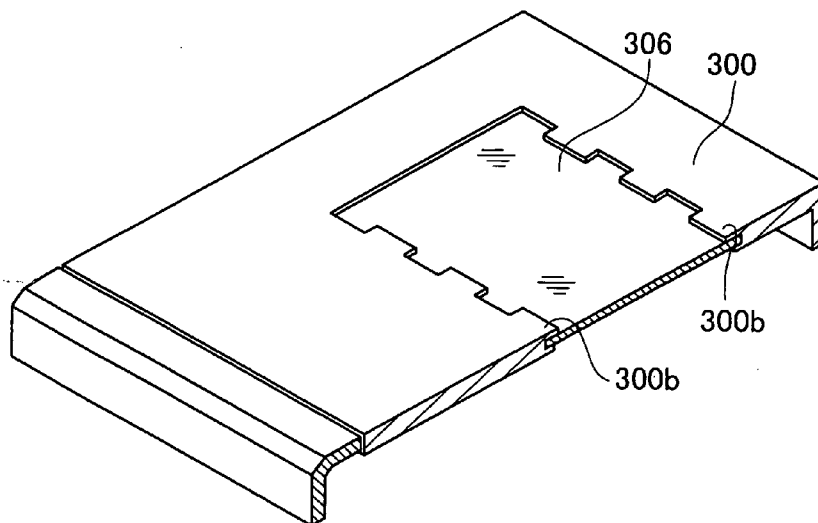

FIG. 43

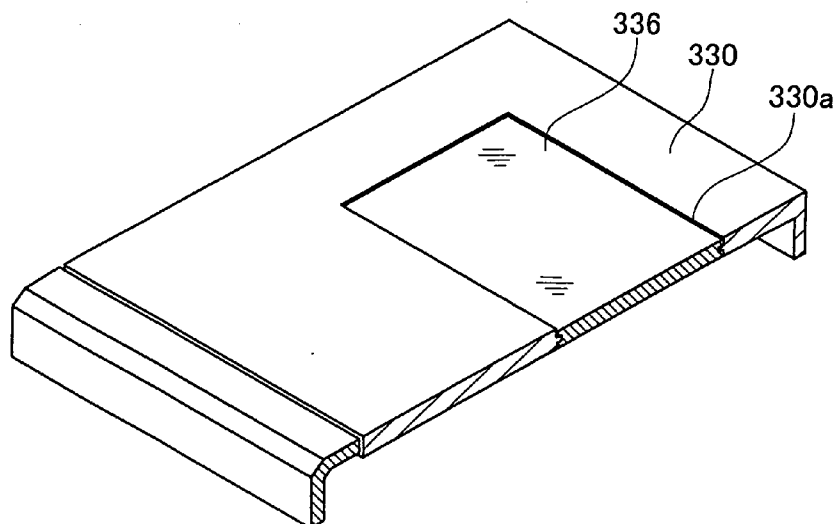

FIG. 44

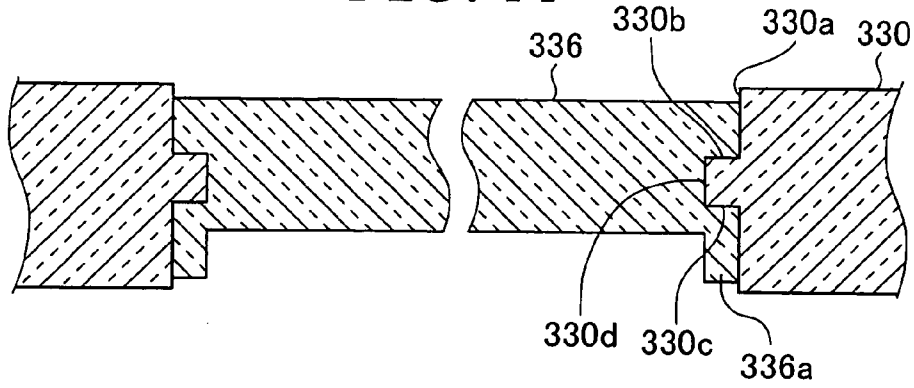

FIG. 45A

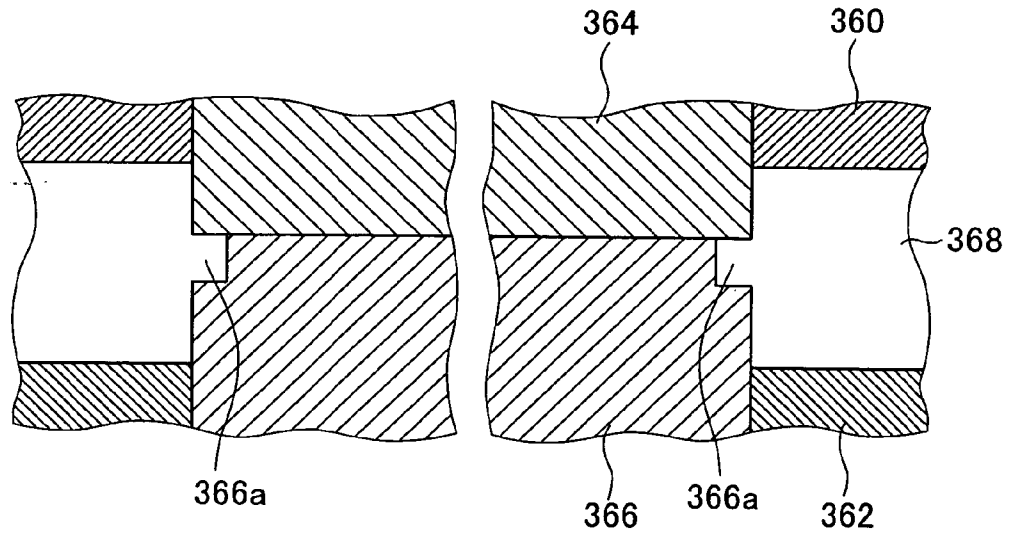

FIG. 45B

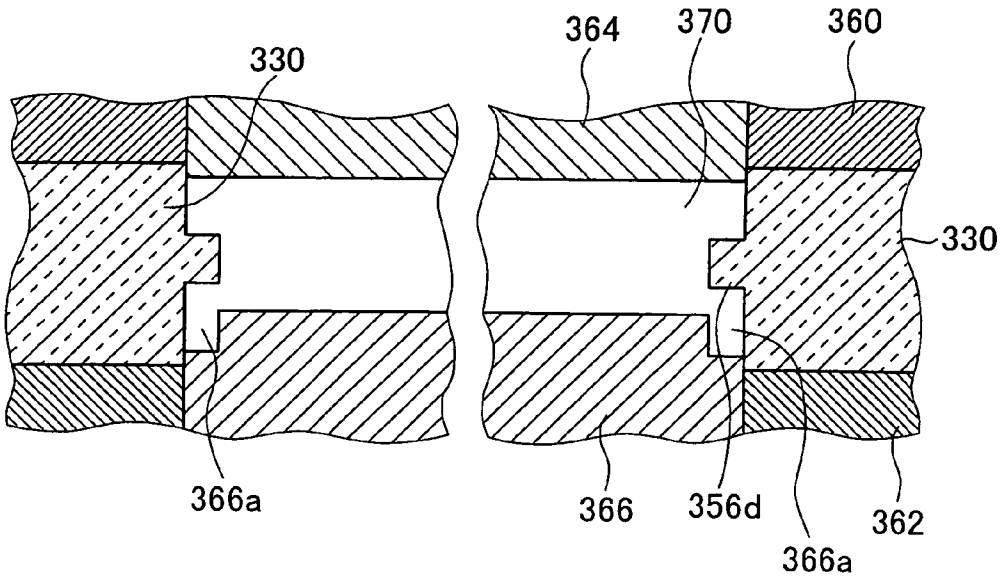

FIG. 46

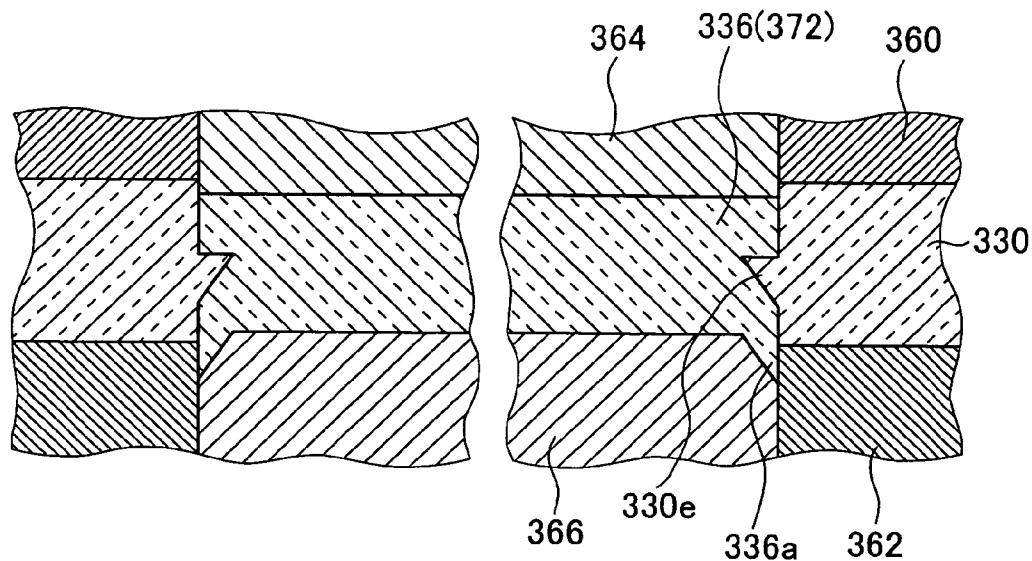

FIG. 47

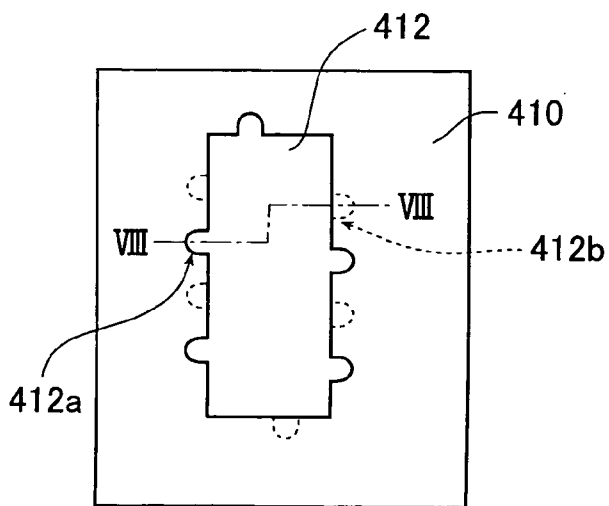

FIG. 48

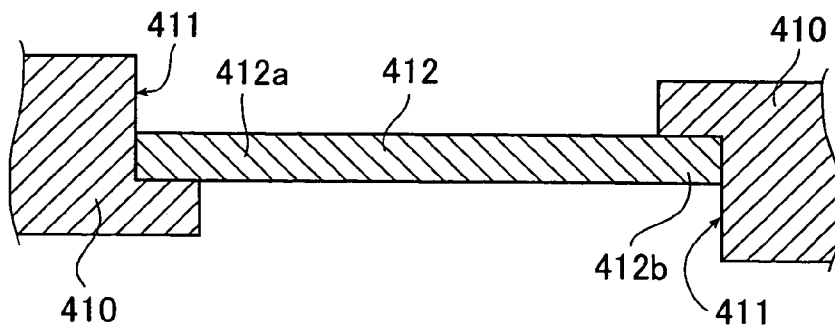

FIG. 49

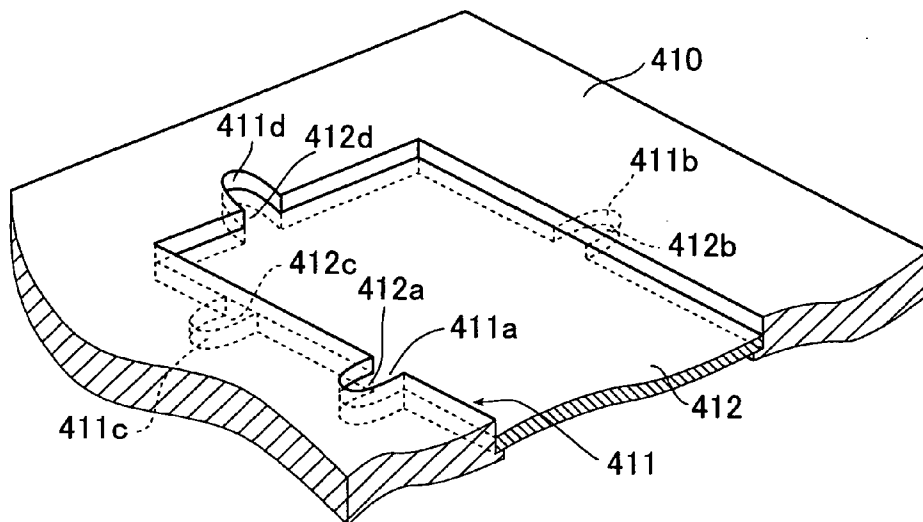

FIG. 50

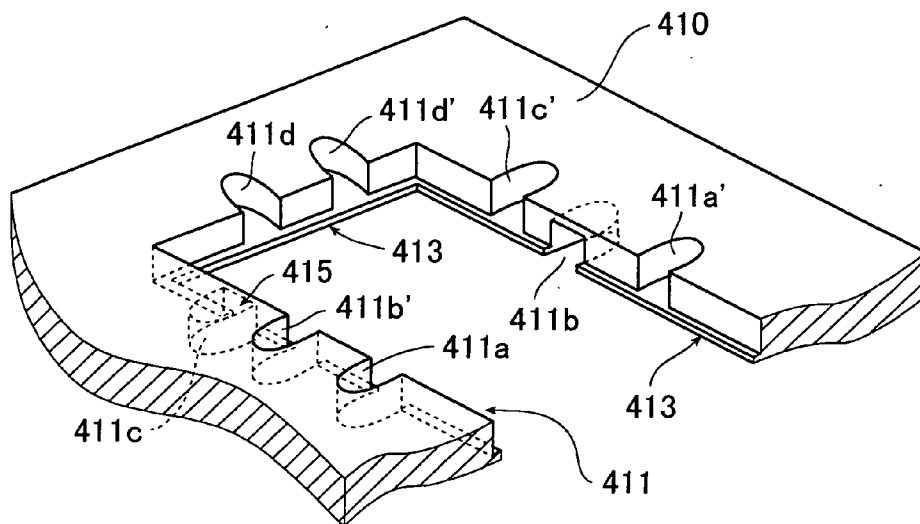

FIG. 51

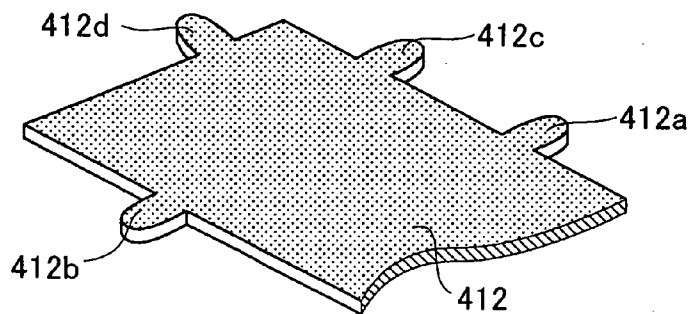

FIG. 52

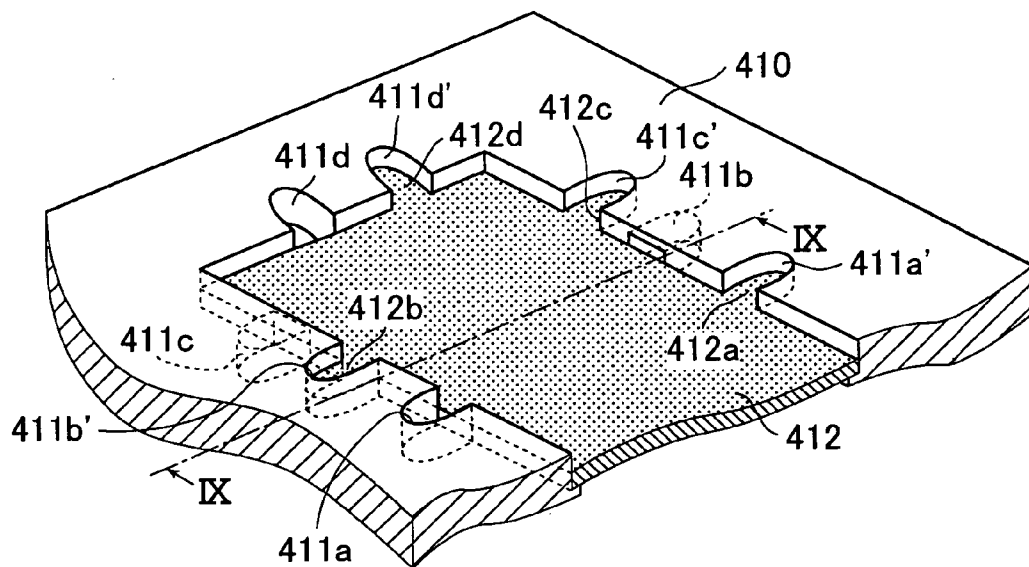

FIG. 54

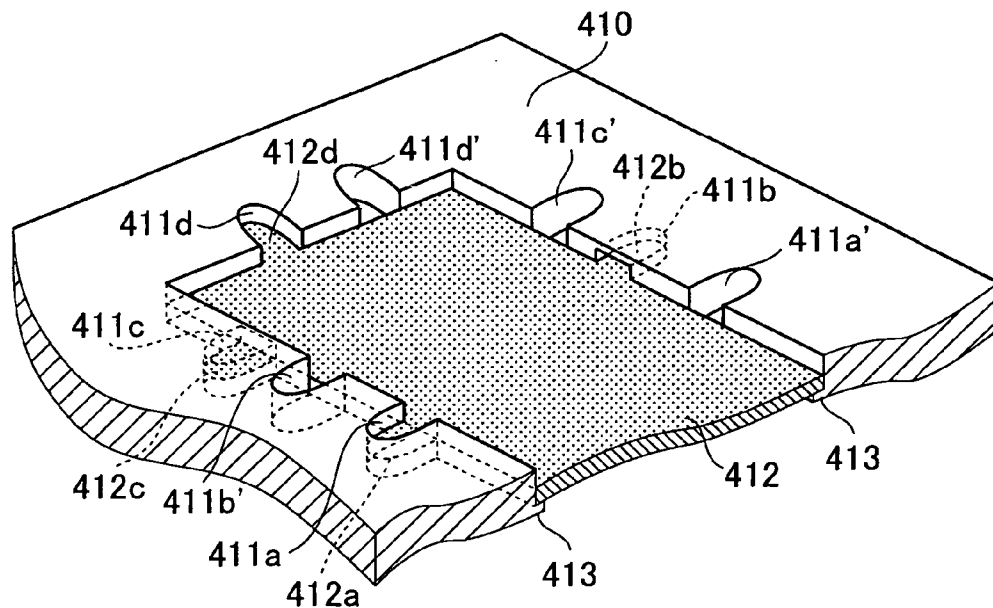

FIG. 53A

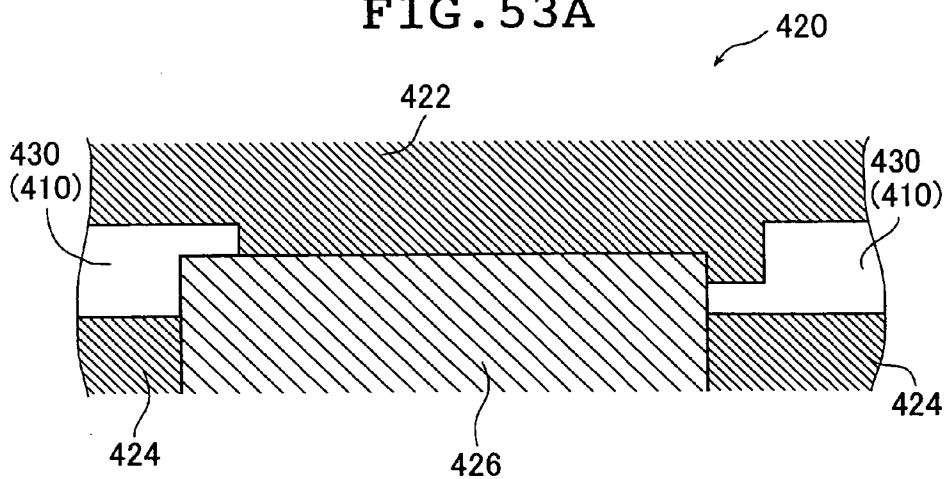

FIG. 53B

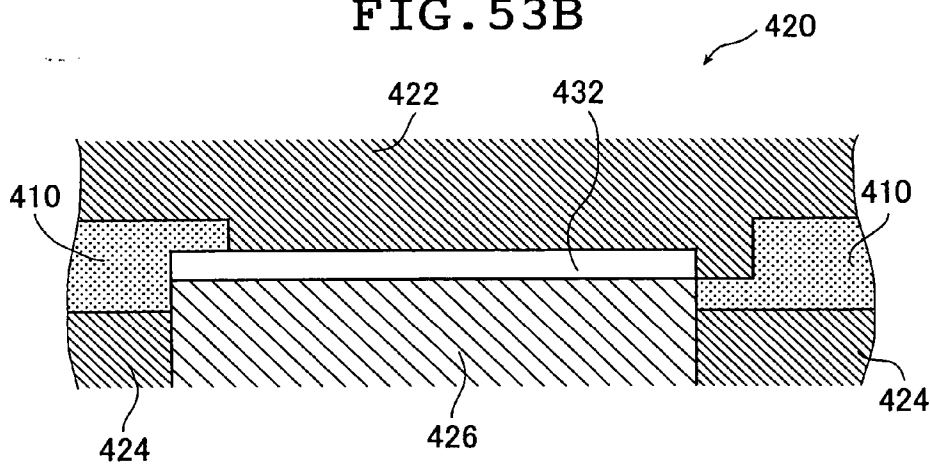

FIG. 53C

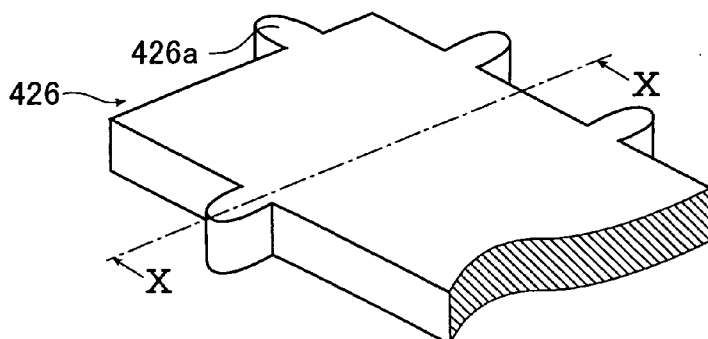

FIG. 55

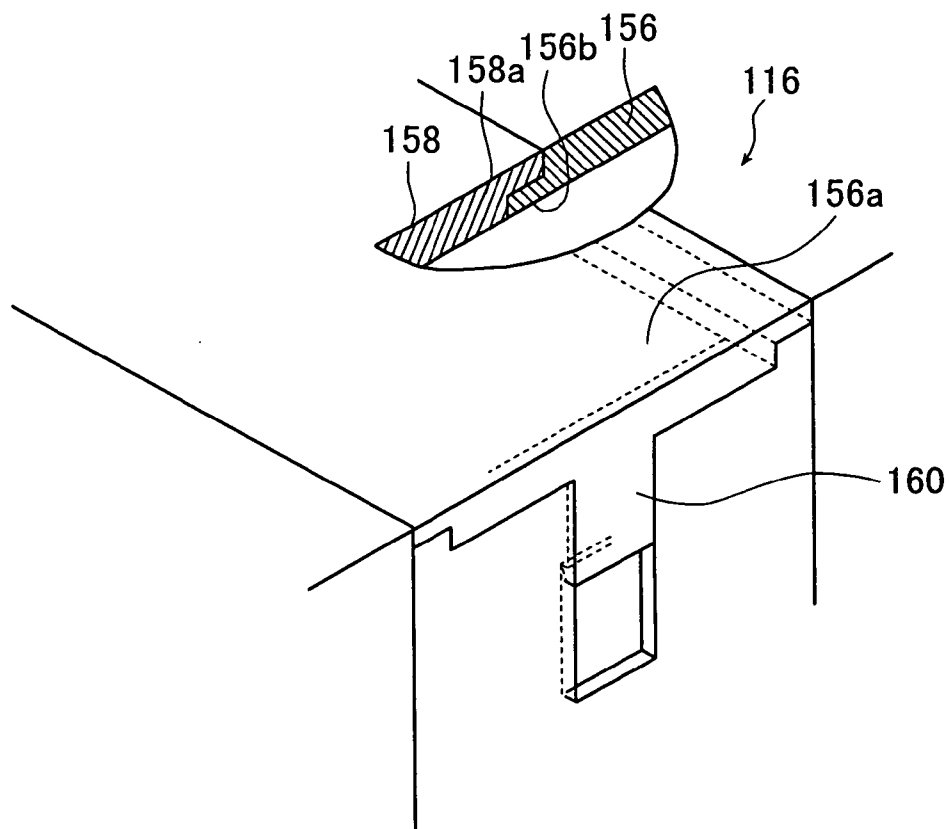

FIG. 56

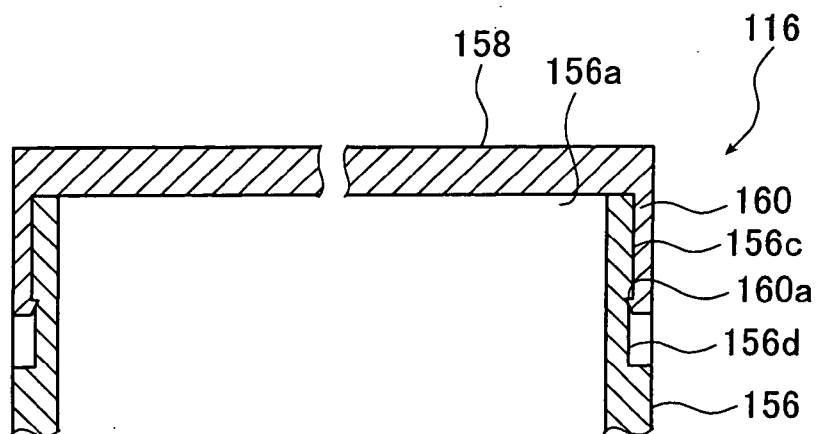

FIG. 57

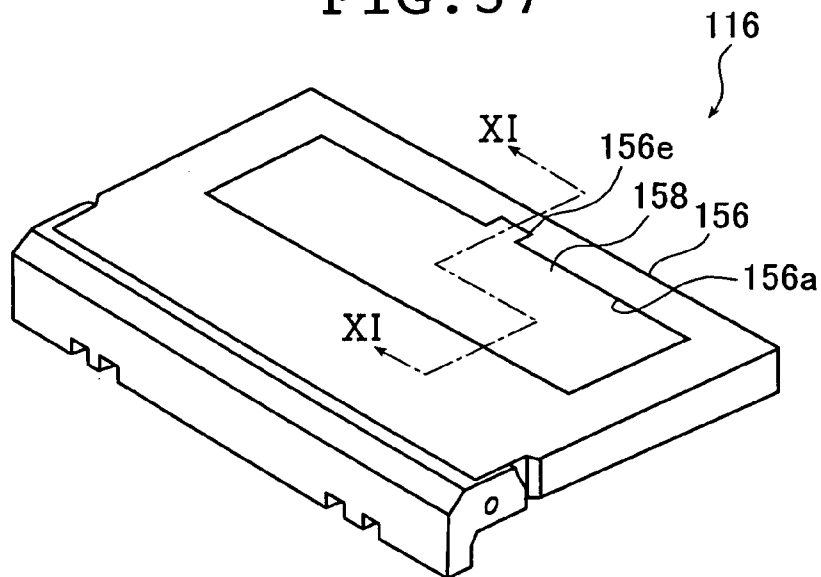

FIG. 58A

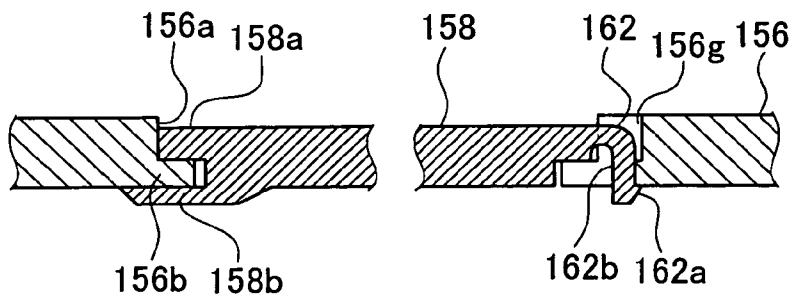

FIG. 58B

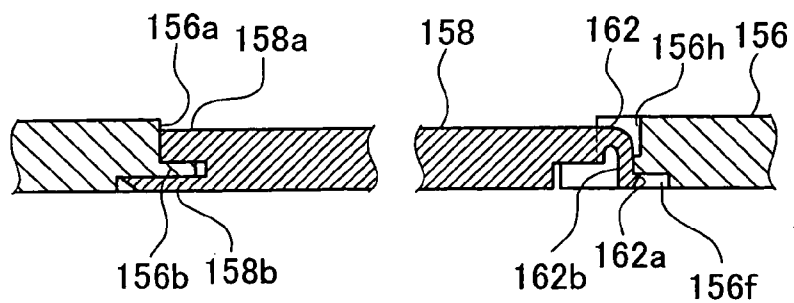

FIG. 59

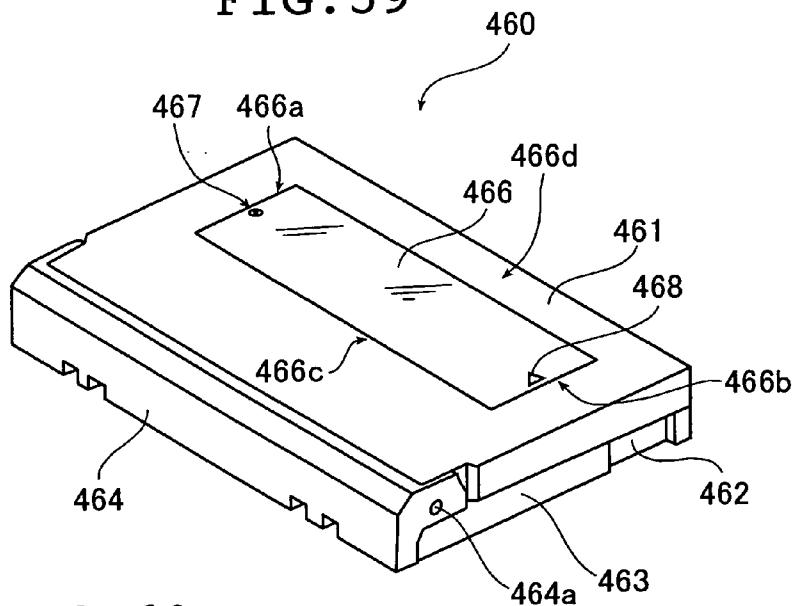

FIG. 60

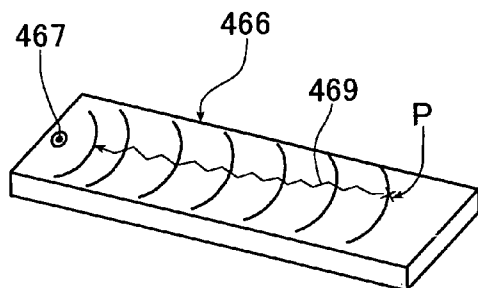

FIG. 61

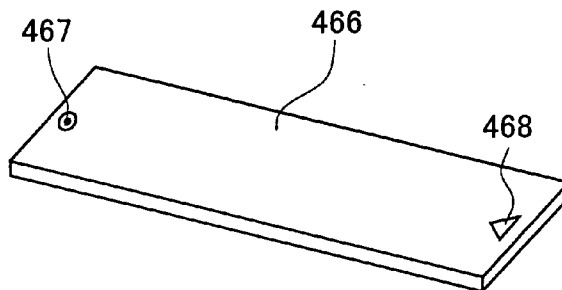

FIG. 62

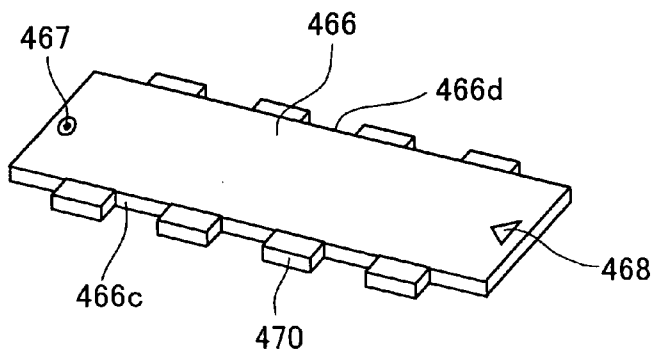

FIG. 63

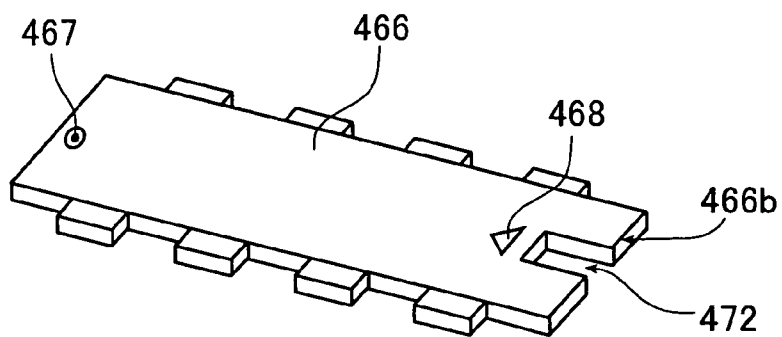

FIG. 64

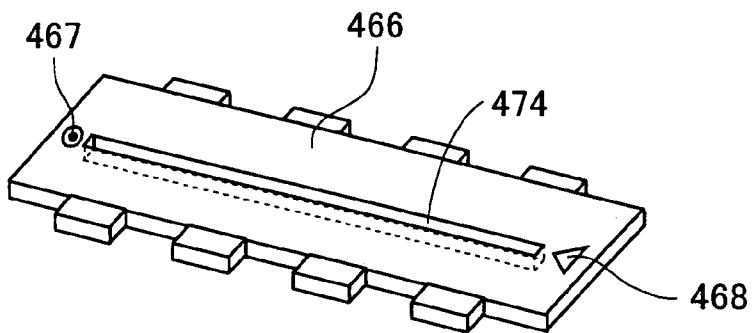

FIG. 65

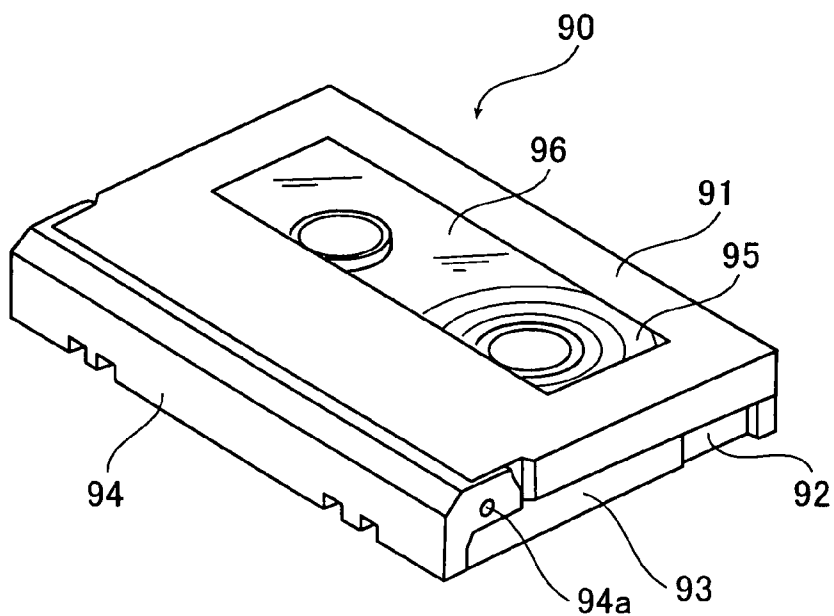

FIG. 66A

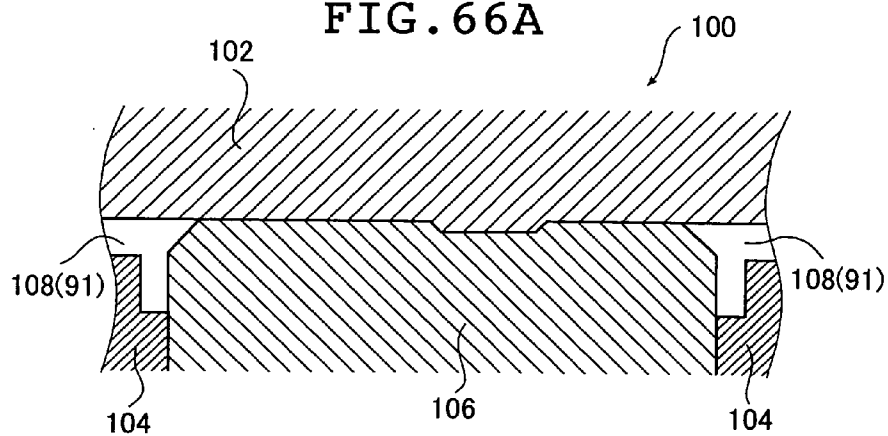

FIG. 66B

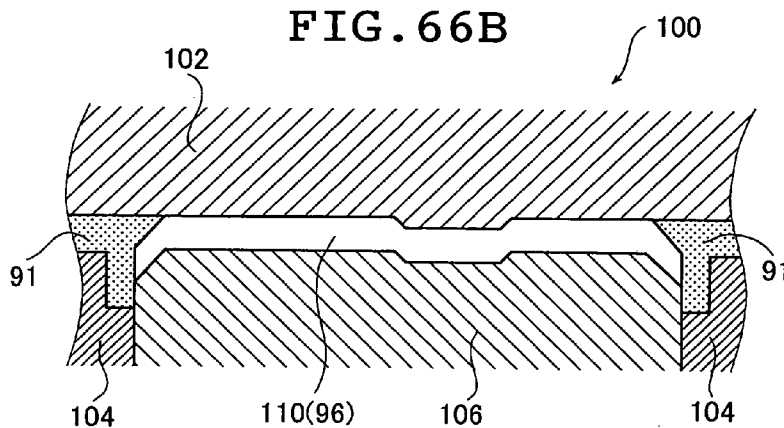

FIG. 67

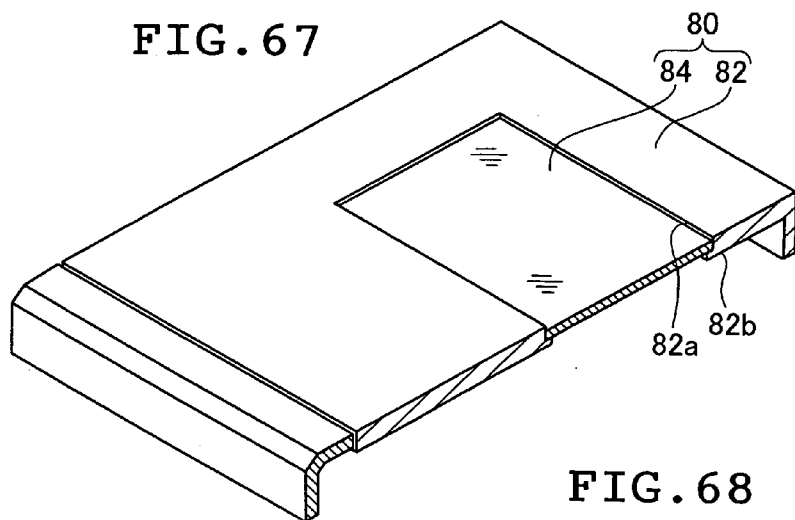
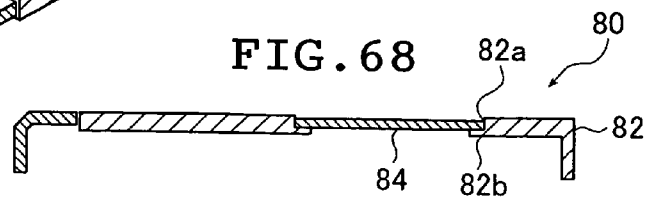

FIG. 68



MAGNETIC TAPE CASSETTES AND PROCESSES FOR PRODUCING THEM

[0001] This is a divisional of application Ser. No. 10/183,372 filed Jun. 28, 2002. The entire disclosure of the prior application Ser. No. 10/183,372 is considered part of the disclosure of the accompanying divisional application and is hereby incorporated by reference.

BACKGROUND OF THE INVENTION

[0002] This invention relates to magnetic tape cassettes having an easy-to-separate transparent window and processes for producing them. The invention particularly relates to magnetic tape cassettes that have a transparent window formed of a transparent resin (plastic) window member in the upper half of the cassette in such a way that when the cassette is discarded after use, the window member can be easily separated from the opening in the base (the body of the upper half) so that the base and the window member can individually be recovered as recyclable feeds as well as a process for producing the magnetic tape cassettes.

[0003] The invention also relates to shaped resin articles that are so designed that members of different materials can be easily separated from each other, as exemplified by magnetic tape cassettes which are so designed that the transparent window in the housing (cassette case) through which the user can check the residual amount of tape (visually) is easily separable from the housing (or its base).

[0004] The invention also relates to a method for multi-color molding of resin products, particularly of magnetic tape cassettes which are so designed that the transparent residual tape check window in the housing (cassette case) is easily separable from the housing.

[0005] The invention further relates to a method for destructing and separating parts made of dissimilar materials which is particularly applicable to the magnetic tape cassette and by which the transparent residual tape check window in the housing (cassette case) of the magnetic tape can be easily separated from the housing which is made of a dissimilar material than the transparent window.

[0006] As an introduction to the specific description of the invention, magnetic tape cassettes are well known which are of such a type that a web of magnetic tape is wound around a pair of take-up hubs which are rotatably housed in the housing (cassette case). This magnetic tape cassette has a transparent window formed in the upper half so that the user can see through it to check the residual amount of the magnetic tape wound around the right and left take-up hubs. Obviously, in order to eliminate the waste of resources and save them or protect the environment, it is most desirable that the upper half of the magnetic tape cassette, when discarded after use, should be disassembled into its body (base) and the transparent window member so that they can be recycled as new feeds.

[0007] Considering these points, the present invention provides easy-to-disassemble magnetic tape cassettes (or their upper half) and processes for producing them, shaped resin particles such as magnetic tape cassettes, a method for multi-color molding of resin products such as magnetic tape cassettes (or their upper half) and a method for destructing and separating parts of dissimilar materials such as the transparent window and the housing (cassette case) of magnetic tape cassettes.

[0008] With the recent concern over environmental problems, people are worrying about the adverse effects that may be caused to the environment by increased dumping of resins (plastics), composites and other materials. Under the circumstances, reducing the impact on the environment by either minimizing wastes or dumping them in forms that are not deleterious to the purpose of preserving the environment is becoming increasingly important. To this end, efforts are being made to integrate industrial products into the circulating system of the society at large by, for example, ensuring that they can be easily disassembled into various parts by materials type so that the latter can be recycled as much as possible.

[0009] Two types of magnetic tape cassette are known as image recording and reproducing tape cassettes that are used in consumer or professional video tape recorders or video cameras, and also as large-capacity recording media that are used to back up data in external storages in computers and the like; the first type comprises magnetic tape wound around a pair of take-up hubs placed rotatably in a cassette case consisting of an upper half and a lower half (which is hereunder referred to simply as a housing) and the second type comprises magnetic tape wound around a single tape reel also encased rotatably in a housing. Known examples are magnetic tape cassettes the structural and dimensional specifications of which are described in JIS X6127, X6129, X6130, X6171 and X6172, as well as in ECMA-288, etc. Those various types of magnetic tape cassette are designed as complex structures formed of various metallic members in combination with various synthetic resin members depending upon the performance and shapes required of the parts of which they are made.

[0010] The various types of magnetic tape cassette mentioned above have a window formed in one or more openings in the top plate of the upper half and in order to ensure that the user can externally check the amount, state and other parameters of the magnetic tape that has been taken up by the hubs or the tape reel in the cassette case, the window is formed by fitting a transparent or translucent window member in the opening or openings. The windows are made of various resin materials depending upon the impact strength, wear resistance, durability and other characteristics required of the respective magnetic tape cassettes. For example, window members formed of an AS resin may be fitted in cassette cases formed of an ABS resin; alternatively, all parts including the cassette case and the window member may be formed of a PS resin. Thus, magnetic tape cassettes are made of various resins depending upon the required performance and shapes and are not formed of unified materials.

[0011] A common magnetic tape cassette may diagrammatically be shown in perspective in FIG. 65. As shown, the magnetic tape cassette generally indicated by 90 consists of an upper half 91 and a lower half 92 that combine to form the cassette case as the housing. A slider 93 is fitted to the underside of the lower half 92 and a lid 94 is provided at the front face of the cassette (which is closer to the viewer). The slider 93 can slide back and forth on the underside of the lower half 92 so that when the cassette is not in service, the slider prevents dust from getting into the cassette by closing the opening in the lower part of the cassette case. The lid 94 on the upper half 91 is pivotally mounted on a shaft 94a so that it can open or close the front face of the cassette.

[0012] The housing of the magnetic tape cassette **90** contains magnetic tape **95** as it is wound around a pair of take-up hubs. The upper half **91** has a transparent window **96** through which the residual amount of tape in the magnetic tape cassette **90** can be checked as when it has been taken out of the deck (not shown).

[0013] As already mentioned, the respective parts of the magnetic tape cassette are formed of synthetic resins. Specifically, members that require sliding properties (wear resistance) are molded of POM (polyacetal) resin; if cost performance is important, Si (silicon) is added to PS (polystyrene) to prepare a resin molding material; if strength is an important factor, ABS (acrylonitrile-butadiene-styrene) resin is employed.

[0014] Speaking of video cassettes which are generally molded of ABS, the transparent residual tape check window is often molded of ABS-compatible resins such as AS (acrylonitrile-styrene) and PMMA [poly(methyl methacrylate)]. This is because the window and the cassette case are formed by two-color molding (two-layer molding) and subsequently bonded by welding.

[0015] The molding of the magnetic tape cassette under consideration, especially the molding of the upper half **91** and the window **96** is conventionally performed as follows.

[0016] As shown in **FIG. 66A**, a die assembly **100** for molding the upper half **91** and the window member **96** is basically composed of an upper die **102**, a lower die **104** and a moving (sliding) core **106**. The upper die **102**, the lower die **104** and the moving core **106** define a space **108**, into which a molten resin [e.g. ABS (acrylonitrile-butadiene-styrene) resin] is injected to mold the upper half **91**. Then, as shown in **FIG. 66B**, the moving core **106** is allowed to descend by a distance equal to the thickness of the window member **96**; into the resulting space **110**, a transparent resin [e.g. AS (acrylonitrile-styrene) resin] is injected to mold the window member **96**.

[0017] Conventionally, as shown in **FIGS. 66A and 66B**, the edges of the moving core **106** are cut out at an angle (beveled) so that the area of contact between the window **96** and the upper half **91** is sufficiently increased to achieve more effective bonding of the two components after molding.

[0018] **FIG. 67** shows in perspective the upper half of the cassette case of the prior art magnetic tape cassette with part taken away after it has been cut through the transparent window, and **FIG. 68** is a section of **FIG. 67** which has been taken through the transparent window. In order to fabricate the upper half **80** of the conventional cassette case, the body **82** serving as the base is first provided; then an opening **82a** is made in the body **82** to provide an area in which a transparent window member **84** can later be fitted and a window frame **82b** is formed around the opening **82a** to support the window member **84**; subsequently, the window member **84** is fitted into the opening **82a** in the body **82** and welded to the supporting window frame **82b** by ultrasonic welding or some other method.

[0019] The method of transparent window fabrication which is illustrated by **FIGS. 67 and 68** is convenient and suitable for mass production of cassette cases. However, if the upper half **80** of the cassette case discarded after use is to be disassembled into its body **82** and the window member

84 so that they can be recycled as new feeds, a serious problem arises, i.e., since the transparent window **84** is welded to the body **82**, it is very difficult to disassemble the upper half **80** without breaking either the body **82** or the window member **84**.

[0020] Even if the upper half **80** is disassembled by breaking either its body **82** or the window member **84**, it is practically impossible to ensure that both are positively separated from the welded area and part of the window member **84** will remain firmly adherent to the upper half's body **82** or vice versa. Under these circumstances, if an attempt is made to recycle the upper half's body **82** and the window member **84** as respectively new feeds, the two components inevitably occur as a mixture—part of the window member **84** firmly adheres to the upper half's body **82** and part of the body **82** firmly adheres to the window member **84** and it has been unavoidable that the recycled feeds have only low purity.

[0021] The transparent window as a component of the cassette case is included as part of the upper half **80** and must impart air-tightness for dust prevention and other purposes. In addition, the cassette case involves manual handling at various stages of its use including carrying, storage and loading onto the recording and reproducing apparatus and it must have sufficient strength that it will not break or become dislodged during handling.

[0022] As already mentioned, the conventional magnetic tape cassette molded by the method illustrated in **FIGS. 66A and 66B** features a very strong bond between the transparent window and the housing in order to maintain the strength of the cassette case and considerable force is usually required to separate the window from the housing by hand. Because of this strong bond, it has been difficult to achieve selective recovery of dissimilar materials, particularly ABS from AS or PMMA. The high peel strength of the conventional magnetic tape cassette is desirable from the viewpoint of ensuring that it performs the intended functions; however, its shape does not allow easy disassembling into the window and the housing.

[0023] Furthermore, if the user attempts to separate the window from the housing by force, he has to break the window but if it does not break easily and neat, he may be hurt by the shattered pieces of window. Simply cutting slits or otherwise rendering the window easily breakable is not capable of producing a sufficiently dust-proof cassette case. The window once bonded firmly to the upper half does not break easily and if it is destroyed by force, it will partly remain adhering to the housing; this is better than what has been attained in the prior art but the separation is by no means complete. If the window is not collected as a separate entity from the housing or if the separation is not complete, the mixing of dissimilar materials makes it difficult to recycle the respective parts and regenerate materials of good quality (this type of recycling is called "materials recycling") that sell at competitive price. A need therefore arises to increase the precision in the separation technology.

[0024] Thus, it has been desired to design a magnetic tape cassette that permits easy separation of the window from the housing without compromising the dust-proofness of the cassette case. Common resin products have a similar need and they should desirably be so designed that various parts can be easily collected as separate entities, thereby making more parts recyclable.

[0025] As already mentioned, there is an increasing demand for designing industrial products that can be manufactured by making effective use of limited resources of the Earth and which can be disposed of in an environment friendly manner. This is one of the reasons why the components or constituent materials of magnetic tape cassettes that find massive use in a wide range of applications are desirably recycled to realize saving of resources and disposed of without increasing the impact on the environment.

[0026] Resins of which the magnetic tape cassettes are made can generally be recycled either as members, parts or resin feeds (materials recycling) or as fuels (thermal recycling).

[0027] Materials recycling presents no big problems in saving resources and reducing the environmental impact. On the other hand, thermal recycling involves the use of thermal energy and is not effective for preventing global warming since an increasing amount of heat is dissipated to the environment in the recycling process. Therefore, the magnetic tape cassettes are desirably made of members, parts or materials none or only a few of which need be subjected to thermal recycling.

[0028] From these viewpoints, the window member to be fitted in the upper half of the magnetic tape cassette should desirably satisfy the requirements of the saving resources, conserving the Earth's environment and not contributing to global warming.

[0029] The present invention has been accomplished under these circumstances and its primary objective is to solve the aforementioned problems of the prior art by providing a magnetic tape cassette which, in the case of disassembling a discarded magnetic cassette into the base (the body of the upper half) and the window member and recycling the respective parts as feeds for the manufacture of additional products, can be disassembled in an easy and safest way, preferably easily without breaking, and in an efficient way and which is also characterized in that no part of the window member will remain adhering to the base or vice versa, that the separated base or window member can be recycled as a feed for additional products without suffering a drop in purity, and that it has a transparent window which is sufficiently air-tight and strong to provide it with adequate air-tightness and strength. The invention also aims at providing a process for producing the magnetic tape cassette.

[0030] Another object of the invention is to provide a magnetic tape cassette of such a structure that, in the case of disassembling a discarded magnetic tape cassette into the upper half's body and the window member, utmost safety is assured in the disassembling operation, as well as a process for producing the magnetic tape cassette.

[0031] The second objective of the present invention is to provide a method for multi-color molding of resin products such as magnetic tape cassettes which can solve the aforementioned problems of the prior art by permitting easy separation and recovery of various parts of magnetic tape cassettes and other resin products so that they can be put to second use.

[0032] The third objective of the present invention is to provide shaped resin articles which can solve the aforementioned problems of the prior art by permitting easy separa-

tion and recovery of various parts of magnetic tape cassettes and other resin products so that they can be put to second use.

[0033] The fourth objective of the present invention is to provide a magnetic tape cassette which is effective for conserving the Earth's environment and preventing global warming by permitting less heat to be given off during recycling, thereby solving the aforementioned problems of the prior art.

[0034] Another object of the invention is to provide a magnetic tape cassette which, even in a less likely case where part of a discarded magnetic tape cassette is subjected to thermal recycling, can be processed emitting a smaller amount of heat during the recycling process.

[0035] The fifth objective of the present invention is to provide a method for breaking and separating dissimilar materials which solves the aforementioned problems of the prior art by permitting easy separation and recovery of various parts of shaped articles made of dissimilar materials, as in the case of magnetic tape cassettes and other resin products, so that they can be put to second use.

[0036] These objects and objectives of the present invention will become apparent as the following description evolves.

[0037] In order to attain the primary objective described above, according to a first aspect of the invention, there is provided a magnetic tape cassette having:

[0038] a base with an opening for forming a transparent window; and

[0039] a transparent resin-made window member to be installed in the opening, wherein

[0040] the window member is provided with engaging means which is to be fitted into the base at an angle and the base is provided with an engaging portion that is formed at an angle in correspondence to the engaging means, and wherein

[0041] the window member is installed in the opening by being fitted in at an angle.

[0042] The window member has preferably a step on perimeter or in end portions in order to prevent dust.

[0043] Further, depth of the engaging portion of the base is preferably greater than height of the engaging means provided on the window member.

[0044] In order to attain the primary objective described above, according to a second aspect of the invention, there is provided a magnetic tape cassette having:

[0045] a base with an opening for forming a transparent window; and

[0046] a window member to be installed in the opening, wherein

[0047] the base has in at least a part of an inner circumferential area of the opening an adequately rigid upper window frame, an elastically deformable lower window frame and a temporary fitting portion that allows the window member to be inserted between the upper and lower window frames,

[0048] the window member being made of a transparent resin that has no compatibility or has only low compatibility with a material of which the base is made, and

[0049] the upper window frame or the lower window frame around the opening or the window member is provided with a projection in a position where they contact each other, and wherein

[0050] the window member being inserted into the temporary fitting portion so that the lower window frame deforms elastically to achieve temporary joint between the window member and the base, and

[0051] ultrasonic waves or heat is allowed to act on the temporary joint.

[0052] According to the second aspect of the invention, there is also provided a process for producing a magnetic tape cassette having a base with an opening for forming a transparent window and a window member to be installed in the opening, comprising the steps of:

[0053] molding the window member of a material having no compatibility or having an extremely low degree of compatibility with the material of which the base is made;

[0054] molding the base in such a way that the base has in at least a part of an inner circumferential area of the opening an adequately rigid upper window frame, an elastically deformable lower window frame and a temporary fitting portion that allows the window member to be inserted between the upper and lower window frames, the base and the window member being molded to such that the upper window frame or the lower window frame around the opening in the base or the window member has a projection in a position where the upper window frame or the lower window frame contacts the window member;

[0055] inserting the window member into the temporary fitting portion around the opening in the base so that the lower window frame deforms elastically to achieve temporary joint between the window member and the base; and

[0056] allowing ultrasonic waves or heat to act on the temporary joint.

[0057] In order to attain the primary objective described above, according to a third aspect of the invention, there is provided a magnetic tape cassette having:

[0058] a base with an opening for forming a transparent window; and

[0059] a transparent resin-made window member to close the opening in the base, wherein

[0060] the base and the window member are composed of materials having no compatibility or having an extremely low degree of compatibility to each other, and wherein

[0061] the window member comprises a portion that is formed with a first sliding member of a die assembly for molding the base and a portion that is formed with a second sliding member of the die assembly, the window member having such a shape that the base is retained between the two portions.

[0062] According to the third aspect of the invention, there is also provided a magnetic tape cassette having:

[0063] a base with an opening for forming a transparent window; and

[0064] a transparent resin-made window member to close the opening in the base, wherein

[0065] the base and the window member are composed of materials having no compatibility or having an extremely low degree of compatibility to each other, the opening in the base ridges that engage the window member, the window member has recesses in at least one of two sets of opposed sides which fit the ridge on the base, and wherein the ridge on the base is fitted into the recess in the window member.

[0066] According to the third aspect of the invention, there is further provided a process for producing a magnetic tape cassette having a base with an opening for forming a transparent window and a transparent resin-made window member to close the opening in the base, comprising the steps of:

[0067] preparing a die assembly for molding the base which has a first sliding member which can be moved from one side of the base in order to form the opening and a second sliding member which can be moved from the other side of the base and which has at both ends recesses for providing the opening with ridges that engage the window member;

[0068] bringing the first sliding member into intimate contact with the second sliding member;

[0069] injecting a base forming material to mold the base having the opening;

[0070] causing the first sliding member and the second sliding member to be spaced apart; and

[0071] injecting into a resulting space a window member forming material that has no compatibility or has an extremely low degree of compatibility with the base forming material, whereby the window member is molded as an integral part of the base.

[0072] More specifically, the magnetic tape cassette according to the third aspect is of such a cross-sectional shape that it has recesses in the inner surfaces on both sides of the opening in the base, the recesses being interconnected by an edge portion. To manufacture the magnetic tape cassette having the base with this opening and the window member made of a transparent resin that closes the opening in the base, the following process is preferably employed: the base is molded with a die assembly having a first sliding member (cavity or core) that forms the recess in the front surface of the base and a second sliding member (cavity or core) that forms the recess in the back surface of the base and the opening, the first and second sliding members being both movable, and the first and second sliding members are advanced until they intimately contact each other and the recesses in the inner surfaces on both sides of the opening in the base and the edge portion interconnecting the recesses are molded, whereas the transparent window is molded with the same die assembly as above by injecting a transparent resin having no compatibility or having an extremely low degree of compatibility with the base molding resin into the

space defined by retracting the first and second sliding members, whereupon the transparent window is molded as an integral part of the base.

[0073] In order to attain the second objective described above, according to a fourth aspect of the invention, there is provided a magnetic tape cassette having:

[0074] a resin-made base with an opening for forming a transparent window; and

[0075] a transparent resin-made window member to close the opening in the base, wherein

[0076] respective resin-made parts of the magnetic tape cassette including at least the base and the window member are molded in multiple colors with a single die assembly using at least two incompatible resin materials that are not adherent to each other and, thereafter,

[0077] the respective resin-made parts are demolded and recombined from predetermined directions, whereby

[0078] the respective resin-made parts are assembled together in one step.

[0079] In the second, third and fourth aspects, it is preferable that the base is made of an ABS resin and that the window member is made of a transparent AS resin.

[0080] In order to attain the second objective described above, according to the fourth aspect of the invention, there is also provided a method for molding a resin product in multiple colors using at least two resins, comprising the steps of:

[0081] molding respective parts of the resin product in multiple colors with a single die assembly using at least two incompatible resin materials that are not adherent to each other; and thereafter

[0082] demolding the respective parts and recombining the respective parts from predetermined directions, thereby assembling the respective parts together in one step to produce the resin product.

[0083] In order to attain the primary objective described above, according to a fifth aspect of the invention, there is provided a magnetic tape cassette having:

[0084] a base with an opening for forming a transparent window;

[0085] a transparent material-made window member to be installed in the opening; and

[0086] joining means provided on either the base or the window member or both in order to install the window member within the opening in the base.

[0087] In a first embodiment of the fifth aspect, it is preferable that the joining means comprises a first wedge-shaped projection on an inner perimeter of the base around the opening which forms the window and a second wedge-shaped projection on the outer perimeter of the window member, and that the first projection on the base is brought into engagement with the second projection on the window member, whereby the window is installed within the opening in the base.

[0088] In the first embodiment of the fifth aspect of the invention, it is preferable that the joining means comprises

a window frame for supporting the window member on an inner perimeter of the base around the opening and an engaging pawl that is so shaped as to fit to the base and which holds the window frame of the base by engaging its lower edge, and that the engaging pawl of the window member is brought into engagement with the window frame of the base so that the window member is installed within the opening in the base.

[0089] Further, in the first embodiment of the fifth aspect of the invention, the joining means preferably comprises two sets of engaging members, one set consisting of the first wedge-shaped projection provided on the inner periphery of the opening in the base and the second wedge-shaped projection provided on the outer periphery of the window member and the other set consisting of the window frame provided on the inner periphery of the opening in the base and the engaging pawl provided on the outer periphery of the window member, and the first projection on the base is brought into engagement with the second projection on the window member whereas the engaging pawl on the window member is brought into engagement with the window frame on the base so that the window member is fitted into the opening in the base.

[0090] According to a second embodiment of the fifth aspect of the invention, a joint portion established by the joining means between the window member and the opening in the base has preferably a generally V-shaped cross section with an inclined portion.

[0091] Stated specifically, the cassette case according to the second embodiment of the fifth aspect of the invention is characterized in that the transparent window in the cassette case is one that is provided in the upper half of the cassette case in order to enable visual checking of the residual amount of magnetic tape as it is wound around take-up hubs, that the cassette case has the body of the upper half which serves as the base having the opening in which the transparent window is to be fitted and the window member that is made of a transparent resin and which closes the opening in the body of the upper half, and that the joint between the opening in the body of the upper half and the window member has a generally V-shaped cross section with an inclined portion.

[0092] With this design, the window member may be pushed at an angle from the inside, whereupon it becomes separable from the opening in the base. The generally V-shaped cross section with an inclined portion is preferably of such a shape that the opening in the base has an inwardly extending projection.

[0093] In the second embodiment of the fifth aspect of the invention, the term "generally V-shaped" (hereunder referred to simply as "V-shaped") refers to a state where two planes are opposed at an angle, at least one of which is parallel to the upper and lower surfaces of the upper half's body whereas the other plane forms a specified angle with the one plane. The specified angle refers to a range of angles over which smooth fitting can be accomplished upon pressing and the preferred value is typically at least 30 degrees.

[0094] In the second embodiment of the fifth aspect of the invention, it is also preferable that an inner perimeter of the opening in the base is shaped in a circular form, an outer perimeter of the window member is shaped in a circular

form so that it can be installed with the circular opening in the base, and that the engaging means comprises an engaging projection provided on either the inner circular perimeter of the opening or the outer circular perimeter of the window member and an engaging portion provided on either the outer circular perimeter of the window member or the inner circular perimeter of the opening to come into engagement with the engaging projection, the window member being fitted into the opening in the base and rotated until it is secured in such a way as to close the opening.

[0095] Stated specifically, the magnetic tape cassette according to the second embodiment of the fifth aspect of the invention is one having a base with an opening and a window member made of a transparent resin that closes the opening in the base, characterized in that an engaging projection is provided on either the inner peripheral surface of the opening or the outer peripheral surface of the window member whereas an engaging portion that comes into engagement with the engaging projection is provided on either the outer peripheral surface of the window member or the inner peripheral surface of the opening and that the window member is fitted into the opening in the base and rotated to become fixed in position.

[0096] Preferably, the base is the body of the upper half of the magnetic tape cassette and the transparent window is provided in two positions that correspond to the take-up hubs in the magnetic tape cassette.

[0097] In a more preferred case, the engaging projection and the engaging portion to be provided on the inner peripheral surface of the opening and on the outer peripheral surface of the window member are such that the engaging projection is provided on the outer peripheral surface of the window member whereas the engaging portion in a helical or partially helical form is provided on the inner peripheral surface of the opening or that the engaging portion in a helical or partially helical form is provided on the outer peripheral surface of the window member whereas the engaging projection is provided on the inner peripheral surface of the opening and that the window member is fitted into the opening in the base and rotated so that it is screwed up to become fixed in position.

[0098] In order to attain the third objective described above, according to a sixth aspect of the invention, there is provided a shaped resin article composed of members made of different materials and which has a plate-form member integrated into a housing in such a way that the plate-form member and the housing can be easily separated from each other, wherein vertically offset projections are provided on each of the opposed sides of a portion of the housing which is to receive the plate-form member such that each end portion of the plate-form member can be held between an upper row of projections and a lower row of projections and wherein the plate-form member can be integrated by being inserted between the upper and lower rows of projections only from one direction with respect to the portion of the housing which is to receive the plate-form member.

[0099] The shaped resin article according to the sixth aspect of the invention is a magnetic tape cassette having a base with an opening and a window member made of a transparent material which is to be fitted into the opening in the base, characterized in that vertically offset projections are provided on each of the opposed sides of the opening in

the base such that each end portion of the window member can be held between an upper row of projections and a lower row of projections and that the window member can be integrated by being inserted between the upper and lower rows of projections only from one direction with respect to the opening in the base.

[0100] In order to attain the primary objective described above, according to a seventh aspect of the invention, there is provided a magnetic tape cassette having:

[0101] a base with an opening for forming a transparent window;

[0102] and a transparent material-made window member to be installed in the opening, wherein

[0103] the window member is installed within the opening and

[0104] a manipulating engaging portion effective in the step of separating the transparent window is provided on the window member or in that area of the base which contacts the window member.

[0105] While the manipulating engaging portion may be provided in various areas, it is preferably in an end portion of the window member.

[0106] The manipulating engaging portion may be provided in various forms but it is preferably a groove that is provided in the base as an aid in dislodging an engaging means.

[0107] In order to attain the fourth objective of the invention, according to an eighth aspect of the invention, there is provided a magnetic tape cassette having:

[0108] a base with one or more openings for forming transparent windows; and

[0109] one or more transparent resin-made window members to be installed in the one or more openings, wherein

[0110] the window member is made of a biodegradable resin and fitted within at least one of the one or more openings in the base.

[0111] In order to attain the fifth objective of the invention, according to a ninth aspect of the invention, there is provided a method for destructing, separating and recovering two or more parts of a shaped resin article which have been molded of dissimilar materials, wherein one of the parts to be separated for recovery is provided with a specified mark in a specified position on the part which is related to the position of a gate on the part for injecting molding the part and which, if it is given an impact, becomes a start point for a crack to propagate toward the position of the gate and wherein upon application of an impact to the position of the specified mark, the parts molded of the dissimilar materials can be separated for recovery without using a special tool.

[0112] The shaped resin article is a magnetic tape cassette comprising a cassette case that has an upper half and a lower half joined together in a face-to-face relationship and which contains magnetic tape wound around a reel, characterized in that the body of the upper half serving as the base has an opening for forming a transparent window and a window member as a window constituting part made of a transparent material, the window member being provided with a specified mark in a specified position on the part which is related

to the position of a gate on the part for injection molding the part and which, if it is given an impact, becomes a start point for a crack to propagate toward the position of the gate.

[0113] In each of the foregoing aspects of the invention, the base is preferably the body of the upper half and it is preferably the upper half that comprises this body and the window member.

BRIEF DESCRIPTION OF THE DRAWINGS

[0114] FIG. 1 is an exploded perspective view showing a magnetic tape cassette according to an example of a first embodiment of the fifth aspect of the present invention;

[0115] FIG. 2 is a perspective view showing in section the upper half of the magnetic tape cassette of FIG. 1 as it is cut through the transparent window along line I-I;

[0116] FIG. 3 is a partial section of the upper half shown in FIG. 2;

[0117] FIG. 4A is a partial enlarged sectional view showing how a wedge-shaped projection on the body of the upper half shown in FIG. 3 is in engagement with a wedge-shaped projection on the window member;

[0118] FIG. 4B is a partial enlarged sectional view showing a modification of the case shown in FIG. 4A;

[0119] FIG. 5 is a sectional view of the upper half of a magnetic tape cassette according to another example of the first embodiment of the fifth aspect of the invention;

[0120] FIG. 6A is an enlarged sectional view showing how a window frame on the body of the upper half shown in FIG. 5 is in engagement with a pawl member on the window member;

[0121] FIG. 6B is an enlarged sectional view showing a modification of the case shown in FIG. 6A;

[0122] FIG. 7 is a sectional view of the upper half of a magnetic tape cassette according to yet another example of the first embodiment of the fifth aspect of the invention;

[0123] FIG. 8 is a perspective view of the window member in the example shown in FIG. 7;

[0124] FIG. 9 is a partial enlarged perspective view of a window member engaging portion provided in the upper half of a magnetic tape cassette according to one example of the first aspect of the invention;

[0125] FIG. 10 is a perspective view of a window member having an engaging member that is engaged by the window member engaging portion of the upper half shown in FIG. 9;

[0126] FIG. 11 is a section of the window member and the window member engaging portion of the upper half as it is taken along the imaginary center line in FIG. 9;

[0127] FIGS. 12A, 12B and 12C are schematic views illustrating the process of fitting the window member according to the first aspect of the invention into the window member engaging portion of the upper half;

[0128] FIGS. 13A, 13B and 13C are schematic views illustrating the process of removing the window member according to the first aspect of the invention from the window member engaging portion of the upper half;

[0129] FIGS. 14A, 14B, 14C and 14D are perspective views showing four different shapes of the engaging member provided on lateral sides of the window member according to the first aspect of the invention;

[0130] FIG. 15 is a sectional view showing further details of the engaging grooves in the window member engaging portion of the example shown in FIG. 9;

[0131] FIGS. 16A and 16B are sectional views showing details of two additional examples of the engaging grooves in the window member engaging portion of the body of the upper half according to the first aspect of the invention;

[0132] FIG. 17 is a sectional view showing details of yet another example of the engaging grooves in the window member engaging portion of the body of the upper half according to the first aspect of the invention;

[0133] FIG. 18 is a sectional view of a transparent window portion of the upper half according to a first example of a second embodiment of the fifth aspect of the invention;

[0134] FIG. 19 is a section of the same transparent window except that it is taken through a plane perpendicular to the plane through which FIG. 18 was taken;

[0135] FIG. 20 is a perspective view showing details of a portion of the upper half into which the transparent window is to be fitted according to a second example of the second embodiment of the fifth aspect of the invention;

[0136] FIG. 21 is a perspective view showing diagrammatically an example of the magnetic tape cassette according to the sixth aspect of the invention;

[0137] FIG. 22 is section III-III of FIG. 21;

[0138] FIG. 23 is section IV-IV of FIG. 21;

[0139] FIG. 24 is a perspective view showing enlarged a part of a window receiving portion of the upper half of the magnetic tape cassette according to the same example;

[0140] FIG. 25 is a perspective view showing the window as it has been integrated into the upper half shown in FIG. 24;

[0141] FIG. 26 is a perspective view of the window used in the same example;

[0142] FIG. 27 is a perspective view of the magnetic tape cassette that is adapted for the method of fitting the window in the same example;

[0143] FIG. 28 is a perspective view showing a modification of the window that can be used in the same example;

[0144] FIG. 29 is a perspective view showing the upper half of a magnetic tape cassette having two transparent windows according an example of a third embodiment of the fifth aspect of the invention;

[0145] FIG. 30 is section V-V of FIG. 29 showing the upper half as it holds the transparent windows;

[0146] FIG. 31 is a side view of the window member shown in FIG. 30;

[0147] FIG. 32 is a perspective view of the window member as it is seen from the bottom;

[0148] FIGS. 33A and 33B are a perspective view and a side view, respectively, which show a transparent window in

a magnetic tape cassette according to another example of the third embodiment of the fifth aspect of the invention;

[0149] **FIG. 34** is a perspective view showing the opening in the upper half according to the example shown in **FIG. 33**;

[0150] **FIG. 35** illustrates how the window member is in engagement with the inner peripheral surface of the opening according to the example shown in **FIG. 33**;

[0151] **FIG. 36** is a perspective view showing a magnetic tape cassette having a separable transparent window according to an example of the second aspect of the invention;

[0152] **FIG. 37** is a perspective view showing in section the upper half of the magnetic tape cassette shown in **FIG. 36** as it is cut through the transparent window along line VI-VI;

[0153] **FIG. 38** is section VII-VII of the upper half shown in **FIG. 37**;

[0154] **FIG. 39** is section VII-VII of the window member of the transparent window shown in **FIG. 37**;

[0155] **FIG. 40** is a sectional view of the window member shown in **FIG. 39** as it is joined temporarily after having been inserted into grooves in the upper half;

[0156] **FIG. 41** is a sectional view of the secure joint formed by ultrasonic or thermal welding of the temporary joint shown in **FIG. 40**;

[0157] **FIG. 42** is a perspective view showing in section a transparent window in the upper half of a magnetic tape cassette according to another example of the second aspect of the invention;

[0158] **FIG. 43** is a fragmentary perspective view showing the upper half of a magnetic tape cassette according to a first embodiment of the third aspect of the invention;

[0159] **FIG. 44** is a sectional view of a transparent window in the upper half shown in **FIG. 43**;

[0160] **FIGS. 45A and 45B** are sectional views showing relative movements of molding dies intended to illustrate an example of the process for fabricating the transparent window in the upper half shown in **FIG. 44**;

[0161] **FIG. 46** is a sectional view showing a window portion of the upper half in a magnetic tape cassette according to another embodiment of the third aspect of the invention and the die assembly for molding the window portion;

[0162] **FIG. 47** is a plan view showing the upper half of a magnetic tape cassette according to an example of the fourth aspect of the invention and the residual tape check window provided in this upper half;

[0163] **FIG. 48** is section VIII-VIII of **FIG. 47** showing how the upper half is combined with the window;

[0164] **FIG. 49** is a perspective view showing enlarged the upper half and window combination shown in **FIG. 47**;

[0165] **FIG. 50** is a perspective view showing enlarged a part of the upper half according to the fourth aspect of the invention;

[0166] **FIG. 51** is a perspective view showing enlarged a part of the window according to the fourth aspect of the invention;

[0167] **FIG. 52** is an enlarged perspective view showing the window as it has been molded simultaneously with the upper half according to the fourth aspect of the invention;

[0168] **FIGS. 53A and 53B** are sections of a mold that correspond to section IX-IX of **FIG. 52**;

[0169] **FIG. 53C** is a perspective view of a moving core;

[0170] **FIG. 54** is an enlarged perspective view of the window as it has been installed in the upper half according to the fourth aspect of the invention;

[0171] **FIG. 55** is an enlarged perspective view showing, with part taken away, a manipulating engaging portion provided in the upper half of a magnetic tape cassette according to an example of the seventh aspect of the invention;

[0172] **FIG. 56** is a longitudinal section of the upper half shown in **FIG. 55**;

[0173] **FIG. 57** is a perspective view showing another example of the transparent window in the upper half according to the seventh aspect of the invention;

[0174] **FIGS. 58A and 58B** are sections of two examples of the engagement between the window and the upper half as they are cut through **FIG. 57** along line XI-XI;

[0175] **FIG. 59** is a perspective view showing diagrammatically a magnetic tape cassette according to an example of the ninth aspect of the invention;

[0176] **FIG. 60** is an illustration of the breaking behavior of a common shaped resin article;

[0177] **FIG. 61** is a perspective view showing an example of the window according to the ninth aspect of the invention;

[0178] **FIG. 62** is a perspective view showing another example of the window according to the ninth aspect of the invention;

[0179] **FIG. 63** is a perspective view showing yet another example of the window according to the ninth aspect of the invention;

[0180] **FIG. 64** is a perspective view showing a still another example of the window according to the ninth aspect of the invention;

[0181] **FIG. 65** is a perspective view showing diagrammatically a common magnetic tape cassette;

[0182] **FIGS. 66A and 66B** illustrate a conventional method for molding the upper half and the window of the magnetic tape cassette;

[0183] **FIG. 67** is a perspective view of a prior art upper half, with it being cut across the transparent window; and

[0184] **FIG. 68** is a section of **FIG. 67** showing the upper half together with the transparent window.

[0185] On the following pages, the magnetic tape cassette of the present invention, the process for its manufacture, the shaped resin article, the method for multi-color molding of resin products and the method for destructing and separating

parts made of dissimilar materials are described in detail with reference to the preferred examples shown in accompanying drawings.

[0186] First, we refer to **FIGS. 1-8** and describe the magnetic tape cassettes according to the fifth aspect of the invention, particularly its first embodiment.

[0187] **FIG. 1** is an exploded perspective view of a magnetic tape cassette with a transparent window according to a first example of the first embodiment of the fifth aspect of the invention. **FIG. 2** is a perspective view showing in section the upper half of the magnetic tape cassette of **FIG. 1** as it is cut through the transparent window along line I-I. **FIG. 3** is a partial section of the upper half shown in **FIG. 2**. **FIGS. 4A and 4B** are partial enlarged sections showing two examples of the engagement between a first wedge-shaped projection on the body of the upper half (hereunder sometimes referred to as the base) and a second wedge-shaped projection on a window member.

[0188] The magnetic tape cassette with the transparent window according to the first example of the first embodiment of the fifth aspect of the invention is generally indicated by **10** in **FIG. 1**. As shown, a length of magnetic tape **12** is securely attached to a pair of take-up hubs **14, 14** at its ends and the remainder of tape length is wound around the respective take-up hubs **14, 14**. The pair of take-up hubs **14, 14** around which the magnetic tape **12** has been wound is placed rotatably within a cassette case which is the combination of an upper half **16** and a lower half **18**. The magnetic tape **12** is threaded in a specified path to be stretched between the two hubs such that only a portion **12a** of the tape that is in a position which corresponds to the magnetic head on a record/reproduce apparatus (not shown) would otherwise be exposed to the outside.

[0189] In order to cover and protect the magnetic layer of the portion **12a** of the magnetic tape which would otherwise become exposed to the outside of the cassette case, the upper half **16** is fitted with a front cover (lid) **22** that is axially supported by pins **20** and capable of pivoting between two positions, the CLOSE position where it covers the portion **12a** of the magnetic tape and the OPEN position where it lets the portion **12a** become exposed. The lid **22** is urged toward the CLOSE position by means of a torsion coil spring (not shown).

[0190] The lower half **18** has a rectangular bottom plate **24** which in turn has reel shaft insertion holes **26, 26** in the center; the reel shaft insertion holes **26, 26** rotatably support the pair of take-up hubs **14, 14** around which the magnetic tape **12** has been wound; in addition, when the magnetic tape cassette under consideration is loaded in a record/reproduce apparatus (not shown), the reel shafts (also not shown) on the apparatus pass through the holes **26, 26** into the take-up hubs, thereby driving them to rotate.

[0191] The bottom plate **24** has two forward extensions **28, 28** at the right and left ends. The extensions **28, 28** have cylindrical tape guides **30, 30** erected vertically on the bottom plate **24**; the magnetic tape **12** stretched between the take-up hubs **14, 14** is guided by means of the cylindrical tape guides **30, 30** such that it is threaded in a specified path to reach the front of the cassette case. The bottom plate **24** is cut out in the area between the two extensions **28, 28**, leaving an opening in the cassette case.

[0192] Positioning pins (not shown) on the upper half **16** are inserted into the tape guides **30, 30** to achieve registration. The tape guides **30, 30** also serve as screw bosses through which screws (also not shown) are pushed from below into the threaded holes in the centers of the positioning pins and tightened to hold the upper half **16** and the lower half **18** together in secure position. Screw bosses **32, 32** having a similar structure to the tape guides **30, 30** are provided in the back at right and left corners of the lower half **18**. By inserting screws into these four bosses and tightening them up, the cassette halves having the magnetic tape **12** and other components installed therein are securely held together to provide the magnetic tape cassette **10**.

[0193] A slider generally indicated by **34** has a thin flat bottom plate **36** that is brought into contact with the underside of the bottom plate **24** of the lower half **18**. When the cassette is not in service, the bottom plate **36** closes, for dust prevention, the open areas in the underside of the cassette case, namely, the opening in the lower half **18** and the reel shaft insertion holes **26, 26**. Being guided by sidewalls **38, 38** of the lower half **18**, the bottom plate **36** is capable of moving back and forth to slide along the underside of the lower half **18**. If it moves forward, the bottom plate **36** closes the opening in the cassette case and the reel shaft insertion holes **26, 26**; if it moves backward, the bottom plate **36** clears the opening in the cassette case and, at the same time, the reel shaft insertion holes **26, 26** in the lower half **18** come into registry with reel shaft insertion holes **40, 40** in the slider **34**, making the cassette case ready for insertion of the aforementioned reel shafts on the record/reproduce apparatus.

[0194] The bottom plate **24** of the lower half **18** has a mid-wall **42** curved in arched form along the magnetic tape **12** wound around the take-up hubs **14**. A leaf spring mount **44** is erected in front of a recess formed at the center junction of two arched halves of the mid-wall **42**; a slider spring **46** in the form of a leaf spring is inserted between the recess at the center junction of the mid-wall **42** and the leaf spring mount **44** and it pushes ribs **48** at the front of the slider **34**, whereby it is urged forward (in the direction of closing the slider **34**).

[0195] A gear wheel **50** is provided in the center of each take-up hub **14**. A braking member **52** provided on the upper half **16** has braking tabs **54** which engage the gear wheels **50, 50** to form an anti-rotation mechanism that prevents the take-up hubs **14, 14** from rotating when the magnetic tape cassette **10** is not in service. The upper half **16** has a transparent window through which the operator can visually check the amount by which the magnetic tape **12** has been wound onto the take-up hubs **14, 14**. To make the transparent window, an opening is formed in the upper half's body **56** and a window member **58** made of a transparent resin (plastic material) is fitted in this opening.

[0196] **FIG. 2** is a perspective view showing in section the upper half **16** of the magnetic tape cassette **10** as it is cut through the transparent window along line I-I in **FIG. 1**. As shown, the transparent window in the upper half **16** consists of an opening **56a** formed in the body **56** of the upper half **16** as a window and a window member **58** that is made of a transparent resin and fitted in the opening **56a**.

[0197] As shown in detail in **FIGS. 3 and 4**, the opening **56a** formed in the upper half's body **56** has a first wedge-

shaped projection **56b** on the inner periphery that defines the transparent window. The window member **58** is of such a shape that it can be fitted in the upper half's body **56** and it has a second wedge-shaped projection **58a** on the outer periphery.

[0198] The projection **56b** on the upper half's body **56** and the projection **58a** on the window member **58** are both wedge-shaped, so as shown in **FIGS. 4A and 4B**, when the window member **58** is pressed from above into the opening **56a**, the wedge-shaped projection **58a** undergoing elastic deformation rides over the similarly wedge-shaped projection **56b** also undergoing elastic deformation and, once the window member **58** has been fitted in the opening **56a**, the two projections engage each other and the window member **58** will no longer be dislodged from the upper half's body **56**. The wedge-shaped projection **56b** on the upper half's body **56** and the wedge-shaped projection **58a** on the window member **58** are provided intermittently in the same positions in order to ensure mutual engagement.

[0199] The window member **58** is the least likely to be dislodged from the upper half's body **56** if the two wedge-shaped projections **56b**, **58a** are so formed that their mating surfaces make intimate contact with each other as shown in **FIG. 4A**; however, due to a certain factor such as dimensional variations, positive engagement may occasionally be difficult to achieve or the window member **58** may sometimes rattle because of the failure of two projections to have intimate contact. In order to prevent these problems, at least one of the two mating surfaces may be formed at an angle as shown in **FIG. 4B**; this eliminates the difficulty in achieving positive engagement and prevents the window member **58** from rattling on account of the failure to have intimate contact with the upper half's body **56**. The angle of inclination can be determined at an appropriate value considering several factors such as the variations in the dimensions of the wedge-shaped projection **56b** on the upper half's body **56** and the wedge-shaped projection **58a** on the window member **58**.

[0200] According to the above-described first example of the first embodiment of the fifth aspect of the invention, one can produce a magnetic tape cassette characterized in that the window member can be easily separated from the body of the upper half, that the recovered upper half and window member can be recycled as feeds for additional products without suffering a drop in purity, and that the separating operation can be performed efficiently.

[0201] **FIG. 5** is a sectional view of the upper half of a magnetic tape cassette according to a second example of the first embodiment of the fifth aspect of the invention. **FIGS. 6A and 6B** are enlarged sectional views showing how a window frame on the body of the upper half is in engagement with a pawl member on the window member. The second example under consideration relates to another case of the means for bringing the window member **58** into engagement with the opening **56a** in the upper half's body **56** of the magnetic tape cassette.

[0202] In the magnetic tape cassette under consideration, a window frame **56c** is provided on the inner periphery of the opening **56a** in the upper half's body **56**, and an engaging pawl **58b** which holds the window frame **56c** by engaging its lower edge is provided on the window member **58**. If the window member **58** is pressed into the opening **56a** from

above, the engaging pawl **58b** on the window member **58** engages the window frame **56c** on the upper half's body **56** by snap fit so that the window member **58** is installed into the opening **56a** in the upper half's body **56**.

[0203] As shown in **FIGS. 6A and 6B**, the engaging pawl **58b** on the window member **58** is so shaped that when it is in engagement with the window frame **56c** formed in the lower part of the inner periphery of the opening **56a** in the upper half's body **56**, it holds the window frame **56c** by engaging its lower edge. Usually, the upper half's body **56** is so formed that its underside is flush with the underside of the window frame **56c**.

[0204] In the design described above, the engaging pawl **58b** on the window member **58** projects from the underside of the upper half's body **56**. If this should be avoided, the design shown in **FIG. 6B** may be adopted; a groove is formed such that the underside of the window frame **56c** is recessed from the underside of the upper half's body **56** and the mating surface of the window frame **56c** is provided within the groove; similarly, the engaging pawl **58b** on the window member **58** is recessed by the same distance and a suitable groove is provided around the pawl; in consequence, the engaging pawl **58b** will not project from the underside of the upper half's body **56**.

[0205] As in the first example, at least one of the mating surfaces of the window frame **56c** and the engaging pawl **58b** may be formed at an angle and this contributes to achieving not only positive engagement but also intimate contact between the window member **58** and the upper half's body **56**.

[0206] According to the above-described second example of the first embodiment of the fifth aspect of the invention, one can produce a magnetic tape cassette characterized in that the window member can be easily separated from the body of the upper half, that the recovered upper half and window member can be recycled as feeds for additional products without suffering a drop in purity, and that the separating operation can be performed efficiently.

[0207] **FIG. 7** relates to a third example of the magnetic tape cassette according to the first embodiment of the fifth aspect of the invention and it shows means for engaging the opening **56a** in the upper half's body **56** with the window member **58**. Briefly, in this third example, the engaging means of the first example characterized in that it holds the window member **58** by brining the wedge-shaped projection **56b** on the inner periphery of the opening **56a** in the upper half's body **56** into engagement with the wedge-shaped projection **58a** on the outer periphery of the window member **58** is combined with the second example in which the window member **58** is held by the engaging pawl **58b** on the window member **58** which applies to snap fit the window frame **56c** formed in the lower part of the opening **56a** in the upper half's body **56**.

[0208] In **FIG. 7**, the wedge-shaped projection **58a** and the engaging pawl **58b** that are formed on the outer periphery of the window member **58** are shown to overlap in the same position. In fact, however, the wedge-shaped projection **58a** and the engaging pawl **58b** are desirably distributed in different positions on the outer periphery of the window member **58** as shown in **FIG. 8** which is a perspective view of the window member **58**. By adopting the design of the

third example, the advantages of both the first and second examples are retained and one can fabricate a magnetic tape cassette having a transparent window that has even better fit to the body of the upper half of the cassette.

[0209] Described above are the basic features of the design of the magnetic tape cassette according to the first embodiment of the fifth aspect of the invention.

[0210] We next describe the magnetic tape cassette according to the first aspect of the invention with reference to FIGS. 9-17.

[0211] The magnetic tape cassette according to the first aspect of the invention is characterized in that the transparent window is provided in the upper half of the cassette by pressing the window member into the opening in the base (the body of the upper half) at an angle until it is fixed in position. Except for the mechanism by which the window member forming the transparent window in the upper half is fitted into the opening in the body of the upper half and fixed in position, the magnetic tape cassette according to the first aspect of the invention has essentially the same construction as the one shown in FIG. 1; therefore, on the following pages, we describe only this mechanism in detail and omit the description of other parts.

[0212] FIG. 9 is an enlarged perspective view of an example of a window member engaging portion provided in the upper half of a first embodiment of the magnetic tape cassette according to the first aspect of the invention. FIG. 10 is a perspective view of an example of a window member having engaging members that are to be engaged by the window member engaging portion on the upper half which is shown in FIG. 9.

[0213] The window member generally indicated by 178 in FIG. 10 has engaging members 178a on a set of two opposed sides and dust-proof stepped portions 178b on the other set of two opposed sides. The two sides of the window member 178 on which the engaging members 178a are provided are rendered dust-proof by means of a dust-preventing flange 178c. The top surface of FIG. 10 shall face outward of the upper half of the magnetic tape cassette.

[0214] Part of the dust-preventing flange 178c is extended across the window member 178 to provide areas (178d) by means of which reel springs which depress the tape winding reels toward the lower half can be held between the areas 178d and the upper half as the window member 178 is fitted into the opening in the upper half's body 176.

[0215] The window member engaging portion of the upper half's body 176 which is shown in FIG. 9 corresponds to the window member 178 and in that portion (i.e., around the opening in the upper half's body 176) are formed engaging grooves 176a that come into engagement with the engaging members 178a on the window member 178, as well as stepped portions 176b that correspond to the stepped portions 178b. The engaging members 178a engage the engaging grooves 176a and the stepped portions 178b come into engagement with the stepped portions 176b, thereby achieving effective engagement between the window member 178 and the upper half's body 176 while securing against the entrance of dust into the upper half.

[0216] The mechanism for achieving engagement between the window member engaging portion and the window

member that are respectively shown in FIGS. 9 and 10 is such that the engaging members 178a on the window member 178 are slid along the inner surfaces of the upper half's body 176 into the engaging grooves 176a in the window member engaging portion shown in FIG. 9, with the angles of inclination being in registry, and a force is applied in the same direction, whereupon the window member 178 is brought into engagement with the window member engaging portion of the upper half's body 176. As will be described later, at the final stage of this engaging action, the stepped portions 178b of the window member 178 will fit to the stepped portions 176b of the window member engaging portion of the upper half's body 176 in a substantially vertical direction.

[0217] The above-described action for engaging the window member in the example under consideration may be regarded as consisting of two stages and in spite of the relatively easy fitting action, the window member engaging portion can realize a strong enough fit and, in addition, in order to separate the window member from the upper half, the user must first apply a vertical force to cancel the engagement between the stepped portions and only thereafter does he cancel the engaging members and the engaging grooves by applying a force at a specified angle. This is indeed a measure that secures utmost safety.

[0218] A more specific description is given below with reference to FIG. 11 which shows in section the engagement between the window member engaging portion of the upper half's body 176 and the window member 178 as it is cut through FIG. 9 along the imaginary line II-II. As shown in detail in FIG. 11, the window member 178 in engagement with the window member engaging portion of the upper half's body 176 is such that stepped sides 179a, 179b of the window member 178 (in the upper part) abut stepped sides 181a, 181b of the window member engaging portion of the upper half's body 176 (in the upper part) whereas stepped sides 180a, 180b of the window member 178 (in the lower part) abut stepped sides 182a, 182b of the window engaging portion of the upper half's body 176 (in the lower part), whereupon the window member 178 is positioned exactly with respect to the upper half's body 176 (particularly to the window member engaging portion).

[0219] As already mentioned, it is basically at a specified angle that the window member 178 can be removed from the upper half's body 176 (particularly from the window member engaging portion). However, the horizontal component of a force applied at an angle is constrained by the above-mentioned abutting sides, so the window member 178 must first be depressed in a vertical direction from the outer surface of the upper half (from below in FIG. 11) in order to remove the constraint and then a force is applied at the specified angle in order to remove the window member 178 from the upper half's body 176.

[0220] FIGS. 12A-12C show schematically how the window member 178 is fitted in the window member engaging portion of the upper half's body 176.

[0221] As shown, in the example under consideration, the window member 178 may be fitted at a specified angle into the window member engaging portion of the upper half's body 176 in successive steps.

[0222] FIGS. 13A-13C show schematically how the window member 178 is removed from the window engaging portion of the upper half's body 176.

[0223] As shown in **FIG. 13A**, in order to remove the window member from the window member engaging portion, one end of the window member **178** is pushed up vertically and then as shown in **FIGS. 13B and 13C**, it may be pulled up at the same specified angle as when it was fitted in the window member engaging portion.

[0224] It should be noted that as an ancillary to the action of fitting the window member **178**, the stepped portions **178b** of the window member **178** engage the stepped portions **176b** to provide a dust-proof structure for part of the area around the window member **178**. The flange **178c** of the window member **178** also provides a dust-proof structure for the remaining part of the area around the window member **178** (i.e., for the sides where the engaging members **178a** are present).

[0225] **FIGS. 14A-14D** show four examples of the shape of the engaging member **178a** to be provided on two sides of the window member **178**. **FIG. 14A** shows a most common type of a rectangular cross section that is rounded at both ends; **FIG. 14B** is similar to **FIG. 14A** except that both sides are chipped to give an oval shape that is easier to fit in; **FIG. 14C** is a variant of **FIG. 14B** which is further tapered at the insertion end; **FIG. 14D** shows a shape which is much easier to fit in since it need be fitted in by a very short length.

[0226] The magnetic tape cassette according to the first aspect of the invention has the above-described construction, so when it is in service, the engaging members **178a** on the window member **178** remain in engagement with the engaging grooves **176a** in the inner surfaces of the opening in the upper half's body **176** and, at the same time, the stepped portions **176b** on the inner surfaces of the opening in the upper half's body **176** are in intimate contact with the stepped portions **178b** of the window member **178** and no practical problems will occur in terms of joint strength and air-tightness.

[0227] In the examples shown in **FIGS. 9 and 10**, the angle at which the engaging members **178a** on the window member **178** engage the engaging grooves **176a** in the inner surfaces of the opening in the upper half's body **176** is not given an exact definition but a preferred range is typically from about 10 to 45 degrees with the normal. The direction of inclination is preferably parallel to a longitudinal direction of the upper half's body **176**.

[0228] **FIG. 15** shows further details of the engaging grooves **176a** in the window member engaging portion of the upper half's body **176** according to the example shown in **FIG. 9**. As shown, the entrance **176ab** of each engaging groove **176a** (on the right side in **FIG. 15**) is preferably shaped to have a somewhat gentle lead so that the engaging member **178a** on the window member **178** can be easily inserted. Conversely, the exit **176aa** of each engaging groove **176a** (on the left side in **FIG. 15**) is preferably shaped to maintain a predetermined sharp angle so that the inserted engaging member **178a** will not be easily dislodged under a depressing force applied from a near-vertical direction.

[0229] **FIGS. 16A and 16B** are sectional views showing details of another example of the engaging grooves **176a** in the window member engaging portion of the upper half's body **176**. The shape of the engaging groove shown in **FIG.**

16A is effective in the case of using an engaging member of the type shown in **FIG. 14D** which has a generally circular cross section, namely, one having a short length in the direction in which it is to be fitted in. After the engaging member is fitted at a specified angle into the groove **176a** shown in **FIG. 16A**, the window member is preferably moved downward by a small amount in the vertical direction.

[0230] The shape of the engaging groove shown in **FIG. 16B** is also effective in the case of using an engaging member having a short length in the direction in which it is to be fitted in. Preferably, the engaging member is first moved downward vertically by a small amount and then it is fitted into the groove **176a** at a specified angle.

[0231] The engaging grooves **176a** in the window member engaging portion may adopt various other shapes including the combination of the shapes shown in **FIGS. 16A and 16B**.

[0232] **FIG. 17** shows still another example of the shape of the engaging groove **176a** in the window member engaging portion of the upper half's body **176** and the nearby area. In the example shown, the exit **176aa** of each engaging groove **176a** is further extended to form an extension **176ac**, thus providing a more positive engagement between the window member **178** and the upper half's body **176**.

[0233] The invention is by no means limited to the foregoing examples and engaging pawls of other structures may of course be adopted. It should also be understood that the same concept can equally be applied to various types of transparent window that are provided in other models of magnetic tape cassette as an aid in visual check of its interior.

[0234] Consider, for example, the engaging members **58a** that are provided two each on the right and left sides of the window member **58** in the foregoing examples. This is not the sole case of the invention and as long as they are provided at least one each on the right and left sides of the window member **58**, their number can appropriately be determined depending upon various factors including the size of the magnetic tape cassette and the size of the window. This is also the case for the width and depth of the stepped portions **58b** provided on the window member **58** and the stepped portions **56b** provided on the upper half's body **56**.

[0235] Described above is the basic structural features of the first aspect of the invention.

[0236] We next describe the magnetic tape cassette according to the second embodiment of the fifth aspect of the invention with reference to **FIGS. 18-20**.

[0237] Except for the structure of the transparent window in the upper half, the magnetic tape cassette according to the second embodiment of the fifth aspect of the invention has essentially the same construction as the one shown in **FIG. 1**; therefore, on the following pages, we describe only the structure of the transparent window in detail and omit the description of other parts.

[0238] **FIG. 18** shows an example of the transparent window in the cassette case according to the second embodiment of the fifth aspect of the invention and it is a section taken through the transparent window in the upper half in a longitudinal direction. **FIG. 19** is a section of the same

transparent window which is taken in a transverse direction perpendicular to the longitudinal direction. As is clear from these figures, the transparent window in the upper half consists of an opening **206a** formed as a window in the upper half's body **206** and a window member **208** that is formed of a transparent resin and which is fitted in the opening **206** to close it.

[0239] As shown in **FIG. 18** (which is a section of the transparent window taken in the longitudinal direction), the joint between the opening **206a** in the upper half's body **206** and the window member **208** has such a cross-sectional shape that a V-shaped projection joins to a correspondingly V-shaped recess at either end of their length. More specifically, the left end of the opening **206a** in the upper half's body **206** is of such a cross-sectional shape that it has a recess **206b** made in the upper surface, with a surface **206c** below the recess **206b** inclining downward to the left, so that a V-shaped projection **206d** is defined by the bottom of the recess **206b** and the inclined surface **206c**.

[0240] The term "V-shaped" as used herein refers to a state where two planes are opposed at an angle, at least one of which is parallel to the upper and lower surfaces of the upper half's body whereas the other plane forms a specified angle with the one plane. The specified angle refers to a range of angles over which smooth fitting can be accomplished upon pressing and the preferred value is typically at least 30 degrees.

[0241] The left end of the window member **208** which is to be fitted into the opening **206a** in the upper half's body **206** has a cross-sectional shape that corresponds to the above-described cross-sectional shape of the left end of the opening **206a** in the upper half's body **206**. Stated specifically, the upper surface forms a flange **208a** that is to be fitted into the recess **206b** in the upper half's body **206** and below this flange is provided an inclined surface **208b** that corresponds to the inclined surface **206c** of the upper half's body **206**; the lower surface of the flange **208a** and the inclined surface **208b** combine to form a V-shaped recess **208c** which corresponds to the V-shaped projection **206d** on the upper half's body **206**.

[0242] The right end of the opening **206a** in the upper half's body **206** has a cross-sectional shape which is an inversion of the cross-sectional shape of the left end. Stated specifically, the upper side of the opening **206a** in the upper half's body **206** has an inclined surface **206e** and the lower side has a recess **206f**, thereby forming a V-shaped projection **206g**. The right end of the window member **208** is of such a cross-sectional shape that the upper side has an inclined surface **208d** that corresponds to the inclined surface **206e** of the upper half's body **206** and below this flange is provided a flange **208e** that is to be fitted into the recess **206f** in the upper half's body **206**, thus forming a V-shaped recess **208f** which corresponds to the V-shaped projection **206g** on the upper half's body **206**. As shown in **FIG. 19**, a section of the transparent window at each of the joints to the upper half's body **206** as it is taken in a transverse direction perpendicular to the length has such a cross-sectional shape that a recess **206h** is provided in the upper surface of the upper half's body **206** around the opening **206a** and the flange **208g** of the window member **208** is fitted into the recess **206h**.

[0243] As described above, the joints between the opening **206a** in the upper half's body **206** and the window member

208 have such a cross-sectional shape that two sets of inclined V-shapes are combined together. In order to install the window member **208** into the opening **206a** in the upper half's body **206**, one may simply combine the V-shapes on the left side and press them down with great force, whereupon the projection **206g** and the flange **208e** deform elastically, allowing the window member **208** to be easily fitted into the opening **206a** in the upper half's body **206**.

[0244] Once the window member **208** has been fitted to the upper half's body **206**, the V-shaped projection **206d** on the upper half's body **206** comes into intimate contact with the V-shaped recess **208c** in the window member **208** and the V-shaped projection **206g** on the upper half's body **206** comes into intimate contact with the V-shaped recess **208f** in the window member **208** (see **FIG. 18** which shows both ends of the transparent window sectioned in the longitudinal direction) and, in addition, the flange **208g** of the window member **208** is brought into intimate contact with the recess **206h** in the upper surface of the upper half's body **206** around the opening **206a** (see **FIG. 19** which shows a cross-sectional shape of the transparent window as it is cut in a transverse direction perpendicular to the length). The resulting upper half is not only adequately air-tight, it also has sufficient strength against external forces (applied from above in the case shown in **FIGS. 18 and 19**).

[0245] In order to separate the window member **208** from the upper half's body **206** when the magnetic tape cassette is discarded after use, one may push the right end of the window member **208** by applying a strong force from the inside (from below as indicated by the arrow in **FIG. 18**) in a direction facing upward to the left, whereupon the flange **208g** of the window member **208** comes out of engagement with the V-shaped projection **206g** on the upper half's body **206**, permitting the window member **208** to be separated from the upper half's body **206** without breaking. If desired, a mark easily recognizable by the user or scrapper, as exemplified by PUSH, or an arrow designating the direction of depressing the window member **208** may be set off in the appropriate position and this helps provide a more positive way to designate the method of separating the two components.

[0246] **FIG. 20** shows a second example of the second embodiment of the fifth aspect of the invention, in which the window member **208** has the flange **208a** (**208e**) and the V-shaped recess **208c** (**208f**) provided alternately in an intermittent manner. This design eliminates the possibility for undercuts to form in the mold for shaping the window member **208** and the mold design is rendered simple enough to permit more economical fabrication of the window member **208**. Needless to say, if the design shown in **FIG. 20** is adopted, the recesses **206b** and **206f** in the upper half's body **206** around the opening **206a**, as well as the V-shaped projections **206d** and **206g** on the upper half's body **206** around the opening **206a** desirably have shapes corresponding to the flange **208a** (**208e**) and the V-shaped recess **208c** (**208f**) in order to permit the fabrication of seemingly more excellent magnetic tape cassettes (having better external appearance). It should be noted here that the V-shape suffices to be provided in at least one position and it need not be provided across the entire width of the window.

[0247] Described above is how the transparent window of the magnetic cassette case according to the second example

of the second embodiment of the fifth aspect of the invention is constructed. Unlike the prior art window which is fabricated by merely fitting the window member into the opening in the upper half's body and later welding them together, the areas in which the window member is joined to the upper half's body around the opening in it are formed to have an inclined V-shape in cross section, so the two components can be assembled without welding and the window member once fitted into the upper half's body is substantially immobile. The resulting upper half is not only adequately air-tight, it also has sufficient strength against external forces.

[0248] In order to separate the window member from the upper half's body when the magnetic tape cassette is discarded after use, one may push the window member from the inside (from below) upward at an angle, whereupon it can be separated from the opening in the upper half's body without breaking.

[0249] Described above are the basic features of the magnetic tape cassette according to the second embodiment of the fifth aspect of the invention.

[0250] We now describe a shaped resin article according to the sixth aspect of the invention with reference to FIGS. 21-28.

[0251] On the pages that follow, the shaped resin article according to the sixth aspect of the invention is described in detail by reference to a typical example, i.e., a magnetic tape cassette with a transparent residual tape check window that is integrated as an easily separable component. Needless to say, this is not the sole example of the invention.

[0252] FIG. 21 shows an example of the magnetic tape cassette according to the sixth aspect of the invention. As shown, the magnetic tape cassette generally indicated by 230 comprises an upper half 231 and a lower half 232 that combine to form a housing (cassette case). A slider 233 is fitted on the lower surface of the lower half 232 and a lid 234 is provided at the front face of the cassette (closer to the viewer of FIG. 21). Again, those parts of the magnetic tape cassette which are not shown in FIG. 21 are identical to the corresponding parts of the magnetic tape cassette shown in FIG. 1 and, hence, will not be described below in detail.

[0253] The housing of the magnetic tape cassette 230 contains a length of magnetic tape wound around a pair of take-up hubs. The user of the magnetic tape cassette 230 may occasionally find it necessary to check the residual amount of tape after unloading it from the deck (not shown). To this end, a transparent window member 236 (hereunder referred to simply as a window 236) is provided in a window receiving portion (a window member receiving area) 237 of the upper half 231 in such a way that it can be easily separated for recovery.

[0254] In the example under consideration, in order to facilitate the separation for recovery of the window 236, opposed sides of the window receiving portion 237 of the upper half 231 are provided with lugs 238 (238a, 238b, 238c, 238d, . . .) for holding the window 238 between two rows of lugs, one being in the upper position and the other in the lower position, on each side. To clarify the layout and shape of the lugs 238, sections of FIG. 21 are taken along lines III-III and IV-IV and shown in FIGS. 22 and 23, respectively.

[0255] As shown in FIG. 22, two vertically offset lugs 238a and 238b are provided on the opposed sides 237a and 237b, respectively, of the window receiving portion 237 of the upper half 231 such that the window 236 is held between the upper lug 238a and the lower lug 238b. Lugs 238c and 238d are provided in a similar way so that the window 236 is held between the upper lug 238c and the lower lug 238d.

[0256] As shown in FIG. 23, the lugs 238a, 238d, . . . which are provided on the side 237a of the window receiving portion 237 of the upper half 231 are vertically offset such that the window 236 is held between the upper and lower rows of lugs.

[0257] FIG. 24 is a perspective view showing enlarged the area in the neighborhood of the lugs 238b and 238c in the window receiving portion 237 of the upper half 231 shown in FIG. 21. As FIG. 24 shows, in order to ensure that the window 236 can be inserted between vertically offset lugs, the lugs 238b, 238c, . . . are provided on the side 237b of the window receiving portion 237 as they are spaced apart by a distance of d which is equal to the thickness of the window 236.

[0258] FIG. 25 shows the window 236 as it has been integrated into the window receiving portion 237 of FIG. 24. As shown, the window 236 with thickness is inserted between the lugs 238b, 238c, . . . so that it is installed in the upper half 231. If the distance d between the lugs 238b and 238c is adjusted to be a bit smaller than the thickness of the window 236, the latter is firmly secured to the upper half 231 and will not come off under small impact.

[0259] The shape of the window 236 is not limited to a simple rectangular plate. It is preferably a combination of two different sized rectangles as shown in FIG. 26 so that any two opposed sides have different lengths. If this design is adopted, the window receiving portion 237 should naturally have a shape corresponding to the shape of the window 236. To install the window 236 of the above-described shape, it is slid into the window receiving portion 237 of the upper half 231 by first pushing its shorter side in the direction indicated by the arrow A in FIG. 27.

[0260] To uncouple the window 236 from the upper half 231, one may simply push the other shorter side of the window 236 in the direction indicated by the arrow B in FIG. 27, whereupon the window 236 is easily separated for recovery from the upper half 231.

[0261] The window 236 may have a uniform thickness throughout as shown in FIG. 26. Alternatively, its thickness may be somewhat larger than d which represents the gap between an upper lug and a lower lug (see FIG. 24) and, as shown in FIG. 28, shallow recesses 236a, 236b, . . . may be provided in those areas of the window 236 which correspond to the respective lugs 238. Given this design, the recesses 236a, . . . come into firm engagement with the lugs 238 and the window 236 will not be displaced laterally but can be fixed more positively to the upper half 236.

[0262] The shape of the window 236 is by no means limited to the combination of two different sized rectangles. The only requirement is that the side of the window which is first pushed into the window receiving portion 237 of the upper half 231 (in the direction of the arrow A in FIG. 27) should be longer than the opposite side (which is indicated by the arrow B) and the window 236 may be trapezoidal in

shape as long as this requirement is met. In other words, the window 236 may of any shape as long as the window, being slid into the window receiving portion 237, does not pass through but stops in a predetermined position. Therefore, if the lugs 238 and the recesses (236a, . . .) are designed to provide an engagement of reasonable strength, the shape of the window 216 may be a simple rectangle.

[0263] The window receiving portion 237 need not have such a shape that it extends from one open end of the upper half 231 to the other end in the longitudinal direction; if desired, the end of the window receiving portion 237 indicated by the arrow B in FIG. 27 may be closed rather than open. In this case, the window can be separated for recovery from the upper half 231 by simply putting a finger on the window and pushing it in a direction in which it comes off.

[0264] According to the example described above, the window can be easily installed on and uncoupled from the upper half of the magnetic tape cassette, thus permitting easy separation for recovery of the housing and the window that are made of dissimilar materials.

[0265] The foregoing description is directed to the separation for recovery of the window from the upper half of the magnetic tape cassette. By applying the same concept to shaped resin articles that are composed of parts made of dissimilar materials, such parts can be easily separated for recovery and can easily be recycled by processing at the conventional facilities.

[0266] Described above are the basic features of the sixth aspect of the invention.

[0267] We next describe a magnetic tape cassette according to a third embodiment of the fifth aspect of the invention.

[0268] Again, the magnetic tape cassette according to the third embodiment of the fifth aspect of the invention has basically the same structure as the one shown in FIG. 1, except for the structure of the transparent window in the upper half and the mechanism for installing it. Therefore, on the following pages, only the structure and installing mechanism will be described in detail and the other parts will not be discussed.

[0269] FIG. 29 is a perspective view showing the upper half of a magnetic tape cassette according to an example of the third embodiment of the fifth aspect of the invention; FIG. 30 is section V-V of FIG. 29; FIG. 31 is a side view of the window member shown in FIG. 30; and FIG. 32 is a perspective view of the window member of FIG. 31 as it is seen from the bottom. Obviously, the transparent window in the upper half generally indicated by 250 in FIGS. 29 and 30 is provided in the body 256 of the upper half 250 and consists of two circular openings 256a formed as windows and two circular window members 258 that are made of a transparent resin and fitted in the openings 256a.

[0270] Fitted in the openings 256a in the upper half's body 256 are the window members 258 that have the shapes shown in FIGS. 31 and 32. Each of the window members 258 under consideration has a threaded portion 260 formed on the circumference of the part which is to be fitted into the opening 256a in the upper half's body 256. The opening 256a in the upper half's body 256 has an engaging portion 262 that comes into engagement with the threaded portion 260 on the circumference of the window member 258. The

engaging portion 262 may be threads of the same pitch as the threaded portion 260 of the window member 258. Alternatively, it may be a projection in pin form which, when installing the window member, can pass through a gap 264 in the threaded portion 260; an installing mechanism of this design is a well-known bayonet structure which permits the window member 258 to be installed and uncoupled in an easy way.

[0271] In order to ensure that the installed window member 258 is firmly secured to keep the upper half air-tight, a flange 266 is desirably provided on top of the window member 258. In this case, a step is desirably provided on the inner surface of the opening 256a in the upper half's body 256 to ensure that the window member 258 will not project from the latter. It is also desirable to provide a groove 268 in the bottom of the window member 258 so that a screw driver or other tool is put into the groove and helps rotate the window member 258 to be properly fitted in the upper half's body 256.

[0272] The groove 268 is also used when the window member 258 is separated for recovery from the upper half's body 256 of the magnetic tape cassette after it has been used and discarded. In order to ensure that the window member 258 will not be inadvertently separated from the upper half's body 256 while the magnetic tape cassette is in service, the groove 268 is desirably provided in the bottom of the window member 258. The groove 268 may be marked with a graduation for indicating the residual amount of tape. On the other hand, if it is undesirable that not only the residual amount of tape but also the groove 268 is visible while the user is looking at the interior of the magnetic tape cassette, the groove 268 may be replaced by two holes on the circumference of the window member 258.

[0273] According to the example described above, there is provided a magnetic tape cassette with a transparent window which, when discarded after use, permits easy and safe separation between the upper half's body and the window member so that they can be recovered and recycled as feeds for additional products.

[0274] FIG. 33A is a perspective view of a window member which is the major part of a transparent window in a magnetic tape cassette according to another example of the third embodiment of the fifth aspect of the invention; and FIG. 33B is a side view of the same window member. FIG. 34 is a partial perspective view of the opening in the upper half into which the window member shown in FIGS. 33A and 33B is to be fitted, and FIG. 35 illustrates how the window member according to the example shown in FIGS. 33A and 33B engages the inner circumference of the opening in the upper half.

[0275] The method the second example under consideration adopts to engage the transparent window in the magnetic tape cassette is different from the method adopted by the first example in that an engaging portion 274 consisting of an interrupted helical thread is formed on the inner circumference of the opening in the upper half whereas engaging ribs 272 are formed on the outer circumference of the window member 270. As in the first example, the window member 270 as the major part of the transparent window in the magnetic tape cassette is easy to install on and separate from the upper half.

[0276] Thus, according to the second example described above, there is provided a magnetic tape cassette with a

transparent window which, when discarded after use, permits easy and safe separation between the upper half's body and the window member so that they can be recovered and recycled as feeds for additional products.

[0277] Described above are the basic features of the third embodiment of the fifth aspect of the invention.

[0278] We next describe a magnetic tape cassette according to the second aspect of the invention and the process for its fabrication with reference to FIGS. 36-42.

[0279] Again, the magnetic tape cassette according to the second aspect of the invention has basically the same structure as the one shown in FIG. 1, except for the structure of the transparent window in the upper half and the mechanism for installing it. Therefore, on the following pages, only the structure and installing mechanism will be described in detail and the other parts will not be discussed.

[0280] FIG. 36 is a perspective view showing the upper half of a magnetic tape cassette according to an embodiment of the second aspect of the invention; FIG. 37 is section VI-VI of FIG. 36; and FIGS. 38 and 39 are sections of the upper half and the window member that are taken through FIG. 37 along line VII-VII. The transparent window in the upper half generally indicated by 306 in FIGS. 36, 37 and 39 consists of an opening 300a formed as a window in the upper half 300 and a window member 306 that is made of a transparent resin and fitted in the opening 300a.

[0281] As shown in FIG. 38, the opening 300a is formed in the upper half (or the upper half's body) 300 such that it has an upper window frame 300b which is thick enough to provide adequate rigidity and a lower window frame 300d which is thin enough to be capable of elastic deformation; since a groove 300c into which the window member 306 is fitted is formed between the upper window frame 300b and the lower window frame 300d, the upper half (or the upper half's body) 300 on either side of the opening 300a has a generally U-shaped cross-section. In the embodiment shown in FIG. 38, the lower window frame 300d has a uniform thickness but it may be formed thin in selected areas to ensure that it will easily undergo elastic deformation.

[0282] The window member 306 to be fitted into the opening 300a in the upper half 300 may have an identical shape to the groove 300c in the inner circumference of the opening 300a or it may be somewhat smaller so that it can be easily inserted into the groove. The thickness of the window member 306 may be equal to the width of the groove 300c or it may be somewhat smaller so that it can be easily inserted into the groove. The window member 306 has ridges 306a in such positions that they contact the lower window frame 300d when it has been inserted into the groove 300c.

[0283] In order to install the separable transparent window of the magnetic tape cassette according to the first embodiment of the second aspect of the invention, the following method may be employed. The first step of the process of fitting the transparent window member 306 in the upper half 300 involves inserting the window member 306 into the groove 300c in the upper half 300 so that the two are joined temporarily. Since the ridges 306a on the window member 306 are provided in the positions where they contact the lower window frame 300d of the upper half 300, the inserted window member 306 causes the lower window frame 300d

to deform elastically so that it is retained to the upper half 300 as the two members are joined temporarily (see FIG. 40).

[0284] In the second step, the temporary joint where the lower window frame 300d has undergone elastic deformation to retain the window member 306 is subjected to ultrasonic or thermal welding. However, if the upper half 300 and the window member 306 are made of materials that have no compatibility or have only small compatibility with each other, as in the case where the upper half 300 is made of an ABS resin and the window member 306 a transparent PS resin, ultrasonic or thermal welding does not cause fusion to occur between the upper half 300 and the window member 306 (particularly the ridges 306a); instead, the joining surfaces of the upper half 300 and the window member 306 (particularly the ridges 306a) will only be depressed to deform as shown in FIG. 41.

[0285] Briefly, by means of ultrasonic or thermal welding, the elastic deformation of the lower window frame 300d is eliminated but the window member 306 will not be fused to the upper half 300 and the two members contact each other leaving no clearances therebetween so that they are incapable of relative movements (the window member 306 is fixed in position by being held between the upper and lower window frames 300b and 300d). The thus formed transparent window of the tape magnetic tape cassette is just the same as the transparent window of the prior art and hence can be used without any difficulties. Note that the ridges 306a may be provided on the upper half 300 rather than on the window member 306.

[0286] The thus fabricated cassette case is then put to service and discarded. In this case, the window member 306 may be separated from the upper half 300 in the following manner so that the two parts can be recycled as feeds for additional production. Since the window member 306 is not fused to the upper half 300, the user may push it hard from above, whereupon the lower window frame 300d of the upper half 300 deforms and the window member 306 can be easily recovered. Even if the lower window frame 300d deforms only insufficiently and the window member 306 breaks while it is pushed out of engagement with the lower window frame 300d, the broken window member 306 can be easily recovered from the groove 300c in the upper half 300 since the two members are not fused together.

[0287] Since the window member 306 and the upper half 300 are not fused to each other, no part of the window member 306 will remain adhering to the upper half 300 or vice versa; the window member 306 can be completely separated from the upper half 300 and the two parts can be recycled without suffering a drop in the purity as feeds for additional production.

[0288] Another benefit is obtained in the operation of separating the window member 306 from the upper half 300. Since the two components are not fused together, the window member 306 can be easily separated from the upper half 300 of the cassette case. Should the window member 306 break, it can be easily recovered from the groove 300c in the upper half 300 and this contributes safety to the separating operation.

[0289] FIG. 42 is a perspective view of a magnetic tape cassette according to another embodiment of the second

aspect of the invention as it is sectioned through the transparent window in the upper half. The difference from the first embodiment is that the upper window frame **300b** which is formed around the opening **306a** in the upper half **300** and the lower window frame **300d** which is thin enough to deform elastically, both being provided to hold and fix the window member in position, do not form continuous shapes but are rather formed in a plurality of discrete areas.

[0290] The magnetic tape cassette according to the second embodiment brings about essentially the same advantage as the tape cassette according to the first embodiment.

[0291] The second aspect of the invention also relates to the process for producing the magnetic tape cassettes according to the two embodiments described above. The process involves the following steps: first, the window member **306** and the upper half **300** serving as the base are molded; the window member **306** is molded from a material that has no compatibility or has an extremely low degree of compatibility with the material of which the upper half **300** is made whereas the upper half **300** is molded in such a way that at least part of the area around the opening **300a** has the adequately rigid upper window frame **300b**, the elastically deformable lower window frame **300d** and the groove **300c** formed between the two window frames to provide a temporary fitting area into which the window member **306** can be inserted; the upper frame **300** and the window member **306** are also molded in such a way that the upper window frame **300b**, the lower window frame **300d** or the window member **306** has ribs in positions where either window frame contacts the window member **306** (in the illustrated case, the ribs **306a** are formed on the window member **306**); in the second step, the window member **306** is inserted into the groove **300c**, whereupon the lower window frame **300d** deforms elastically to establish temporary joint with the ribs **306a**; thereafter, ultrasonic wave or heat is applied to the temporary joint.

[0292] As a result, the ribs **306a** joining temporarily to the lower window frame **300d** collapse under the ultrasonic or thermal action so that the window member **306** is securely fastened in the groove **300c** between the upper and lower window frames **300b** and **300d** formed in the upper half **300** around the opening **300a**. Needless to say, the window member **306** can be completely separated from the upper half **300** in a simple and safe manner, with no part of it adhering to the latter. Thus, the process for producing the magnetic tape cassette according to the second aspect of the invention is quite effective.

[0293] Described above are the basic features of the second aspect of the invention.

[0294] We next describe a magnetic tape cassette according to the third aspect of the invention and the process for its fabrication with reference to **FIGS. 43-46**.

[0295] Again, the magnetic tape cassette according to the third aspect of the invention has basically the same structure as the one shown in **FIG. 1**, except for the structure of the transparent window in the upper half and the mechanism for installing it. Therefore, on the following pages, only the structure and installing mechanism will be described in detail and the other parts will not be discussed.

[0296] **FIG. 43** is a perspective view showing the upper half of a magnetic tape cassette according to an embodiment

of the third aspect of the invention as it is sectioned in a longitudinal direction; and **FIG. 44** is a partial enlarged section of the upper half shown in **FIG. 43**. As is clear from these figures, the transparent window in the upper half generally indicated by **330** consists of an opening **330a** formed in the upper half **330** and a window member **336** that is made of a transparent resin and fitted in the opening **330a**.

[0297] As shown in **FIG. 44**, the body of the upper half **330** has the opening **330a** and recesses **330b** and **330c** are formed in the inner surfaces on both sides of the opening **330a**. The two recesses are interconnected by an edge portion **330d**. In the embodiment shown in **FIG. 44**, the edge portion **330d** formed as the bridge between the two recesses has a cross-sectional shape resembling a square block; however, as will be described later, the square is not the sole example that can be adopted in the invention.

[0298] The edge portion **330d** may be provided on the perimeter of the opening **330a** either throughout (continuously) or in selected areas (intermittently). For the reasons that will be set forth below, the edge portion **330d** shown in **FIG. 44** is desirably provided on the entire perimeter of the opening **330a**.

[0299] We next describe the method of forming the transparent window.

[0300] **FIGS. 45A and 45B** illustrate the process for making the transparent window according to the embodiment shown in **FIG. 44**. A die assembly for molding the upper half's body **330** having the transparent window has an upper die **360** and a lower die **362** that define the general shape of the upper half's body **330**. The upper die **360** and the lower die **362** are of well-known types that can be used to mold a predetermined shape. Since the two dies are identical to those of the prior art, they need not be described herein and instead only portions that are relevant to the process for making the transparent window will be described below.

[0301] The die assembly consisting of the upper die **360** and the lower die **362** has two cores (or cavities) in the area where the opening **330a** is made to receive the transparent window being fitted in; the first core **364** is provided in the upper die **360** to form the recess **330b** in the front surface and the second core **366** is provided in the lower die **362** to form the recess **330c** in the back surface and the edge portion **330d** bridging the two recesses. The first core **364** and the second core **366** are so designed that they can be pushed into or withdrawn from the upper die **360** and the lower die **362**, respectively.

[0302] **FIG. 45A** shows the step of molding the upper half's body **330** with the die assembly described above. As shown, the first core **364** and the second core **366** are allowed to project from the upper die **360** and the lower die **362**, respectively, until the distal ends of the two cores are brought into intimate contact with each other; as a result, a space or a cavity **368** is defined by the upper die **360**, the lower die **362**, the first core **364** and the second core **366**; a resin such as an ABS resin is injected into the cavity **368** to mold the upper half's body **330** together with the recesses **330b** and **330c** on both sides of the opening **330a** as well as the edge portion **330d** bridging those recesses.

[0303] **FIG. 45B** shows the step of molding the transparent window member **336** in the opening **330a** in the upper

half's body 330 using the die assembly described in the preceding paragraph which consists of the upper die 360 and the lower die 362, as well as the first core 364 and the second core 366. As shown, a space or a cavity 370 is defined by the molded upper half's body 330 and the die assembly having the first core 364 and the second core 366 retracted into the upper die 360 and the lower die 362, respectively, and a transparent resin such as a PS resin that has no compatibility or has an extremely low degree of compatibility with the resin such as ABS resin that has been injected to mold the upper half's body 330 is injected into the cavity 370 so that the transparent window member 336 is molded and fitted as an integral part of the upper half's body 330.

[0304] FIG. 46 shows a transparent window according to another embodiment of the third aspect of the invention and this window can be molded in entirely the same manner as in the first embodiment by injecting a transparent resin into a cavity 372. Hence, there is no need to give a detailed description of this second embodiment.

[0305] The third aspect of the invention also relates to the process for producing the magnetic tape cassettes according to the above embodiments. The process involves the following steps: the first step is providing the die assembly for molding the upper half's body 330 which comprises the upper die 360 and the lower die 362, as well as the first core 364 and the second core 366 for making the opening 330a in the upper half's body 330, the first core 364 being capable of sliding into the die cavity from the front surface of the upper half's body and the second core 366 being capable of sliding into the die cavity from the back surface of the upper half's body 330 and having on opposite ends two recesses 366a that are used to provide ridges 330d for establishing engagement between the window member 336 and the opening 330a in the upper half's body 330; in the second step, the first core 364 and the second core 366 in the die assembly are brought into intimate contact with each other; then, an upper half's body forming resin material is injected to mold the upper half's body 330 with the opening 330a in it; thereafter, the first core 364 and the second core 366 are spaced apart and a transparent window member forming resin material that has no compatibility or has an extremely low degree of compatibility with the upper half's body forming resin material is injected into the resulting space (cavity) to mold the window member 336 as an integral part of the upper half's body 330. This process for producing the magnetic tape cassette according to the third aspect of the invention is quite effective.

[0306] When the magnetic tape cassette employing the upper half's body 330 described above is discarded after use, one may find it necessary to disassemble the cassette case for recycling purposes. In this case, one may simply detach the upper half 330 and press the window member 336 by applying a strong force to its underside. The upper half's body 330 and the window member 336 are not fused to each other in the first embodiment shown in FIG. 44, so if the window member 336 is depressed with great force from below, the edge portion 330d around the opening 330a will undergo plastic-deformation or the edge of the window member 336 may break and come off; in either case, the window member 336 can be easily separated from the upper half's body 330.

[0307] In particular, if the upper half's body 330 and the window member 336 are positioned in such a way that the

lower end of the edge portion 330d is in close proximity with the upper end of the annular portion 336a and if both ends are sharp pointed, an applied stress will sufficiently concentrate that the annular portion 336a of the window member 336 will simply break and come off with a comparatively small force. In this case, the edge portion 330d is desirably provided on the entire perimeter of the opening 330a so that the annular portion 336a will break and come off along the entire perimeter of the opening 330a.

[0308] The window member according to the embodiment shown in FIG. 46 is so designed that the edge portion 330e of the upper half's body 330 around the opening 330a can deform more easily when the window member 336 is depressed from below with strong force. In the embodiment under consideration, the edge portion 330e has such a cross-sectional shape that it projects as a triangular block with a plane inclined into the opening 330a. If the window member 336 is depressed from below, the inclined plane deforms elastically; if it is depressed with a greater force, the inclined plane starts to undergo plastic deformation and the annular portion 336a of the window member 336 will come off, whereupon the window member 336 can be easily separated from the upper half's body 330. Hence, in the embodiment shown in FIG. 46, the edge portion 330e is desirably provided in interrupted positions on the perimeter of the opening 330a.

[0309] The transparent window in the magnetic tape cassette according to the two embodiments of the third aspect of the invention are fabricated as described above. Since the upper half's body 330 serving as the base and the window member 336 are molded monolithically of two resins that have no compatibility with each other (or those which have little compatibility), the upper half is sufficiently air-tight to ensure satisfactory dust prevention. In addition, it is only external pressure and impact that are exerted on the tape cassette during manual handling as in the case of carrying, storage and loading on the record/reproduce apparatus; therefore, the tape cassette according to the third aspect of the invention has no strength problems at all if the edge portion 330d or 330e is designed to have sufficient strength to withstand internal impact without breaking or coming off.

[0310] Described above are the basic features of the third aspect of the invention.

[0311] We now describe the method for multi-color molding of resin products according to the fourth aspect of the invention, as well as the magnetic tape cassette which is the resin product molded by the method with reference to FIGS. 47-54.

[0312] In the following description, a magnetic tape cassette is assumed as a typical example and particular reference is made to the method for molding an upper half which constitutes the housing of the magnetic tape cassette and a transparent window provided in the upper half as an aid for checking the residual amount of magnetic tape. It should, however, be noted that these are not the sole examples of the invention. Again, the magnetic tape cassette as the typical example has basically the same structure as the one shown in FIG. 1, except for the structure of the transparent window in the upper half and the mechanism for installing it. Therefore, on the following pages, only the structure and installing mechanism will be described in detail and the other parts will not be discussed.

[0313] FIG. 47 is a plan view showing the upper half of the magnetic tape cassette according to the example under consideration and the transparent window provided in this upper half as an aid for checking the residual amount of magnetic tape. As shown in FIG. 47, the upper half indicated by 410 is provided with the transparent window 412 (hereunder referred to simply as the window 412) as an aid for checking the residual amount of magnetic tape within the housing. The window 412 has lugs 412a, 412b, . . . on the perimeter which are to fit the predetermined shapes provided on the upper half 410 as shown in FIG. 48 which is section VIII-VIII of FIG. 47. As shown, the lugs 412a and 412b of the window 412 alternate both horizontally and vertically with the predetermined shapes provided in the end portion 411 of the window opening in the upper half 410 such that an upper lug fits an adjacent lower predetermined shape whereas a lower lug fits an adjacent upper predetermined shape.

[0314] The fitting combination of the upper half 410 and the window 412 is shown more clearly in FIG. 49 which is a partial enlarged perspective view of the window 412 as it is fitted in the upper half 410. As shown, the lug 412a of the window 412 is fitted in a recess 411a formed in the end portion 411 of the window opening in the upper half 410 whereas the lug 412b is fitted in another recess 411b also formed in the end portion 411 of the window opening in the upper half 410. The recess 411a has a bottom on which the lug 412a rests and it is open at the top. On the other hand, the recess 411b has no bottom; instead, it is closed at the top as if it were fitted with a lid and the lug 412b is fitted into this recess 411b.

[0315] In the example under consideration, the upper half 410 and the window 412 are molded by core-backing two-color molding and the two elements can be assembled together in such a way that the window 412 is easily separable from the upper half 410.

[0316] To this end, the upper half 410 is so shaped that the end portion 411 of the window opening is indented as shown in FIG. 50. Specifically, recesses 411a-411d into which lugs 412a-412d of the window 412 are to be fitted and recesses 411a'-411d' for molding the lugs 412a-412d are formed along the end portion 411 of the window opening.

[0317] The recesses 411a-411d into which the lugs 412a-412d are to be fitted are so formed that adjacent ones are inverted with respect to the window 412 and the upper half 410. Stated specifically, the recess 411a has the bottom 413 whereas the adjacent recess 411c has no bottom but has the lid-like top 415.

[0318] The bottom 413 is so formed that it extends a little inward of the window opening along its end portion 411. This is in order to ensure that when the window 412 is installed in the upper half 410, the edge of the window 412 will ride over the bottom 413 by a small amount, and thereby eliminate any gap to provide more effective dust prevention.

[0319] FIG. 51 is a perspective view showing enlarged a part of the window 412. As shown, the window 412 has lugs 412a-412d that help it come into engagement with the upper half 410. The lugs 412a-412d are formed in the same thickness as the window 412 and in order to provide ease in fitting with the recesses 411a-411d in the upper half 410, those lugs are rounded at corners. Alternatively, the lugs

412a-412d may be provided with a specified amount of taper in order to assure positive fitting with the recesses 411a-411d in the upper half 410.

[0320] FIG. 52 is a partial perspective view showing enlarged the upper half 410 and the window 412 that have been molded simultaneously. In the embodiment under consideration, the upper half 410 and the window 412 are molded of incompatible and non-adherent materials using the same die assembly; then the window 412 is separated from the upper half 410 and turned upside down so that it can be replaced in the upper half 410. To this end, the design shown in FIG. 32 is adopted; in order to mold the lug 412a of the window 412, the upper half 410 is provided with a recess 411a' in a position diametric to the recess 411a across the window opening; in order to mold the lug 412b, a recess 411b' is provided in a position diametric to the recess 411b; in order to mold the lug 412c, a recess 411c' is provided in a position diametric to the recess 411c; and in order to mold the lug 412d, a recess 411d' is provided adjacent the recess 411d.

[0321] FIGS. 53A-53B show a die assembly that may be used to mold the upper half 410 and the window 412 that are shown in FIG. 52. FIGS. 53A and 53B are sections of the die assembly that correspond to section IX-IX of FIG. 52. As shown in FIG. 53A, the die assembly for molding the upper half 410 and the window 412 which is generally indicated by 420 consists mainly of an upper die 422, a lower die 424 and a movable core 426. The first step in the molding process is for molding the upper half 410 by injecting a molten resin into a space (cavity) 430 defined by the upper die 422, the lower die 424 and the movable core 426.

[0322] In the next step, the movable core 426 is lowered down by a distance equal to the thickness of the window 412 and into the resulting space 432, a resin that is neither compatible with nor adherent to the resin of which the upper half was molded is injected to mold the window 412.

[0323] An outline of the movable core 426 is shown in perspective in FIG. 53C. The movable core 426 has lugs 426a, . . . for molding the lugs 412a, . . . of the window 412. The movable core 426 shown in FIGS. 53A and 53B is section X-X of FIG. 53C.

[0324] By two-color molding with the same die assembly 420, the upper half 410 and the window 412 can be molded at substantially the same timing (see FIG. 52). Since the upper half 410 and the window 412 are molded of incompatible materials, the former can be easily separated from the window (by lifting it up in FIG. 52).

[0325] The window 412 is then turned upside down and replaced in the upper half 410 as shown in FIG. 54. The lug 412a of the window molded in the recess 411a' of the upper half 410 is fitted into the opposite recess 411a in the upper half 410. Similarly, the lug 412b of the window 412 molded in the recess 411b' is fitted into the opposite recess 411b; the lug 412c of the window 412 molded in the recess 411c' is fitted into the opposite recess 411c. The lug 412d of the window 412 molded in the recess 411d' is fitted into the adjacent recess 411d. The end portions of the window 412 side over the bottom 413, a small extension of the upper half 410, so that the gaps around the window 412 (where the lugs 412a, . . . are not provided) are closed to provide enhanced dust prevention.

[0326] The magnetic tape cassette according to the embodiment discussed above can be produced by applying the process for producing resin products according to the fourth aspect of the invention. First, resin parts including the upper half (its body) **410** and the window (its member) **412** are molded in multiple colors by means of the single die assembly **420** using at least two incompatible, non-adherent materials. After demolding the upper half **410** and the window member **412**, the window **412** is turned upside down and replaced in the upper half **410**.

[0327] Thus, in the embodiment under consideration, the upper half and the window are molded in two colors by means of the same die assembly using incompatible materials, or those non-adherent materials which have distant values for compatibilization parameter; after the molding, the window is separated from the upper half, turned upside down and replaced in the upper half. This provides ease not only in installing the window in the upper half but also separating the two parts as required for recycling.

[0328] In **FIGS. 52 and 54**, the fitting of the lugs **412** of the window **412** into the recesses **411**, for example, the fitting of the lug **412b** into the recess **411b** is so shown that a gap exists between the top of the lug **412b** and the inner surfaces of the recess **411b**. This is an exaggeration intended to clarify the state of coupling between the lug **412b** and the recess **411b**. In practice, as shown in **FIG. 48** (sectional view) or **FIG. 49** (perspective view), there are substantially no gaps between the set of lugs **412a, . . .** on the window **412** and the set of recesses **411a, . . .** in the upper half **410** and the former fit so snugly into the latter that there is no possibility for the window **412** to rattle when the magnetic tape cassette is in service.

[0329] Described above is not the only method for coupling the window to the upper half and the shapes of these parts also are not limited to the examples described above. Other suitable methods can of course be employed to bring the window into engagement with the upper half.

[0330] Thus, in the embodiment described above, the window and the upper half are molded of incompatible materials (in two colors or layers) by the core backing process; after the molding, the window is separated from the upper half, turned upside down and replaced in the upper half so that the former is brought into engagement with the latter by means of fitting between the lugs and recesses formed in the shaped article or some other suitable engaging means; as a result, the window, the upper half and various other parts of the magnetic tape cassette can easily be recovered as separate entities.

[0331] Described above are the basic features of the fourth aspect of the invention.

[0332] We next describe the magnetic tape cassette according to the seventh aspect of the invention with reference to **FIGS. 55-58**.

[0333] Again, the magnetic tape cassette according to the seventh aspect of the invention has basically the same structure as the one shown in **FIG. 1**, except for the structure of the transparent window in the upper half and the mechanism for installing it. Therefore, on the following pages, only the structure and installing mechanism will be described in detail and the other parts will not be discussed.

[0334] **FIG. 55** is an enlarged perspective view showing, with part taken away, a manipulating engaging portion provided in the upper half of a magnetic tape cassette according to an example of the seventh aspect of the invention. **FIG. 56** is a longitudinal section of the upper half generally indicated by **116** in **FIG. 55**. As is clear from **FIGS. 55 and 56**, the transparent window in the upper half **116** is such that an opening **156a** is formed in the upper half's body **156** along its entire length and a window member **158** made of a transparent resin is fitted along the entire length of the upper half's body **156** in such a way as to cover the whole area of the opening **156a**.

[0335] The upper half's body **156** has edge portions **156b** that extend into the opening **156a**. By installing the window member **158** such that the edge portions **158** formed on its opposed lateral sides rest on the edge portions **156b**, the upper half's body **156** and the window member **158** are brought into intimate contact with each other to maintain the air-tightness of the upper half **116**. In addition, the window member **158** will not break or come off even if external pressure and impact are exerted on the magnetic tape cassette during manual handling as in the case of carrying, storage and loading on the record/reproduce apparatus.

[0336] Either end of the window member **158** extends to the associated end of the opening **156a** running along the entire length of the upper half's body **156** and ends with an engaging member **160** bent at right angles. A manipulating engaging pawl **160a** provided at the distal end of the engaging member **160** is fitted into engagement with an engaging groove **156c** provided at either end of the upper half's body **156** in its longitudinal direction. Provided further downward of the engaging groove **156c** is a disengagement groove **156d** into which a tool is inserted in order to bring the manipulating engaging pawl **160a** out of engagement with the engaging groove **156c**.

[0337] In order to ensure that the window member **158** makes snug fit within the opening **156a** in the upper half's body **156**, the window member **158** is desirably shaped to bent slightly upward whereas the engaging members **160** on the window member **158** are shaped to bent slightly inward. Having these shapes, the window member **158** deforms of its own elasticity and the edge portions **158a** of the window member **158** come into intimate contact with the edge portions **156b** of the upper half's body **156** on the opposed sides of the opening **156a**, whereupon the engaging members **160** are urged to be positively fitted into the engaging grooves **156c** so that they will not come off easily.

[0338] The magnetic tape cassette according to the example under consideration has the structure described above. When it is in service, the edge portions **156b** of the upper half's body **156** on the opposed sides of the opening **156a** remain in intimate contact with the edge portions **158a** of the window member **158** and no problems are encountered with respect to air-tightness and strength. If the magnetic tape cassette is discarded after use, a tool may be inserted into the disengagement groove **156d** in the upper half's body **156** and pushed inward such that the manipulating engaging pawl **160a** of the engaging member **160** provided on the window member **158** is dislodged from the engaging groove **156c**; as a result, the window member **158** can be easily separated from the upper half's body **156** without letting any foreign material stick to either part.

[0339] In the example shown in **FIGS. 55 and 56**, the disengagement grooves **156d** provided in the upper half's body **156** are of a sufficient length that a tool can be inserted into these grooves for canceling the engagement with the manipulating engaging pawls **160a**. Of course, the disengagement grooves **156d** may be of such a shape that they are continuous from the top to the bottom of either end face of the upper half.

[0340] **FIG. 57** is a perspective view of a magnetic tape cassette with a transparent window according to another example of the seventh aspect of the invention, and **FIGS. 58A and 58B** are sections taken along line XI-XI in **FIG. 57**. In the example under consideration, the window member **158** is not provided in the upper half's body **156** along its entire length; instead, it is possible to provide a transparent window of the same size as in the prior art. As shown specifically in **FIG. 57**, the transparent window in the upper half **116** is fabricated by first providing the upper half's body **156** with an opening **156a** of the same size as in the prior art and then fitting it with the window member **158** of the same size.

[0341] An edge portion **156b** of the same type as used in the first example is provided on the upper half's body **156** on the entire perimeter of the opening **156a** except in the area where a cutout **156e** is provided. The window member **158** has an edge portion **158a** of the same type as used in the first example, which rests on the edge portion **156b** when the window member **158** is fitted in the opening **156a**. As shown in **FIGS. 58A and 58B**, the window member **158** has on one lateral side (the left side) a retaining pawl **158b** which is so formed as to hold the edge portion **150b** of the upper half's body **156** in cooperation with the edge portion **158a**; by means of the retaining pawl **158b**, the edge portion **156b** is held in intimate contact with the edge portion **158a**.

[0342] In the center of the other side (the right side) of the window member **158**, there is provided an engaging member **162** which secures the window member **158** to the upper half's body **156**. The engaging member **162** is positioned within the cutout **156e** in the upper half's body **156** such that an engaging pawl **162a** at the distal end is brought into engagement with the underside of the upper half's body **156** to fix the window member **158** in position. The engaging member **162** also has a thin-walled, elastic spring portion **162b** which urges it to be positively brought into engagement with the underside of the upper half's body **156**.

[0343] In the example shown in **FIG. 58A**, both the retaining pawl **158b** of the window member **158** and the engaging pawl **162a** of the engaging member **162** project down below the upper half's body **156**. If this is not desirable for certain reasons such as the layout of magnetic tape within the cassette case, both the retaining pawl **158b** and the engaging pawl **162a** may be confined within the upper half's body **156** as shown in **FIG. 58B**. In this alternative case, the recess through which the engaging pawl **162a** is passed to establish engagement with the underside of the upper half's body **156** may itself be used as a disengagement groove **156f** by means of which the engaging pawl **162a** can be disengaged from the underside of the upper half's body **156**.

[0344] When the magnetic tape cassette according to the example shown in **FIGS. 57 and 58** is in service, the edge portion **156b** of the upper half's body **156** on the perimeter

of the opening **156a** remains in intimate contact with the edge portion **158a** of the window member **158** and the window member **158** has no problems at all with respect to air-tightness and strength.

[0345] If the magnetic tape cassette, whether it is of the example shown in **FIG. 58A** or **58B**, is discarded after use, a tool may be inserted into the manipulating engaging portion **156g** or **156h** from above the cassette case **156d** and the engaging pawl **162a** of the engaging member **162** is dislodged from the corresponding cutout of the opening **156a**; as a result, the window member **158** can be easily separated from the upper half's body **156** without letting any foreign material stick to or mingle with either part.

[0346] The seventh aspect of the invention is by no means limited to the foregoing examples and it is possible to use engaging pawls of other structures. Of course, the concept of this aspect can equally be applied to various types of transparent window that are provided in other models of magnetic tape cassette as an aid for visual check of the interior.

[0347] For instance, the foregoing examples are directed to the case where the window member **158** is brought into mechanical engagement with the upper half's body **156**; however, this is not the sole case of the invention and it can be implemented with other cases of engagement between the window member **158** and the upper half's body **156** such as where it is accomplished by thermal welding or through thermal fusion of two compatible resins.

[0348] Described above are the basic features of the seventh aspect of the invention.

[0349] We now describe a magnetic tape cassette according to the eighth aspect of the invention.

[0350] As already mentioned, the choice for resins that constitute individual parts (members) of the magnetic tape cassette has heretofore depended primarily on mechanical strength (including creep resistance), physical properties such as dimensional stability and heat resistance, and chemical properties such as corrosion resistance. In recent years, another important factor has been added to the list—the ease with which resins can be decomposed with naturally occurring microorganisms (called biodegradability, this factor is important when the magnetic tape cassette is disposed of by discarding).

[0351] The magnetic tape cassette (hereunder referred to simply as “cassette”) according to the eighth aspect of the invention is characterized by constituting various parts (members) of the cassette with resins having good “biodegradability”. In the following description of the eighth aspect of the invention, the term “upper” shall mean the side where the upper half is positioned and the term “lower” shall mean the side where the lower half is positioned.

[0352] The concept of the eighth aspect of the invention is applied to a magnetic tape cassette comprising magnetic tape and a housing in which the magnetic tape is placed rotatably; it is applicable to all models of the two-reel type magnetic tape cassettes in which a pair of tape reels having the magnetic tape wound around a pair of reel hubs are placed in specified positions such that the magnetic tape can be drawn out of the housing or that it is capable of running; alternatively, it can be applied to all models of the one-reel

type magnetic tape cassettes in which a single tape reel having the magnetic tape wound around a single reel hub is placed in a specified position such that the magnetic tape can be drawn out of the housing or that it is capable of running.

[0353] In the cassette according to the eighth aspect of the invention, the housing (cassette case) is a member that is principally composed of the upper half and the lower half and which additionally includes other parts to be installed in the upper or lower half, as well as the tape reel or reels around which the magnetic tape is wound and those parts which are used to hold or accommodate the part of the magnetic tape which has been unwound from the tape reel or reels. Other parts to be installed in the upper or lower half include the lid (front cover) and the slider which is slidably fitted on the underside of the lower half; these and other necessary components are combined with the upper and lower halves to make up the housing (cassette case).

[0354] A cassette according to an example of the eighth aspect of the invention is such that the window member to be fitted into at least one of the window openings in the upper half is made of a biodegradable resin. The biodegradable resin which forms the window member maintains comparable functions to the conventional resins during service but is thereafter decomposed by the action of naturally occurring microorganisms to be eventually converted to water and inorganic matter such as carbon dioxide; the biodegradability of such resins can be tested by the methods described in ISO 14851, ISO 14852 and ISO 14855.

[0355] ISO 14851 and ISO 14852 specify the biodegradability in an aerobic aqueous system; the rate of decomposition is determined from the consumption of oxygen (in ISO 14851) or from the evolution of carbon dioxide (in ISO 14852) and those resins which are decomposed by at least 60% within a maximum period of 6 months are regarded as applicable biodegradable resins. In ISO 14855, the rate of decomposition is determined from the evolution of carbon dioxide under composting conditions and those resins which are decomposed by at least 70% within a maximum period of 6 months are regarded as applicable biodegradable resins.

[0356] The biodegradable resins meeting those requirements can be classified as follows:

(1) Organism Produced Polymers

(a) poly(β -hydroxybutyric acid) (e.g. BIOGREEN of MITSUBISHI GAS CHEMICAL CO., INC.)

(b) poly(hydroxybutyrate-hydroxyvalerate) (e.g. BIOPOL of Japan Monsanto in an amount of up to about 30% as an additive (filler))

(2) Synthetic Polymers

(a) poly(lactic acid) (LACTY of Shimadzu Corp., RAYCIA of Mitsui Chemicals, Inc., and ECOPLAY of Cargill-Dow)

(b) polycaprolactone (PCL) (CELL GREEN P-H of DAICEL CHEMICAL INDUSTRIES, LTD. in an amount of up to about 30% as an additive (filler))

(3) Naturally Occurring Polymers

(a) cellulose acetate (e.g. CELL GREEN P-CA of DAICEL CHEMICAL INDUSTRIES, LTD.)

(b) starch+PCL (e.g. MATERBY of Nippon Synthetic Chemical Industry Co., Ltd. and NOBON of Chisso Corporation)

(c) modified starch (e.g. EVER CORN of Nippon Corn Starch Co., Ltd.)

[0357] Note that all polymers listed above can be used as additives (fillers).

[0358] In the eighth aspect of the invention, accelerators for microbial degradation may also be used. Exemplary accelerators for microbial degradation include master batches prepared by blending high concentrations of various starches including corn starch, potato starch, rice starch and their modified starches.

[0359] Biodegradable resins used to form the window member are preferably based on poly(lactic acid), more preferably in combination with poly(hydroxybutyrene) (PHB), polycaprolactone (PCL) or poly(butyrene succinate) (PBS). Particularly preferred is the combination of poly(lactic acid) with 1-60%, most preferably 20-30%, of poly(hydroxybutyrene) (PHB), polycaprolactone (PCL) or poly(butyrene succinate) (PBS) since this provides good melt flow characteristics during molding and the obtained window member is high in impact resistance, clarity and resistance to hydrolysis.

[0360] In the example under consideration, the window member can be produced by injection molding of one or more of the biodegradable resins listed above or a batch consisting of such biodegradable resins as a major ingredient and other necessary ingredients. The shape, size and other parameters of the window member may be chosen as appropriate for the magnetic tape cassette into which it is to be fitted.

[0361] The window member can be fitted into the window opening by various methods which include but are not limited to welding, mechanical fitting and snap fitting. If fitting is effected by welding, the use of the biodegradable resins has the advantage that the window member undergoing thermal recycling emits less heat which is no more than half the amount generated from all-purpose resins such as ABS resins.

[0362] Described above are the basic features of the eighth aspect of the invention.

[0363] We now describe a method for destructing and separating components made of dissimilar materials according to the ninth aspect of the invention with reference to **FIGS. 59-63**.

[0364] In the following description of the method for destructing and separating components made of dissimilar materials according to the ninth aspect of the invention, a magnetic tape cassette is taken as a typical example of a resin product made of dissimilar materials and detailed description is given below for the method which is intended to ensure that a transparent window provided in the cassette case (housing) in order to help check the residual amount of magnetic tape can be readily taken apart from the housing for recycling. Needless to say, this is not the sole case of the invention.

[0365] **FIG. 59** shows a magnetic tape cassette according to an example of the ninth aspect of the invention. As shown, the magnetic tape cassette generally indicated by **460** consists of an upper half **461** and a lower half **462** that combine to form the housing (cassette case). A slider **463** is fitted to the underside of the lower half **462** and a lid **464** is provided

at the front face of the cassette (which is closer to the viewer). The slider **463** can slide back and forth on the underside of the lower half **462** so that when the cassette is not in service, the slider prevents dust from getting into the cassette by closing the opening in the lower part of the cassette case. The lid **464** on the upper half **461** is pivotally mounted on a shaft **464a** so that it can open or close the front face of the cassette. Again, those parts of the magnetic tape cassette which are not shown in **FIG. 59** are identical to the corresponding parts of the magnetic tape cassette shown in **FIG. 1** and need not be described in detail in the following.

[0366] The housing of the magnetic tape cassette **460** contains magnetic tape (not shown) as it is wound around a pair of take-up hubs. The upper half **461** has a transparent window **466** through which the residual amount of tape in the magnetic tape cassette **460** can be checked as when it has been taken out of the deck (not shown).

[0367] The example under consideration is characterized in that the window **466** can be easily separated for recovery from the upper half **461** which is a component of the housing of the magnetic tape cassette.

[0368] To this end, the window **466** in the magnetic tape cassette **460** is so adapted as to permit easy breaking and separating. Conventionally, the window **466** is molded by injecting a molten resin through a gate provided at the center of the window **466**. This is not the case of the example under consideration and, as shown in **FIG. 59**, a gate **467** is provided at one end of the window **466** in the longitudinal direction. A destruction mark **468** is provided at the other end of the window **466** which is diametrically opposite the gate **467** in the longitudinal direction. The destruction mark **468** indicates that if a force is applied to the position of that mark, the window **466** can be easily split and separated from the upper half **461**.

[0369] It is generally known that injection molded articles are prone to break in the direction of flow of a molten resin. Given the same wall thickness, the molten resin tends to flow uniformly in a radial direction from the gate. In the case of injection molding the window **466** in the magnetic tape cassette shown in **FIG. 59**, the molten resin coming out of the gate **467** spreads radially outward to yield a molding as shown in **FIG. 60**. If a force is applied to a certain point P, a crack **469** develops and progresses toward the gate **467** in a direction perpendicular to the lines along which the resin spread radially.

[0370] This property of injection molded articles is effectively used in the example under consideration and the destruction mark **468** is provided on the window **466** in a position diametrically opposite the gate **467** in the longitudinal direction as shown in **FIGS. 59 and 61**. Stated specifically, the gate **467** is at the mid-point of one of the two shorter sides of the window **466** (to be exact, at a point slightly inward of the mid-point) and the destruction mark **468** which is diametrically opposite the gate **467** is correspondingly at the mid-point of the other shorter side of the window **466** (to be exact, at a point slightly inward of the mid-point). By applying a force to the destruction mark **468**, one can split it into two neat shapes along the line extending straight toward the gate **467**.

[0371] The manner of providing the destruction mark **468** is not limited to any particular way. A special die assembly

may be used to provide a triangular or other marks as the window **466** is injection molded. A stamp may later be impressed on the molded window. If desired, a specified mark or letters stating in effect PRESS TO SPLIT may be printed, or a seal stating to that effect may be attached.

[0372] The window **466** may be molded simultaneously with the upper half **461** in two colors using the same die assembly; alternatively, the two parts may be molded as separate entities.

[0373] If desired, the window **466** may be so designed that its shorter sides (ends) **466a** and **466b** which cross the straight line connecting the gate **467** and the destruction mark **468** are not fixed to the upper half **461** whereas its longer sides **466c** and **466d** which do not cross the straight line are fixed to the upper half **461**; this design allows the window **466** to break into two neat shapes along the center line in the longitudinal direction.

[0374] The longer sides **466c** and **466d** of the window **466** need not altogether be secured to the upper half **461** but, as shown in **FIG. 62**, a plurality of lugs **470** may be formed on each of those sides to provide exclusive areas where the window is bonded to the upper half **461**. The advantage of this design is that once the window **466** is broken into two parts in the longitudinal direction, each part can be easily separated from the upper half **461** since it is only fixed to the upper half **461** in selected areas.

[0375] On the other hand, if the window **466** breaks under a very small force that is applied to the destruction mark **468**, the strength of the product cannot be assured during normal use. Hence, cracking should not develop unless the destruction mark **468** is given a sufficient force to break the window **466**. However, it is not desirable that the window **466** do not break until after considerable force is applied to the destruction mark **168**. To meet these requirements, the design illustrated in **FIG. 63** may be adopted, in which a small cutout **472** is made on the side **466b** where the destruction mark **468** is provided as shown; if a force is exerted at the destruction mark **468** in a direction toward the gate **467**, cracking develops and will progress smoothly from the destruction mark **468** toward the gate **467**.

[0376] Thus, a force is applied to the destruction mark **468** in a direction parallel to the direction in which the cutout **472** is made; even if the applied force is not great enough, cracking will progress from the cutout **472** toward the gate **467** and the window **466** can break easily. To provide an area for the cutout **472**, the window **466** is preferably of such a length that the side **466b** slightly overlaps the upper half **461** and the cutout **472** may be provided in the overlap. This design eliminates the possibility for dirt to get into the magnetic tape cassette via the cutout **472**.

[0377] An alternative design is illustrated in **FIG. 64**, in which the window **466** is provided with a straight groove **474** along its length to connect the gate **467** and the destruction mark **468**. If the groove **474** is too deep, the window **466** may potentially break under a small impact during normal use. In addition, the groove **474** needs only to help cracking progress toward the gate **467** after a force was applied to the destruction mark **468** in order to break the window **466**. Hence, the groove **474** need not be deeper than necessary.

[0378] Depending on the type of magnetic tape cassette, ribs for regulating the positions of magnetic tape take-up

hubs are provided inside the window. In this case, a crack that develops at the destruction mark upon application of a force and which propagates toward the gate may stop at the ribs or divert laterally and the window sometimes fails to split neat in the longitudinal direction.

[0379] Even in these cases, the groove 474 shown in FIG. 64 serve as a guideline along which cracking propagates smoothly enough to ensure that the window breaks neat in the longitudinal direction.

[0380] Alternatively, the ribs may be provided with a cutout in those areas which intersect with the propagation of cracking from the destruction mark toward the gate.

[0381] As already mentioned, in the usual case of injection molding the window, the gate is located at the center of the window. Even in this case, the destruction mark may be provided near the center of one of the two shorter sides of the window in the longitudinal direction as in the foregoing example and if the destruction mark is depressed, a crack develops and propagates toward the central gate. If the window is split in a favorable manner, the crack will go beyond the central gate to progress unimpeded toward the opposite shorter side. Thus, the method of providing the destruction mark according to the example under consideration is effective even in the conventional process of injection molding the window.

[0382] While the window has been assumed to have a rectangular shape in the foregoing example, various other shapes may also be adopted. Even in the case of non-rectangular windows, the destruction mark may be provided in such positions that upon application of an impact to the mark, cracking develops at the affected point and propagates toward the gate. For example, the destruction mark may be provided on the window in the position which is the farthest from the gate.

[0383] Considering the relative positions of the gate and the destruction mark, it is generally recommended that the gate and the destruction mark be provided in such positions that they are connected by the longest straight line that can be drawn to traverses the window. In this case, the window can be split into two halves of generally the same size and it is easy to separate them later for recovery from the upper half.

[0384] On the foregoing pages, an example of the ninth aspect of the invention has been described in detail and according to this example, the transparent window provided in the upper half of a magnetic tape cassette to help check the residual amount of magnetic tape can be easily broken so that it is separated from the upper half in a smooth, positive and safest way.

[0385] It should be noted that the concept of the ninth aspect of the invention is not only applicable to the transparent window of a magnetic tape cassette, it is also applicable to other shaped resin articles in general.

[0386] Described above are the basic features of the ninth aspect of the invention.

[0387] While a magnetic tape cassette, a process for producing it, a resin shaped article, a method for multi-color molding of resin products and a method for destructing and separating parts made of dissimilar materials have been described on the foregoing pages in detail with reference to

various examples to the extent that they are within the scope of the present invention, it should be noted that the examples are intended for illustrative purposes only and are by no means taken to limit the invention. Obviously, the concept of the invention allows for easy modification of details of various design considerations and it is equally applicable to other models of magnetic tape cassette. It goes without saying that various improvements and modifications are possible without departing from the scope and spirit of the invention.

[0388] For example, the separable transparent window having the structure described above is not only used to check the residual amount of tape in the magnetic tape cassette; obviously, the same structure is equally applicable to the purpose of installing a variety of transparent windows intended for visually checking the interior of the tape cassette, particularly those provided in other models of magnetic tape cassette.

[0389] In addition, the various methods described in the foregoing examples for coupling parts of dissimilar resins (plastics) are applicable to a wide variety of resin (plastic) products other than the magnetic tape cassette.

[0390] As described above in detail, the magnetic tape cassette according to the first aspect of the invention is characterized in that the transparent window consisting of a window member and a base (an upper half's body) that are not welded together can be easily disassembled and that the two components can be completely separated without letting part of the window member stick to the base or vice versa, with the advantage that they can be recycled as feeds for additional products without suffering a drop in purity.

[0391] As described above in detail, the second aspect of the invention brings about the same advantages as the first aspect.

[0392] In addition, the window member can be separated from the base in an easy and safest manner, thus contributing utmost safety to the operating personnel.

[0393] As described above in detail, according to the third aspect of the invention, the opening in the upper half's body serving as the base of the upper half has such a cross-sectional shape that it has a recess in both an upper and a lower surface and an edge portion that bridges the two recesses and the window member is directly molded in the opening, thereby providing the same advantages as in the first aspect.

[0394] In addition, the die assembly for molding the window member has a first and a second retractable core, so both the upper half and the window member can be molded with the same die assembly by changing only the positions of the two cores; as a result, the die assembly can be prepared at low cost.

[0395] As described above in detail, according to the fourth aspect of the invention, two or more incompatible resin materials that are not adherent to each other are used in a core backing, multi-color molding method to mold parts of the resin materials in multiple colors at substantially the same timing using a single die assembly; then, the respective parts are demolded and recombined together, whereby all parts are installed in one step to make a resin product. The thus assembled parts can be easily separated and recovered for recycling.

[0396] As described above in detail, the first embodiment of the fifth aspect of the invention can bring about the same advantages as the first aspect.

[0397] As described above in detail, the magnetic cassette case according to the second embodiment of the fifth aspect of the invention is characterized in that the areas in which the window member is joined to the base (the upper half's body) around the opening in it are formed to have a cross section which is asymmetric with respect to the center line and which has an inclined plane; hence, the base and the window member which are the two components of the window are not welded together and the window member once fitted into the base is substantially immobile. The resulting upper half is not only adequately air-tight, it also has sufficient strength against external forces. In the second embodiment under consideration, the window member can be easily separated from the opening in the base by pushing it at an angle; this is the same advantage as obtained in the first aspect of the invention.

[0398] As described above in detail, according to the third embodiment of the fifth aspect of the invention, a circular opening is made in the base of the upper half and a correspondingly circular window member is threaded into the opening; this design contributes to providing the same advantage as in the first aspect of the invention.

[0399] If the window member has a flange, it can be firmly secured to provide an upper half which is not only air-tight but also strong enough to resist external pressure and impact.

[0400] As described above in detail, the sixth aspect of the invention realizes a shaped resin article that is formed of parts of dissimilar materials and which permits the respective parts to be easily separated and recovered for recycling.

[0401] As described above in detail, the seventh aspect of the invention can bring about the same advantages as the first aspect.

[0402] As described above in detail, according to the eighth aspect of the invention, a smaller amount of heat is emitted in the recycling processes, contributing to preservation of the earth's environment and prevention of global warming.

[0403] As described above in detail, according to the ninth aspect of the invention, a shaped resin article made of parts of dissimilar materials can be destructed in a simple, positive and safest way so that they are efficiently separated for recovery.

[0404] Thus, according to the various aspects of the invention, there are provided magnetic tape cassettes of structures that permit utmost safety in the operation of separating the window member from the body of the upper half of the magnetic tape cassette that has been discarded after use.

[0405] According to the various aspects of the invention, there are also provided magnetic tape cassettes which will emit a smaller amount of heat even if part of the discarded tape cassette should be subjected to thermal recycling. Thus, according to the various aspects of the invention, one can provide magnetic tape cassettes that emit a smaller amount of heat in the recycling processed, contributing to preservation of the earth's environment and prevention of global warming.

What is claimed is:

- 1. A magnetic tape cassette having:
 - a base with an opening for forming a transparent window;
 - a transparent material-made window member to be installed in said opening; and
 - joining means provided on either said base or said window member or both in order to install said window member within said opening in said base.

2. The magnetic tape cassette according to claim 1, wherein

- said joining means comprises:
 - a first wedge-shaped projection on an inner perimeter of said base around said opening which forms said window; and
 - a second wedge-shaped projection on the outer perimeter of said window member, and
 - said first projection on said base is brought into engagement with said second projection on said window member, whereby

said window is installed within said opening in said base.

3. The magnetic tape cassette according to claim 2, wherein

- said joining means comprises:
 - a window frame for supporting said window member on an inner perimeter of said base around said opening; and
 - an engaging pawl that is so shaped as to fit to said base and which holds said window frame of said base by engaging its lower edge, and

said engaging pawl of said window member is brought into engagement with said window frame of said base so that said window member is installed within said opening in said base.

4. The magnetic tape cassette according to claim 1, wherein a joint portion established by said joining means between said window member and said opening in said base has a generally V-shaped cross section with an inclined portion.

5. The magnetic tape cassette according to claim 1, wherein an inner perimeter of said opening in said base is shaped in a circular form, an outer perimeter of said window member is shaped in a circular form so that it can be installed with said circular opening in said base, and wherein said engaging means comprises an engaging projection provided on either the inner circular perimeter of said opening or the outer circular perimeter of said window member and an engaging portion provided on either the outer circular perimeter of said window member or the inner circular perimeter of said opening to come into engagement with said engaging projection, said window member being fitted into said opening in said base and rotated until it is secured in such a way as to close said opening.