

C. E. LEWIS.

Thread-Waxing Attachment for Sewing-Machines.

No. 134,606.

Patented Jan. 7, 1873.

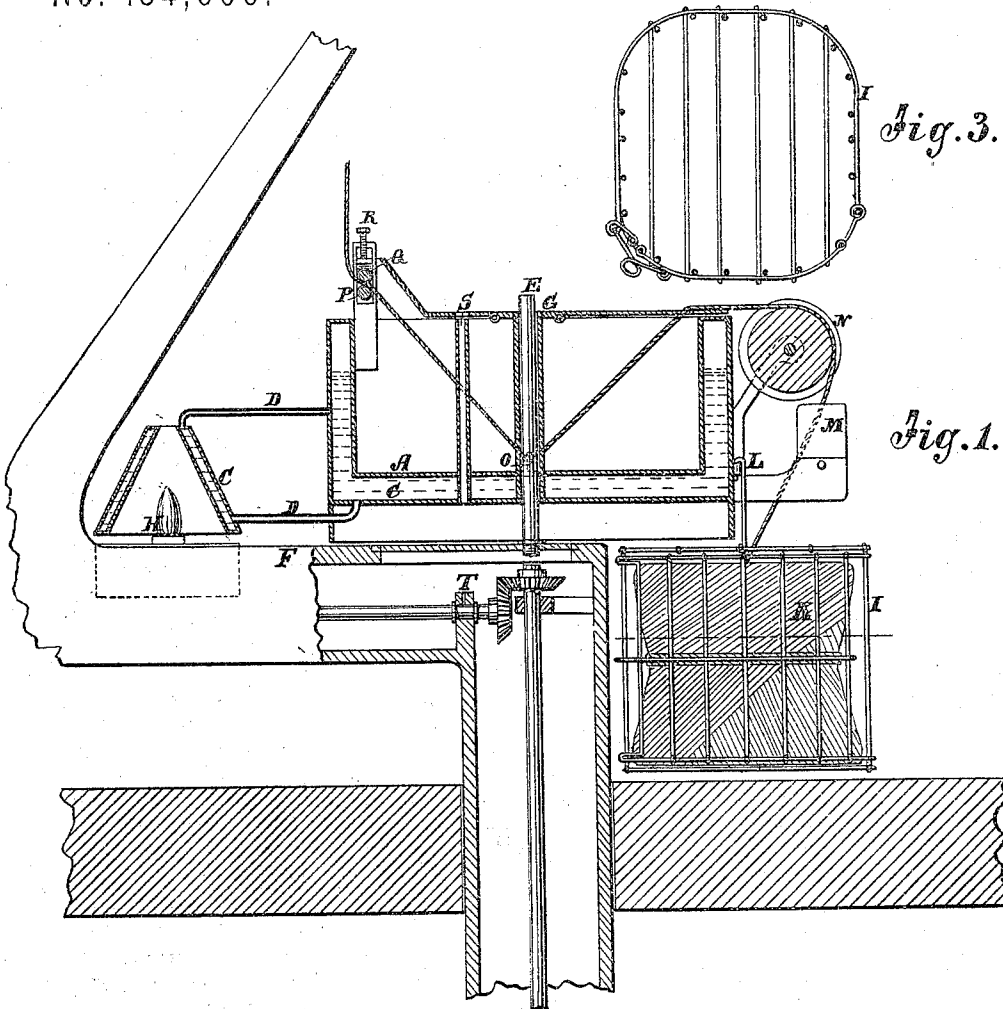
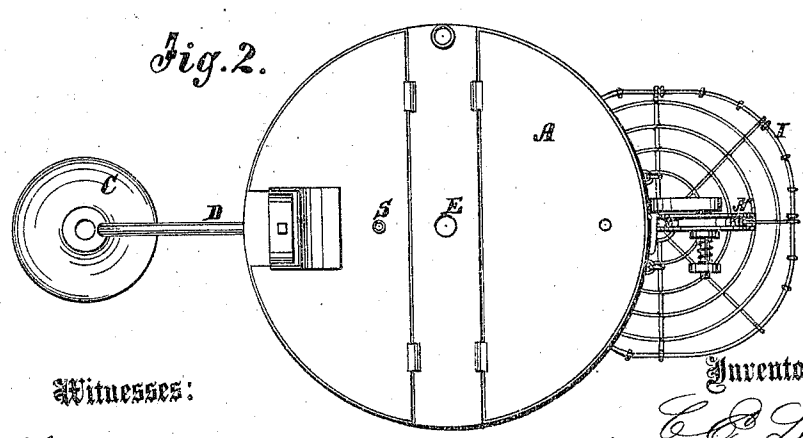

Fig. 3.

Fig. 1.

Fig. 2.



Witnesses:

A. Remmenndorf.  
C. Sedgwick

Inventor:

C. E. Lewis

PER

M. M. M.  
Attorneys.

# UNITED STATES PATENT OFFICE.

CLAY E. LEWIS, OF YORK, PENNSYLVANIA.

IMPROVEMENT IN THREAD-WAXING ATTACHMENTS FOR SEWING-MACHINES.

Specification forming part of Letters Patent No. 134,606, dated January 7, 1873.

*To all whom it may concern:*

Be it known that I, CLAY E. LEWIS, of York, in the county of York and State of Pennsylvania, have invented a new and Improved Thread-Waxing Attachment for Sewing-Machines, of which the following is a specification:

The invention consists in a heater, arranged as hereinafter described, for heating the horn and waxing attachment.

Figure 1 is a sectional elevation of my improved waxing attachment and stripping device; also a part of the machine. Fig. 2 is a horizontal section of the bobbin-cage taken on the line *x x* of Fig. 1. Fig. 3 is a plan view of the attachment.

Similar letters of reference indicate corresponding parts.

A represents a wax-cup, with a jacket, B, inclosing a space, C, for the circulation of hot water from the heater C attached to it by the connecting-pipes D, which are relatively arranged with the cup A, so that when the latter is mounted on the spool-spindle E of the horn F of a "McKay" wax-thread machine, for which said cup is provided with a socket, G, the said heater will be supported over the flame H, commonly maintained at the angle of the horn for heating the upper portion of it, so that the heater will also be heated by it, and will not obstruct the action of the flame upon the under side of the horn for heating it, as heretofore. I is a bobbin-cage for holding the bobbin or ball K of unwaxed thread to be waxed, and supplied to the machine as the work progresses; it is suspended from the side of the wax-cup by hooks L, or any other suitable contrivance. The bobbin-cage being constructed of wire, with large openings, is more desirable than a cup of close material would be, because the bobbin is always in view. M represents a spring-clamp, and N a tension-

wheel, mounted on the side of the cup above the cage suitably for the thread to pass through in its course from the cage to the wax-cup for receiving the tension. O is a guide in the bottom of the cup for conducting the thread down through the wax; and P represents a pair of grooved stripping-rollers, mounted on the top of the cup, for the thread to pass through from the wax to the needle for removing the surplus wax. The upper roller is movable toward and from the other to vary the pressure, and a spring, Q, is introduced between it and the adjusting-screw to allow the roller to be self-adjusting to the thread as it varies in thickness. These rollers are equally as efficient for removing the surplus wax as the blocks heretofore used, and they are very superior to them in their action on the knots, lumps, &c., in the thread and in their effect on the tension, because they compress the knots and do not hitch or obstruct the thread when they pass and interfere with or affect the tension. S is a tube fitted in the wax-cup so as to conduct oil for lubricating the bearing T of the sewing-machine through it, to save the labor of removing it for applying the oil. With an attachment of this character the thread is only waxed as the work progresses, so that none is lost by the wax becoming too hard by long standing, as is the case when large bobbins of waxed thread are prepared beforehand.

Having thus described my invention, I claim as new and desire to secure by Letters Patent—

The arrangement of heater C with waxing attachment and horn so that the former heats both, substantially as specified.

CLAY E. LEWIS.

Witnesses:

JOHN A. WILSON,  
JOHN W. STEWART.