

Oct. 17, 1933.

W. A. STAFF  
ADJUSTABLE PENCIL HOLDER

1,931,138

Filed Jan. 4, 1933

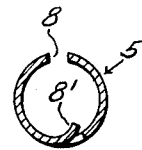
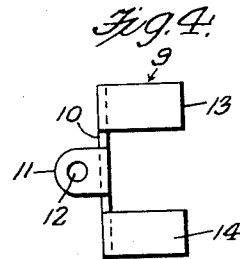
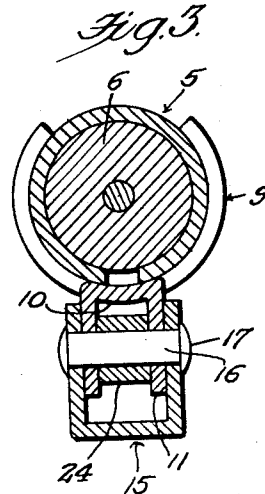
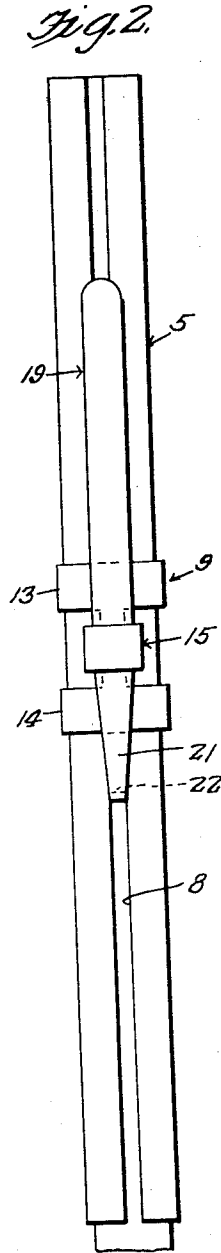
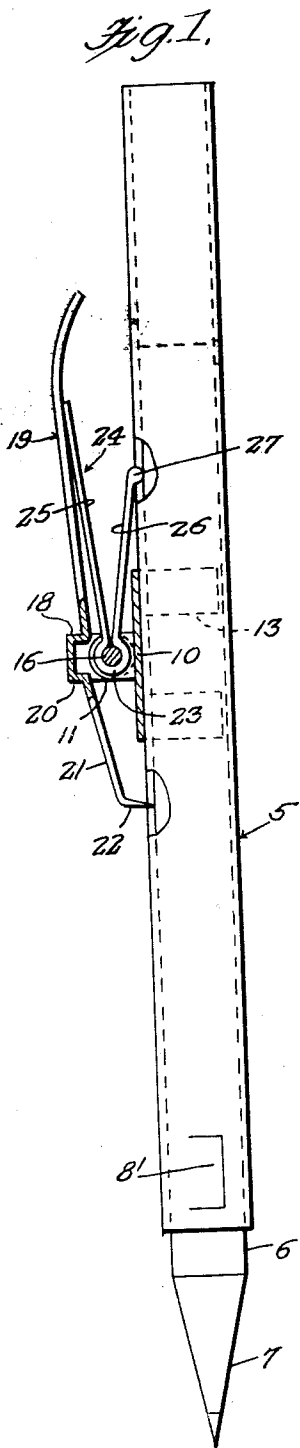

Inventor

*William A. Staff,*

By *Clarence A. O'Brien,*  
Attorney

# UNITED STATES PATENT OFFICE

1,931,138

## ADJUSTABLE PENCIL HOLDER

William A. Staff, Chicago, Ill.

Application January 4, 1933. Serial No. 650,174

5 Claims. (Cl. 24-11)

My invention relates generally to pencil holders, and particularly to an adjustable pencil holder wherein a novel arrangement and combination of parts is utilized to produce a structure which may act as a guard for the pointed end and for the eraser equipped end of the pencil used therewith, when these are not in use.

It is also an important object of my invention to provide a light-weight, neat, convenient and relatively inexpensive pencil holder of the type described, which is adjustable so that when the pencil is not in use for writing or erasing, the pointed end of the pencil and the eraser equipped end of the pencil will be positively covered and protected, while the pencil and holder is being carried about as in the pocket.

Other objects and advantages of my invention will be apparent from a reading of the following description in connection with the drawing, wherein for purposes of illustration I have shown a preferred embodiment of my invention.

In the drawing:—

Figure 1 is a general side elevational view of the embodiment showing the pointed end of a pencil extended therefrom and

Fig. 2 is an elevational view taken approximately at right angles to Fig. 1, looking from the left.

Fig. 3 is a horizontal sectional view through Fig. 1.

Fig. 4 is a side elevational view of a slide and Fig. 5 is a horizontal sectional view through the lower end portion of the holder.

Referring in detail to the drawing, wherein like numerals refer to like parts throughout the same, the numeral 5 generally designates a tube of uniform diameter in which is closely and slidably received an ordinary lead pencil 6 having the pointed end 7. The lower end portion of the tubular holder 5 has a punched out portion 8 which is curvedly and inwardly directed as indicated in Fig. 5 so as to bear against and slightly dig into the side of the pencil for holding the same against too free sliding in the holder.

In one side and extending the full length of the holder 5 is a relatively narrow slot 8. Mounted upon the exterior of the holder and slidable thereon for the full length of the holder is a bracket member generally designated 9 which comprises the longitudinal web portion 10 from opposite edges of the central portion of which proceed ears 11 having a hole 12 therein. From opposite ends of the same edges proceed laterally curved upper arms 13 and similar lower arms 14. The pairs of arms 13, 13 and 14, 14 have a

suitable curvature for frictionally and slidably embracing the exterior of the holder 5 so as to be carried by the tube. The web portion 10 has a slight transverse curvature as seen in Fig. 3 to conform to the contour of the exterior of the holder. Normally the web portion 10 will be located over the slot 8.

A U-shaped member 15 has passed through its arms, a pivot pin 16 which is riveted as indicated at 17 on the outside of the said arms. This pin is arranged to pass also through the holes 12 in the ears of the slide 9 so that the arms of the U-shaped member 15 are outside of and movably engaged with the ears 11 as shown in Fig. 3.

The U-shaped member 15 has on its bight portion an inwardly projecting portion 18 on the end of which is formed a long arm 19 which is herein called the operating arm which has the normal vertical disposition shown in Fig. 1. From another inwardly projecting portion 20 on the lower edge of the bight portion of the U-shaped member 15 there projects downwardly at an angle a tapered pencil engaging member 21 which has on its lower end a horizontally directed point 22 for engagement through the slot 8 and into the side of the pencil 6. It will be observed that the operating arm 19 is flat and comparatively wide while the pencil engaging member 21 is flat and tapering.

On the pivot pin 16 between the ears 11 is an ear portion 23 of a spring member generally designated 24 which is generally V-shaped in form and has a long leg 25 outwardly disposed against the inside surface of the operating member 19 and the relatively short arm 26 working in the opposite direction against the holder 5 whereby to maintain the operating member 19 normally diverged away from the holder 5 and the pencil engaging member 21 forced through the slot 8 so as to bite with its point 22 into the side of the pencil. The short arm 26 of the spring 24 has an expanded portion 27 which rests against the side of the holder and has a portion which projects through the slot 8 so as to endow the slot 8 with a guiding function. It will be obvious that the arms 25, 26 are provided to have a normal tendency to spread away from each other and produce the pencil holding actions described.

It will be obvious that whenever the operating member 19 is pressed toward the holder 5, the point 22 will be released from the pencil so that the pencil may be adjusted in the holder relative to the clamping structure. It will also be obvious that when the point 22 is engaged with

the pencil, that the pencil and the clamping structure being thus connected, and may be slid relative to the holder.

This arrangement makes it possible to sheath either end of the pencil within the holder in such a way that it will stay sheathed during carrying of the device in the pocket. Because of the slidable mounting of the slide 9, the entire clamping structure may be slid relative to the holder whenever the point 22 has been released from the pencil, or when not released from the pencil, the pencil will slide with the clamping structure. Due to the adjustability of the clamping structure practically the full length of the holder, pencils of varying lengths, even very short lengths of pencils may be utilized with complete convenience in my invention. Since it is the breaking of pencil points which entails resharpening of the pencil, which most quickly consumes a pencil, it will be obvious that the device of the invention providing for complete sheathing of the pointed end or of the eraser equipped end, provides for preservation of these ends when the pencil and holder is not in use, thereby effecting considerable economies.

Though I have shown and described herein a preferred embodiment of my invention, it is to be definitely understood that I do not desire to limit the application of my invention thereto, and any change or changes may be made in material and structure and arrangement of parts, within the spirit of the invention and the scope of the subjoined claims.

Having thus described my invention, what I claim as new is:—

1. A device of the character described, a tube having a full length slot in one side thereof, a slide mounted on the exterior of the tube, a clamping means carried by the slide, a portion of the clamping means being engageable through the slot with a pencil disposed within the tube for clamping the pencil and for holding it relative to the tube and to the slide.

2. In a holder for a pencil, a tube having an elongated longitudinal guide slot extending in one side of the tube, a slide mounted upon and embracing the tube, clamping means carried by the slide and having a portion engaged with the slot so as to be guided thereby and another portion disposed through the slot for engaging a pencil in the tube to hold the pencil in adjusted position in the tube, said slide being slidable to

position an end of the pencil outwardly of and inwardly of the ends of the tube.

3. In a pencil holder, a tube having a longitudinal guide slot in one side, a frame embracing and slidable on the tube, clamping means rockable on the frame and having a portion engaged with the slot to prevent rotation of the frame on the tube and another portion normally positioned through the slot and engaging a pencil in the tube to prevent longitudinal movement of the pencil in the tube independently of the frame, said other portion being manipulable out of engagement with the pencil to permit movement of the pencil in the tube independently of the frame and clamping means.

4. In a pencil holder, a tube having a longitudinal guide slot in one side, a frame embracing and slidable on the tube, clamping means rockable on the frame and having a portion engaged with the slot to prevent rotation of the frame on the tube and another portion normally positioned through the slot and engaging a pencil in the tube to prevent longitudinal movement of the pencil in the tube independently of the frame, said other portion being manipulable out of engagement with the pencil to permit movement of the pencil in the tube independently of the frame and clamping means, the first portion including expanding spring means interposed between the first portion and said other portion for urging the said other portion into clamping engagement with the pencil.

5. In a pencil holder, a tube having a longitudinal guide slot in one side, a frame embracing and slidable on the tube, clamping means rockable on the frame and having a portion engaged with the slot to prevent rotation of the frame on the tube and another portion normally positioned through the slot and engaging a pencil in the tube to prevent longitudinal movement of the pencil in the tube independently of the frame, said other portion being manipulable out of engagement with the pencil to permit movement of the pencil in the tube independently of the frame and clamping means, the first portion including expanding means interposed between the first portion and said other portion for urging the said other portion into clamping engagement with the pencil, said first portion having a part engaging the pencil through the slot.

WILLIAM A. STAFF.

55

130

60

135

65

140

70

145

75

150