



US008062400B2

(12) **United States Patent**
Maier

(10) **Patent No.:** **US 8,062,400 B2**

(45) **Date of Patent:** **Nov. 22, 2011**

(54) **DUAL BODY DRUM FOR ROTARY SEPARATORS**

(75) Inventor: **William C. Maier**, Almond, NY (US)

(73) Assignee: **Dresser-Rand Company**, Olean, NY (US)

(*) Notice: Subject to any disclaimer, the term of this patent is extended or adjusted under 35 U.S.C. 154(b) by 387 days.

(21) Appl. No.: **12/215,068**

(22) Filed: **Jun. 25, 2008**

(65) **Prior Publication Data**

US 2009/0321343 A1 Dec. 31, 2009

(51) **Int. Cl.**
B01D 46/18 (2006.01)

(52) **U.S. Cl.** **55/400; 55/406; 55/407; 55/408; 95/270; 210/787; 210/512.1; 210/360.1**

(58) **Field of Classification Search** **55/400, 55/406-408; 95/270; 210/338, 342, 359, 210/360.1, 378, 402**

See application file for complete search history.

(56) **References Cited**

U.S. PATENT DOCUMENTS

815,812 A	3/1906	Gow	
1,057,613 A *	4/1913	Baldwin	95/218
1,061,656 A *	5/1913	Black	494/74
1,480,775 A	1/1924	Marien	
1,622,768 A	3/1927	Cook et al.	
1,642,454 A	9/1927	Malmstrom	
2,006,244 A	6/1935	Kopsa	
2,300,766 A	11/1942	Baumann	
2,328,031 A	8/1943	Risley	
2,345,437 A	3/1944	Tinker	
2,602,462 A	7/1952	Barrett	

2,811,303 A	10/1957	Ault et al.
2,836,117 A	5/1958	Lankford
2,868,565 A	1/1959	Suderow
2,897,917 A	8/1959	Hunter
2,932,360 A	4/1960	Hungate
2,954,841 A	10/1960	Reistle

(Continued)

FOREIGN PATENT DOCUMENTS

CA 2647511 10/2007

(Continued)

OTHER PUBLICATIONS

Technical Manual—High Pressure Air Compressor Model 13NL45; Naysea 86220-AT-MMA-010/93236, pp. 3-23 to 3-32, Electric Boat Corporation, Groton, CT 06340, Oct. 28, 1991. .

(Continued)

Primary Examiner — Jason M Greene

Assistant Examiner — Dung Bui

(74) *Attorney, Agent, or Firm* — Edmonds & Nolte, PC

(57) **ABSTRACT**

A drum is for a rotary separator including a shaft rotatable about a central axis. The drum includes an inner drum member having inner and outer circumferential surfaces and being disposed generally about the shaft such that a first flow passage is generally defined between the inner drum member inner surface and the shaft. The inner drum inner surface is configured to separate liquids from a fluid flow contacting the surface. An outer drum member has inner and outer circumferential surfaces and is disposed generally about the inner drum member such that a second flow passage is generally defined between the outer drum member inner surface and the inner drum member outer surface, the second flow passage being generally coaxial with the first flow passage. Further, the outer drum inner surface is also configured to separate liquids from a fluid flow contacting the surface.

23 Claims, 5 Drawing Sheets

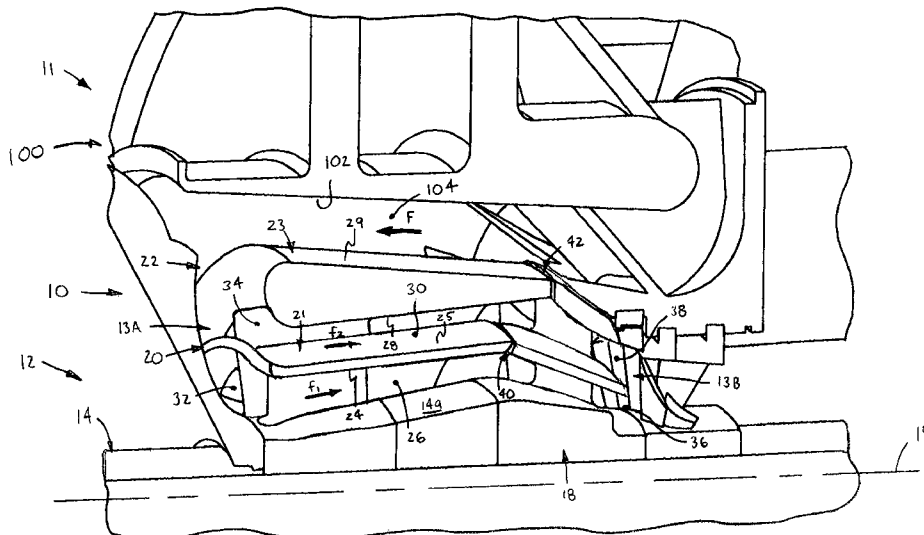

U.S. PATENT DOCUMENTS							
3,044,657	A	7/1962	Horton	4,826,403	A	5/1989	Catlow
3,191,364	A	6/1965	Sylvan	4,830,331	A	5/1989	Vindum
3,198,214	A	8/1965	Lorenz	4,832,709	A	5/1989	Nagyszalanczy
3,204,696	A	9/1965	De Priester et al.	4,904,284	A	2/1990	Hanabusa
3,213,794	A	10/1965	Adams	4,984,830	A	1/1991	Saunders
3,220,245	A	11/1965	Van Winkle	5,007,328	A	4/1991	Otteman
3,273,325	A	9/1966	Gerhold	5,024,585	A	6/1991	Kralovec
3,352,577	A	11/1967	Medney	5,043,617	A	8/1991	Rostron
3,395,511	A	8/1968	Ernst	5,044,701	A	9/1991	Watanabe et al.
3,420,434	A	1/1969	Swearingen	5,045,046	A	9/1991	Bond
3,431,747	A	3/1969	Hasheimi et al.	5,054,995	A	10/1991	Kaseley et al.
3,454,163	A	7/1969	Read	5,064,452	A	11/1991	Yano et al.
3,487,432	A	12/1969	Jensen	5,080,137	A	1/1992	Adams
3,490,209	A	1/1970	Fernandes et al.	5,190,440	A	3/1993	Maier et al.
3,500,614	A	* 3/1970	Soo	5,202,024	A	4/1993	Andersson et al.
3,578,342	A	5/1971	Satterthwaite et al.	5,202,026	A	4/1993	Lema
3,628,812	A	12/1971	Larralde et al.	5,203,891	A	4/1993	Lema
3,672,733	A	6/1972	Arsenius et al.	5,207,810	A	5/1993	Sheth
3,814,486	A	6/1974	Schurger	5,211,427	A	5/1993	Washizu
3,829,179	A	8/1974	Kurita et al.	5,246,346	A	9/1993	Schiesser
3,915,673	A	* 10/1975	Tamai et al.	5,285,123	A	2/1994	Kataoka et al.
3,975,123	A	8/1976	Schibbye	5,306,051	A	4/1994	Loker et al.
4,033,647	A	7/1977	Beavers	5,337,779	A	8/1994	Fukuhara
4,059,364	A	11/1977	Andersen et al.	5,378,121	A	1/1995	Hackett
4,078,809	A	3/1978	Garrick et al.	5,385,446	A	1/1995	Hays
4,087,261	A	5/1978	Hays	5,421,708	A	6/1995	Utter
4,103,899	A	8/1978	Turner	5,443,581	A	8/1995	Malone
4,112,687	A	9/1978	Dixon	5,484,521	A	1/1996	Kramer
4,117,359	A	9/1978	Wehde	5,496,394	A	3/1996	Nied
4,135,542	A	1/1979	Chisholm	5,500,039	A	3/1996	Mori et al.
4,141,283	A	2/1979	Swanson et al.	5,525,034	A	6/1996	Hays
4,146,261	A	3/1979	Edmaier et al.	5,525,146	A	6/1996	Straub
4,165,622	A	8/1979	Brown, Jr.	5,531,811	A	7/1996	Kloberdanz
4,174,925	A	11/1979	Pfenning et al.	5,538,259	A	7/1996	Uhrner et al.
4,182,480	A	* 1/1980	Theyse et al.	5,542,831	A	8/1996	Scarfone
4,197,990	A	4/1980	Carberg et al.	5,575,309	A	11/1996	Connell
4,205,927	A	6/1980	Simmons	5,585,000	A	12/1996	Sassi
4,227,373	A	10/1980	Amend et al.	5,605,172	A	2/1997	Schubert et al.
4,258,551	A	3/1981	Ritzi	5,628,623	A	5/1997	Skaggs
4,259,045	A	3/1981	Teruyama	5,634,492	A	6/1997	Steinruck et al.
4,278,200	A	7/1981	Gunnewig	5,640,472	A	6/1997	Meinzer et al.
4,298,311	A	11/1981	Ritzi	5,641,280	A	6/1997	Timuska
4,333,748	A	6/1982	Erickson	5,653,347	A	8/1997	Larsson
4,334,592	A	6/1982	Fair	5,664,420	A	9/1997	Hays
4,336,693	A	6/1982	Hays et al.	5,682,759	A	11/1997	Hays
4,339,923	A	7/1982	Hays et al.	5,683,235	A	11/1997	Satterthwaite et al.
4,347,900	A	9/1982	Barrington	5,685,691	A	11/1997	Hays
4,363,608	A	12/1982	Mulders	5,687,249	A	11/1997	Kato
4,374,583	A	2/1983	Barrington	5,693,125	A	12/1997	Dean
4,375,975	A	3/1983	McNicholas	5,703,424	A	12/1997	Dorman
4,382,804	A	5/1983	Mellor	5,709,528	A	1/1998	Hablanian
4,384,724	A	5/1983	Derman et al.	5,713,720	A	2/1998	Barhoum
4,391,102	A	7/1983	Studhalter et al.	5,720,799	A	2/1998	Hays
4,396,361	A	8/1983	Fraser	5,750,040	A	5/1998	Hays
4,432,470	A	2/1984	Sopha	5,775,882	A	7/1998	Kiyokawa et al.
4,438,638	A	3/1984	Hays et al.	5,779,619	A	7/1998	Borgstrom et al.
4,441,322	A	4/1984	Ritzi	5,795,135	A	8/1998	Nyilas et al.
4,442,925	A	4/1984	Fukushima et al.	5,800,092	A	9/1998	Nill et al.
4,453,893	A	6/1984	Hutmaker	5,848,616	A	12/1998	Vogel et al.
4,463,567	A	8/1984	Amend et al.	5,850,857	A	12/1998	Simpson
4,468,234	A	8/1984	McNicholas	5,853,585	A	12/1998	Nesseth
4,471,795	A	9/1984	Linhardt	5,863,023	A	1/1999	Evans et al.
4,477,223	A	10/1984	Giroux	5,899,435	A	5/1999	Mitsch et al.
4,502,839	A	3/1985	Maddox et al.	5,935,053	A	* 8/1999	Strid et al.
4,511,309	A	4/1985	Maddox	5,938,803	A	8/1999	Dries
4,531,888	A	7/1985	Buchelt	5,938,819	A	8/1999	Seery
4,536,134	A	8/1985	Huiber	5,946,915	A	9/1999	Hays
4,541,531	A	9/1985	Brule	5,951,066	A	9/1999	Lane et al.
4,541,607	A	9/1985	Hotger	5,965,022	A	10/1999	Gould
4,573,527	A	3/1986	McDonough	5,967,746	A	10/1999	Hagi et al.
4,574,815	A	3/1986	West et al.	5,971,702	A	10/1999	Afton et al.
4,648,806	A	3/1987	Alexander	5,971,907	A	10/1999	Johannemann et al.
4,687,017	A	8/1987	Danko et al.	5,980,218	A	11/1999	Takahashi et al.
4,737,081	A	4/1988	Nakajima et al.	5,988,524	A	11/1999	Odajima et al.
4,752,185	A	6/1988	Butler et al.	6,035,934	A	3/2000	Stevenson et al.
4,807,664	A	2/1989	Wilson et al.	6,059,539	A	5/2000	Nyilas et al.
4,813,495	A	3/1989	Leach	6,068,447	A	5/2000	Foege
4,821,737	A	4/1989	Nelson	6,090,174	A	7/2000	Douma et al.
				6,090,299	A	7/2000	Hays et al.

US 8,062,400 B2

6,113,675 A	9/2000	Branstetter	7,288,202 B2	10/2007	Maier
6,122,915 A	9/2000	Hays	7,314,560 B2	1/2008	Yoshida et al.
6,123,363 A	9/2000	Burgard et al.	7,323,023 B2	1/2008	Michele et al.
6,145,844 A	11/2000	Waggott	7,328,749 B2	2/2008	Reitz
6,149,825 A	11/2000	Gargas	7,335,313 B2	2/2008	Moya
6,151,881 A	11/2000	Ai et al.	7,377,110 B2	5/2008	Sheridan et al.
6,196,962 B1	3/2001	Purvey et al.	7,381,235 B2	6/2008	Koene et al.
6,206,202 B1	3/2001	Galk et al.	7,396,373 B2	7/2008	Lagerstedt et al.
6,214,075 B1	4/2001	Filges et al.	7,399,412 B2	7/2008	Keuschnigg
6,217,637 B1 *	4/2001	Toney et al. 95/277	7,435,290 B2	10/2008	Lane et al.
6,227,379 B1	5/2001	Neseth	7,445,653 B2	11/2008	Trautmann et al.
6,277,278 B1	8/2001	Conrad et al.	7,470,299 B2	12/2008	Han et al.
6,312,021 B1	11/2001	Thomas	7,473,083 B2	1/2009	Oh et al.
6,314,738 B1	11/2001	Hays	7,479,171 B2	1/2009	Cho et al.
6,372,006 B1	4/2002	Pregenzer et al.	7,494,523 B2	2/2009	Oh et al.
6,375,437 B1	4/2002	Nolan	7,501,002 B2	3/2009	Han et al.
6,383,262 B1	5/2002	Marthinsen et al.	7,520,210 B2	4/2009	Theodore, Jr. et al.
6,394,764 B1	5/2002	Samurin	7,575,422 B2	8/2009	Bode et al.
6,398,973 B1	6/2002	Saunders et al.	7,578,863 B2	8/2009	Becker et al.
6,402,465 B1	6/2002	Maier	7,591,882 B2 *	9/2009	Harazim 95/270
6,426,010 B1	7/2002	Lecoffire et al.	7,594,941 B2	9/2009	Zheng et al.
6,464,469 B1	10/2002	Grob et al.	7,594,942 B2	9/2009	Polderman
6,467,988 B1	10/2002	Czachor et al.	7,610,955 B2	11/2009	Irwin, Jr.
6,468,426 B1	10/2002	Klass	7,628,836 B2	12/2009	Baronet et al.
6,485,536 B1	11/2002	Masters	7,637,699 B2	12/2009	Albrecht
6,530,484 B1	3/2003	Bosman	7,674,377 B2	3/2010	Crew
6,530,979 B2	3/2003	Firey	7,677,308 B2	3/2010	Kolle
6,531,066 B1	3/2003	Saunders et al.	7,708,537 B2	5/2010	Bhatia et al.
6,537,035 B2	3/2003	Shumway	7,708,808 B1	5/2010	Heumann
6,540,917 B1	4/2003	Richards et al.	7,744,663 B2	6/2010	Wallace
6,547,037 B2	4/2003	Kuzdzal	7,748,079 B2	7/2010	McDowell et al.
6,592,654 B2	7/2003	Brown	7,766,989 B2	8/2010	Lane et al.
6,596,046 B2	7/2003	Conrad et al.	7,811,344 B1	10/2010	Duke et al.
6,599,086 B2	7/2003	Soja	7,811,347 B2	10/2010	Carlsson et al.
6,607,348 B2	8/2003	Jean	7,815,415 B2	10/2010	Kanezawa et al.
6,616,719 B1	9/2003	Sun et al.	7,824,458 B2	11/2010	Borgstrom et al.
6,617,731 B1	9/2003	Goodnick	7,824,459 B2	11/2010	Borgstrom et al.
6,629,825 B2	10/2003	Stickland	7,846,228 B1	12/2010	Saaski et al.
6,631,617 B1	10/2003	Dreiman et al.	2001/0007283 A1	7/2001	Johal et al.
6,658,986 B2	12/2003	Pitla et al.	2002/0009361 A1	1/2002	Reichert et al.
6,659,143 B1	12/2003	Taylor et al.	2003/0029318 A1	2/2003	Firey
6,669,845 B2	12/2003	Klass	2003/0035718 A1	2/2003	Langston et al.
6,688,802 B2	2/2004	Ross et al.	2003/0136094 A1 *	7/2003	Illingworth et al. 55/406
6,707,200 B2	3/2004	Carroll et al.	2004/0007261 A1	1/2004	Cornwell
6,718,955 B1	4/2004	Knight	2004/0170505 A1	9/2004	Lenderink et al.
6,719,830 B2	4/2004	Illingworth et al.	2005/0173337 A1	8/2005	Costinel
6,764,284 B2	7/2004	Oehman, Jr.	2006/0065609 A1	3/2006	Arthur
6,776,812 B2	8/2004	Komura et al.	2006/0090430 A1	5/2006	Trautman et al.
6,802,693 B2	10/2004	Reinfeld et al.	2006/0096933 A1	5/2006	Maier
6,802,881 B2 *	10/2004	Illingworth et al. 55/394	2006/0157251 A1	7/2006	Stinessen et al.
6,811,713 B2	11/2004	Arnaud	2006/0157406 A1	7/2006	Maier
6,817,846 B2	11/2004	Bennitt	2006/0193728 A1	8/2006	Lindsey et al.
6,837,913 B2	1/2005	Schilling et al.	2006/0222515 A1	10/2006	Delmotte et al.
6,843,836 B2	1/2005	Kitchener	2006/0230933 A1 *	10/2006	Harazim 95/270
6,878,187 B1	4/2005	Hays et al.	2006/0239831 A1	10/2006	Garris, Jr.
6,893,208 B2	5/2005	Frosini et al.	2006/0254659 A1	11/2006	Bellott et al.
6,907,933 B2	6/2005	Choi et al.	2006/0275160 A1	12/2006	Leu et al.
6,979,358 B2	12/2005	Ekker	2007/0029091 A1	2/2007	Stinessen et al.
7,001,448 B1	2/2006	West	2007/0036646 A1	2/2007	Nguyen et al.
7,013,978 B2	3/2006	Appleford et al.	2007/0051245 A1	3/2007	Yun
7,022,150 B2	4/2006	Borgstrom et al.	2007/0062374 A1	3/2007	Kolle
7,022,153 B2	4/2006	McKenzie	2007/0065317 A1	3/2007	Stock
7,025,890 B2	4/2006	Moya	2007/0084340 A1	4/2007	Dou et al.
7,033,410 B2	4/2006	Hilpert et al.	2007/0140870 A1	6/2007	Fukanuma et al.
7,033,411 B2	4/2006	Carlsson et al.	2007/0151922 A1	7/2007	Mian
7,056,363 B2	6/2006	Carlsson et al.	2007/0163215 A1	7/2007	Lagerstadt
7,063,465 B1	6/2006	Wilkes et al.	2007/0172363 A1	7/2007	Laboube et al.
7,112,036 B2	9/2006	Lubell et al.	2007/0196215 A1	8/2007	Frosini et al.
7,131,292 B2	11/2006	Ikegami et al.	2007/0227969 A1	10/2007	Dehaene et al.
7,144,226 B2	12/2006	Pugnet et al.	2007/0294986 A1	12/2007	Beetz
7,159,723 B2	1/2007	Hilpert et al.	2008/0031732 A1	2/2008	Peer et al.
7,160,518 B2	1/2007	Chen et al.	2008/0039732 A9	2/2008	Bowman
7,169,305 B2	1/2007	Gomez	2008/0246281 A1	10/2008	Agrawal et al.
7,185,447 B2	3/2007	Arbeiter	2008/0315812 A1	12/2008	Balboul
7,204,241 B2	4/2007	Thompson	2009/0013658 A1	1/2009	Borgstrom et al.
7,241,392 B2	7/2007	Maier	2009/0015012 A1	1/2009	Metzler et al.
7,244,111 B2	7/2007	Suter et al.	2009/0025562 A1	1/2009	Hallgren et al.
7,258,713 B2	8/2007	Eubank et al.	2009/0025563 A1	1/2009	Borgstrom et al.
7,270,145 B2	9/2007	Koezler	2009/0151928 A1	6/2009	Lawson

2009/0169407	A1	7/2009	Yun
2009/0173095	A1	7/2009	Bhatia et al.
2009/0266231	A1	10/2009	Franzen et al.
2009/0304496	A1	12/2009	Maier
2009/0321343	A1	12/2009	Maier
2009/0324391	A1	12/2009	Maier
2010/0007133	A1	1/2010	Maier
2010/0021292	A1	1/2010	Maier et al.
2010/0038309	A1	2/2010	Maier
2010/0043288	A1	2/2010	Wallace
2010/0043364	A1	2/2010	Curien
2010/0044966	A1	2/2010	Majot et al.
2010/0072121	A1	3/2010	Maier
2010/0074768	A1	3/2010	Maier
2010/0083690	A1	4/2010	Sato et al.
2010/0090087	A1	4/2010	Maier
2010/0143172	A1	6/2010	Sato et al.
2010/0163232	A1	7/2010	Kolle
2010/0183438	A1	7/2010	Maier et al.
2010/0239419	A1	9/2010	Maier et al.
2010/0239437	A1	9/2010	Maier
2010/0247299	A1	9/2010	Maier
2010/0257827	A1	10/2010	Lane et al.
2011/0017307	A1	1/2011	Kidd et al.
2011/0061536	A1	3/2011	Maier et al.

FOREIGN PATENT DOCUMENTS

EP	301285	10/1991
EP	1582703	10/2005
EP	2013479	1/2009
EP	7838631.5	12/2009
GB	2323639	9/1998
GB	2337561	11/1999
JP	54099206	1/1978
JP	08 068501	3/1996
JP	08-284961 A	11/1996
JP	2002 242699	8/2002
JP	3711028	10/2005
JP	2005291202	10/2005
KR	2009085521	2/2008
MX	2008012579	12/2008
WO	1995024563	9/1995
WO	200117096	3/2001
WO	2007043889	4/2007
WO	2007103248	9/2007
WO	2007120506	10/2007
WO	2008036221	3/2008
WO	2008039446	3/2008
WO	2008039491	4/2008
WO	2008039731	4/2008
WO	2008039732	4/2008
WO	2008039733	4/2008
WO	2008039734	4/2008
WO	2008036394	7/2008
WO	2009111616	9/2009
WO	2009158252	12/2009
WO	2009158253	12/2009
WO	2010083416	7/2010
WO	2010083427	7/2010
WO	2010107579	9/2010
WO	2010110992	9/2010
WO	2011034764	3/2011

OTHER PUBLICATIONS

PCT/US2007/008149 International Preliminary Report on Patentability dated Sep. 30, 2008.
PCT/US2007/008149 International Search Report and Written Opinion dated Jul. 17, 2008.
PCT/US2007/020101 International Preliminary Report on Patentability dated Apr. 2, 2009.

PCT/US2007/020101 International Search Report dated Apr. 29, 2008.
PCT/US2007/020101 Written Opinion dated Mar. 19, 2009.
PCT/US2007/020471 International Preliminary Report on Patentability dated Apr. 2, 2009.
PCT/US2007/020471 International Search Report and Written Opinion dated Apr. 1, 2008.
PCT/US2007/020659 International Preliminary Report on Patentability dated Mar. 31, 2009.
PCT/US2007/020659 International Search Report and Written Opinion dated Sep. 17, 2008.
PCT/US2007/020768 International Preliminary Report on Patentability dated Mar. 31, 2009.
PCT/US2007/020768 International Search Report and Written Opinion dated Mar. 3, 2008.
PCT/US2007/079348 International Preliminary Report on Patentability dated Mar. 31, 2009.
PCT/US2007/079348 International Search Report dated Apr. 11, 2008.
PCT/US2007/079348 Written Opinion dated Jan. 25, 2008.
PCT/US2007/079349 International Preliminary Report on Patentability dated Mar. 31, 2009.
PCT/US2007/079349 International Search Report and Written Opinion dated Apr. 2, 2008.
PCT/US2007/079350 International Preliminary Report on Patentability dated Mar. 31, 2009.
PCT/US2007/079350 International Search Report dated Jul. 17, 2008.
PCT/US2007/079350 Written Opinion dated Mar. 25, 2009.
PCT/US2007/079352 International Preliminary Report on Patentability dated Mar. 31, 2009.
PCT/US2007/079352 International Search Report and Written Opinion dated Aug. 27, 2008.
PCT/US2009/036142 International Preliminary Report on Patentability dated Sep. 16, 2010.
PCT/US2009/036142 International Search Report dated Jan. 7, 2010.
PCT/US2009/036142 Written Opinion dated May 11, 2009.
PCT/US2009/047662 International Preliminary Report on Patentability dated Jan. 13, 2011.
PCT/US2009/047662 Written Opinion dated Aug. 20, 2009.
PCT/US2010/021199 International Search Report and Written Opinion dated Mar. 22, 2010.
PCT/US2010/021199 International Preliminary Report on Patentability dated Mar. 29, 2011.
PCT/US2010/021218 International Search Report and Written Opinion dated Mar. 23, 2010.
PCT/US2010/021218 International Report on Patentability dated Feb. 2, 2011.
PCT/US2010/025650 International Search Report and Written Opinion dated Apr. 22, 2010.
PCT/US2010/025650 International Report on Patentability dated Mar. 14, 2011.
PCT/US2010/025952 International Search Report and Written Opinion dated Apr. 12, 2010.
PCT/US2010/025952 International Report on Patentability dated Mar. 14, 2011.

* cited by examiner

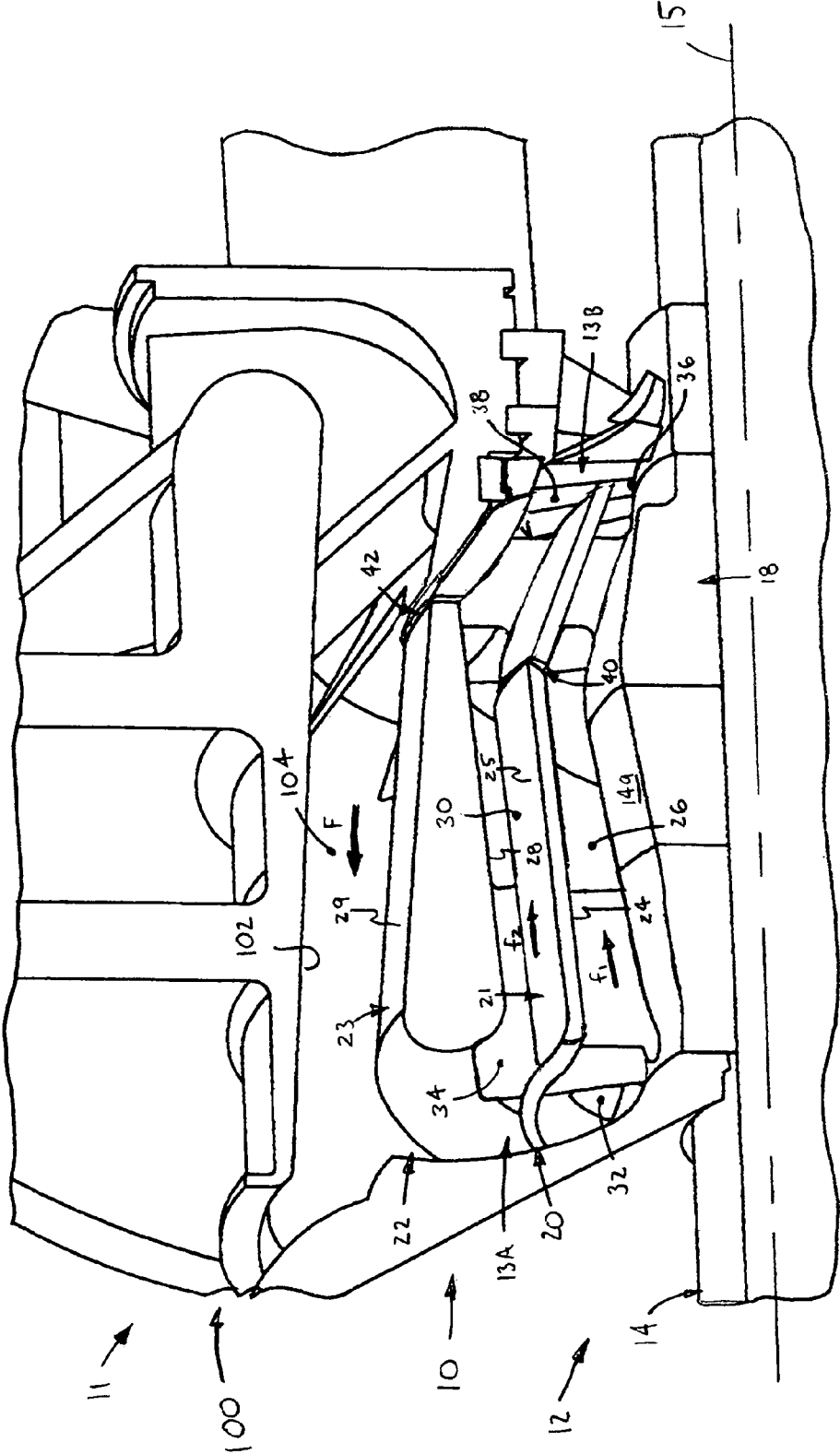

FIG. 1

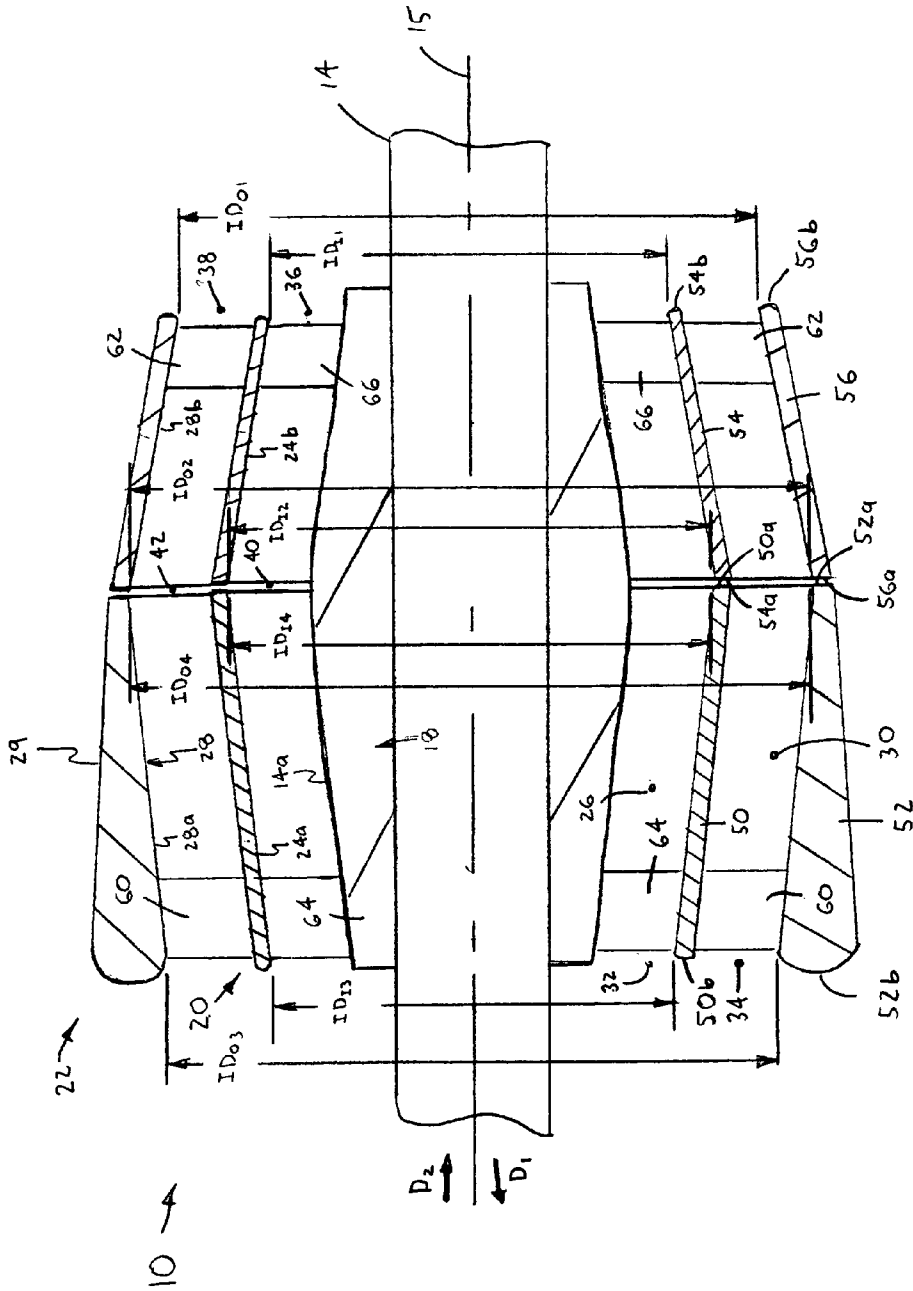

FIG. 2

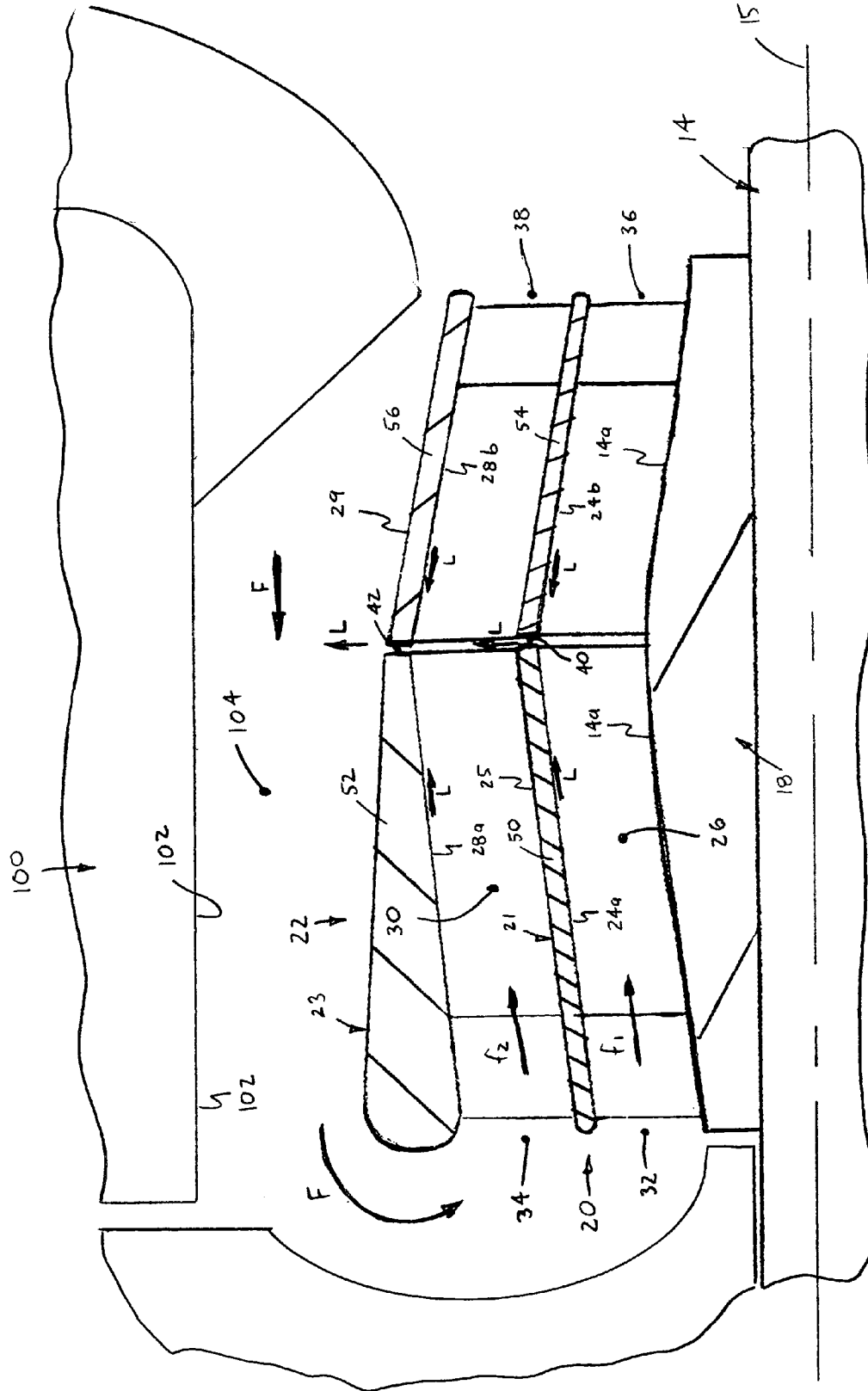

FIG. 3

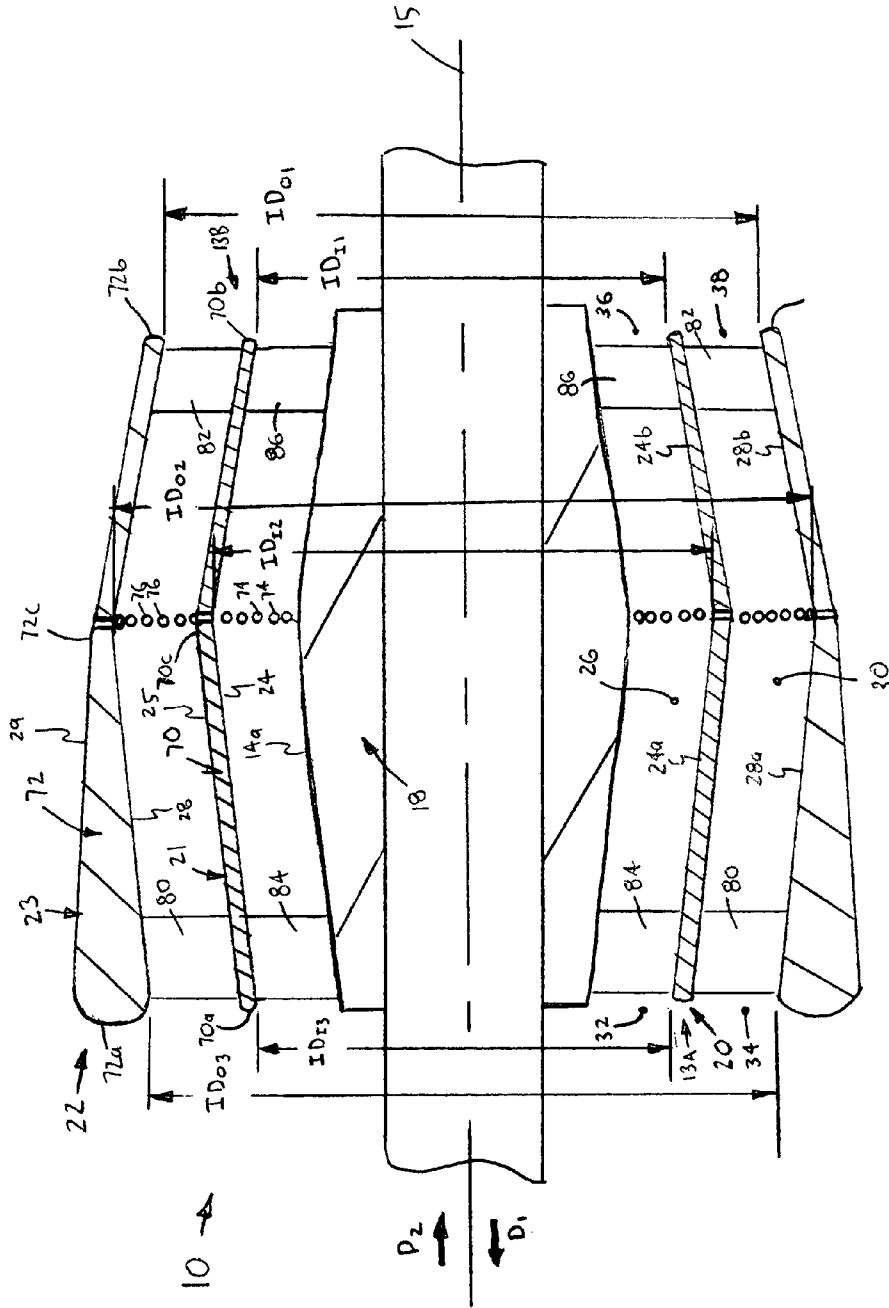

FIG 4

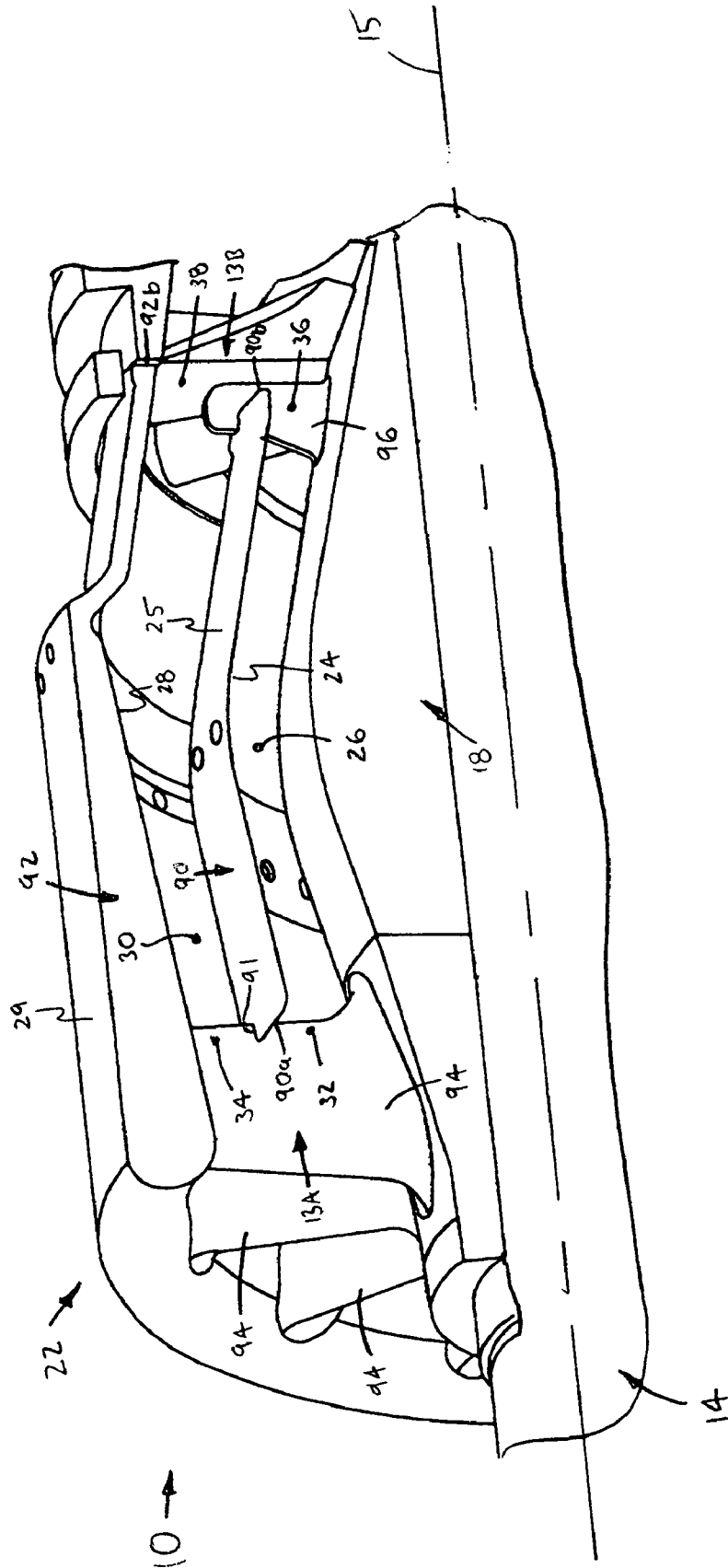

FIG. 5

1

DUAL BODY DRUM FOR ROTARY SEPARATORS

The present invention relates to fluid machinery, and more particularly to rotary separator devices.

Fluid separators are known and are generally used to separate a mixed flow (e.g., solids and fluids, liquids and gases, etc.) into different phases of fluid, fluids of varying density, and/or to separate solids from fluids. One type of rotary separator includes a generally tubular drum connected with a rotatable shaft such that a fluid passage is defined between the drum and shaft. Fluid is directed into the passage and contacts either the shaft outer surface or the drum inner surface. During such contact, liquid separates from the fluid flow, such that a substantially gaseous portion of the flow is directed for subsequent processing or use, and the liquid portions are directed for collection.

SUMMARY OF THE INVENTION

In one aspect, the present invention is a drum for a rotary separator, the separator including a shaft rotatable about a central axis. The drum comprises an inner drum member having inner and outer circumferential surfaces and being disposed generally about the shaft such that a first flow passage is generally defined between the inner drum member inner surface and the shaft. The inner drum inner surface is configured to separate liquids from a fluid flow contacting the surface. An outer drum member has inner and outer circumferential surfaces and is disposed generally about the inner drum member such that a second flow passage is generally defined between the outer drum member inner surface and the inner drum member outer surface, the second flow passage being generally coaxial with the first flow passage. The outer drum inner surface is configured to separate liquids from a fluid flow contacting the surface.

In another aspect, the present invention is a rotary separator comprising a shaft rotatable about a central axis and an inner drum member having inner and outer circumferential surfaces and being disposed generally about the shaft. As such, a first flow passage is generally defined between the inner drum member inner surface and the shaft, the inner drum inner surface being configured to separate liquids from a fluid flow contacting the surface. An outer drum member has inner and outer circumferential surfaces and is disposed generally about the inner drum member such that a second flow passage is generally defined between the outer drum member inner surface and the inner drum member outer surface. The second flow passage is generally coaxial with the first flow passage, the outer drum inner surface being configured to separate liquids from a fluid flow contacting the surface.

In a further aspect, the present invention is again a drum for a rotary separator, the separator including a shaft rotatable about a central axis. The drum comprises an inner drum member including a generally tubular body having inner and outer circumferential surfaces and an inlet. The inner member body is disposed generally about the shaft such that a first flow passage is generally defined between the inner drum member inner surface and the shaft, the inner drum inner surface being configured to separate liquids from a fluid flow contacting the surface. An outer drum member includes a generally tubular body having inner and outer circumferential surfaces and an inlet, the outer member body being disposed generally about the inner drum member. As such, a second flow passage is generally defined between the outer drum member inner surface and the inner drum member outer surface and the outer member inlet being generally disposed

2

circumferentially about the inner drum member inlet, the second flow passage is generally coaxial with the first flow passage. The outer drum inner surface is configured to separate liquids from a fluid flow contacting the surface. Further, the inner drum member inlet receives a first portion of fluid flow entering the separator and the outer drum member receives a second, remainder portion of the fluid flow.

BRIEF DESCRIPTION OF THE SEVERAL VIEWS OF THE DRAWINGS

The foregoing summary, as well as the detailed description of the preferred embodiments of the present invention, will be better understood when read in conjunction with the appended drawings. For the purpose of illustrating the invention, there is shown in the drawings, which are diagrammatic, embodiments that are presently preferred. It should be understood, however, that the present invention is not limited to the precise arrangements and instrumentalities shown. In the drawings:

FIG. 1 is a broken-away, perspective view of an axial cross-section through a separator including a drum in accordance with the present invention;

FIG. 2 is an axial cross-sectional view of a drum of the present invention in accordance with a first construction;

FIG. 3 is a broken-away, enlarged axial cross-sectional view of the separator and drum;

FIG. 4 is an axial cross-sectional view of a drum of the present invention in accordance with a second construction;

FIG. 5 is a broken-away, enlarged perspective view of an axial cross-section through a drum of the present invention in accordance with a third construction.

DETAILED DESCRIPTION OF THE INVENTION

Certain terminology is used in the following description for convenience only and is not limiting. The words "right", "left", "lower", "upper", "upward", "down" and "downward" designate directions in the drawings to which reference is made. The words "inner", "inwardly" and "outer", "outwardly" refer to directions toward and away from, respectively, a designated centerline or a geometric center of an element being described, the particular meaning being readily apparent from the context of the description. Further, as used herein, the word "connected" is intended to include direct connections between two members without any other members interposed therebetween and indirect connections between members in which one or more other members are interposed therebetween. The terminology includes the words specifically mentioned above, derivatives thereof, and words of similar import.

Referring now to the drawings in detail, wherein like numbers are used to indicate like elements throughout, there is shown in FIGS. 1-5 a drum 10 for a rotary separator 12, the separator 12 including a shaft 14 rotatable about a central axis 15 and preferably being part of a separator assembly 11. The drum 10 basically comprises an inner drum member 20 disposed about the shaft 14 and at least one "outer" drum member 22 disposed generally about the inner drum member 20, each member 20, 22 preferably including a generally tubular body 21, 23, respectively. At least one of the inner and outer drum members 20, 22 is directly connected with the shaft 14 and the other drum members 20, 22 is either connected with the one drum member 20 or 22 or with the shaft 14, as described in further detail below. As such, rotation of the shaft 14 rotates the inner and outer drum members 20, 22 about the axis 15 as a single unit.

The inner drum 20 has inner and outer circumferential surfaces 24, 25 and is spaced radially outwardly from the shaft 14 such that a first flow passage 26 is generally defined between the inner drum member inner surface 24 and an outer surface 14a of the shaft 14, preferably provided on a hub 18 mounted on the shaft 14. The inner drum inner surface 24 is configured to separate liquids from a fluid flow f_1 through the first passage 26 that contacts the surface 24. Also, the outer drum 22 has inner and outer circumferential surfaces 28, 29 and is spaced radially outwardly from the inner drum member 20. As such, a second flow passage 30 is generally defined between the outer drum member inner surface 28 and the inner drum member outer surface 25, the second flow passage 30 being generally coaxial with the first flow passage 26. Additionally, the outer drum inner surface 28 is configured to separate liquids from a fluid flow f_2 through the second passage 30 that contacts the surface 25.

Furthermore, each one of the inner and outer drum members 20, 22 has an inlet end or "inlet" 32, 34, respectively, and an outlet end or "outlet" 36, 38, respectively, spaced axially along the shaft 12 from the inlet 32, 34. As such, the two drum inlets 32, 34 define a separator inlet 13A and the two drum outlets 36, 38 define a separator outlet 13B. More specifically, the outer drum member inlet 34 is generally disposed circumferentially about the inner drum member inlet 32 and the outer drum member outlet 38 is generally disposed circumferentially about the inner drum member outlet 36, the two inlets 32, 34 and the two outlets 36, 38 thus being generally annular. With this coaxial arrangement, the inner and outer drum members 20, 22 are configured such that the inner drum member inlet 32 receives a first portion f_1 of fluid flow F entering the separator and the outer drum member inlet 34 receives a second, remainder portion f_1 of the fluid flow F.

By providing the two drum members 20, 22 and dividing the flow into two portions f_1 , f_2 , the radial extent of each passage 26, 30 is substantially lesser than a passage through a single drum sized similarly to the outer drum member 22. Further, the amount of separation surface area is substantially increased, specifically by the inner and outer surfaces 24, 25 of the inner drum member 20. Thus, the radial distance required for fluid flow to contact a rotating separation surface is substantially reduced, by approximately one-half, thereby either increasing the separation efficiency of the drum 10 or permitting the drum axial length to be reduced, in comparison with prior art "single drum" separators. Although the drum 10 is primarily described and depicted as including two (i.e., inner and outer) drum members 20, 22, the drum 10 may alternatively include three or more drum members (not depicted) so as to further increase the amount of separation surface, further reduce the radial extent of the flow passages, and/or further reduce the required axial length of the drum 10.

Still referring to FIGS. 1-5, each one of the inner and outer drum members 20, 22 further has at least one liquid outlet opening or passage 40, 42, respectively disposed generally centrally between the inlet end 32, 36, respectively, and the outlet end 34, 38, respectively. Each liquid outlet opening/passage 40, 42 extends generally radially between the drum member inner surface 24, 28, respectively, and the drum outer surface 25, 29, respectively. The outlet opening/passage 40 of the inner drum member 20 is configured to discharge liquid generally radially outwardly toward the outer drum member 22. Further, the outlet opening/passage 42 of the outer drum member 22 is configured to discharge liquid generally radially outwardly away from the drum 10, and preferably toward a static separator 100, as discussed below.

Referring particularly to FIG. 3, the inner drum member 20 is configured to direct liquid L contacting the inner drum

member 20 generally radially outwardly toward the outer drum member 22. More specifically, liquid in the first flow portion f_1 contacting the inner surface 24 of the inner drum 20 separates from the remainder of the flow portion f_1 (i.e., gaseous portion). The liquid on the inner surface 24 is directed to flow toward the inner drum liquid outlet passage 40 by a combination of the inner surface geometry (as described below) and by centrifugal forces generated by the rotating drum member 20, and is thereafter discharged from the passage 40 toward the outer drum 22. Further, liquid in the second flow portion f_2 contacting the outer surface 25 of the inner drum 20 separates from the remainder of the flow portion f_2 and is thereafter directed or "flung" radially outwardly by centrifugal force.

Further, the outer drum member 22 is configured to direct liquid L contacting the outer drum 20 generally radially outwardly away from the drum 10, and preferably toward the static separator 100 as mentioned above and described in detail below, but may alternatively flow directly to a separate collector (not depicted). Specifically, liquid in the second, outer flow portion f_2 contacting the inner surface 28 of the outer drum 22 separates from the remainder of the flow portion f_2 . Such separated liquid and liquid received from the inner drum member 20 is directed toward the liquid outlet passage 42 by a combination of the inner surface geometry (as described below) and by centrifugal forces generated by the rotating drum member 22. Thereafter, the liquid is discharged from the passage 40 outwardly from the drum 10 and toward the static separator 100. Furthermore, fluid in liquid flowing in a static passage 104, as described in second flow portion f_2 contacting the outer surface 25 of the inner drum 20 separates from the remainder of the flow portion f_2 and is thereafter directed or "flung" radially outwardly by centrifugal force.

Referring now to FIGS. 1-3, in certain constructions, the tubular body 21, 23 of each drum member 20, 22 is substantially of two-piece construction. Specifically, each one of the inner and outer drum members 20, 22 includes a first tubular body section 50, 52, respectively, and a second tubular body section 54, 56, respectively, the two body sections 50, 54 and 52, 56 of each drum member 20, 22 being spaced apart along the axis 15. Each one of the first body sections 50, 52 has an inner end 50a, 52a and an outer end 50b, 52b and each one of the second body sections 54, 56 has an inner end 54a, 56a and an outer end 54b, 56b. The outer end 50b, 52b of each one of the first tubular body sections 50, 52 provides the drum member inlet end or inlet 32, 34, respectively, and the outer end 54b, 56b of each one of the second tubular body sections 54, 56 provides the drum member outlet end/outlet 36, 38, respectively.

Further, the four body sections 50, 52, 54, 56 are arranged such each first body section inner end 50a, 52a is disposed adjacent to the inner end 54a, 56a of the associated second body section 54, 56. Preferably, the adjacent inner ends 50a, 54a of the inner drum member body sections 50, 54 are spaced apart so as to define a generally annular gap providing the inner drum member liquid outlet 40, and the adjacent inner ends 52a, 56a of the outer drum member body sections 52, 56 are spaced apart so as to define a generally annular gap providing the outer drum member liquid outlet 42. As such, the two liquid outlets 40, 42 are preferably formed as generally annular, circumferential slots. Furthermore, the four body sections are relatively sized such that the liquid outlet passage 40 of the inner drum member 20 is located generally axially proximal to the outer drum member outlet 42, such that liquid discharged from the inner drum member 20 is directed onto the outer drum 22 at least generally proximal to the outlet 42.

Additionally, an inlet section **24a, 28a** of each drum member inner surface **24, 28** is provided on the two first tubular body sections **50, 52** and an outlet section **24b, 28b** of each drum member inner surface **24, 28** is provided on the two second tubular body sections **54, 56**. At least the outlet surface sections **24b, 28b** are each preferably generally angled so as to direct liquids on the body inner surface **24, 28** toward the body section inner end **54a, 56a**, and thus away from the outlets **36, 38** and toward the liquid outlet passages **40, 42**. Specifically, each second tubular body section **54, 56** has an inside diameter ID with a first value ID_{I1}, ID_{O1} at the outer end **54b, 56b** and a second value ID_{I2}, ID_{O2} at the inner end **54a, 56a**, the second value ID_{I2}, ID_{O2} being greater than the first value ID_{I1}, ID_{O1} and the value of the diameter ID generally increasing in a first direction D_1 along the axis **15** toward the inner end **54a, 56a**. As such, the inner surface section **24b, 28b** of each second body section **54, 56** is angled radially outwardly in the first direction D_1 .

Still referring to FIGS. 1-3, the inlet surface sections **24a, 28a** are also each preferably generally angled so as to direct liquids on the body inner surface **24, 28** toward the body section inner end **50a, 52a**, and thus away from the inlets **32, 34** and toward the liquid outlet passages **40, 42**. Specifically, each second tubular body section **50, 52** has an inside diameter ID with a third value ID_{I3}, ID_{O3} at the outer end **50b, 52b** and a fourth value ID_{I4}, ID_{O4} at the inner end **50a, 52a**, the fourth value ID_{I4}, ID_{O4} being greater than the third value ID_{I3}, ID_{O3} and the value of the diameter ID generally increasing in a second, opposing direction D_2 along the axis **15** toward the inner end **50a, 52a**. Thus, the inner surface section **24a, 28a** of each first body section **50, 52** is angled radially outwardly in the second direction D_2 .

Further, with the two-piece drum member construction, the drum **10** further comprises at least one first connector **60** extending between and connecting the two first tubular body sections **50, 52** and at least one second connector **62** extending between and connecting the two second tubular body sections **54, 56**, so as to thereby couple the inner and outer drum members **20, 22**. Preferably, the drum **10** includes a plurality of the first connectors **60** disposed generally adjacent to the first body section outer ends **50b, 52b** and a plurality of the second connectors **62** disposed generally adjacent to the second body section outlet ends **54b, 56b**, both sets of connectors **60, 62** being spaced circumferentially about the axis **15**. Furthermore, the drum **10** also comprises a plurality of third connectors **64** extending between and connecting the inner drum first tubular body section **50** with the shaft **14** and plurality of fourth connectors **66** extending between and connecting the inner drum second tubular body section **54** with the shaft **14**, so as to thereby couple the inner and outer drum members **20, 22** with the shaft **14**.

Referring particularly to FIG. 4, in one alternative construction of the two drum members **20, 22**, the tubular bodies **21, 23** are formed as one-piece bodies **70, 72** that are generally similar to the two-piece construction as described in detail above, with the following differences. Each body **70, 72** has a first end **70a, 72a** providing the drum inlet **32, 34** and an opposing end **70b, 72b**, respectively, providing the drum outlet **36, 38**, respectively, with an integral central portion **70c, 72c**. Preferably, each drum tubular body **21, 23** includes one more holes **74, 76**, most preferably a plurality of holes **74, 76** spaced circumferentially about the drum axis **15**, which provide the liquid outlet passages **40, 42**.

Further, at least an outlet surface section **24b, 28b** of each drum body inner surface **24, 28** is preferably generally angled so as to direct liquids on the body inner surface **24, 28** toward the body central portion **70c, 72c**, and thus away from the outlets **36, 38** and toward the liquid outlet passages **40, 42**.

Specifically, each tubular body **70, 72** has an inside diameter ID with a first value ID_{I1}, ID_{O1} at the body second end **70b, 72b** and a second value ID_{I2}, ID_{O2} at the body central portion **21c, 23c**, the second value ID_{I2}, ID_{O2} being greater than the first value ID_{I1}, ID_{O1} and the value of the diameter ID generally increasing in a first direction D_1 along the axis **15** toward the central portion **70c, 72c**. As such, the inner surface section **24b, 28b** of each tubular body **21, 23** angled radially outwardly in the first direction D_1 .

Still referring to FIG. 4, an inlet surface section **24a, 28a** of each drum member inner surface **24, 28** are also each preferably generally angled so as to direct liquids on the body inner surface **24, 28** toward the body central portion **70c, 72c**, and thus away from the inlets **32, 34** and toward the liquid outlet passages **40, 42**. Specifically, each tubular body **70, 72** has an inside diameter ID with a third value ID_{I3}, ID_{O3} at the first end **70a, 72a**, the second value ID_{I2}, ID_{O2} being greater than the third value ID_{I3}, ID_{O3} and the value of the diameter ID generally increasing in a second, opposing direction D_2 along the axis **15** toward the body central portion **70c, 72c**. Thus, the inlet surface section **24a, 28a** of each tubular body **70, 72** is angled radially outwardly in the second direction D_2 .

Further, with the one-piece drum member construction, the drum **10** preferably further comprises at least one first connector **80** extending between and connecting the first ends **70a, 70b** of the two tubular bodies **70, 72** and at least one second connector **82** extending between and connecting the second ends **70b, 72b** of the two bodies **70, 72**, so as to thereby couple the inner and outer drum members **20, 22**. Preferably, the drum **10** includes a plurality of the first connectors **80** disposed generally adjacent to the body first ends **70a, 72a** and a plurality of the second connectors **82** disposed generally adjacent to the body second ends **70b, 72b**, both sets of connectors **80, 82** being spaced circumferentially about the axis **15**. Furthermore, the drum **10** also comprises a plurality of third connectors **84** extending between and connecting the inner drum first end **70a** with the shaft **14** and plurality of fourth connectors **86** extending between and connecting the inner drum second end **70b** with the shaft **14**, so as to thereby couple the inner and outer drum members **20, 22** with the shaft **14**. Although four sets of connectors **80, 82, 84, 86** for coupling the inner and outer drum members **20, 22** and the inner drum member **20** with the shaft **14** are preferred, the drum **10** may include only two sets of connectors, one set for coupling the two drums and another set for coupling the inner drum (or outer drum) with the shaft **14** (structure not shown).

Referring specifically to FIG. 5, in another alternative construction of the drum members **20, 22**, the two tubular drum bodies **21, 23** are once again of one-piece construction and include tubular bodies **90, 92** that are substantially similar to the bodies **70, 72**, described above, with the following differences. Preferably, the outer drum body **92** is coupled with the shaft **14** by a plurality of connectors **94** extending radially between the shaft **14** and the body inner surface **23** and spaced circumferentially about the axis **15**, which are preferably disposed adjacent to a body first end **92a**. Further, the tubular body **90** of the inner drum member **20** is retrofitably connected with the plurality of connectors **94** so as to be disposed radially between the outer drum member **22** and the shaft **14**. Specifically, a first end **90a** of the inner body member **90** has a plurality of slots **91** (only one shown) which are configured to receive a portion of a separate one of the connectors **94**. Thus, an existing one-piece drum may be retrofitted by adding the inner drum member **20** so as to form the drum **10** of the present invention.

Furthermore, the inner drum member body **90** also preferably includes one or more connectors **96** (only one shown) extend radially between a second end **90b** of the body **90b** and the shaft **14** so as to connect the second end **90b** with the shaft **14**. In the depicted structure, the second end **92b** of the outer drum member body **92** is “free” or unconnected with the shaft **14**, but may alternatively be directly attached to the shaft **14**.

Although each of the above drum constructions is preferably configured to direct liquid **L** toward the center of each drum member **20** or **22**, so as to be thereafter discharged through centrally located slots **40**, **42** or holes **74**, **76**, each drum member **20** and/or **22** may alternatively be formed so as to direct liquid **L** toward either the member inlet **32**, **34**, respectively, or/and the member outlet **36**, **38**, respectively. As such, either or both of the inner and outer drum members **20**, **22** may be formed with at least inner surfaces **24**, **28** that slope “monotonically” toward either the inlet ends **32**, **34** or the outlet ends **36**, **38**.

Referring now to FIGS. **1** and **3**, the drum **10** is preferably used with a separator assembly **11** that includes a static member **100** disposed generally about the rotary separator **12**. The static separation member **100** has a separation surface **102** extending circumferentially about and spaced radially outwardly from the outer drum member **22**. With such a static member **100**, the outer drum member **22** is configured to direct liquid at least generally radially outwardly toward the static separation surface **102**. Further, an outer flow passage **104** is defined between the outer drum member **22** and the static member **100** which is fluidly coupled with the two drum inlets **32**, **34**. As such, liquid is separated from fluid flowing through the passage **104**, either by contact with the static separation surface **102** or the outer drum member outer surface **29**, and separated liquid on the drum outer surface **29** is directed or “flung” onto the static separation surface **102** for subsequent collection and drainage.

It will be appreciated by those skilled in the art that changes could be made to the embodiments described above without departing from the broad inventive concept thereof. It is understood, therefore, that this invention is not limited to the particular embodiments disclosed, but it is intended to cover modifications within the spirit and scope of the present invention as generally defined in the appended claims.

I claim:

1. An apparatus for separating a fluid, comprising:
a shaft rotatable about a central axis;

a rotary separator drum coupled to the shaft and configured to rotate therewith, the rotary separator drum comprising:

an inner drum member having inner and outer circumferential surfaces and being disposed about the shaft such that a first flow passage is defined between the inner circumferential surface of the inner drum member and the shaft, the inner circumferential surface of the inner drum member being configured to separate liquids from a fluid flow contacting the inner circumferential surface of the inner drum member; and

an outer drum member having inner and outer circumferential surfaces and being disposed about the inner drum member such that a second flow passage is defined between the inner circumferential surface of the outer drum member and the other circumferential surface of the inner drum member, the second flow passage being coaxial with the first flow passage, the inner circumferential surface of the outer drum member being configured to separate liquids from a fluid flow contacting the outer circumferential surface of the other drum member; and

a static member in fluid communication with the rotary separator drum, the static member including a separation surface located upstream from the rotary separator drum and extending circumferentially about and spaced radially outward from the outer drum member.

2. The apparatus as recited in claim **1**, wherein each one of the inner and outer drum members has an inlet, the inlet of the outer drum member being disposed circumferentially about the inlet of the inner drum member inlet, and the inner and outer drum members are configured such that the inlet of the inner drum member receives a first portion of fluid flow entering the rotary separator drum and the outer drum member receives a second, remainder portion of the fluid flow entering the rotary separator drum.

3. The apparatus as recited in claim **1**, wherein the inner drum member is configured to direct liquid contacting the inner drum member radially outward and toward the outer drum member.

4. The apparatus as recited in claim **1**, wherein each one of the inner and outer drum members has inlet and outlet ends and at least one outlet opening disposed centrally between the inlet and outlet ends and extending radially between the inner and outer circumferential surfaces of the inner and outer drum members, the outlet opening of the inner drum member being configured discharge liquid radially outward and toward the outer drum member and the outlet opening of the outer drum member being configured to discharge liquid radially outward and away from the drum.

5. The apparatus as recited in claim **1**, wherein one of the inner and outer drum members is connected with the shaft and the other one of the inner and outer drum members is connected with one of the one drum member and the shaft such that rotation of the shaft rotates the inner and outer drum members about the central axis as a single unit.

6. The apparatus as recited in claim **1**, wherein the outer drum member is connected with the shaft by a plurality of connectors and the inner drum member is retrofittably connected with the plurality of connectors so as to be disposed radially between the outer drum member and the shaft.

7. The apparatus as recited in claim **1**, wherein each one of the inner and outer drums has an inlet end and outlet end, the two inlet ends defining a separator inlet and the two outlet ends defining a separator outlet.

8. The apparatus as recited in claim **1**, wherein each one of the inner and outer drum members includes a tubular body.

9. The apparatus as recited in claim **1**, wherein each one of the inner and outer drum members includes first and second tubular body sections spaced apart along the central axis, each one of the first and second body sections having an inner end disposed adjacent to the inner end of the other one of the first and second body sections and an opposing outer end, the outer end of each one of the first tubular body sections providing a drum member inlet end and the outer end of each one of the second tubular body sections providing a drum member outlet end.

10. The apparatus as recited in claim **9**, wherein each second tubular body section has an inside diameter with a first value at the outer end and a second value at the inner end, the second value being greater than the first value and the value of the inside diameter increasing in a first direction along the central axis toward the inner end such that an inner surface section of each second body section is angled radially outward in the first direction so that liquid contacting the inner surface section is directed away from the drum member outlet end provided by the second tubular body section.

11. The apparatus as recited in claim **10**, wherein each first tubular body section has an inside diameter with a third value

at the outer end and a fourth value at the inner end, the fourth value being greater than the third value and the value of the inside diameter increasing in a second direction along the central axis toward the inner end such that the inner surface section of each first body section is angled radially outward in the second direction so that liquid contacting an inner surface section of the first tubular body section is directed away from the drum member inlet end provided by the first body section.

12. The apparatus as recited in claim 9, wherein a liquid outlet passage is defined between the inner ends of the first and second tubular body sections of each of the inner and outer drum members.

13. The apparatus as recited in claim 12, wherein the liquid outlet passage of the inner drum member is located axially proximal to the liquid outlet passage of the outer drum member.

14. The apparatus as recited in claim 9, further comprising at least one first connector extending between and connecting the two first tubular body sections of the inner and outer drum members and at least one second connector extending between and connecting the two second tubular body sections of the inner and outer drum members.

15. The apparatus as recited in claim 1, wherein the outer drum member is configured to direct liquid radially outward toward the separation surface of the static member.

16. The apparatus as recited in claim 1, wherein:

the outer drum member has inlet and outlet ends spaced along the central axis;

the rotary separator drum further comprises first and second sets of connectors extending radially between the shaft and the outer drum member and spaced circumferentially about the central axis, the first set of connectors being located adjacent to the inlet end of the outer drum and the second set of connectors being located adjacent to the outlet end of the outer drum member; and

the inner drum member has a first end connected with at least one of the connectors of the first set of connectors and a second end connected with at least one of the connectors of the second set of connectors.

17. A separator, comprising:

a shaft rotatable about a central axis;

a rotary separator drum coupled to the shaft and configured to rotate therewith, the rotary separator drum comprising:

an inner drum member having inner and outer circumferential surfaces and being disposed about the shaft such that a first flow passage is defined between the inner circumferential surface of the inner drum member and the shaft, the inner circumferential surface of the inner drum member being configured to separate liquids from a fluid flow contacting the inner circumferential surface of the inner drum member; and

an outer drum member having inner and outer circumferential surfaces and being disposed about the inner drum member such that a second flow passage is defined between the inner circumferential surface of the outer drum member and the outer circumferential surface of the inner drum member, the second flow passage being coaxial with the first flow passage, the inner circumferential surface of the outer drum member being configured to separate liquids from a fluid flow contacting the inner circumferential surface of the outer drum member; and

a static member in fluid communication with the rotary separator drum, the static member including a separation surface located upstream from the rotary separator drum and extending circumferentially about and spaced radially outward from the outer drum member.

18. The separator as recited in claim 17, wherein each one of the inner and outer drum members has an inlet, the inlet of the outer drum being disposed circumferentially about the inlet of the inner drum member, and the inner and outer drum members are configured such that the inlet of the inner drum member receives a first portion of fluid flow entering the rotary separator drum and the outer drum member receives a second, remainder portion of the fluid flow of fluid flow entering the rotary separator drum.

19. The separator as recited in claim 17, wherein one of the inner and outer drum members is connected with the shaft and the other one of the inner and outer drum members is connected with one of the one drum member and the shaft such that rotation of the shaft rotates the inner and outer drum members about the central axis as a single unit.

20. A separator, comprising:

a shaft rotatable about a central axis;

a rotary separator drum coupled to the shaft and configured to rotate therewith, the rotary separator comprising:

an inner drum member including a tubular body having inner and outer circumferential surfaces and an inlet, the tubular body of the inner drum member being disposed about the shaft such that a first flow passage is defined between the inner circumferential surface of the inner drum member and the shaft, the inner circumferential surface of the inner drum member being configured to separate liquids from a fluid flow contacting the inner circumferential surface of the inner drum member; and

an outer drum member including a tubular body having inner and outer circumferential surfaces and an inlet, the tubular body of the outer drum member being disposed about the inner drum member such that a second flow passage is defined between the inner circumferential surface of the outer drum member and the outer circumferential surface of the inner drum member and the inlet of the outer member being disposed circumferentially about the inlet of the inner drum member, the second flow passage being coaxial with the first flow passage, the inner circumferential surface of the outer drum member being configured to separate liquids from a fluid flow contacting the inner circumferential surface of the other drum member, wherein the first flow passage receives a first portion of fluid flow entering the rotary separator drum and the second flow passage receives a second, remainder portion of the fluid flow; and

a static member in fluid communication with the rotary separator drum, the static member including a separation surface located upstream from the rotary separator drum and extending circumferentially about and spaced radially outward from the outer drum member.

21. The apparatus as recited in claim 1, wherein the separation surface of the static member and the outer circumferential surface of the outer drum member define a static separation zone therebetween.

22. The apparatus as recited in claim 21, wherein the static separation zone is configured so that fluid proceeds there-through in a second axial direction and is turned to a first axial direction prior to entering the rotary separator drum.

23. The apparatus as recited in claim 21, wherein the separation surface and the rotary separator drum define a turn therebetween such that a fluid flow direction through the separation zone is turned from a second axial direction to a radial inward direction and then to a first axial direction, prior to entry into the rotary separator drum.