

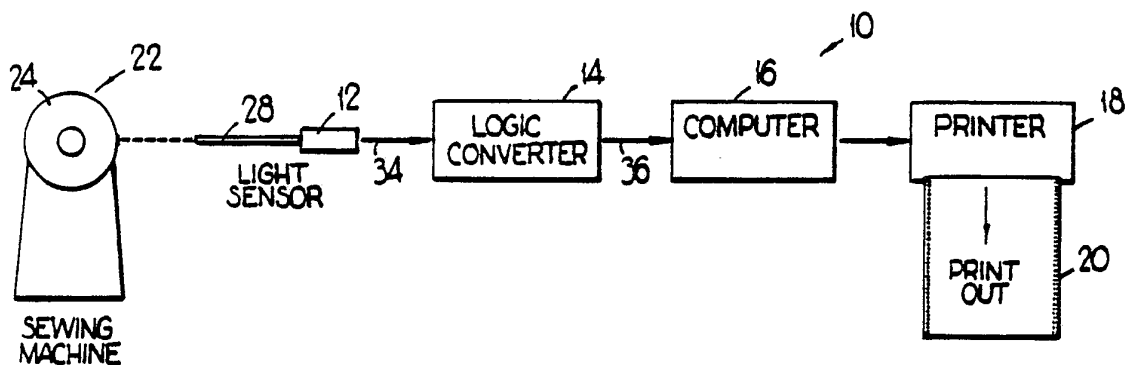

INTERNATIONAL APPLICATION PUBLISHED UNDER THE PATENT COOPERATION TREATY (PCT)

<p>(51) International Patent Classification⁴ : G01L 3/26</p>	<p>A1</p>	<p>(11) International Publication Number: WO 88/ 01048 (43) International Publication Date: 11 February 1988 (11.02.88)</p>
<p>(21) International Application Number: PCT/US87/01831 (22) International Filing Date: 29 July 1987 (29.07.87) (31) Priority Application Number: 891,453 (32) Priority Date: 30 July 1986 (30.07.86) (33) Priority Country: US (71)(72) Applicant and Inventor: TEW, Jerry, Jerome [US/US]; 408 Mavrick Drive, Dothan, AL 36301 (US). (74) Agent: HOPKINS, George, M.; Hurt, Richardson, Garner, Todd & Cadenhead, 1400 Peachtree Place Tower, 999 Peachtree Street, NE, Atlanta, GA 30309-3999 (US).</p>		<p>(81) Designated States: AT (European patent), AU, BE (European patent), CH (European patent), DE (European patent), FR (European patent), GB (European patent), IT (European patent), JP, KR, LU (European patent), NL (European patent), SE (European patent). Published <i>With international search report.</i></p>

(54) Title: EFFICIENCY MONITORING DEVICE



(57) Abstract

An efficiency monitoring device determines the efficiency of a machine (22) and operator where the machine (22) is turned off and on by the operator. Efficiency is determined by first monitoring the cycle speed of a machine (22) by means of a light source (28), a reflective tape (26), and a photoelectric cell (12) which produces a signal from which a digital computer (16) can continuously calculate the instantaneous cycle speed. The computer (16) maintains a continuous time base, and then plots the cycle speed as a function of time to produce an efficiency profile for the machine and operator.

FOR THE PURPOSES OF INFORMATION ONLY

Codes used to identify States party to the PCT on the front pages of pamphlets publishing international applications under the PCT.

AT	Austria	FR	France	ML	Mali
AU	Australia	GA	Gabon	MR	Mauritania
BB	Barbados	GB	United Kingdom	MW	Malawi
BE	Belgium	HU	Hungary	NL	Netherlands
BG	Bulgaria	IT	Italy	NO	Norway
BJ	Benin	JP	Japan	RO	Romania
BR	Brazil	KP	Democratic People's Republic of Korea	SD	Sudan
CF	Central African Republic	KR	Republic of Korea	SE	Sweden
CG	Congo	LI	Liechtenstein	SN	Senegal
CH	Switzerland	LK	Sri Lanka	SU	Soviet Union
CM	Cameroon	LU	Luxembourg	TD	Chad
DE	Germany, Federal Republic of	MC	Monaco	TG	Togo
DK	Denmark	MG	Madagascar	US	United States of America
FI	Finland				

- 1 -

EFFICIENCY MONITORING DEVICEBACKGROUND OF THE INVENTION

This invention relates generally to efficiency monitoring devices for machine operators, and more particularly concerns an efficiency
5 monitoring device for a sewing machine operator which produces a work versus time profile for the machine operator and machine being monitored.

In the garment industry, it is common to have garment manufacturing facilities in which a
10 large number of workers produces garments using standard commercial sewing machines. In order to control costs, it is also common to reimburse such workers on a per-piece basis. In that manner, a manufacturer can predict the per-piece cost
15 associated with each garment being manufactured in a predictable fashion. Such remuneration system also rewards the efficient worker who is able to produce a large number of piece goods in a short period of time.

Even though workers in such facilities are
20 generally paid on a per-piece basis, their pay on a per-piece basis must rise to the level of the minimum hourly wage required by federal law. Consequently, if an inefficient operator does not sew enough piece goods together in order to meet the minimum wage
25 requirements, the manufacturer will have to supplement that worker's pay, thereby increasing the per-piece cost of the goods produced. In the past, such inefficient workers were simply terminated. Such a practice, not only created hardship for the
30 worker, but also increased the manufacturer's costs because of the additional costs involved in recruiting and training new workers.

- 2 -

In addition, even workers who were able to achieve the minimum wage standard on a per-piece basis sometimes, even though they appear willing and able to generate higher income, were not able to do so for reasons unknown to them or perhaps even to their supervisors.

In order to overcome the difficulties involved with inefficient workers including the additional cost to the manufacturer and to assist workers in increasing their productivity both to the benefit of the manufacturer and to themselves, it is necessary to be able to know on a time basis what it is that an operator is doing. Particularly, once the garment is properly positioned for stitching, it is important that the machine operator accelerate the sewing machine to the highest possible speed to complete the stitching operation before stopping and repositioning of the garment is undertaken. While some workers may appear to be very swift in their ability to reposition and prepare a garment for stitching during each operation, they may lose efficiency because they simply do not accelerate the sewing machine to the highest possible speed for the particular operation. In the past, such problems have been detected by supervisors who simply listened to the hum of the machine to determine which operators are working at highest efficiency and which are not. Such a practice, by its very description, suggests problems. Therefore, it is important to be able to analytically evaluate and graphically display a worker's efficiency in operating a sewing machine.

SUMMARY OF THE INVENTION

It is therefore an object of the present invention to provide an efficiency monitoring device for monitoring the work output of a sewing machine

- 3 -

operator over both a full working shift and also over shorter time periods relating to the completion of specific assigned tasks.

The foregoing object is accomplished by
5 monitoring the speed of the operator's sewing machine, expressed as stitches per unit time, over a time base which can be either expanded or contracted for ease of analysis for the time of interest. In order to monitor the speed of a sewing machine, it is
10 necessary to count the revolutions of the sewing machine without the necessity of attaching complicated mechanical or electromechanical transmissions to the handwheel and thereby obstructing the operator's ability to use the
15 handwheel. It is also important that the monitoring device be essentially portable so that it can be moved from machine to machine in order to allow the greatest flexibility in monitoring the overall operations within a particular facility.

20 Consequently, the present invention provides for monitoring the revolutions of the handwheel of a sewing machine by means of an infra-red detector switch in combination with a piece of reflective tape simply attached to the handwheel. A small piece of
25 tape on the handwheel does not affect the operator's ability to operate the machine, and the infra-red sensing switch can be located adjacent the wheel in a position which will also avoid any problems associated with obstructing the operation of the
30 handwheel.

The output of the infra-red sensing switch is connected to a logic circuit which in turn produces an ASCII character for each revolution of the handwheel. The ASCII character is then connected
35 to a small portable computer which counts the number of stitches per unit time for each incremental time

- 4 -

unit of interest and then displays the results in a profile showing the speed of the machine as a function of the time interval of interest. The resulting profile may have its time interval of interest either expanded or contracted in order to show a full day's shift or a more specific time interval relating to the carrying out of a specific sewing operation. The profile allows a supervisor to simply scan the chart in order to make rapid and immediate comparisons between an efficient worker and an inefficient worker and to discover quickly certain problems that may cause an inefficient worker to be less efficient than a more efficient worker.

Other objects and advantages of the invention will become apparent upon reading the following detailed description and upon reference to the drawings.

BRIEF DESCRIPTION OF THE DRAWINGS

Figure 1 is a perspective view showing a standard sewing machine with the infra-red sensor and reflective tape strip attached;

Fig. 2 is a block diagram for the efficiency monitoring device of the present invention;

Fig. 3 is an electrical schematic for the logic converter used in connection with the present invention;

Fig. 4 is a graph displaying a work versus time profile of a fictitious worker (Mary Smith) showing work efficiency for an entire work shift; and

Fig. 5 is a graph displaying a work versus time profile of a fictitious worker (Fannie Scott) in which the time scale has been expanded to show the work efficiency for a particular task.

35

- 5 -

DETAILED DESCRIPTION OF THE INVENTION

While the invention will be described in connection with a preferred embodiment, it will be understood that I do not intend to limit the invention to that embodiment. On the contrary, I intend to cover all alternatives, modifications, and equivalents as may be included within the spirit and scope of the invention as defined by the appended claims.

Turning first to Figure 2, there is shown a block diagram of the efficiency monitoring device 10 of the present invention for monitoring the efficiency of an operator of sewing machine 22. The monitoring device includes a light sensor 12, a logic converter 14, and a multi-purpose digital computer 16 which is connected to a standard printer 18 to produce a print-out 20.

In order to judge the efficiency of the operator of sewing machine 22, it is necessary to monitor the instantaneous speed in stitches per minute of the sewing machine 22 and display that speed as a function of time. In order to determine the instantaneous speed of the sewing machine 22 it is necessary to count the revolutions of the handwheel 24. Each revolution of the handwheel 24 produces a single stitch.

In order to detect the number of revolutions of the handwheel 24, a piece of reflective tape 26 (Figure 1) is attached to an exposed surface of the handwheel 24 of the sewing machine 22. The light sensor 12 has a probe 28 which is aimed at the handwheel and directs a red or infra-red light source toward the handwheel. Each time the reflective tape 26 passes the light source from the light sensor 12, the light is reflected back and a photoelectric cell

- 6 -

in the light sensor 12 senses the reflected light from the tape and produces a signal on line 34.

As shown in Figure 1, the light sensor 12 can be mounted on any suitable support mechanism such as 30 which is attached to base 32 supporting the sewing machine 22. It should also be noted that the light sensor 12 with its probe 28 is not physically attached to the handwheel 24 so that the light sensor does not impair the operator's ability to grasp and move the handwheel as necessary during sewing operations. In fact, the light sensor can be displaced from the reflective tape as much as 0.40 inch to ensure there will be no interference with the operation of the handwheel.

The light sensor 12 is preferably an FE7B sub-miniature fiber optic photoelectric control manufactured by Micro Switch of Freeport, Illinois. The probe 28 may be bent to a maximum bend radius of 0.40 inch in order to accommodate the end of the probe to the particular application. While Figure 1 shows a standard sewing machine with the handwheel exposed above the base 32, other commercial sewing machines may have the handwheel mounted below the base with access only through a hole in the base. Consequently, the flexible probe 28 provides substantial advantages in monitoring the speed of the handwheel where access is limited. The Micro Switch light sensor 12 is available either with a visible red or invisible infra-red light source. The infra-red light source sensor is generally considered more stable when sensing a wide variety of colors. The light sensor operates on voltages of 10-28 volts DC and provides a current sink output of up to 100 milleamps. In the particular application of the present invention, an infra-red light is used, and the mode of operation is light operated, that is the

- 7 -

output is energized when the reflecting tape is presented in line with the probe 28. In operation the light source is optically transmitted by means of fiber optic filaments to the end of the probe. When
5 the light strikes the reflective tape, the reflected light is sensed by a photoelectric cell in the sensor which in turn generates the electrical signal on line 34.

The reflective tape used is a standard
10 reflective tape used in highway markers and other similar applications.

The logic converter 14 receives the light operated output signal on line 34 from the light sensor 12. The logic converter 14 receives that
15 negative going signal (from +5 volts to 0 volts) and converts it into a single ASCII character which is presented in real time on output line 36 to the digital computer 16.

Turning to Figure 3 there is shown an
20 electric schematic of the logic converter 14. The logic converter 14 includes a power supply 40 of conventional design which converts standard a.c. current on lines 42 and 44 to a regulated +5 volts d.c. on line 46, +12 volts d.c. on line 48, and -12
25 volts d.c. on line 50. A metal oxide varistor 52 is connected across the a.c. line 42 and 44 to protect the power supply from voltage spikes. The a.c. current on lines 42 and 44 is stepped down to 24
30 volts a.c. by a center grounded transformer 54. The 24 volt a.c. current on lines 55 and 57 is then rectified to an unregulated d.c. voltage by means of full wave rectifier 56. The full wave rectifier 56 produces unregulated positive voltage on line 58 and an unregulated negative voltage on line 60 both with
35 respect to ground on line 62. The unregulated positive d.c. voltage on line 58 is fed to regulators

- 8 -

64 and 66 which produce a regulated +5 d.c. voltage on line 46 and a regulated +12 d.c. voltage on line 48 respectively. The negative unregulated voltage on line 60 is fed to regulator 68 which produces a
5 regulated -12 d.c. voltage on line 50. The regulators 64, 66, and 68 are conventional in design and are generally contained in a single solid state chip. The +12 d.c. voltage on line 48 along with the ground on line 62 are connected via lines 70 and 72
10 to the light sensor 12 to power the light sensor circuitry.

The logic converter 14 includes input pulse shaper circuit 76 which receives the negative going pulse (+5 volts to 0 volts) on line 34 from the light
15 sensor 12. The pulse shaper 76 is an integrated circuit which contains four nand Schmidt triggers. One of the Schmidt triggers, having its output connected to line 78, is triggered by the negative going pulse on line 36 and produces a predictable
20 duration positive going pulse on line 78 which is in turn connected to the clock input of ASCII character generator 80.

The character generator 80 is a conventional ASCII character generator which produces any one of
25 256 ASCII characters on output line 82. In connection with the present invention, it is not necessary that any particular ASCII character be generated as long as the computer 16 is programed to simply recognize the absence or presence of any ASCII
30 character. Therefore, the ASCII character generator 80 has most of its logic inputs connected together in order to ensure that the character generator is not falsely triggered by interference and consistently puts out an ASCII character for each incoming pulse
35 from the light sensor.

- 9 -

The output signal from the ASCII character generator appears on line 82 which is connected to a second Schmidt trigger contained within pulse shaper 76. The output of the second Schmidt trigger on line 5 84 is connected through an optical isolator circuit 86 to isolate the input on line 84 from the output line 88. Output line 88 is in turn connected through resistor 90 to output line 36. The output on line 36 is thus a serially represented ASCII character which 10 can be then transmitted to the computer for further analysis.

In addition, the logic converter 14 has a delay blocking circuit 92 which is a simple time delay circuit connected to an inhibit input 94 of the 15 ASCII character generator 80 which serves to inhibit the output of an ASCII character. Depending on the time delay, the logic converter may be adjusted to produce an ASCII character for every pulse, every other pulse, every third pulse, every fourth pulse, 20 etc. from the light sensor depending on the speed of the sewing machine and the time frame over which the sewing machine is being monitored. It is preferable, that the delay circuit 92 not be used and that an ASCII character be produced for every pulse received 25 from the light sensor for the greatest degree of accuracy.

Once the ASCII character is produced on line 36, it is connected to a standard multi-purpose digital computer 16 which is preferably a personal 30 computer, that is small and highly portable. Such a personal computer can easily be programmed by a person of ordinary skill in the art to count the number of ASCII characters generated over a particular short time frame to produce an 35 instantaneous cycle speed for the sewing machine when the sewing machine is on which cycle speed can then

- 10 -

be displayed as numbers of stitches per minute. The computer 16 also has a clock for establishing a continuous time coordinate so that, as the instantaneous speed varies over time, the speed of the machine can be displayed as a graph having the speed of the machine as the ordinate and the monitored time frame as the abscissa. The computer can be programmed to store the information received over time to be printed out at a later time for analysis or the printout can be generated in real time. In addition, the computer can be programmed to provide a printout in which the time scale along the abscissa is divided into increments of several minutes over the entire work shift of a day thereby showing the productivity of the worker over an entire shift. Alternatively, the time reference along the abscissa may be divided into shorter increments of several seconds in order to graphically show the operator's efficiency when carrying out specific operations over shorter periods of time.

Figure 4 shows a typical printout 20 for a fictitious worker, Mary Smith, in which the time axis (abscissa) 102 is divided into increments of several minutes extending over the course of an entire work shift 7:45 to 14:57 (24-hour clock). The ordinate 100 is divided into hundreds of stitches per minute. It should be noted that for the particular machine being used by Mary Smith, the maximum speed is 4,400 stitches per minute. A quick scan of the chart shows that Mary Smith is not a particularly efficient operator in that her machine never tops 800 stitches/minute or about one-fifth the maximum machine speed. On the other hand, it can be readily appreciated that Mary Smith works fairly constantly during the course of the day taking time out from her work only during what appear to be apparent breaks

- 11 -

for coffee around 9:00, for lunch around 11:45 and
for an afternoon break around 14:00. Consequently,
one would conclude that Mary Smith would be the kind
of worker who, while apparently a diligent worker,
5 would not be nearly realizing her full potential in
terms of producing piece goods. The profile allows
the supervisor to show Mary Smith why she is not
producing piece goods as fast as other workers and
thereby maximizing her income. Training of Mary
10 Smith would then focus on trying to increase her
machine speed so that her output would be maximized.

Turning to Figure 5, there is shown a
profile for another fictitious worker, Fannie Scott,
while she is joining shoulders on a garment. The
15 sewing machine has a maximum speed of 5621 stitches
per minute. The ordinate 104 is divided into
hundreds of stitches per minute, and the abscissa is
divided into second increments for a minute.

The profile in Figure 5 of Fannie Scott
20 shows that she is remarkably better than Mary Smith
in machine speed with all speeds between 2,000 and
5,000 stitches per minute. The expanded time scale
on the abscissa, while not comparable to the profile
of Figure 4 (Mary Smith's) allows a supervisor to
25 determine the nature of the sewing time lost during
repositioning of the garment. Where there are large
time losses for every operator, for example, revised
handling procedures may be instituted to improve the
efficiency of all workers. Alternatively where one
30 worker shows excessive repositioning time losses,
that worker may be transferred to a different sewing
operation where she is more efficient.

- 12 -

I claim:

1. A device for monitoring the efficiency of operations of a machine having an on time during which the a member on machine rotates at a cycle speed, and an off time, the device comprising:
 - a. a clock for establishing a continuous time coordinate;
 - b. a sensor for sensing the cycle speed of the machine during the on time; and
 - 10 c. plotting means for creating a profile of the cycle speed as a function of the continuous time coordinate.
2. The device of claim 1, wherein the sensor includes a light source and photoelectric cell
15 which monitors the cycle speed of the machine by means of a reflective piece on the member for reflecting light from the light source back to the photoelectric cell.
3. The device of claim 1, wherein the
20 continuous time coordinate may be expanded or contracted on the profile.

1/12

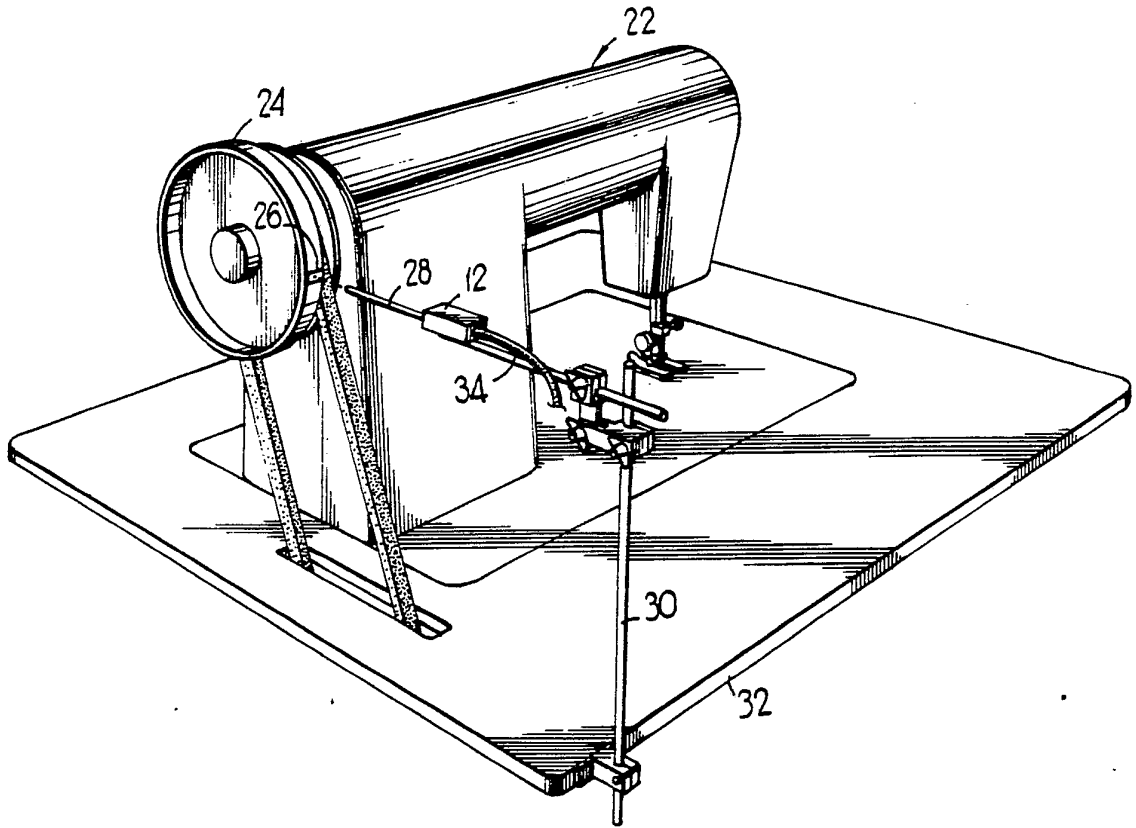

FIG 1

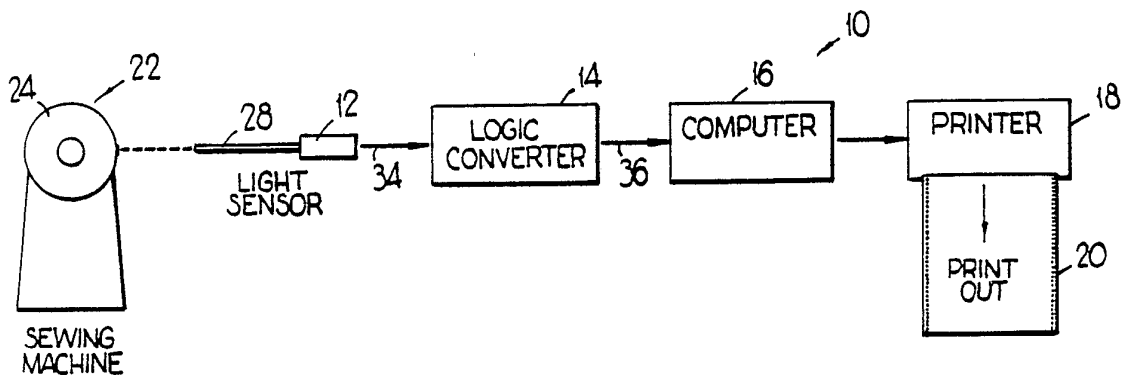
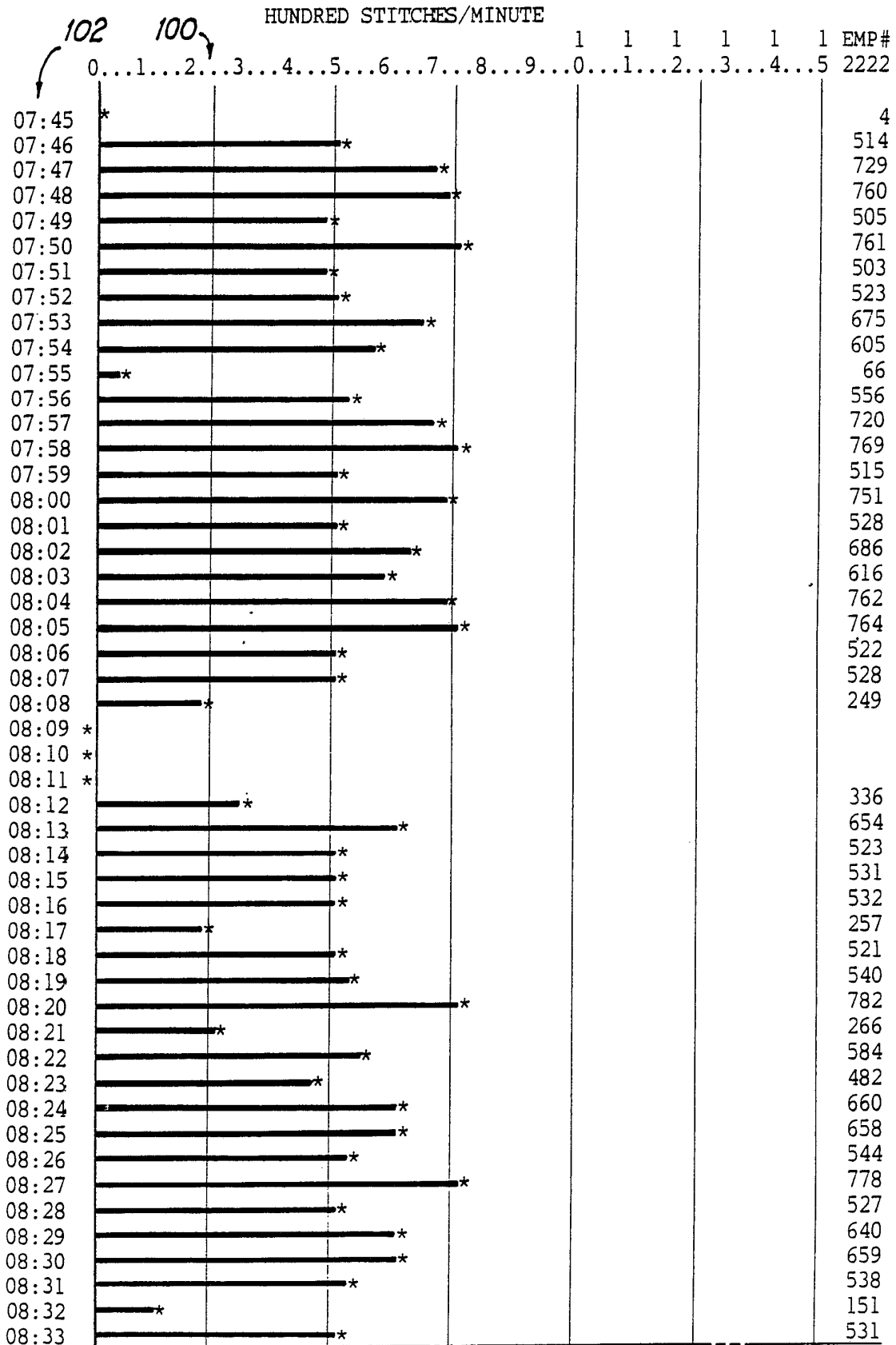

FIG 2

3/12

OPERATOR NAME = MARY SMITH
EMPLOYEE # = 2222
JOB NAME = DOUBLE NEEDLE SET SLEEVE
STUDY DATE = 04-14-1986

MACHINE SPEED = 4400



Match line to Fig 4B

FIG 4A

Match line to Fig 4A ↗

08:34	*	650
08:35	*	672
08:36	*	539
08:37	*	759
08:38	*	530
08:39	*	141
08:40	*	337
08:41	*	711
08:42	*	520
08:43	*	274
08:44	*	
08:45	*	
08:46	*	544
08:47	*	731
08:48	*	572
08:49	*	794
08:50	*	529
08:51	*	778
08:52	*	605
08:53	*	731
08:54	*	771
08:55	*	535
08:56	*	1
08:57	*	729
08:58	*	322
08:59	*	638
09:00	*	665
09:01	*	752
09:02	*	497
09:03	*	449
09:04	*	577
09:05	*	556
09:06	*	777
09:07	*	537
09:08	*	242
09:09	*	
09:10	*	
09:11	*	
09:12	*	
09:13	*	
09:14	*	
09:15	*	
09:16	*	
09:17	*	540
09:18	*	274
09:19	*	
09:20	*	
09:21	*	496
09:22	*	494
09:23	*	489
09:24	*	735
09:25	*	633
09:26	*	596
09:27	*	500
09:28	*	730
09:29	*	510
09:30	*	267

Match line to Fig 4C ↘

FIG 4B

5/12

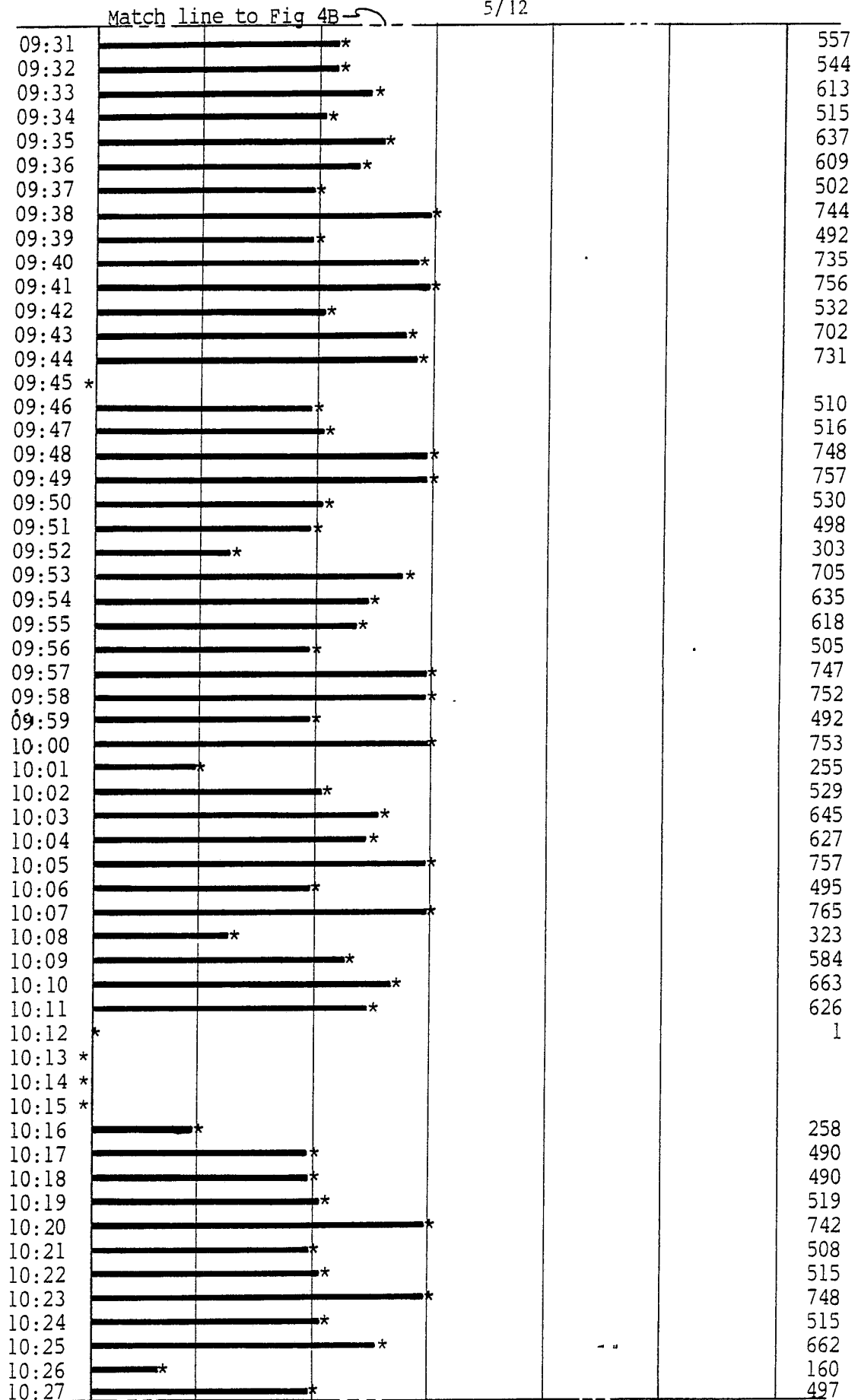

Match line to Fig 4D →

FIG 4C

Match line to Fig 4C →

10:28	*				519
10:29		*			707
10:30		*			561
10:31		*			700
10:32		*			571
10:33		*			502
10:34		*			536
10:35		*			512
10:36		*			760
10:37		*			539
10:38		*			745
10:39		*			527
10:40		*			756
10:41		*		*	776
10:42		*			518
10:43	*				
10:44	*				
10:45		*			118
10:46		*		*	642
10:47		*			299
10:48		*		*	537
10:49		*		*	758
10:50		*		*	553
10:51		*		*	789
10:52		*		*	529
10:53		*		*	786
10:54		*		*	532
10:55		*		*	685
10:56		*		*	545
10:57		*		*	659
10:58		*		*	670
10:59		*		*	641
11:00		*		*	786
11:01		*		*	529
11:02		*		*	531
11:03		*		*	517
11:04		*		*	632
11:05		*		*	652
11:06		*		*	685
11:07		*		*	622
11:08	*				
11:09	*				
11:10		*			173
11:11		*		*	537
11:12		*		*	527
11:13		*		*	800
11:14		*		*	534
11:15		*		*	777
11:16		*		*	540
11:17		*		*	755
11:18		*		*	538
11:19		*		*	671
11:20		*		*	314
11:21	*				
11:22	*				15
11:23		*		*	526
11:24		*		*	760

Match line to Fig 4E ↗

FIG 4D

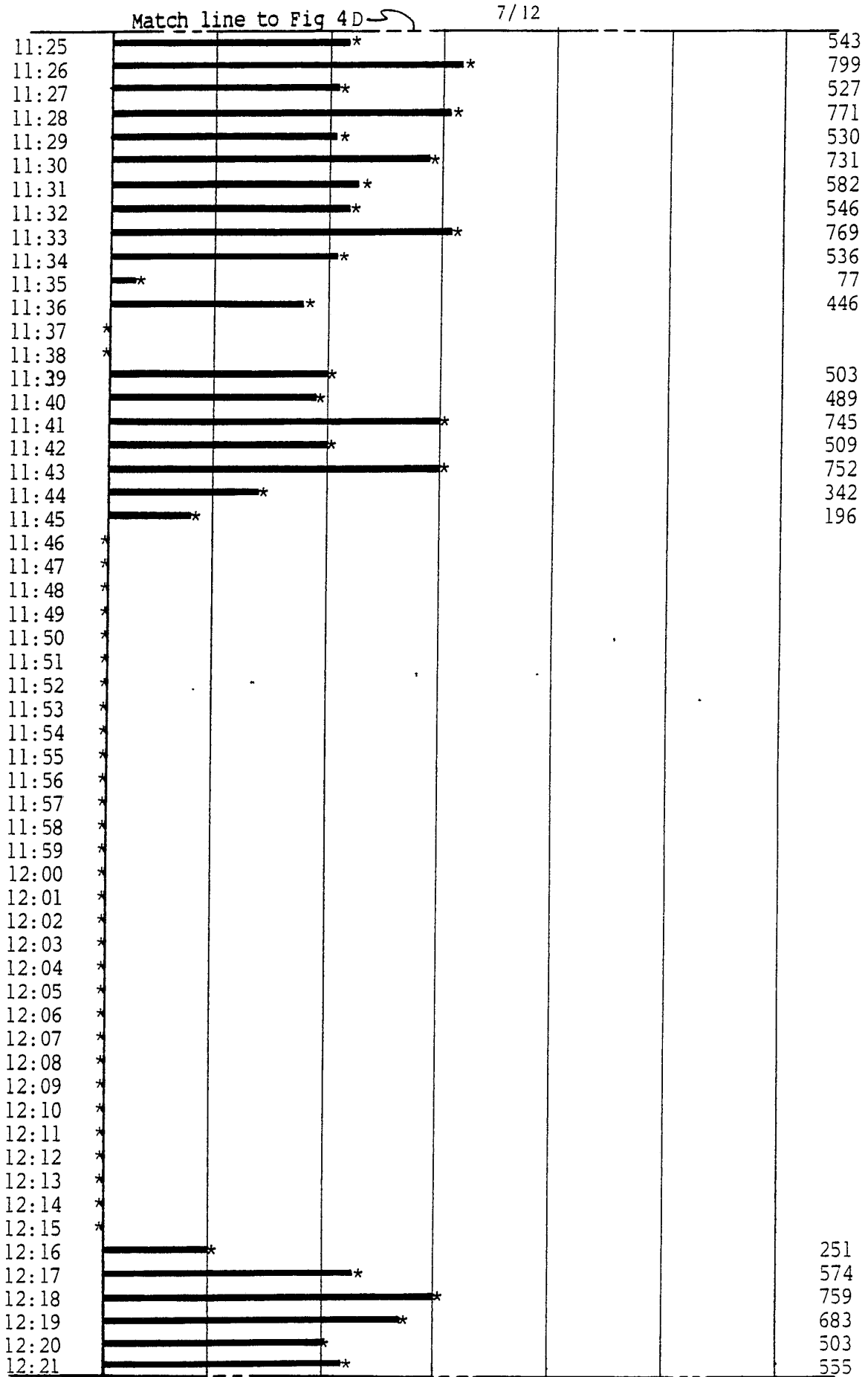

FIG 4E

Match line to Fig 4E

8/12

12:22		*				711
12:23		*				358
12:24		*				666
12:25		*				637
12:26		*				630
12:27		*				530
12:28		*				758
12:29		*				515
12:30		*				527
12:31		*				748
12:32		*				773
12:33		*				505
12:34		*				503
12:35		*				500
12:36	*					
12:37	*					
12:38	*					
12:39		*				535
12:40		*				549
12:41		*				535
12:42		*				646
12:43		*				331
12:44		*				781
12:45		*				528
12:46		*				781
12:47		*				529
12:48		*				543
12:49		*				687
12:50		*				639
12:51		*				529
12:52		*				674
12:53		*				640
12:54		*				670
12:55		*				656
12:56		*				532
12:57		*				544
12:58		*				552
12:59		*				759
13:00		*				542
13:01		*				799
13:02	*					
13:03	*					
13:04		*				250
13:05		*				539
13:06		*				514
13:07		*				787
13:08		*				533
13:09		*				651
13:10		*				159
13:11		*				528
13:12		*				702
13:13		*				594
13:14		*				683
13:15		*				508
13:16		*				384
13:17		*				783
13:18		*				532

Match line to Fig 4G

FIG 4F

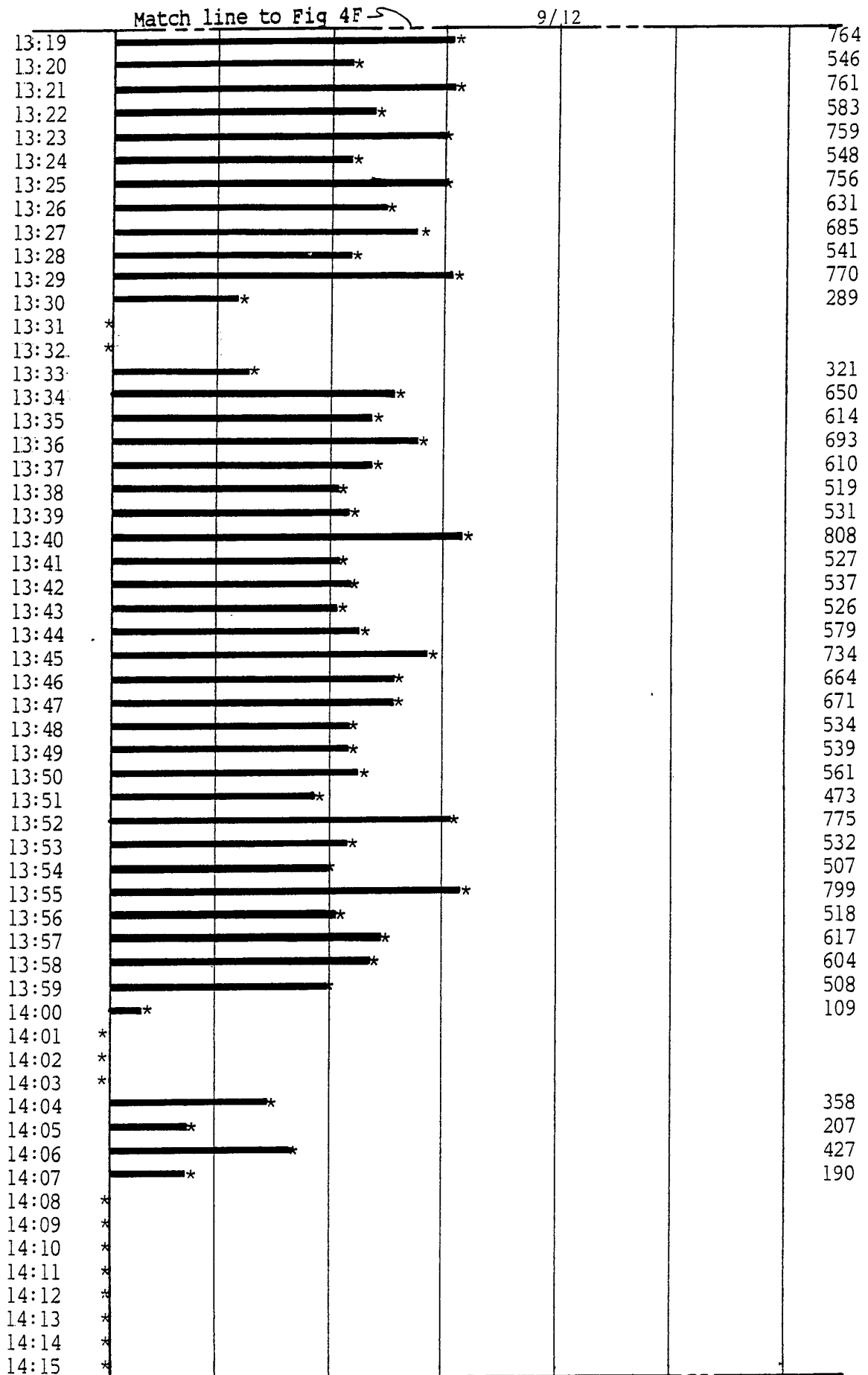

Match line to Fig 4H →

FIG 4G

SUBSTITUTE SHEET

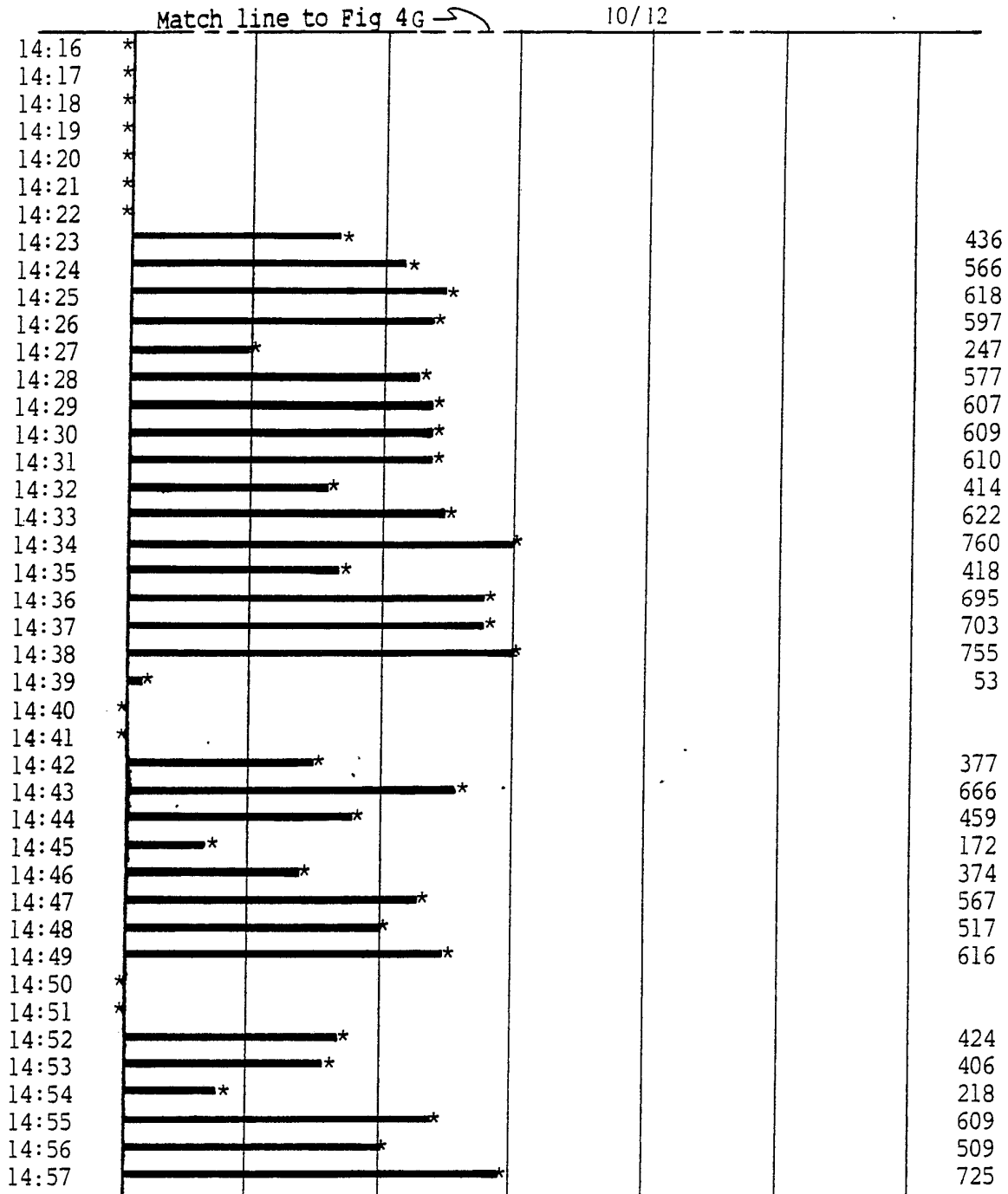

FIG 4H

Match line to Fig 5A →

10:39:27*						0
10:39:28*						0
10:39:29*						0
10:39:30*						0
10:39:31*						0
10:39:32*						0
10:39:33*						0
10:39:34 ==* 1st shld						4
10:39:35	=====*					51
10:39:36	=====*					39
10:39:37*						0
10:39:38*						0
10:39:39*						0
10:39:40*						0
10:39:41 ==* 2nd shld						6
10:39:42	=====*					82
10:39:43*						0

END PRINT TIME 07:58:06

FIG 5B

INTERNATIONAL SEARCH REPORT

International Application No PCT/US87/01831

I. CLASSIFICATION OF SUBJECT MATTER (if several classification symbols apply, indicate all) ³		
According to International Patent Classification (IPC) or to both National Classification and IPC		
INT. CL. ⁴ G01L 3/26		
U.S. CL. 73/112		
II. FIELDS SEARCHED		
Minimum Documentation Searched ⁴		
Classification System	Classification Symbols	
U.S.	73/112, Digest 11; 324/175;	
	346/20, 26, 33D	
Documentation Searched other than Minimum Documentation to the Extent that such Documents are Included in the Fields Searched ⁵		
III. DOCUMENTS CONSIDERED TO BE RELEVANT ¹⁴		
Category [*]	Citation of Document, ¹⁶ with indication, where appropriate, of the relevant passages ¹⁷	Relevant to Claim No. ¹⁵
Y	US, A, 1,339,381 (Avram) 11 May 1920, See page 1, lines 8 to 28.	1-3
Y	US, A, 3,846,701 (Sampey) 05 November 1974, See column 2, lines 20 to 31.	2
<p>[*] Special categories of cited documents: ¹⁵</p> <p>"A" document defining the general state of the art which is not considered to be of particular relevance</p> <p>"E" earlier document but published on or after the international filing date</p> <p>"L" document which may throw doubts on priority claim(s) or which is cited to establish the publication date of another citation or other special reason (as specified)</p> <p>"O" document referring to an oral disclosure, use, exhibition or other means</p> <p>"P" document published prior to the international filing date but later than the priority date claimed</p> <p>"T" later document published after the international filing date or priority date and not in conflict with the application but cited to understand the principle or theory underlying the invention</p> <p>"X" document of particular relevance; the claimed invention cannot be considered novel or cannot be considered to involve an inventive step</p> <p>"Y" document of particular relevance; the claimed invention cannot be considered to involve an inventive step when the document is combined with one or more other such documents, such combination being obvious to a person skilled in the art.</p> <p>"&" document member of the same patent family</p>		
IV. CERTIFICATION		
Date of the Actual Completion of the International Search ²		Date of Mailing of this International Search Report ²
27 AUGUST 1987		28 SEP 1987
International Searching Authority ¹		Signature of Authorized Officer ²⁰
ISA/US		Jerry Myracle 