

(12) STANDARD PATENT
(19) AUSTRALIAN PATENT OFFICE

(11) Application No. **AU 2021246429 B2**

(54) Title
Modular cooking appliance having a grease shield

(51) International Patent Classification(s)
A47J 37/01 (2006.01) **F24C 15/14** (2006.01)
A21B 1/00 (2006.01) **F24C 15/36** (2006.01)
A21B 7/00 (2006.01)

(21) Application No: **2021246429** (22) Date of Filing: **2021.03.29**

(87) WIPO No: **WO21/202362**

(30) Priority Data

(31) Number	(32) Date	(33) Country
16/997,375	2020.08.19	US
16/838,540	2020.04.02	US

(43) Publication Date: **2021.10.07**

(44) Accepted Journal Date: **2024.08.15**

(71) Applicant(s)
Automation Tech, LLC

(72) Inventor(s)
MCKEE, Philip R.;VANLANEN, Lee

(74) Agent / Attorney
FPA Patent Attorneys Pty Ltd, Level 19, South Tower 80 Collins Street, Melbourne, VIC, 3000, AU

(56) Related Art
WO 2019/050615 A1
US 2020/0037816 A1
US 2015/0017305 A1
US 2010/0071565 A1



(51) International Patent Classification:

A47J 37/01 (2006.01) F24C 15/14 (2006.01)
A21B 1/00 (2006.01) F24C 15/36 (2006.01)
A21B 7/00 (2006.01)

(21) International Application Number:

PCT/US2021/024630

(22) International Filing Date:

29 March 2021 (29.03.2021)

(25) Filing Language:

English

(26) Publication Language:

English

(30) Priority Data:

16/838,540 02 April 2020 (02.04.2020) US
16/997,375 19 August 2020 (19.08.2020) US

(71) Applicant: **AUTOMATION TECH, LLC** [US/US]; 1400
Toastmaster Drive, Elgin, IL 60120 (US).

(72) Inventors: **MCKEE, Philip, R.**; 11887 Doolin Court, Dal-
las, TX 75230 (US). **VANLANEN, Lee**; 1820 Creekview
Circle, Mckinney, TX 75069 (US).

(74) Agent: **METELSKI, Marion, P.** et al.; Amster, Rothstein
& Ebenstein LLP, 90 Park Avenue, New York, NY 10016
(US).

(81) Designated States (unless otherwise indicated, for every
kind of national protection available): AE, AG, AL, AM,
AO, AT, AU, AZ, BA, BB, BG, BH, BN, BR, BW, BY, BZ,
CA, CH, CL, CN, CO, CR, CU, CZ, DE, DJ, DK, DM, DO,
DZ, EC, EE, EG, ES, FI, GB, GD, GE, GH, GM, GT, HN,
HR, HU, ID, IL, IN, IR, IS, IT, JO, JP, KE, KG, KH, KN,
KP, KR, KW, KZ, LA, LC, LK, LR, LS, LU, LY, MA, MD,
ME, MG, MK, MN, MW, MX, MY, MZ, NA, NG, NI, NO,
NZ, OM, PA, PE, PG, PH, PL, PT, QA, RO, RS, RU, RW,
SA, SC, SD, SE, SG, SK, SL, ST, SV, SY, TH, TJ, TM, TN,
TR, TT, TZ, UA, UG, US, UZ, VC, VN, WS, ZA, ZM, ZW.

(84) Designated States (unless otherwise indicated, for every
kind of regional protection available): ARIPO (BW, GH,

(54) Title: MODULAR COOKING APPLIANCE HAVING A GREASE SHIELD

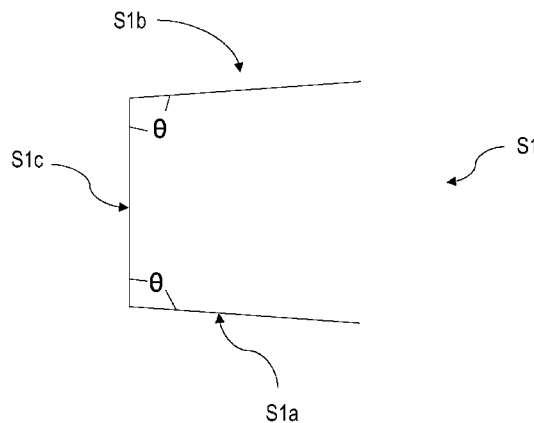

Figure 1D

(57) Abstract: A modular cooking apparatus is disclosed. The modular cooking apparatus includes a housing for containing a first and second interchangeable cooking modules. The first interchangeable cooking module contains a first oven, and the second interchangeable cooking module contains a second oven. A grease shield is located within the first oven. The second oven is different from the first oven. The modular cooking apparatus also includes a control panel for receiving cooking inputs, a controller for controlling the first and second interchangeable cooking modules, and a single power plug for receiving electrical power from a wall outlet.



WO 2021/202362 A1

GM, KE, LR, LS, MW, MZ, NA, RW, SD, SL, ST, SZ, TZ,
UG, ZM, ZW), Eurasian (AM, AZ, BY, KG, KZ, RU, TJ,
TM), European (AL, AT, BE, BG, CH, CY, CZ, DE, DK,
EE, ES, FI, FR, GB, GR, HR, HU, IE, IS, IT, LT, LU, LV,
MC, MK, MT, NL, NO, PL, PT, RO, RS, SE, SI, SK, SM,
TR), OAPI (BF, BJ, CF, CG, CI, CM, GA, GN, GQ, GW,
KM, ML, MR, NE, SN, TD, TG).

Published:

— *with international search report (Art. 21(3))*

MODULAR COOKING APPLIANCE HAVING A GREASE SHIELD

CROSS-REFERENCE TO RELATED APPLICATIONS

5 This application claims the benefit of, and priority to, U.S. Patent Application No. 16/838,540, filed on April 2, 2020, and U.S. Patent Application No. 16/997,375, filed on August 19, 2020, which is a continuation-in-part of U.S. Patent Application No. 16/838,540, the contents of both of which are incorporated herein by reference in their entirety.

10 TECHNICAL FIELD

The present invention relates to cooking appliances in general, and in particular to a modular cooking appliance having multiple ovens capable of cooking various food types concurrently.

15 BACKGROUND

In order to cook and serve a wide variety of food items, such as pizzas, bakery products, breakfast sandwiches, proteins, etc., food-service operators generally have to possess different kinds of ovens at the same store location. Different operating skills are typically required to utilize each of the different kinds of ovens for cooking, and multiple
20 ovens tend to occupy valuable countertop spaces and require multiple electrical power plugs.

The present disclosure provides an improved cooking appliance that can streamline the cooking task of a food-service operator.

Reference to any prior art in the specification is not an acknowledgement or
25 suggestion that this prior art forms part of the common general knowledge in any jurisdiction or that this prior art could reasonably be expected to be combined with any other piece of prior art by a skilled person in the art.

By way of clarification and for avoidance of doubt, as used herein and except where the context requires otherwise, the term "comprise" and variations of the term, such as

"comprising", "comprises" and "comprised", are not intended to exclude further additions, components, integers or steps.

SUMMARY OF THE INVENTION

5 According to an aspect of the invention, there is provided a modular cooking apparatus, comprising: a housing having a first interchangeable cooking module and a second interchangeable cooking module; a first oven contained within said first interchangeable cooking module, said first oven having a first cooking chamber; a first grease shield located within said first cooking chamber, wherein said first grease shield is
10 configured to prevent grease from a food item from hitting a wall of said first cooking chamber; a second oven contained within said second interchangeable cooking module, wherein said second oven is different from said first oven; a control panel on said housing for receiving cooking inputs; a controller within said housing for controlling said first interchangeable cooking module and said second interchangeable cooking module; and a
15 single power plug for receiving electrical power from a wall outlet.

In accordance with one embodiment of the present invention, a modular cooking apparatus includes a housing for containing a first and second interchangeable cooking modules. The first interchangeable cooking module contains a first oven, and the second interchangeable cooking module contains a second oven. A grease shield is located within
20 the first oven. The second oven is different from the first oven. The modular cooking apparatus also includes a control panel for receiving cooking inputs, a controller for controlling the first and second interchangeable cooking modules, and a single power plug for receiving electrical power from a wall outlet.

All features and advantages of the present invention will become apparent in the
25 following detailed written description.

BRIEF DESCRIPTION OF THE DRAWINGS

The invention itself, as well as a preferred mode of use, further objects, and advantages thereof, will best be understood by reference to the following detailed

description of an illustrative embodiment when read in conjunction with the accompanying drawings, wherein:

Figure **1** is an isometric view of a modular cooking appliance, in accordance with one embodiment;

5 Figure **1A** is an isometric view of the structure of a modular cooking appliance, according to an alternative embodiment;

Figure **1B** is an isometric view of an interchangeable cooking module within the modular cooking appliance from Figure **1A**, according to one embodiment;

10 Figure **1C** is an isometric view of a back wall within the interchangeable cooking module from Figure **1B**, according to one embodiment;

Figure **1D** is a top view of a grease shield to be placed within the interchangeable cooking module from Figure **1B** in accordance with one embodiment;

Figures **2A-2C** are cross-sectional views of an impingement oven within the modular cooking appliance from Figure **1**, according to one embodiment;

15 Figure **3** is a diagram of the heating and airflow system within the impingement oven from Figures **2A-2C**, according to one embodiment;

Figure **4** is an isometric view of a convection oven within the modular cooking appliance from Figure **1**, according to one embodiment;

20 Figure **5** is a diagram of a heating and airflow system within the convection oven from Figure **4**, according to one embodiment; and

Figure **6A** is a front cross-sectional view of a microwave oven within the modular cooking appliance from Figure **1**, according to one embodiment;

Figure **6B** is an enlarged isometric view of a cook rack within the microwave oven from Figure **6A**;

5 Figures **6C-6E** are cross-sectional views of a food transport system within the microwave oven from Figure **6A**, according to one embodiment;

Figure **7** is a block diagram of a controller for controlling various oven modules within the modular cooking appliance from Figure **1**, according to one embodiment;

10 Figure **8A** shows an example of a Food Entry Table within the modular cooking appliance from Figure **1**;

Figure **8B** shows an example of a Maximum Current Drawn Table within the modular cooking appliance from Figure **1**;

Figure **8C** shows an example of a Current Drawn History Table within the modular cooking appliance from Figure **1**; and

15 Figure **9** is a flow diagram of a method for cooking food items via the modular cooking appliance from Figure **1**, according to one embodiment.

DETAILED DESCRIPTION OF A PREFERRED EMBODIMENT

I. Configuration of modular cooking appliance

20 Referring now to the drawings and in particular to Figure **1**, there is depicted an isometric view of a modular cooking appliance, in accordance with one embodiment. As shown, a modular cooking appliance **10** is defined by a housing **11** containing multiple interchangeable cooking modules. For the present embodiment, housing **11** includes interchangeable cooking modules **12a-12c**, but it is understood by those skilled in the art
25 that the number of interchangeable cooking modules within housing **11** can be more or less than three. Each of interchangeable cooking modules **12a-12c** is for receiving an oven. The ovens contained within interchangeable cooking modules **12a-12c** may be identical or different from each other. For the present embodiment, interchangeable cooking module
30 **12a** contains an impingement oven that may be used to cook pizzas, interchangeable cooking module **12b** contains a convection oven that may be used to cook more delicate

yeast-rising food items such as cinnamon rolls, and interchangeable cooking module **12c** contains a microwave oven that may be used to cook hot dogs.

Alternatively, interchangeable cooking module **12a** may contain a first convection oven, interchangeable cooking module **12b** may contain a second convection oven, and
5 interchangeable cooking module **12c** may contain an impingement oven. Basically, modular cooking appliance **10** may contain any combination of ovens based on the preferences of food-service operators. Any one of interchangeable cooking modules **12a-12c** contained within modular cooking appliance **10** can be swapped out by field service personnel without disturbing other aspects of modular cooking appliance **10**.

10 For the present embodiment, the heights of interchangeable cooking modules **12a-12c** are identical such that the height of housing **11** corresponds to a total number of interchangeable cooking modules installed. Alternatively, the heights of interchangeable cooking modules **12a-12c** may vary from each other, depending on the type of oven contained within. For example, a convection oven that cooks yeast-raised products may
15 be taller than an impingement oven that cooks pizzas. Accordingly, the height of housing **11** will correspond to the total height of the ovens contained within.

Interchangeable cooking modules **12a-12c** include openings **16a-16c**, respectively, to allow food items to be transported into ovens located within interchangeable cooking modules **12a-12c**.

20 Modular cooking appliance **10** includes a common control panel **17** for controlling all the various ovens and food loading mechanisms contained within interchangeable cooking module **12a-12c**. Each of the food loading mechanisms allows food items to be loaded within a cooking chamber of a respective oven. After food items have been placed on a food loading mechanism, an operator can enter operating parameters, such as cooking
25 temperature, cooking time, blower speed, etc., via control panel **17** to effectuate cooking controls on the food items to be cooked, and the food loading mechanism will automatically transport the food items into the oven to begin cooking.

Alternatively, food items can be manually placed within a cooking chamber of an oven by an operator, without using a food loading mechanism or when there is no food
30 loading mechanism attached to an oven.

Control panel **17** is preferably implemented with a touch-screen but it can also be implemented with keypads and liquid crystal display (LCD) that are well-known in the art.

Referring now to Figure **1A**, there is depicted an isometric view of the structure of modular cooking appliance **10**, in accordance with an alternative embodiment. As shown, a modular cooking appliance **10'** is defined by a housing **11'** containing interchangeable cooking modules **12a-12c**. Each of interchangeable cooking modules **12a-12c** is for receiving an oven, such as a microwave oven, a convection oven, an impingement oven or the like.

Each of interchangeable cooking modules **12a-12c** is associated with one of front-facing slots **14a-14c**, respectively. Openings **16a-16c** allow food items to be transported between ovens located within interchangeable cooking modules **12a-12c** and their associated front-facing slots **14a-14c**. For example, each of front-facing slots **14a-14c** may contain a food loading mechanism for transporting food placed thereon to ovens contained within adjacent interchangeable cooking modules **12a-12c** via corresponding openings **16a-16c**, respectively. Specifically, food placed on a food loading mechanism contained in front-facing slot **14a** will be transported into an oven contained in interchangeable cooking module **12a**, food placed on a food loading mechanism contained in front-facing slot **14b** will be transported into an oven contained in interchangeable cooking module **12b**, and food placed on a food loading mechanism contained in front-facing slot **14c** will be transported into an oven contained in interchangeable cooking module **12c**. After food has been cooked, the food can be returned by the food loading mechanism back to the front-facing slot from which it entered the associated oven.

Modular cooking appliance **10'** includes a common control panel **17'** for controlling all the various ovens and food loading mechanisms contained within interchangeable cooking module **12a-12c** and front-facing slot **14a-14c**, respectively.

- 6 -

A. Interchangeable cooking module

The basic construction of interchangeable cooking modules **12a-12c** are substantially identical to each other. Thus, the basic construction of only interchangeable cooking module **12a** will be further described in details.

5 With reference now to Figure **1B**, there is illustrated an isometric view of interchangeable cooking module **12a**, in accordance with one embodiment. As shown, interchangeable cooking module **12a** includes a space for containing an oven (not shown) and two openings, such as openings **16a** and **16a'**, on both ends of the space for containing an oven. Along the longitudinal axis, the upper half of interchangeable cooking module
10 **12a** is substantially identical to the lower half of interchangeable cooking module **12a** such that either opening **16a** or opening **16a'** can be used for passage of food items, depending on the orientation of interchangeable cooking module **12a** within housing **11**. During assembly, one of openings **16a** and **16a'** can be closed up with a back wall (see Figure **1C**), after the orientation of interchangeable cooking module **12a** within housing **11** has been
15 decided.

The top and bottom of interchangeable cooking module **12a** are formed by insulating surfaces **18**. Insulating surfaces **18** include a filling envelope that can be filled with a substance of high specific-heat. For example, after an oven has been placed within interchangeable cooking module **12a**, a liquid containing a high specific-heat substance in
20 suspension, such as sand or salt suspended in silicone, can be injected into the filling envelope within insulating surfaces **18** until insulating surfaces **18** are fully expanded into the space between insulating surfaces **18** and the oven. Heat energy is stored in the high specific-heat substance when the oven is being heated.

Referring now to Figure **1C**, there is illustrated an isometric view of a back wall
25 within interchangeable cooking module **12a** from Figure **1B**, in accordance with one embodiment. As shown, a back wall includes a set of connectors **15-1** to **15-6**. During assembly, an oven module to be placed within interchangeable cooking module **12a** is fully seeded therein in order to achieve a connection between a subset of connectors **15-1** to **15-6** and the oven module. Each oven type includes a specific set of electrical connectors to
30 be mated with the corresponding ones of connectors **15-1** to **15-6** in order to activate the

- 7 -

proper electrical and control network for the operations of the oven. For example, an impingement oven includes electrical connectors for mating with connectors **15-1** and **15-4**, a convection oven includes electrical connectors for mating with connectors **15-2** and **15-5**, and a microwave oven includes electrical connectors for mating with connectors **15-3** and **15-6**.

Referring now to Figure **1D**, there is illustrated a top view of a grease shield, in accordance with one embodiment. As shown, a grease shield **S1** includes a left wall **S1a**, a right wall **S1b** and a back wall **S1c**, all connecting to each other to form an U-shape shield. At least one of left, right and back walls **S1a-S1c** includes multiple small openings for return air to pass. Left wall **S1a** and back wall **S1c** of grease shield **S1** are joined at an angle θ between 90° and 105° . Similarly, right wall **S1b** and back wall **S1c** of grease shield **S1** are joined at an angle θ between 90° and 105° .

Grease shield **S1** can be placed inside an oven within an interchangeable cooking module, such as interchangeable cooking module **12a** from Figure **1B**. The purpose of grease shield **S1** is to prevent grease from food from hitting the walls of oven chamber during cooking. Thus, grease shield **S1** should be placed inside an oven chamber located within an interchangeable cooking module before cooking begins. Grease shield **S1** can be removed from the oven chamber at any time for cleaning.

B. Impingement oven

With reference now to Figures **2A-2C**, there are depicted cross-sectional views of an impingement oven within interchangeable cooking module **12a** of modular cooking appliance **10** from Figure **1**, in accordance with one embodiment. As shown, an impingement oven **20** includes a housing **21** for accommodating a cavity **29** and a cavity opening **28**. Impingement oven **20** also includes a substantially planar food loading platform **23**. Food loading platform **23** is configured to receive a cooking plate **25**. Any food item intended to be cooked by impingement oven **20** is initially placed on either cooking plate **25** or food loading platform **23**. When food items are being cooked, food

loading platform **23** and cooking plate **25** are located inside cooking cavity **29**, as shown in Figure **2C**.

In addition, housing **21** also contains a top plenum **35** and a bottom plenum **38**. Top plenum **35** is connected to top air inlet plate **34**. Bottom plenum **38** is connected to a bottom air inlet plate **37**. Top air inlet plate **34**, top plenum **35**, bottom air inlet plate **37** and bottom plenum **38** are part of the heating and airflow system for impingement oven **20** such that heated air in top plenum **35** and bottom plenum **38** are in gaseous communication with cavity **29** through top air inlet plate **34** and bottom air inlet plate **37**, respectively. Top air inlet plate **34** and bottom air inlet plate **37** include multiple openings for directing hot pressured airstream towards any food items placed on food loading platform **23** located within cavity **29**. It is understood by those skilled in the art that top plenum **35** or bottom plenum **38** could be in gaseous communication with cavity **29** via a variety of air opening configurations such as circular openings, nozzles, tubes, rectangular openings and the like. Moreover, air can enter cavity **29** through only one of top plenum **35** or bottom plenum **38**.

Impingement oven **20** is also associated with a food transport system **22**. As shown, food transport system **22** includes food loading platform **23** connected to a food transport carriage **c1** via a connector **27**. Food loading platform **23** can be transported in and out of cooking cavity **29** by a belt drive mechanism that includes a belt **b1**, a belt drive wheel **w1** that is driven by a belt drive motor **m1** and an opposing belt wheel **w2**. Belt **b1** is connected to carriage **c1** via belt locks **BL1** and **BL2**. Carriage **c1** is connected to carriage skids **s1**. For the present embodiment, there are four carriage skids connected to carriage **c1**, with two front carriage skids **s1**, as shown in Figure **2A**, and two back carriage skids (not shown) on the opposing side of carriage **c1**. Belt **b1** moves between front carriage skids **s1** and back carriage skids. When belt drive motor **m1** is engaged, belt **b1** moves carriage **c1**, thereby transporting food loading platform **23** in and out of cooking cavity **29** through opening **28**, as shown in Figure **2B**.

During the cooking process, food loading platform **23** may be moved to and fro, about 1", for promoting food cooking evenness. In order to move food loading platform **23** to and fro without air escaping through opening **28** during the cooking process, door **d1**

must be sufficiently thick to substantially block air from escaping through opening **28** at either extreme of the to and fro motion.

Operating parameters for impingement oven **20** to cook any food items placed on cooking plate **25** to be carried into cooking cavity **29** can be entered via control panel **17** (from Figure 1).

With reference now to Figure **3**, there is depicted a diagram of the heating and airflow system within impingement oven **20**, in accordance with one embodiment. Air within cooking cavity **29** is initially pumped in to a heater plenum **31** via an intake opening **30**. Heater plenum **31** includes a base heater **39a** and a boost heater **39b**. After air has been sufficiently heated by base heater **39a** and boost heater **39b**, the heated air is then directed to top plenum **35** via a top blower **32** and to a bottom plenum **38** via a bottom blower **33**. During cooking, base heater **39a** is usually turned on, and boost heater **39b** is only activated when necessary. The pressurized hot air formed within top plenum **35** is subsequently directed to cavity **29** via multiple openings located on top air inlet plate **34** (from Figures **2A-2C**). Similarly, pressurized hot air formed within bottom plenum **38** is subsequently directed to cavity **29** via multiple nozzles located on bottom air inlet plate **37** (from Figures **2A-2C**). Although heated air is shown to be sent to top air plenum **35** and bottom plenum **38** via separate blowers, it is understood by those skilled in the art that heated air can be sent to both top plenum **35** and bottom plenum **38** via a single blower.

C. Convection oven

With reference now to Figure **4**, there is depicted an isometric view of a convection oven within slot **12b** of modular cooking appliance **10** from Figure **1**, in accordance with one embodiment. As shown, a convection oven **40** includes a housing having a cooking cavity **49** defined by a top air inlet plenum **41**, a bottom air inlet plenum **42**, a rear wall **43**, and two side walls **44a**, **44b**. Located on one or more of side walls **44a**, **44b** and rear wall **43** are return air openings, such as openings **45a**, for returning air to a blower system (not shown). Preferably, convection oven **40** also includes a food loading mechanism similar to food loading mechanism **22** shown in Figures **2A-2C**.

- 10 -

Referring now to Figure 5, there is depicted a cross-sectional view of a heating and airflow system within convection oven 40, in accordance with one embodiment. As shown, a blower 51 is preferably located at the rear of convection oven 40. Heated air from a heater (not shown) is directed by blower 51 over triangular air diverter 52 that separates the air exiting blower 51 into top and bottom airstreams flowing through top and bottom air inlet plenums 41 and 42 and into cooking cavity 49 through top and bottom convection plates 45 and 46. After transferring heat from the heated air to food placed in cooking cavity 49, the air is drawn through return a return air path.

An operator can enter commands, such as cooking temperature, cooking time, fan speed, etc., via control panel 17 (from Figure 1) to effectuate cooking controls on any food items placed within cooking cavity 49 of convection oven 40.

D. Hot Air oven with a built-in magnetron

With reference now to Figure 6A, there is illustrated a cross-sectional view of a hot air oven having a built-in magnetron within interchangeable cooking module 12c of modular cooking appliance 10 from Figure 1, according to one embodiment. As shown, a hot air oven 60 includes a cooking chamber 69 and at least one magnetron 81 configured to generate microwave radiation for cooking chamber 69. Hot air oven 60 may also include a second magnetron (not shown) that may be activated concurrently with, or independently from magnetron 81. In some embodiments, hot air oven 60 further includes a waveguide 82 configured to direct and/or distribute the microwave radiation generated by magnetron 81 into cooking chamber 69.

In addition, hot air oven 60 includes a blower 83 for providing air flow to facilitate hot air cooking within cooking chamber 69. In a preferred embodiment, multiple air guides 84a direct heated air in a horizontal direction, as depicted by an arrow a1, through a horizontal plenum 84b where a portion of the air is directed through openings 84c in a jet plate 84d, while the remainder of the air is directed through a vertical plenum 84e and through a bottom air opening 84f located at the bottom of cooking chamber 69. The air passing through bottom air opening 84f moves in the opposite horizontal direction of the air passing through horizontal plenum 84b as depicted by an arrow a2 beneath a cook rack 85

that supports food and includes multiple air deflectors **86** having different lengths. An enlarged isomeric view of cook rack **85** is shown in Figure **6B**.

Air moves in a horizontal direction below cook rack **85**. The angles between air deflectors **86** and cook rack **85** are less than 90° with respect to the oncoming horizontally moving air. The length of air deflectors **86** further from the source of the horizontally moving air is greater than the length of air deflectors **86** nearest the source of horizontally moving air. The air passing through air deflectors **86** is directed upwards as depicted by an arrow **a3**, then through return air openings **84i** back towards blower **83**.

With reference now to Figures **6C-6E**, there is illustrated cross-sectional views of a food transport and cooking evenness mechanism for microwave oven **60**, according to one embodiment. As shown, a platform **63** is connected to a food transport carriage **c1** via a connector **67**. Platform **63** can be transported in and out of cooking cavity **69** by a belt drive mechanism that includes a belt **b1**, a belt drive wheel **w1** that is driven by a belt drive motor **m1** and an opposing belt wheel **w2**. Carriage **c1** is connected to carriage skids **s1**. For the present embodiment, there are four carriage skids connected to carriage **c1**, with two front carriage skids **s1**, as shown in Figure **6B**, and two back carriage skids (not shown) on the opposing side of carriage **c1**. Belt **b1** moves between front carriage skids **s1** and back carriage skids. When belt drive motor **m1** is engaged, belt **b1** moves carriage **c1**, thereby transporting platform **63** in and out of cooking cavity **69** through opening **68**, as shown in Figure **6B**.

Food surface **64a** is connected to and supported by skids **65** which rest on platform **63**. Food may be placed directly on food surface **64a** or preferably on a dish or plate (not shown) which is then placed on food surface **64a**. Food surface **64a** is connected to crank-and-cam mechanism **62** via rod **64b** which penetrates door **66a** and door shunt **66b**.

During cooking, as shown in Figures **6D-6E**, food surface **64a** may be moved to and fro within cooking chamber **69** for promoting food cooking evenness. In order to move food surface **64a** to and fro within cooking chamber **69**, a motor **61** and a crank-and-cam mechanism **62** are utilized to move a rod **64b** connected to food surface **64a**. Motor **61** is located outside an oven door formed by an external cover **66a** and an internal cover **66b**. External cover **66a** and internal cover **66b** are specifically designed to prevent

- 12 -

microwave radiation from escaping through opening **68** during the cooking process. Two small concentric openings, which are approximately 0.3 inch in diameter, are provided in external cover **66a** and internal cover **66b** to allow rod **64b** to go through. The wavelength of microwaves is approximately 12 cm, and the diameter of each of the two small concentric openings needs to be small enough to prevent microwave radiation from escaping through the openings. During the cooking process, crank-and-cam mechanism **62** translates the rotational movement from motor **61** into a linear reciprocating movement to move food surface **64a** to and fro within cooking chamber **69**. Food surface **64a** can be moved on top of platform **63** via skids **65**.

For the present embodiment, motor **61** and crank-and-cam mechanism **62** are utilized to translate a rotational movement to a linear reciprocating movement. It is understood by those skilled in the art that other mechanisms can be utilized to translate a rotational movement to a linear reciprocating movement, or to provide a linear reciprocating movement directly.

Operating parameters for microwave oven **60** to cook any food items placed within cooking cavity **69** can be entered via control panel **17** (from Figure 1).

II. Controller

Modular cooking appliance **10** may include various oven types, but it is also able to be powered by a single-phase 50-Amp outlet as sole power source via a single power plug. Thus, modular cooking appliance **10** can be employed by any food service establishments without additional modification to the commonly found single-phase 50-Amp outlets.

Referring now to Figure 7, there is depicted a block diagram of a controller for controlling various oven modules within modular cooking appliance **10**, according to one embodiment. As shown, a controller **70** includes a processor **71**, a multiplexor **72**, a memory **73** and control modules **74a-74c**. Memory **73** includes random-access memories and read-only memories that are non-erasable as well as electronically programmable. Software and data related to the operations of modular cooking appliance **10** are stored within memory **73**. Control module **74a** is associated with interchangeable cooking module **12a** (from Figure 1A), control module **74b** is associated with interchangeable

cooking module **12b**, and control module **74c** is associated with interchangeable cooking module **12c**. During operation, control modules **74a-74c** monitor the real-time current consumption of interchangeable cooking modules **12a-12c**, respectively, and distribute current from a power supply **75** to interchangeable cooking modules **12a-12c** and the associated ovens, as needed.

All ovens within modular cooking appliance **10** that cook with hot air, such as impingement oven **20** and convection oven **40**, are provided with a base heater and at least one boost heater. For example, impingement oven **20** includes base heater **39a** and boost heater **39b** (*see* Figure **3**). All ovens within modular cooking appliance **10** that cook with microwaves, such as microwave oven **60**, are provided with at least one magnetron. For example, microwave oven **60** includes magnetron **61** (*see* Figure **6**). If microwave oven **60** is provided with a second magnetron, it may be activated independently from magnetron **61**.

III. Adaptive Power Management

As mentioned above, modular cooking appliance **10** is configured with impingement oven **20**, convection oven **40** and microwave oven **60**, for the present embodiment, with all the ovens operating from a single-phase 50-Amp outlet commonly found in commercial kitchens. However, those skilled in the art will appreciate that modular cooking appliance **10** may have any number and types of ovens all powered by a single power plug. For the present embodiment, the maximum current drawn by each of impingement oven **20**, convection oven **40** and microwave oven **60** are as follows:

	<u>component</u>	<u>max. current drawn</u>
impingement oven 20	base heater	8 Amps
	first boost heater	12 Amps
	second boost heater	12 Amps
convection oven 40	base heater	4 Amps
	first boost heater	12 Amps
	second boost heater	12 Amps
microwave oven 60	first magnetron	8 Amps
	second magnetron	8 Amps.

- 14 -

In addition, the baseline current drawn by all the ancillary components (such as processor 71, multiplexor 72, memory 73, etc.) within modular cooking appliance 10 during operation is 5 Amps. Thus, with a 50-Amp power source, a maximum of $(50-5=)$ 45 Amps current is available for powering ovens at any given time.

5 Needless to say, there are many benefits if more than one oven within modular cooking appliance 10 can be utilized to cook food items at the same time. However, as shown above, the maximum current drawn by impingement oven 20 is $(8+12+12=)$ 32 Amps, and the maximum current drawn by convection oven 40 is $(4+12+12=)$ 28 Amps. Thus, it is not possible to use both impingement oven 20 and convection oven 40 for
10 cooking food items at the same time because the total current drawn by the two ovens (and all the ancillary components) would exceed the 50-Amp limitation.

In order to overcome the above-mentioned 50-Amp barrier, modular cooking appliance 10 employs Adaptive Power ManagementTM (APM) technology to intelligently allocate current to each of the ovens such that multiple ovens can be utilized for cooking
15 food items concurrently during some of the time. There are two control modes under APM, namely, temperature-control mode and time-control mode.

A. Temperature-control mode

20 When cooking a food item under temperature-control mode, the oven temperature is monitored, and a temperature-control feedback loop is utilized to control the oven temperature for cooking the food item. Specifically, the base and boost heaters within an associated oven are turned on when the measured oven temperature drops below a set cook temperature, and the base and boost heaters within the associated oven are turned off when the measured oven temperature is at or above the set cook temperature.

25 During temperature-control mode, the amount of time an oven is turned on and the associated current drawn during the cook cycle are recorded and stored in a Current Drawn History Table (more details below) to be used in time-control mode described below, when necessary.

B. Time-control mode

When cooking a food item under time-control mode, the oven temperature and time for cooking the food item are guided by the information previously stored in a Current Drawn History Table (more details below). Specifically, the base and boost heaters within an associated oven are allocated the power during each time unit that was consumed by that oven for cooking the same food item when operating under temperature-control mode, as recorded in the Current Drawn History Table.

IV. Control tables

The following three control tables are utilized by modular cooking appliance **10** to perform APM during various cook cycles. The control tables can be stored in memory **73** (from Figure 7), and the information within some of the control tables will be updated throughout the course of operating modular cooking appliance **10**.

A. Food Entry Table

Before modular cooking appliance **10** can be deployed for cooking different types of food items, information regarding these food items has to be entered and stored (*i.e.*, pre-programmed) in a Food Entry Table (FET) within memory **73**. The FET contains a list of all the food items that can be cooked via the various ovens within modular cooking appliance **10** and their respective optimal cook settings. Basically, for each food item intended to be cooked via modular cooking appliance **10**, an operator needs to enter into the FET a food item name, an oven type and cook settings (such as cook time, blower speed, cook temperature, etc.) that are associated with the food item.

With reference now to Figure **8A**, there is depicted an example FET, according to one embodiment. In this FET example, four types of food items are listed, namely, pizza, sandwich, biscuits and hot dog. In addition, three separate cook stages are shown, and each cook stage contains cook settings such as start and stop times, cook temperature, blower speed and magnetron power level. Specifically, entry one and entry two include the cook settings for cooking pizza and sandwich, respectively, in an impingement oven (such as impingement oven **20**). Entry three includes the cook settings for cooking biscuits

in a convection oven (such as convection oven **40**) and entry four includes the cook settings for cooking hot dog in a microwave oven (such as microwave oven **60**).

For each of entry one through entry three, when the corresponding cook settings are deployed, the ovens will be engaged in hot air cooking, as indicated by the associated air temperatures and blower speeds. For entry four, when that cook setting is deployed, the microwave oven will be engaged in microwave cooking, as indicated by a magnetron setting greater than zero in stages 1 and 3.

B. Maximum Current Drawn Table

The Maximum Current Drawn Table contains the maximum current required for each of impingement oven **20**, convection oven **40** and microwave oven **60** to cook various food items, corresponding to the food item list stored in the FET.

With reference now to Figure **8B**, there is depicted an example Maximum Current Drawn Table. As shown, the Maximum Current Drawn Table includes an oven module column, a food name column, and multiple cook stage columns. In this example, entry one includes the maximum current drawn by impingement oven **20** for cooking pizza for a duration of 90 seconds, which corresponds to entry one of the FET from Figure **8A**. Entry two includes the maximum current drawn by impingement oven **20** for cooking sandwich for a duration of 70 seconds, which corresponds to entry two of the FET from Figure **8A**. Entry three includes the maximum current drawn by convection oven **40** for cooking biscuits for a duration of 120 seconds, which corresponds to entry three of the FET from Figure **8A**. Entry four includes the maximum current drawn by microwave **60** for cooking hot dog for a duration of 90 seconds, which corresponds to entry four of the FET from Figure **8A**.

The information stored in the Maximum Current Drawn Table will be utilized to assist in the determination of whether or not a cook process should start when two or more ovens are called for cooking food items under temperature-control mode (as will be further explained in Figure **9**).

C. Current Drawn History Table

The Current Drawn History Table contains the current drawn by each of impingement oven **20** and convection oven **40** when it is engaged for cooking each type of food items under temperature-control mode per cook cycle.

5 With reference now to Figure **8C**, there is depicted an example Current Drawn History Table. As shown, the Current Drawn History Table includes an oven module column, a food name column, and multiple time unit columns. Each of the time units (time unit 1 to time unit 8 in this example) are identical in the length of time, and each time unit can be one second, two seconds, etc., depending the time resolution required and the
10 memory available within modular cooking appliance **10**. The current drawn by each of impingement oven **20** and convection oven **40** when it is engaged for cooking a specific food item is recorded and stored in various time units accordingly throughout its entire cook cycle.

The current drawn value recorded in each time unit can be a running average of the
15 current drawn of the most recent 10 cooks of each food item. For example, the 3.2 Amps current drawn value in time unit 1 is a running average of the current drawn of the most recent 10 cooks of pizza in time unit 1 by impingement oven **20**. An operator can change the number of cooks for calculating the running average, and more than 10 cooks can be utilized to calculate the running average, depending on the accuracy needed.

20 Basically, modular cooking appliance **10** learns how much current was recently required in each time unit to cook each food item type in each of impingement oven **20** and convection oven **40** when cooking under temperature-control mode.

It is expected that the current drawn value recorded in each time unit may be drastically different even for the same oven, depending on the geographic location of the
25 oven. For example, the current drawn values for an oven located in Denver, Colorado is expected to be significantly higher than the same oven located in Dallas, Texas. Thus, before the Current Drawn History Table can be fully deployed for regular day-to-day operations, it has to be initialized and populated with some actual historic current drawn values by performing a minimum number of pre-cooks, such as 3, on location.

The information stored in the Current Drawn History Table will be utilized to assist in the determination of whether or not a cook process should be started when two or more ovens are called for cooking food items (as will be further explained in Figure 9).

In addition, for each time unit, the activation status of the associated base heater and boost heater (not shown) can also be recorded and stored in the corresponding entry of the Current Drawn History Table.

IV. Cooking process

With reference now to Figure 9, there is depicted a flow diagram of a method for cooking food items via modular cooking appliance 10, according to one embodiment. The ovens within modular cooking appliance 10 depends on the user configuration, but for the present embodiment, the ovens are impingement oven 20, convection oven 40 and microwave oven 60. After an operator has selected a food item to be cooked from a list of food items (*i.e.*, food items stored in a FET from Figure 8) shown on display 17 (from Figure 1), as shown in block 90, a determination is made whether or not any of the ovens is currently being engaged in cooking food items, as shown in block 91.

If none of the ovens is currently engaged in cooking food items, then temperature-control mode will be utilized for controlling the oven temperature of the selected oven to cook the selected food item throughout the entire cook process, as depicted in block 92. The cook cycle will be guided by the information stored within the FET.

However, if one (or more) oven is currently being engaged in cooking food items, then another determination is made whether or not the total current demand by the selected oven and the engaged oven (as well as the auxiliary components) to cook respective food items will exceed the 50-Amp limitation anytime during their entire respective cook cycle under temperature-control mode, as shown in block 93. This determination is made by looking up the Maximum Current Drawn Table to determine if the sum of the current drawn by the selected oven and the engaged oven (as well as the auxiliary components) for cooking their respective food item will exceed the 50-Amp limitation in any of the time units, for the same ovens cooking the same food types. If not, then the selected oven is allowed to cook the selected food immediately, and temperature-control mode can continually be used

to control the oven temperature of the two ovens throughout the entire cook cycle, as depicted in block **92**.

If the total current demand by the selected oven and the engaged oven (as well as the auxiliary components) to cook respective food items exceeds the 50-Amp limitation, then all the ovens will be set to use time-control mode for controlling oven temperature throughout the entire cook cycle, as depicted in block **94**. In other words, any oven that is using temperature-control mode at the time will be switched to use time-control mode to complete the cook process.

For example, if a pizza is currently being cooked in impingement oven **20**, and an operator wants to cook a biscuit in convection oven **40** at the same time, controller **70** checks the maximum current drawn by impingement oven **20** when cooking a pizza and the maximum current drawn by convection oven **40** when cooking a biscuit, by using the Maximum Current Drawn Table. In this example, the maximum current drawn by impingement oven **20** when cooking a pizza is 32 Amps, and the maximum current drawn by convection oven **40** when cooking a biscuit is 28 Amps, with a total maximum current drawn being $(32+28=)$ 60 Amps, which means the cooking control within impingement oven **20** will be switched to time-control mode.

Next, a determination is made whether or not the total current demand by the selected oven and the engaged oven (as well as the auxiliary components) to cook respective food items will exceed the 50-Amp limitation anytime in any of the time units during their entire respective cook process under time-control mode, as shown in block **95**. This determination is made by looking up the Current Drawn History Table to determine if the sum of the current drawn by the selected oven and the engaged oven (as well as the auxiliary components) does not exceed the 50-Amp limitation in each and every time unit throughout the entire cook cycle.

If the total current demand by the selected oven and the engaged oven (as well as the auxiliary components) to cook respective food items exceeds the 50-Amp limitation in any of the time units during their entire respective cook process under time-control mode, the selected oven has to wait until the total historic current drawn in each subsequent time unit is 50 Amps or less before it can start its cook process. Otherwise, if the total current

demand does not exceed the 50-Amp limitation in any of the time units, both the selected oven and the engaged oven proceed with respective cooking under time-control mode.

For example, Table I (a portion of a Current Drawn History Table) shows it takes five time units for impingement oven **20** to cook a pizza, and the current drawn during the first to fifth time units are 20, 32, 32, 32 and 8 Amps, respectively. On the other hand, it takes three time units for convection oven **40** to cook a biscuit, and the current drawn during the first to third time units are 28, 16 and 16 Amps, respectively.

	time unit 1	time unit 2	time unit 3	time unit 4	time unit 5
pizza	20	32	32	32	8
biscuit	28	16	16		

Table I

In this example, convection oven **40** can start cooking the biscuit in time unit 5 while the pizza is being cooked in impingement oven **20**. This is because the current drawn by the two ovens and auxiliary components exceeds the 50-Amp limitation if biscuits begin cooking in any of time units 1-4 but not in time unit 5.

V. Uniform operating steps for operators

The operating procedure is the same for all the ovens within modular cooking appliance **10**.

For the present embodiment, modular cooking appliance **10** enters operating mode upon completion of oven startup, during which each of impingement oven **20**, convection oven **40** and microwave oven **60** warm up to their preset operating temperatures. Once in operating mode, a listing of the various food items for which operating parameters have been entered via control panel **17** is displayed on control panel **17**. An operator can select the food item to be cooked from among the items displayed on control panel **17** and places the food on a food loading mechanism of the corresponding oven. The food is then transported into the heated oven cavities for cooking.

After the cook process has been completed, the cooked food is transported from the oven cavities back to where the food entered the associated oven. The food loading mechanisms are not themselves heated, effectively concluding the cook process once the food exits the heated oven cavities. However, because the food loading mechanisms are adjacent to the heated oven cavities contained in interchangeable cooking modules **12a-12c**, residual heat from the heated oven cavities contained in interchangeable cooking modules **12a-12c** serves to reduce the rate of heat loss experienced by the recently cooked food.

Food items may be concurrently cooked in impingement oven **20**, convection oven **40** and microwave oven **60** of modular cooking appliance **10**. Similar food items may be consecutively cooked in impingement oven **20**, convection oven **40** and microwave oven **60** of modular cooking appliance **10**. For example, pizzas may be cooked back to back to back in impingement oven **20** while cinnamon rolls are being cooked back to back to back in convection oven **40** while breakfast sandwiches are being cooked back to back to back in microwave oven **60**. In order for the amount of heat energy delivered to the similar food items cooked consecutively in the various ovens to be the same in each of the back to back to back cooks when modular cooking appliance **10** is powered by an electric circuit of no more wattage than a typical single-phase 50-Amp outlet, the volumes of the cook cavities held within interchangeable cooking modules **12a-12c** are no larger than 1.5 cubic feet for the convection oven, 1.25 cubic feet for the impingement oven and 1 cubic feet for the microwave oven.

As has been described, the present invention provides a modular cooking appliance having multiple ovens.

While the invention has been particularly shown and described with reference to a preferred embodiment, it will be understood by those skilled in the art that various changes in form and detail may be made therein without departing from the spirit and scope of the invention.

CLAIMS

1. A modular cooking apparatus, comprising:
 - a housing having a first interchangeable cooking module and a second interchangeable cooking module;
 - a first oven contained within said first interchangeable cooking module, said first oven having a first cooking chamber;
 - a first grease shield located within said first cooking chamber, wherein said first grease shield is configured to prevent grease from a food item from hitting a wall of said first cooking chamber;
 - a second oven contained within said second interchangeable cooking module, wherein said second oven is different from said first oven;
 - a control panel on said housing for receiving cooking inputs;
 - a controller within said housing for controlling said first interchangeable cooking module and said second interchangeable cooking module; and
 - a single power plug for receiving electrical power from a wall outlet.

2. The modular cooking apparatus of Claim 1, wherein said first grease shield includes a first wall, a second wall and a back wall.

3. The modular cooking apparatus of Claim 2, wherein an inner angle between said first wall and said back wall is between 90° and 105°.

4. The modular cooking apparatus of Claim 3, wherein an inner angle between said second wall and said back wall is between 90° and 105°.

5. The modular cooking apparatus of any one of Claims 2-4, wherein one of said first wall, said second wall and said back wall of said first grease shield includes multiple openings for return air to pass through.

6. The modular cooking apparatus of any one of Claims 1-5, wherein:

said second oven has a second cooking chamber;
a second grease shield is located within said second cooking chamber; and
said second grease shield is configured to prevent grease from a food item from hitting a wall of said second cooking chamber.

7. The modular cooking apparatus of Claim 6, wherein said second grease shield includes a first wall, a second wall and a back wall.

8. The modular cooking apparatus of Claim 7, wherein an inner angle between said first wall and said back wall is between 90° and 105°.

9. The modular cooking apparatus of Claim 8, wherein an inner angle between said second wall and said back wall is between 90° and 105°.

10. The modular cooking apparatus of any one of Claims 7-9, wherein one of said first wall, said second wall and said back wall of said second grease shield includes multiple openings for return air to pass through.

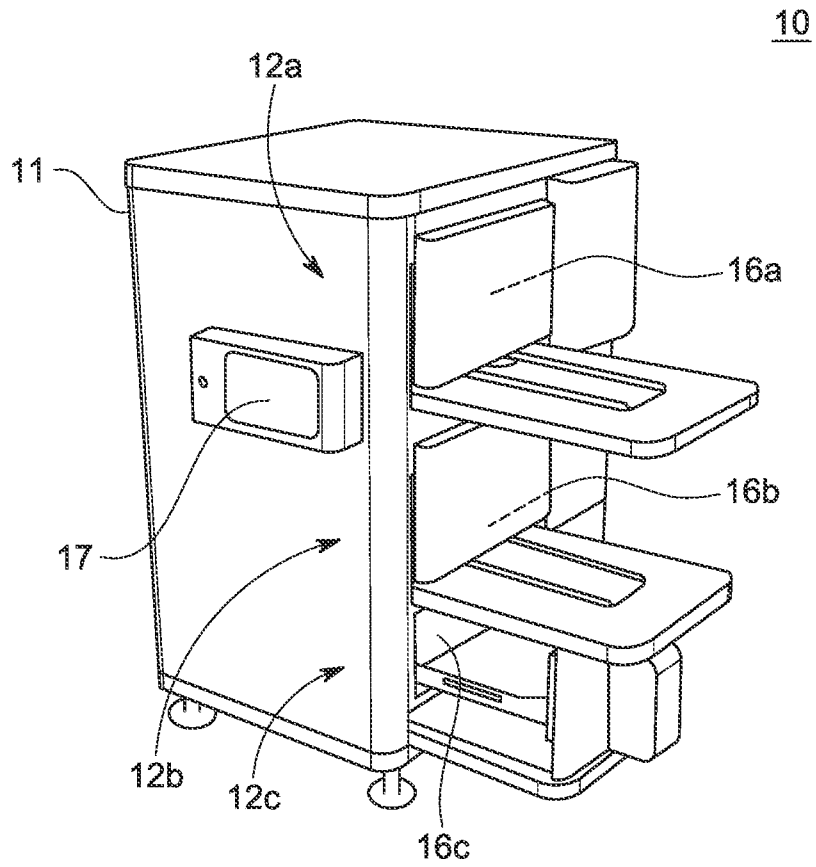

Figure 1

10'

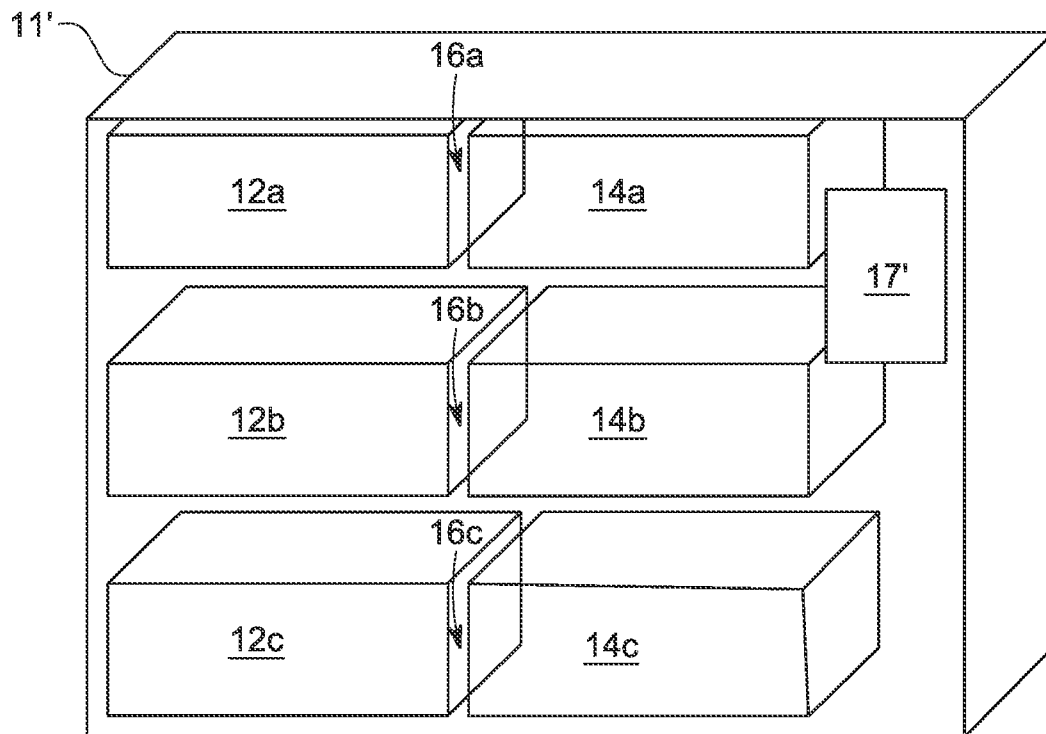

Figure 1A

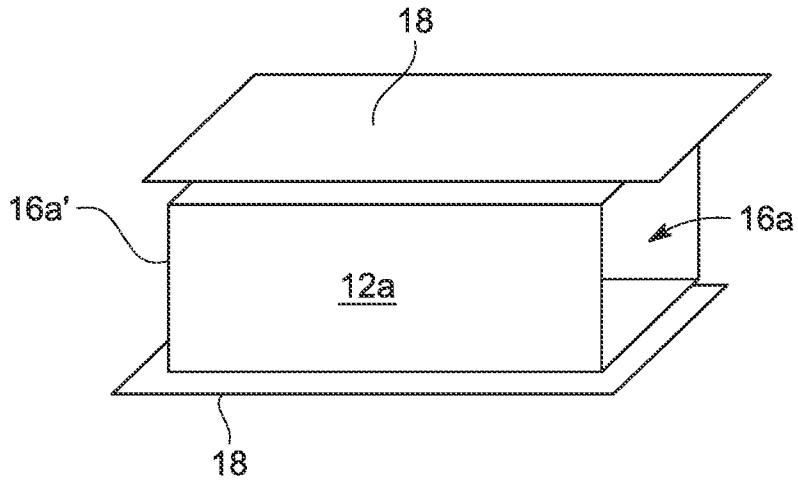

Figure 1B

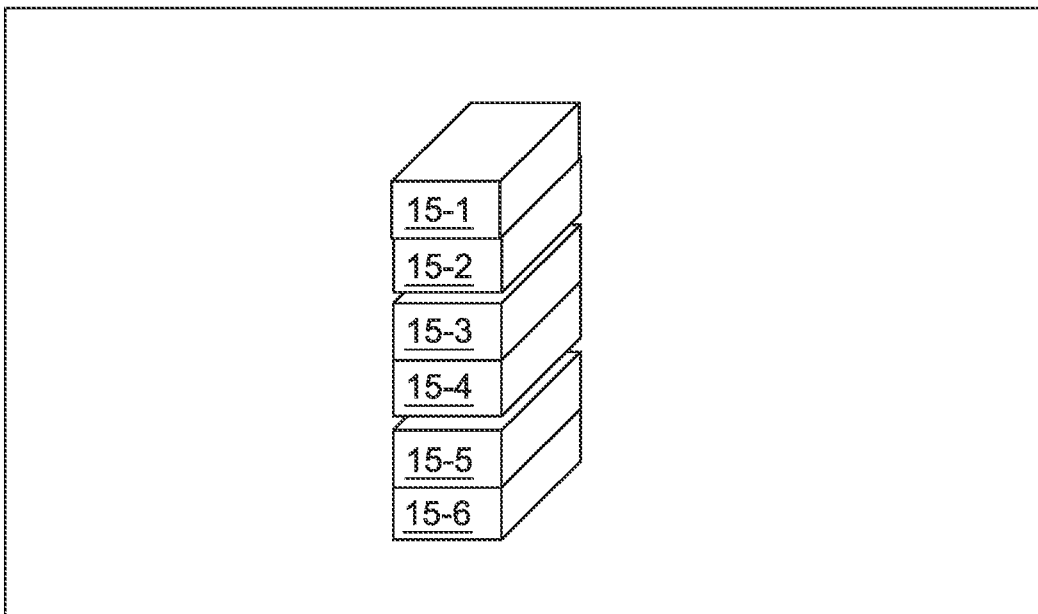

Figure 1C

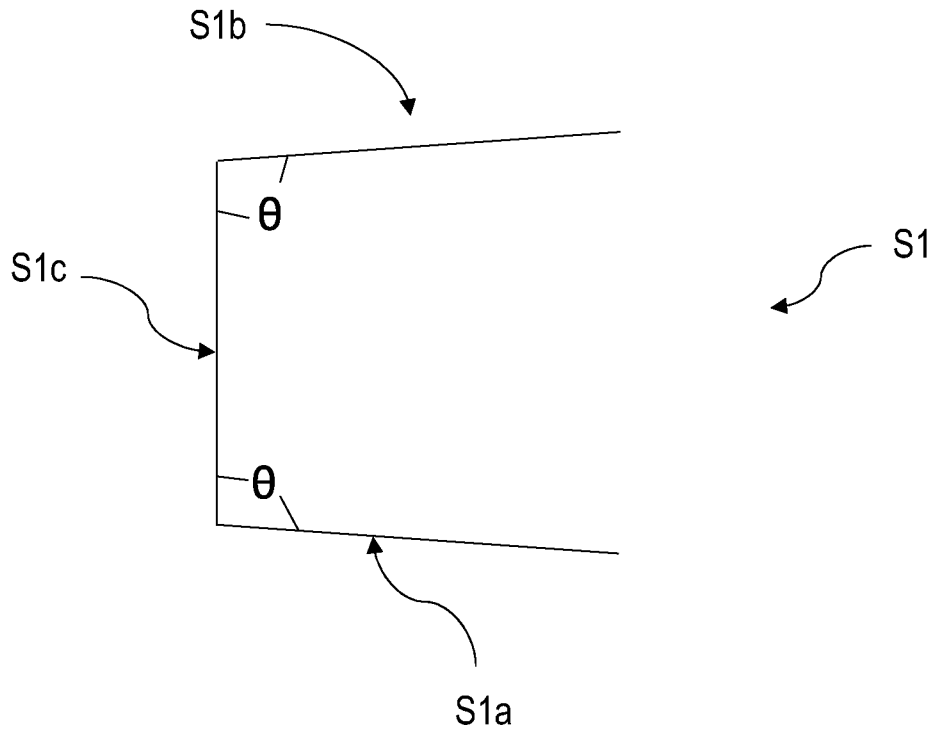

Figure 1D

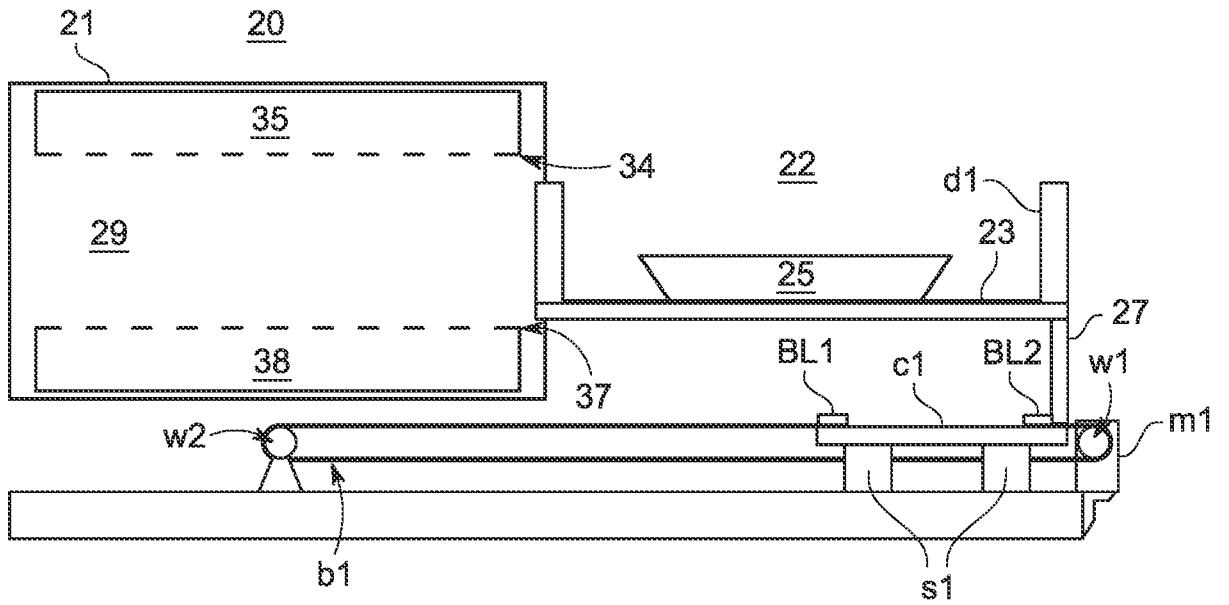

Figure 2A

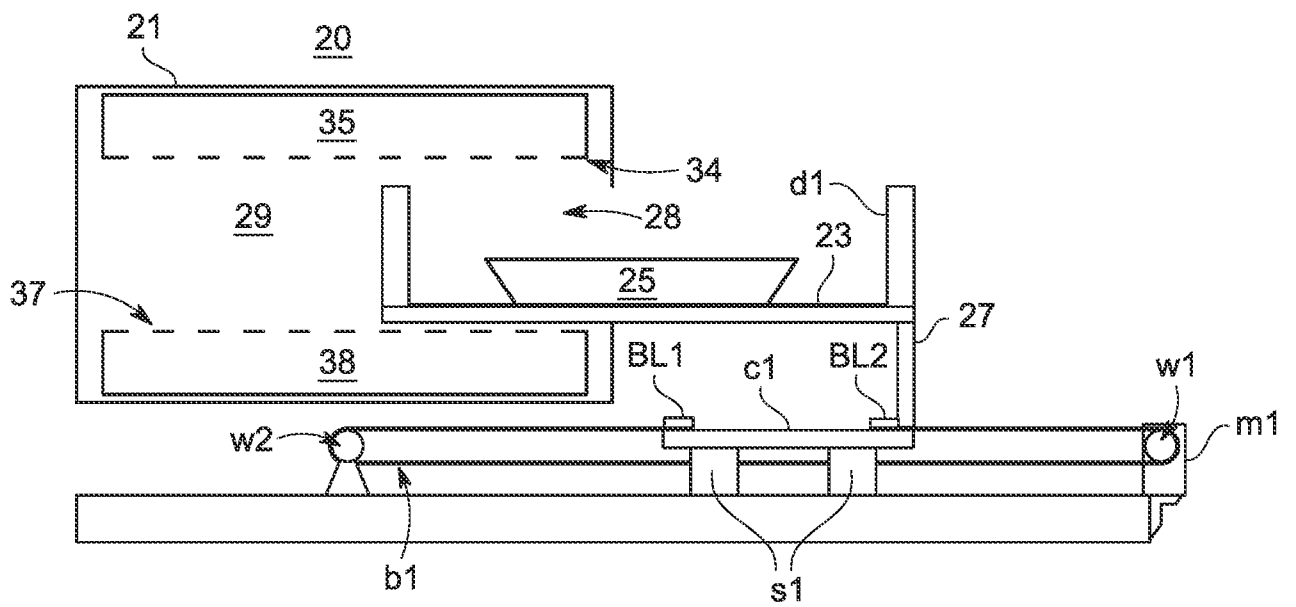

Figure 2B

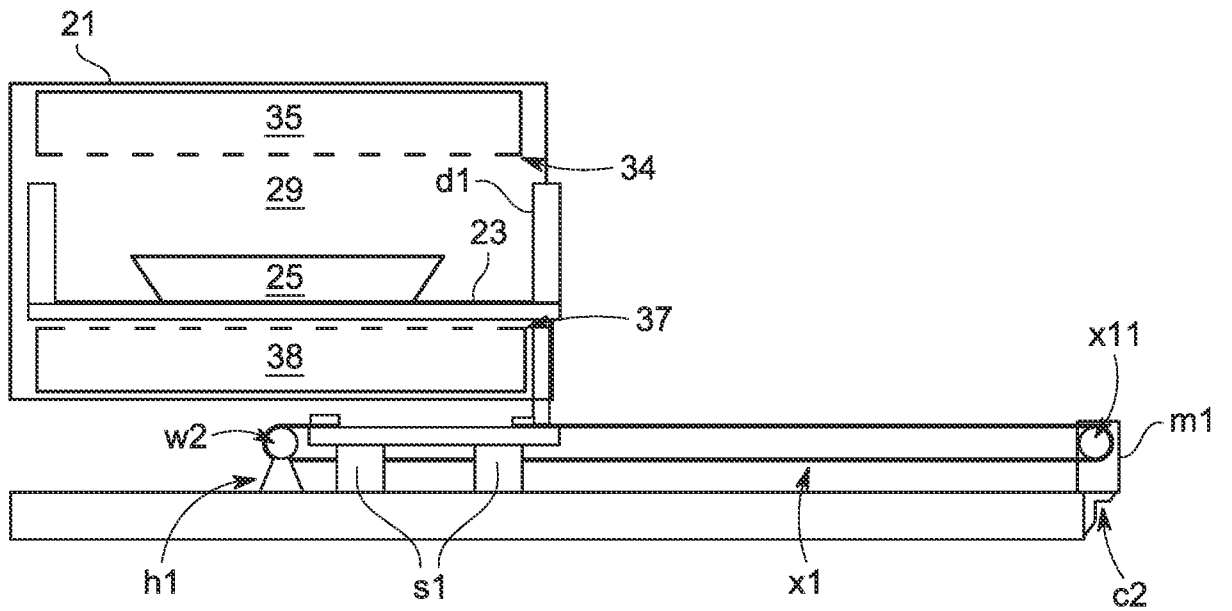

Figure 2C

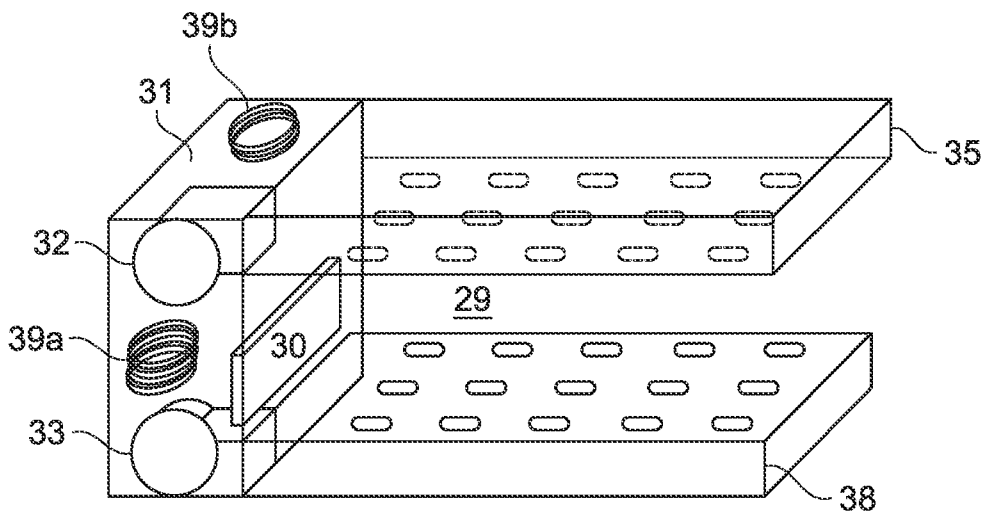

Figure 3

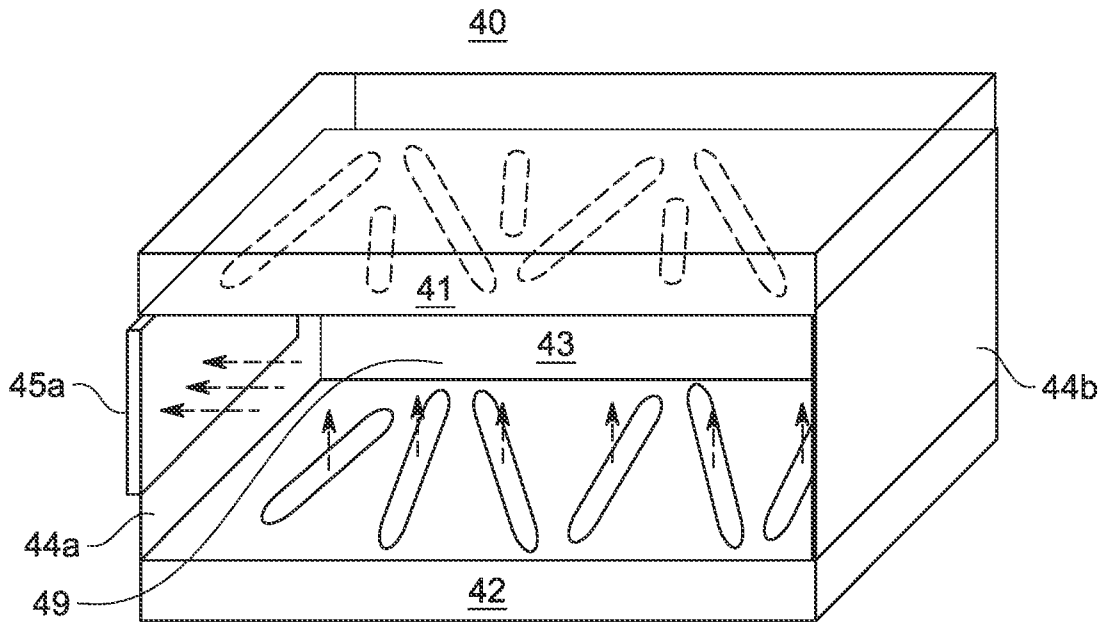

Figure 4

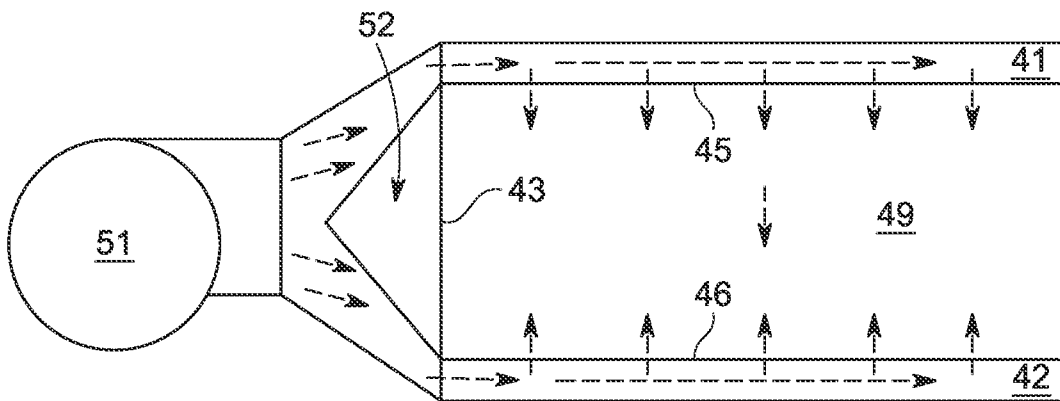

Figure 5

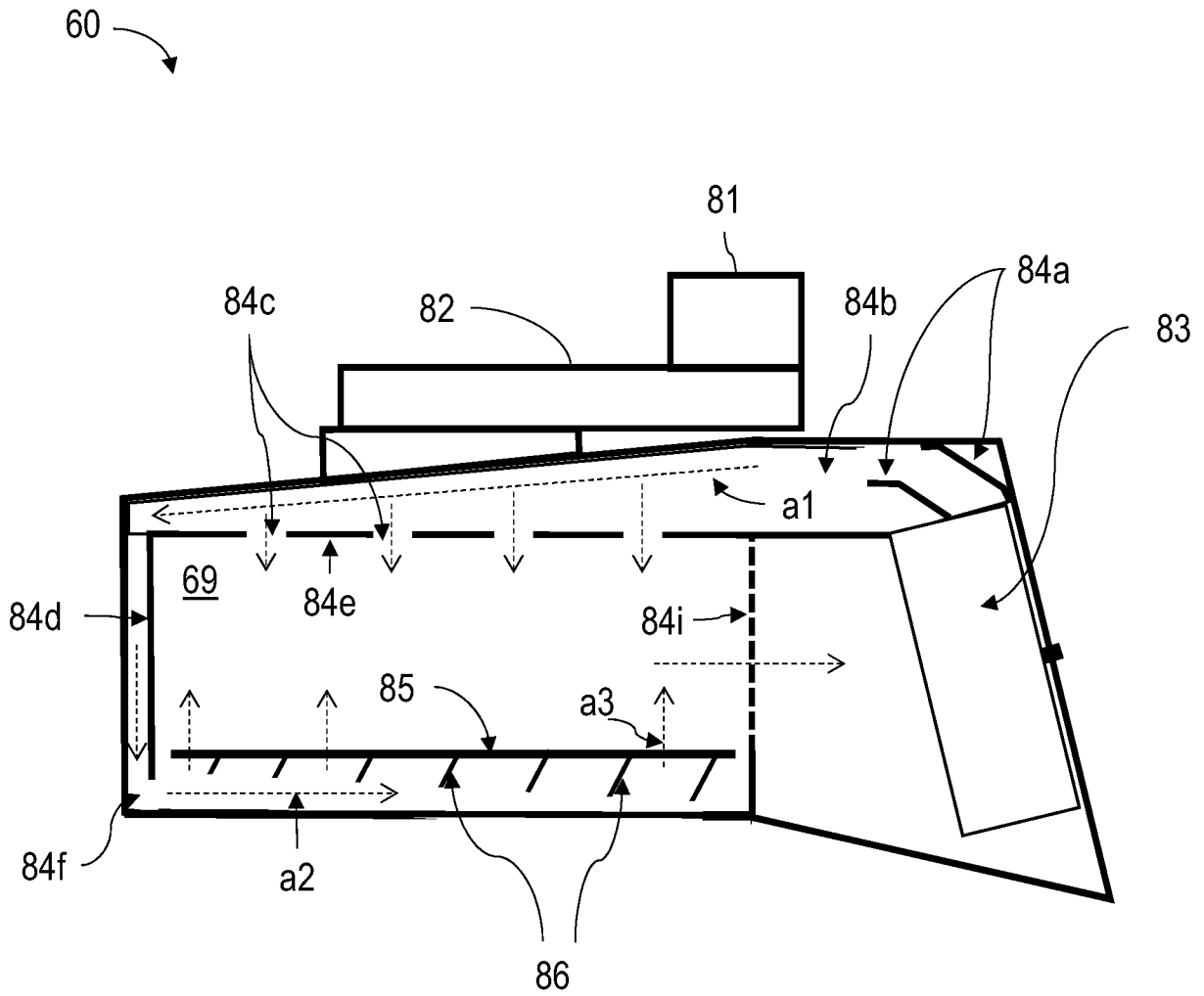

Figure 6A

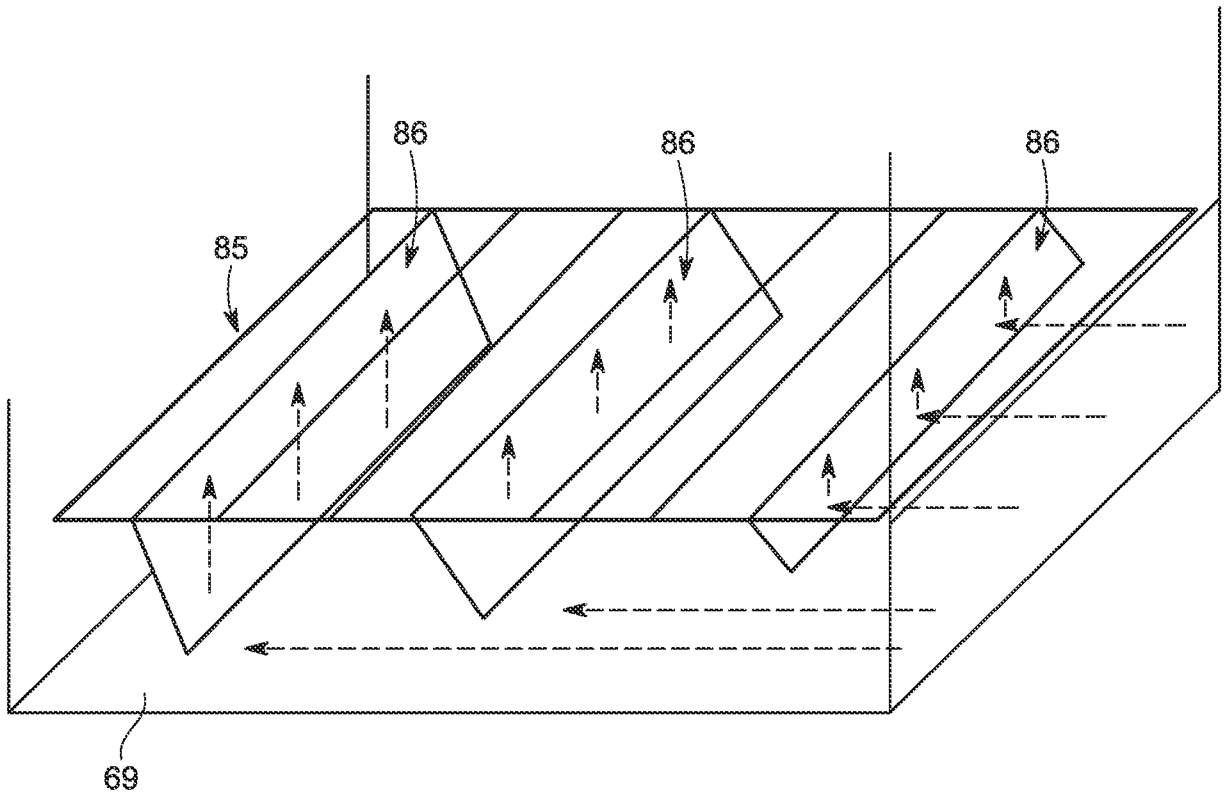

Figure 6B

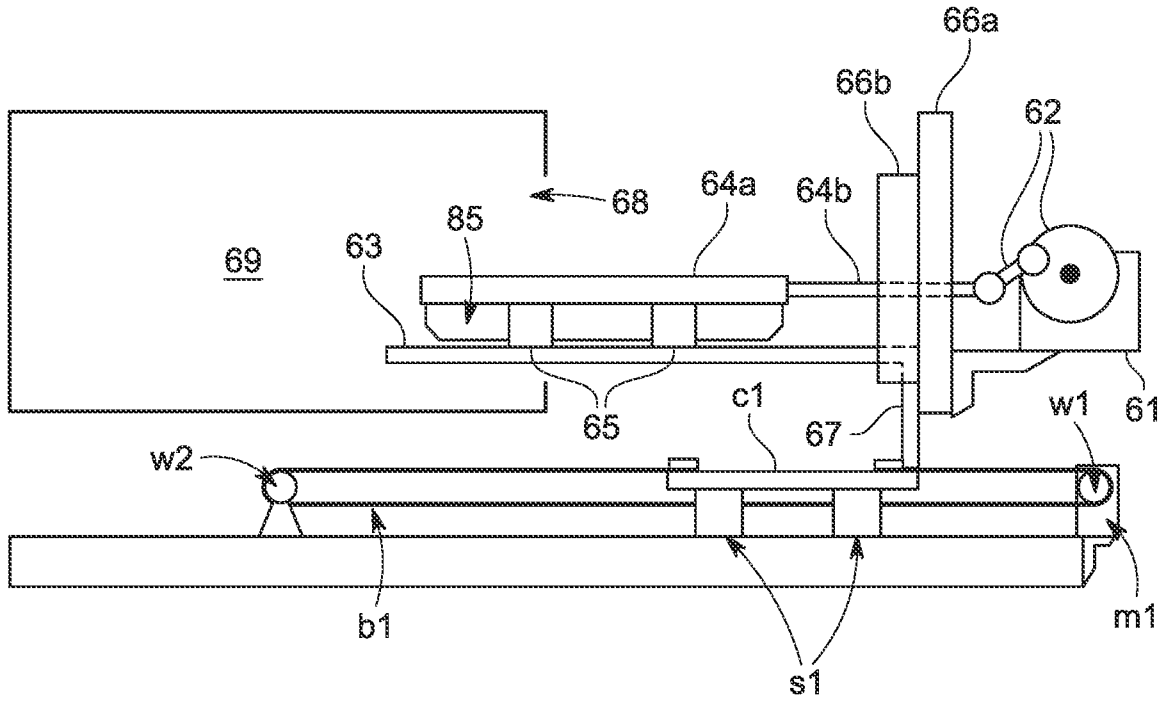

Figure 6C

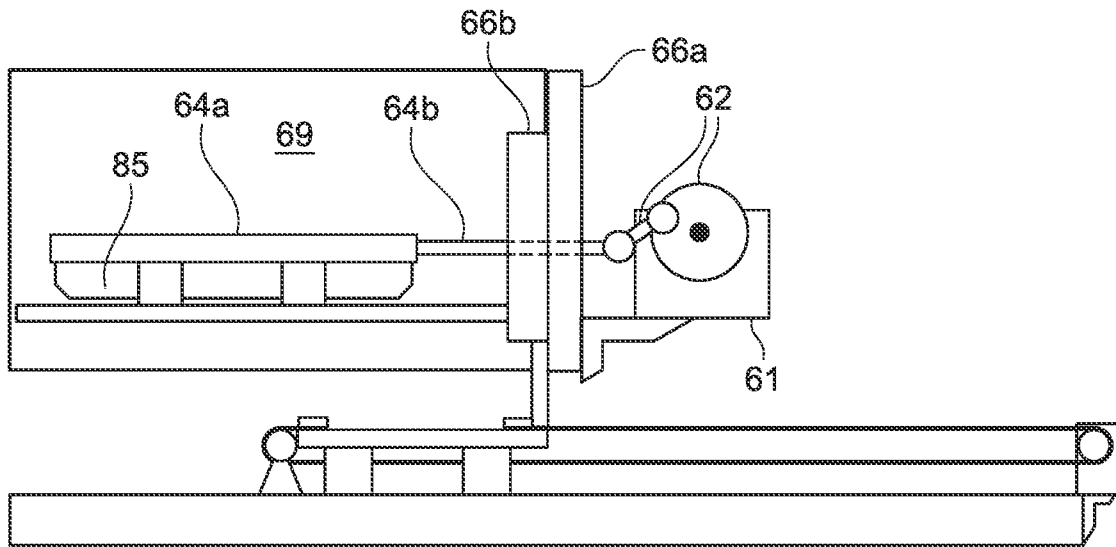

Figure 6D

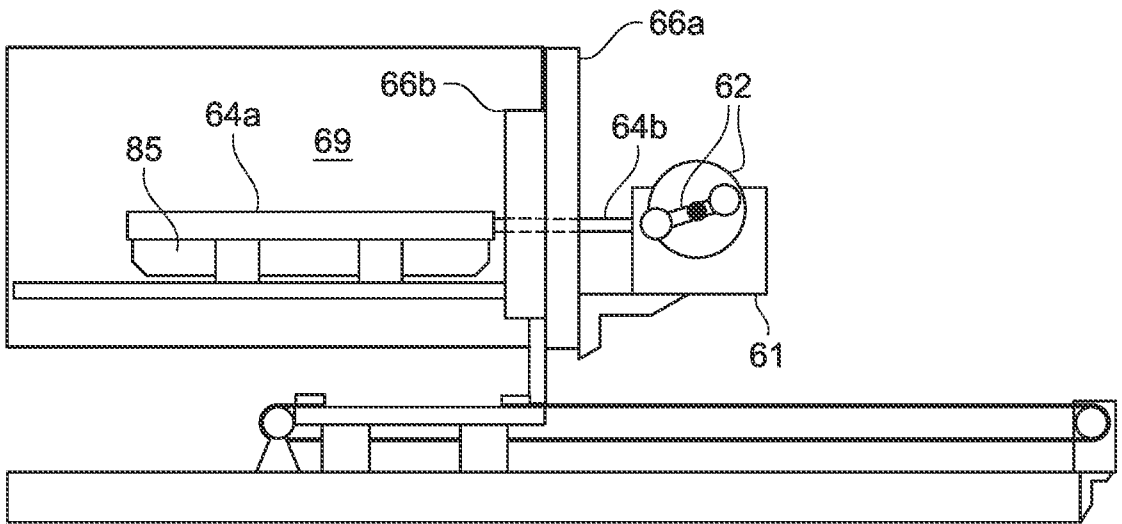

Figure 6E

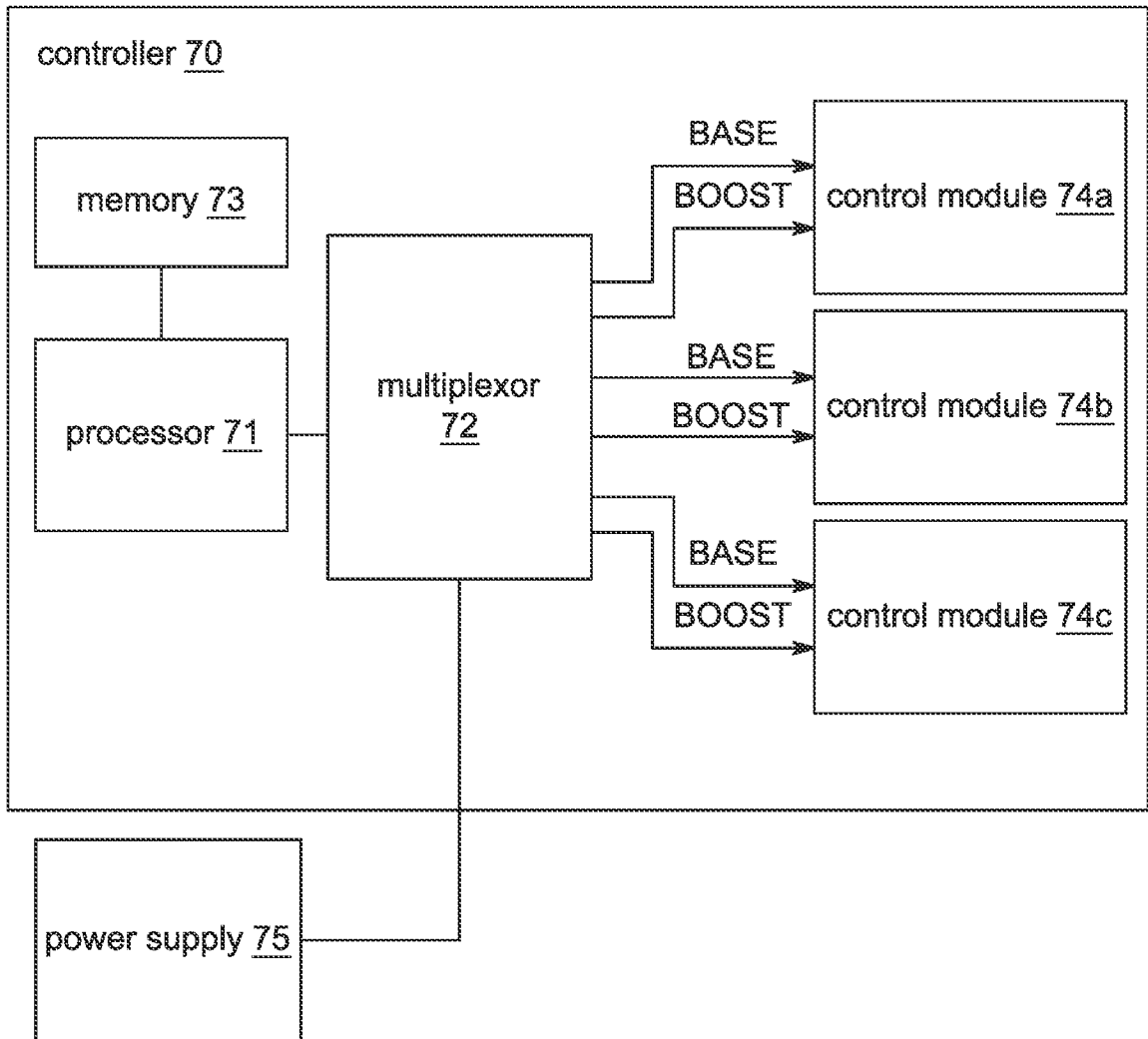

Figure 7

FOOD ENTRY TABLE													
OVEN MODULE	FOOD TYPE	COOK STAGE 1			COOK STAGE 2			COOK STAGE 3					
		From	To	TempBlower	Mag	From	To	TempBlower	Mag	From	To	TempBlower	Mag
impingement	pizza	0	30	400	50	31	50	400	100	51	90	425	80
impingement	sandwich	0	20	425	100	21	50	400	100	51	70	425	60
convection	biscuits	0	50	350	100	51	100	350	100	101	120		
microwave	hot dog	0	50			100	51	70		0	71	90	50

Figure 8A

MAXIMUM CURRENT DRAWN TABLE			
OVEN MODULE	FOOD TYPE	COOK STAGE 1	COOK STAGE 2
impingement	pizza	32	32
impingement	sandwich	32	32
convection	biscuits	28	28
microwave	hot dog	16	0

Figure 8B

CURRENT DRAWN HISTORY TABLE							
OVEN MODULE	FOOD TYPE	Time Unit 1	Time Unit 2	Time Unit 3	Time Unit 4	Time Unit 5	Time Unit 6
impingement	pizza	3.2	5.6	5.6	5.6	5.6	5.6
impingement	sandwich	5.6	5.6	5.6	5.6	5.6	5.6
convection	biscuits	2.8	2.8	3.2	3.2	3.2	3.2

Figure 8C

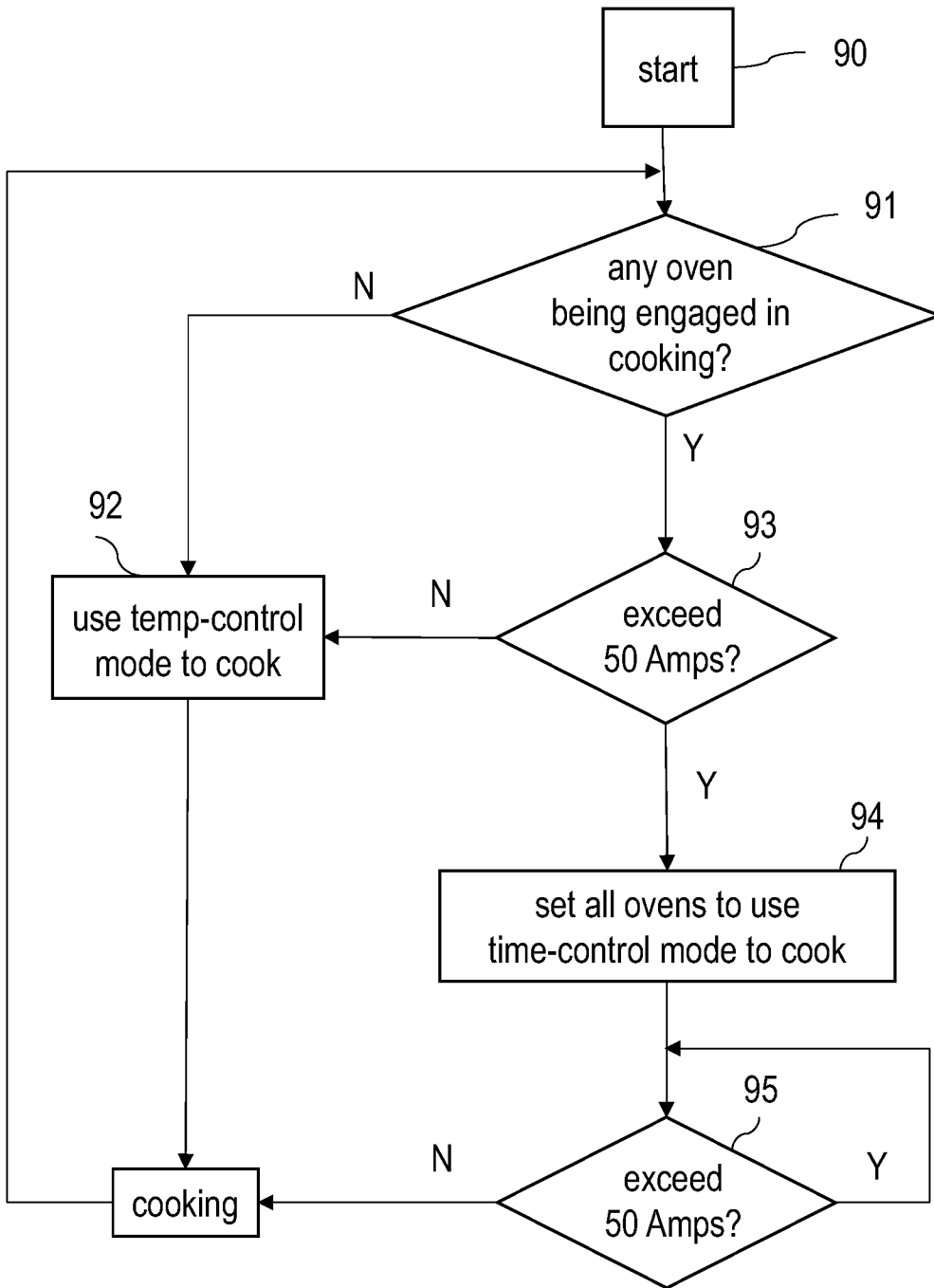

Figure 9