



US010828539B2

(12) **United States Patent**
Stokke et al.

(10) **Patent No.:** **US 10,828,539 B2**

(45) **Date of Patent:** ***Nov. 10, 2020**

(54) **GOLF CLUB HEAD WITH TRANSITION PROFILES TO REDUCE AERODYNAMIC DRAG**

(71) Applicant: **KARSTEN MANUFACTURING CORPORATION**, Phoenix, AZ (US)

(72) Inventors: **Ryan M. Stokke**, Anthem, AZ (US);
Sina Ghods, Phoenix, AZ (US)

(73) Assignee: **Karsten Manufacturing Corporation**, Phoenix, AZ (US)

(*) Notice: Subject to any disclaimer, the term of this patent is extended or adjusted under 35 U.S.C. 154(b) by 0 days.

This patent is subject to a terminal disclaimer.

(21) Appl. No.: **16/022,424**

(22) Filed: **Jun. 28, 2018**

(65) **Prior Publication Data**

US 2018/0318668 A1 Nov. 8, 2018

Related U.S. Application Data

(63) Continuation of application No. 15/233,486, filed on Aug. 10, 2016, now Pat. No. 10,035,048.

(60) Provisional application No. 62/204,911, filed on Aug. 13, 2015, provisional application No. 62/365,889, filed on Jul. 22, 2016.

(51) **Int. Cl.**
A63B 53/04 (2015.01)

(52) **U.S. Cl.**
CPC .. **A63B 53/0466** (2013.01); **A63B 2053/0408** (2013.01); **A63B 2053/0433** (2013.01); **A63B 2053/0437** (2013.01); **A63B 2225/01** (2013.01)

(58) **Field of Classification Search**
CPC **A63B 53/0466**; **A63B 2053/0408**; **A63B 2053/0433**; **A63B 2053/0437**; **A63B 2225/01**

See application file for complete search history.

(56) **References Cited**

U.S. PATENT DOCUMENTS

3,985,363 A	10/1976	Jepson et al.	
6,048,278 A *	4/2000	Meyer	A63B 53/04 473/345
7,785,214 B2	8/2010	Horacek et al.	
8,182,366 B2	5/2012	Horacek et al.	
8,241,142 B2	8/2012	Evans et al.	
8,317,636 B2	11/2012	Evans et al.	
8,845,453 B1	9/2014	Ehlers	
8,864,601 B1	10/2014	Ehlers	
9,144,722 B2 *	9/2015	Schweigert	A63B 53/0466
9,504,886 B2	11/2016	Albertsen et al.	
9,662,545 B2	5/2017	Beach et al.	
9,750,991 B2	9/2017	Chao et al.	

(Continued)

OTHER PUBLICATIONS

International Search Report and Written Opinion dated Oct. 28, 2016 from corresponding PCT Application No. PCT/US2016/46337, filed Aug. 10, 2016.

Primary Examiner — Michael D Dennis

(57) **ABSTRACT**

Embodiments of golf club heads having transition profiles to reduce aerodynamic drag during a swing are described herein. In some embodiments, a golf club head includes a crown transition profile having a first crown radius of curvature, a sole transition profile having a first sole radius of curvature, and a rear transition profile having a rear radius of curvature.

18 Claims, 11 Drawing Sheets

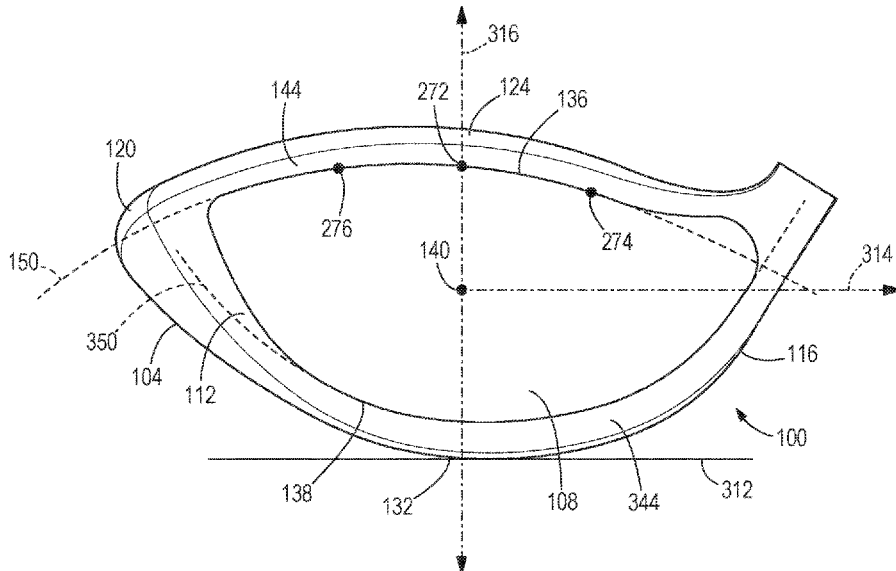

(56)

References Cited

U.S. PATENT DOCUMENTS

2006/0084525	A1*	4/2006	Imamoto	A63B 53/0466 473/345
2012/0322578	A1*	12/2012	Ban	A63B 53/04 473/345
2013/0123040	A1*	5/2013	Willett	A63B 60/00 473/327
2014/0256464	A1*	9/2014	Chao	A63B 53/0466 473/335
2014/0274457	A1*	9/2014	Beach	A63B 53/0466 473/335
2015/0306471	A1*	10/2015	Albertsen	A63B 53/0466 473/327

* cited by examiner

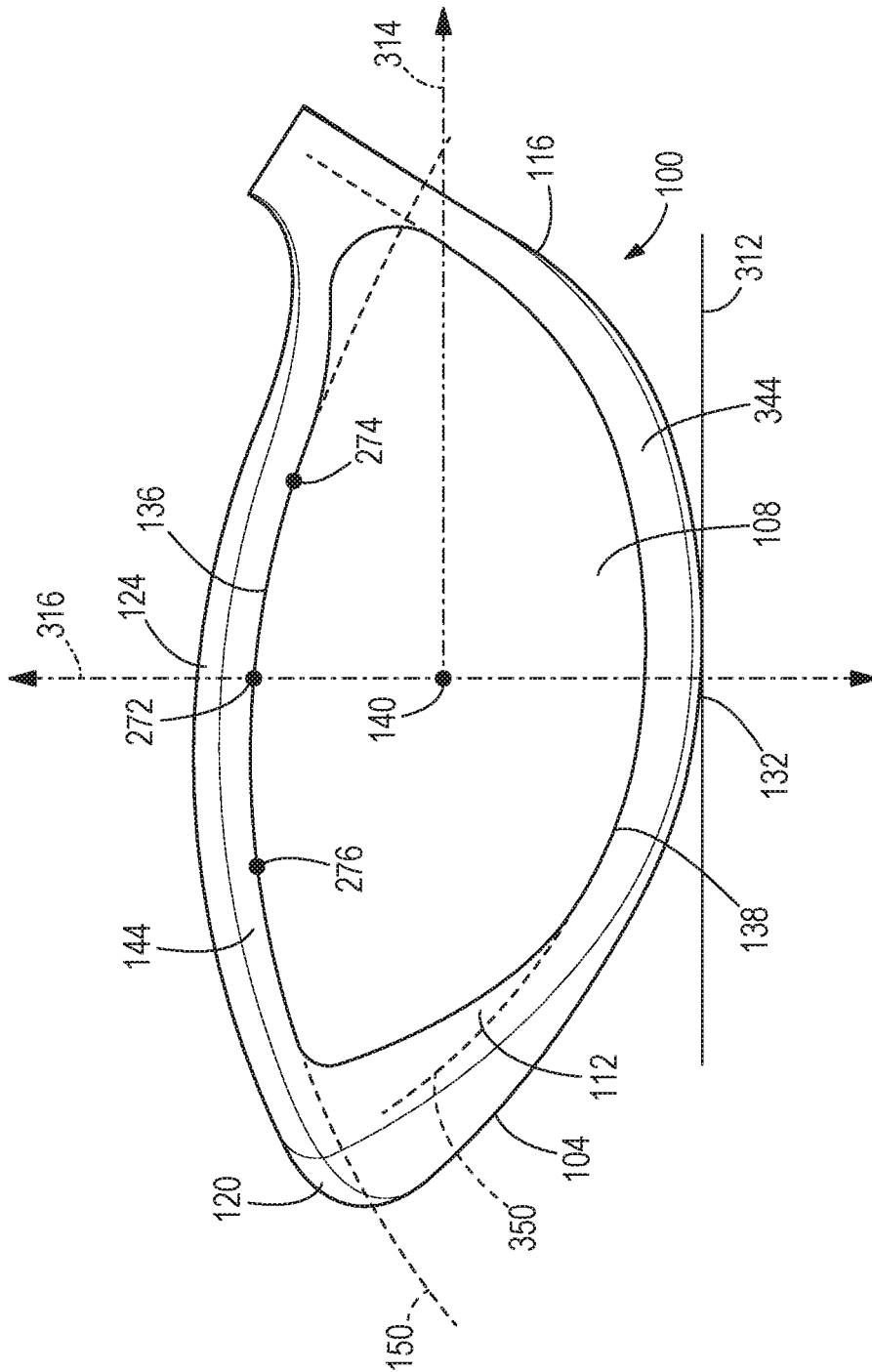

FIG. 1

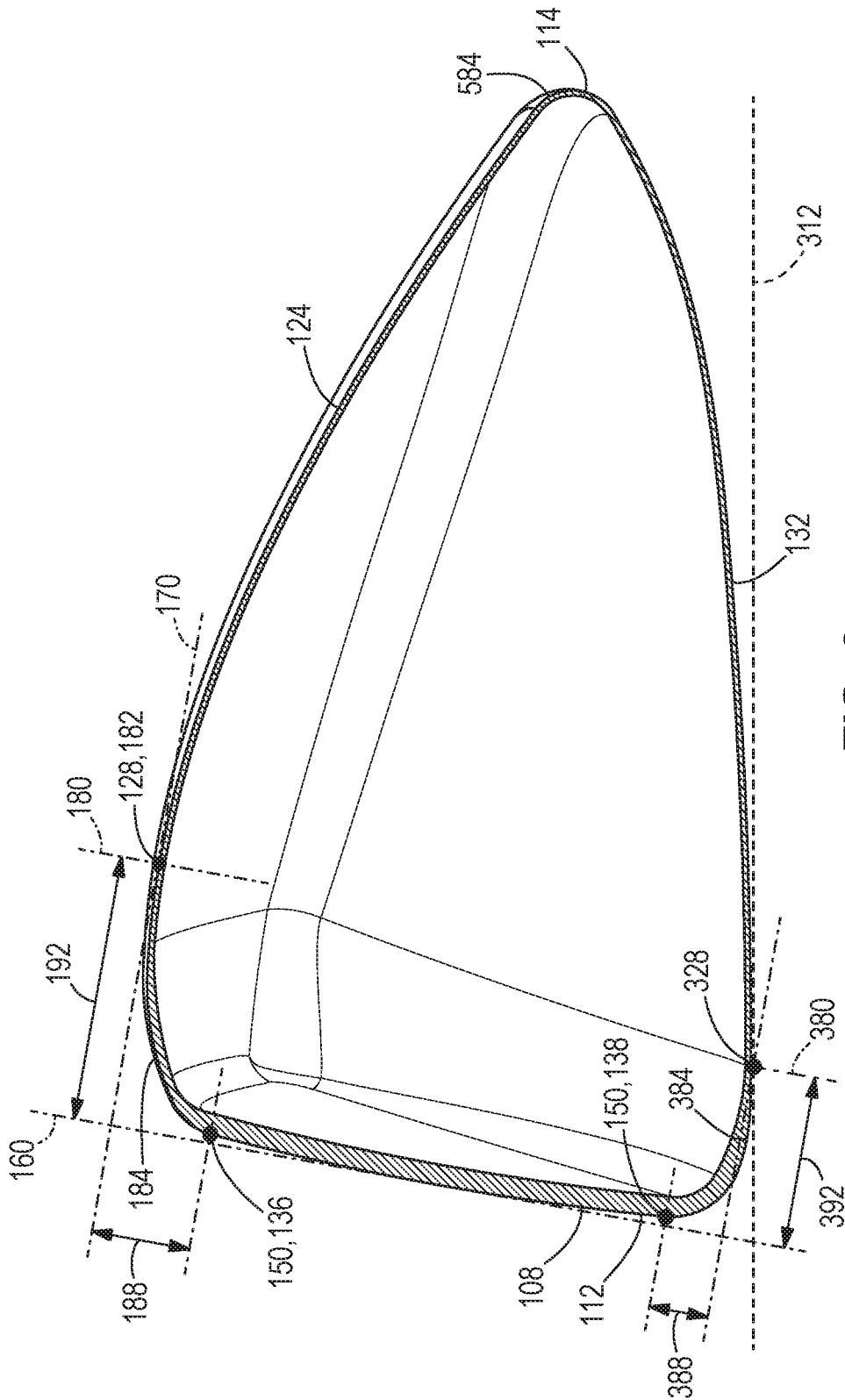

FIG. 2

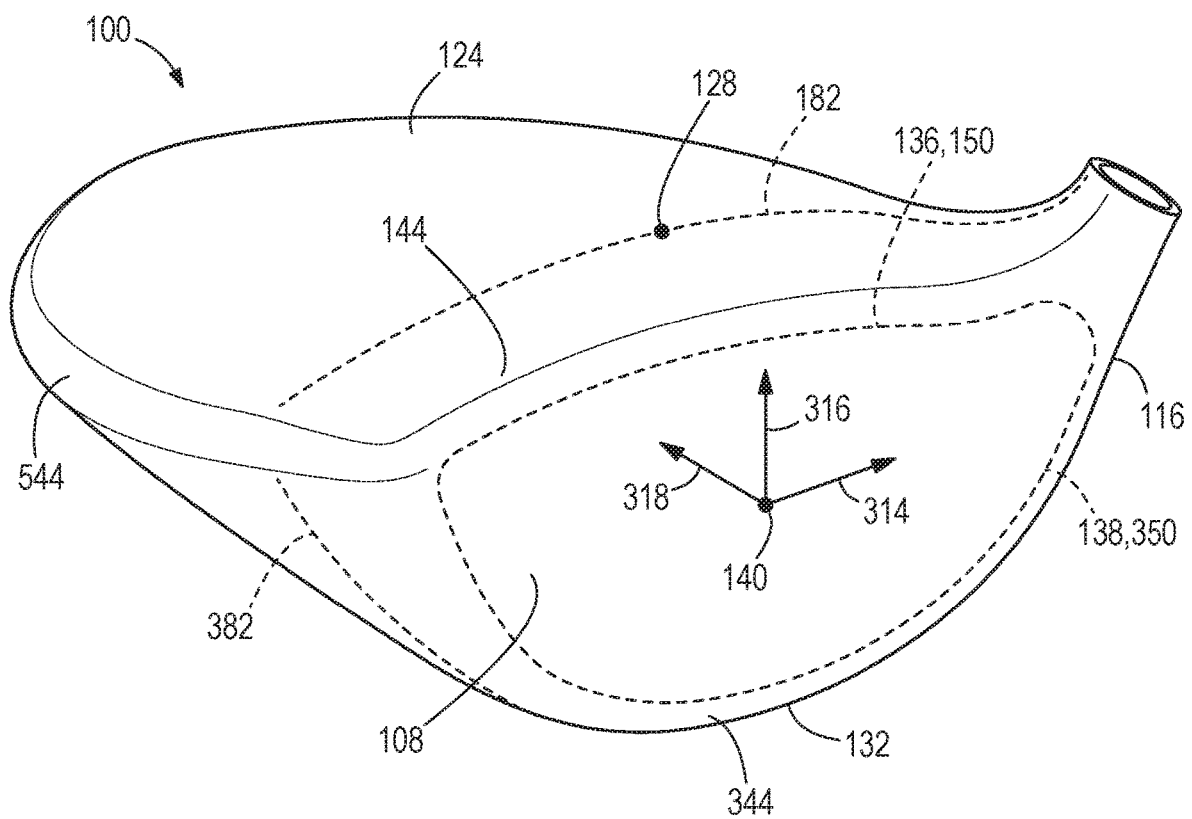

FIG. 3

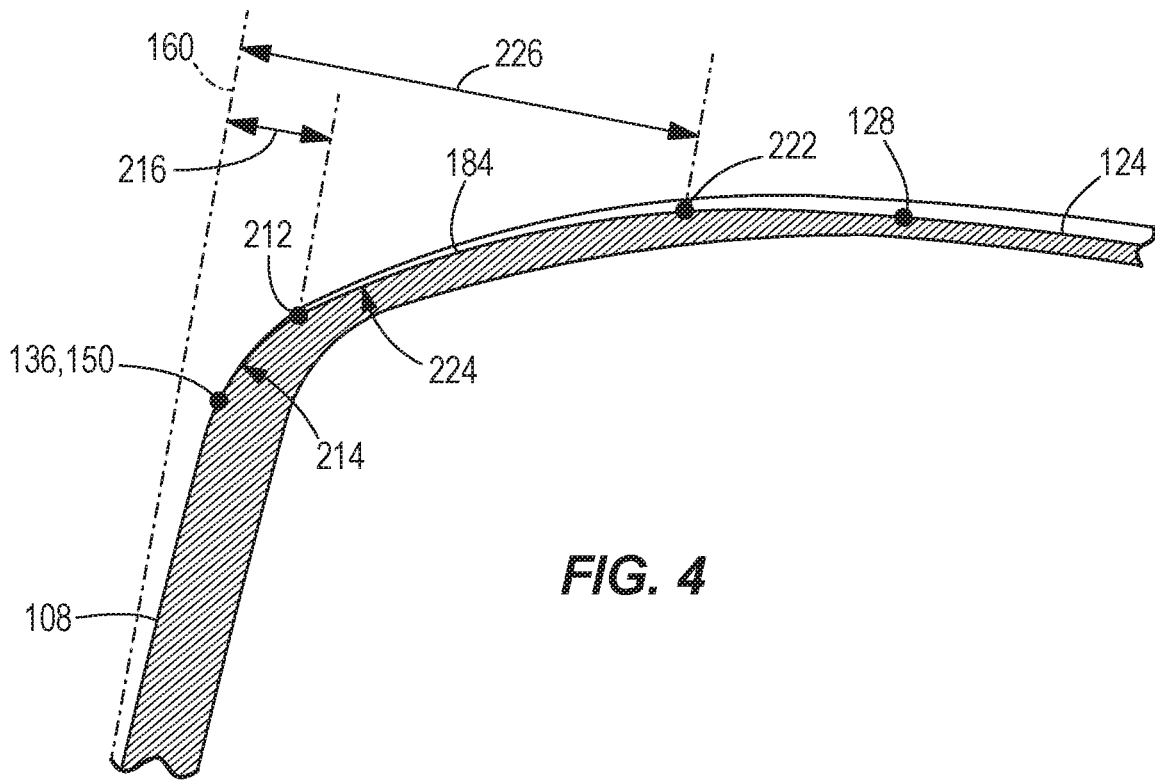

FIG. 4

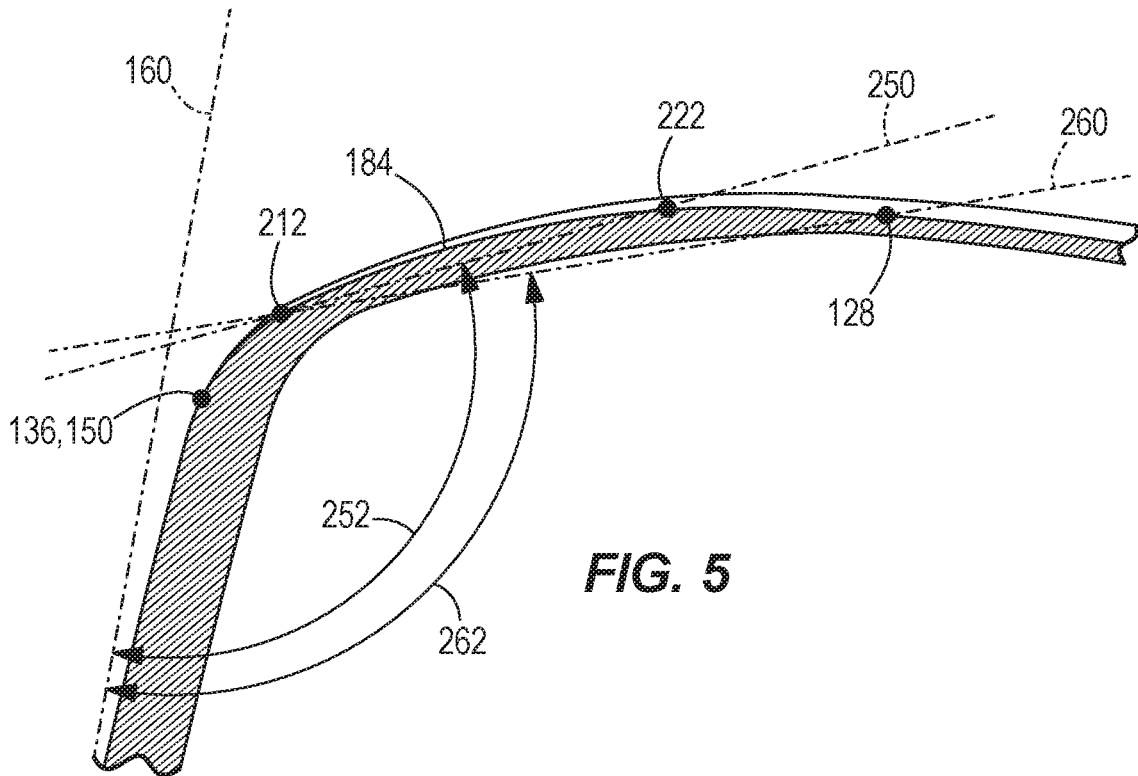

FIG. 5

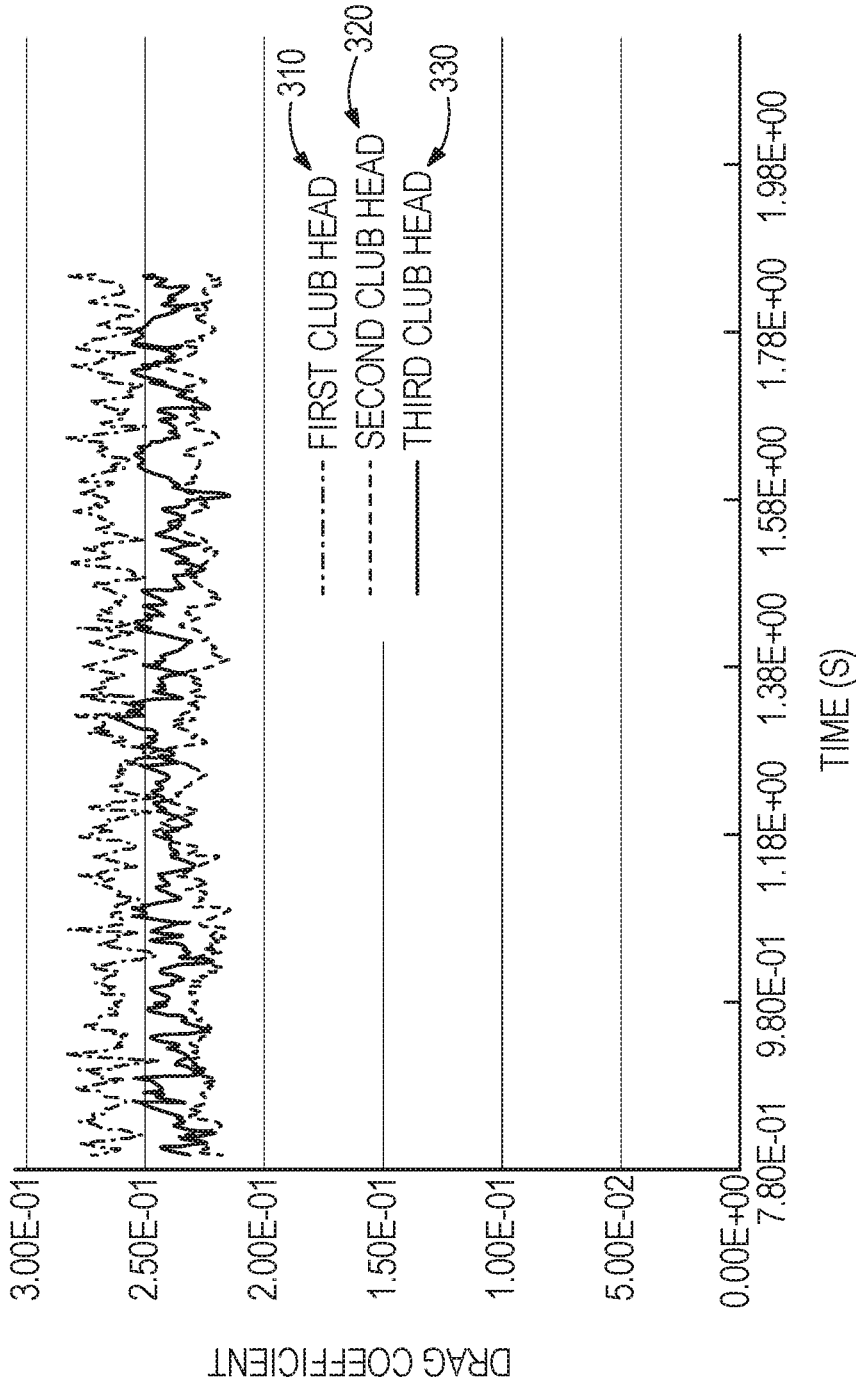

FIG. 6

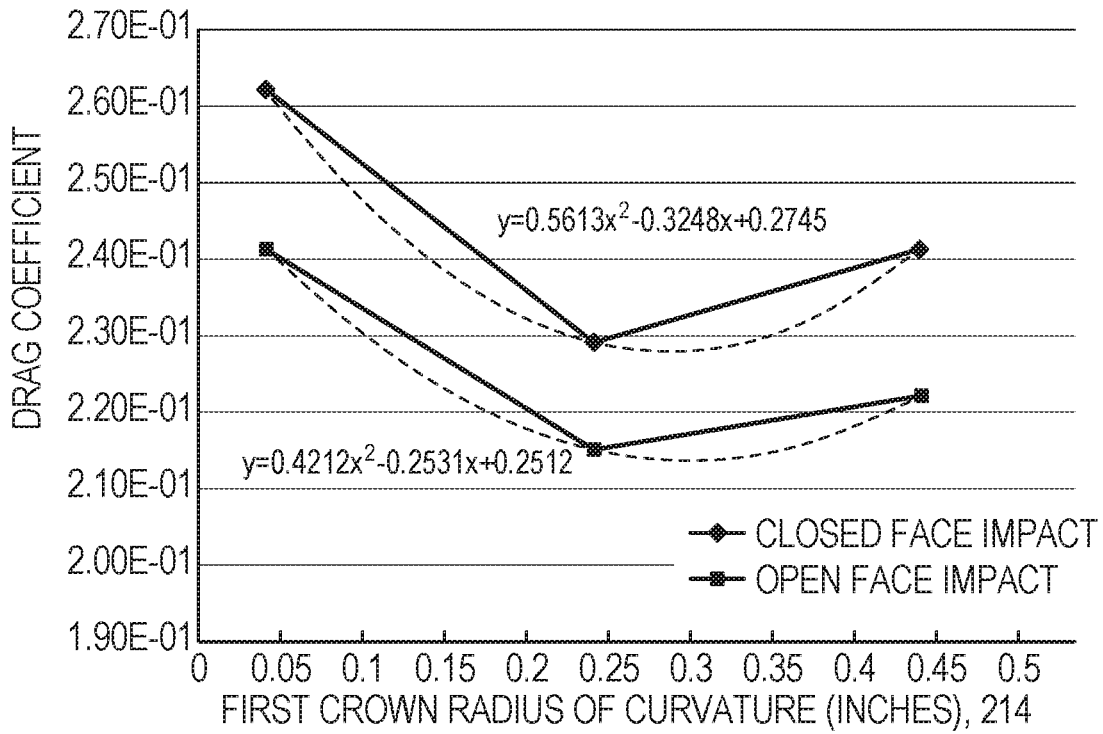

FIG. 7

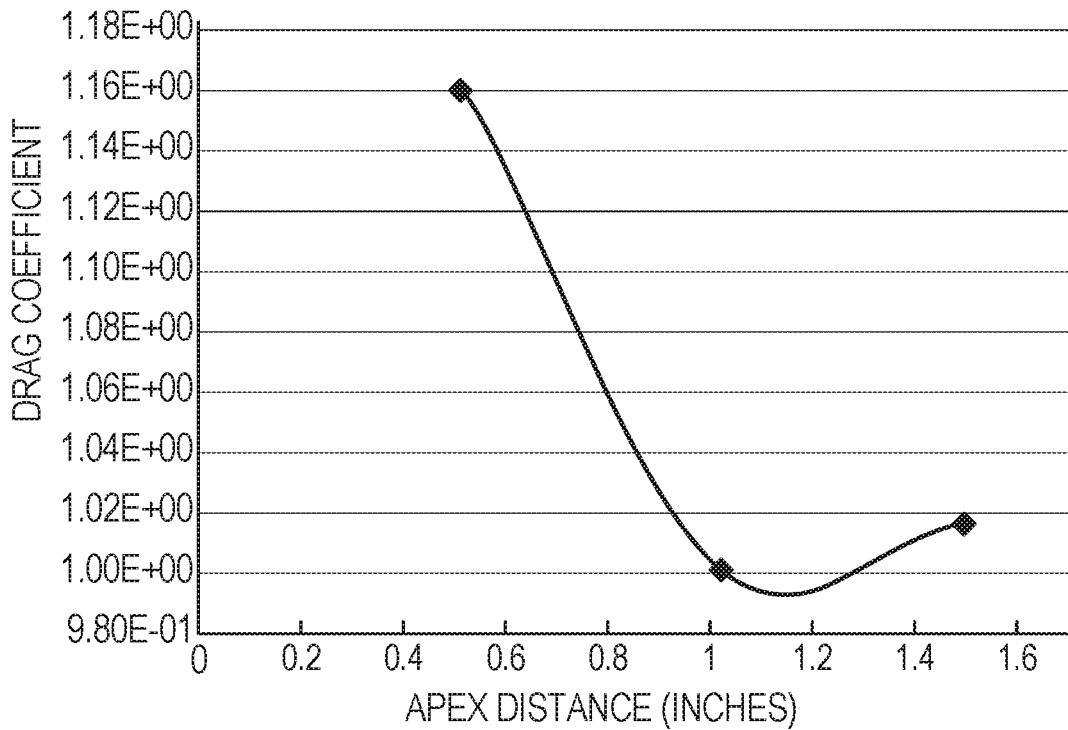

FIG. 8

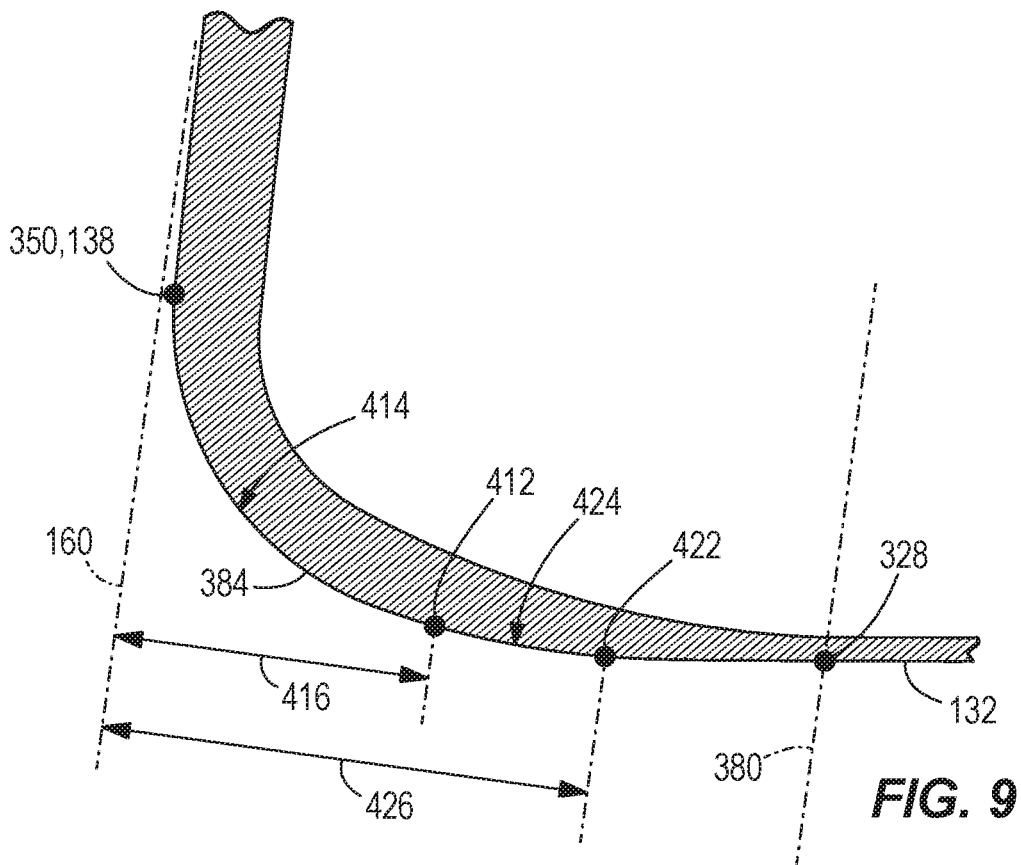

FIG. 9

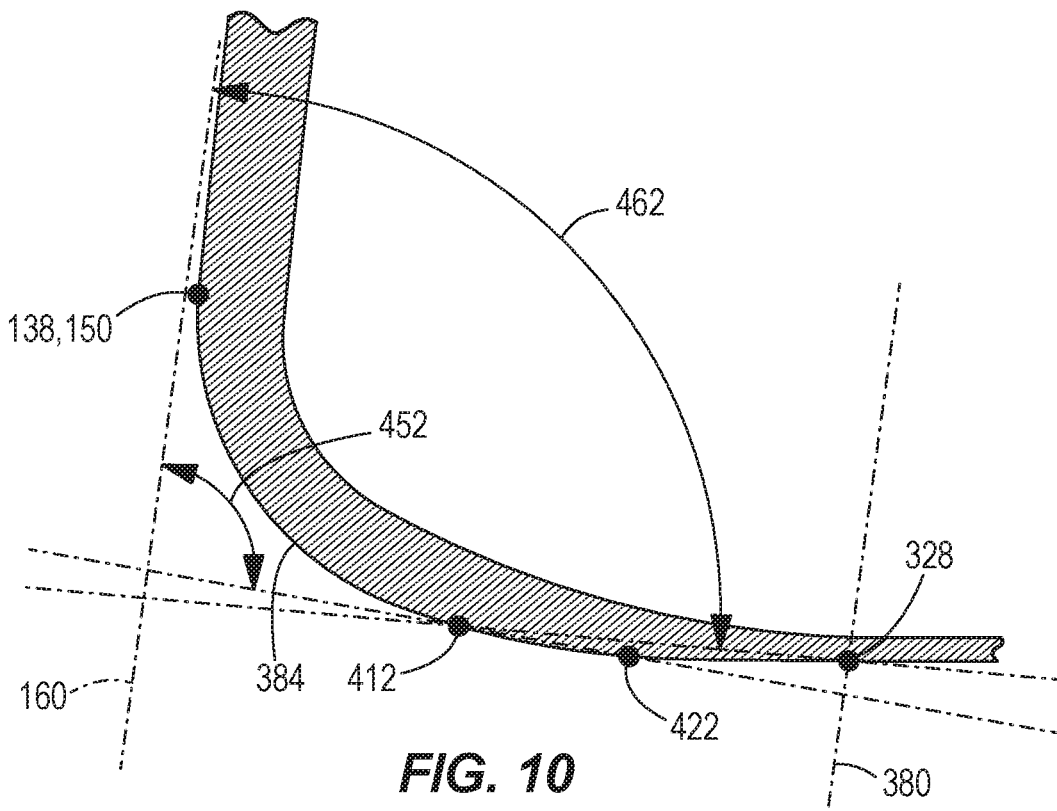

FIG. 10

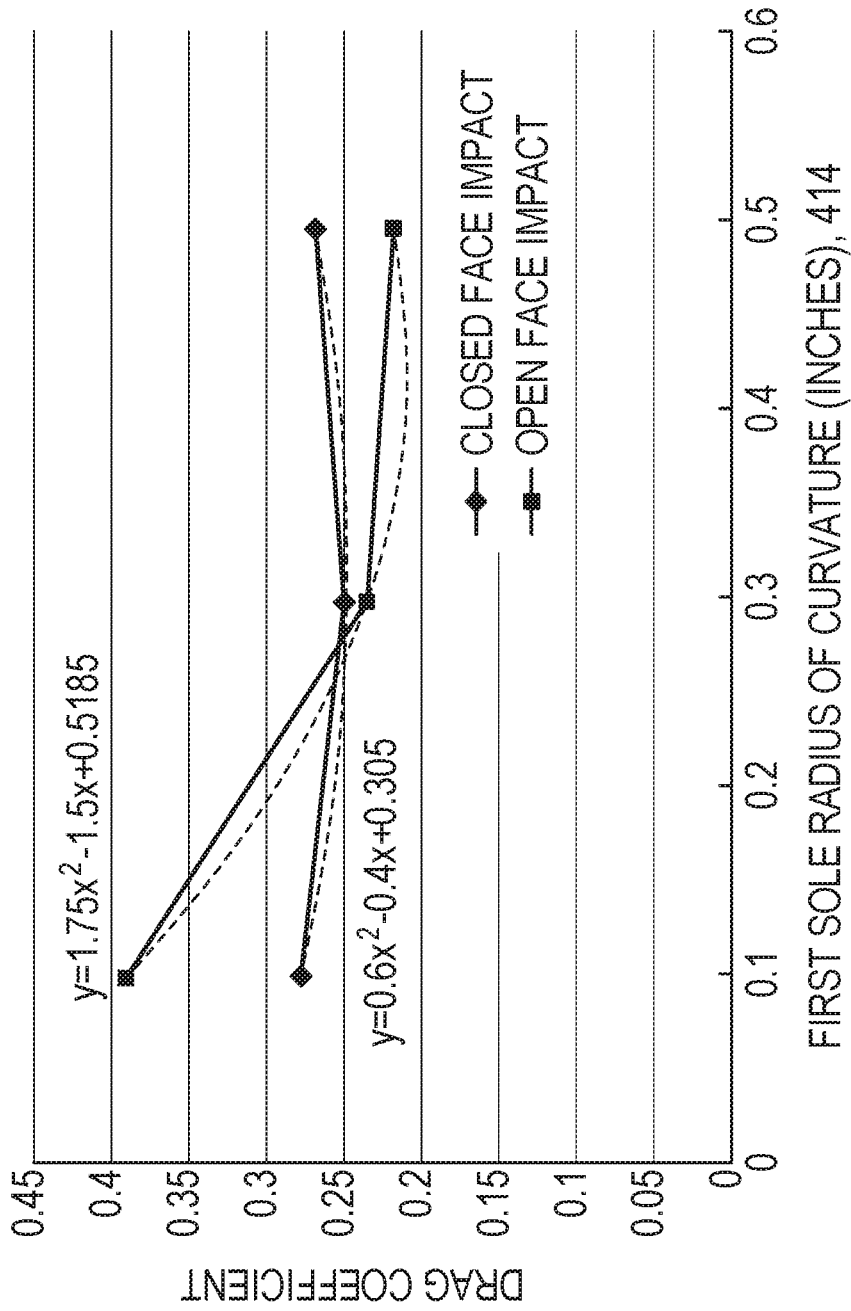

FIG. 11

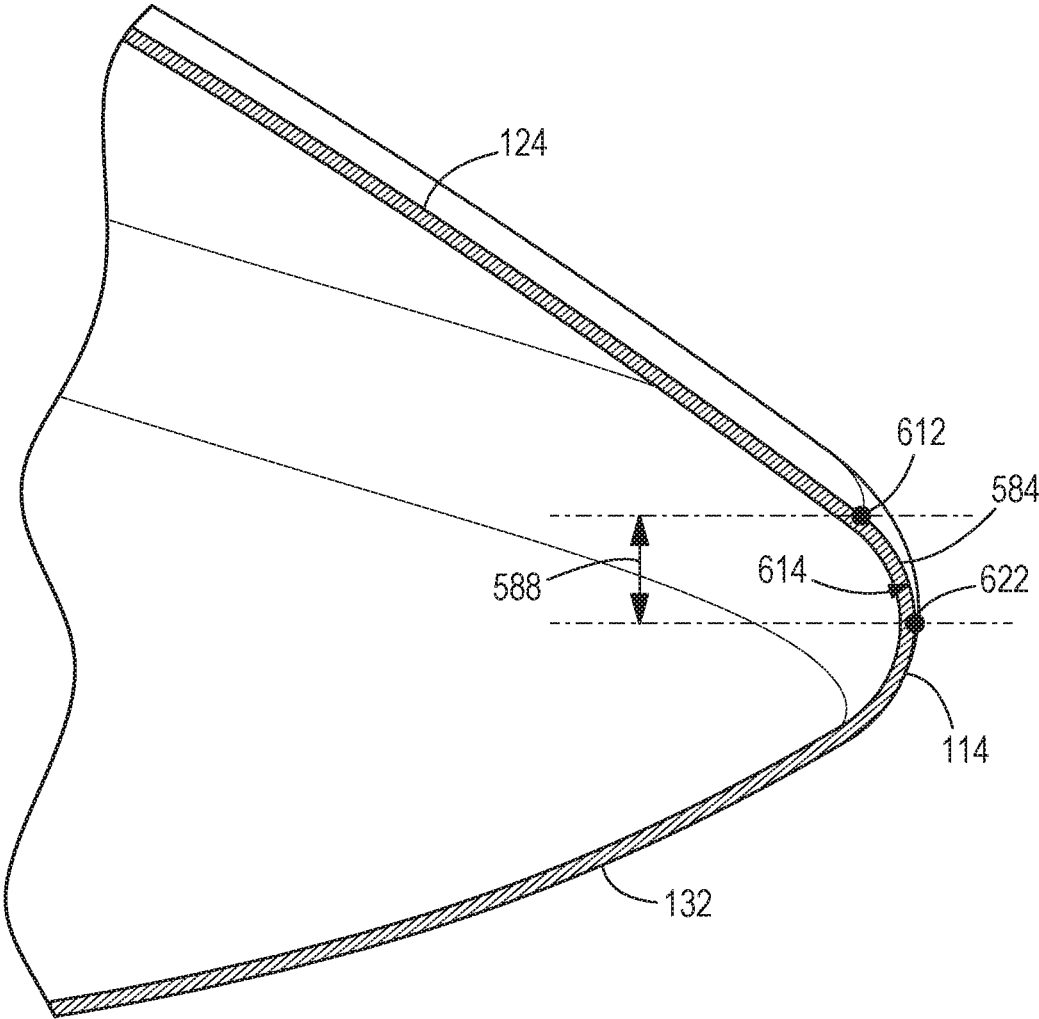

FIG. 12

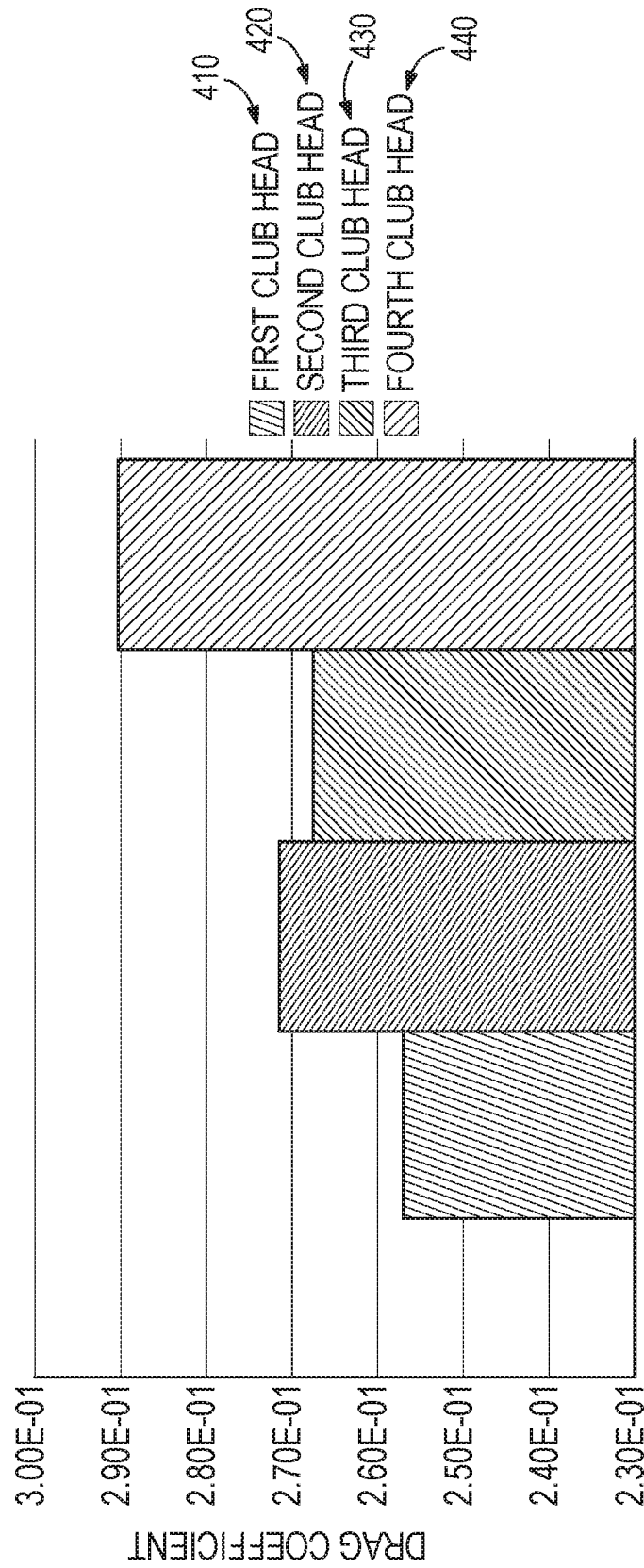
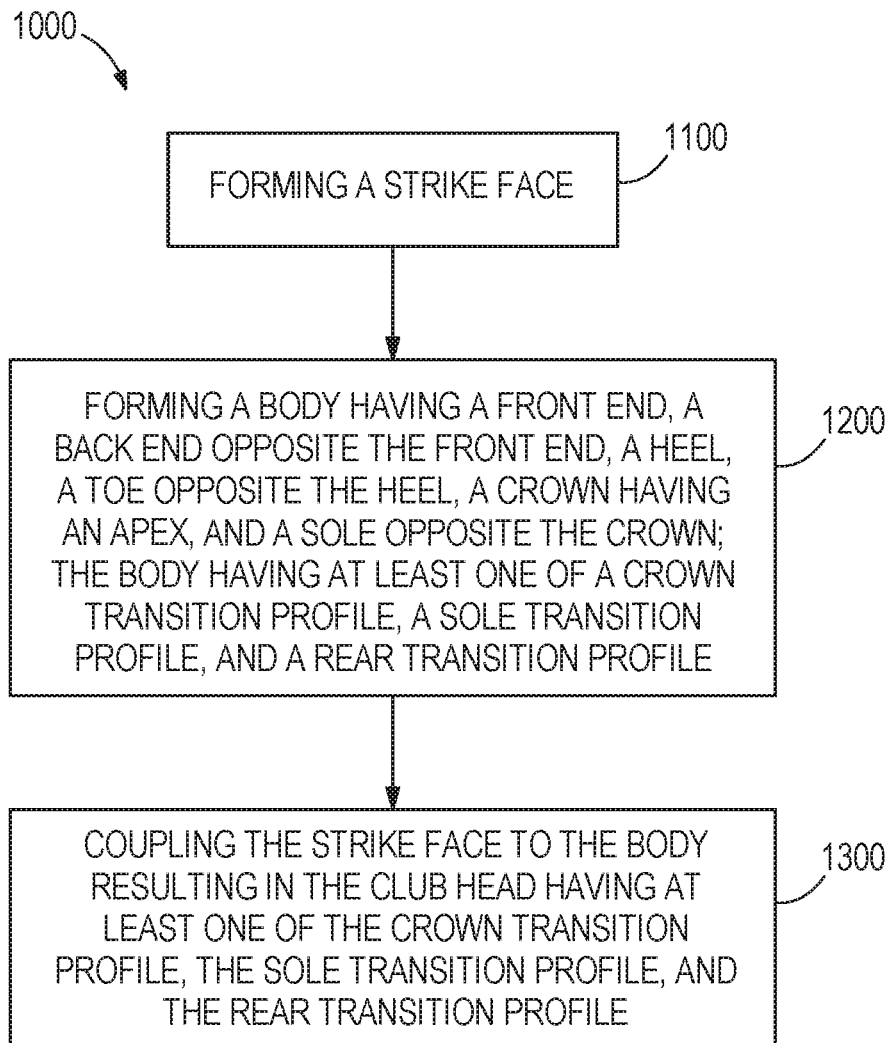

FIG. 13

**FIG. 14**

GOLF CLUB HEAD WITH TRANSITION PROFILES TO REDUCE AERODYNAMIC DRAG

CROSS REFERENCE TO RELATED APPLICATIONS

This is a continuation of U.S. patent application Ser. No. 15/233,486, filed on Aug. 10, 2016, which claims priority to U.S. Provisional Patent Application No. 62/204,911, filed on Aug. 13, 2015, and U.S. Provisional Patent Application No. 62/365,889, filed on Jul. 22, 2016, all of which are incorporated by reference herein in their entirety.

FIELD OF INVENTION

The present disclosure relates to golf club heads. In particular, the present disclosure is related to golf club heads having transition regions to reduce aerodynamic drag during a swing.

BACKGROUND

Golf club manufacturers have designed golf club heads with aerodynamic features to improve the flow of air over and around the golf club head. When air flows around a golf club head during a swing, a wake, or an area of disturbed air flow, is formed behind the club head. In many cases, the wake creates a drag force on the club head, thereby slowing the speed of the golf club head throughout the swing. The transition profiles of a golf club head can be a large contributor to the drag forces on the club head during a swing. Therefore, there is a need in the art for a golf club head having transition regions to reduce the aerodynamic drag on the club head during a swing.

BRIEF DESCRIPTION OF THE DRAWINGS

FIG. 1 is a front view of an exemplary golf club head.

FIG. 2 is a side, cross sectional view of the golf club head in FIG. 1.

FIG. 3 is a front prospective view of the golf club head in FIG. 1.

FIG. 4 is an enlarged side, cross sectional view of the crown transition profile of the golf club head in FIG. 1.

FIG. 5 is another enlarged side cross sectional view of the crown transition profile of the golf club head in FIG. 1.

FIG. 6 illustrates data for the drag coefficient resulting from aerodynamic testing of exemplary golf club heads having varying crown transition profiles.

FIG. 7 illustrates a trend line of the data from the aerodynamic testing of the golf club heads in FIG. 5.

FIG. 8 illustrates aerodynamic data for the drag coefficient resulting from aerodynamic testing of exemplary golf club heads having varying crown transition profile lengths.

FIG. 9 is an enlarged side cross sectional view of the sole transition profile of the golf club head in FIG. 1.

FIG. 10 is another enlarged side cross sectional view of the sole transition profile of the golf club head in FIG. 1.

FIG. 11 illustrates a trend line of data from aerodynamic testing of exemplary golf club heads having varying sole transition profiles.

FIG. 12 is an enlarged side cross sectional view of the rear transition profile of the golf club head in FIG. 1.

FIG. 13 illustrates data from aerodynamic testing of exemplary golf club heads having varying rear transition profiles.

FIG. 14 illustrates a method of manufacturing the golf club head in FIG. 1.

Other aspects of the disclosure will become apparent by consideration of the detailed description and accompanying drawings.

For simplicity and clarity of illustration, the drawing figures illustrate the general manner of construction, and descriptions and details of well-known features and techniques may be omitted to avoid unnecessarily obscuring the present disclosure. Additionally, elements in the drawing figures are not necessarily drawn to scale. For example, the dimensions of some of the elements in the figures may be exaggerated relative to other elements to help improve understanding of embodiments of the present disclosure.

The same reference numerals in different figures denote the same elements.

DETAILED DESCRIPTION

Described herein are embodiments of a golf club head having various transition profiles to reduce aerodynamic drag on the club head during a swing. Transition profiles contribute significantly to the aerodynamic drag on a golf club head. In many embodiments, the club head includes a crown transition profile, a sole transition profile, and a rear transition profile to maximize the reduction of drag resulting from the transition regions of the club head. In many embodiments, the crown transition profile includes a first crown radius of curvature between approximately 0.18-0.30 inches (0.46-0.76 cm), the sole transition profile includes a first sole radius of curvature between approximately 0.3-0.5 inches (0.76-1.27 cm), and the rear transition profile includes a rear radius of curvature between approximately 0.10-0.25 inches (0.25-0.64 cm) to reduce aerodynamic drag on the club head.

Various embodiments of the golf club head are described herein having transition regions to reduce aerodynamic drag include a golf club head having a body and a strike face. The strike face includes a top edge, a bottom edge, and a geometric center. The strike face defines a loft plane positioned tangent to the strike face extending through the geometric center. The body includes a front end, a back end opposite the front end, a heel, a toe opposite the heel, a crown having an apex and a crown transition profile, a sole having a lowest point and a sole transition profile, and a back end or skirt having rear transition profile. The crown transition profile includes a first crown radius of curvature extending from the top edge of the strike face to a first crown transition point, wherein the first crown radius of curvature is between approximately 0.18 inches and 0.30 inches (0.46 cm-0.76 cm). The sole transition profile includes a first sole radius of curvature extending from the bottom edge of the strike face to a first sole transition point, wherein the first sole radius of curvature is between approximately 0.30 inches and 0.50 inches (0.76 cm-1.27 cm). The rear transition profile includes a rear radius of curvature between approximately 0.10 inches and 0.25 inches (0.25 cm-0.64 cm).

Some embodiments include a golf club comprising a golf club head and a shaft coupled to the golf club head. The club head includes a body and a strike face. The strike face includes a top edge, a bottom edge, and a geometric center. The strike face defines a loft plane positioned tangent to the strike face extending through the geometric center. The body includes a front end, a back end opposite the front end, a heel, a toe opposite the heel, a crown having an apex and a crown transition profile, a sole having a lowest point and a

sole transition profile, and a back end or skirt having rear transition profile. The crown transition profile includes a first crown radius of curvature extending from the top edge of the strike face to a first crown transition point, wherein the first crown radius of curvature is between approximately 0.18 inches (0.46 cm) and 0.30 inches (0.76 cm). The sole transition profile includes a first sole radius of curvature extending from the bottom edge of the strike face to a first sole transition point, wherein the first sole radius of curvature is between approximately 0.30 inches (0.76 cm) and 0.50 inches (1.27 cm). The rear transition profile includes a rear radius of curvature between approximately 0.10 inches (0.25 cm) and 0.25 inches (0.64 cm).

The terms “first,” “second,” “third,” “fourth,” and the like in the description and in the claims, if any, are used for distinguishing between similar elements and not necessarily for describing a particular sequential or chronological order. It is to be understood that the terms so used are interchangeable under appropriate circumstances such that the embodiments described herein are, for example, capable of operation in sequences other than those illustrated or otherwise described herein. Furthermore, the terms “include,” and “have,” and any variations thereof, are intended to cover a non-exclusive inclusion, such that a process, method, system, article, device, or apparatus that comprises a list of elements is not necessarily limited to those elements, but may include other elements not expressly listed or inherent to such process, method, system, article, device, or apparatus.

The terms “left,” “right,” “front,” “back,” “top,” “bottom,” “over,” “under,” and the like in the description and in the claims, if any, are used for descriptive purposes and not necessarily for describing permanent relative positions. It is to be understood that the terms so used are interchangeable under appropriate circumstances such that the embodiments of the apparatus, methods, and/or articles of manufacture described herein are, for example, capable of operation in other orientations than those illustrated or otherwise described herein.

As defined herein, “spline method” refers to a method of determining the location where the curvature of a surface changes. For example, the spline method can be used to determine where the curvature of the front end of a club head deviates from the bulge and roll of the strike face. The spline method can be implemented by imposing a spline onto the curved surface with an interval such that the spline indicates where a significant change in curvature begins.

Before any embodiments of the disclosure are explained in detail, it is to be understood that the disclosure is not limited in its application to the details of construction and the arrangement of components set forth in the following description or illustrated in the following drawings. The disclosure is capable of other embodiments and of being practiced or of being carried out in various ways.

FIGS. 1-2 illustrate a golf club head 100 including a body 104 and a strike face 108. The body 104 includes a front end 112, a back end 114 opposite the front end 112, a heel 116, a toe 120 opposite the heel 116, a crown 124 having an apex 128, and a sole 132 opposite the crown 124.

Referring to FIG. 1, the strike face 108 includes a top edge 136, a bottom edge 138, and a geometric center 140. The top edge 136 extends along the front end 112 of the strikeface 108 near the crown 124 where the curvature deviates from the bulge and roll of the strike face 108. The bottom edge 138 extends along the front end 112 of the strikeface 108 near the sole 132 where the curvature deviates from the bulge and roll of the strike face 108. In some embodiments,

the spline method can be used to determine where the curvature deviates from the bulge and roll of the strike face 108 at the top edge 136 or at the bottom edge 138.

The geometric center 140 of the strike face 108 can be located at a geometric midpoint of the strike face 108. In the same or other examples, the geometric center 140 also can be centered with respect to an engineered impact zone, which can be defined by a region of grooves of the strike face 108. As another approach, the geometric center 140 of the strike face 108 can be located in accordance with the definition of a golf governing body such as the United States Golf Association (USGA). For example, geometric center 140 of the strike face 108 can be determined in accordance with Section 6.1 of the USGA’s Procedure for Measuring the Flexibility of a Golf Clubhead (USGA-TPX3004, Rev. 1.0.0, May 1, 2008) (available at <http://www.usga.org/equipment/testing/protocols/Procedure-For-Measuring-The-Flexibility-Of-A-Golf-Club-Head/>) (the “Flexibility Procedure”).

Further referring to FIG. 1, the geometric center 140 of the strike face 108 defines an origin of a coordinate system having an x-axis 314, a y-axis 316, and a z-axis 318 (FIG. 3). The x-axis 314 extends through the geometric center 140 of the strike face 108 from near the heel 116 to near the toe 120 of the club head 100 in a direction parallel to the ground plane 312. The y-axis 316 extends through the geometric center 140 of the strike face 108 from near the crown 124 to near the sole 132 of the club head 100 in a direction perpendicular to the ground plane 312. The z-axis 318 (FIG. 3) extends through the geometric center 140 of the strike face 108 from the front end 112 to the back end 114 of the club head 100 in a direction parallel to the ground plane 312.

The golf club head 100 described herein may be any type of golf club head. In the illustrated embodiment, the golf club head is illustrated as a driver-type golf club head. In other embodiments, the golf club head may be a wood-type golf club head, a hybrid-type golf club head, an iron-type golf club head, or any other type of golf club head. Further, the golf club head 100 described herein may be part of a golf club having a shaft and a grip (not shown).

FIGS. 1-2 illustrate the club head 100 in an address position relative to a ground plane 312. In the address position, a hosel axis, extending centrally through the hosel, is positioned at a 60 degree angle to the ground plane when viewed from a front view (FIG. 1). Further, the club head 100 includes a loft plane 160 that extends tangent to the geometric center 140 of the strike face 108, and a plurality of transition regions including a crown transition region 144, a sole transition region 344, and a rear transition region 544, described in further detail below.

I. Crown Transition Region

Referring to FIG. 1, the crown transition region 144 extends between the strike face 108 and the crown 124 of the club head 100, from near the heel 116 to near the toe 120. The crown transition region 144 of the golf club head 100 is further described herein in relation to various reference planes and axes, as described below.

Further referring to FIG. 1, the golf club head 100 includes a curved axis 150 that extends along the front end 112 of the body 104 from the heel 116 to the toe 120. In the illustrated embodiment, the curved axis 150 extends along the top edge 136 of the strike face 108. In other embodiments, the curved axis 150 may be offset from the top edge 136 of the strike face 108 toward the crown 124. The curved axis 150 may be offset from the top edge 136 of the strike face 108 by a constant distance moving from the heel 116 to the toe 120, or the curved axis 150 may be offset from the

top edge **136** of the strike face **108** by a varying distance moving from the heel **116** to the toe **120**. For example, the curved axis **150** may be offset from the top edge **136** of the strike face **108** by a greater or lesser distance near the center, the heel **116**, the toe **120**, or any combination of the described positions on the club head **100**.

Referring to FIGS. **2** and **3**, the golf club head **100** further includes a crown plane **170** and an apex plane **180**. The crown plane **170** extends through the apex **128** of the crown **124** perpendicular to the loft plane **160**. The apex plane **180** extends through the apex **128** of the crown **124** parallel to the loft plane **160**. The intersection of the apex plane **180** with the crown **124** of the club head **100** further defines a curved crown axis **182**.

Referring to FIGS. **1-2**, the crown transition region **144** extends from the top edge **136** on the front end **112** of the club head **100** to the apex plane **180**, along the crown **124** of the club head **100**. The crown transition region **144** includes a crown transition profile **184** when viewed from a side cross sectional view taken along a plane defined by the y-axis **316** and z-axis **318** (FIG. **3**). In these embodiments, the side cross sectional view of the crown transition profile **184** can be taken at any point along the club head **100** from near the heel **116** to near the toe **120**.

i. Height and Length of the Crown Transition Profile

Referring to FIGS. **2** and **3**, the crown transition profile **184** includes a height **188** and a length **192**. The height **188** of the crown transition profile **184** is the distance from the top edge **136** to the crown axis **182** in a direction parallel to the loft plane **160**. The length **192** of the crown transition profile **184** is the perpendicular distance from the loft plane **160** to the apex plane **180**.

Referring to FIG. **2**, in the illustrated embodiment, the length **192** of the crown transition profile **184** ranges from approximately 1.13-1.34 inches (2.87-3.4 cm). In other embodiments, the length **192** of the crown transition profile **184** may range from 0.90-1.75 inches (2.29-4.45 cm). For example, the length **192** of the crown transition profile **184** may be approximately 0.90 inches (2.29 cm), 0.95 inches (2.41 cm), 1.00 inches (2.54 cm), 1.05 inches (2.67 cm), 1.10 inches (2.79 cm), 1.15 inches (2.92 cm), 1.20 inches (3.05 cm), 1.25 inches (3.18 cm), 1.30 inches (3.30 cm), 1.35 inches (3.43 cm), 1.40 inches (3.56 cm), 1.45 inches (3.68 cm), 1.50 inches (3.81 cm), 1.55 inches (3.94 cm), 1.60 inches (4.06 cm), 1.65 inches (4.19 cm), 1.70 inches (4.32 cm), or 1.75 inches (4.45 cm).

Further referring to FIG. **2**, in the illustrated embodiment, the height **188** of the crown transition profile **184** ranges from approximately 0.410-0.470 inches (1.04-1.19 cm). In other embodiments, the height **188** of the crown transition profile **184** may range from 0.30-0.60 inches (0.76-1.52 cm). For example, the height **188** of the crown transition profile **184** may be approximately 0.30 inches (0.76 cm), 0.35 inches (0.89 cm), 0.40 inches (1.02 cm), 0.45 inches (1.14 cm), 0.50 inches (1.27 cm), 0.55 inches (1.40 cm), or 0.60 inches (1.52 cm).

The club head **100** further includes a first ratio of the length **192** to the height **188** of the crown transition profile **184**. In the illustrated embodiment, the first ratio of the crown transition profile **184** ranges from approximately 2.75-3.0. In other embodiments, the first ratio of the crown transition profile **184** may range from approximately 2.5-3.25. Further, in other embodiments, the first ratio of the crown transition profile **184** may be any value less than approximately 3.50, less than approximately 3.25, or less than approximately 3.0. For example, the first ratio of the

crown transition profile **184** may be less than or equal to approximately 3.50, 3.25, 3.00, 2.75, or 2.50.

The aerodynamic drag on a club head decreases as the first ratio of the crown transition profile approaches a value of 1.0 (i.e. as the length of the crown transition profile approaches the height of the crown transition profile, or as the height of the crown transition profile approaches the length of the crown transition profile). The first ratio of the crown transition profile **184** of the club head **100** described herein is less than the first ratio of the crown transition profile of other known golf club heads. Therefore, the club head **100** described herein has less aerodynamic drag, and therefore increased swing speeds and ball distance than other known golf club heads.

ii. Transition Points and Radii of Curvature of the Crown Transition Profile

Referring to FIG. **4**, the crown transition profile **184** further includes more than one radius of curvature and more than one transition point. The transition points indicate a change in the radius of curvature of the crown transition profile **184**. In the illustrated embodiment, the crown transition profile **184** includes a first crown transition point **212**, a second crown transition point **222**, a first crown radius of curvature **214**, and a second crown radius of curvature **224**. The first crown transition point **212** is offset from the loft plane **160** by a first offset distance **216**. The second crown transition point **222** is offset from the loft plane **160** by a second offset distance **226**. The second offset distance **226** is greater than the first offset distance **216**. The first crown radius of curvature **214** extends from the top edge **136** to the first crown transition point **212**. The second crown radius of curvature **224** extends from the first crown transition point **212** to the second crown transition point **222**.

Referring to FIG. **4**, in the illustrated embodiment, the first offset distance **216** and the second offset distance **226** are substantially constant from the heel **116** to the toe **120** of the club head **100**. In other embodiments, the first offset distance **216** may vary from the heel **116** to the toe **120** of the club head **100**. For example, the first offset distance **216** may be greater toward the heel **116** of the club head **100**, toward the toe **116** of the club head **100**, in the center of the club head **100**, or in any combination of the above described positions. The first offset distance **216** may vary from the heel **116** to the toe **120** according to any profile, such as, for example, linear, parabolic, quadratic, exponential, or any other profile.

In other embodiments, the second offset distance **226** may vary from the heel **116** to the toe **120** of the club head **100**. For example, the second offset distance **226** may be greater toward the heel **116** of the club head **100**, toward the toe **120** of the club head **100**, in the center of the club head **100**, or in any combination of the above described positions. The second offset distance **226** may vary from the heel **116** to the toe **120** according to any profile, such as, for example, linear, parabolic, quadratic, exponential, or any other profile.

In the illustrated embodiment, the crown transition profile **184** has a first crown radius of curvature **214** of approximately 0.24 inches (0.61 cm). In other embodiments, the first crown radius of curvature **214** may range from approximately 0.18 to 0.30 inches (0.46 to 0.76 cm). Further, in other embodiments, the first crown radius of curvature **214** can be less than 0.40 inches (1.02 cm), less than 0.375 inches (0.95 cm), less than 0.35 inches (0.89 cm), less than 0.325 inches (0.83 cm), or less than 0.30 inches (0.76 cm). For example, the first crown radius of curvature **214** may be approximately 0.18 inches (0.46 cm), 0.20 inches (0.51 cm),

0.22 inches (0.66 cm), 0.24 inches (0.61 cm), 0.26 inches (0.66 cm), 0.28 inches (0.71 cm), or 0.30 inches (0.76 cm).

Referring to FIG. 4, in the illustrated embodiment, the first crown radius of curvature **214** and the second crown radius of curvature **224** are substantially constant from the heel **116** to the toe **120** of the club head **100**. In other embodiments, the first crown radius of curvature **214** may vary from the heel **116** to the toe **120** of the club head **100**. For example, the first crown radius of curvature **214** may be greater toward the heel **116** of the club head **100**, toward the toe **120** of the club head **100**, in the center of the club head **100**, or in any combination of the above described positions. The first crown radius of curvature **214** may vary from the heel **116** to the toe **120** according to any profile, such as, for example, linear, parabolic, quadratic, exponential, or any other profile.

Further, in other embodiments, the second crown radius of curvature **224** may vary from the heel **116** to the toe **120** of the club head **100**. For example, the second crown radius of curvature **224** may be greater toward the heel **116** of the club head **100**, toward the toe **120** of the club head **100**, in the center of the club head **100**, or in any combination of the above described positions. The second crown radius of curvature **224** may vary from the heel **116** to the toe **120** according to any profile, such as, for example, linear, parabolic, quadratic, exponential, or any other profile.

In the illustrated embodiment, the crown transition profile **184** has two transition points and two radii of curvature. In other embodiments, the crown transition profile **184** may include any number of transition points, and any number of radii of curvature. For example, the crown transition profile **184** may include one, two, three, four, five, six, seven, eight, nine, ten, or any other number of transition points. For further example, the crown transition profile **184** may include one, two, three, four, five, six, seven, eight, nine, ten, or any other number of radii of curvature.

The aerodynamic drag reduction due to the first crown radius of curvature **214** was determined using wind tunnel testing for various exemplary club heads having varied first crown radii of curvature. Referring to FIGS. 6-7, a first club head **310** having a first crown radius of curvature of approximately 0.04 inches (0.10 cm), a second club head **320** having a first crown radius of curvature of approximately 0.24 inches (0.61 cm), and a third club head **330** having a first crown radius of curvature of approximately 0.44 inches (1.12 cm) were tested in a wind tunnel. The lowest aerodynamic drag, measured using the drag coefficient, was observed in the second club head **320** having the first crown radius of curvature of approximately 0.24 inches (0.61 cm) for both an open and closed face at impact. Further, in other embodiments, the lowest aerodynamic drag can be observed with a first crown radius of curvature between 0.20 inches (0.51 cm) and 0.28 inches (0.71 cm).

FIGS. 6 and 7 illustrates that increasing the first crown radius of curvature does not always result in reduced drag. For example, increasing the first crown radius of curvature may result in an increase or a decrease in drag. Similarly, decreasing the first crown radius of curvature does not always result in increased drag. For example, decreasing the first crown radius of curvature may result in an increase or a decrease in drag. In the illustrated example, when the first crown radius of curvature is increased from 0.04 inches (0.10 cm) to 0.24 inches (0.61 cm), the drag is reduced by a greater extent than when the first crown radius of curvature is increased from 0.04 inches (0.10 cm) to 0.44 inches (1.12 cm). Further, when the first crown radius of curvature is increased from 0.24 inches (0.61 cm) to 0.44 inches (1.12

cm), the drag on the club head **100** increases. Accordingly, an optimum first crown radius of curvature exists to reduce aerodynamic drag on the club head **100** for both an open and closed face at impact. FIG. 7 illustrates a curve fit to the data in FIG. 6 to determine the first crown radius of curvature of between approximately 0.20 inches (0.51 cm) and 0.28 inches (0.71 cm) results in the greatest drag reduction on the club head **100**.

iii. Angles of the Crown Transition Profile

Referring to FIG. 5, the crown transition profile **184** can be further characterized by the position of the first and the second crown transition points **212**, **222** in relation to the apex **128** and the loft plane **160**. When viewed from a side cross sectional view taken along a plane defined by the y-axis **316** and z-axis **318**, the crown transition profile **184** includes a first axis **250**, a second axis **260**, a first angle **252**, and a second angle **262**. The first axis **250** extends through the first crown transition point **212** and the second crown transition point **222**, and forms the first angle **252** with the loft plane **160**. The second axis **260** extends through the first crown transition point **212** and the apex **128**, and forms the second angle **262** with the loft plane **160**. In the illustrated embodiment, the first angle **252** of the crown transition profile **184** ranges from approximately 111.0-114.5 degrees and the second angle **262** of the crown transition profile **184** ranges from 103.5-105 degrees. In other embodiments, the first angle **252** of the crown transition profile **184** may range from approximately 100-125 degrees, and the second angle **262** of the crown transition profile **184** may range from 90-120 degrees. In other embodiments, the second angle **262** of the crown transition profile **184** may be any value greater than 98 degrees, greater than 100 degrees, or greater than 102 degrees.

iv. Aerodynamic Improvements Resulting from the Crown Transition Profile

The golf club head **100** having the crown transition profile **184**, as described herein, was compared to a control golf club head during wind tunnel testing. The control golf club head had a crown transition profile with a first ratio of approximately 3.50-3.52, a length of approximately 1.12-1.19 inches (2.84-3.02 cm), a height of approximately 0.32-0.34 inches (0.81-0.86 cm). Aerodynamic drag was determined for both golf club heads using the same testing parameters (e.g. wind speed, club head position). The club head **100** having the crown transition profile **184**, as described herein, experienced 34.0-39.4% less drag than the control golf club head, with an average drag reduction of approximately 35.9% for an average club head speed at impact. Reduced aerodynamic drag of the club head **100** resulting from the crown transition profile **184** results in increased swing speeds and ball distance.

v. Apex Distance

Referring back to FIGS. 2 and 3, the apex **128** of the club head **100** is offset from the loft plane **160** by an apex distance measured in a direction perpendicular to the loft plane **160**. In the illustrated embodiment, the apex distance is approximately 1.0 inch (2.54 cm). In other embodiments, the apex distance can range from approximately 0.8 inches (2.03 cm) to 1.4 inches (3.56 cm), from approximately 0.9 inches (2.29 cm) to approximately 1.3 inches (3.3 cm), or from approximately 1.0 inch (2.54 cm) to 1.2 inches (3.05 cm). For example, the apex distance can be approximately 0.9 inches (2.29 cm), 1.0 inches (2.54 cm), 1.1 inches (2.79 cm), 1.2 inches (3.05 cm), 1.3 inches (3.30 cm), or 1.4 inches (3.56 cm).

In many embodiments, aerodynamic drag reduction can result from varying the apex distance. The aerodynamic drag

reduction due to the apex distance was determined using wind tunnel testing for various exemplary club heads having varied apex distances. Referring to FIG. 8, a first club head having an apex distance of approximately 0.05 inches (1.27 cm), a second club head having an apex distance of approximately 1.0 inches (2.54 cm), and a third club head having an apex distance of approximately 1.5 inches (3.81 cm) were tested in a wind tunnel. The lowest aerodynamic drag, measured using the drag coefficient, was observed in the second club head having the apex distance of approximately 1.0 inches (2.54 cm).

FIG. 8 illustrates that increasing the apex distance does not always result in reduced drag. For example, increasing the apex distance may result in an increase or a decrease in drag. Similarly, decreasing the apex distance does not always result in increased drag. For example, decreasing the apex distance may result in an increase or a decrease in drag. In the illustrated example, when the apex distance is increased from 0.5 inches (1.27 cm) to 1.0 inches (2.54 cm), the drag is reduced by a greater extent than when the apex distance is increased from 0.5 inches (2.17 cm) to 1.5 inches (3.81 cm). Further, when the apex distance is increased from 1.0 inches (2.54 cm) to 1.5 inches (3.81 cm), the drag on the club head 100 increases. Accordingly, an optimum apex distance exists to reduce aerodynamic drag on the club head 100.

vi. Heel to Toe Radius of Curvature

Referring back to FIG. 1, in addition to the crown transition profile 184, the club head 100 further includes a heel to toe radius of curvature positioned on the front end 112 extending from near the heel 116 to near the toe 120 when viewed from a front view. In many embodiments, increasing the heel to toe radius of curvature can further reduce the aerodynamic drag of the club head 100 during a swing.

The heel to toe radius of curvature can be determined using a three point method. The three point method includes positioning three points along the top edge 136 on the front end 112 of the club head 100. The three points include a first point 272 positioned along the top edge 136 in line with the geometric center 140 of the strike face 108 in the direction of the x-axis 316, a second point 274 positioned along the top edge 136 offset from the geometric center 140 of the strike face 108 in the direction of the x-axis 316 by 1.0 inch (2.54 cm) toward the heel 116 of the club head 100, and a third point 276 positioned along the top edge 136 offset from the geometric center 140 of the strike face 108 in the direction of the x-axis 316 by 1.0 inch (2.54 cm) toward the toe 120 of the club head 100. The radius of a circle formed to intersect the first, the second, and the third points defines the heel to toe radius of curvature of the front end 112 of the club head 100.

In the illustrated embodiment, the heel to toe radius of curvature extends along the entire top edge 136 of the strike face 108 from near the heel 116 to near the toe 120. In other embodiments, the heel to toe radius of curvature can extend along a portion of the top edge 136 of the strike face 108.

Increasing the heel to toe radius of curvature can reduce aerodynamic drag on a golf club head during a swing. In the illustrated embodiment, the heel to toe radius of curvature is approximately 6.325 inches (16.07 cm) to reduce aerodynamic drag compared to a similar club head having a lower heel to toe radius of curvature. In other embodiments, aerodynamic drag on the club head 100 can be reduced with a heel to toe radius of curvature greater than approximately 4.9 inches (12.4 cm), greater than approximately 5.2 inches (13.2 cm), greater than approximately 5.5 inches (14.0 cm),

greater than approximately 5.8 inches (14.7 cm), greater than approximately 6.0 inches (15.2 cm), greater than approximately 6.1 inches (15.5 cm), greater than approximately 6.2 inches (15.7 cm), greater than approximately 6.3 inches (16.0 cm), greater than approximately 6.4 inches (16.3 cm), greater than approximately 6.5 inches (16.5 cm), greater than approximately 6.6 inches (16.8 cm), greater than approximately 6.7 inches (17.0 cm), greater than approximately 6.8 inches (17.3 cm), greater than 6.9 inches (17.5 cm), or greater than approximately 7.0 inches (17.8 cm). Further, in other embodiments, aerodynamic drag on the club head 100 can be reduced with a heel to toe radius of curvature between approximately 5.0-6.5 inches (12.7-16.5 cm), between approximately 5.25-6.75 inches (13.3-17.1 cm), between approximately 5.5-7.0 inches (14.0-17.8 cm), between approximately 5.75-7.25 inches (14.6-18.4 cm), between 6.0-7.5 inches (15.2-19.1 cm), or between 6.25-7.75 inches (15.9-19.7 cm).

The increased heel to toe radius of curvature results in a flattened shape of the crown transition region 144 in a heel to toe direction when viewed from a front view, compared to a similar club head having a lower heel to toe radius of curvature. The flattened shape maintains laminar flow and reduces turbulent flow over the heel and toe regions of the crown to reduce the aerodynamic drag on the club head 100.

II. Sole Transition Region

Referring to FIG. 1, the sole transition region 344 extends between the strike face 108 and the sole 132 of the club head 100, from near the heel 116 to near the toe 120. The sole transition region 344 of the golf club head 100 is further described herein in relation to various reference planes and axes, as described below.

Further referring to FIG. 1, the golf club head 100 includes a curved axis 350 that extends along the front end 112 of the body 104 from the heel 116 to the toe 120. In the illustrated embodiment, the curved axis 350 extends along the bottom edge 138 of the strike face 108. In other embodiments, the curved axis 350 may be offset from the bottom edge 138 of the strike face 108 toward the sole 132. The curved axis 350 may be offset from the bottom edge 138 of the strike face 108 by a constant distance moving from the heel 116 to the toe 120, or the curved axis 350 may be offset from the top edge 138 of the strike face 108 by a varying distance moving from the heel 116 to the toe 120. For example, the curved axis 350 may be offset from the bottom edge 138 of the strike face 108 by a greater or lesser distance near the center, the heel 116, the toe 120, or any combination of the described positions on the club head 100.

Referring to FIG. 2, the golf club head 100 further includes a sole plane 380. The sole plane 380 extends through a lowest point of the sole 328 parallel to the loft plane 160. The intersection of the sole plane 380 with the sole 132 of the club head 100 further defines a curved sole axis 382.

Referring to FIGS. 2, 9, and 10, the sole transition region 344 extends from the bottom edge 138 on the front end 112 of the club head 100 to the sole plane 380, along the sole 132 of the club head 100. The sole transition region 344 includes a sole transition profile 384 when viewed from a side cross sectional view taken along a plane defined by the y-axis 316 (FIG. 2) and z-axis 318 (FIG. 3). In these embodiments, the side cross sectional view can be taken at any point along the club head 100 from near the heel 116 to near the toe 120.

i. Height and Length of the Sole Transition Profile

Referring to FIG. 2, the sole transition profile 384 includes a height 388 and a length 392. The height 388 of the sole transition profile 384 is the distance from the bottom

edge **138** to the curved sole axis in a direction parallel to the loft plane **160**. The length **392** of the sole transition profile **384** is the perpendicular distance from the loft plane **160** to the sole plane **380**.

Referring to FIG. 2, in the illustrated embodiment, the length **392** of the sole transition profile **384** ranges from approximately 0.55-0.65 inches (1.40-1.65 cm). In other embodiments, the length **392** of the sole transition profile **384** may range from approximately 0.10-1.25 inches (0.25-3.18 cm) or from approximately 0.30-0.90 inches (0.76-2.29 cm). For example, the length **392** of the sole transition profile **384** may be approximately 0.10 inches (0.25 cm), 0.20 inches (0.51 cm), 0.30 inches (0.76 cm), 0.40 inches (1.02 cm), 0.45 inches (1.14 cm), 0.50 inches (1.27 cm), 0.55 inches (1.40 cm), 0.60 inches (1.52 cm), 0.65 inches (1.65 cm), 0.70 inches (1.48 cm), 0.75 inches (1.91 cm), 0.80 inches (2.03 cm), 0.90 inches (2.29 cm), 1.0 inches (2.54 cm), 1.1 inches (2.79 cm), or 1.2 inches (3.05 cm).

Further referring to FIG. 2, in the illustrated embodiment, the height **388** of the sole transition profile **384** ranges from approximately 0.23-0.31 inches (0.58-0.79 cm). In other embodiments, the height **388** of the sole transition profile **384** may range from approximately 0.05-0.4 inches (0.13-1.02 cm). For example, the height **388** of the sole transition profile **384** may be approximately 0.10 inches (0.25 cm), 0.15 inches (0.38 cm), 0.20 inches (0.51 cm), 0.25 inches (0.064 cm), 0.30 inches (0.76 cm), 0.35 inches (0.90 cm), or 0.40 inches (1.02 cm).

The club head **100** further includes a first ratio of the length **392** to the height **388** of the sole transition profile **384**. In the illustrated embodiment, the first ratio of the sole transition profile **384** ranges from approximately 2.0-2.5. In other embodiments, the first ratio of the sole transition profile **384** may range from approximately 1.3-3.5. Further, in other embodiments, the first ratio of the sole transition profile **384** may be any value less than approximately 5.0, less than approximately 4.5, less than approximately 3.5, less than approximately 3.0, or less than approximately 2.5. For example, the first ratio of the sole transition profile **384** may be approximately 1.5, 2.0, 2.5, 3.0, 3.5, 4.0, 4.5, or 5.0.

ii. Transition Points and Radii of Curvature of the Sole Transition Profile

Referring to FIG. 9, the sole transition profile **384** further includes more than one radius of curvature and more than one transition point. The transition points indicate a change in the radius of curvature of the sole transition profile **384**. In the illustrated embodiment, the sole transition profile **384** includes a first sole transition point **412**, a second sole transition point **422**, a first sole radius of curvature **414**, and a second sole radius of curvature **424**. The first sole transition point **412** is offset from the loft plane **160** by a first offset distance **416**. The second sole transition point **222** is offset from the loft plane **160** by a second offset distance **426**. The second offset distance **426** is greater than the first offset distance **416**. The first sole radius of curvature **414** extends from the bottom edge **138** to the first sole transition point **412**. The second sole radius of curvature **424** extends from the first sole transition point **412** to the second sole transition point **422**.

Referring to FIG. 9, in the illustrated embodiment, the first offset distance **416** and the second offset distance **426** are substantially constant from the heel **116** to the toe **120** of the club head **100**. In other embodiments, the first offset distance **416** may vary from the heel **116** to the toe **120** of the club head **100**. For example, the first offset distance **416** may be greater toward the heel **116** of the club head **100**, toward the toe **116** of the club head **100**, in the center of the

club head **100**, or in any combination of the above described positions. The first offset distance **416** may vary from the heel **116** to the toe **120** according to any profile, such as, for example, linear, parabolic, quadratic, exponential, or any other profile.

Further, in other embodiments, the second offset distance **426** may vary from the heel **116** to the toe **120** of the club head **100**. For example, the second offset distance **426** may be greater toward the heel **116** of the club head **100**, toward the toe **120** of the club head **100**, in the center of the club head **100**, or in any combination of the above described positions. The second offset distance **426** may vary from the heel **116** to the toe **120** according to any profile, such as, for example, linear, parabolic, quadratic, exponential, or any other profile.

In the illustrated embodiment, the sole transition profile **384** has a first sole radius of curvature **414** of approximately 0.40 inches (1.02 cm). In other embodiments, the first sole radius of curvature **414** may range from approximately 0.30 to 0.50 inches (0.76 to 1.27 cm). For example, the first sole radius of curvature **414** may be approximately 0.30 inches (0.76 cm), 0.35 inches (0.89 cm), 0.40 inches (1.02 cm), 0.45 inches (1.14 cm), or 0.50 inches (1.27 cm). For further example, the first sole radius of curvature **414** can be less than approximately 0.5 inches (1.27 cm), less than approximately 0.475 inches (1.21 cm), less than approximately 0.45 inches (1.14 cm), less than approximately 0.425 inches (1.08 cm), or less than approximately 0.40 inches (1.02 cm).

Referring to FIG. 9, in the illustrated embodiment, the first sole radius of curvature **414** and the second sole radius of curvature **424** are substantially constant from the heel **116** to the toe **120** of the club head **100**. In other embodiments, the first sole radius of curvature **414** may vary from the heel **116** to the toe **120** of the club head **100**. For example, the first sole radius of curvature **414** may be greater toward the heel **116** of the club head **100**, toward the toe **120** of the club head **100**, in the center of the club head **100**, or in any combination of the above described positions. The first sole radius of curvature **414** may vary from the heel **116** to the toe **120** according to any profile, such as, for example, linear, parabolic, quadratic, exponential, or any other profile.

In other embodiments, the second sole radius of curvature **424** may vary from the heel **116** to the toe **120** of the club head **100**. For example, the second sole radius of curvature **424** may be greater toward the heel **116** of the club head **100**, toward the toe **120** of the club head **100**, in the center of the club head **100**, or in any combination of the above described positions. The second sole radius of curvature **424** may vary from the heel **116** to the toe **120** according to any profile, such as, for example, linear, parabolic, quadratic, exponential, or any other profile.

Referring to FIGS. 9 and 10, in the illustrated embodiment, the sole transition profile **384** has two transition points and two radii of curvature. In other embodiments, the sole transition profile **384** may include any number of transition points, and any number of radii of curvature. For example, the sole transition profile **384** may include one, two, three, four, five, six, seven, eight, nine, ten, or any other number of transition points. For further example, the sole transition profile **384** may include one, two, three, four, five, six, seven, eight, nine, ten, or any other number of radii of curvature.

The aerodynamic drag on a club head decreases as the first ratio of the sole transition profile approaches a value of 1.0 (i.e. as the length of the sole transition profile approaches the height of the sole transition profile, or as the height of the sole transition profile approaches the length of the sole

transition profile). The first ratio of the sole transition profile **384** of the club head **100** described herein is less than the first ratio of the sole transition profile of other known golf club heads. Therefore, the club head **100** described herein has less aerodynamic drag, and therefore increased swing speeds and ball distance than other known golf club heads.

The aerodynamic drag reduction due to the first sole radius of curvature **414** was determined using wind tunnel testing for various exemplary club heads having varied first sole radii of curvature. Referring to FIG. **11**, a first club head having a first sole radius of curvature of approximately 0.10 inches (0.25 cm), a second club head having a first sole radius of curvature of approximately 0.30 inches (0.76 cm), and a third club head having a first sole radius of curvature of approximately 0.50 inches (1.27 cm) were tested in a wind tunnel. The lowest aerodynamic drag for optimal closed face impacts, measured using the drag coefficient, was observed in the second club head having the first sole radius of curvature of approximately 0.30 inches (0.76 cm). Further, in other embodiments, the lowest aerodynamic drag can be observed with a first sole radius of curvature between 0.30 inches (0.76 cm) and 0.40 inches (1.02 cm).

FIG. **11** illustrates that increasing the first sole radius of curvature does not always result in reduced drag. For example, increasing the first sole radius of curvature may result in an increase or a decrease in drag. Similarly, decreasing the first sole radius of curvature does not always result in increased drag. For example, decreasing the first sole radius of curvature may result in an increase or a decrease in drag. In the illustrated example, when the first sole radius of curvature is increased from 0.10 inches (0.25 cm) to 0.30 inches (0.76 cm), the drag is reduced by a greater extent than when the first sole radius of curvature is increased from 0.10 inches (0.25 cm) to 0.50 inches (1.27 cm) for an optimal closed face club angle at impact (i.e. 90 degrees). Further, when the first sole radius of curvature is increased from 0.30 inches (0.76 cm) to 0.50 inches (1.27 cm), the drag on the club head **100** increases for an optimal closed face club angle at impact (i.e. 90 degrees). Accordingly, an optimum first sole radius of curvature exists to reduce aerodynamic drag on the club head **100** for both an optimal closed face at impact. FIG. **11** further illustrates a curve fit to the data indicating the first sole radius of curvature between approximately 0.30 inches (0.76 cm) and 0.40 inches (1.02 cm) results in the greatest drag reduction on the club head **100** for optimal closed face angles at impact.

iii. Angles of the Sole Transition Profile

Referring to FIG. **10**, the sole transition profile **384** can be further characterized by the position of the first and the second sole transition points **412**, **422** in relation to the lowest point of the sole **328** and the loft plane **160**. When viewed from a side cross sectional view, the sole transition profile **384** includes a first axis **450**, a second axis **460**, a first angle **452**, and a second angle **462**. The first axis **450** extends through the first sole transition point **412** and the second sole transition point **422**, and forms the first angle **452** with the loft plane **160**. The second axis **460** extends through the first sole transition point **412** and the lowest point of the sole **328**, and forms the second angle **462** with the loft plane **160**.

In the illustrated embodiment, the first angle **452** of the sole transition profile **384** ranges from approximately 95-105 degrees and the second angle **462** of the sole transition profile **384** ranges from 85-95 degrees. In other embodiments, the first angle **452** of the sole transition profile **384** may range from approximately 80-120 degrees, and the second angle **462** of the sole transition profile **384** may range

from 70-120 degrees. In other embodiments, the second angle **262** of the sole transition profile **384** may be any value greater than 70 degrees, greater than 75 degrees, greater than 80 degrees, or greater than 90 degrees.

III. Rear Transition Region

Referring to FIGS. **2**, **3**, and **12**, the rear transition region **544** extends between the crown **124** and the sole **132** of the club head **100**, from near the heel **116** to near the toe **120** along the skirt or trailing edge or back end **114** of the club head **100**. The rear transition region **544** includes a rear transition profile **584** when viewed from a cross sectional view. The cross sectional view can be taken at any point along the back end **114** of the club head **100** from near the heel **116** to near the toe **120**. In many embodiments, the side cross sectional view of the rear transition profile **584** is taken along a plane having a varied orientation relative to the loft plane **160** depending on position relative to the heel **116** or toe **120** of the club head **100**. In these or other embodiments, the cross sectional view is taken along a rear plane positioned perpendicular to the back end **114** of the club head. Specifically, in these or other embodiments, the rear plane is perpendicular to a tangent plane positioned adjacent to the back end **114** of the club head when viewed from a top view.

i. Transition Points and Radius of Curvature of the Rear Transition Profile

Referring to FIG. **12**, the rear transition profile **584** further includes a rear radius of curvature **614** positioned between a first transition point **612** and a second transition point **622**. In many embodiments, the first transition point **612** is located at an edge of the crown **124** near the back end **114** where the curvature of the crown **124** near the back end **114** deviates in the cross sectional view. In some embodiments, the position of the first transition point **612** can be determined using a spline method, which can indicate where the crown curvature of the club head **100** deviates to transition into the skirt or back end **114**. In other embodiments, the first transition point **612** can be located on the back end **114** or skirt of the club head **100** in the cross sectional view where the rear radius of curvature **614** starts. The second transition point is located on the back end **114** or skirt of the club head in the cross sectional view where the rear radius of curvature **614** ends.

In the illustrated embodiment, the rear transition profile **584** has a rear radius of curvature **614** of approximately 0.15 inches (0.38 cm). In other embodiments, the rear radius of curvature **614** may range from approximately 0.10 to 0.25 inches (0.25 to 0.64 cm). For further example, the rear radius of curvature **614** may be approximately 0.10 inches (0.25 cm), 0.15 inches (0.38 cm), 0.20 inches (0.51 cm), or 0.25 inches (0.64 cm). For further example, the rear radius of curvature **614** can be less than approximately 0.3 inches (0.76 cm), less than approximately 0.275 inches (0.70 cm), less than approximately 0.25 inches (0.64 cm), less than approximately 0.225 inches (0.57 cm), or less than approximately 0.20 inches (0.51 cm).

In the illustrated embodiment, the rear radius of curvature **614** is substantially constant from the heel **116** to the toe **120** along the skirt or back end **114** of the club head **100**. In other embodiments, the rear radius of curvature **614** may vary from the heel **116** to the toe **120** along the skirt or back end **114** of the club head **100**. The rear radius of curvature **614** may be greater near the heel **116** of the club head **100**, near the toe **120** of the club head **100**, in the center of the skirt or back end **114** of the club head **100**, or in any combination of the above described positions. For example, the rear radius of curvature **614** may be greater near the heel **116** and toe **120** of the than in the center of the back end **114** of the club

head. For further example, the rear radius of curvature **614** may be greater in the center of the back end **114** of the club head than near the heel **116** and toe **120**.

The rear radius of curvature **614** may vary from the heel **116** to the toe **120** according to any profile, such as, for example, linear, parabolic, quadratic, exponential, or any other profile. Further, the rear radius of curvature **614** can comprise only a portion of the rear transition region **544**, such as near the heel **116** of the club head **100**, near the toe **120** of the club head **100**, in the center of the back end **114** of the club head **100**, or in any combination of the above described positions.

In the illustrated embodiment, the rear transition profile **584** has one radius of curvature. In other embodiments, the rear transition profile **584** may include any number of any number of radii of curvature. For example, the rear transition profile **584** may include one, two, three, four, five, six, seven, eight, nine, ten, or any other number of radii of curvature.

The aerodynamic drag reduction due to the first rear radius of curvature **614** was determined using wind tunnel testing for various exemplary club heads having varied first rear radii of curvature. Referring to FIG. **13**, a first club head **410** having a first rear radius of curvature of approximately 0.15 inches (0.38 cm), a second club head **420** having a first rear radius of curvature of approximately 0.25 inches (0.64 cm), a third club head **430** having a first rear radius of curvature of approximately 0.35 inches (0.90 cm), and a fourth club head **440** having a first rear radius of curvature of approximately 0.45 inches (1.14 cm), were tested in a wind tunnel. The lowest aerodynamic drag, measured using the drag coefficient, was observed in the first club head having the first rear radius of curvature of approximately 0.15 inches (0.38 cm). FIG. **13** illustrates that reducing the first rear radius of curvature results in reduced drag on the club head.

ii. Height of the Rear Transition Profile

Further referring to FIG. **12**, in the illustrated embodiment, the rear transition profile **584** includes a height **588** measured as the distance from the first transition point **612** to the second transition point **622** in a direction parallel to the loft plane **160**. In the illustrated embodiment, the height **588** of the rear transition profile **584** ranges from approximately 0.10-0.26 inches (0.25-0.66 cm). In other embodiments, the height **588** of the rear transition profile **584** may range from 0.05-0.50 inches (0.13-1.27 cm). For example, the height **588** of the rear transition profile **584** may be approximately 0.05 inches (0.13 cm), 0.10 inches (0.25 cm), 0.15 inches (0.38 cm), 0.20 inches (0.51 cm), 0.25 inches (0.64 cm), 0.30 inches (0.76 cm), 0.35 inches (0.89 cm), 0.40 inches (1.02 cm), 0.45 inches (1.14 cm), or 0.50 inches (1.27 cm).

IV. Relation of Crown, Sole, and Rear Transition Profiles

In many embodiments, the greatest reduction in aerodynamic drag resulting from the transition regions can be achieved when the club head **100** includes the crown transition profile **184** with the first crown radius of curvature **214**, the sole transition profile **384** with the first sole radius of curvature **414**, and the rear transition profile **584** with the rear radius of curvature **614**, as described above. The illustrated embodiment of the club head **100** includes the crown transition profile **184**, the sole transition profile **384**, and the rear transition profile **584** to maximize aerodynamic drag reduction resulting from the crown, sole, and rear transition regions on the club head **100**. In many embodiments, the crown transition profile contributes the greatest percentage to overall drag reduction on the club head **100** having the

crown transition profile **184**, the sole transition profile **384**, and the rear transition profile **584**.

The club head **100** described herein further includes various optimized relationships of the crown transition profile **184** with the first crown radius of curvature **214**, the sole transition profile **384** with the first sole radius of curvature **414**, and the rear transition profile **584** with the rear radius of curvature **614**, to reduce aerodynamic drag on the club head **1000**. In many embodiments, the first sole radius of curvature **414** is greater than the first crown radius of curvature **214**, and the first crown radius of curvature **214** is greater than the rear radius of curvature **614** to reduce aerodynamic drag on the club head **100**.

In the illustrated embodiment, a first ratio of the first crown radius of curvature **214** to the first sole radius of curvature **414** is approximately 0.24 inches (0.61 cm). In other embodiments, the first ratio of the first crown radius of curvature **214** to the first sole radius of curvature **414** can range from approximately 0.4-1.0, from approximately 0.5-1.0, from approximately 0.6-1.0, from approximately 0.7-1.0, from approximately 0.8-1.0, or from approximately 0.9-1.0.

In the illustrated embodiment, a second ratio of the first crown radius of curvature **214** to the rear radius of curvature **614** is approximately 1.33 inches (3.38 cm). In other embodiments, the second ratio of the first crown radius of curvature **214** to the rear radius of curvature **614** can range from approximately 1.0-3.5, from approximately 1.0-3.0, from approximately 1.0-2.5, from approximately 1.0-2.0, or from approximately 1.0-1.5.

In the illustrated embodiment, a third ratio of the first sole radius of curvature **414** to the rear radius of curvature **614** is approximately 1.5 inches (3.81 cm). In other embodiments, the third ratio of the first sole radius of curvature **414** to the rear radius of curvature **614** can range from approximately 1.0-5.0, from approximately 1.0-4.5, from approximately 1.0-4.0, from approximately 1.0-3.5, from approximately 1.0-3.0, or from approximately 1.0-2.5.

In other embodiments, the club head can have any number of crown radii of curvature, such as one, two, three, four, or five crown radii of curvature. Further, in other embodiments, the club head can have any number of sole radii of curvature, such as one, two, three, four, or five sole radii of curvature. Further, in other embodiments, the club head can have any number of rear radii of curvature, such as one, two, three, four, or five rear radii of curvature.

The club head **100** described herein includes the crown transition profile, the sole transition profile, and the rear transition profile. In other embodiments, the club head can include one or more of the crown transition profile, the sole transition profile, or the rear transition profile, as described herein. For example, in other embodiments, the club head can have one or more of: a crown transition region having a crown transition profile with one or more crown radii of curvature, a sole transition region having a sole transition profile with one or more sole radii of curvature, or a rear transition region having a rear transition profile with one or more rear radii of curvature. While the maximum aerodynamic drag reduction due to the transition regions results when the club head includes all of the crown transition profile, the sole transition profile, and the rear transition profile, aerodynamic drag can still be reduced in embodiments where the club head includes fewer than the crown transition profile, the sole transition profile, and the rear transition profile, compared to a club head devoid of the crown transition profile, the rear transition profile, and the sole transition profile.

V. Method of Manufacturing

FIG. 14 illustrates a method 1000 of manufacturing the club head 100 described herein. Block 1100 of method 1000 includes forming a strike face 108. In many embodiments, forming the strike face 108 is accomplished by machining. In other embodiments, forming the strike face 108 can be accomplished by machining, casting, forging, layer by layer printing (e.g. 3D printing), or any other suitable process.

Further referring to FIG. 14, block 1200 of method 1000 includes forming a body 104 having a front end 112, a back end 114 opposite the front end 112, a heel 116, a toe 120 opposite the heel 116, a crown 124 having an apex 128, and a sole 132 opposite the crown 124, and at least one of a crown transition region, a sole transition region or a rear transition region. In many embodiments, forming the body 104 is accomplished by casting. In other embodiments, forming the body 104 can be accomplished by machining, casting, forging, layer by layer printing (e.g. 3D printing), or any other suitable process.

Further referring to FIG. 14, block 1300 of method 1000 includes coupling the strike face 108 to the body 104 resulting in the club head 100 having at least one of the crown transition region, the sole transition region, or the rear transition region, as described herein. In many embodiments, coupling the strike face 108 to the body 104 can be accomplished by welding. In other embodiments, coupling the strike face 108 to the body 104 can be accomplished by any other suitable method.

The blocks of the method 1000 of manufacturing the club head 100 can be combined into a single block or performed simultaneously. For example, the strike face 108 and the body 104 may be formed together. Further, the method 1000 of manufacturing the club head 100 can include additional or different blocks. Other variations can be implemented for method 1000 without departing from the scope of the present disclosure.

Clause 1: A golf club head comprising a strike face having a top edge, a bottom edge, and a geometric center, the strike face defining a loft plane positioned tangent to the strike face extending through the geometric center; and a body including a front end, a back end opposite the front end, a heel, a toe opposite the heel, a crown including and apex and a crown transition profile, the crown transition profile having a first crown radius of curvature extending from the top edge of the strike face to a first crown transition point, wherein the first crown radius of curvature is between approximately 0.18 inches and 0.30 inches, a sole including a lowest point and a sole transition profile, the sole transition profile having a first sole radius of curvature extending from the bottom edge of the strike face to a first sole transition point, wherein the first sole radius of curvature is between approximately 0.3 inches (0.76 cm) and 0.5 inches (1.27 cm), and a rear transition profile having a rear radius of curvature between approximately 0.10 inches (0.25 cm) and 0.25 inches (0.64 cm).

Clause 2: The golf club head of clause 1, wherein the crown transition profile further comprises a length measured as the perpendicular distance from the loft plane to an apex plane, and a height measured as the distance from the top edge of the strike face to a crown axis in a direction parallel to the loft plane, wherein a ratio of the length to the height of the crown transition profile is less than or equal to 3.5.

Clause 3: The golf club head of clause 2, wherein the ratio of the length to the height of the crown transition profile is less than or equal to 3.0.

Clause 4: The golf club head of clause 2, wherein the length of the crown transition profile is between 1.13-1.34

inches (2.87-3.40 cm), and the height of the crown transition profile is between 0.41-0.47 inches (1.04-1.19 cm).

Clause 5: The golf club head of clause 1, wherein the apex is offset from the loft plane by an apex distance measured in a direction perpendicular to the loft plane, the apex distance between approximately 0.8-1.4 inches (2.03-3.56 cm).

Clause 6: The golf club head of clause 1, wherein the crown transition profile further comprises a second crown radius of curvature extending from the first crown transition point to a second crown transition point, wherein the second crown radius of curvature is greater than the first crown radius of curvature.

Clause 7: The golf club head of clause 1, further comprising a heel to toe radius of curvature extending along the top edge of the strike face from near the heel to near the toe of the club head, wherein the heel to toe radius of curvature is greater than approximately 4.9 inches (12.4 cm).

Clause 8: The golf club head of clause 1, wherein the sole transition profile further comprises a length measured as the perpendicular distance from the loft plane to a sole plane, and a height measured as the distance from the bottom edge of the strike face to a sole axis in a direction parallel to the loft plane, wherein a ratio of the length to the height of the sole transition profile is less than or equal to 3.5.

Clause 9: The golf club head of clause 8, wherein the length of the sole transition profile is between 0.10-1.25 inches (0.25-3.18 cm) and the height of the sole transition profile is between 0.05-0.40 inches (0.13-1.02 cm).

Clause 10: The golf club head of clause 1, wherein the sole transition profile further comprises a second sole radius of curvature extending from the first sole transition point to a second sole transition point, wherein the second sole radius of curvature is greater than the first sole radius of curvature.

Clause 11: A golf club comprising a shaft, a grip, and a golf club head including a strike face having a top edge, a bottom edge, and a geometric center, the strike face defining a loft plane positioned tangent to the strike face extending through the geometric center, a body including, a front end, a back end opposite the front end, a heel, a toe opposite the heel, a crown including and apex and a crown transition profile, the crown transition profile having a first crown radius of curvature extending from the top edge of the strike face to a first crown transition point, wherein the first crown radius of curvature is between approximately 0.18 inches (0.46 cm) and 0.30 inches (0.76 cm), a sole including a lowest point and a sole transition profile, the sole transition profile having a first sole radius of curvature extending from the bottom edge of the strike face to a first sole transition point, wherein the first sole radius of curvature is between approximately 0.3 inches (0.46 cm) and 0.5 inches (1.27 cm), and a rear transition profile having a rear radius of curvature between approximately 0.10 inches (0.254 cm) and 0.25 inches (0.64 cm).

Clause 12: The golf club of clause 11, wherein the crown transition profile further comprises a length measured as the perpendicular distance from the loft plane to an apex plane, and a height measured as the distance from the top edge of the strike face to a crown axis in a direction parallel to the loft plane, wherein a ratio of the length to the height of the crown transition profile is less than or equal to 3.5.

Clause 13: The golf club of clause 12, wherein the ratio of the length to the height of the crown transition profile is less than or equal to 3.0.

Clause 14: The golf club head of clause 12, wherein the length of the crown transition profile is between 1.13-1.34 inches (2.87-3.40 cm), and the height of the crown transition profile is between 0.41-0.47 inches (1.04-1.19 cm).

Clause 15: The golf club of clause 11, wherein the crown transition profile further comprises a second crown radius of curvature extending from the first crown transition point to a second crown transition point, wherein the second crown radius of curvature is greater than the first crown radius of curvature.

Clause 16: The golf club of clause 11, further comprising a heel to toe radius of curvature extending along the top edge of the strike face from near the heel to near the toe of the club head, wherein the heel to toe radius of curvature is greater than approximately 4.9 inches (12.4 cm).

Clause 17: The golf club of clause 11, wherein the sole transition profile further comprises a length measured as the perpendicular distance from the loft plane to a sole plane, and a height measured as the distance from the bottom edge of the strike face to a sole axis in a direction parallel to the loft plane, wherein a ratio of the length to the height of the sole transition profile is less than or equal to 3.5.

Clause 18: The golf club of clause 17, wherein the length of the sole transition profile is between 0.10-1.25 inches (0.25-3.18 cm) and the height of the sole transition profile is between 0.05-0.40 inches (0.13-1.02 cm).

Clause 19: The golf club of clause 11, wherein the sole transition profile further comprises a second sole radius of curvature extending from the first sole transition point to a second sole transition point, wherein the second sole radius of curvature is greater than the first sole radius of curvature.

Clause 20: A method of manufacturing the golf club head of clause 1, comprising machining a strike face, casting a body having a front end, a back end opposite the front end, a heel, a toe opposite the heel, a crown having an apex and a crown transition profile, and a sole opposite the crown, coupling the strike face to the body by welding, resulting in the club head having the crown transition profile, the sole transition profile, and the rear transition profile.

Replacement of one or more claimed elements constitutes reconstruction and not repair. Additionally, benefits, other advantages, and solutions to problems have been described with regard to specific embodiments. The benefits, advantages, solutions to problems, and any element or elements that may cause any benefit, advantage, or solution to occur or become more pronounced, however, are not to be construed as critical, required, or essential features or elements of any or all of the claims.

As the rules to golf may change from time to time (e.g., new regulations may be adopted or old rules may be eliminated or modified by golf standard organizations and/or governing bodies such as the United States Golf Association (USGA), the Royal and Ancient Golf Club of St. Andrews (R&A), etc.), golf equipment related to the apparatus, methods, and articles of manufacture described herein may be conforming or non-conforming to the rules of golf at any particular time. Accordingly, golf equipment related to the apparatus, methods, and articles of manufacture described herein may be advertised, offered for sale, and/or sold as conforming or non-conforming golf equipment. The apparatus, methods, and articles of manufacture described herein are not limited in this regard.

While the above examples may be described in connection with a driver-type golf club, the apparatus, methods, and articles of manufacture described herein may be applicable to other types of golf club such as a fairway wood-type golf club, a hybrid-type golf club, an iron-type golf club, a wedge-type golf club, or a putter-type golf club. Alternatively, the apparatus, methods, and articles of manufacture

described herein may be applicable other type of sports equipment such as a hockey stick, a tennis racket, a fishing pole, a ski pole, etc.

Moreover, embodiments and limitations disclosed herein are not dedicated to the public under the doctrine of dedication if the embodiments and/or limitations: (1) are not expressly claimed in the claims; and (2) are or are potentially equivalents of express elements and/or limitations in the claims under the doctrine of equivalents.

Various features and advantages of the disclosure are set forth in the following claims.

The invention claimed is:

1. A golf club head comprising:

a strike face having a top edge, a bottom edge, and a geometric center, the strike face defining a loft plane positioned tangent to the strike face extending through the geometric center; and

a body including:

a front end, a back end opposite the front end;

a heel, a toe opposite the heel;

a crown including an apex and a crown transition profile, the crown transition profile having a first crown radius of curvature extending from the top edge of the strike face to a first crown transition point, wherein the first crown radius of curvature is between approximately 0.18 inches and 0.30 inches; a second crown radius of curvature extending from the first crown transition point to a second crown transition point, wherein the first and second transition points indicate a change in the radius of curvature of the crown transition profile;

a sole including a lowest point and a sole transition profile, the sole transition profile having a first sole radius of curvature extending from the bottom edge of the strike face to a first sole transition point, wherein the first sole radius of curvature is between approximately 0.3 inches and 0.5 inches; and

a crown transition region positioned between the strike face and the crown, the crown transition region including a heel to toe radius of curvature extending along the top edge of the strike face from near the heel to near the toe of the club head, wherein the heel to toe radius of curvature is greater than approximately 4.9 inches; and

a rear transition profile positioned between a first transition point, and a second transition point, the rear transition profile having a rear radius of curvature between approximately 0.10 inches and 0.25 inches.

2. The golf club head of claim 1, wherein the crown transition profile further comprises:

a length measured as the perpendicular distance from the loft plane to an apex plane; and

a height measured as the distance from the top edge of the strike face to a crown axis in a direction parallel to the loft plane;

wherein a ratio of the length to the height of the crown transition profile is less than or equal to 3.5.

3. The golf club head of claim 2, wherein the ratio of the length to the height of the crown transition profile is less than or equal to 3.0.

4. The golf club head of claim 2, wherein:

the length of the crown transition profile is between 1.13-1.34 inches; and

the height of the crown transition profile is between 0.41-0.47 inches.

21

5. The golf club head of claim 1, wherein the apex is offset from the loft plane by an apex distance measured in a direction perpendicular to the loft plane, the apex distance between approximately 0.8-1.4 inches.

6. The golf club head of claim 1, wherein the second crown radius of curvature is greater than the first crown radius of curvature.

7. The golf club head of claim 1, wherein the sole transition profile further comprises:

a length measured as the perpendicular distance from the loft plane to a sole plane; and

a height measured as the distance from the bottom edge of the strike face to a sole axis in a direction parallel to the loft plane;

wherein a ratio of the length to the height of the sole transition profile is less than or equal to 3.5.

8. The golf club head of claim 7, wherein:

the length of the sole transition profile is between 0.10-1.25 inches; and

the height of the sole transition profile is between 0.05-0.40 inches.

9. The golf club head of claim 1, wherein the sole transition profile further comprises a second sole radius of curvature extending from the first sole transition point to a second sole transition point, wherein the second sole radius of curvature is greater than the first sole radius of curvature.

10. A golf club head comprising:

a strike face having a top edge, a bottom edge, and a geometric center, the strike face defining a loft plane positioned tangent to the strike face extending through the geometric center; and

a body including:

a front end, a back end opposite the front end;

a heel, a toe opposite the heel; and

a crown including an apex and a crown transition profile, the crown transition profile having a first crown radius of curvature extending from the top edge of the strike face to a first crown transition point, wherein the first crown radius of curvature is between approximately 0.18 inches and 0.30 inches; a second crown radius of curvature extending from the first crown transition point to a second crown transition point, wherein the first and second transition points indicate a change in the radius of curvature of the crown transition profile; and

a crown transition region positioned between the strike face and the crown, the crown transition region including a heel to toe radius of curvature extending along the top edge of the strike face from near the heel to near the toe of the club head, wherein the heel to toe radius of curvature is greater than approximately 4.9 inches; and

a rear transition profile positioned between a first transition point, and a second transition point, the rear transition profile having a rear radius of curvature between approximately 0.10 inches and 0.25 inches.

11. The golf club of claim 10, wherein the crown transition profile further comprises:

a length measured as the perpendicular distance from the loft plane to an apex plane; and

a height measured as the distance from the top edge of the strike face to a crown axis in a direction parallel to the loft plane;

wherein a ratio of the length to the height of the crown transition profile is less than or equal to 3.5.

22

12. The golf club of claim 11, wherein the ratio of the length to the height of the crown transition profile is less than or equal to 3.0.

13. The golf club head of claim 11, wherein:

the length of the crown transition profile is between 1.13-1.34 inches; and

the height of the crown transition profile is between 0.41-0.47 inches.

14. The golf club of claim 10, wherein the second crown radius of curvature is greater than the first crown radius of curvature.

15. A method of manufacturing a golf club head comprising: machining a strike face having a top edge, a bottom edge, and a geometric center, the strike face defining a loft plane positioned tangent to the strike face extending through the geometric center;

casting a body having a front end, a back end opposite the front end, a heel, a toe opposite the heel, a crown and a sole opposite the crown; wherein

the crown comprises an apex and a crown transition profile, the crown transition profile having a first crown radius of curvature extending from the top edge of the strike face to a first crown transition point, wherein the first crown radius of curvature is between approximately 0.18 inches and 0.30 inches; a second crown radius of curvature extending from the first crown transition point to a second crown transition point, wherein the first and second transition points indicate a change in the radius of curvature of the crown transition profile;

the sole comprises a lowest point and a sole transition profile, the sole transition profile having a first sole radius of curvature extending from the bottom edge of the strike face to a first sole transition point, wherein the first sole radius of curvature is between approximately 0.3 inches and 0.5 inches;

a crown transition region positioned between the strike face and the crown, the crown transition region including a heel to toe radius of curvature extending along the top edge of the strike face from near the heel to near the toe of the club head, wherein the heel to toe radius of curvature is greater than approximately 4.9 inches;

a rear transition profile positioned between a first transition point, and a second transition point, the rear transition profile having a rear radius of curvature between approximately 0.10 inches and 0.25 inches; and

coupling the strike face to the body by welding, resulting in the club head having the crown transition profile and the sole transition profile.

16. The method of claim 15, wherein the crown transition profile further comprises:

a length measured as the perpendicular distance from the loft plane to an apex plane; and

a height measured as the distance from the top edge of the strike face to a crown axis in a direction parallel to the loft plane;

wherein a ratio of the length to the height of the crown transition profile is less than or equal to 3.5.

17. The method of claim 16, wherein the ratio of the length to the height of the crown transition profile is less than or equal to 3.0.

18. The method of claim 16, wherein:

the length of the crown transition profile is between 1.13-1.34 inches; and

the height of the crown transition profile is between
0.41-0.47 inches.

* * * * *