



(12) **United States Patent**  
**Kim et al.**

(10) **Patent No.:** **US 12,043,943 B2**  
(45) **Date of Patent:** **Jul. 23, 2024**

(54) **LAUNDRY MACHINE**

(71) Applicant: **LG ELECTRONICS INC.**, Seoul (KR)

(72) Inventors: **Sungryong Kim**, Seoul (KR);  
**Dongwon Kim**, Seoul (KR);  
**Kyeonghwan Kim**, Seoul (KR);  
**Heakyung Yoo**, Seoul (KR); **Youngmin Kim**, Seoul (KR)

(73) Assignee: **LG ELECTRONICS INC.**, Seoul (KR)

(\* ) Notice: Subject to any disclaimer, the term of this patent is extended or adjusted under 35 U.S.C. 154(b) by 0 days.

(21) Appl. No.: **17/683,037**

(22) Filed: **Feb. 28, 2022**

(65) **Prior Publication Data**

US 2022/0186422 A1 Jun. 16, 2022

**Related U.S. Application Data**

(60) Continuation of application No. 16/217,683, filed on Dec. 12, 2018, now Pat. No. 11,293,132, which is a (Continued)

(30) **Foreign Application Priority Data**

Apr. 30, 2010 (KR) ..... 10-2010-0040526  
Apr. 30, 2010 (KR) ..... 10-2010-0040527  
(Continued)

(51) **Int. Cl.**

**D06F 39/08** (2006.01)  
**D06F 29/00** (2006.01)

(Continued)

(52) **U.S. Cl.**

CPC ..... **D06F 39/08** (2013.01); **D06F 29/00** (2013.01); **D06F 29/02** (2013.01); **D06F 39/12** (2013.01);

(Continued)

(58) **Field of Classification Search**

CPC ..... D06F 39/08; D06F 29/00; D06F 29/02; D06F 39/12; D06F 37/42; D06F 39/085; D06F 39/10

(Continued)

(56) **References Cited**

**U.S. PATENT DOCUMENTS**

3,304,751 A \* 2/1967 Schwing ..... D06F 39/088 68/148  
4,030,788 A 6/1977 Bleeker ..... 312/333  
(Continued)

**FOREIGN PATENT DOCUMENTS**

CN 2260097 Y 8/1997  
CN 1349012 A 5/2002  
(Continued)

*Primary Examiner* — David G Cormier

*Assistant Examiner* — Thomas Bucci

(74) *Attorney, Agent, or Firm* — Bryan Cave Leighton Paisner LLP

(57) **ABSTRACT**

A laundry apparatus including a cabinet; a first space provided in the cabinet, in which a first treating part provided to treat laundry is installed; a second space provided in the cabinet, in which a second treating part provided to treat laundry is installed; a drawer movably provided in the second space, in which the second treating part is installed; and a rail unit configured to limit vertical and horizontal movement of the drawer with respect to the second space and to guide the outward movement of the drawer. Therefore, laundry may be treated by using the first and second treating parts and vibration and noise generated in the second treating part may be reduced.

**7 Claims, 34 Drawing Sheets**

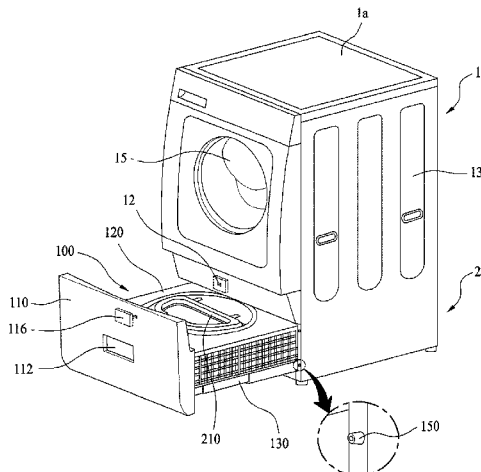

**Related U.S. Application Data**

division of application No. 15/251,970, filed on Aug. 30, 2016, now Pat. No. 10,179,964, which is a division of application No. 13/097,934, filed on Apr. 29, 2011, now Pat. No. 10,081,898.

2007/0249212 A1 10/2007 Buecker et al.  
 2008/0265729 A1 10/2008 Netzer et al.  
 2008/0289368 A1 11/2008 Braz et al.  
 2009/0007602 A1 1/2009 Woo ..... D06F 39/10  
 68/208

(30) **Foreign Application Priority Data**

Apr. 30, 2010 (KR) ..... 10-2010-0040624  
 Apr. 30, 2010 (KR) ..... 10-2010-0040625  
 May 4, 2010 (KR) ..... 10-2010-0042004  
 May 28, 2010 (KR) ..... 10-2010-0050125

2009/0013730 A1 1/2009 Woo et al.  
 2009/0031761 A1 2/2009 Kim et al.  
 2009/0031762 A1 2/2009 Kim et al.  
 2009/0113945 A1 5/2009 Kim ..... D06F 17/04  
 68/5 C

(51) **Int. Cl.**

**D06F 29/02** (2006.01)  
**D06F 39/12** (2006.01)  
**D06F 37/42** (2006.01)  
**D06F 39/10** (2006.01)

2009/0126415 A1 5/2009 Lyu et al.  
 2009/0139273 A1 6/2009 Kim et al. .... 68/23.1  
 2009/0139276 A1 6/2009 Kim ..... D06F 23/02  
 68/17 R

(52) **U.S. Cl.**

CPC ..... *D06F 37/42* (2013.01); *D06F 39/085*  
 (2013.01); *D06F 39/10* (2013.01)

2009/0145174 A1 6/2009 Kim ..... D06F 23/02  
 68/27  
 2009/0145175 A1 6/2009 Kim ..... D06F 29/005  
 68/27

(58) **Field of Classification Search**

USPC ..... 68/196  
 See application file for complete search history.

2009/0145176 A1 6/2009 Kim et al. .... 68/27  
 2009/0145177 A1 6/2009 Kim et al.  
 2009/0145476 A1 6/2009 Fetzer et al.  
 2009/0146536 A1 6/2009 Kim et al.  
 2009/0158784 A1 6/2009 Kim ..... D06F 31/00  
 68/27

(56) **References Cited**

U.S. PATENT DOCUMENTS

4,329,859 A 5/1982 Roberts et al.  
 5,031,426 A \* 7/1991 Wilson ..... D06F 39/083  
 239/593  
 5,117,659 A 6/1992 Sharp et al.  
 5,470,142 A 11/1995 Sargeant ..... A47L 15/0084  
 312/258  
 5,606,879 A 3/1997 Froelicher et al.  
 5,660,063 A 8/1997 Lee ..... D06F 39/10  
 210/167.01  
 6,167,733 B1 1/2001 Lee ..... D06F 39/085  
 68/18 F  
 6,286,344 B1 9/2001 Jeon et al.  
 6,397,643 B1 6/2002 Chang et al.  
 6,474,113 B1 11/2002 Park et al.  
 6,618,887 B2 9/2003 Kim et al.  
 6,857,295 B2 2/2005 Hansen et al.  
 6,978,556 B1 12/2005 Cornelious  
 7,032,271 B2 4/2006 Lin  
 7,472,712 B2 1/2009 Ashton ..... A47L 15/0084  
 134/104.1  
 8,028,548 B2 10/2011 Woo ..... D06F 39/10  
 68/12.13  
 9,133,576 B2 9/2015 Lee et al.  
 2001/0010165 A1 8/2001 Kubota et al. .... 68/12.12  
 2002/0042957 A1 \* 4/2002 Kim ..... D06F 23/04  
 68/12.02  
 2002/0056293 A1 5/2002 Kin et al.  
 2003/0042654 A1 \* 3/2003 Bienick ..... D06F 37/28  
 264/239  
 2004/0083770 A1 5/2004 Lyu  
 2004/0148974 A1 8/2004 No ..... D06F 39/10  
 68/12.13  
 2004/0163690 A1 8/2004 Kim ..... 134/104.1  
 2005/0120758 A1 6/2005 Thies ..... D06F 39/10  
 68/18 R  
 2005/0217072 A1 10/2005 Lin  
 2005/0229643 A1 10/2005 Kim  
 2005/0279141 A1 12/2005 Kim  
 2006/0000240 A1 1/2006 Song  
 2006/0086380 A1 4/2006 Choi et al.  
 2007/0240457 A1 10/2007 Jang ..... D06F 39/083  
 68/18 F  
 2007/0246089 A1 10/2007 Welch ..... A47L 15/0084  
 134/56 D

2009/0199601 A1 8/2009 Kim ..... D06F 39/083  
 68/208  
 2009/0288452 A1 11/2009 Lee et al.  
 2010/0000266 A1 \* 1/2010 Chung ..... D06F 39/083  
 68/205 R  
 2010/0011609 A1 1/2010 Park et al.  
 2010/0064736 A1 3/2010 Jeong ..... D06F 29/00  
 68/13 R  
 2010/0088828 A1 4/2010 Kim ..... D06F 39/022  
 8/159  
 2010/0088829 A1 4/2010 Park et al. .... 8/159  
 2010/0101282 A1 \* 4/2010 Jeong ..... D06F 37/145  
 68/139  
 2010/0107704 A1 5/2010 Seo et al.  
 2010/0115709 A1 5/2010 Kim ..... D06F 39/022  
 8/159  
 2010/0269266 A1 10/2010 Lee et al.  
 2010/0275381 A1 11/2010 Ko et al.  
 2010/0275386 A1 11/2010 Ko et al.  
 2010/0287712 A1 11/2010 Pyo et al.  
 2010/0307200 A1 \* 12/2010 Jeong ..... D06F 29/00  
 68/13 R  
 2011/0016738 A1 1/2011 Ashrafzadeh et al. .... 34/108  
 2011/0016927 A1 1/2011 Kim et al.  
 2011/0023555 A1 2/2011 Murrell et al.  
 2011/0100071 A1 5/2011 Mazzon ..... D06F 39/10  
 68/208  
 2012/0138107 A1 6/2012 Fountain ..... A47L 15/0084  
 134/111  
 2013/0186437 A1 7/2013 Tuller ..... A47L 15/4251  
 134/99.1

FOREIGN PATENT DOCUMENTS

CN 2775090 Y 4/2006  
 CN 101451294 A 6/2009  
 DE 10-2008-058267 A1 6/2009  
 DE 102008058269 A1 7/2009  
 EP 0668389 A1 8/1995  
 EP 2 063 012 A1 5/2009  
 EP 2 063 013 A1 5/2009  
 JP 10-211393 A 8/1998  
 JP 2000-334192 A 12/2000  
 JP 3443364 B 9/2003  
 JP 2004-089339 A 3/2004  
 JP 2007-120875 A 5/2007  
 KR 20-0136087 Y1 7/1995  
 KR 20-1998-0060623 U 11/1998  
 KR 10-0151205 B1 12/1998  
 KR 10-1999-0056859 A 7/1999  
 KR 10-2001-0088210 A 9/2001  
 KR 10-2003-0031343 A 4/2003  
 KR 10-0381163 B1 4/2003

(56)

**References Cited**

FOREIGN PATENT DOCUMENTS

KR	10-2003-0055973	A	7/2003
KR	10-2004-0046973	A	5/2004
KR	10-2006-0063394	A	6/2006
KR	10-2007-0034818	A	3/2007
KR	10-2007-0105054	A	10/2007
KR	10-2007-0113432	A	11/2007
KR	10-2008-0052964	A	6/2008
KR	10-2008-0065762	A	7/2008
KR	10-2008-0101380	A	11/2008
KR	10-2008-0109488	A	12/2008
KR	10-2009-0054787	A	1/2009
KR	10-2009-0027111	A	3/2009
KR	10-2009-0052457	A	5/2009
KR	10-2009-0057791	A	6/2009
KR	10-2009-0057792	A	6/2009
KR	10-2009-0078983	A	7/2009
KR	10-2010-0048343	A	5/2010
WO	2009/065198	A1	5/2009

\* cited by examiner

FIG. 1

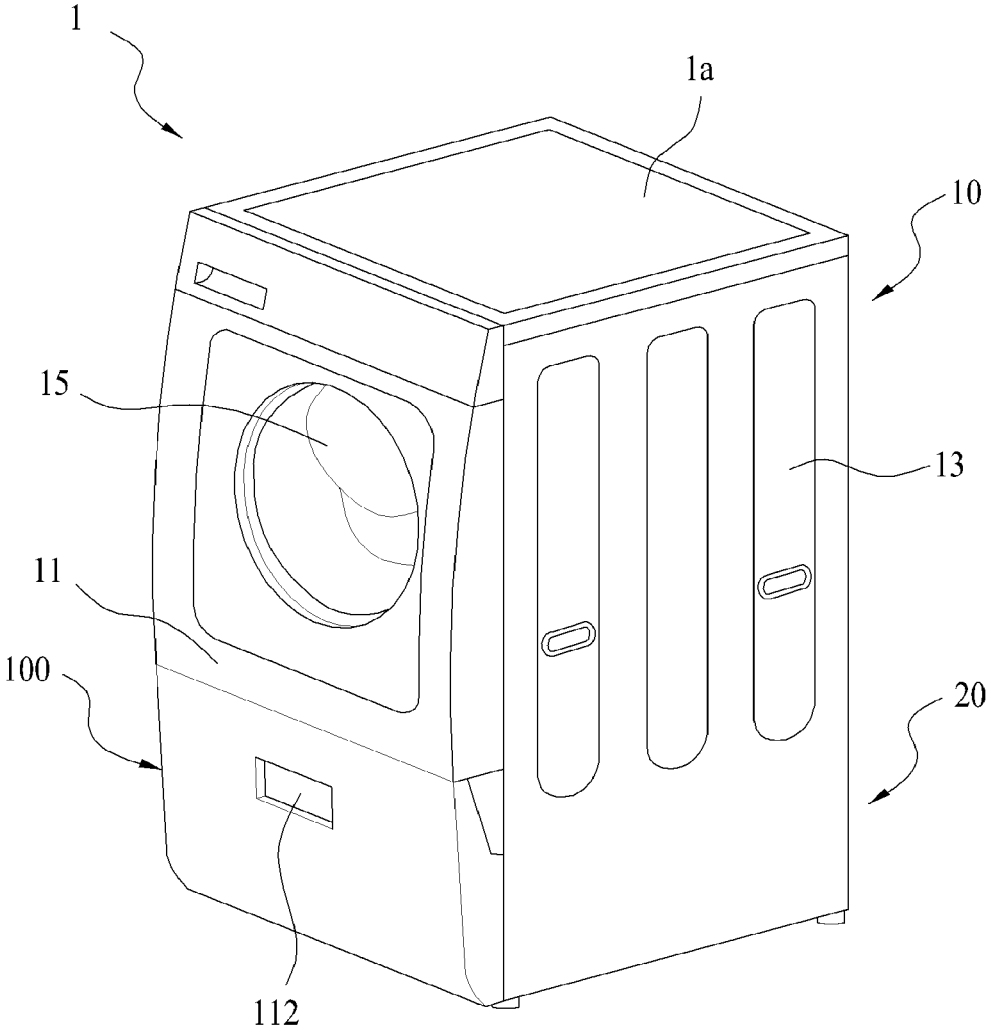

FIG. 2

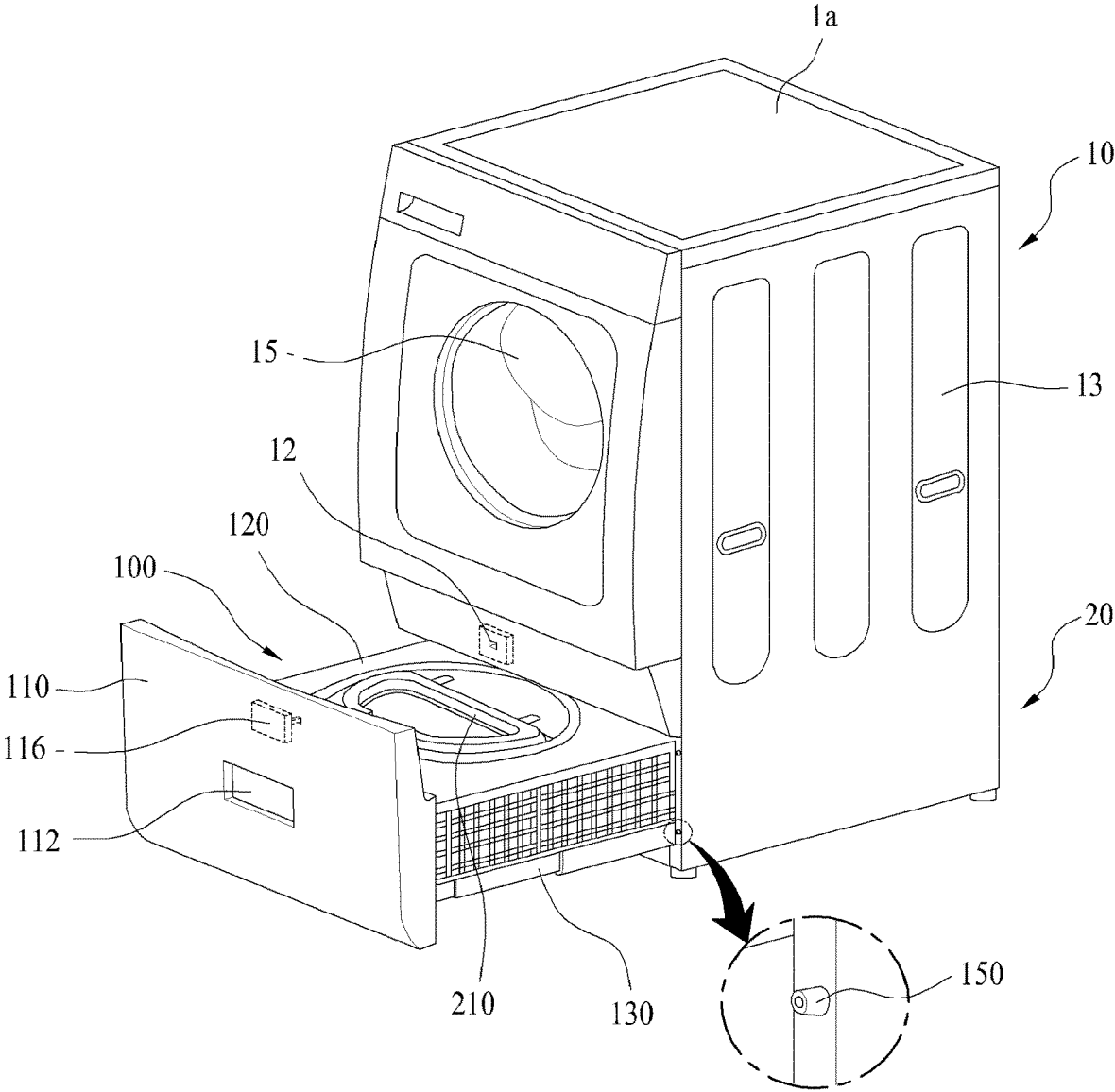

FIG. 3

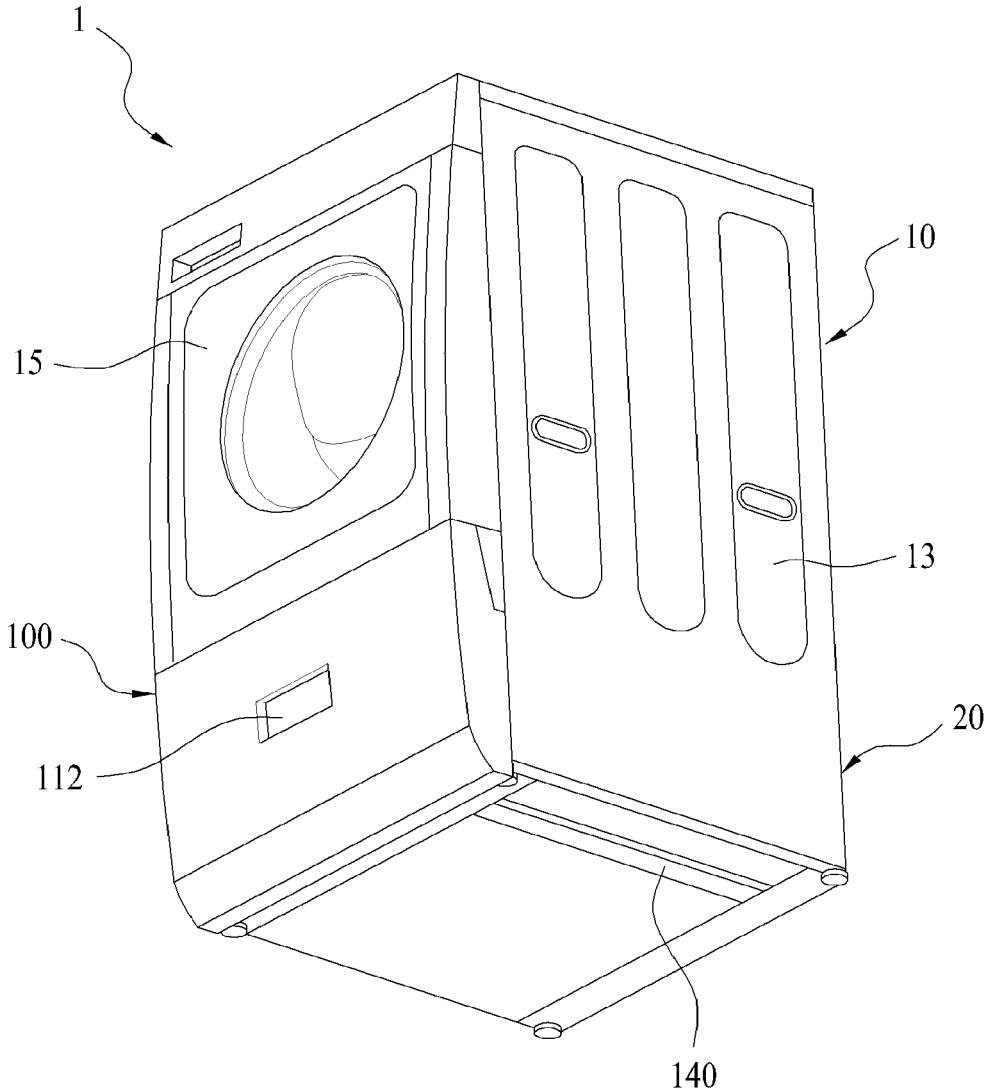

FIG. 4

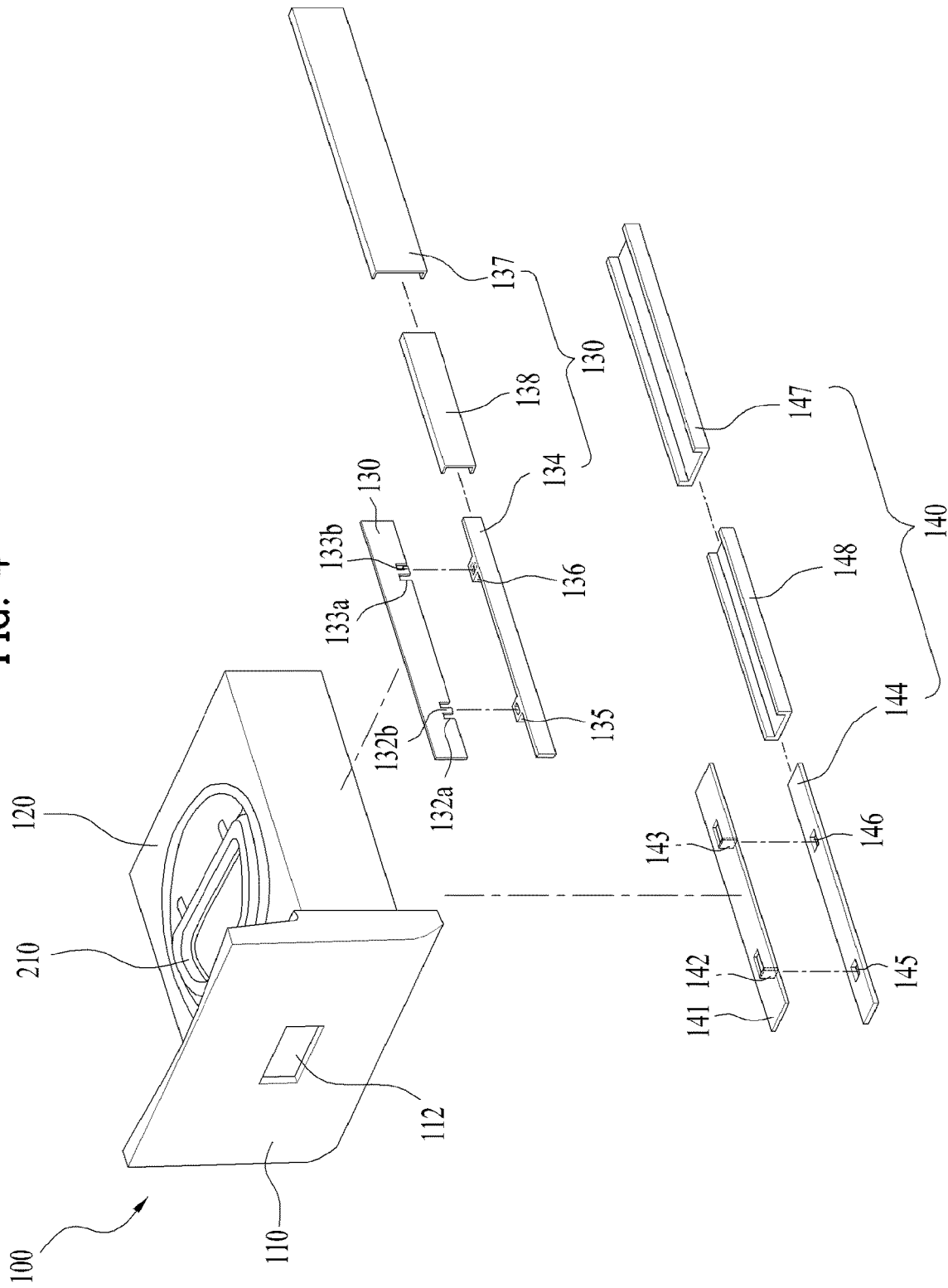

FIG. 5

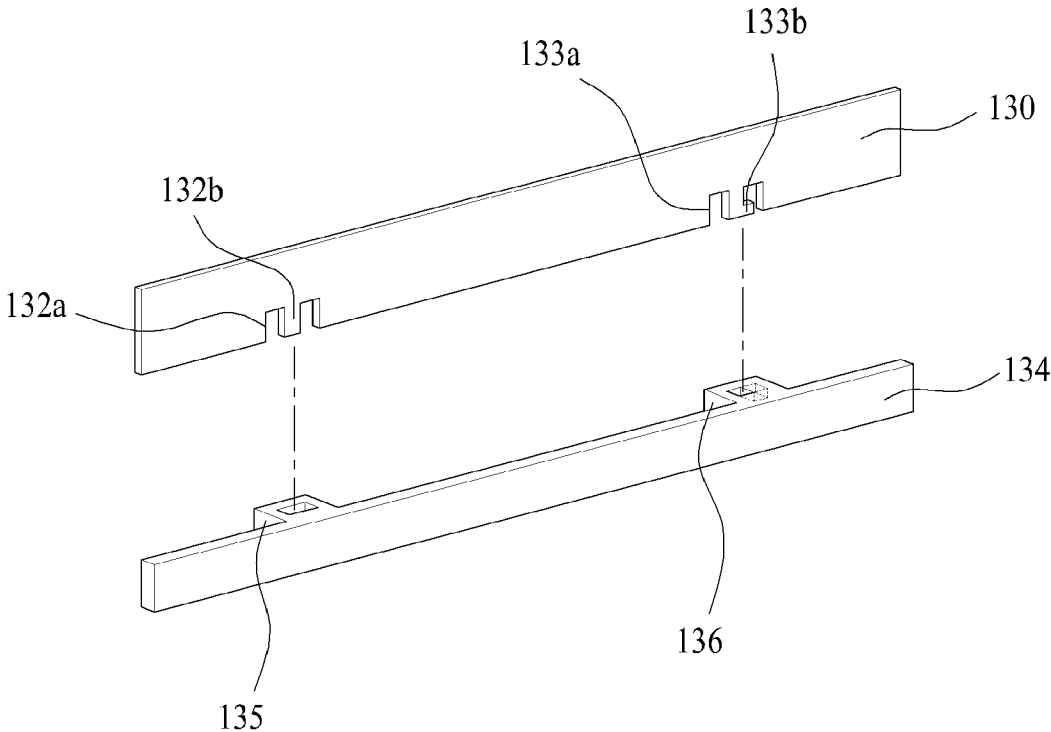



FIG. 6

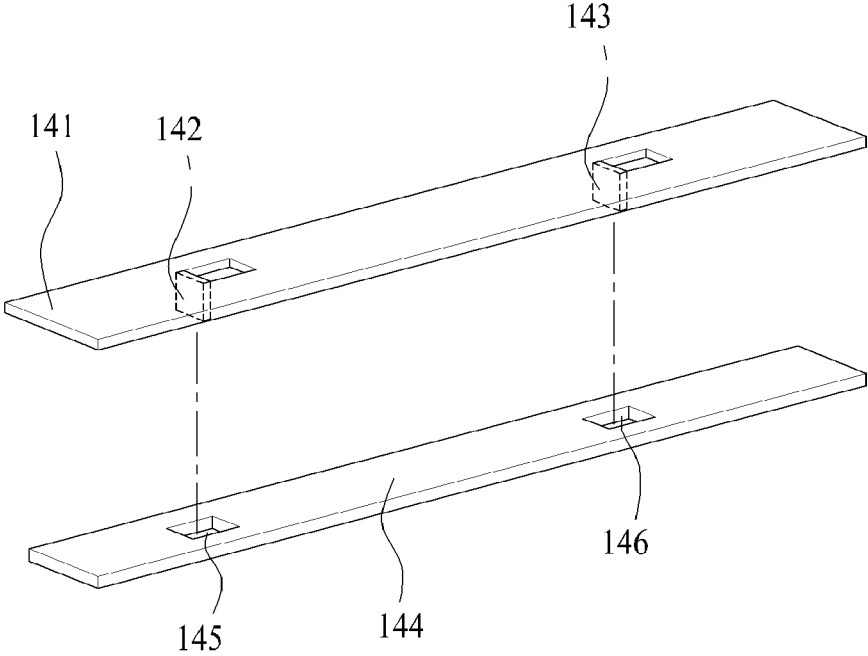

FIG. 7

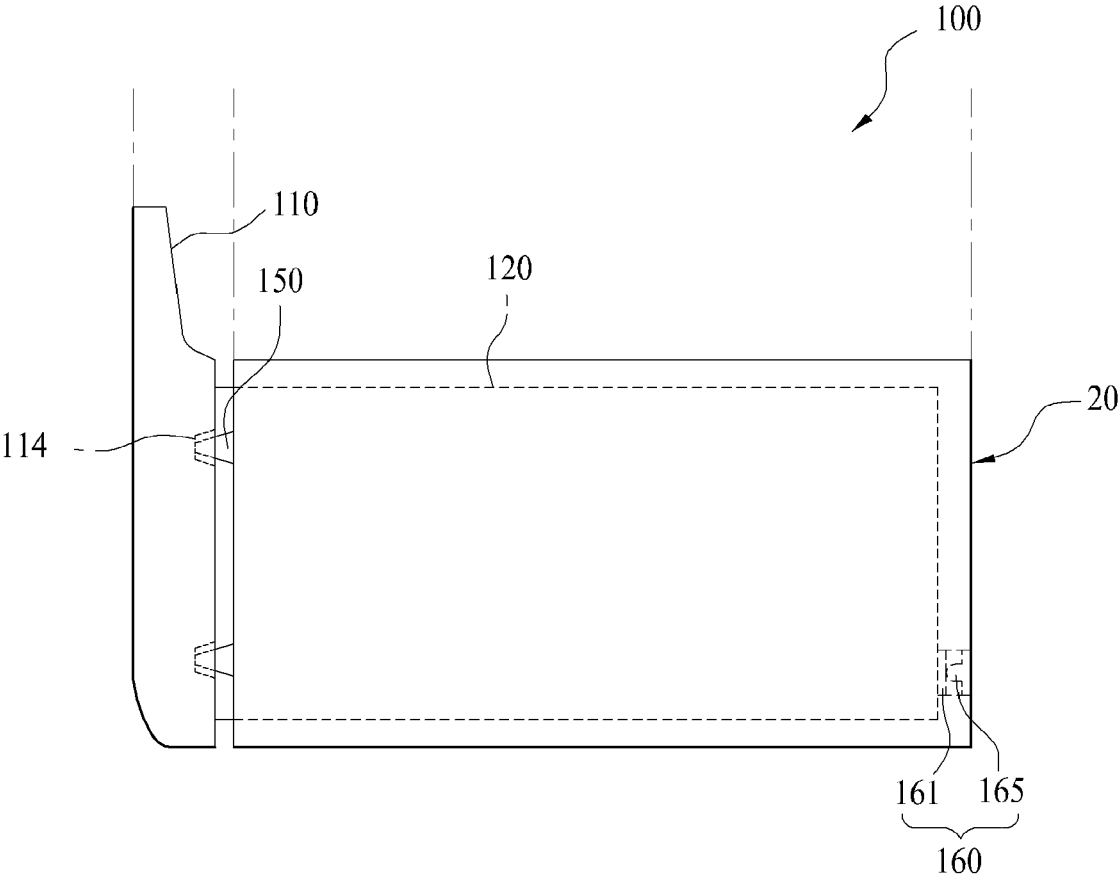

FIG. 8

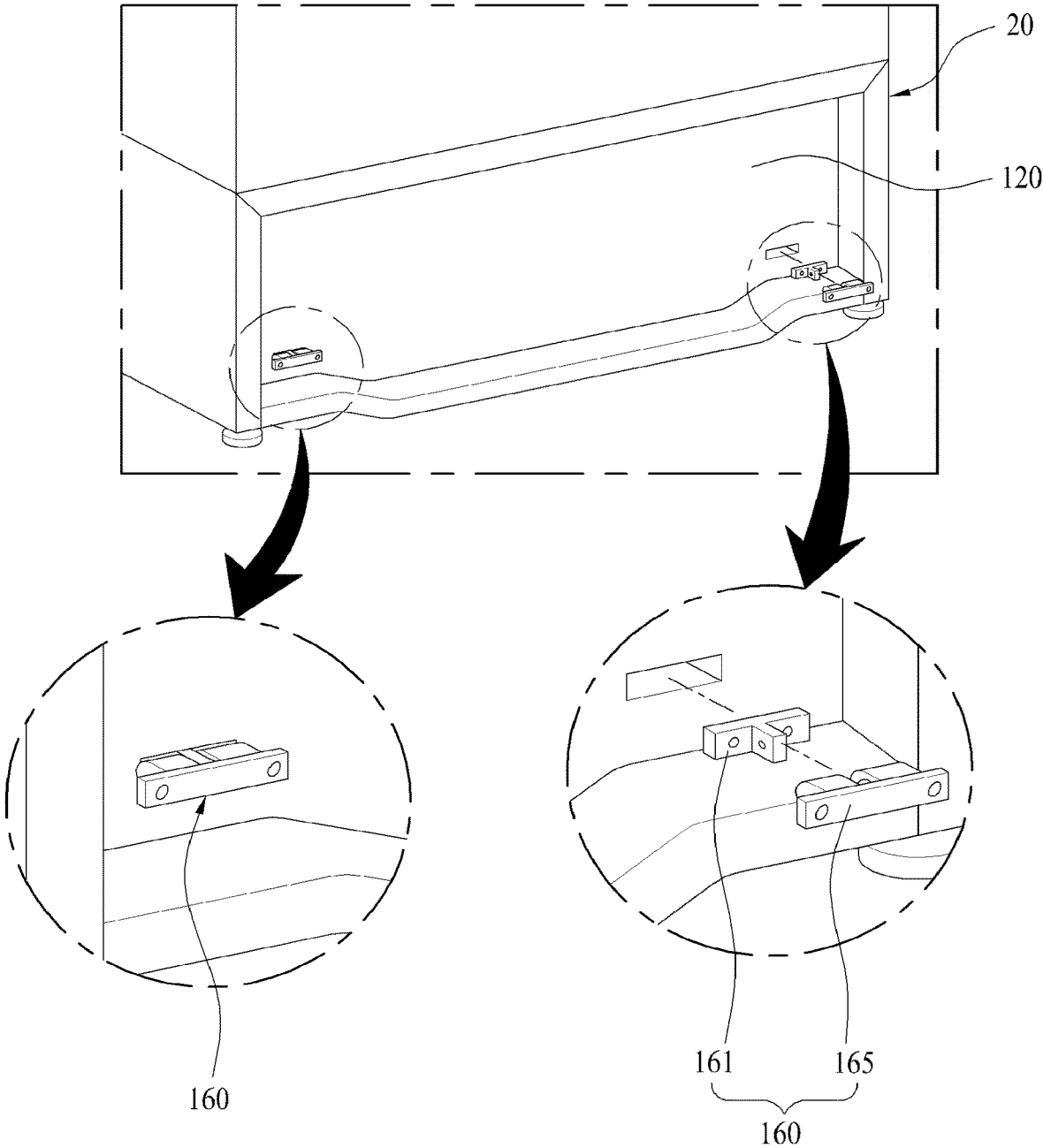

FIG. 9

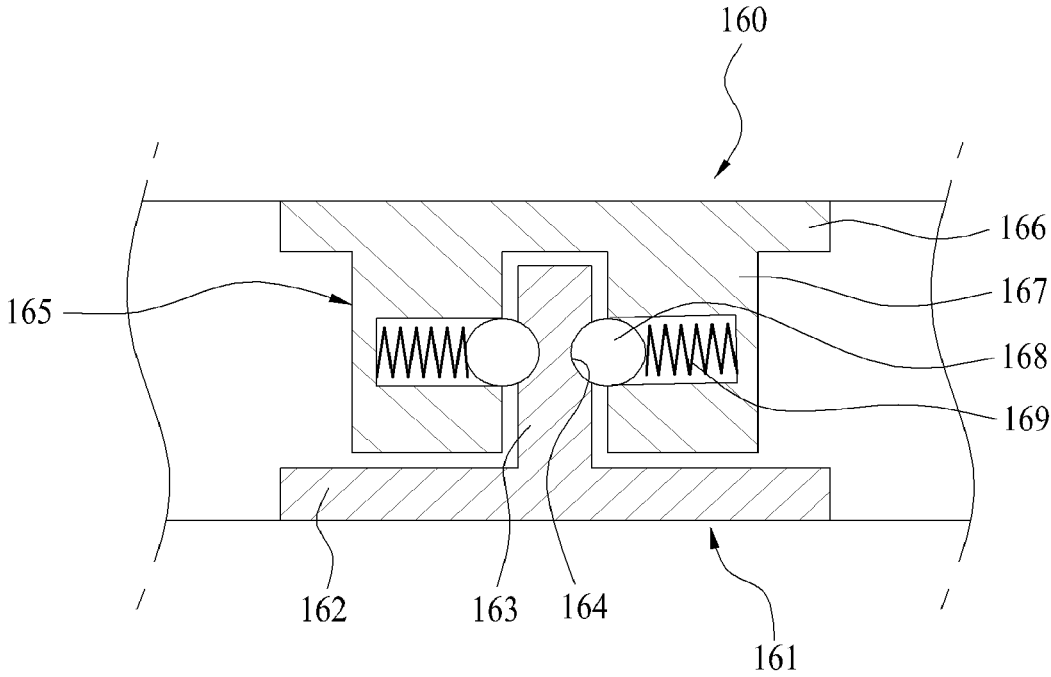

FIG. 10

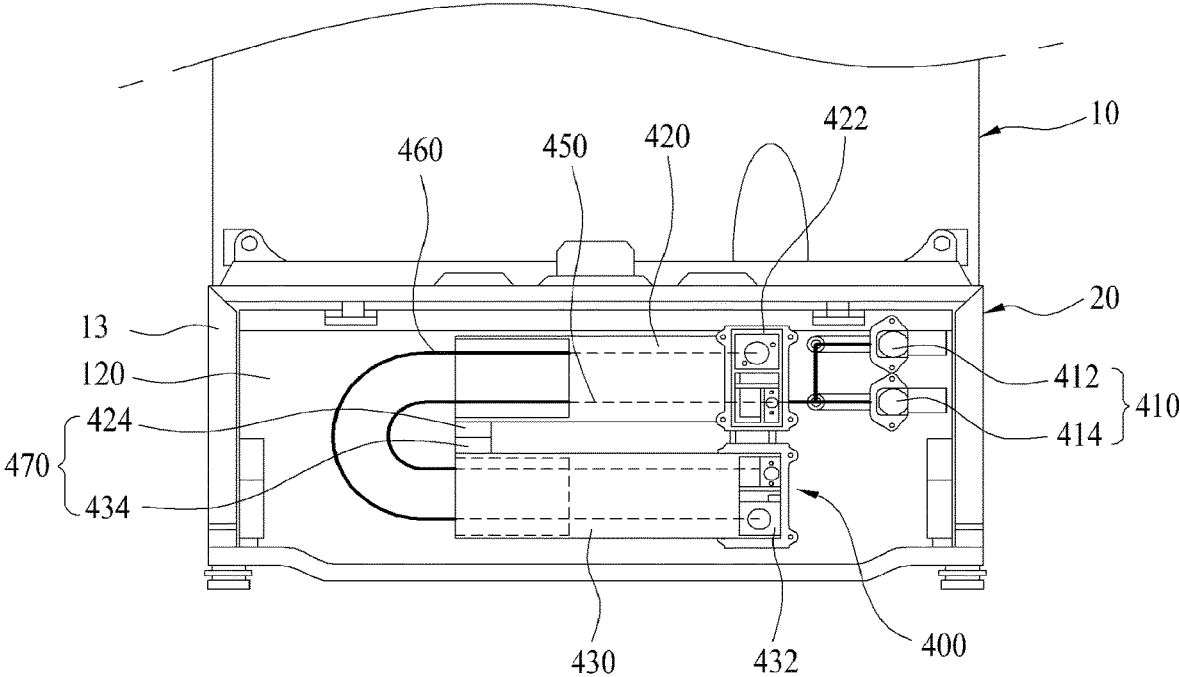

FIG. 11

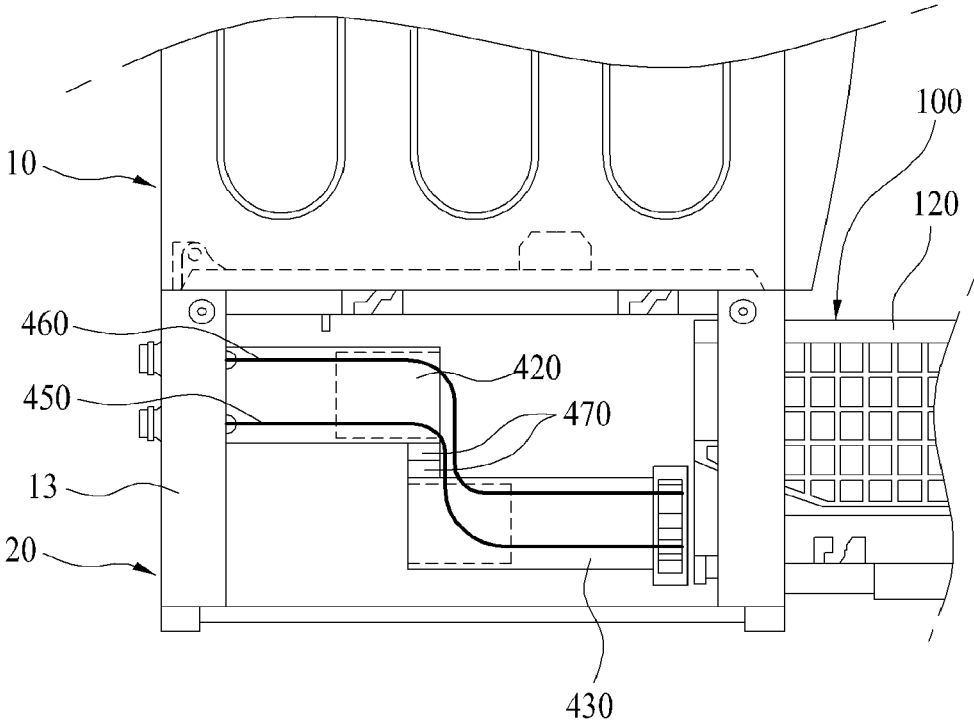

FIG. 12

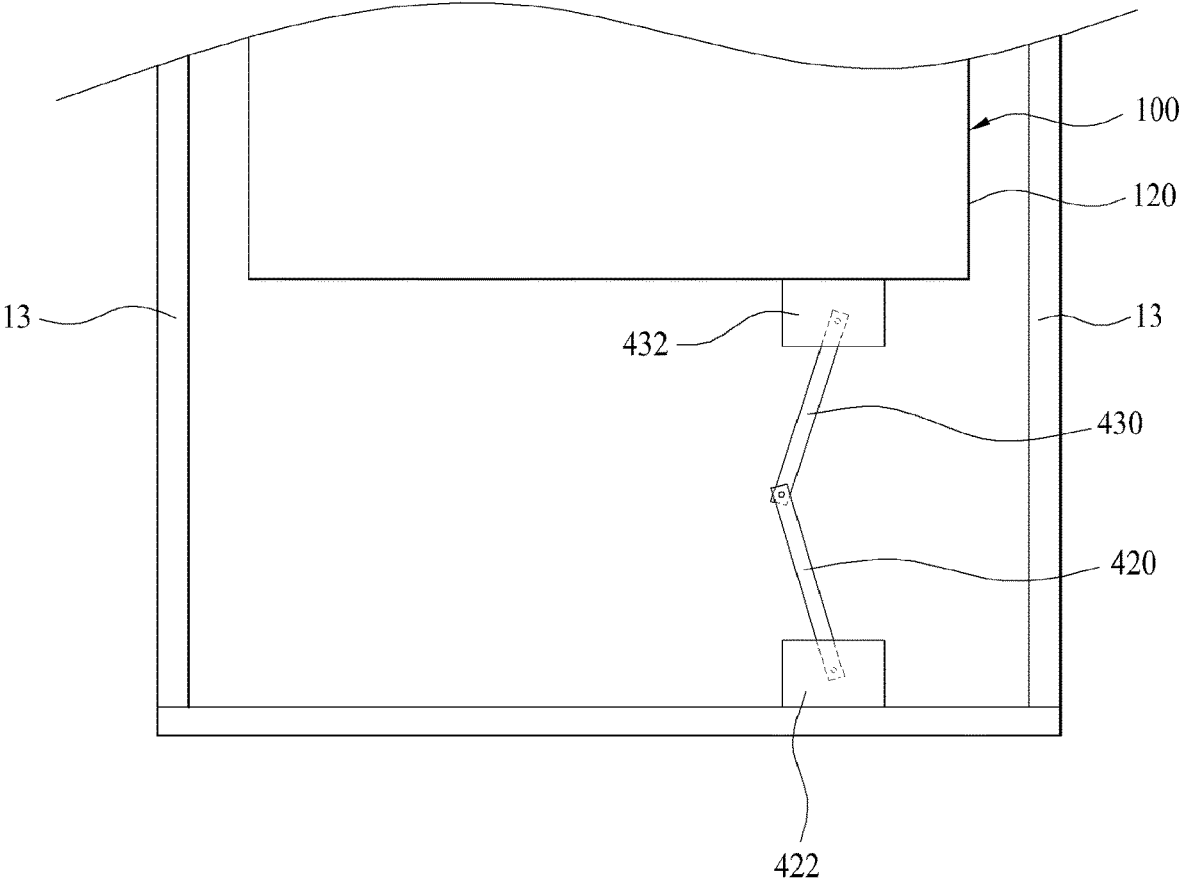

FIG. 13

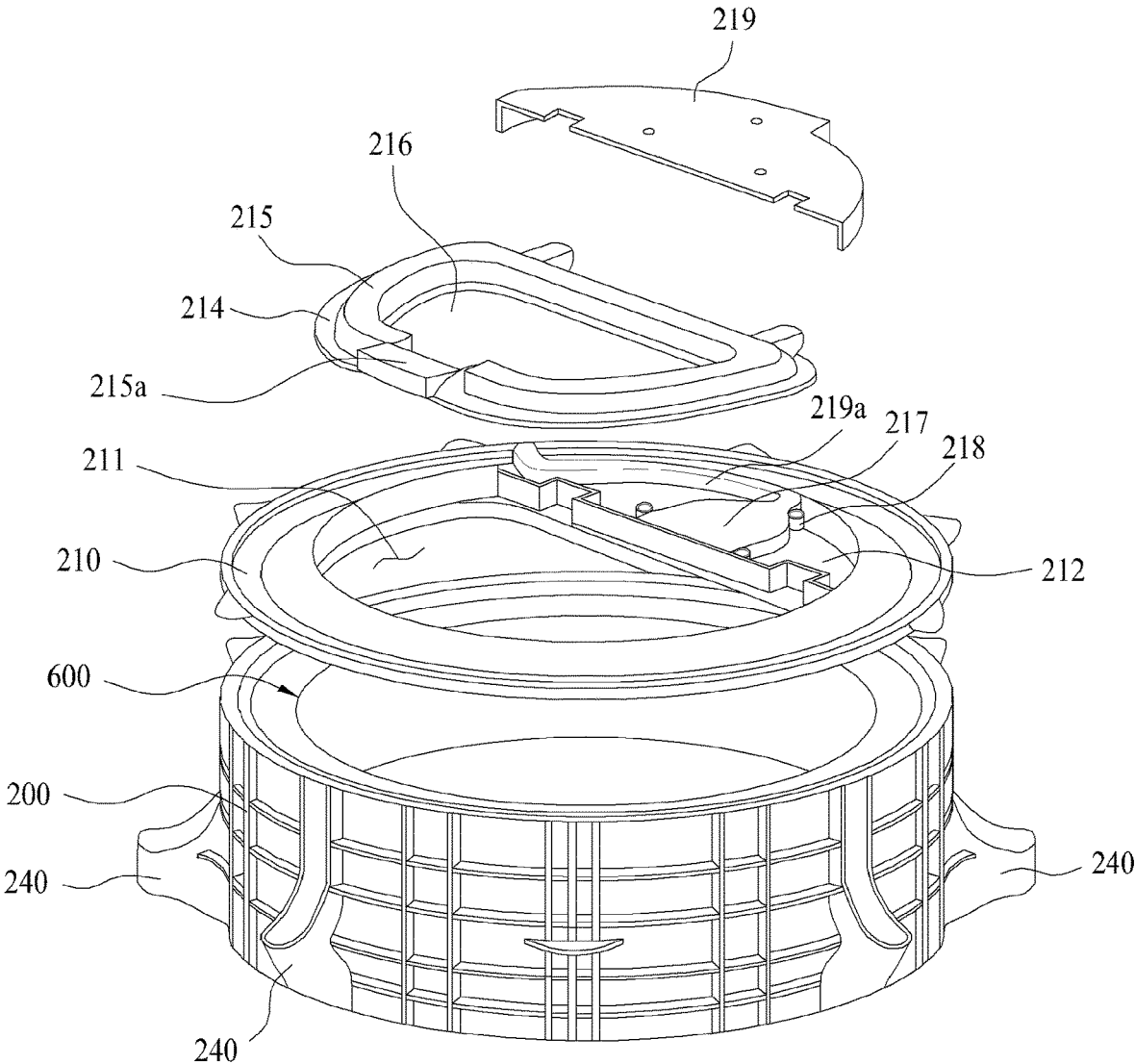



FIG. 14

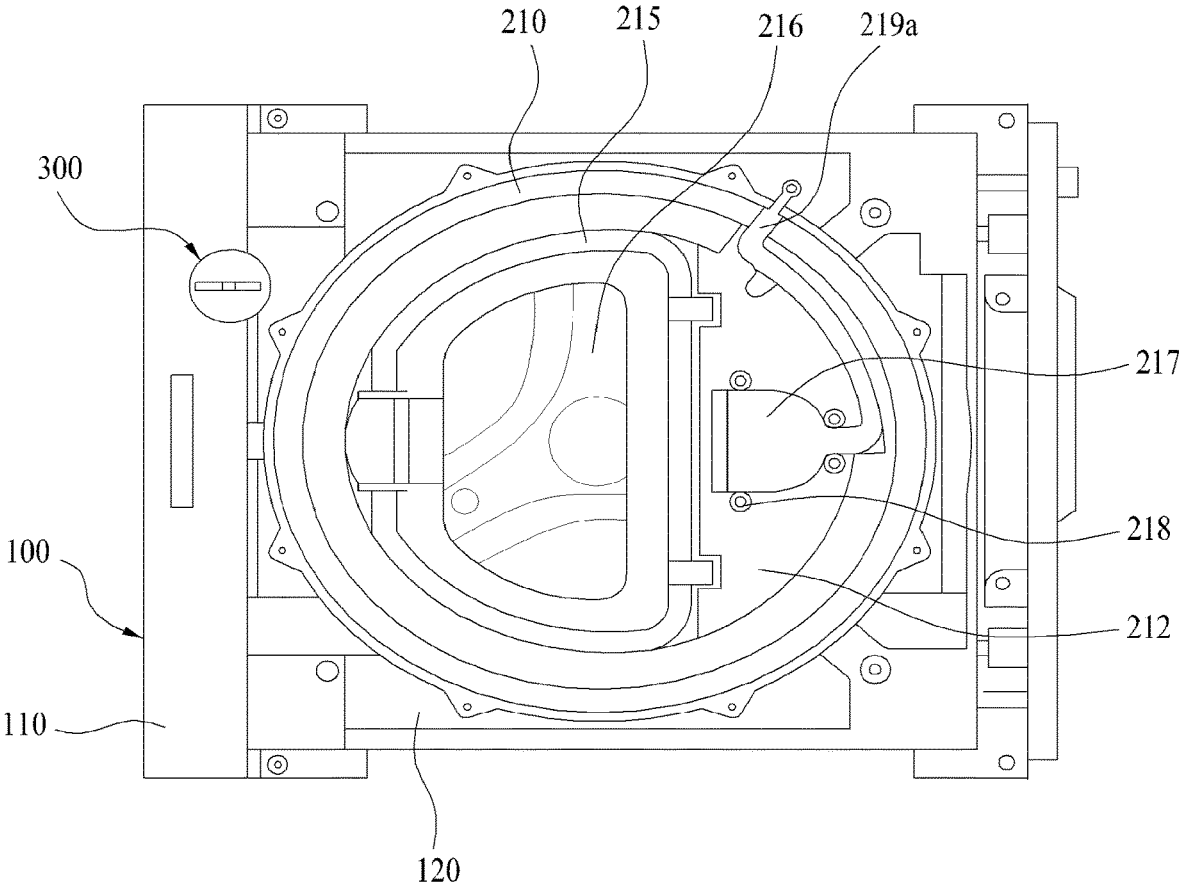

FIG. 15

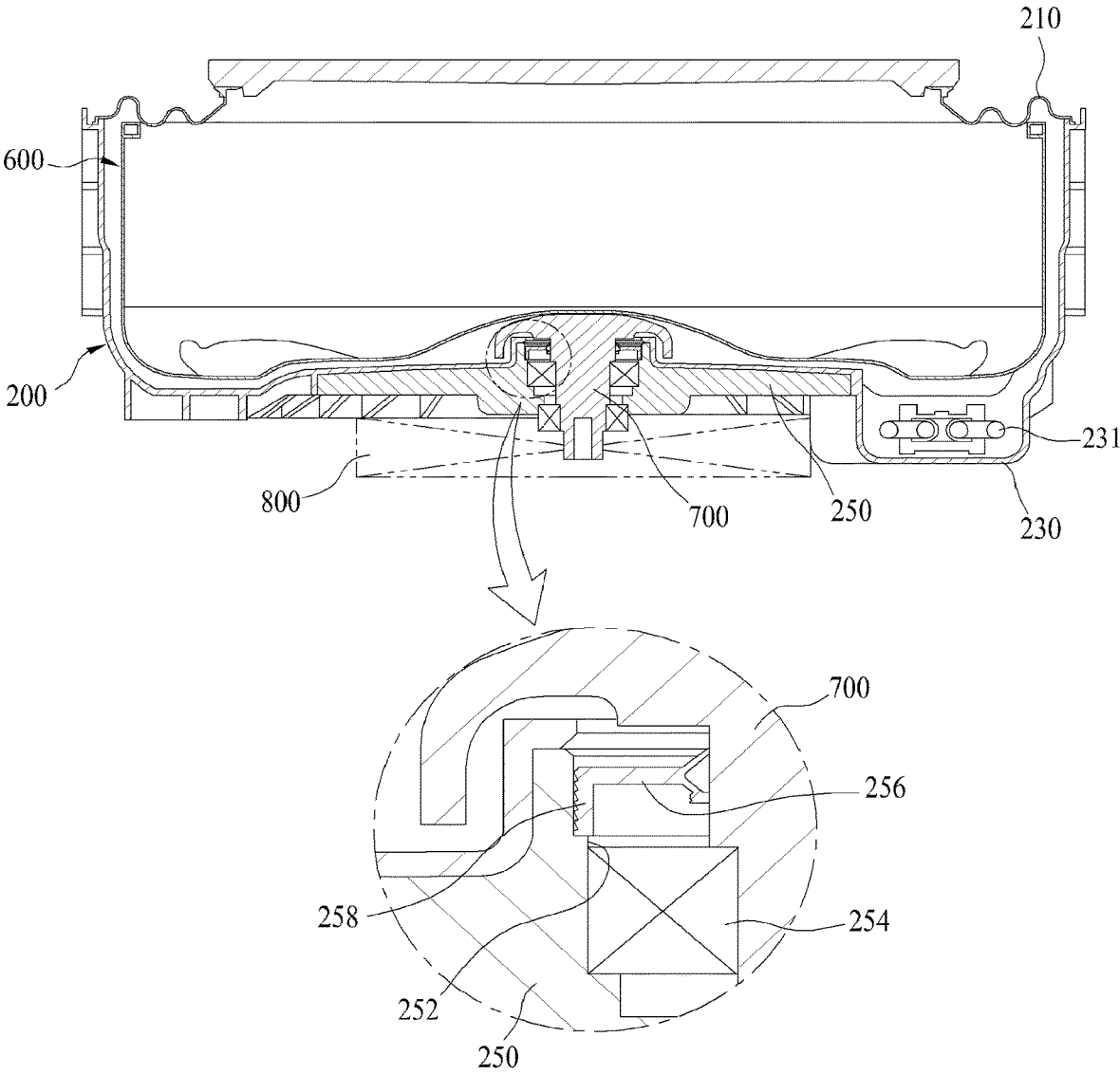

FIG. 16

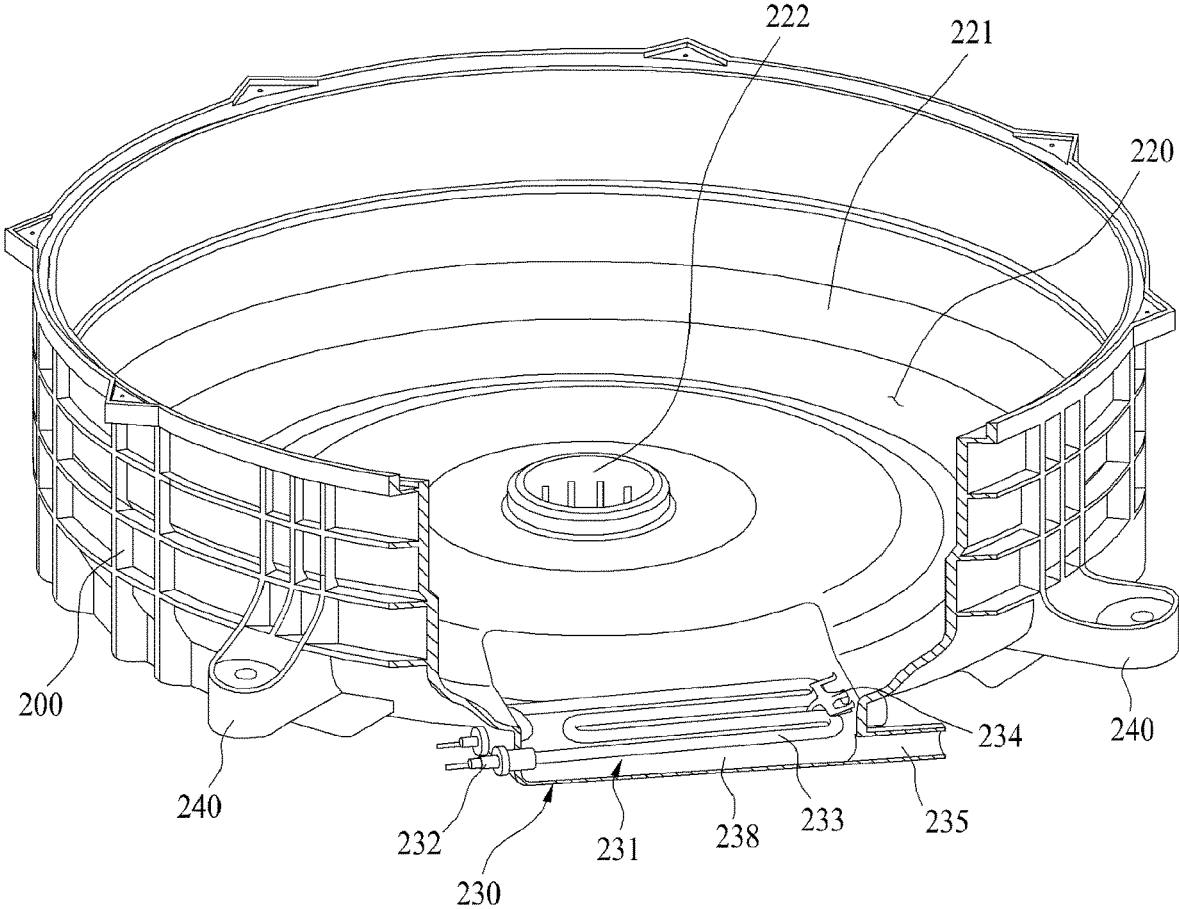

FIG. 17

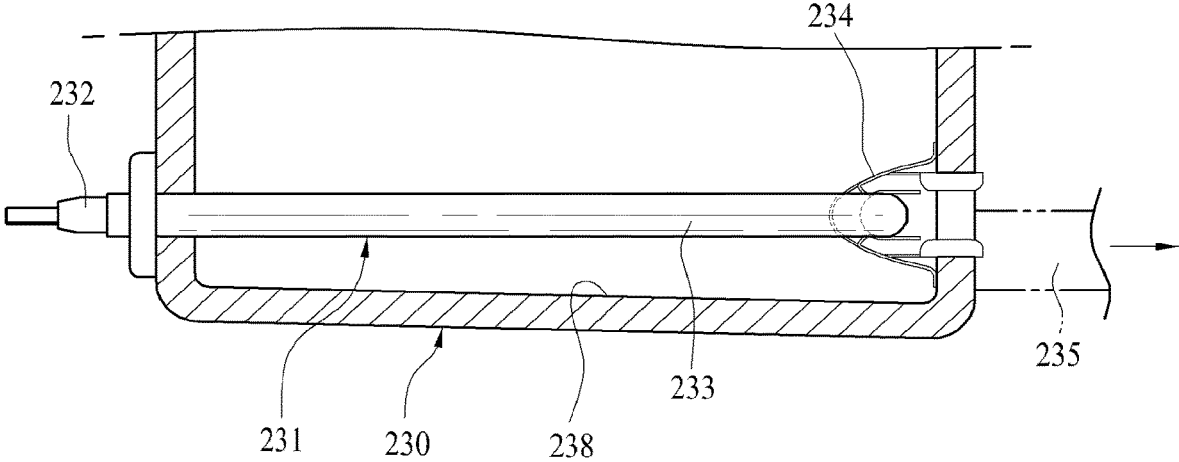

FIG. 18

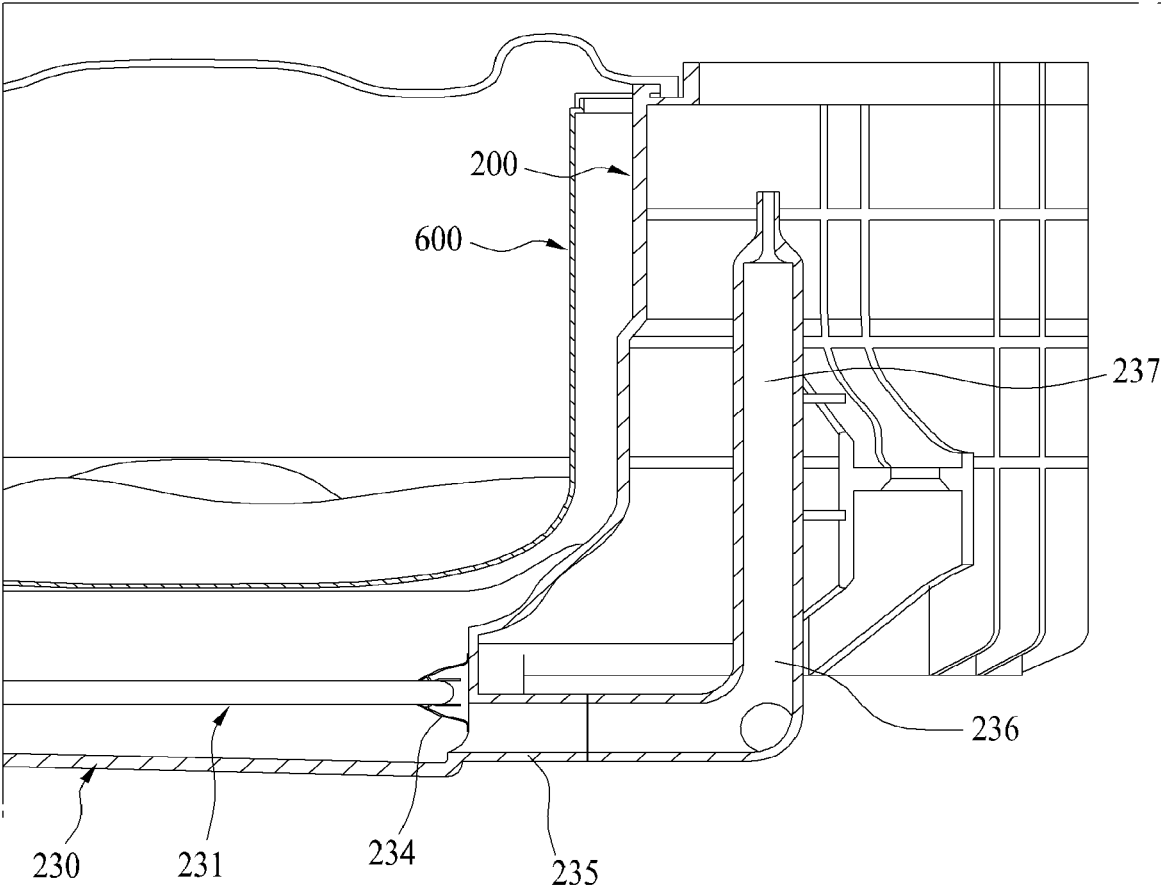

FIG. 19

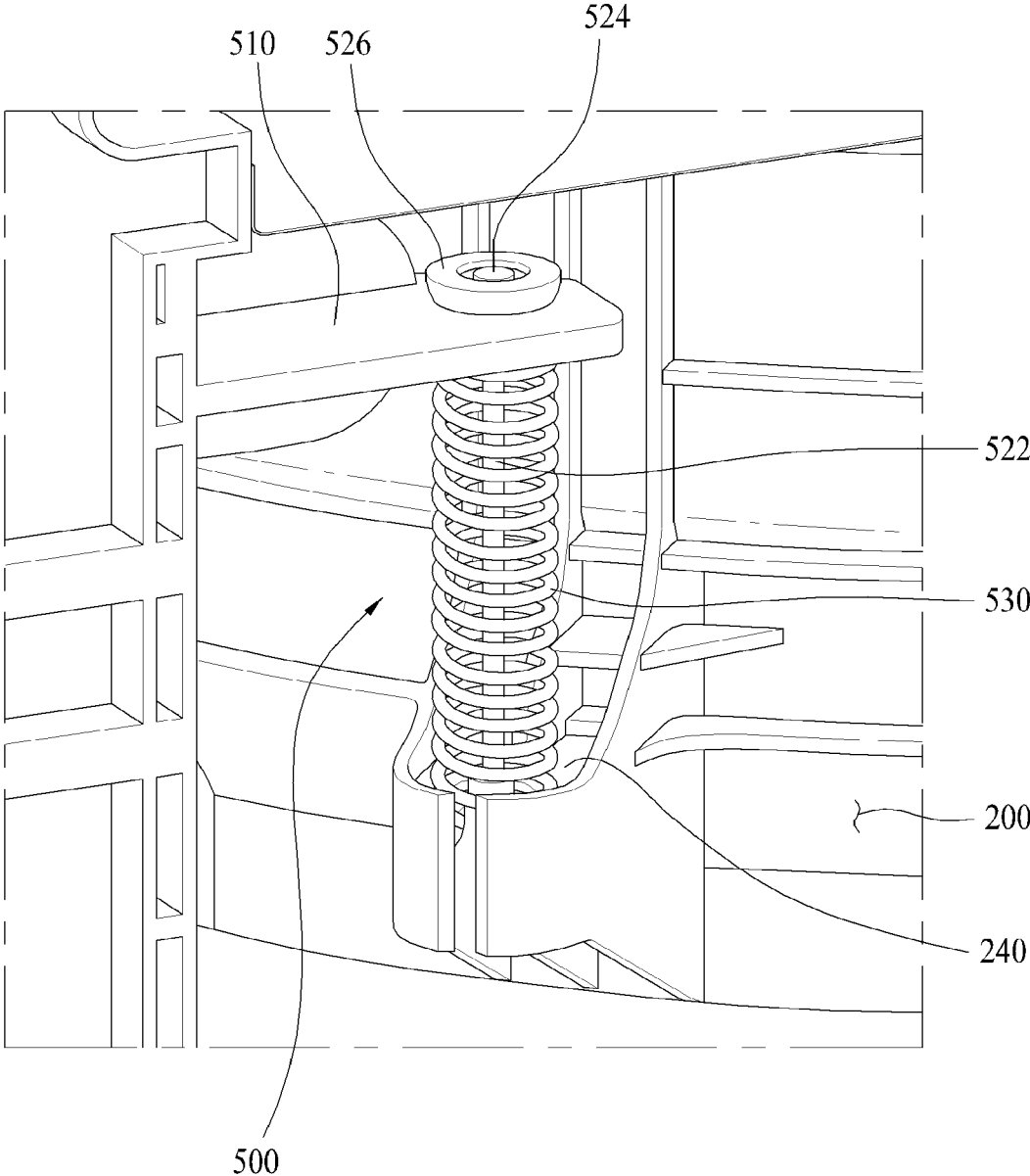

FIG. 20

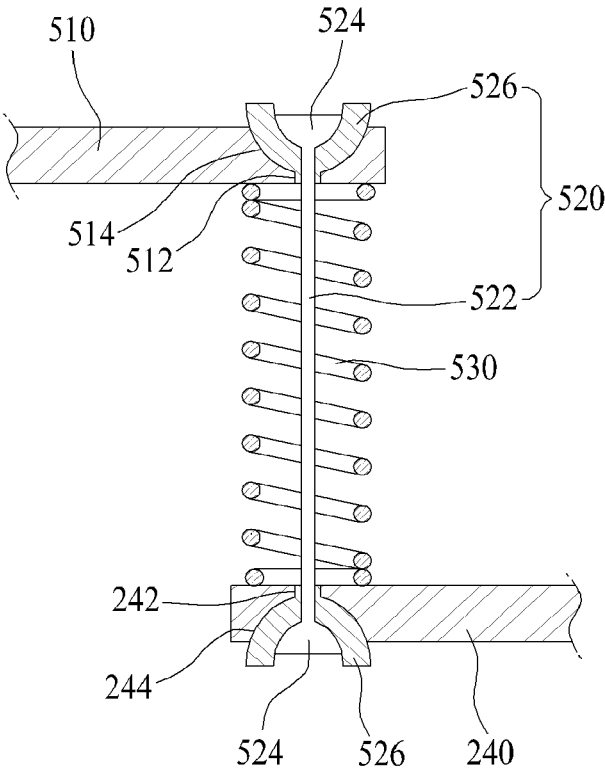

FIG. 21

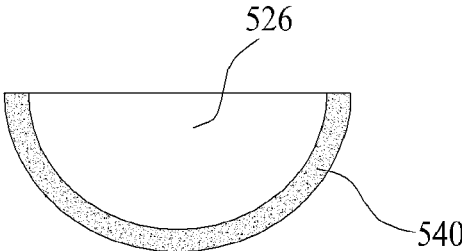

FIG. 22

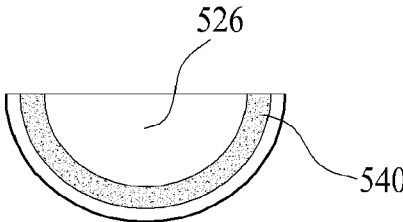



FIG. 23

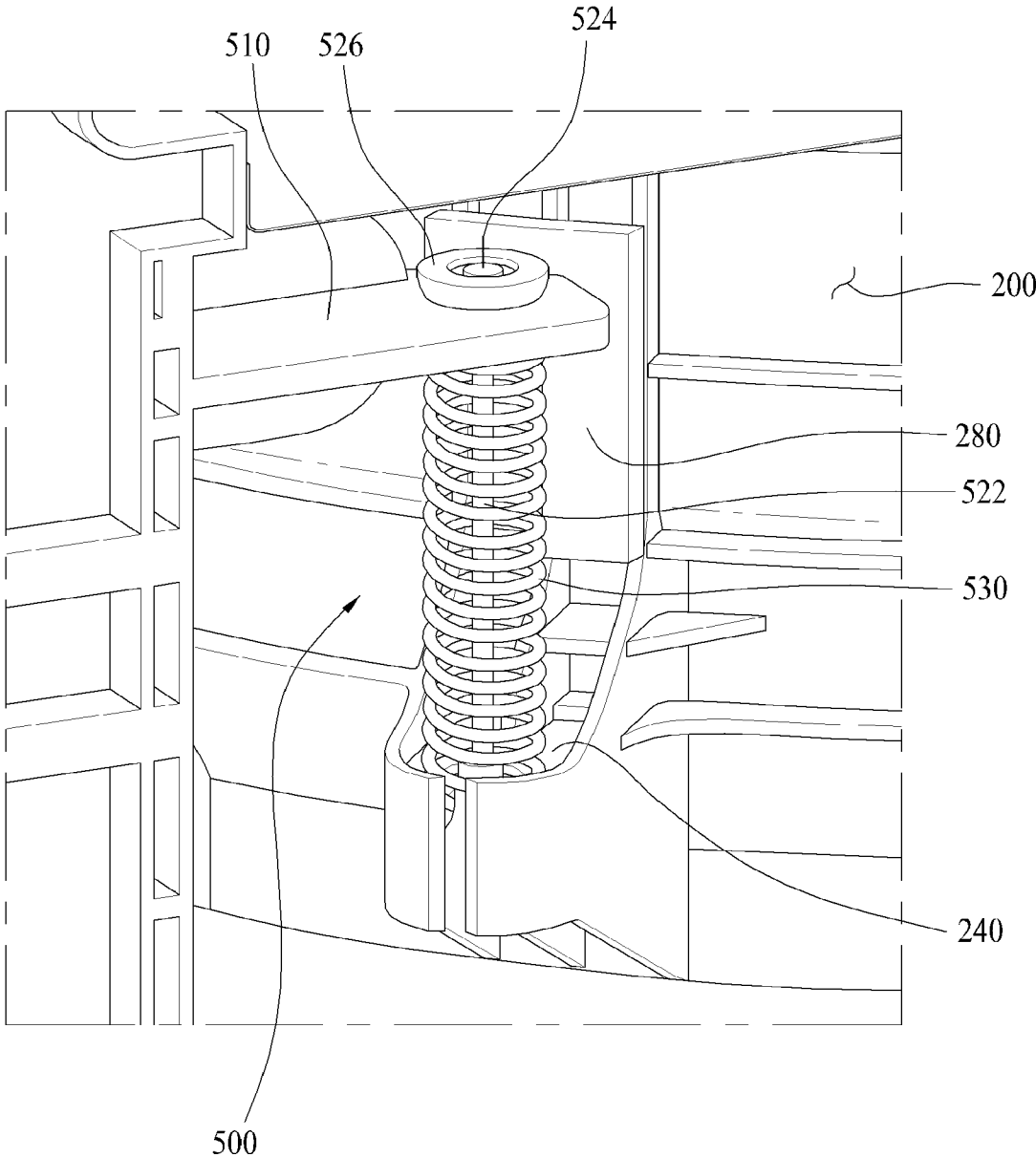

FIG. 24

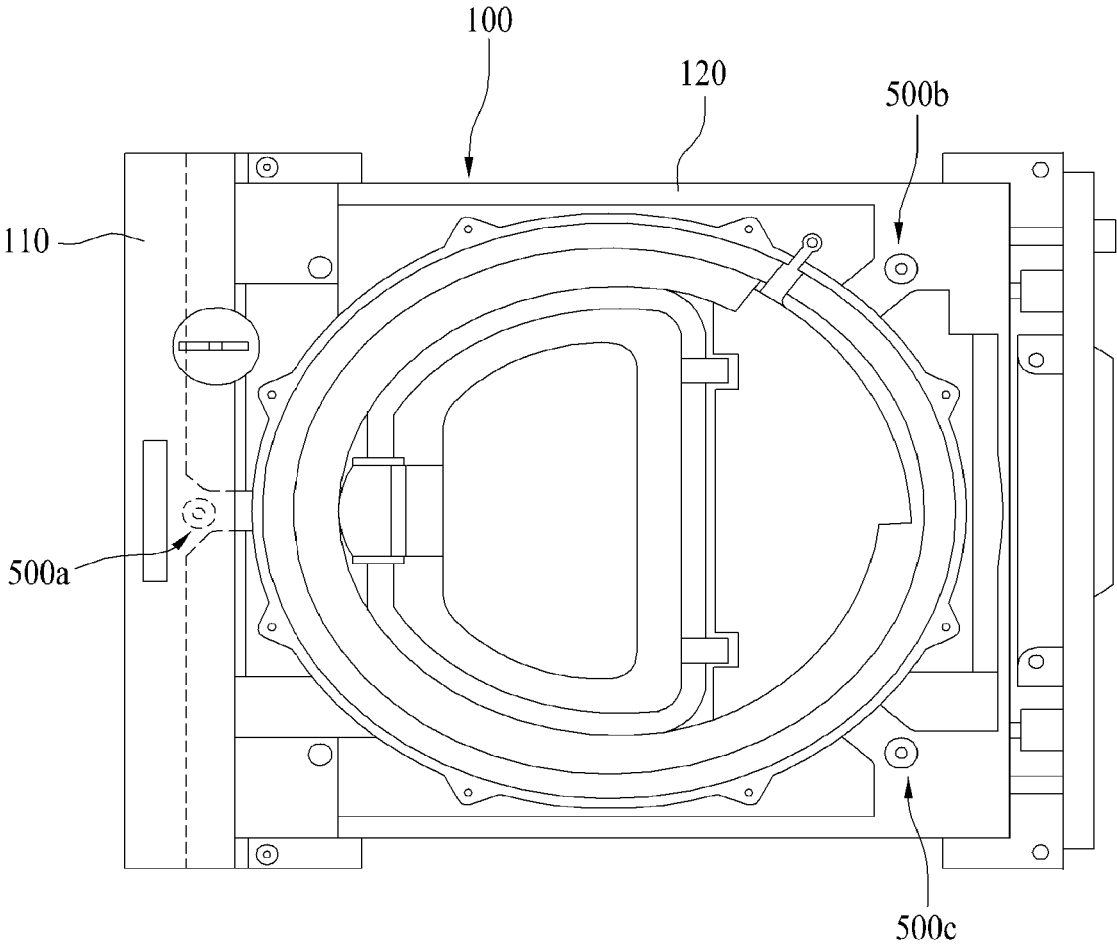

FIG. 25

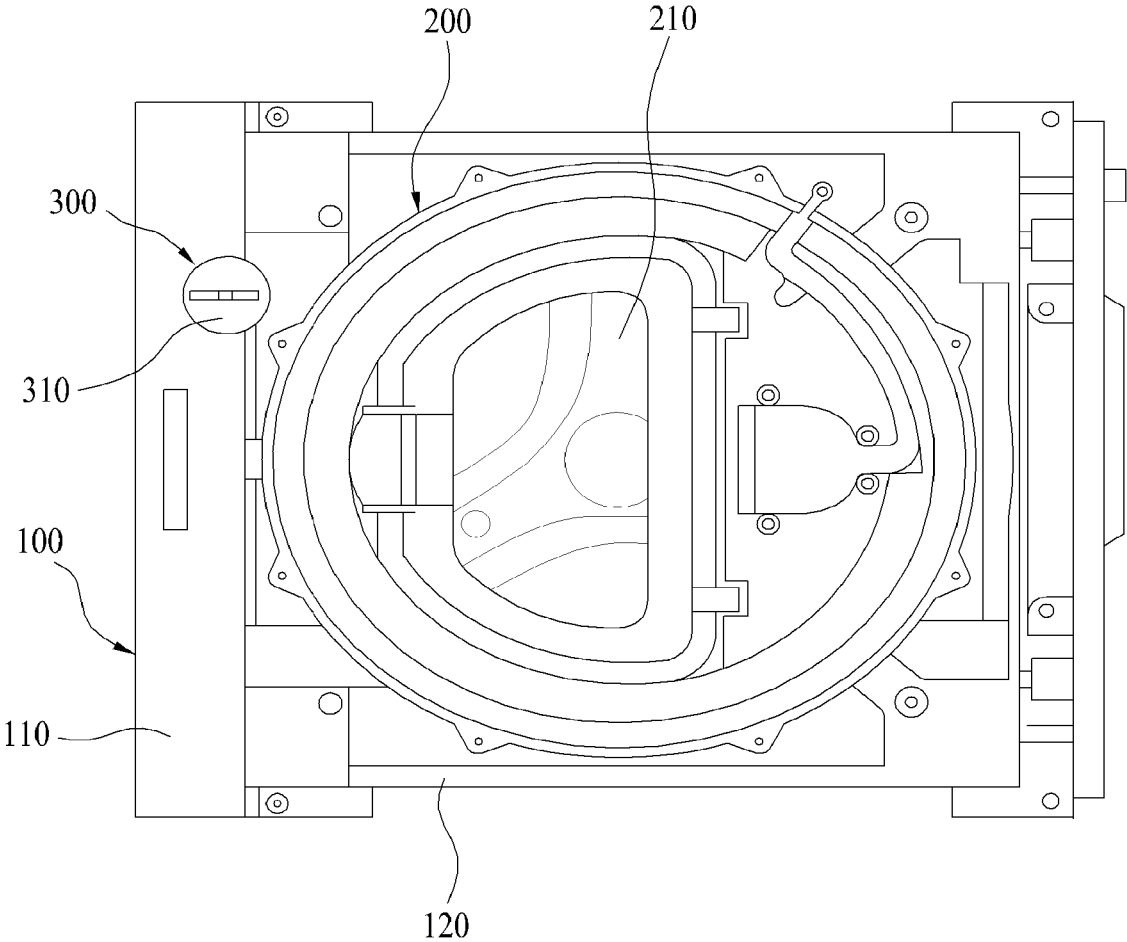

FIG. 26

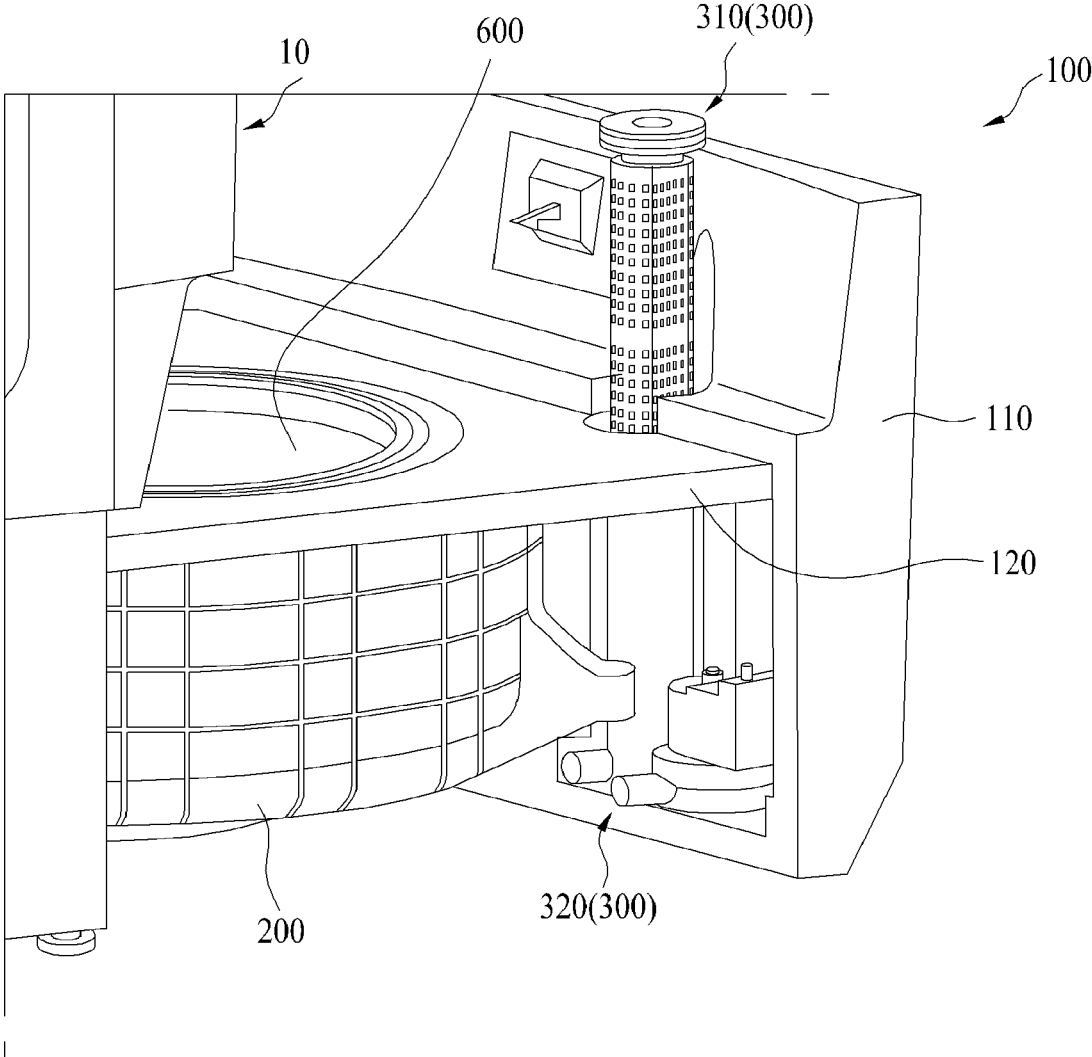

FIG. 27

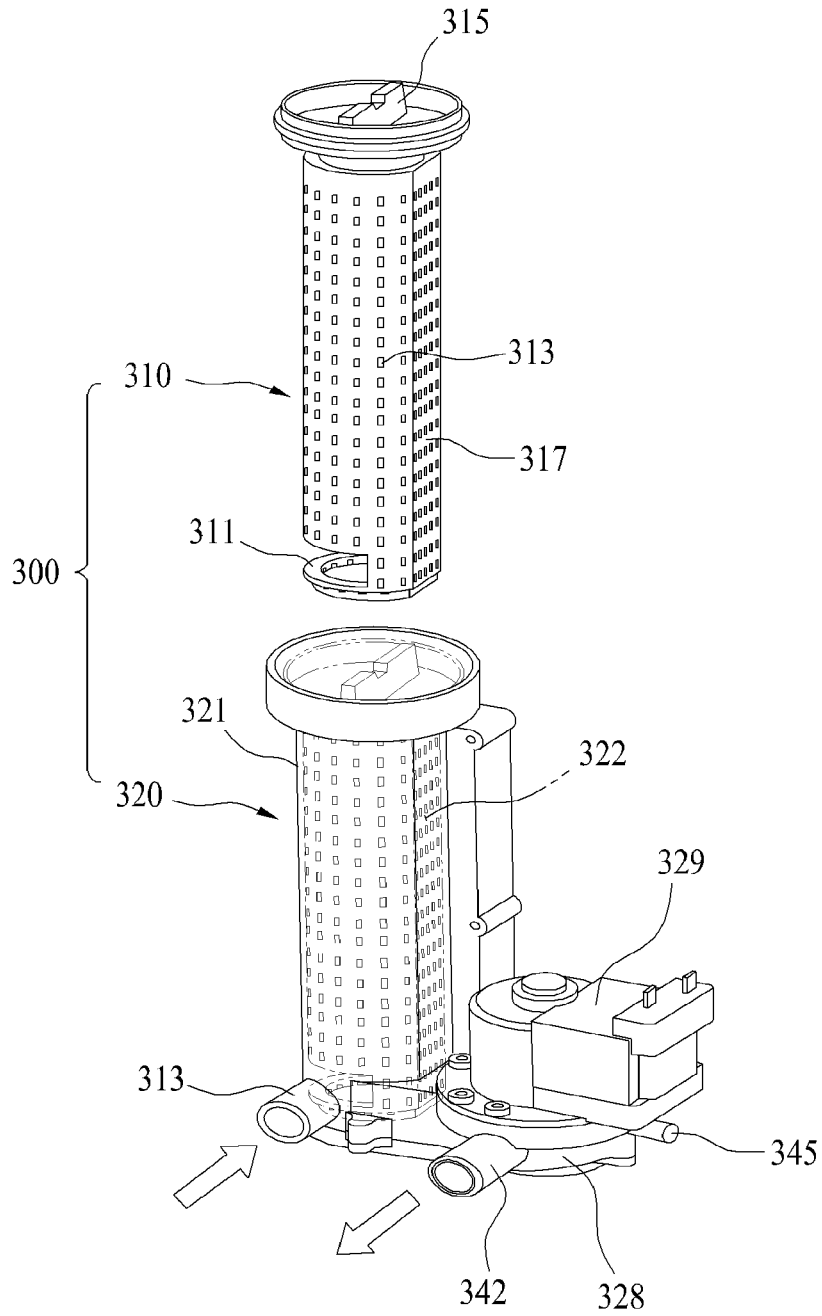

FIG. 28

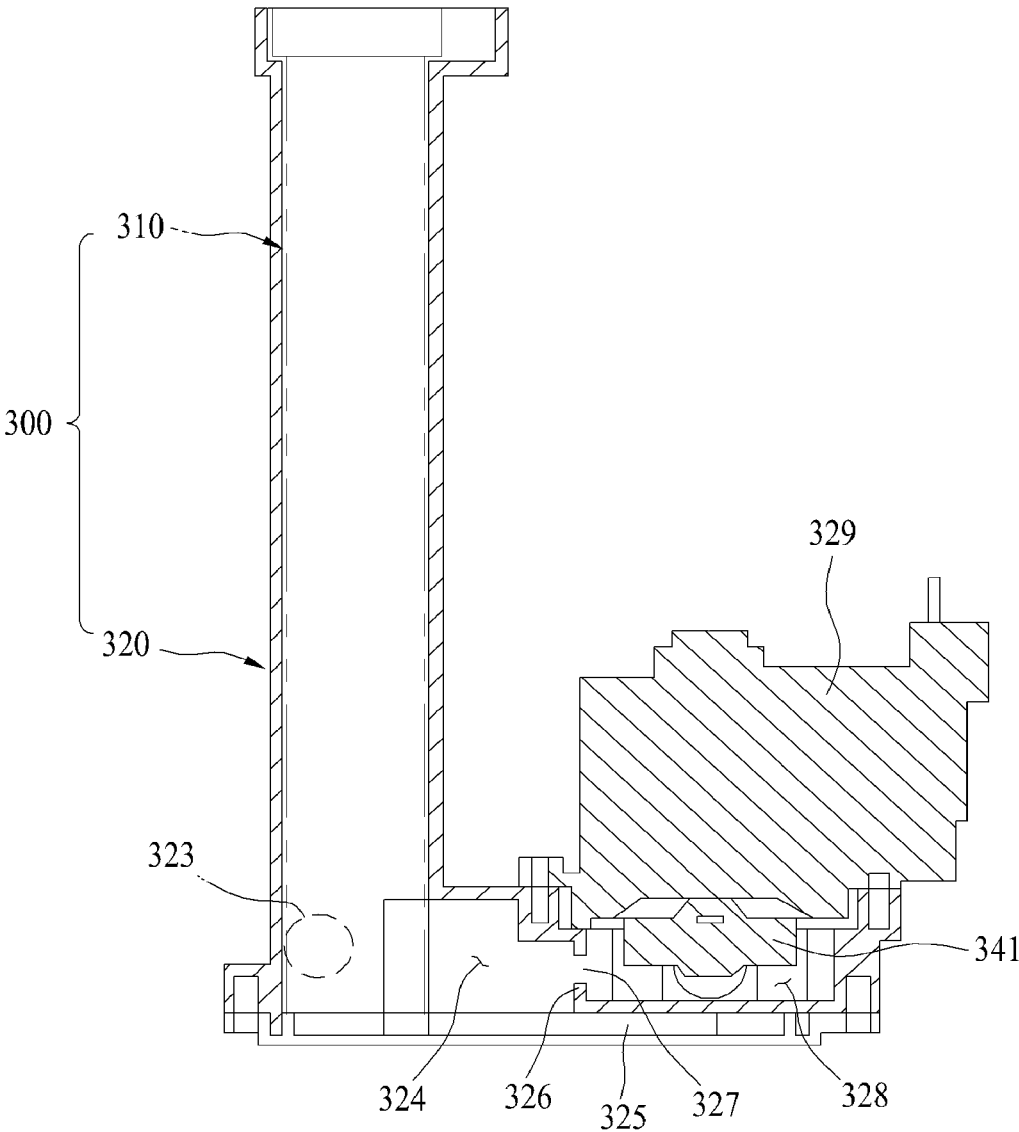

FIG. 29

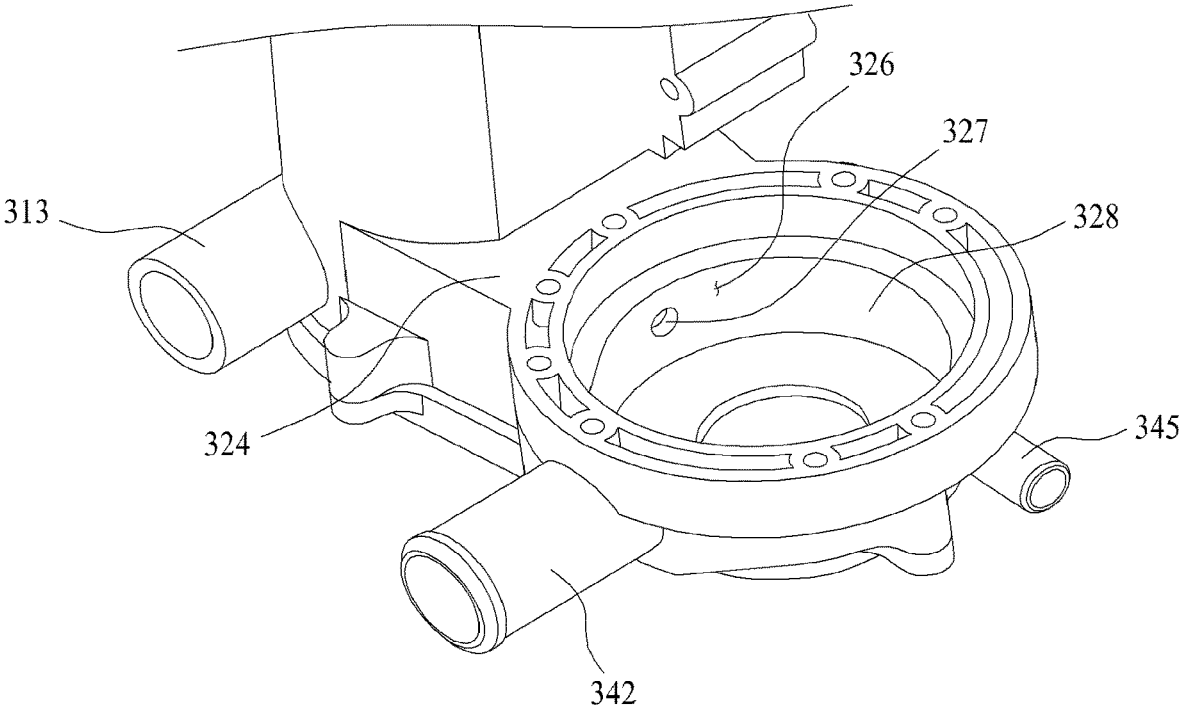

FIG. 30

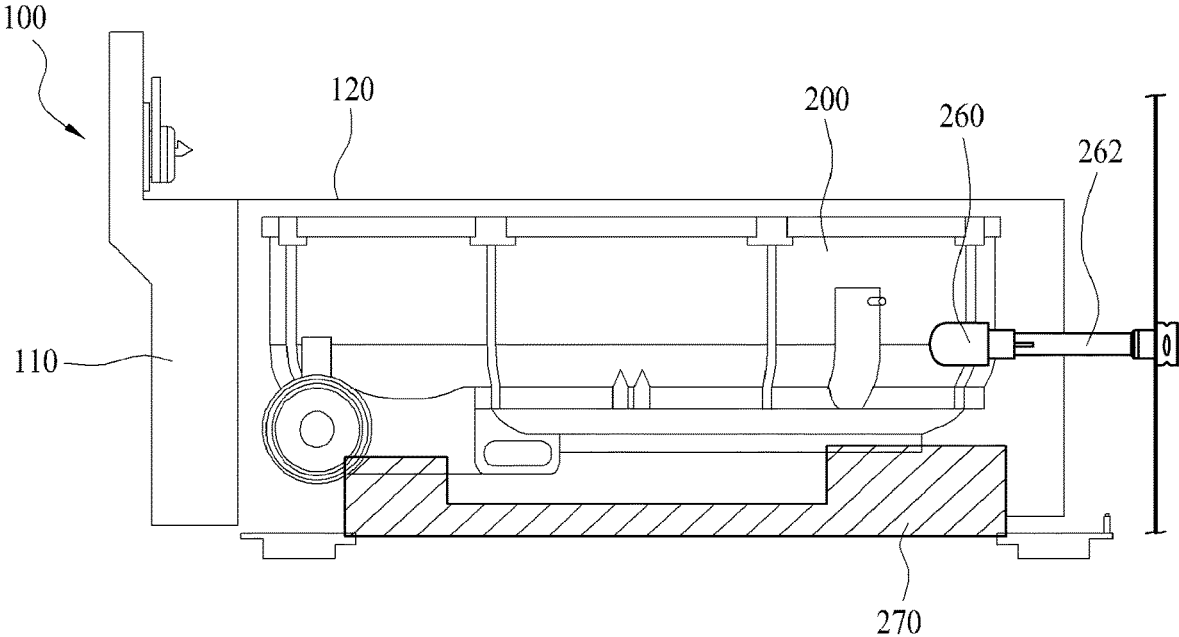



FIG. 31

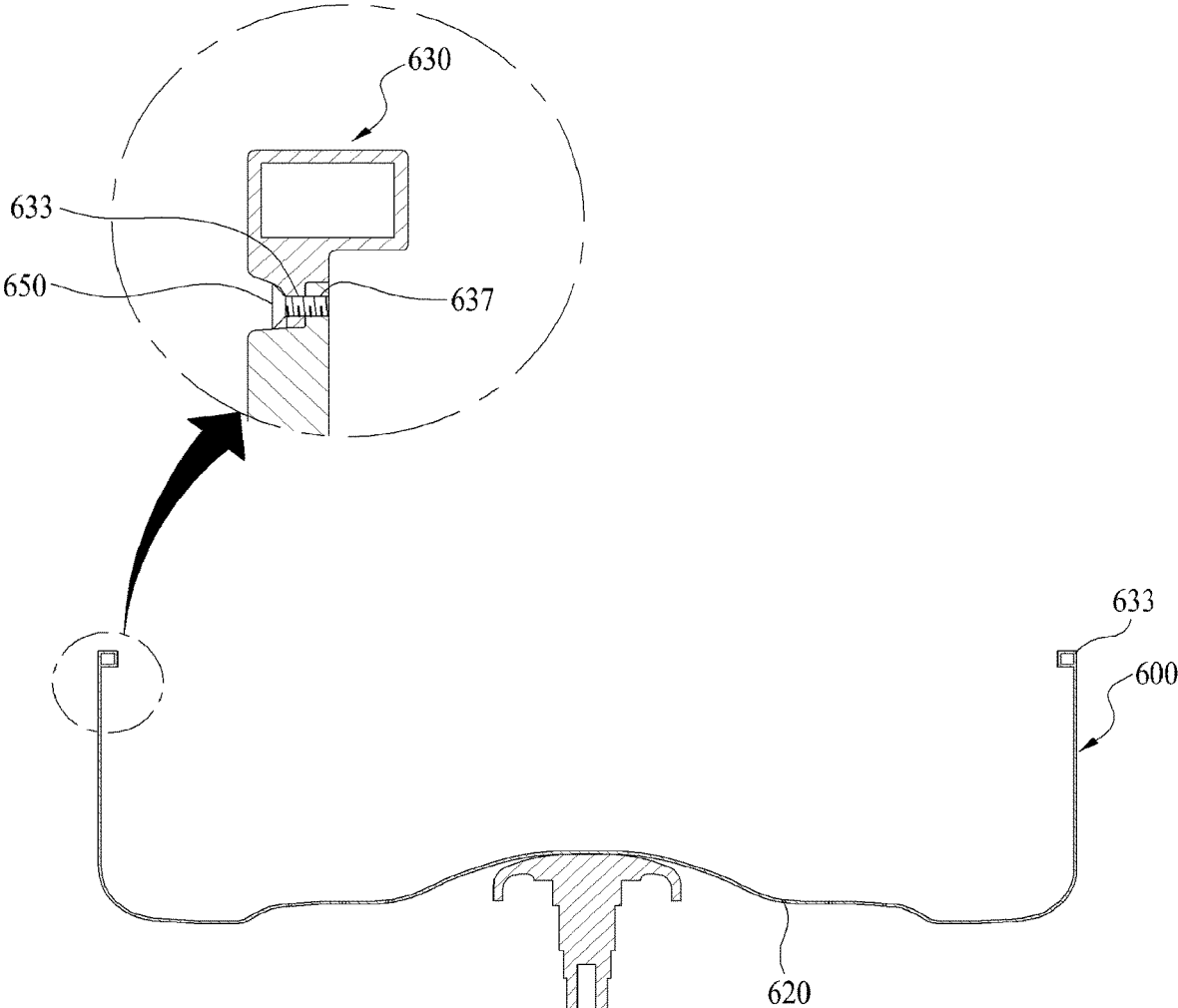

FIG. 32

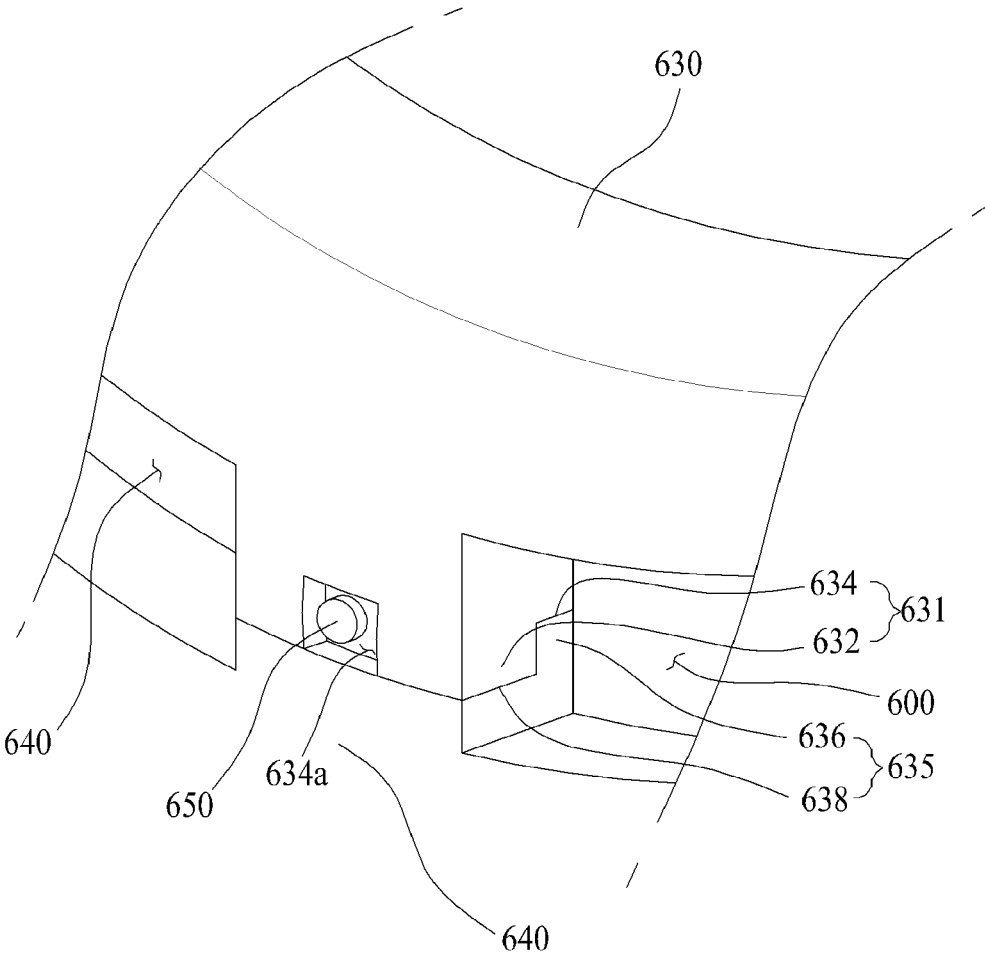

FIG. 33

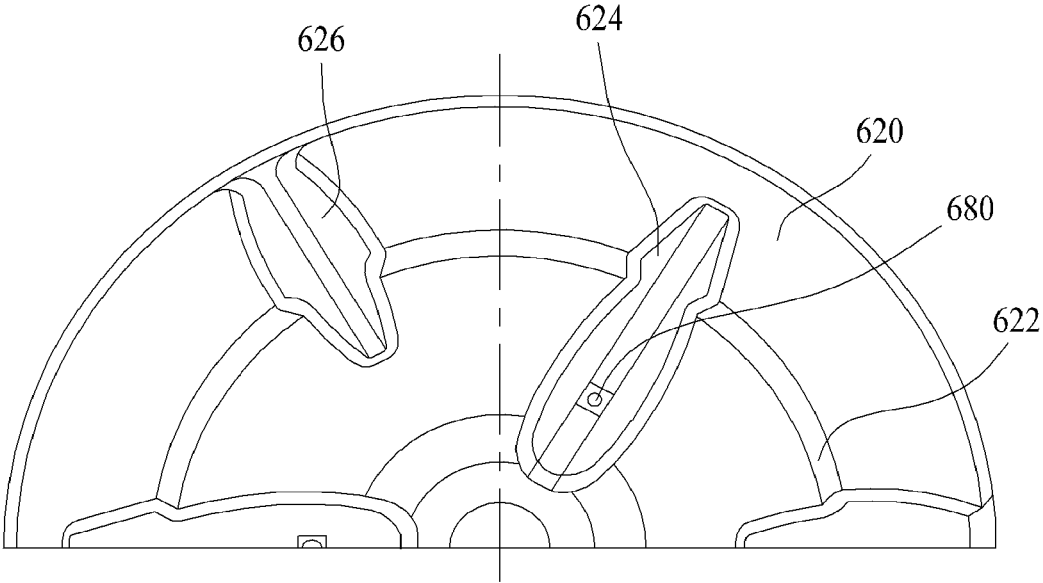

FIG. 34

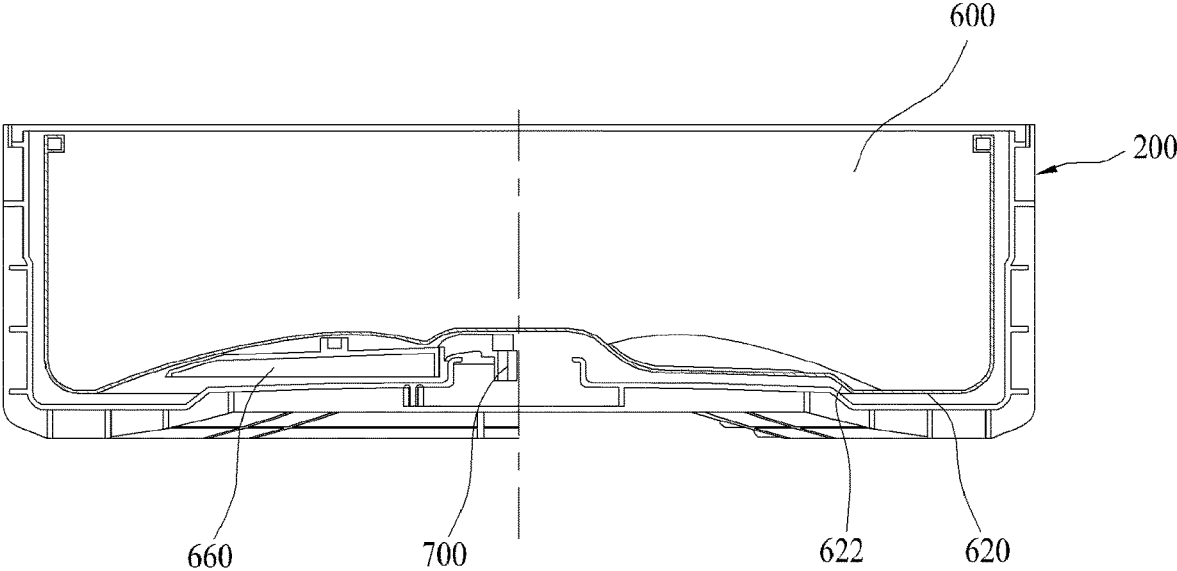
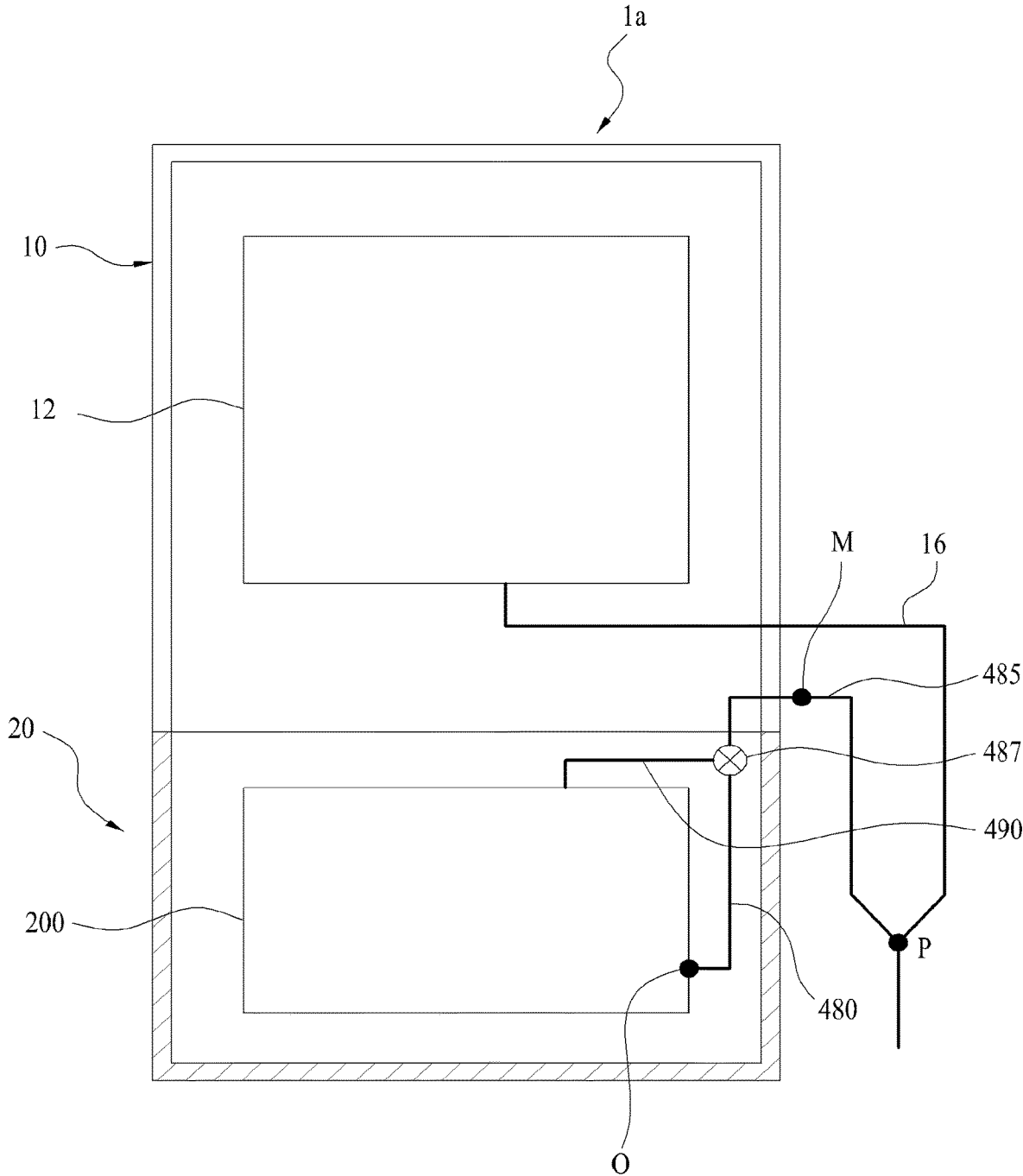

FIG. 35



## LAUNDRY MACHINE

## CROSS REFERENCE TO RELATED APPLICATION

This application is a Continuation Application of U.S. patent Ser. No. 16/217,683, filed on Dec. 12, 2018, now allowed, which is a Divisional Applications of U.S. patent application Ser. No. 15/251,970, filed on Aug. 30, 2016, now U.S. patent Ser. No. 10/179,964, issued on Jan. 15, 2019, which is a Divisional Applications of U.S. patent application Ser. No. 13/097,934, filed on Apr. 29, 2011, now U.S. patent Ser. No. 10/081,898, issued on Sep. 25, 2018, and claims the benefit of the Korean Patent Application Nos. 10-2010-0040526, filed on Apr. 30, 2010, 10-2010-0040625 filed on Apr. 30, 2010, 10-2010-0040624 filed on Apr. 30, 2010, 10-2010-0040527 filed on Apr. 30, 2010, 10-2010-0042004 filed on May 4, 2010 and 10-2010-0050125 filed on May 28, 2010, which are hereby incorporated by reference in their entirety as if fully set forth herein.

## BACKGROUND OF THE DISCLOSURE

## Field of the Disclosure

Embodiments of the present invention relate to a laundry apparatus, more particularly, to a laundry apparatus including an auxiliary laundry device to treat clothes.

## Discussion of the Related Art

In general, laundry apparatuses are electric appliances which can wash laundry by using both detergent and mechanical friction. Such laundry apparatuses can be used together with auxiliary devices for users to use them conveniently.

An auxiliary device may be provided beyond or below a washing apparatus and the auxiliary device provides a user with a variety of supplementary functions. However, the auxiliary devices are designed and manufactured as independent devices provided in the laundry apparatuses.

In the meanwhile, the laundry apparatus is directly installed in the floor. Especially, a front loading laundry apparatus has a laundry introduction opening located relatively low. Because of that, a user has an inconvenience when loading and unloading laundry into or out of the front loading laundry apparatus. To solve this inconvenience, a front loading laundry device has been proposed to include a stand provided there below.

Furthermore, various methods have been proposed to install an auxiliary laundry device in the stand, not simply using the stand as it is.

However, a lot of work may be required to use such a stand as an independent auxiliary device. Typically, the laundry apparatus having the auxiliary laundry device fails to have a good profile.

Compared with a main laundry device, the auxiliary laundry device utilizing the stand has various components configured to treat laundry which are installed in a relatively small space. Because of that, it is quite difficult to design and manufacture the auxiliary laundry device.

## SUMMARY OF THE DISCLOSURE

Accordingly, embodiments of the present invention are directed to a laundry apparatus.

An object of an embodiment of the present invention is to provide a laundry apparatus including an auxiliary laundry device with an enhanced productivity and enhanced profile.

Another object of an embodiment of the present invention is to provide a laundry apparatus which can reduce vibration and noise, when the laundry apparatus includes an auxiliary laundry device.

A further object of further embodiments of the present invention is to provide a laundry apparatus which allows an inner configuration of an auxiliary laundry device to be installed efficiently, even if an inner space of the auxiliary laundry device is quite narrow.

Additional advantages, objects, and features of the disclosure will be set forth in part in the description which follows and in part will become apparent to those having ordinary skill in the art upon examination of the following.

To achieve these objects and other advantages in accordance with the purpose of the invention, as embodied and broadly described herein, a laundry apparatus includes a cabinet; a first space provided in the cabinet, the first space in which a first treating part provided to treat laundry is installed; a second space provided in the cabinet, the first space in which a second treating part provided to treat laundry is installed; a drawer movably provided in the second space, the drawer in which the second treating part is installed; and a rail unit configured to limit vertical and horizontal movement of the drawer with respect to the second space to guide the outward movement of the drawer.

It is to be understood that both the foregoing general description and the following detailed description are exemplary and explanatory and are intended to provide further explanation of the invention as claimed.

## BRIEF DESCRIPTION OF THE DRAWINGS

The accompanying drawings, which are included to provide a further understanding of the disclosure and are incorporated in and constitute a part of this application, illustrate embodiment(s) of the disclosure and together with the description serve to explain the principle of the disclosure.

In the drawings:

FIGS. 1 and 2 are perspective views illustrating a laundry apparatus according to an exemplary embodiment of the present invention;

FIG. 3 is a perspective view illustrating a bottom surface of the laundry apparatus;

FIG. 4 is an exploded perspective view illustrating a drawer provided in the laundry apparatus;

FIGS. 5 and 6 are perspective views illustrating a rail of the laundry apparatus;

FIG. 7 is a side sectional view illustrating a second cabinet of the laundry apparatus;

FIG. 8 is a perspective view illustrating an installation state of a rear lock provided in the laundry apparatus;

FIG. 9 is a sectional view illustrating the rear lock of the laundry apparatus;

FIG. 10 is a rear view illustrating a water supply and drainage device of the laundry apparatus;

FIG. 11 is a side view illustrating the water supply and drainage device of the laundry apparatus;

FIG. 12 is a plane view illustrating the water supply and drainage device of the laundry apparatus;

FIG. 13 is an exploded perspective view illustrating a second tub of the laundry apparatus;

FIG. 14 is plane view illustrating the second tub of the laundry apparatus;

FIG. 15 is a sectional view illustrating the second tub and a second drum of the laundry apparatus;

FIG. 16 is partially sectional view illustrating the second tub and the second drum of the laundry apparatus;

FIG. 17 is a sectional view illustrating a heater sump of the laundry apparatus;

FIG. 18 is a sectional view illustrating an air chamber of the laundry apparatus;

FIG. 19 is a partially perspective view illustrating a second tub supporting device of the laundry apparatus;

FIG. 20 is a sectional view illustrating the second tub supporting device of the laundry apparatus;

FIGS. 21 and 22 are sectional view illustrating a connected portion of the second tub supporting device;

FIG. 23 is a partially perspective view illustrating another embodiment of the second tub supporting device;

FIG. 24 is a plane view illustrating a second tub supporting device of the second tub supporting device according to another embodiment;

FIG. 25 is a plane view illustrating an installation location of a drainage pump provided in the laundry apparatus;

FIG. 26 is a perspective view illustrating an installation state of the drawing pump;

FIG. 27 is an exploded perspective view illustrating the drainage pump of the laundry apparatus;

FIG. 28 is a sectional view illustrating the drawing pump of the laundry apparatus;

FIG. 29 is a perspective view illustrating a drainage chamber of the drainage pump provided in the laundry apparatus;

FIG. 30 is a side sectional view illustrating a fixing state of the second tub provided in the laundry apparatus;

FIG. 31 is a sectional view illustrating a second drum of the laundry apparatus;

FIG. 32 is a perspective view illustrating a side wall of the second drum provided in the laundry apparatus;

FIG. 33 is a plane view illustrating a base of the second drum provided in the laundry apparatus;

FIG. 34 is a side sectional view illustrating the base of the second drum; and

FIG. 35 is a conceptual diagram illustrating a drainage structure of the laundry apparatus.

#### DETAILED DESCRIPTION

Exemplary embodiments of the present invention will be explained in reference to the accompanying drawings.

Reference will now be made in detail to the specific embodiments of the present invention, examples of which are illustrated in the accompanying drawings. Wherever possible, the same reference numbers will be used throughout the drawings to refer to the same or like parts.

As shown in FIGS. 1 and 2, a laundry apparatus 1 includes a cabinet 1a configured to define a profile of the laundry apparatus 1. The cabinet 1a includes a first cabinet 10 where a first treating part 10a for treating laundry is formed and a second cabinet 20 where a second treating part 20a provided adjacent to the first cabinet 10 is formed to treat laundry.

In other words, a user loads laundry into the first cabinet 10 and/or the second cabinet 20 to perform washing, drying or refreshing. Here, the terminology 'refresh' may refer to a process of wrinkle removing, deodorizing, sanitizing, static electricity preventing or laundry warming, which uses air, heated air, steam, mist or water elements supplied to the laundry. In addition, clothes and laundry which will be mentioned in the present specification includes wearable

objects including clothes, apparel, shoes, socks, gloves and hats and all kinds of washable objects having a washing process performed thereto.

In the meanwhile, the first treating part 10a may include a first tub (not shown) and/or a first drum (not shown) provided therein to wash laundry, that is, to perform washing, drying or refreshing with respect to the laundry, as mentioned above.

The second treating part 20a may include a second tub (200, see FIG. 16) configured to hold wash water therein and a second drum (600, see FIG. 16). The second treating part 20a may be provided adjacent to the first treating part 10a and it may be provided in a predetermined portion near the first treating part 10a. For example, the second treating part 20a may be provided below the first treating part 10a.

When the second treating part 20a is provided together with the first treating part 10a for washing the laundry, the first treating part 10a and the second treating part 20a may have the same washing capacity.

However, considering limitation of an installation space for the laundry apparatus 1 and production cost of the laundry apparatus 1, either of the first and second treating parts 10a and 20a may have a smaller capacity than the other one.

As shown in drawings, this embodiment illustrates that at least one of a washing capacity, a volume, or a height of the second treating part 20a may be smaller than at least one of a washing capacity, a volume or a height of the first treating part 10a. Because of that, the user may select one of the first and second treating parts 10a and 20a properly according to the amount of the laundry.

Moreover, the user may select the first treating part 10a or the second treating part 20a according to the types of laundry items. For example, sensitive laundry items such as infant clothes and lingerie which have to be separately washed or a small amount of laundry items may be washed by using the second treating part 20a and the other types of the laundry items may be washed in the first treating part 10a.

When the second treating part 20a is configured to have a smaller washing capacity than the first treating part 10a, the second treating part 20a may be provided below the first treating part 10a. Since the height of the first treating part 10a is increased by the second part 20a provided below the first treating part 10a, the user may load or unload the laundry into or out of the first treating part 10a more smoothly and more efficiently.

Moreover, when the laundry apparatus 1 includes the first treating part 10a and the second treating part 20a, the first cabinet 10, where the first treating part 10a is installed, and the second cabinet 20, where the second treating part 20a is installed, may be manufactured independently and connected with each other.

However, considering manufacture efficiency, in other embodiments the first cabinet 10, having the first treating part 10a installed therein, may be integrally formed with the second cabinet 20, having the second treating part 20a installed therein, to be a single cabinet 1a. In other words, a single cabinet 1a is shared and the first and second treating parts 10a and 20a may be provided in the single cabinet 1a. In this case, a partition wall (not shown) may be provided between the first treating part 10a and the second treating part 20a to separate them from each other.

Here, an internal space of the cabinet 1a may be partitioned off into the first and second cabinets 10 and 20 by the partition wall mentioned above. In some embodiments, the partition wall may include a predetermined opening (not

shown) to allow the first treating part **10a** and the second treating part **20a** to communicate with each other.

In addition, configuration components provided in the second treating part **20a** may be extended to an inside of the first treating part **10a** via the opening. In other embodiments, configuration components provided in the first treating part **10a** may be extended to an inside of the second treating part **20a** via the opening.

As follows will be described an embodiment presenting that the first treating part **10a** and the second treating part **20a** are formed integrally as one body.

The first treating part **10a** may include a first door which can be opened selectively. The user can open the first door **15** to load the laundry into the first treating part **10a**.

A variety of components which will be described later may be provided in the second treating part **20a**. However, the components may have a structure with an easy access for users' convenience, maintenance and the like.

For example, as shown in the drawings, the second treating part **20a** may include a drawer **100** which can slide inward and outward. The drawer **100** is provided slidably such that the user may draw the drawer **100** forward to have an access to the inside of the second treating part **20a**.

As follows, the drawer of the second treating part according to the present invention will be described in detail in reference to the accompanying drawings.

In reference to FIGS. **2** and **3**, the drawer **100** may slide along an entry and exit space formed in the second cabinet **20** to open and close.

The laundry apparatus according to this embodiment includes a pair of side rail units **130** provided between the drawer **100** and the second cabinet **20** to guide the inward and outward movement of the drawer **100**. Especially, the laundry apparatus includes a lower rail unit **140** provided underneath the drawer **100**.

In the meanwhile, the side rail units **130** are provided between both side surfaces of the drawer **100**. The second cabinet **20** may limit upward and downward motion of the drawer **100** and may guide the inward and outward motion of the drawer **100**. The lower rail unit **140**, provided between a bottom surface of the drawer **100** and the second cabinet **20**, limits leftward and rightward motion of the drawer **100** and guides the inward and outward motion of the drawer **100**.

In reference to FIG. **4**, the drawer **100** is configured of a front portion **110**, forming a front surface of the drawer **100**, and a housing **120** where the second treating part **20a** will be installed. The front portion **110** is formed of a rectangular plate with a predetermined thickness and it is coupled to a front surface of the housing **120**. A handle **112** is formed in a front surface of the front portion **110** to allow the user to grasp, when the user is moving to open and close the drawer **100**.

As follows, the side rail units **130** installed between the housing **120** of the drawer **100** and the second cabinet **20** will be described in detail. Here, the side rail units **130** are symmetrically installed to both sides of the housing **120** in the same structure. Because of that, one of the rail units will be described first and description of the other rail unit will be omitted.

Side brackets **131** are provided in both sides of the housing **120**, to be coupled to the side rail units **130**, respectively. The side bracket **131** is formed of a bar having a predetermined length and it includes a front recess **132a** and a rear recess **133a** formed therein.

A front hooking member **132b** is formed in the front recess **132a** and a rear hooking member **133b** is formed in

the rear recess **133a**. The rear hooking member **133b** is bent in an 'L' shape and the front hooking member **132b** is formed straight.

The side rail unit **130** includes a moving rail **134** secured to the drawer **100**, a fixed rail **137** secured to an inner surface of a side panel **13** provided in the second cabinet **20** and a middle rail **138** secured between the moving rail **134** and the fixed rail **137**. A front coupling portion **135** and a rear coupling portion **136** are projected from a side of the moving rail **134**. Recesses or holes are formed in the front and rear coupling portions **135** and **136** to insert the front and rear hooking members **132b** and **133b** therein. It is preferable that the rear coupling portion **136** is coupled to the rear hooking member **133b** of the side bracket **132** and has a partially open top to prevent the inserted rear hooking member **133b** from being separated.

The moving rail **134** of the side rail unit **130** is secured to the side bracket **131** provided on the side of the housing **120**, the front hooking member **132b** and the rear hooking member **133b** of the side bracket **131** are inserted in the front and rear coupling portions **135** and **136** formed in the inner surface of the moving rail **134**, such that the drawer **100** may be secured to the moving rail **134**.

The fixed rail **137** of the side rail unit **130** is fixed to an inner surface of the side panel **13** provided in the second cabinet **20**. The fixed rail **137** may be fixed to the side panel **13** by a bolt or a screw. A location where the fixed rail **137** is secured is corresponding to a location where the moving rail **134** is secured. Here, the middle rail **138** is secured between the fixed rail **137** and the moving rail **134**.

The front hooking member **132b** is projected from a front portion of a lower surface of the side bracket **131** and the rear hooking member **133b** is projected from a rear portion thereof. A predetermined portion of the side bracket **131** may be cut out or bent to form the front and rear hooking members **132b** and **133b**.

In the meanwhile, the shapes of the front and rear hooking members **132b** and **133b** may be only an example and the present invention is not limited thereto. In other words, the front and rear hooking members **132b** and **133b** may be members used to secure the bracket to the moving rail and shapes of them may be varied properly.

A lower bracket **141** is provided in a bottom of the housing **120** to be secured to the lower rail unit **140**. Compared with the side rail unit **130**, the lower rail unit **140** has the same configuration, except a moving rail **144** having a different appearance. Front and rear coupling portions **145** and **146** are formed in an upper surface of the moving rail **144** to couple the lower bracket **141** thereto. The front and rear coupling portions **145** and **146** may be recesses or holes. The moving rail **144** of the lower rail unit **140** is secured to the lower bracket **141** provided in the bottom of the housing **120**. Front and rear hooking members **142** and **143** formed in the lower bracket **141** are inserted in the front and rear coupling portions **145** and **146** formed in the moving rail **144**, such that the drawer **100** may be secured to the moving rail **144**.

A fixed rail **147** of the lower rail unit **140** is fixed to an inner surface of a base (not shown) composing the second cabinet **20**. The fixed rail **147** may be fixed to the base by a bolt or a screw. A location where the fixed rail **147** is secured corresponds to a location where the moving rail **144** is secured. Together with that, a middle rail **148** is secured between the fixed rail **147** and the moving rail **144**.

Typically, the second treating part **20a** installed in the housing **120** is a top loading laundry device. The top loading laundry apparatus **100** includes a shaft **700** of a second drum



600 which is arranged perpendicular to the ground. When the second treating part 20a is put into operation, with the drawer 100 moved inwardly in the second cabinet 20, vibration would be generated in the second treating part 20a by the rotation of the second drum 600. Since the shaft 700 of the second drum 600 is arranged perpendicularly with respect to the ground, a lot of vibration might be generated in the drawer 100 including the second drum 600 in a direction parallel to the ground. Especially, this vibration is generated during a spinning cycle and more vibration is generated when the second drum 600 is eccentric.

When the side rail units 130 are secured to the drawer 100, the drawer 100 can move to a single degree of freedom along a forward and backward direction. In other words, vertical motion of the drawer 100 is limited by the securing of the moving rail 134, the middle rail 138 and the fixed rail 137 composing the side rail unit 130 and horizontal motion is also limited. However, the moving rail 134, the middle rail 138 and the fixed rail 137 composing the side rail unit 130 are secured to each other, spaced apart a predetermined distance from each other. Because of that, the drawer 100 can be moved along a leftward and rightward direction as much as the spaced distance and it might be vibrated in the leftward and rightward direction by the rotation of the second drum 600. The vibration is transferred to the laundry apparatus 1 including the first treating part 10a. As a result, durability of the laundry apparatus 1 will deteriorate and noise might be generated.

However, this embodiment of the present invention includes the lower rail unit 140, to limit the horizontal vibration of the drawer 100. In other words, the lower rail unit 140 not only guides the inner and outer motion of the drawer 100 but also limits the leftward and rightward vibration of the drawer 100. As a result, durability of the laundry apparatus 1 may be enhanced and noise may be reduced effectively.

The drawer 100 provided in the laundry apparatus according to this embodiment of the present invention may be completely separable from the second cabinet 20. In other words, when the second treating part 20a or the other parts located in the drawer 100 needs repairing, the drawer 100 can be detached from the second cabinet 20 to repair the second treating part 20a or the other parts smoothly and conveniently.

When the drawer 100 is detached, the drawer 100 is moved outward completely from the second cabinet 20. After that, the front portion of the drawer 100 is lifted a predetermined distance. At this time, the front hooking member 132b of the side bracket 131 is formed straight to be separated from the front coupling portion 135 of the moving rail 134 smoothly. However, the rear hooking member 133b is formed in the 'L' shape and it is not detached from the rear coupling portion 136, even the front portion 110 is lifted. The rear hooking member 133b may be sloping a predetermined angle along the direction in which the drawer 100 is lifted. At this time, when the drawer 100 is pulled along the sloping direction of the drawer 100, the rear hooking member 133b is detached from the rear coupling portion 136. Because of that, the drawer 100 is detached from the moving rail 134 to be completely detached from the second cabinet 20. Here, the front and rear hooking members 142 and 143 of the lower bracket 141 are formed straight. When the drawer 100 is lifted upwardly, the drawer 100 is detached from the moving rail 144 of the lower rail unit 140.

In the meanwhile, a locking assembly 116 and a locking securing part 12 are provided in the first cabinet 10 and the drawer 100 to limit the inner and outer motion of the drawer 100.

As shown in FIG. 2, the locking assembly 116 is provided in an upper portion of a rear surface of the front portion 110 to lock the drawer 100 when the drawer 100 is moved inwardly into the second cabinet 20 completely. Together with the locking assembly 116, the locking coupling portion 12 coupled to the locking assembly 116 is provided in a front panel 11 of the first cabinet 10. The locking coupling portion 12 is located opposite to the locking assembly 116.

The locking assembly 116 is coupled to the locking coupling part 12, to secure the drawer 100 not to move backward (that is, outward). The locking assembly 116 and the locking coupling portion 12 may be coupled to each other by hooking or any other suitable coupling method that is known to one of skill in the art.

When the drawer 100 is insertedly moved into the second cabinet 10 by the side rail units 130 and the lower rail unit 140, the side rail units 130 and the lower rail unit 140 reduce friction generated between the drawer 100 and the second cabinet 20. Because of that, when the drawer 100 is moved into the second cabinet 20, the drawer 100 may be easily accelerated by a little force applied thereto and it might collide with the second cabinet 20 by inertia.

This collision might apply a shock to the drawer 100 and the second treating part 20a, to damage to the components of the second treating part 20a. In addition, the shock might be transferred to the second cabinet 20, to damage the components of the first treating part 10a. As mentioned above, the shock generated in the drawer 100 and the second treating part happens to cause severe noise.

The laundry apparatus according to embodiments of the present invention include a shock preventing part 150 to solve that problem. The shock preventing part 150 is employed to relieve the shock generated by the collision of the drawer 100 against the second cabinet 20, when the drawer 100 is moved into the second cabinet 20.

In reference to FIGS. 2 and 7, the shock preventing part 150 is provided in the front of the cabinet 2 and it is formed in a trapezium shape, with a circular cross section. The shocking preventing part 150 may be any other suitable shape known to one of ordinary skill in the art. In some embodiments, two shock preventing parts 150 may be provided on both sides of the front portion of the second cabinet 20. In other embodiments, a total four shock preventing parts 150 may be attached or any other suitable number of shock preventing parts 150 known to one of skill in the art.

A bolt hole is formed in a center of the shock preventing part 150 and a bolt is inserted into the bolt hole to secure the shock preventing part 150 to the side of the front portion. It is preferable that the shock preventing part 150 is formed of an elastic material. In some embodiments, the shock preventing part 150 may be formed of rubber. In further embodiments, the shock preventing part 150 may be formed of an plastic or any other suitable elastic material known to one of skill in the art.

A receiving recess 114 is formed in the inner surface of the front portion 110 of the drawer 100 to receive the shock preventing part 150 therein. When the drawer 100 is moved into the second cabinet 20 completely, the front portion 110 of the drawer 100 may be designed to be spaced apart a predetermined distance from the side panel 13. The depth of the receiving recess 114 is smaller than the height of the shock preventing part 150 and it is preferable that the depth

of the receiving groove **114** is a half to two thirds with respect to the height of the shock preventing part **150**. Even if the shock preventing part **150** is pressed by collision with the drawer **100**, the front portion **110** of the drawer **100** may not collide with the side panel **13**.

Moreover, according to embodiments of the present invention, a rear lock **160** is further provided to secure the drawer **100** to prevent drawer **100** from sliding backwardly when moved into the second cabinet **20**.

In reference to FIGS. 7 to 9, the rear lock **160** is provided between a rear surface of the drawer **100** and a rear panel (not shown) of the second cabinet **20**. The rear lock **160** includes an engaging part **161** engaging with the housing **120** of the drawer **100** and a clamp **165** installed in the rear panel of the second cabinet **20**.

The engaging part **161** is configured of a support **162** having a bolt hole formed therein and a projection **163** coupled to the support **162**. The engaging part **161** is fixed to a rear surface of the housing **120** by a bolt. A cross section of the projection **163** is rectangular and the projection **163** is formed in a center of the support **162**. Arc-shaped engaging grooves **164** are formed in both sides of the projection **163**.

The clamp **165** receives and secures the engaging part **161** thereto, and it is configured of two ball housings **167** spaced apart a predetermined distance from each other and a support **166** secured to lower portions of the ball housings **167**. A bolt hole is formed in the support **166** and the clamp **165** is fixed to the rear panel by a bolt. A ball **168** is installed in the ball housing **167** and a hole is formed in the ball housing **167** to expose the ball **168** to the outside of the ball housing **167** partially there through. A diameter of the hole is smaller than a diameter of the ball **168** and a predetermined portion of the ball **168** is exposed via the hole. In addition, the ball **168** is supported by a spring **169** installed in the ball housing **167**. An end of the spring **169** is secured to the ball **168** and the other end of the spring **169** is secured to an inner surface of the ball housing **167**. The spring **169** is installed in a state of being compressed and the ball **168** is in close contact with the hole formed in the ball housing **167** by elasticity of the spring **169**.

According to an operational principle of the rear lock **160**, the projection **163** of the engaging part **161** is inserted between the ball housing **167** and the springs of the ball housing **167** are pressed accordingly. The elastic force which is strong in proportion to the pressed distances of the springs **169** is applied to the balls **168**. As illustrated in FIG. 9, a plurality of springs **169** are located in a pair of ball housings **167** and apply the elastic force to the balls **168** toward the projection **163** and the plurality of balls **168** apply a predetermined force along a direction toward a center of the projection **163** from both sides of the projection **163**. Because of that, the engaging part **161** is securely supported by the clamp **165**. Together with that, the drawer **100** having the engaging part **161** secured thereto is secured to the second cabinet **20** having the clamp **165** secured thereto. Here, the plurality of balls **168** are inserted in the grooves **164** formed in the projections **163** and they do not slip along a side surface of the projection **163** accordingly.

When the drawer **100** is kept in the second cabinet **20**, the drawer **100** may be secured between the locking assembly **116** provided in the front portion **110** of the drawer **100** and the locking securing part **12**. However, when laundry is treated in the second treating part **20a** installed in the drawer **100**, the second drum **600** of the second treating part **20a** rotates and vibration is generated accordingly. The vibration

cannot be eliminated by the locking assembly **116** enough, resulting in vibration generated in the entire portion of the laundry apparatus.

The laundry apparatus **1** according to embodiments of the present invention may include the rear lock **160** provided in the drawer **100** to secure the drawer **100** stably and to restrain vibration. In addition, it is preferable that the rear lock **160** is installed in a rear portion of the rear surface of the drawer **100**. Typically, the locking assembly **116** is arranged in the upper portion of the front portion **110** of the drawer **100**. The rear lock **160** is installed in the lower portion of the rear surface of the drawer **100**. The securing means of the drawer **100** may be arranged in symmetry in some embodiments. In other words, the locking assembly **116** and the rear lock **160** are arranged symmetrically, to secure the drawer **100** more stably.

As a result, the laundry apparatus according to embodiments of the present invention may include the rail provided in the bottom of the drawer to remove sideward-vibration generated when the auxiliary laundry device is put into operation. Because of that, durability of the laundry apparatus is enhanced and noise is effectively restrained.

Furthermore, the collision between the drawer and the cabinet which is generated by the inertia of the drawer motion when the drawer is moved into the cabinet may be prevented effectively.

Meanwhile, there may be several disadvantages when the drawer **100** is used to lead in and out the second treating part **20a**. The second treating part **20a** requires a water supply pipe to supply water to the second tub **200** and a drainage pipe to drain the wash water.

When the drawer **100** is led out, the second tub of the second treating part **20a** is led out together with the drawer **100**. At this time, the water supply pipe and the drainage pipe which are connected with the second tub **200** have to be extended. Therefore it may be necessary to provide a configuration used to extended or reduce the water supply pipe and the drainage pipe based on the leading-in and leading-out of the drawer **100**. If the water supply pipe and the drainage pipe are not arranged effectively, the water supply pipe and the drainage pipe might be caught by the rear surface of the drawer **100** in the inward motion of the drawer **100**. In addition, the water supply pipe and the drainage pipe might be torn or damaged by the drawer.

Because of the problem, the laundry apparatus **1** includes a water supply/drainage device **400** which is provided in a rear portion of the drawer **100** flexibly.

In reference to FIG. 10, the water supply/drainage device **400** includes a first link **420** and a second link **430** arranged below the first link **420**. The first link **420** and the second link **430** are rotatably coupled to each other by a hinge. It is preferable that the first link **420** is provided beyond the second link **430**.

Together with that, it is preferable that long axes of the first and second links **420** and **430** are arranged in parallel to a width direction of the second cabinet **20**. In other words, the width of the second cabinet **20** having the drawer **100** provided therein is structurally longer than the height of the second cabinet **20**. Because of that, the long axes of the first and second links **420** and **430** are arranged in parallel to the width direction of the second cabinet **20** and the first and second links **420** and **430** arranged vertically have an advantage in an aspect of space utilization.

The first link **420** and the second links **430** are symmetrical in a profile and a configuration. As follows, the same configuration elements of the second link **430** as those of the first link **420** will be omitted.

## 11

The first link 420 forms an internal space, with both open sides. A flexible water supply pipe 450 and a flexible drainage pipe 460 are insertedly installed in the both open sides of the first link 420. In other words, the flexible water supply pipe 450 and the flexible drainage pipe 460 are provided in the internal space of the first link 420.

An end of the first link 420 is connected to a rear panel (not shown) of the second cabinet 20 and the first link 420 is rotatably connected to the rear panel of the second cabinet 20. More specifically, the end of the first link 420 is hingedly connected with a first bracket 422 and the first bracket 422 is fixedly connected with the rear panel.

The second link 430 is connected with the lower portion of the first link 420. The profile and configuration of the second link 430 is identical to those of the first link 420, except an end of the second link 430 which is hingedly connected with the rear surface of the housing 120 provided in the drawer 100. More specifically, the end of the second link 430 is hingedly connected with a second bracket 432 and the second bracket 432 is fixedly connected with the rear surface of the housing 120. Together with that, the other end of the second link 430 is hingedly connected with the first link 420.

A hinge connecting part 470 is formed between the first link 420 and the second link 430 and a hinge shaft (not shown) is inserted in the hinge connecting part 470. The hinge connecting part 470 may be a projection. The hinge connection part 470 may be configured of a first projection 424 formed in a bottom of the first link 420 and a second projection 434 formed in a top of the second link 430. The first projection 424 and the second projection 434 may be integrally formed with the first link 420 and the second link 430, respectively.

A water supply hole 410 is provided in a rear upper portion of the second cabinet 20 and the water supply hole 410 is configured of a hot water supply hole 412 for supplying hot water and a cold water supply hole 414 for supply cold water. The water supply hole 410 is in communication with the flexible water supply pipe 450. The flexible water supply pipe 450 is branched to be two pipes. One of the branched pipes is connected with the hot water supply hole 412 and the other one is connected with the cold water supply hole 414. The flexible water supply pipe 450 is inserted in the first and second links 420 and 430. The flexible water supply pipe 450 may be arranged in a “C” shape entirely. In other words, the flexible water supply pipe 450 may be inserted in the end of the first link 420 and exhausted from the other end. The flexible water supply pipe 450 exhausted from the other end of the first link 420 is inserted in an end of the second link 430 to be exhausted from the other end of the second link 430. The flexible water supply pipe 450 exhausted from the other end of the second link 430 may be connected with the second treating part 20a, passing through the rear surface of the housing 120.

The flexible drainage pipe 460 is installed in the same way as the flexible water supply pipe 450. In other words, the flexible drainage pipe 460 may be arranged in the first and second links 420 and 430 in a “C” shape. An end of the flexible drainage pipe 460 is exhausted to a rear portion of the second cabinet 20. In other words, a drainage portion of the flexible drainage pipe 460 configured to exhaust wash water outside is located in an outside of the second cabinet 20. It is preferable that a through hole (not shown) is formed in the rear panel of the second cabinet 20 to exhaust the flexible drainage pipe 460 there through.

It is preferable that the flexible water supply pipe 450 and the flexible drainage pipe 460 are formed of a flexible

## 12

material which can be flexed according to the rotation of the first and second links 420 and 430.

Although not shown in the drawings, the first and second links 420 and 430 may guide a control line (not shown) and the control line includes an electricity line or a control line.

Moreover, it is described above that the end of the first link 420 located upper is connected with the rear panel and that the end of the second link 430 located lower is connected with the rear surface of the housing 120. Alternatively, the end of the first link 420 located upper is connected with the rear surface of the housing 120 and the end of the second link 430 located lower is connected with the rear panel.

As follows, an operational state of the water supply/drainage device 400 mentioned above will be described.

FIG. 10 is a rear view illustrating the drawer 100 which is moved into the second cabinet 20 completely and FIGS. 11 and 12 are side sectional and plane views illustrating the drawer 100 which is moved outward completely from the second cabinet 20.

In reference to FIG. 10, the first link 420 and the second link 430 are folded to be arranged on the same perpendicular plane. In other words, the first link 420 and the second link 430 are arranged in parallel to the rear surface of the housing 120. Together with that, the flexible water supply pipe 450 and the flexible drainage pipe 460 are bent in a “C” shape near the hinge-connecting portion of the first and second links 420 and 430. In other words, the flexible water supply pipe 450 and the flexible drainage pipe 460 exhausted from the first end of the first link 420 are bent gently to be inserted in the end of the second link 430.

In reference to FIG. 11, when the drawer 100 is led out, the first and second links 420 and 430 connected to the drawer 100 are not located on the same perpendicular plane anymore. In other words, the first link 420 is rotated about the connected portion with the rear panel of the second cabinet 20 and the second link 430 is rotated about the connected portion with the housing 120. Here, the second link 430 is rotated about all of the connected portions with the housing 120 and with the first link 420. In contrast, the first link 420 is only rotated about the connected portion with the rear panel.

In reference to FIG. 12, when the drawer 100 is led out completely, the first and second links 420 and 430 are located on the same perpendicular plane again. However, the second link 430 is not located underneath the first link 420 but at a diagonal angle with respect to the first link 420. It is preferable that the first and second links 420 and 430 maintain a predetermined angle, not located on the same perpendicular plane completely, when the drawer 100 is moved outward completely. In other words, if the first and second links 420 and 430 are placed on the same perpendicular plane in the state of the drawer 100 being led out completely, the first and second links 420 and 430 might not be rotated relatively when the drawer is led in again. In other words, if the first and second links 420 and 430 are located on the same perpendicular plane, a moment for rotating the first and second links 420 and 430 cannot be formed. Because of that, if the first and second links 420 and 430 maintain a predetermined angle when the drawer 100 is led out completely, the first and second links 420 and 430 may be rotated smoothly when leading in the drawer 100.

As a result, the water supply pipe 450 and the drainage pipe 460 of the auxiliary laundry device may be arranged effectively by the hinge assembly configured of the pair of the links. Twist or damage of the water supply pipe and the

drainage pipe generated when leading in or out the drawer may be prevented accordingly.

When the second treating part **20a** is formed in the drawer **100** as described above, the auxiliary laundry device may be a top loading type which allows the user to load laundry via a top thereof vertically. Because of that, the user may load or unload the laundry into or out of the drum **600** smoothly and conveniently after leading out the drawer **100**.

As follows, the second tub and the second drum according to embodiments of the present invention will be described in detail in reference to the accompanying drawings.

In reference to FIGS. **13** and **14**, the second treating part **20a** includes a second tub **200**, a second drum **600** rotatably mounted in the second tub **200**, a tub cover **210** coupled to a top surface of the second tub **200**, a cover **214** coupled to the tub cover **210**, a water chamber **217** and a water supply hose **219a** configured to supply wash water to the second drum **600**, and a water chamber cover **219** configured to cover the water chamber **217**. The water chamber **217** is configured to reduce the speed of the wash water, which will be described in detail later.

The second tub **200** and the second drum **600** have open tops. The second tub **200** surrounds the second drum **600** and it prevents the wash water from leaking outside. The second drum **600** is rotatable within the second tub **200**. The second drum **600** holds laundry and it is provided with the wash water. A plurality of ribs may be projected from an outer circumferential surface of the second tub **200** to reinforce the strength of the second tub **200**.

The tub cover **210** prevents the wash water and the laundry from being thrown outside during the washing, and it is coupled to a top surface of the second tub **200**. A semicircular-shaped opening **211** is formed in an inner circumference of the tub cover **210** and the opening **211** is an introduction space for the laundry to be loaded or unloaded. The opening **211** is opened and closed by the cover **214**. The cover **214** is hingedly coupled to the tub cover **210** and the cover **214** is configured of a frame **215** and a transparent window **216** secured in the frame **215**. A handle **215a** used to open and close the cover **214** is provided in a center of the frame **215**. The transparent window **216** is formed of a transparent material and it allows the user to identify the state of the laundry and wash water inside the second drum **600**. The user opens the cover **214** before starting the washing process and he or she loads the laundry into the second drum **600**. After the washing process, the user opens the cover **214** and he or she takes out the laundry from the second drum **600**. During the washing process, the cover **214** is kept being closed.

A chamber support **212** is formed in a rear portion of the semicircular opening **211** formed in the tub cover **210** and the water chamber **217** is installed in the chamber support **212**. A hinge is provided in the chamber support **212** to connect the cover **214** to the second cover.

The water chamber **217** is a device configured to supply the wash water to the second drum **600** and it is located in the center of the chamber support **212**, adjacent to the opening **211**. Here, the water chamber **217** communicates with an end of the water supply hose **219a**. The water supply hose **219a** is inserted in a predetermined portion of the tub cover **210** and it is arranged along an inner surface of the tub cover **210**, that is, an outer surface of the chamber support **212**. Together with that, the water supply hose **219a** is bent at a center of the outer surface of the chamber support **212** to communicate with the water chamber **217**. The other end of the water supply hose **219a** is in communication with the flexible water supply pipe **450**.

The water chamber cover **219** is coupled to the chamber support and the water chamber cover **219** is coupled with the chamber support **212**, to form a predetermined internal space where the water chamber **217** is installed.

In the meanwhile, fixers **218** for fixing the water chamber **217** are formed around the water chamber **217** and bolt grooves are formed in the fixers **218** to couple the water chamber cover **219** to the chamber support **212**. The fixers **218** may be integrally formed with the water chamber cover **219**.

A cross section of the water chamber **217** is larger than a cross section of the water supply hose **219a**. As the wash water is moving at a high speed via the water supply hose **219a**, the speed of the wash water is decreased drastically at the water chamber **217**. Because of that, the wash water may be supplied to the second drum **600** not at a high speed but at a relatively low speed.

According to the conventional laundry device, wash water is supplied to a drum from a predetermined portion of the second tub **200** or of the tub cover **210**. Typically, most of the laundry is located in a center of the second drum **600** and the conventional laundry apparatus consumes quite a lot of time to dampen the laundry. However, according to an embodiment of the present invention, the water chamber **217** for supplying the wash water is arranged near the center of the second drum **600**, to supply the wash water to the center of the second drum **600**. Because of that, the time required for the wash water to dampen the laundry may be reduced effectively.

In the meanwhile, the opening **211** is approximately semicircular and the angle at the circumference is over 180 degrees, exactly. In other words, the opening **211** formed in the tub cover **210** may be larger than the space occupied by the chamber support **212**. Because of that, the space for loading and unloading the laundry may be secured as much as possible.

As a result, the water chamber is arranged in the center of the drum according to the present invention to supply the wash water to the center of the drum, such that the laundry may be dampened more quickly.

In the meanwhile, as shown in FIG. **15**, a shaft **700** passing through the second tub **200** is provided in a lower portion of the second tub **200**. An upper end of the shaft **700** is connected with the drum **600** mounted in the second tub **200** such that the second drum **600** may be rotated along the rotation of the shaft **700**. A motor **800** is installed underneath the second tub **200** to rotate the shaft **700**.

Within the drawer **100**, the second tub **200** is elastically supported by an auxiliary supporting device (**500**, see FIG. **19**), which will be described later. Vibration generated by the rotation of the second drum **600** to be transferred to the second tub **200** may be suspended and reduced by the supporting device **500**.

A through hole **222** to pass the shaft **700** there through may be formed in the center of the second tub **200**. In addition, a bearing housing **250** configured to support the shaft **700** is inserted in a bottom of the second tub **200**. Preferably, the bearing housing **250** is integrally formed with the second tub **200** when the second tub **200** is molded. Here, when the second tub **200** is formed according to injection molding, the bearing housing **250** may be insert-molded when the second tub **200** is injection-molded. Here, shaft holes **252** to pass the shaft **700** there through are formed in a center of the bearing housing **250** and a pair of bearings **254** to rotatably support the shaft **700** are inserted in the shaft holes **252**. A water seal **256** is provided in the shaft hole **252** of the bearing housing **250** to maintain air

## 15

tightness between the shaft **700** and the second tub **200**, in contact with the shaft **700**. The water seal **256** is formed in a ring shape, fixed to an inner circumferential surface of the bearing housing **250**, and a sealing rib **258** is projected from an inner circumferential surface of the water seal **256** to maintain the air tightness.

The motor **800** is installed underneath the second tub **200** and it rotates the shaft **700** supported by the bearing housing **250**. Here, the motor **800** may be an outer rotor type motor including a stator fixed to an outer circumferential surface of the shaft of the second tub **200** and a rotor fixed to the shaft, surrounding the stator.

As shown in FIGS. **16** to **18**, a heater sump **230** may be formed in an inner lower surface of the second tub **200**. A heater **231** is installed in the heater sump **230** to heat the wash water held in the second tub **200**. A drainage part **235** is provided in the heater sump **230** to drain the wash water held in the second tub **200** and an air chamber **237** is installed in the drainage part **235** to sense the amount of the wash water held in the second tub **200**.

Here, in reference to FIGS. **16** and **17**, a sloping surface **238** is formed in the bottom of the second tub **200** to allow the wash water of the second tub **200** to be collected in the heater sump **230**. In other words, when the wash water held in the second tub **20** is drained, the sloping surface **238** formed in the bottom of the second tub **200** helps the wash water collect in the heater sump **230** to be drained via the heater sump **230**.

When the wash water held in the second tub **200** is heated, the sloping surface **238** collects the wash water in the heater sump **230** to be heated. In this case, even if the wash water is insufficient when heating the wash water, the wash water is collected in the heater sump **230** by the sloping surface **130**. Because of that, overheating of the heater **231** and damage to the heater **231** may be prevented.

The heater sump **230** mentioned above cannot be formed at the relatively least space formed by the second tub **200** installed in the limited space of the drawer **100**. In other words, only the least space having the heater **231** formed therein is used to form the heater sump **230**.

In this case, the installation of the heater **231** itself may be a problem. The heater **231** includes a heater terminal **232** connected with the power source and a heating road **233**. Simultaneously, the heater terminal **232** fixes the heater **231**. Because of that, the size of the heater terminal **232** is relatively larger than the size of the heating road **233**. Typically, the heater terminal **232** is bent along a perpendicular direction with respect to the heating road **233** for installation efficiency. However, according to the present invention, the heater terminal **232** is formed in the same direction as the heating road **233** because of the small space. As a result, even when the heater sump **230** is projected toward the lower portion of the second tub **200**, the heater terminal **232** of the heater **231** is caught by the rib for reinforcing the strength of the second tub **200** when the motor **231** is installed and it interferes with the inserting path of the heater **232**, which makes it difficult to install the heater **231**.

Because of that, when the motor **231** is installed, the installation direction of the heater **231** is sloping from a lower portion of the heater sump **230** toward an upper portion. In other words, when the heater **231** is inserted, the heater **231** is inserted in the heater sump **230** with an end of the heating road **233** being upward and the heater terminal **232** being downward. After the heating road **233** is inserted completely, the heating road **233** is rotated horizontally to fix the heater terminal **232** to the heater sump **230**.

## 16

Meanwhile, an auxiliary heater clamp **234** for fixing the heating road **233** of the inserted heater **231** may be installed in an inner surface of the heater sump **230**. The heater clamp **234** supports the heater in a rightward and leftward direction.

Such the heater clamp **234** and the second tub **200** are manufactured independently and the heater clamp **234** is inserted in the heater sump **230** in advance before the heater **231** is installed. The heater clamp **234** is located in a predetermined position opposed to the inserting direction of the heater **231** and it fixes an end of the heating road of the heater **231**. Here, the heater clamp **234** is inserted in the installation hole provided in the heater sump **230** by a predetermined elasticity and a hooking projection is projected in the end of the heater sump **230** to prevent the separation of the heater sump **230**.

Additionally, because of the limited small space of the heater **231**, the direction of the heater terminal **232** is identical to the direction of the heating road **233** to connect the power terminal (not shown) to the heater terminal **232**.

In other words, when the direction of the heater terminal **232** is perpendicular to the direction of the heating road **233**, like the conventional heater, the space formed between the second tub **200** and the drawer **100** is narrow and it is difficult to connect the power terminal with the heater terminal.

However, when the direction of the heater terminal **232** is identical to the direction of the heating road **233**, the power terminal is inserted along the installation direction of the heater **231**, to be connected with the heater terminal **232** smoothly.

As shown in FIG. **18**, the drainage part **235** is provided in a bottom of the heater sump **230** to drain the wash water held in the second tub **200** such the drainage part **235** is connected with a drainage device (not shown) and the wash water collected in the heater sump **230** is drained by a drainage pump (**300**, see FIG. **26**) provided in the drainage device. The drainage pump **300** will be described in detail later.

Here, a branched pipe **236** branched toward an upper portion of the drainage part **235** is formed in the drainage part **235** and a pressure water level sensor (not shown, for example, a diaphragm pressure sensor) is connected with the branched pipe **236** to sense a water level of the wash water stored in the second tub **200**. The air chamber **237** is provided between the branched pipe **236** and the pressure water level sensor. The air chamber **237** allows the pressure water level sensor to detect pressure changes of the branched pipe **236** by using a volume.

Meanwhile, the conventional laundry apparatus includes a suspension system which supports the drum and the tub and which reduces vibration generated by the rotation of the drum, such as a cylinder and a piston or a spring and a damper. Such a conventional suspension system is flexible according to the weights of the drum and the tub, to support the drum and the tub. Because of that, the drum and the tub may move downwardly a predetermined distance or more.

As a result, it is limited to install and drive the conventional suspension system in the narrow space of the second cabinet **20**. As follows will be described a supporting device which is provided in the second cabinet **20** of the laundry apparatus **1** according to the above embodiments, to support the second drum **600** and the second tub **200** and to suspend the vibration generated by the rotation of the second drum **600** to limit the movement of the second drum **600** and the second tub **200**.

In reference to FIGS. 19 and 20, a supporting device 500 according to an embodiment may maintain the distance between the second tub 200 and the second cabinet 20 in a predetermined range. In other words, the supporting device 500 may prevent the second tub 200 and the second cabinet 20 from being spaced apart over the predetermined range or from being too closed over the range.

Here, when the drawer 100 is provided in the second cabinet 20 as mentioned above, the supporting device 500 is provided between the second tub 200 and the drawer 100 and it can maintain the distance between the drawer 100 and the second tub 200 in a predetermined range. In other words, according to an embodiment not including the drawer 100, the supporting device 500 may be provided between the second tub 200 and the second cabinet 20. According to an embodiment including the drawer 100, the supporting device 500 may be provided between the second tub 200 and the drawer 100. The embodiment including the drawer 100 provided in the second cabinet and the supporting device 500 provided between the second tub 200 and the drawer 100 will be described.

As a result, the supporting device according to this embodiment limits the movement of the second tub 200 and it can suspend horizontal vibration and/or vertical vibration which are generated by the rotation of the second drum 600. More specifically, the supporting device 500 may be provided between a first fixing part 510 provided in the drawer 100 and the sloping surface 240 provided in the second tub 200. In this case, the supporting device 500 may maintain the distance between the first fixing part 510 and the sloping surface 240 in a predetermined range. As follows, a specific configuration of the supporting device 500 will be described in reference to the drawings.

The supporting device 500 according to an embodiment includes a first supporting part 520 configured to limit downward movement and horizontal movement of the second tub 200 and a second supporting part 530 configured to limit upward movement of the second tub 200. The supporting device 500 according to the embodiment may include a supporting part configured to limit movement of the second tub according to vibration of the second tub generated by the rotation of the second drum 600, that is, a direction of movement of the second tub 200. Here, the first supporting part 520 may limit downward movement and leftward-and-rightward movement of the second tub 200. The second supporting part 530 may limit upward movement of the second tub 200.

In the meanwhile, the second drum 600 and the second tub 200 may be vibrated along various directions by the rotation of the second drum 600. For example, they may be vibrated along a vertical direction or a horizontal direction. Even when they are vibrated along the vertical direction, the second drum 600 and the second tub 200 may be vibrated linearly or curvedly, and vice versa when they are vibrated along the horizontal direction. By extension, when the second tub 200 and the second drum 600 are rotated, only a single direction rotation will occur rarely and vibration having complex directional elements will usually be generated. For example, they are vibrated vertically and vibrated horizontally along a curvature at the same time.

When limiting the downward and horizontal movement of the second tub 200, the first supporting part 520 can limit the upward movement of the second tub 200 simultaneously. Here, the first supporting part 520 can limit the downward and horizontal vibration of the second tub 200 mainly, with limiting the upward movement of the second tub 200 additionally. This can be applied to the second supporting

part 530. In other words, the second supporting part 520 can limit the upward movement of the second tub 200 mainly, with limiting the downward and/or horizontal movement of the second tub 200 additionally.

The first and second supporting parts 520 and 530 mentioned above may be provided between the second tub 200 and the drawer 100. For example, the first and second supporting parts 520 and 530 may be provided between the first fixing part 510 provided in the side wall of the second tub 200 and the sloping surface 240 provided in the inner wall of the drawer 100. The first fixing part 510 may be integrally formed with the side wall of the second tub 200 and the sloping surface 240 may be integrally formed with the inner wall of the drawer 100.

In the meanwhile, to provide the first and second supporting parts 520 and 530 between the first fixing part 510 and the sloping surface 240, the first fixing part 510 may face the sloping surface 240 in opposite. Furthermore, they may face each other in opposite along a perpendicular direction. The first and second supporting parts 520 and 530 may be provided along a perpendicular direction accordingly.

For example, as shown in FIG. 19, the first fixing part 510 is provided in an upper portion of the supporting device 500 and the sloping surface 240 is provided lower than the first fixing part 510, such that they are opposing each other along a perpendicular direction. The first fixing part 510 may be extended outwardly from the side wall of the second tub 200 and the sloping surface 240 may be extended toward the second tub 200 from the inner wall of the drawer 100.

Here, the first supporting part 520 may include a supporting bar 522 configured to limit the moving distance of the second tub 200 according to a moving direction and a connecting portion 526. In other words, the supporting bar 522 is configured to limit the downward movement of the second tub 200 and the connecting portion 526 is configured to limit the rightward and leftward movement of the second tub 200.

Specifically, the supporting bar is substantially formed of a rigid material and both ends of the supporting bar 522 may be connected with the first fixing part 510 and the sloping surface 240, respectively. First and second inserting portions 512 and 242 may be provided in the first fixing part 510 and the sloping surface 240, respectively, to connect the ends of the supporting bar 522 there with. Because of that, the ends of the supporting bar 522 may be connected with the first fixing part 510 and the sloping surface 240, passing through the first and second inserting portions 512 and 242. In addition, a separation preventing portions 524 may be provided in the ends of the supporting parts to prevent the ends from separating from the first fixing part 510 and the sloping surface 240. Here, the connecting portions 526 may be provided between the separation preventing portion 524 and the first fixing part 510 and between the separation preventing portion 524 and the sloping surface 240, respectively.

According to this embodiment, the first fixing part 510 and the sloping surface 240 may be opposite to each other along a perpendicular direction and the supporting bar 522 provided between them may be provided along a perpendicular direction. Because of that, when the laundry is accommodated in the second drum 600 and the wash water is held in the second tub 200, a predetermined tension may be applied to the supporting bar 522 by the loads of the second drum 600 and the second tub 200.

Meanwhile, the supporting bar 522 may be substantially formed of a rigid body and both ends of the supporting bar 522 may be prevented from being separated from the first fixing part 510 and the sloping surface 240. Even when the

tension is applied to the supporting bar 522 along the perpendicular direction by the loads of the second drum 600 and the second tub 200, the supporting bar 52 may stop the second tub 200 from moving downwardly as far as the length of the supporting bar 522, or farther than the length. In other words, even if the second tub 200 is moved downwardly by the rotation or vibration of the second drum 600, the downward movement of the second tub 200 may be limited by the supporting bar 522.

In the meanwhile, the upward movement of the second tub 200 generated by the rotation or vibration of the second drum 600 may be limited by the second supporting part 530. Here, the second supporting part 530 may be provided between the first fixing part 510 and the sloping surface 240 and it may be formed of an elastic member capable of providing an elastic force to both ends thereof. In other words, the second supporting part 530 may be compressed between the first fixing part 510 and the sloping surface 240 and it supplies the elastic force to the ends thereof, that is, to the first fixing part 510 and the sloping surface 240. As a result, the upward movement of the second tub 200 may be limited by the elastic force of the second supporting part 530. In addition, the separation preventing portions 524 provided at the ends of the supporting bar 522 may be in close contact with the connecting portion 526 by the elastic force of the second supporting part 530, such that the connecting portions 526 may be in close contact with the first fixing part 510 and the sloping surface 240. Because of that, the distance between the first fixing part 510 and the sloping surface 240 may be maintained in the predetermined range by the supporting bar 522 and the elastic material 540, only to limit the vertical movement of the second tub 200. When the second supporting part 530 is provided between the first fixing part 510 and the sloping surface 240, the second supporting part 530 may be provided along an outer circumference of the supporting bar 522.

Moreover, the horizontal movement of the second tub 200 generated by the rotation of the second drum 600 may be limited by the connecting portion 526 of the first supporting part 520 mentioned above. Here, the connecting portions 526 may be provided in both ends of the supporting bar 522 and they may limit the horizontal movement of the second tub 200 by using a frictional force with the fixing part 510 and the sloping surface 240. For example, the second tub 200 is vibrated to receive a predetermined force for moving horizontally. If then, the supporting bar 522 may receive a moment to be rotated between the first fixing part 510 and the sloping surface 240. In this case, if the supporting bar 522 is not configured to be rotated at all, the moment applies a tension to the supporting bar 522 and damage to the supporting bar 522 might occur.

Because of that, the supporting bar 522 may be configured to be rotatable to a predetermined angle with respect to the first fixing part 510 and the sloping surface 240. In this case, the rotation of the supporting bar 522 may be limited by the connecting portions provided at the ends of the supporting bar 522 and the frictional force between the first fixing part 510 and the sloping surface 240. As a result, the horizontal movement of the second tub 200 may be prevented.

The configuration of the rotatable supporting bar 522 will be specifically described as follows. First and second seating portions 244 and 514 may be provided in the first fixing part 510 and the sloping surface 240 to seat at least a predetermined portion of the connecting portions thereon. The connecting portion 526 may have a semicircular, circular or curved shape and the first and second seating portions 244 and 514 may have corresponding shapes with respect to the

connecting portions 526, respectively. As a result, the shape of the connecting portions 526 provided at the ends of the supporting bar 522 and the shapes of the first and second seating parts 244 and 514 enable the supporting bar 522 to perform the rotation to a predetermined angle. The frictional force generated between contacting surfaces may be calculated according to a following mathematical equation:

$$F = \mu N \quad \text{[Mathematical Equation]}$$

Here, 'μ' refers to a frictional coefficient and 'N' refers to a normal force. To increase the frictional force between the connecting portions 526 and the first fixing part 510 and the sloping surface 240, specifically, the frictional force between the connecting portion 526 and the first fixing part 510 and between the connecting portion 526 and the sloping surface 240, the connecting portions 526 and the first and second seating portions 244 and 514 may be formed of a material having a high frictional coefficient. To increase the normal force, the connecting portions 526 and the first and second seating portions 244 and 514 are contacting with each other as closely as possible.

According to the supporting device 500 of this embodiment, surfaces of the connecting portions 526 and/or surfaces of the first and second seating portions 244 and 514 provided in the sloping surface 240 and the first fixing part 510 may be formed of a material having a high frictional coefficient. According to this embodiment, to increase the normal force, the connecting portions 526 and the first and second seating portions 244 and 514 may contact with each other as closely as possible and at least one of the connecting portions 526 or the first and second seating portions 244 and 514 may include an elastic member to prevent any gap from being generated between them. In other words, the elastic force of the second supporting part 530 mentioned above enables the first fixing part 510 and the sloping surface 240 to be in close contact with the connecting portions 526, and the elastic member enables the connecting portions 526 and the first and second seating portions 244 and 514 to contact with each other as closely as possible, to increase the normal force.

FIGS. 21 and 22 are diagrams schematically illustrating a connecting member including the elastic member.

The elastic member 540 may be exposed along an outer circumference of the connecting portion 526 as shown in FIG. 21 or at least a predetermined portion of the elastic member 540 may be embedded in the connecting portion 526 as shown in FIG. 22. When the elastic member 540 is embedded in the connecting portion 526, it is preferable that the elastic member 540 is not embedded in the connecting portion 526 more than a predetermined depth, to allow the connecting portion 526 to be in contact with the first and second seating portions 244 and 514 closely by the elastic force thereof.

When the horizontal vibration of the second tub 200 is generated by the rotation of the second drum 200, the second tub 200 happens to contact with the supporting device 500, to generate interference with each other. Especially, according to the above embodiments of the laundry apparatus, the second cabinet 20 has a relatively narrow internal space and the distance between the second tub 200 and the drawer 100 could be relatively narrow, compared with the conventional laundry apparatus. Because of that, the supporting device 500 provided between the second tub 200 and the drawer 100 may be provided adjacent to the second tub 200 closely. If the interference is generated between the second tub 200 and the supporting device 500 by the horizontal vibration of the second tub 200, there might be damage to an outer wall

## 21

of the second tub **200** and damage to the supporting device **500**. Because of that, the supporting device **500** cannot function well and noise and vibration of the laundry apparatus **1** might then increase. As follows will be described a configuration used to prevent the interference between the second tub **200** and the supporting device **500** even if vibration is generated in the second tub **200**.

In reference to FIG. **23**, a laundry apparatus **1** according to another embodiment may include a damping material **280** configured to maintain a predetermined distance or more between the supporting device **500** and the second tub **200** to prevent interference generated between them. The damping material **280** may have a predetermined elastic force and it is provided between the supporting device **500** and the second tub **200**, to prevent the interference between the second tub **200** and the supporting device **500** even if the second tub **200** is vibrated. The damping material **280** may be provided in at least one of the supporting device **500** and the second tub **200**, for example, it may be provided along an outer circumference of the second tub **200** as shown in FIG. **23**.

Meanwhile, the supporting device **500** provided in the laundry apparatus **1** according to some embodiments damps the vibration of the second tub **200**. However, in case of damping the vertical and/or horizontal vibration of the second tub **200**, the supporting device **500** may be provided along at least three portions or more along the outer circumference of the second tub **200**. When the plurality of the supporting devices **500** are provided at two portions along the outer circumference of the second tub **200**, a yawing phenomenon might be generated with respect to the supporting device **500**.

FIG. **24** is a plane view of the drawer **100** when the drawer **100** is provided in the second cabinet **20**. FIG. **24** illustrates three supporting devices **500** provided in the laundry apparatus along the outer circumference of the second tub **200**.

In reference to FIG. **24**, the supporting device **500** according to this embodiment includes a first supporting device **500a** provided in a front surface of the second tub **200** and second and third supporting devices **500b** and **500c** provided to form the same angle with the first supporting device **500a**. For example, the second and third supporting devices **500b** and **500c** may be located approximately adjacent to rear corners of the drawer **100**. An angle formed between the first supporting device **500a** and the second supporting device **500b** and an angle formed between the first supporting device **500a** and the third supporting device **500c** may be approximately  $120^{\circ}$ ~ $60^{\circ}$ . An angle formed between the second supporting device **500b** and the third supporting device **500c** may be approximately  $120^{\circ}$ ~ $60^{\circ}$ .

As mentioned above, the laundry apparatus **1** according to the present invention includes the supporting device **500** configured to prevent the vibration of the second tub **200**, to reduce noise and vibration generated therein.

When the second cabinet **20** is provided, the laundry apparatus **1** according to the present invention may include the supporting device **500** which can be installed in the narrow internal space of the second cabinet **20** smoothly.

Meanwhile, it is necessary to provide a drainage pump **300** provided in the second tub **200** of the second treating part **20a** to drain the wash water having treated the laundry. The wash water drained from the second treating part **20a** is drained via a second drainage pipe **480** and an auxiliary drainage pump **300** for smooth drainage of the wash water. The drainage pump **300** mentioned above is configured to perform drainage of wash water and to filter dirt drained together with the wash water simultaneously. However, this

## 22

embodiment requires a new structured drainage pump **300** because of the narrow installation space formed in the second treating part **20a**.

As follows, the drainage pump **300** according to this embodiment will be described in detail in reference to the accompanying drawings.

As shown in FIG. **25**, the drainage pump **300** according to an embodiment of the present invention is installed in a front edge portion of the drawer **100**. The drainage pump is configured of a filter part **310** and a pump part **320**. The pump part **320** is installed in the drawer **100** and the filter part **310** is detachably installed in an upper horizontal direction of the drawer **100**.

The reason why the filter part **310** is detachably in an upper portion of the drawer **100** vertically is that the installation space for the pump part **320** installed in the drawer is very narrow. In other words, if the filter part **310** is detachable forward or sideward with respect to the drawer **100**, a filtering area of the filter part **310** is reduced possibly making it difficult to perform smooth filtering. However, if the filtering effect of the filter part **310** is enough, the filter part **310** could be detached along a forward or sideward direction of the drawer **100**.

As shown in FIGS. **26** to **29**, the filter part **310** and the pump part **320** of the drainage pump may be detachably vertically.

Here, the filter part **310** is formed in a cylindrical shape having a hollow formed therein and it includes an inlet hole **311** formed in a lower portion thereof to draw the wash water therein and a plurality of filter holes **313** formed in an outer circumferential surface thereof, except the inlet hole **311**, to filter the wash water. A handle **315** is provided in a top of the filter part **310** to detach the filter part **310** from the pump part **320**. Here, a cut-out plane surface **317** is formed in a body of the filter part **310** to limit the insertion direction of the filter part **310**.

In the meanwhile, the pump part **320** includes a filter coupling part **321** configured to couple the filter part **310** thereto insertedly, a drainage chamber **328** in communication with the filter coupling part **321** and a pump **329** provided in the drainage chamber **328** to generate a pumping power.

Here, the filter coupling part **321** is formed in a cylindrical shape, with an open top to allow the filter part **310** to be inserted therein and a hollow formed therein. A raised surface **322**, corresponding to the cut-out surface **317** formed in the filter part **310**, is formed in an inner surface of the filter coupling part **321**. The insertion direction of the filter part **310** inserted in the filter coupling part **321** is determined by the shape of the raised surface **322** and the shape of the cut-out surface **317** corresponding to the raised surface **322**.

The filter coupling part **321** forms a relatively broad space, compared with the filter part **310**. A predetermined space where the wash water drawn via the inlet hole of the filter **310** passes the filter hole **313** of the filter part **310** is formed in the filter part **310**.

Meanwhile, a water inlet hole **323** corresponding to the inlet hole **311** of the filter part **310** is formed in a lower portion of the filter coupling part **321** to draw the wash water therein. It is preferable that the water inlet hole **323** contacts with the inlet hole **311** formed in the filter part **310** closely to supply the wash water drawn via the water inlet hole **323** toward the inlet hole **311**.

A wash water staying space **324** extending from the filter coupling part **321** is formed in the lower portion of the filter coupling part **321**. A drainage path **325** to pass the wash



water filtered by the filter part **310** therein is formed underneath the wash water staying space **324**. The drainage path **325** forms a moving passage of the wash water toward a lower center of the drainage chamber **328** which will be described later, specifically, a center of an impeller **341** of the pump **329** which will be described later.

The drainage chamber **328** is located adjacent to the filter coupling part **321**, beyond the drainage path **325** extended from the lower portion of the filter coupling part **321**. The pump **329** is installed in the drainage chamber **328** and an impeller **341**, rotated by the rotation of the pump **329**, is located in the drainage chamber **328**.

Moreover, a water outlet hole **342** is formed in a predetermined portion of the drainage chamber **328** to drain the wash water therethrough by the rotation of the impeller **341**. A drainage hole **345** is additionally formed in an opposite portion of the water outlet hole **342** to drain the wash water remaining in the drainage chamber **328** in the maintenance of the drainage pump **300**. The drainage hole **345** may be closed by an auxiliary cap (not shown).

In the meanwhile, when the drainage pump **300** is driven at a high speed in the above structure of the drainage chamber **328**, a pressure inside the drainage chamber **328** may be varied by the rotation of the impeller **341**. In other words, the pressure of the portion inside the drainage chamber **328** where the wash water is drained may be increased by the impeller **341** and the pressure of the portion where the wash water is drawn may be decreased by the suction of the impeller **341**.

Here, when the pressure is decreased by the suction of the impeller **341**, vapors might be generated in the wash water by the lowering pressure. The vapor generated in the drainage chamber **328** might affect the operation of the impeller **341**, only to result in poor water drainage and noise generated by the vapors during the rotation of the impeller **341**.

In the meanwhile, a partition wall **326** is located between the wash water staying space **324** and the drainage chamber **328** to partition off a predetermined space into the wash water staying space **234** and the drainage chamber **328**. The partition wall **326** includes a through hole **327** to allow the wash water staying space **324** to communicate with the drainage chamber **328**, rather than the drainage path **325**.

When the pressure inside the drainage chamber **328** is decreased by the rotation of the impeller **341**, the through hole **327** draws the wash water inside the wash water staying space **324** into the drainage chamber **328** to prevent the pressure inside the drainage chamber **328** from decreasing. Because of that, the pressure inside the drainage chamber **328** is decreased by the rotation of the impeller **341** and the smooth driving of the pump may be maintained.

Meanwhile, the second treating part **20a** of the laundry apparatus **1** described above is movably supported by the supporting device **500**. In this case, the second tub **200** is moved by a shock generated by the movement of the laundry apparatus **1** and it might collide with the inside of the drawer **100** to cause damage and breakage thereof. As a result, a fixing material configured to prevent the movement of the second tub **200** when the laundry apparatus **1** is moved is required.

As shown in FIG. **30**, a transit bolt securing part **260** for securing the vibration of the second tub **200** when the laundry apparatus **1** is moved may be further formed in a predetermined portion of an outer circumferential surface of the second tub **200**. It is preferable that the transit bolt securing part **260** is formed in a rear portion of the second tub **200**. When the laundry apparatus **1** is moved, a transit bolt **262** passing through the second cabinet **20** is secured to

the transit bolt securing part **260** formed in the rear portion of the second tub **200**, to prevent vibration of the second tub **200**.

Alternatively, a transit bolt **262** passing through the drawer **100** and the second cabinet **20** is secured to the transit securing part **260**. In this case, vibration of the second tub **200** is prevented by the transit bolt **262** secured via the drawer **100** and vibration of the second cabinet **20** and the drawer **100** are prevented from being open from the second cabinet **20**, when the laundry apparatus **1** is moved.

Moreover, the securing process of the second tub **200** secured by the transit bolt **262** as mentioned above may prevent the horizontal vibration of the second tub **200**. However, the horizontal and vertical vibration might be generated complicatedly, when the laundry apparatus **1** is moved. Because of that, it is necessary to prevent the vertical vibration of the second tub **200**. The bottoms of the second cabinet **10** and the drawer **100** are open and an auxiliary vibration preventing material **270** is inserted in the open bottoms of the second cabinet **20** and the drawer **100**, to prevent the vertical vibration of the second tub **200**.

The auxiliary vibration preventing material **270** is formed of a predetermined material such as Styrofoam having a shape corresponding to the shape of space located between the second tub **200** and the drawer. The auxiliary vibration preventing material **270** is inserted into the drawer **100** from the bottom of the second cabinet **20**, to fix the second tub **200**. As a result, the vibration of the second tub **200** may be prevented by the transit bolt **262** and the auxiliary vibration preventing material **270** mentioned above, when the laundry apparatus **1** is moved.

Meanwhile, when the drum is rotated, a balancer used to reduce eccentricity of the drum may be provided. However, the second cabinet **20** provided in the laundry apparatus according to some embodiments may have a smaller washing capacity, that is, at least one of a smaller volume and a smaller height than the first cabinet **20**. In case of providing a balancer at the second drum **600**, the space for installing the balancer makes the capacity of the second drum **600** smaller or the installation space of the balancer itself may be insufficient.

As a result, in case a ball balancer is provided in the second drum **600** of the second cabinet **20**, the present invention provides a balancer capable of reducing an installation space. For that, the balancer according to an embodiment may be employed as at least a part of an outer wall of the drum **600**.

If the balancer is provided in the drum like the conventional laundry apparatus, a part of the volume inside the drum is used as an installation space for the balancer and the drum capacity decrease cannot be avoided. In contrast, if the balancer is provided outside the drum, the internal space of the second cabinet **20** is narrow and it is difficult to secure an enough space with the tub.

As a result, an outer wall of the balancer may be used as a part of an outer wall of the second drum **600**, not to reduce the capacity of the second drum **600** and to secure the installation space for the balancer. As follows, the balancer will be described in detail in reference to the accompanying drawings.

In reference to FIGS. **31** and **32**, a balancer **630** according to an embodiment is provided at a top of the drum **600** to be substantially employed as a predetermined portion of a wall of the second drum **600**. In other words, the balancer **630** is provided at the top of the drum **600**. It can be expected that the top of the drum second drum **600** is extended as much as the height of the balancer **630**. For that, the balancer **630**

may be projected from the top of the second drum 600 a predetermined distance. In other words, the balancer 630 according to some embodiments may be projected from a top end of the second drum 600, rather than provided inside or outside the second drum 600.

In this case, as shown in FIG. 31, an outer circumferential surface of the balancer 630 may be substantially continuous from an outer circumferential surface of the second drum 600. The outer circumferential surface of the balancer 630 may be provided along the same surface which is identical to the outer circumferential surface of the second drum 600, that is, a predetermined virtual surface. If the balancer 630 is projected outwardly from the second drum 600, the internal space of the second cabinet 20 is narrow and interference between the balancer 630 and the second tub 200 might be generated during rotation of the second drum 600, to cause an error. Since the balancer 630 according to some embodiments forms at least a part of the wall of the second drum 600, the balancer 630 may minimize the capacity decrease of the second drum 600.

The connection between the balancer 630 and the second drum 600 will be described as follows. For example, at least one first connecting portion 631 is provided in a bottom of the balancer 630 and at least one second connecting portion 635 corresponding to the first connecting portion 631 may be provided in the top of the second drum 600. Here, the first connecting portion 631 may include a first extended portion 632 extending from the bottom of the balancer 630 downwardly and a first seating portion 643. The second connecting portion 635 includes a second extended portion 636 extending from the top of the second drum 600 upwardly and a second seating portion 638. The first and second extended portions 632 and 636 may include first and second connecting holes 633 and 637, respectively.

When the balancer 630 is connected with the second drum 600, the first extended portion 632 of the balancer 630 may be seated on the second seating portion 638 of the second drum 600 and the second extended portion 636 of the second drum 600 may be seated on the first seating portion 634 of the balancer 630. In other words, when the first and second extended portions 632 and 636 are seated on the second and first seating portions 638 and 634, respectively, the first connecting hole 633 is in communication with the second connecting hole 637. Because of that, a fastening material passing through the first and second connecting holes 633 and 637 may be fastened to connect the balancer 630 to the second drum 600.

In the meanwhile, if the fastening material 650 is projected toward the outside of the second drum 600, interference with the second tub 200 might be generated during the rotation of the second drum 600. Because of that, a concave portion 634a may be provided to prevent the fastening material 650 from being projected toward the outside of the second drum 600. The concave portion 634a may be provided between the first connecting portion 631 and the second connecting portion 635. When it is fastened, the fastening material 650 is inserted in the concave portion 634a and it is prevented from being projected toward the outside of the second drum 600.

The second cabinet 20 of the laundry apparatus 1 according to an embodiment may have at least one of a smaller volume and a smaller height than the first cabinet 10. The height of the second drum 600 may be smaller than that of the first drum. In some embodiments, the balancer 630 is provided on the top of the second drum 600, the height of the second drum 600 may be smaller than a diameter of the second drum 600. In other words, the balancer 630 forms a

predetermined part of the outer wall of the second drum 600 and the height of the second drum 600 itself may be smaller accordingly. As a result, the height of the second drum 600 may be smaller than the diameter of the second drum 600.

When the height of the second drum 600 is smaller as mentioned above, compared with that of the conventional drum, it could be difficult to manufacture the second drum 600 according to a conventional method. In other words, a plate type side wall is rolled to be circular and the conventional drum is formed. A base is manufactured independently and the base is connected with the side wall. The height of the second drum 600 according to this embodiment is smaller than that of the conventional drum. The second drum 600 may not be properly manufactured if a side wall and a base are independent and then connect with each other to form the drum. Because of that, to manufacture the second drum 600 of the laundry apparatus according to some embodiments, a single metal sheet is provided and the single metal sheet is used to manufacture the second drum 600 via a drawing process. This is because the height of the second drum 600 is relatively smaller. It is possible to manufacture the second drum 600 in the drawing process and it is further possible to manufacture the second drum 600 according to the embodiment in a single drawing process. As a result, a side wall and a base may be integrally formed as one body to be the second drum 600 according to the embodiment.

The conventional drum provided in the laundry apparatus includes a plurality of drainage holes formed in the side wall thereof to drain water inside the drum. When the drum is rotated, the water inside the drum is drained toward the tub to perform washing and rinsing more smoothly. To form the plurality of the drainage holes, the drum is punched from the inside toward the outside.

However, the second drum 600 according to one embodiment may be integrally manufactured as one body via the drawing process, with a reduced height. If the side wall of the second drum 600 is punched to form drainage holes, portions near the drainage holes might be distorted. In a severe case, a circular profile of the second drum might be distorted during punching of the side wall to form drainage holes. If the profile of the second drum is not uniformly even, the distance with the tub may not be uniform when the drum is rotated, which may cause an error.

To solve this potential problem, the second drum 600 according to some embodiments may not include drainage holes formed along the side wall. Rather, the second drum 600 may include only a drainage hole formed in a drum base 620. When the drum base 620 of the second drum 600 is rotated, the distance with the tub 200 is not so fatal, compared with the side wall, and it is possible to form the drainage hole in the drum base 620.

However, when only the drum base 620 includes the drainage hole, water inside the second drum 600 might leak outside via the top of the second drum 600 by a centrifugal force during the rotation of the second drum 600 and the water might leak outside the second tub 200 according to the rotational speed of the second drum 600.

As a result, auxiliary means for drain the water inside the second drum 600 may be further provided in the side wall to circulate the water via the space with the second tub 200.

For example, according to an embodiment, an opening 640 is provided between the second drum 600 and the balancer 630 to drain the water inside the second drum toward the second tub 200 during the rotation of the second drum 600. In other words, as shown in FIG. 32, the balancer 630 and the second drum 600 may be connected via the first and second connecting portions 631 and 635. The opening

640 may be provided between the first and second connecting portions 631 and 635. When the water is lifted toward an inner wall of the second drum 600 by the centrifugal force, the water inside the second drum 600 may be drained to a predetermined space formed between the second tub 200 and the second drum 600 via the opening 640. The drained water may be stored in the space formed between the second tub 200 and the second drum 600 or it may be re-supplied to the inside of the second drum 600 via the drainage hole provided in the drum base 620 of the second drum 600.

Meanwhile, the drum integrally manufactured as one body in the drawing process may have a deterioration in strength in comparison with a drum manufactured in a conventional process. Also, the internal volume of the second cabinet 20 is narrow and the volume, that is, the washing capacity of the second tub 200 provided in the second cabinet may be decrease. The second drum 600 according to this embodiment includes a structure capable of solving these disadvantages, which will be described as follows.

In reference to FIGS. 33 and 34, the second drum 600 according to some embodiments may reinforce the strength of the drum itself and it may include a stepped portion 622 provided in the drum base 620 to enhance the washing capacity of the second drum 600. Here, the stepped portion 622 may be provided to make an outer portion of the drum base 620 lower than a center thereof. The stepped portion 622 is provided to reinforce the strength of the second drum 600 and to make the second drum 600 getting lower as coming toward the outer portion. Because of that, the internal volume of the second drum 600 may be increased.

Moreover, to reinforce the strength of the second drum 600, the second drum 600 according to this embodiment includes a first convex portion 624 extending towards the center of the drum base 620 from an outer portion of the drum base 620. For example, at least one convex portion 624 may be provided and the at least one convex portion 624 may be extended toward the center from the outer portion of the drum base 620. In this case, the first convex portion 624, extending toward the center of the drum base 620, may be connected with the stepped portion 622 of the drum base 620. As a result, the strength of the second drum according to this embodiment may be reinforced by the stepped portion 622 provided in the drum base 620 and the first convex portion connected with the stepped portion 622.

In the meanwhile, the second drum 600 may be rotatable within the second tub 200. In this case, the second drum 600 may include a connecting portion 660 extended from the shaft 700 to be connected therewith, in communication with the shaft 700, to allow the second drum 600 to be rotatable. The connecting portion 660 may be connected with the second drum 600 by a fastening material (229, see FIG. 33) such as a bolt. The connecting portion 660 extends from the shaft 700 provided in the center of the drum base 620 in a radial direction. A seating portion may be provided in the drum base 620 of the second drum 600 to seat the connecting portion 660 thereon. The seating portion may be created to be a second convex portion 626 extending outwardly from the center of the drum base 620. In other words, the connecting portion 660 may be seated in a lower portion of the second convex portion 626 and it may be connected with the second drum 600 by the fastening material 650.

When the stepped portion 622 is provided in the drum base 620 of the second drum 600 as mentioned above, a stepped portion 221 may be provided in a tub base 220 of the second tub 200 to maintain the predetermined distance with

the second drum 600 and to reinforce the strength of the second tub 200. The stepped portion has an outer portion lower than a center portion.

According to the laundry apparatus 1 described above, the balancer 630 forming at least a predetermined part of the wall of the drum may be provided. Because of that, when the second cabinet 20 is provided, the second drum 600 may be installed in the second cabinet 20 having a relatively narrow internal space and the drum capacity decrease may be minimized.

Meanwhile, drainage of the wash water may be performed in the first treating part 10a located beyond the second treating part and the second treating parts 20a. At this time, the wash water drained from the first treating part 10a might flow backward to the second treating part 20a. It is required to improve the drainage structure of the first and second treating parts 10a and 20a.

As follows, the drainage structure of the first and second treating parts 10a and 20a provided in the laundry apparatus 1 according to embodiments of the present invention will be describe in detail in reference to the accompanying drawings.

As shown in FIG. 13, a first drainage pipe 16 is provided in the first treating part 10a to drain the wash water used in the first treating part 10a. The first drainage pipe 16 is in communication with the first tub of the first treating part 10a. A second drainage pipe 480 is provided in the second treating part 20a to drain the wash water used in the second treating part 20a. The second drainage pipe 480 is in communication with the second tub 200. The first drainage pipe 16 of the first treating part 10a and the second drainage pipe 480 of the second treating part 20a may be integrated outside the cabinet 1a. A junction pipe 485 is provided at a junction point (P) and the junction pipe 485 is arranged in a "U" shape, to prevent the drained wash water from flowing backward.

Together with that, the second drainage pipe 480 of the second treating part 20a is upward with respect to the ground for a predetermined period and downward again to be integrated with the first drainage pipe 16 of the first treating part 10a. The second drainage pipe 480 has an outlet point (O) led out from the bottom of the second tub 200, a maximum point (M) of the highest position with respect to the ground and a junction point (P) integrated with the first drainage pipe 16 of the first treating part 10a.

Here, the outlet point (O) and the junction point (P) are located higher than the maximum point (M). In other words, the maximum point (M) is located higher than the outlet point (O) and the junction point (P). As a result, the wash water of the junction point (P) may be prevented from flow backward into the second tub 200 against the drainage direction.

When the laundry is washed by using the second treating part 20a, too many bubbles might be generated in the second tub 200. When too many bubbles are generated in the second tub 200, a friction may be generated by the bubbles located between the second drum 600 and the second tub 200. The friction interferes with efficient rotation of the second drum 600.

Because of that, the second treating part 20a may include a bubble outlet pipe 490 to discharge the bubbles generated in the second tub 200. An end of the bubble outlet pipe 490 is coupled to a predetermined portion of the top of the second tub 200 and the other end is connected with the second drainage pipe 480. Preferably, the end of the bubble outlet pipe 490 is coupled to a top surface of the top cover 210 of the second tub 200.

29

In addition, a check valve 487 may be provided at a connected point between the bubble outlet pipe 490 and the second drainage pipe 480. The check valve 487 may be selectively closed according to a case of discharging bubbles or a case of discharging wash water.

In the meanwhile, the bubble outlet pipe 490 may be used to discharge too much steam generated in the second tub 200. The feature used to discharge the too much steam generated in the second tub 200 is the same as the feature used to discharge the bubbles and detailed description thereof will be omitted accordingly.

It will be apparent to those skilled in the art that various modifications and variations can be made in embodiments of the present invention without departing from the spirit or scope of the inventions. Thus, it is intended that embodiments of the present invention cover the modifications and variations of embodiments of this invention provided they come within the scope of the appended claims and their equivalents.

What is claimed is:

1. A laundry treatment apparatus comprising:

- a housing;
- a tub provided in the housing, configured to receive water and having an open top;
- a drum rotatably provided in the tub and having an open top;
- a tub cover coupled to a top portion of the tub to cover the open top of the tub, the tub cover comprising:
  - an opening formed in a first portion of the tub cover to receive laundry,
  - a chamber support formed in a second portion of the tub cover, and
  - a cover coupled to the chamber support through a hinge to open or close the opening;
- a water supply pipe passing through a rear surface of the housing;
- a water chamber provided on the chamber support and configured to guide water to the tub through the tub cover,
- wherein the water chamber is arranged at the center of the open top of the drum; and

30

a water supply hose disposed on the chamber support and having a first end connected to the water supply pipe and a second end connected to the water chamber; and a chamber cover disposed on the chamber support and configured to cover the water chamber,

wherein the water chamber and the water supply hose are disposed between the chamber cover and the chamber support, and

wherein a cross section of the water chamber is larger than a cross section of the water supply hose.

2. The laundry treatment apparatus according to claim 1, wherein the water supply hose is configured to be bent at a center of the chamber support in a width direction of the housing to fluidly communicate with the water chamber.

3. The laundry treatment apparatus according to claim 2, further comprising:

a plurality of fixers formed around the water chamber to fix the water chamber to the chamber support.

4. The laundry treatment apparatus according to claim 1, wherein the cover comprises:

- a frame having a handle; and
- a transparent window secured in the frame.

5. The laundry treatment apparatus according to claim 1, wherein the water chamber is located at the center of the chamber support, and wherein the first portion is a front portion of the tub cover and the second portion is a rear portion of the tub cover.

6. The laundry treatment apparatus according to claim 1, further comprising:

- a cabinet,
- wherein the housing is a drawer that is configured to be extracted from and retracted into the cabinet.

7. The laundry treatment apparatus according to claim 2, wherein the water supply hose is inserted into the tub cover between the chamber cover and the chamber support and arranged along an inner surface of the top cover in a circumferential direction up to the center of the chamber support.

\* \* \* \* \*