



INTERNATIONAL APPLICATION PUBLISHED UNDER THE PATENT COOPERATION TREATY (PCT)

<p>(51) International Patent Classification ⁶ : E04H 4/00, F16B 21/02</p>	<p>A1</p>	<p>(11) International Publication Number: WO 98/57012 (43) International Publication Date: 17 December 1998 (17.12.98)</p>
<p>(21) International Application Number: PCT/CA98/00556 (22) International Filing Date: 8 June 1998 (08.06.98) (30) Priority Data: 08/871,539 9 June 1997 (09.06.97) US (71) Applicant: 2679965 CANADA INC. [CA/CA]; 9031 Salley, LaSalle, Quebec H8R 2C8 (CA). (72) Inventors: SHAANAN, Gad; 49 Oakland, Montreal, Quebec H3Y 1P1 (CA). FRANCOVICH, Walter; 17420 Rue Antoine-Faucon, Pierrefonds, Quebec H9J 3S8 (CA). DUBEAU, Serge; 3736-B Parc Lafontaine, Montreal, Quebec H2L 3M4 (CA). (74) Agents: MITCHELL, Robert et al.; Swabey Ogilvy Renault, Suite 1600, 1981 McGill College Avenue, Montreal, Quebec H3A 2Y3 (CA).</p>		<p>(81) Designated States: AL, AM, AT, AU, AZ, BA, BB, BG, BR, BY, CH, CN, CU, CZ, DE, DK, EE, ES, FI, GB, GE, GH, GM, GW, HU, ID, IL, IS, JP, KE, KG, KP, KR, KZ, LC, LK, LR, LS, LT, LU, LV, MD, MG, MK, MN, MW, MX, NO, NZ, PL, PT, RO, RU, SD, SE, SG, SI, SK, SL, TJ, TM, TR, TT, UA, UG, UZ, VN, YU, ZW, ARIPO patent (GH, GM, KE, LS, MW, SD, SZ, UG, ZW), Eurasian patent (AM, AZ, BY, KG, KZ, MD, RU, TJ, TM), European patent (AT, BE, CH, CY, DE, DK, ES, FI, FR, GB, GR, IE, IT, LU, MC, NL, PT, SE), OAPI patent (BF, BJ, CF, CG, CI, CM, GA, GN, ML, MR, NE, SN, TD, TG).</p> <p>Published With international search report. With amended claims.</p>

(54) Title: ABOVE-GROUND SWIMMING POOL

(57) Abstract

An above-ground pool made up of a plurality of posts (11), wherein each post (11) is a blow-molded unit having a base portion (12) and a top portion with a coping seat (22). A plurality of coping members (30a... 30n) also blow-molded are each telescopically received one end to the other at the coping seat (22) of the top of each post, and a one-piece fastener (50) engages the overlapping telescopic ends (38, 44) of the coping members to the top of the post (11). A bracket (70) is provided at the base of the post (11), the bracket (70) having a rail (82) for receiving track segments (84) wherein an elongated flexible metal wall (64) is inserted. The top of the flexible wall is retained by the coping member (30) against the post (11).

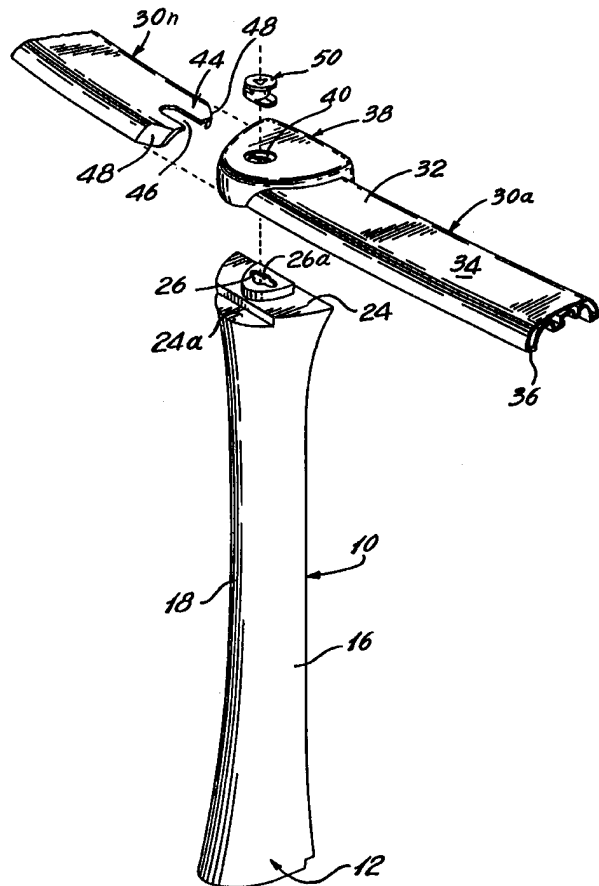

FOR THE PURPOSES OF INFORMATION ONLY

Codes used to identify States party to the PCT on the front pages of pamphlets publishing international applications under the PCT.

AL	Albania	ES	Spain	LS	Lesotho	SI	Slovenia
AM	Armenia	FI	Finland	LT	Lithuania	SK	Slovakia
AT	Austria	FR	France	LU	Luxembourg	SN	Senegal
AU	Australia	GA	Gabon	LV	Latvia	SZ	Swaziland
AZ	Azerbaijan	GB	United Kingdom	MC	Monaco	TD	Chad
BA	Bosnia and Herzegovina	GE	Georgia	MD	Republic of Moldova	TG	Togo
BB	Barbados	GH	Ghana	MG	Madagascar	TJ	Tajikistan
BE	Belgium	GN	Guinea	MK	The former Yugoslav Republic of Macedonia	TM	Turkmenistan
BF	Burkina Faso	GR	Greece	ML	Mali	TR	Turkey
BG	Bulgaria	HU	Hungary	MN	Mongolia	TT	Trinidad and Tobago
BJ	Benin	IE	Ireland	MR	Mauritania	UA	Ukraine
BR	Brazil	IL	Israel	MW	Malawi	UG	Uganda
BY	Belarus	IS	Iceland	MX	Mexico	US	United States of America
CA	Canada	IT	Italy	NE	Niger	UZ	Uzbekistan
CF	Central African Republic	JP	Japan	NL	Netherlands	VN	Viet Nam
CG	Congo	KE	Kenya	NO	Norway	YU	Yugoslavia
CH	Switzerland	KG	Kyrgyzstan	NZ	New Zealand	ZW	Zimbabwe
CI	Côte d'Ivoire	KP	Democratic People's Republic of Korea	PL	Poland		
CM	Cameroon	KR	Republic of Korea	PT	Portugal		
CN	China	KZ	Kazakstan	RO	Romania		
CU	Cuba	LC	Saint Lucia	RU	Russian Federation		
CZ	Czech Republic	LI	Liechtenstein	SD	Sudan		
DE	Germany	LK	Sri Lanka	SE	Sweden		
DK	Denmark	LR	Liberia	SG	Singapore		
EE	Estonia						

ABOVE GROUND SWIMMING POOL

Technical Field

The present invention relates to an above ground swimming pool, and more particularly, to a swimming pool having a water impermeable liner, at least an
5 upstanding panel surrounding the liner, and an improved coping structure with upstanding posts.

Background Art

Present day above ground pools generally
10 have posts and coping structures supporting a single endless panel. However, most such structures rely on nuts and bolts to connect the many posts and coping elements together. On a large pool, that is, an obround pool in the order of 40 feet, the number of posts and
15 coping sections is considerable, and as a result, the number of nuts and bolts that must be utilized is considerable. The labor required for erecting such a pool is, therefore, substantial.

Since the posts and coping elements must
20 form an enclosed loop, the elements forming it must be produced with precision. There can be very little tolerances when erecting a structure that might measure over 100 feet in terms of the loop being formed.

Examples are illustrated in U. S. Patents
25 3,274,621, Diamond et al, 1966; 3,869,736, Valois et al, 1975; 4,413,361, Wolf et al, 1983; and 5,155,872, Aymes, 1992. Each one of these pools shows the necessity of precision in the fabrication of the posts and coping sections or upper rails and lower rails. Even
30 assuming relatively low tolerances in the fabrication of swimming pool components, imprecise connections will still occur over the overall installation of the pool wall because of the accumulation of the tolerances over the relatively large dimensions of the loop being
35 formed. These problems will occur at the installation phase in the field and must be overcome by sometimes

damaging the last components being connected in order to get the parts to fit.

Another disadvantage that has been found with conventional above ground pool kits, as represented by the above patents, is the number of fasteners that must be manipulated in the field in order to erect the pool. Such manipulation of fasteners, such as nuts and bolts, requires an inordinate amount of labor at the site.

10 **Disclosure of the Invention**

It is an aim of the present invention to provide an improved above ground pool construction that will overcome the problems mentioned above.

It is a further aim of the present invention to provide an above ground pool wherein the various elements, such as the upper rails or coping elements, can be telescoped one with the other in order to compensate for any imperfections.

It is still a further aim of the present invention to provide an above ground pool with elements, such as posts and coping components, that are molded of resin material especially by blow-molding. Since it is practically impossible to blow-mold such elements with small dimensional tolerances, it would not be possible to produce a practical, large, above ground swimming pool made of blow-molded components without allowing for some degree of adjustment such as having these components telescopically adjustable.

It is a further aim of the present invention to provide a special, simple, one-piece fastener that can be utilized with the components of the present invention and thus eliminate the necessity of using a large number of nuts and bolts.

A construction in accordance with the present invention comprises a kit for an above ground pool, including a plurality of posts with each molded in one piece from resin material and having a base

portion and a top portion with a coping seat. A plurality of coping elements are each molded in one piece from resin material and have one end including a female coupling member and the other end of the coping member having a male longitudinally slotted coupling member adapted to telescopingly engage the female coupling member. A one-piece fastening member is adapted to engage the coupled male and female members when they are telescoped together end to end and coincident with the coping seat on the top of one of the posts, whereby the fastening member will engage the post and fix the coupling members of adjacent coping members. The kit also includes bottom rail sections, a pool panel, and a pool liner adapted to be supported by the coping so formed.

In a more specific embodiment of the present invention, the fastener member is a one-piece member having a top tool-engageable portion, a stem portion, and opposed wings extending from the bottom of the stem having camming surfaces such that, when the fastener member is passed through the slots in at least two components of the kit, the fastener may be rotated to secure the components together.

Thus, the pool is simple to erect and does not require professional installers but may be erected by amateurs.

In a still more specific embodiment, the posts and coping members are blow-molded.

Brief Description of the Drawings

Having thus generally described the nature of the invention, reference will now be made to the accompanying drawings, showing by way of illustration, a preferred embodiment thereof, and in which:

Fig. 1 is a perspective view of an above ground pool, partly in dotted lines, including elements in accordance with the present invention;

Fig. 2 is an exploded perspective view of a detail of the present invention;

Fig. 3 is a vertical cross-section of an element shown in Fig. 2;

5 Fig. 4 is a vertical cross-section, similar to Fig. 3, but of another embodiment of the same element;

Fig. 5 is a fragmentary enlarged vertical cross-section of a detail of the present invention;

10 Fig. 6 is an enlarged fragmentary horizontal cross-section showing the detail of Fig. 5;

Fig. 7 is a perspective view of a detail of the present invention;

15 Fig. 8 is a side elevation of the detail shown in Fig. 7;

Fig. 9 is a vertical cross-section including the detail of Fig. 7 and Fig. 8;

Fig. 10 is a perspective view of the detail illustrated in Fig. 9; and

20 Fig. 11 is an exploded view showing how the ends of a metal band according to the invention are connected together.

Mode For Carrying Out The Invention

25 Referring now to the drawings, there is shown a swimming pool 8 forming an obround loop. The pool is shown with a typical pool liner 66 and a structure including upstanding posts 10 and 11 as well as coping elements 30 extending between each post.

30 Fig. 2 shows a typical post 10 along with its connection with the coping members 30. The post 10, as shown in Figs. 2, 3, and 5, includes an elongated upstanding blow-molded plastic member having a base 12, a front wall 14 which is a planar flat wall, a rear wall 18, and side walls 16. The post is hollow as shown
35 at 20 in Fig. 3. The post has a coping seat 22 defined by stepped shoulders 24, 24a and an upstanding member having an elongated opening 26 intersecting a circular

central opening 26a. The post 10 is designed for a circular pool or the ends of an obround pool, as shown in Fig. 1. The post 11, shown in Fig. 4, has a more pronounced flare towards a larger base 12a. Thus, the rear wall 18a has a fairly pronounced concave curve and this to provide a larger base 12a for greater support along the linear sides of the obround pool 8. However, for the purposes of the present invention, the posts 10 and 11 are quite similar in structure. As shown in Fig. 4, a ballast, such as water or sand 21, may be injected into the hollow interior 20 of the posts 10 or 11 once the post has been erected in order to give the post more stability and to strengthen the column formed.

The coping 30 may also be made from a blow-molding process of a suitable thermoplastic material. The coping member 30 may be linear or slightly curved depending on its position on the swimming pool, that is, if it is in a radius at the end of the pool or in the straight walls on the sides of an obround pool. Several coping members having different radii will be manufactured for use with different sized pools. However, each coping member has a beam structure 32 with a top surface 34 and a bottom surface 36. The top surface 34 is normally smooth without any sharp corners while the bottom structure may be provided with different strengthening ribs and normally a recess for receiving the pool panel and liner.

The coping 30 includes a female coupling member 38 at one end thereof and a male coupling member 44 at the other end thereof. The female coupling member 38, as shown in Figs. 2, 5, and 6, includes a recessed portion 42 and an opening 40 which, when mounted to the post 10, will be coincident with the opening 26 in the top of the post 10.

The male coupling member 44 at the other end of the coping member 30 includes an elongated open slot 46 and tapered ends 48.

The kit for erecting a pool includes several coping members 30a to 30n. The male coupling member 44 of coping member 30n is inserted into the recess 42 of the female coupling member 38 in a telescopic sliding manner. The slot 46 will be aligned with the openings 26 and 40 in order to receive the fastening member 50.

As shown in Figs. 7 and 8, fastening member 50 includes a cap 52 with a socket 54 defined therein from the top. A stem 56 extends downwardly from the cap 52, and a pair of diametrically opposed wings 58 extends from the bottom of the stem 56. The wings 58 include camming surfaces 60, as shown in Figs. 7 and 8.

When it is desired to connect a post with a pair of coping members 30a and 30n, the coping member 30n, with its male coupling member 44, is inserted into the recess 42 of the female coupling member 38, and the male member 44 is adjusted telescopically therein. The fastener member 50 is then inserted through the opening 40 with the wings 58 aligned with the major axes of the elongated openings. The fastener 50 is pushed down until the wings 58 are within the post 10, that is, through the opening 26. The fastener 50 is then rotated 90° by means of a suitable tool inserted in the socket 52. By rotating the fastener member 50, the camming surfaces 60 will engage the interior of the camming seat 24 and the top surface of the female coupling member 38 to tightly sandwich the elements together. The coupling member 44 is adjustably aligned or telescoped within the female coupling member 38, and it does not matter to what depth the coupling member 44 has been inserted as long as the slot 46 is aligned vertically with the openings 40 and 26.

A bracket 70 is illustrated in Figs. 3, 9, and 10. The bracket has a hook 74 which engages in an opening 72 in the base 12 of a typical post 10. The bracket 70, as seen in Fig. 10, includes an upstanding portion 78 with opening 79 and narrow slot 79a. The

bracket also includes base member 80 mounting hook 74 at one end and a rail 82 at the front end of the base member 80. Track segments 84 are telescoped in the rail 82. One track segment 84 extends end to end
5 between two posts and is adapted to receive wall 64. Each bracket 70 is insertable within the base 12 of a respective post 10. The upstanding portion fits into the recessed front wall 20 of the post 10 at the rear of the recess 71. Complementary openings, including
10 opening 79, allow a fastener 50 to be inserted and to lock the bracket 70 with the post 10.

An elongated flexible metal panel 64 would typically be inserted in tracks 84, and the top edge would be retained within a recess 76 in the coping 30
15 when the coping 30 is closed and locked on the posts 10. The ends of metal band or wall 64 are folded over, as shown in Fig. 11 at 64a and 64b. These reinforced edges are perforated at 86a, 86b, and metal strips 88a, 88b overlie these edges 64a, 64b and have corresponding
20 openings 90. Metal fasteners 150, similar to fasteners 50, pass through the openings 90a, 86a, 86b, and 90b, to clamp the ends of wall 64 together.

A pool liner 66 is illustrated with the bead 68 overlapping the top edge of the panel 64 within the
25 recess 76.

CLAIMS:

1. A kit for an above ground pool comprising a plurality of posts each molded in one piece from resin material and having a base portion and a top portion with a coping seat, a plurality of coping elements each
5 molded in one piece from resin material and having one end with a female coupling member and the other end of the coping member having a male longitudinally slotted coupling member adapted to telescopically engage the
10 female coupling member, a one-piece fastener adapted to engage the male and female coupling members when they are telescopically coupled end to end and coincident with the coping seat on the top of one of the posts, whereby the fastening member will engage the post and
15 fix the coupled ends of adjacent coping members, the kit also including a pool panel and a pool liner adapted to be supported by the coping so formed.

2. A kit as defined in claim 1, wherein the coping seat at the top of the post includes an elongated opening, the female coupling member of the coping
20 member includes a similar elongated opening, and when the coping members are mounted to form a joint on the coping seat of the post, the elongated opening in the female coupling member is coincident with the elongated
25 opening in the coping seat of the post, and the elongated slot of the male member is aligned with the coincident openings, the fastener member includes a cap portion, a stem portion, and a pair of diametrically extending wings from the stem portion such that when
30 the fastening member is inserted in the coincident openings, the stem and the wings can be inserted with the wings aligned with the elongated openings, and the fastener member can then be rotated to lock the coping seat, male coupling member, and female coupling member
35 together.

3. A kit as defined in claim 2, wherein the male coupling member of the coping member can be telescoped longitudinally while the slot remains aligned with said opening in order to provide linear adjustment
5 of the coping members.

4. A kit as defined in claim 1, wherein the post is hollow and is blow-molded from resin material and includes a base which is larger than the coping seat area at the top of the post.

10 5. A kit as defined in claim 1, wherein the coping member is a hollow, blow-molded, one-piece member.

6. A fastener for joining at least two structural members, wherein the members are provided with
15 corresponding elongated openings to be aligned at a joint so formed, each member having at least planar surfaces surrounding the openings on opposite sides of the joint, the openings being elongated, the fastener member including a cap portion, a stem portion, and a
20 pair of diametrically extending wings from the stem portion, such that the fastener member, when inserted through the elongated openings with the wings aligned with the major axis of the elongated openings, will pass through the joint and the fastener member can be
25 rotated so that the cap and wings engage the opposed planar surfaces of the joint to lock the structural members together.

7. A fastener as defined in claim 6, wherein the wings have camming surfaces for engaging and urging
30 the structural members together when the fastener member is rotated.

8. A fastener as defined in claim 6, wherein the fastener is made of plastics material and injection molded in one piece.

9. A kit as defined in claim 1, wherein the base of the posts includes means for receiving a bracket and track member segments each having a length corresponding to the distance between the posts can be
5 telescopically secured within the brackets.

AMENDED CLAIMS

[received by the International Bureau on 12 November 1998 (12.11.98); original claims 1-6 amended; remaining claims unchanged (3 pages)]

1. A kit for an above ground pool comprising a plurality of hollow posts each molded in one piece from resin material and having a base portion and a top portion with a coping seat, the base portion having a cross-sectional dimension that is greater than a cross-sectional dimension of the top portion, a plurality of hollow coping elements each molded in one piece from resin material and having one end with a female coupling member and the other end of the coping member having a male coupling member adapted to engage the female coupling member, and a fastener adapted to engage the male and female coupling members when they are coupled end to end and coincident with the coping seat on the top of one of the posts, whereby the fastening member will engage the post and fix the male and female coupling members of adjacent coping members, the kit also including a pool panel and a pool liner adapted to be supported by the coping so formed.

2. A kit as defined in claim 1, wherein the hollow posts and hollow coping members are formed by blow molding.

3. A kit as defined in either of claims 1 or 2, wherein the fastener is a singular fastener for fastening the female coupling member to said male coupling member and to said coping seat on said post to form a joint, each joint including portions of the male coupling member defining a U-shaped slot disposed within the respective female coupling member and said coping seat, said coping members substantially compensating for tolerances.

4. A kit as defined in any one of claims 1, 2 or 3, wherein the coping seat at the top of the post includes an elongated opening, the female coupling

member of the coping member includes a similar elongated opening, and the male coupling member defines a U-shaped slot, and when the coping members are mounted to form a joint on the coping seat of the post, the elongated opening in the female coupling member is coincident with the elongated opening in the coping seat of the post, and the U-shaped slot of the male member is aligned with the coincident openings, the singular fastener includes a cap portion, a stem portion, and a pair of diametrically extending wings from the stem portion such that when the fastening member is inserted in the coincident openings, the stem and the wings can be inserted with the wings aligned with the elongated openings, and the fastener member can then be rotated to lock the coping seat, male coupling member, and female coupling member together.

5. A kit as defined in claim 4, wherein the male coupling member of the coping member can be telescoped longitudinally while the slot remains aligned with said opening in order to provide linear adjustment of the coping members.

6. A fastener system comprising:
at least two structural members, each structural member including an elongated opening with inner and outer planar surfaces surrounding said opening, each elongated opening including a major axis, each inner planar surface of a respective structural member opposing and contacting an outer respective planar surface of an adjacent respective structural member; and

singular fastening means for fastening a pair of said at least two structural members, said singular fastening means including a cap portion, a stem portion, a pair of diametrically extending wings projecting from said stem portion, said singular

fastening means passing through the respective opening in each structural member of said pair of structural members when said wings are aligned with the respective major axis of each respective opening, and when said singular fastening means is rotated, said wings engage the inner surface of a respective structural member to lock the pair of structural members, said singular fastening means substantially reducing a number of parts needed to lock a respective pair of structural members.

7. A fastener as defined in claim 6, wherein the wings have camming surfaces for engaging and urging the structural members together when the fastener member is rotated.

8. A fastener as defined in claim 6, wherein the fastener is made of plastics material and injection molded in one piece.

9. A kit as defined in claim 1, wherein the base of the posts includes means for receiving a bracket and track member segments each having a length corresponding to the distance between the posts can be telescopically secured within the brackets.

Fig. 1

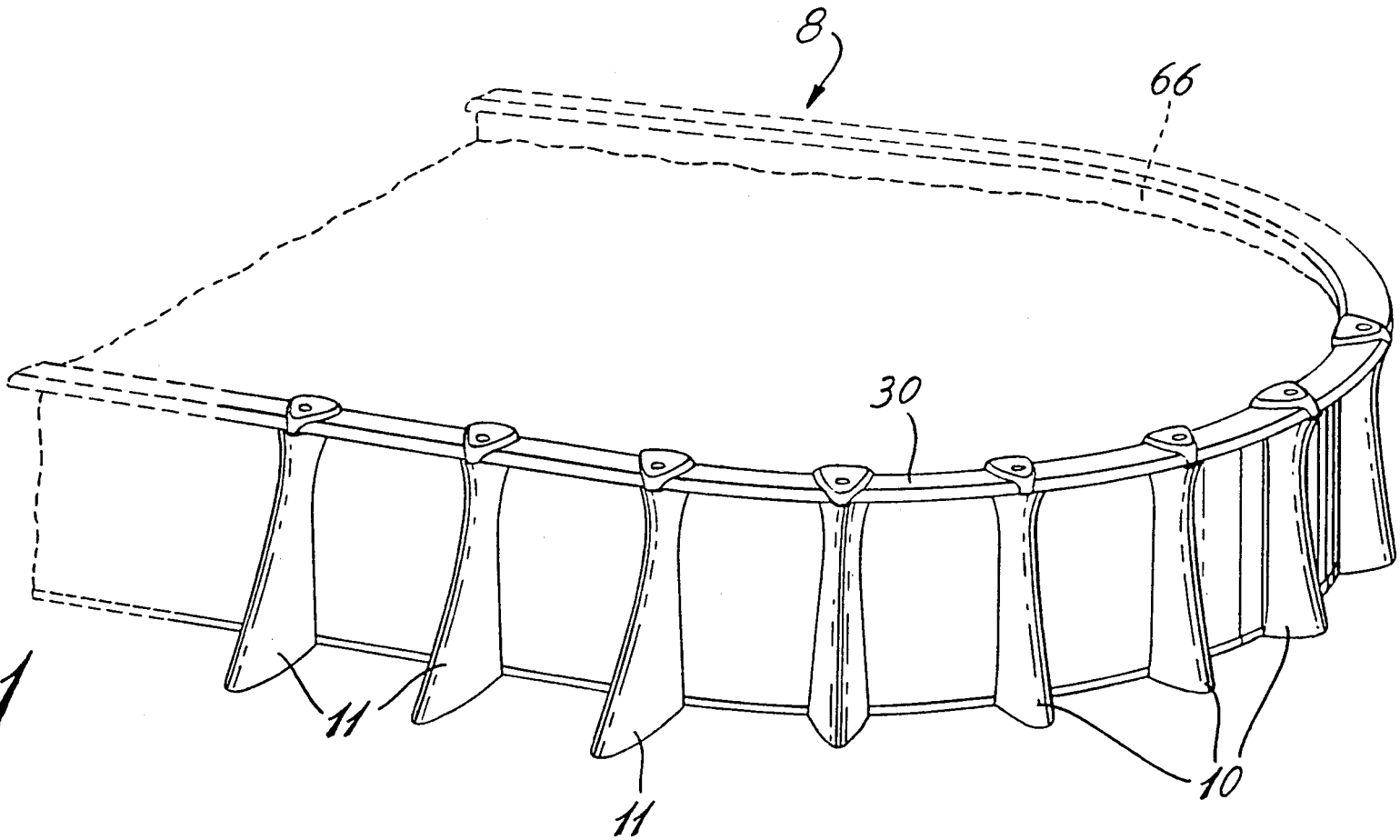

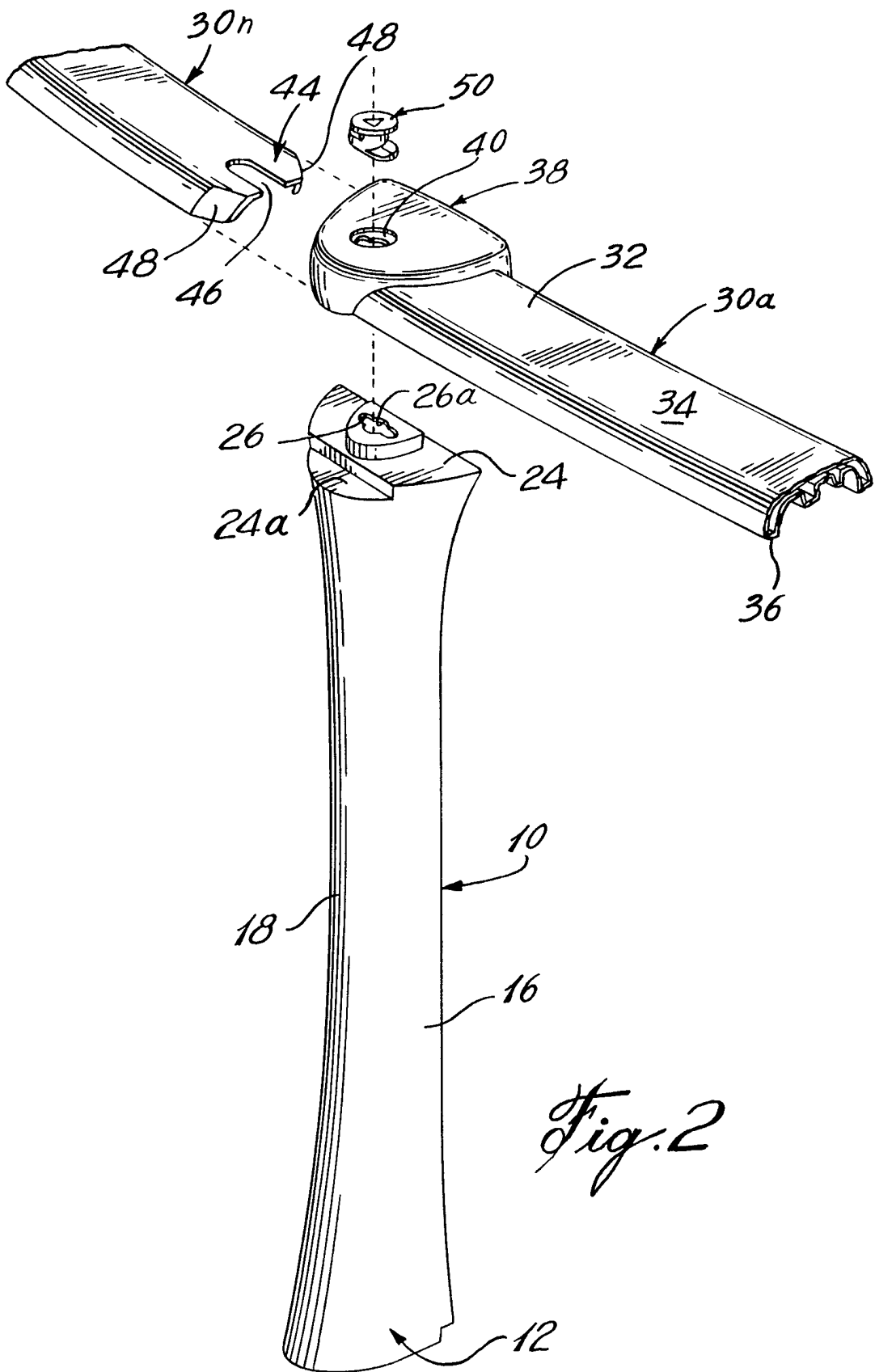
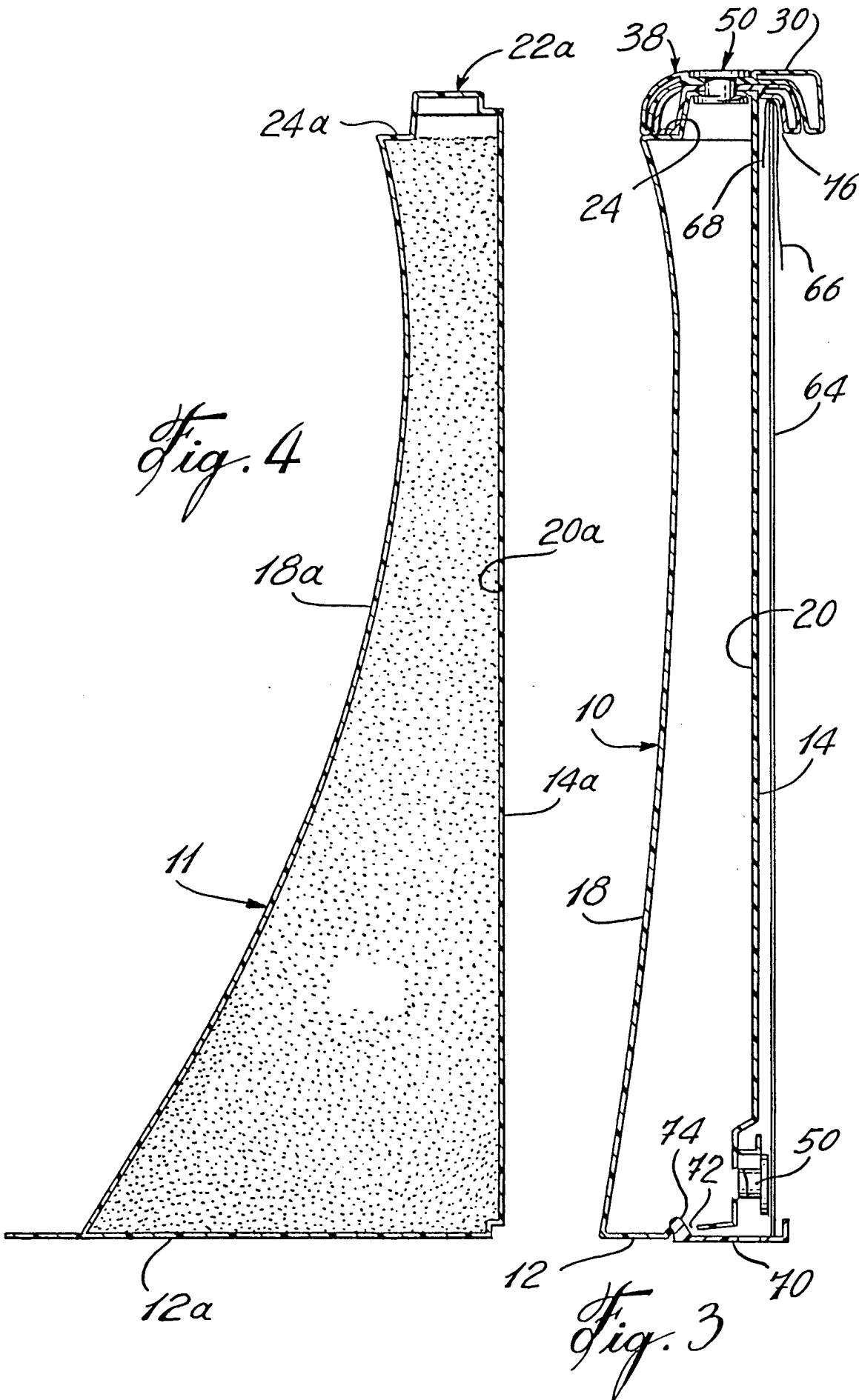

Fig. 2



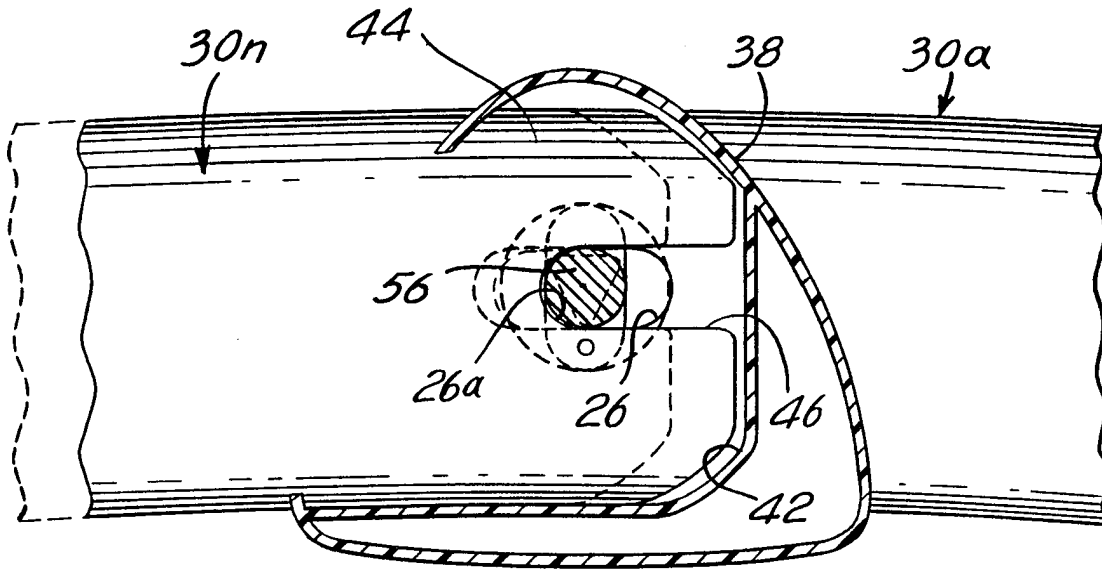

Fig. 6

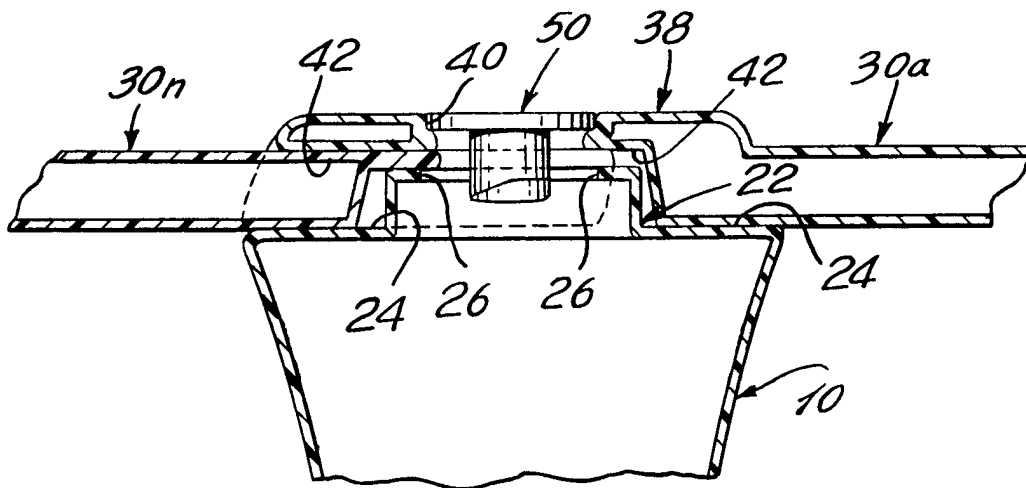
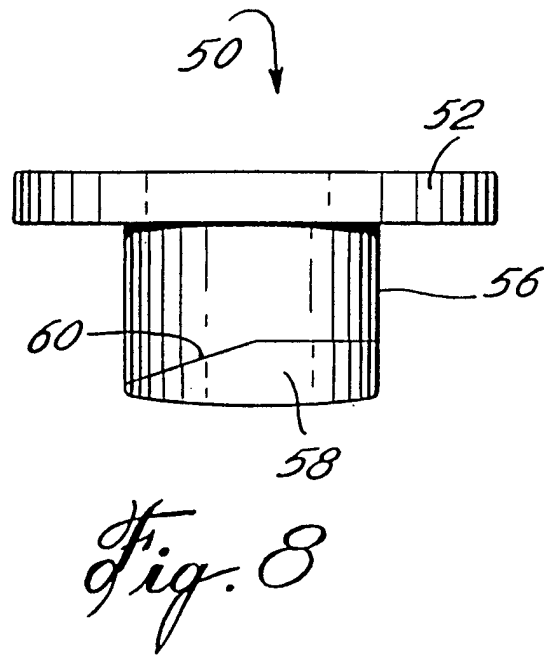
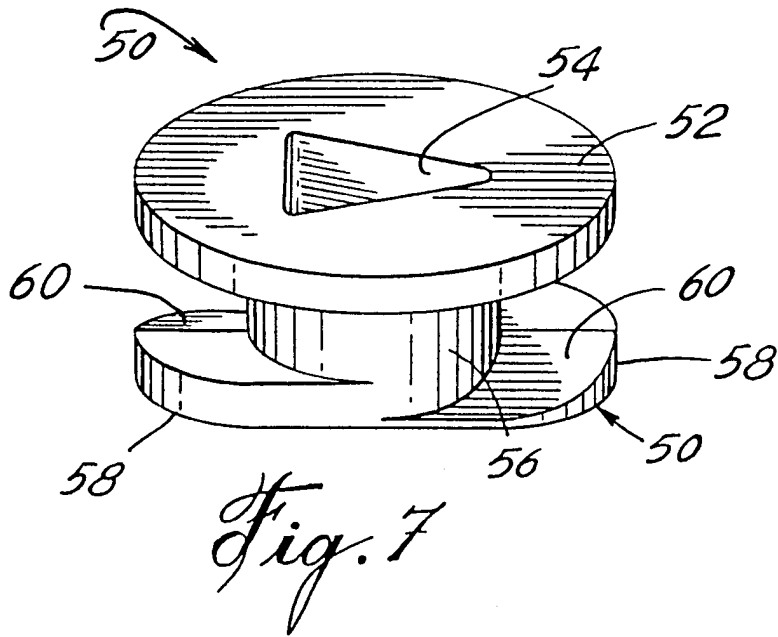

Fig. 5



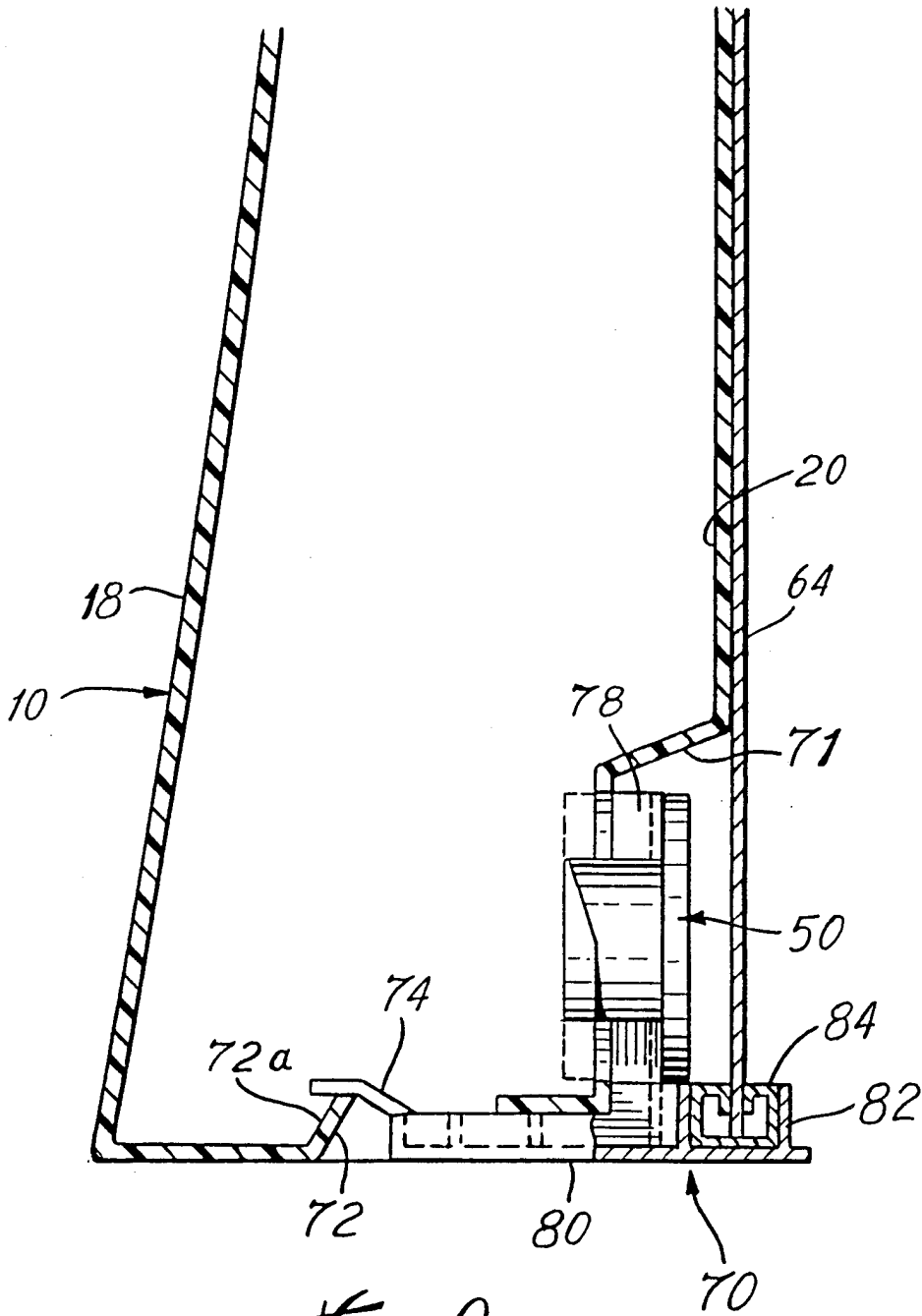

Fig. 9

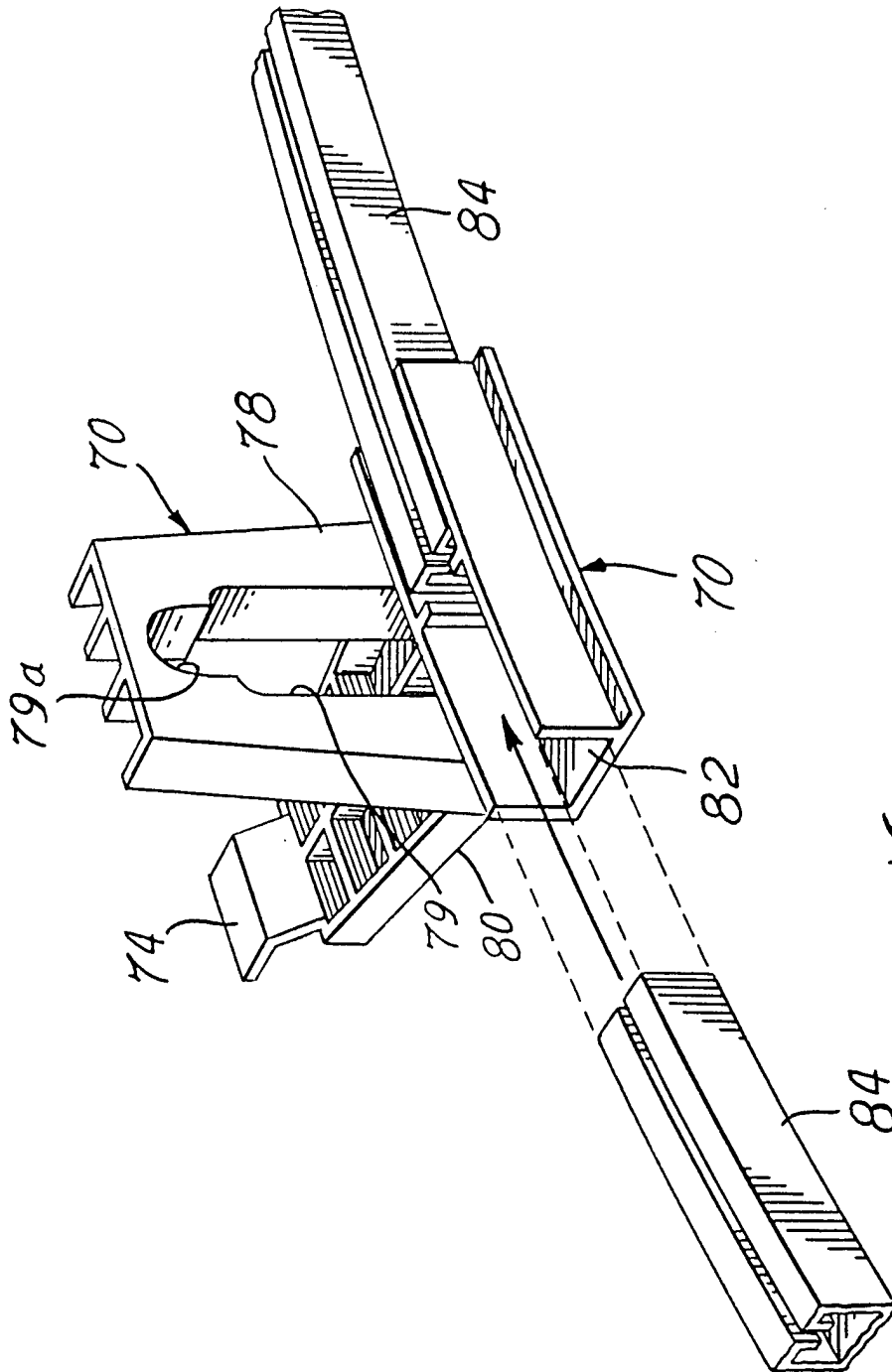

Fig. 10

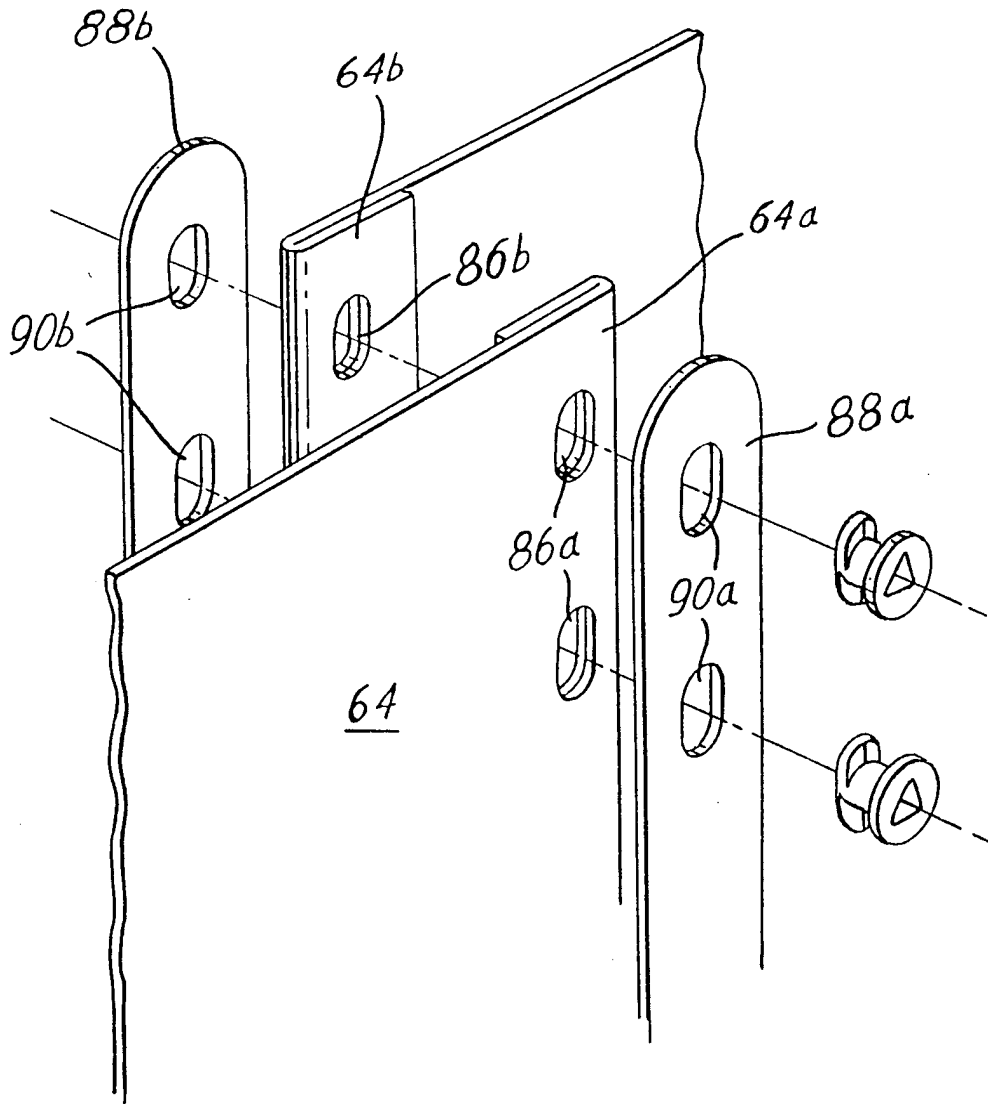

Fig. 11

INTERNATIONAL SEARCH REPORT

International Application No
PCT/CA 98/00556

A. CLASSIFICATION OF SUBJECT MATTER IPC 6 E04H4/00 F16B21/02		
According to International Patent Classification (IPC) or to both national classification and IPC		
B. FIELDS SEARCHED		
Minimum documentation searched (classification system followed by classification symbols) IPC 6 E04H F16B		
Documentation searched other than minimum documentation to the extent that such documents are included in the fields searched		
Electronic data base consulted during the international search (name of data base and, where practical, search terms used)		
C. DOCUMENTS CONSIDERED TO BE RELEVANT		
Category	Citation of document, with indication, where appropriate, of the relevant passages	Relevant to claim No.
X Y	WO 91 09192 A (VOGUE IND LTD) 27 June 1991 see page 5, line 24 - page 6, line 25 see page 9, line 4 - page 10, line 7 see figures 1-5,8,9 ---	1,4,5,9 2
Y X	US 3 785 421 A (LAUNAY P) 15 January 1974 see the whole document ---	2 6-8
A	US 3 974 605 A (BEATTY GORDON WESLEY ET AL) 17 August 1976 see column 4, line 1 - line 56 see column 6, line 46 - line 58 see figures 1-5 -----	1,4,5,9
<input type="checkbox"/> Further documents are listed in the continuation of box C.		
<input checked="" type="checkbox"/> Patent family members are listed in annex.		
° Special categories of cited documents :		
"A" document defining the general state of the art which is not considered to be of particular relevance	"T" later document published after the international filing date or priority date and not in conflict with the application but cited to understand the principle or theory underlying the invention	
"E" earlier document but published on or after the international filing date	"X" document of particular relevance: the claimed invention cannot be considered novel or cannot be considered to involve an inventive step when the document is taken alone	
"L" document which may throw doubts on priority claim(s) or which is cited to establish the publication date of another citation or other special reason (as specified)	"Y" document of particular relevance: the claimed invention cannot be considered to involve an inventive step when the document is combined with one or more other such documents, such combination being obvious to a person skilled in the art.	
"O" document referring to an oral disclosure, use, exhibition or other means	"&" document member of the same patent family	
"P" document published prior to the international filing date but later than the priority date claimed		
Date of the actual completion of the international search <div style="text-align: center; font-size: 1.2em;">7 September 1998</div>	Date of mailing of the international search report <div style="text-align: center; font-size: 1.2em;">14/09/1998</div>	
Name and mailing address of the ISA European Patent Office, P.B. 5818 Patentlaan 2 NL - 2280 HV Rijswijk Tel. (+31-70) 340-2040, Tx. 31 651 epo nl, Fax: (+31-70) 340-3016	Authorized officer <div style="text-align: center; font-size: 1.2em;">Vrugt, S</div>	

INTERNATIONAL SEARCH REPORT

Information on patent family members

International Application No

PCT/CA 98/00556

Patent document cited in search report		Publication date	Patent family member(s)	Publication date
WO 9109192	A	27-06-1991	US 5054135 A	08-10-1991
			AT 127192 T	15-09-1995
			CA 2070777 A	16-06-1991
			DE 69022067 D	05-10-1995
			DE 69022067 T	22-02-1996
			EP 0505411 A	30-09-1992

US 3785421	A	15-01-1974	FR 2135463 A	22-12-1972
			DE 2220609 A	09-11-1972
			GB 1331916 A	26-09-1973

US 3974605	A	17-08-1976	CA 1002703 A	04-01-1977
			JP 51102214 A	09-09-1976
