



US 20050017045A1

(19) **United States**

(12) **Patent Application Publication**  
Beville

(10) **Pub. No.: US 2005/0017045 A1**

(43) **Pub. Date: Jan. 27, 2005**

(54) **APPARATUS AND METHOD TO INDICATE  
REQUIRED COMPRESSOR PRESSURE FOR  
USE WITH PNEUMATIC TOOL DEVICE**

(60) Provisional application No. 60/422,378, filed on Oct. 30, 2002.

**Publication Classification**

(76) Inventor: **John M. Beville**, Jackson, TN (US)

(51) **Int. Cl.<sup>7</sup> .....** B27F 7/17

(52) **U.S. Cl. ....** 227/2; 227/8

Correspondence Address:  
**SUITER WEST PC LLO**  
14301 FNB PARKWAY  
SUITE 220  
OMAHA, NE 68154 (US)

(57) **ABSTRACT**

(21) Appl. No.: **10/894,871**

An apparatus which enables a user of a pneumatic tool device, such as a nail gun, to determine the required compressor pressure needed to most effectively utilize the pneumatic tool device and maximize the life of the tool. A compressor pressure indication assembly on a nail gun comprising a nail verification assembly and a readout assembly enables a user to verify the length and/or diameter of the nails to be driven by the nail gun and set the compressor pressure accordingly.

(22) Filed: **Jul. 20, 2004**

**Related U.S. Application Data**

(63) Continuation-in-part of application No. 10/643,040, filed on Aug. 18, 2003.

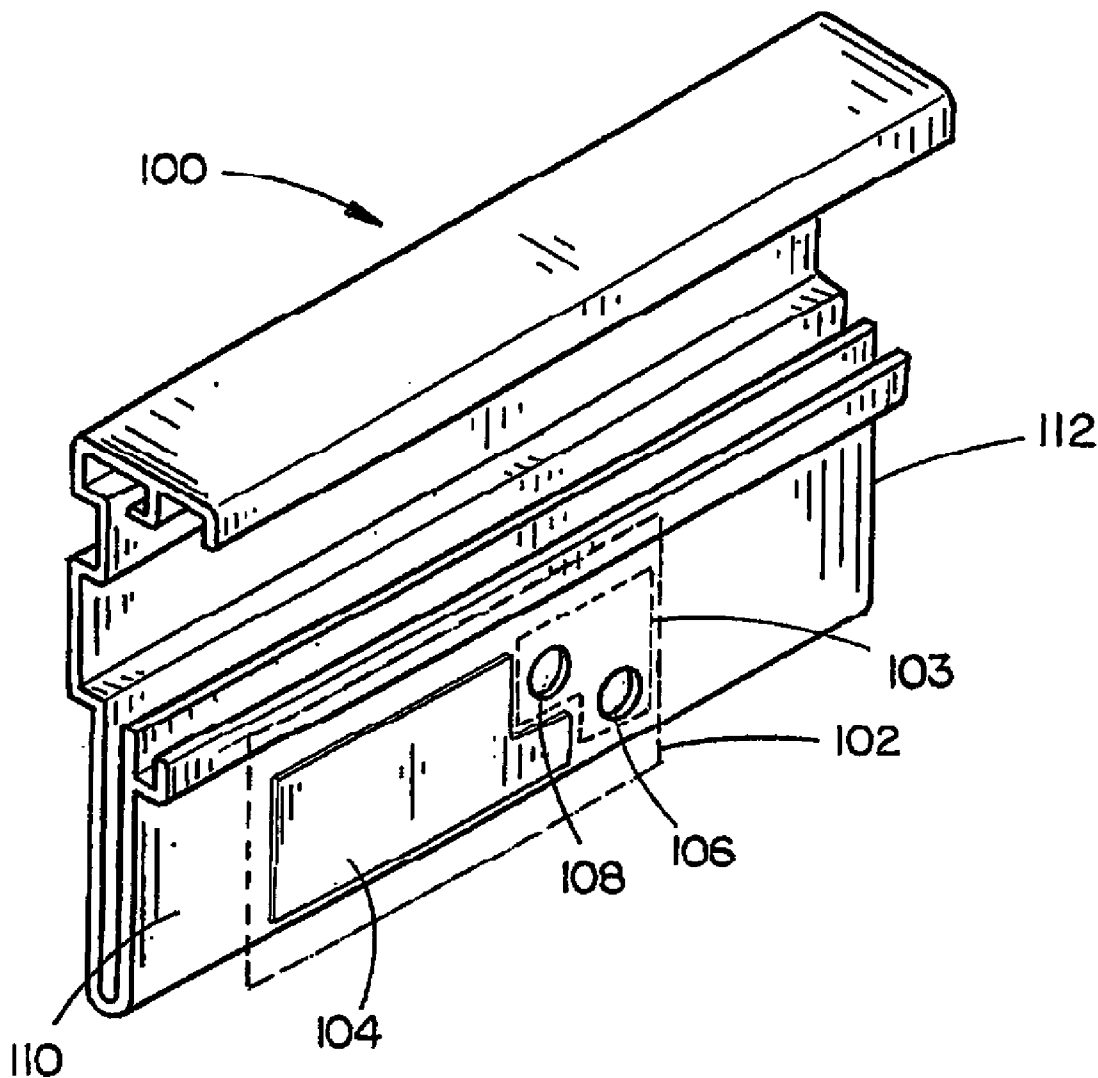

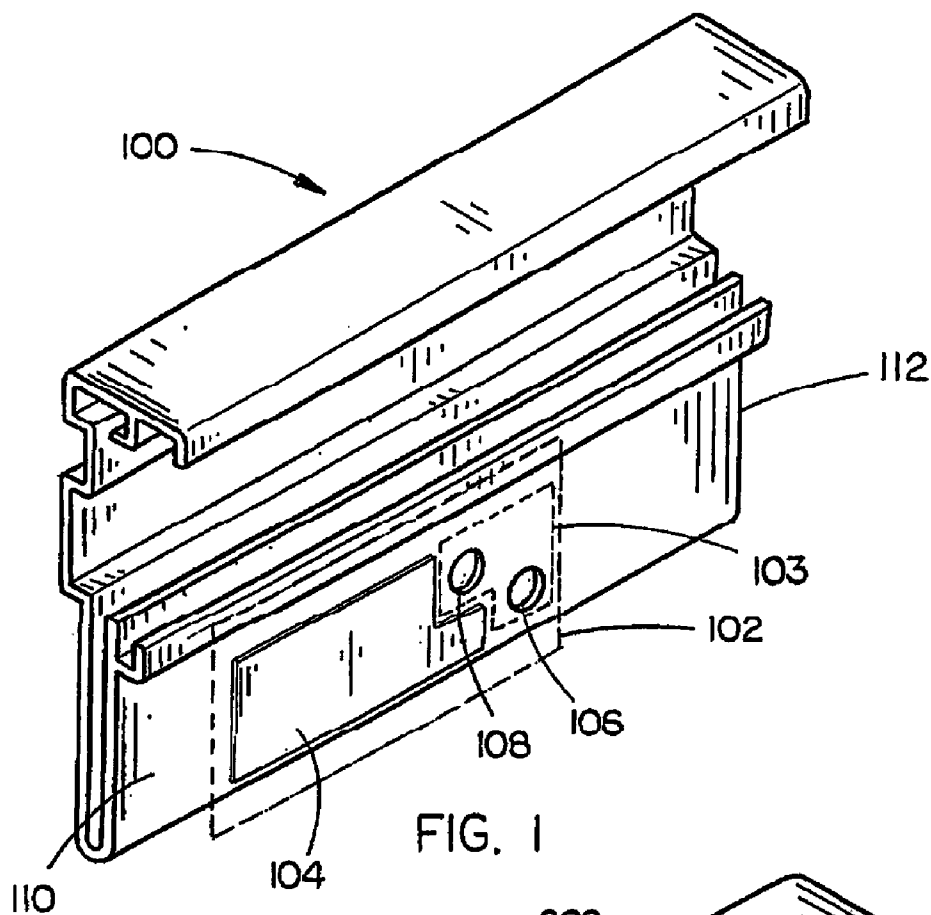

FIG. 1

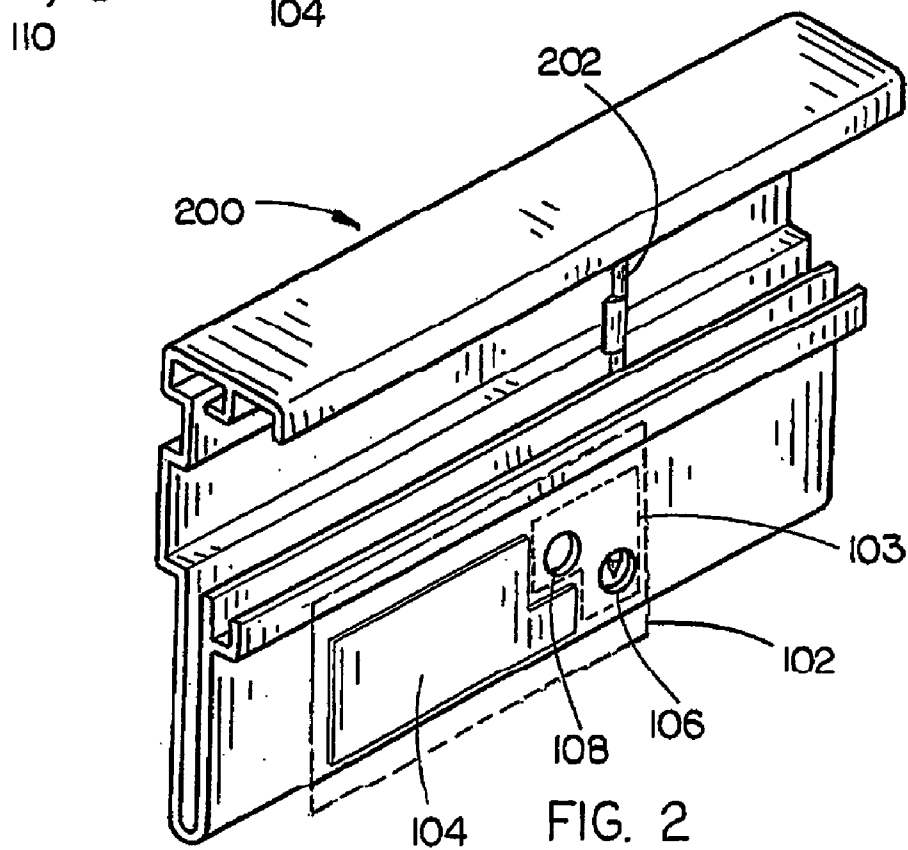
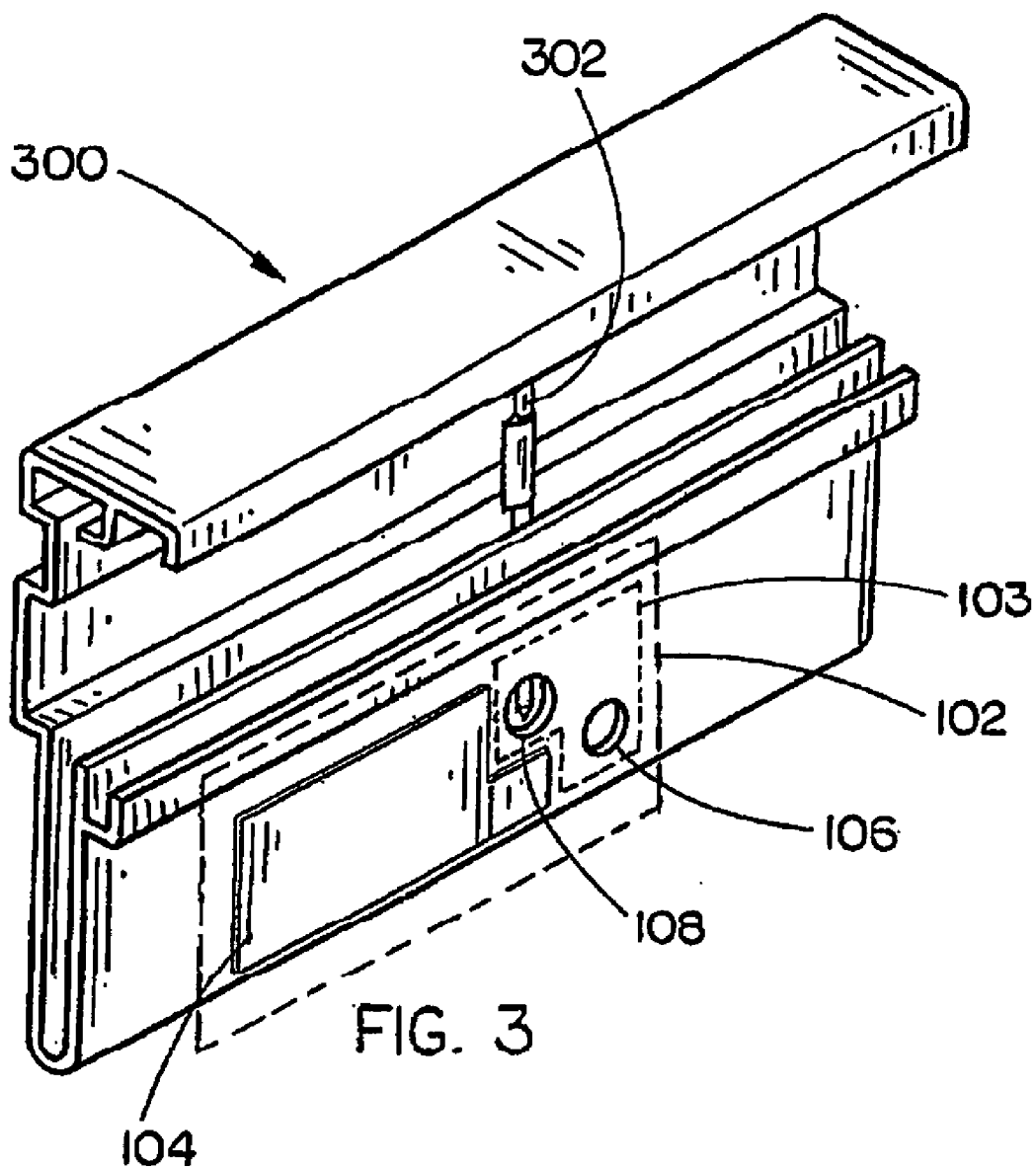

FIG. 2



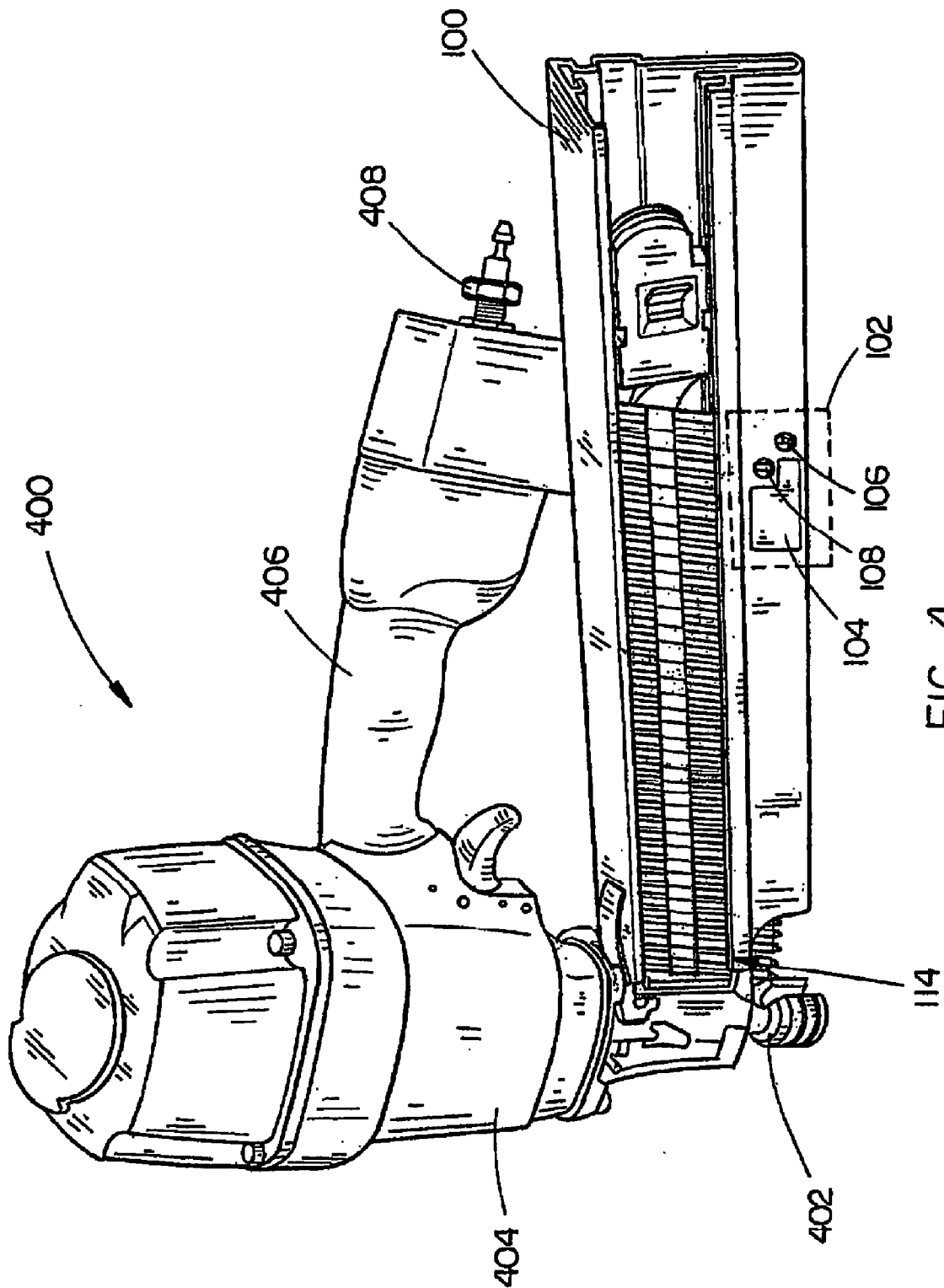

FIG. 4

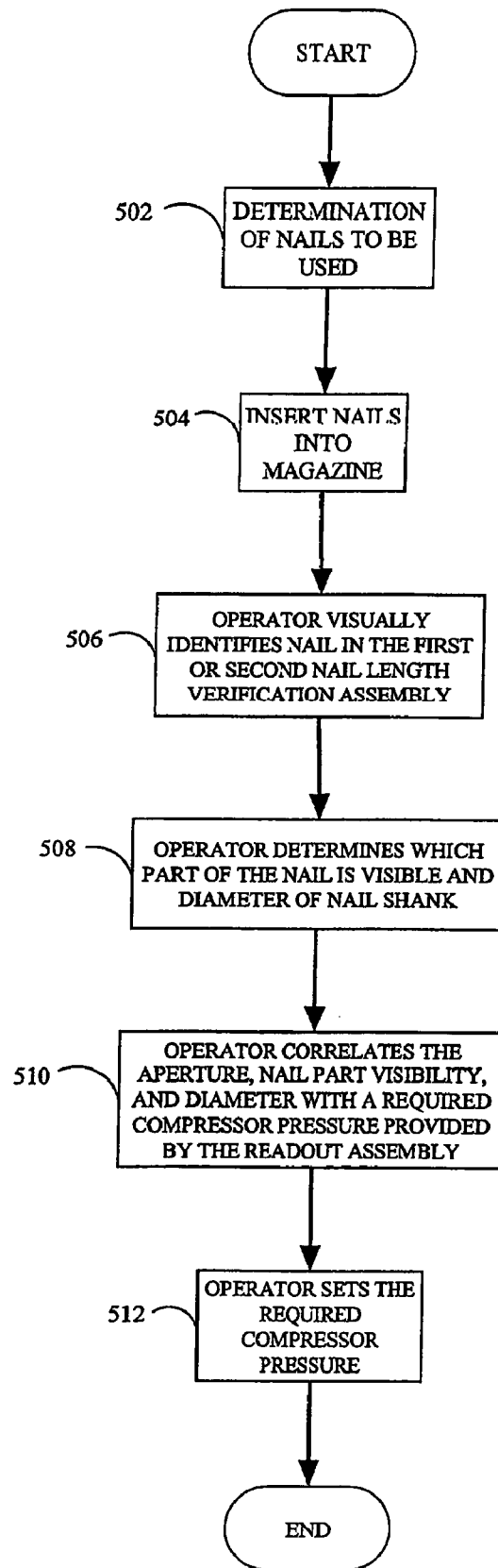
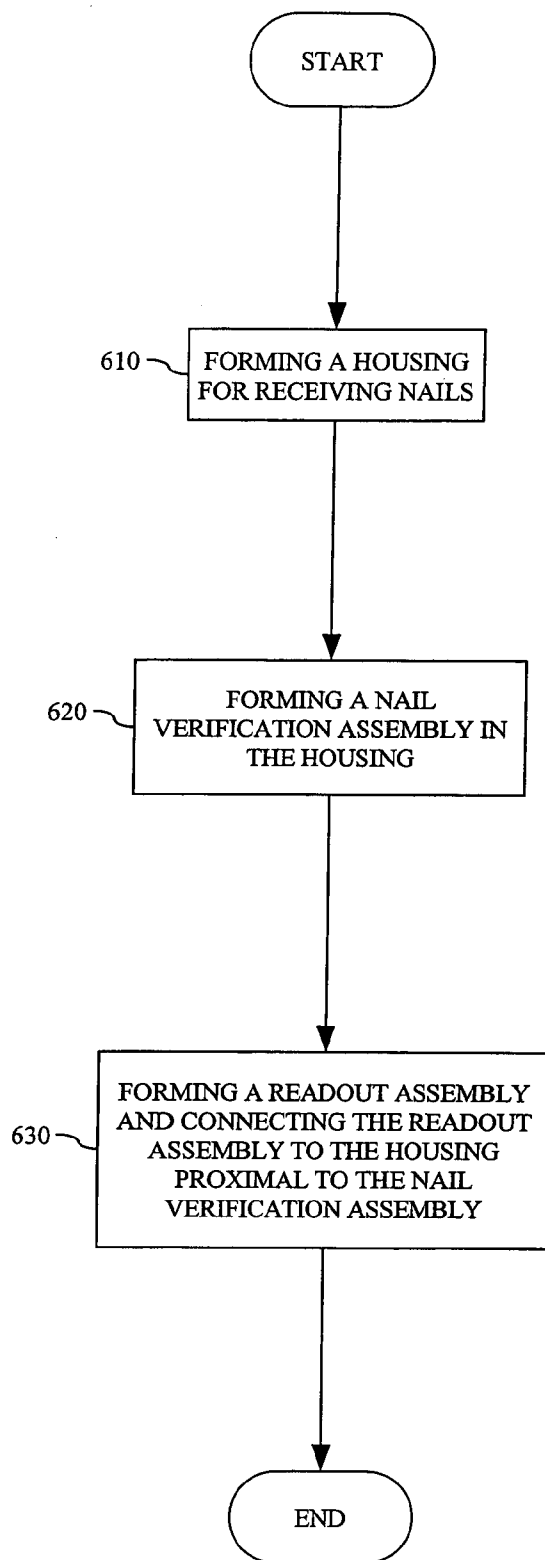
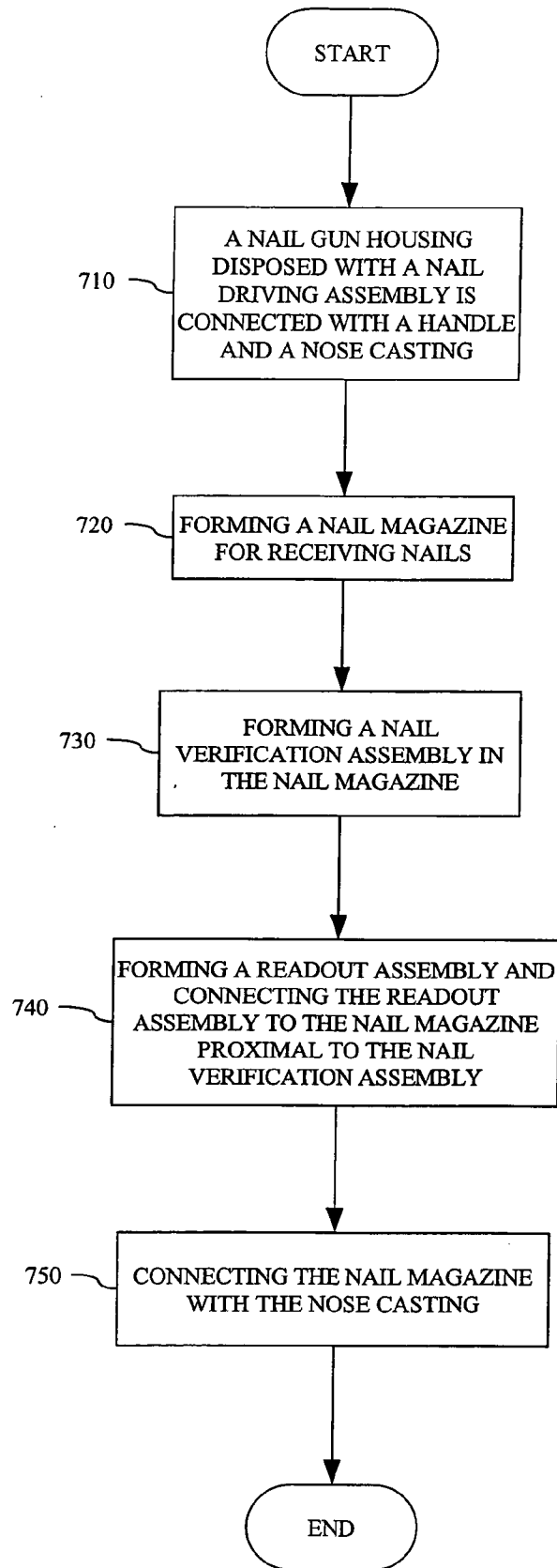

FIG. 5



**FIG. 6**



**FIG. 7**

**APPARATUS AND METHOD TO INDICATE  
REQUIRED COMPRESSOR PRESSURE FOR USE  
WITH PNEUMATIC TOOL DEVICE**

**CROSS REFERENCE TO RELATED  
APPLICATION**

[0001] The present application claims priority under 35 U.S.C. §120 as a continuation-in-part to the U.S. patent application Ser. No. 10/643,040, filed on Aug. 18, 2003, which claimed priority under 35 U.S.C. §119(e) to the U.S. Provisional Patent Application Ser. No. 60/422,378, filed on Oct. 30, 2002. Both U.S. application Ser. Nos. 10/643,040 and 60/422,378 are herein incorporated by reference in their entireties.

**FIELD OF THE INVENTION**

[0002] The present invention generally relates to the field of pneumatic tool devices, and particularly to an apparatus and method for indicating the required compressor pressure to be used when operating a pneumatic tool, such as a pneumatic nail gun.

**BACKGROUND OF THE INVENTION**

[0003] The use of air driven tools is commonplace in a variety of construction situations. Pneumatic nail guns have greatly increased efficiency and productivity on construction worksites. However, nail guns which employ air pressure (pneumatic nail guns) to drive nails have a limited life span due to the high pressures involved in their use. This may result in inefficient tool functionality which may increase labor time and construction costs. Further, this limited life span may result in lost time when the tool must be replaced.

[0004] Unfortunately, there is little in the way of help to a user of these pneumatic nail guns for avoiding shortening the life span of the nail gun due to improper compressor pressure use. For example, nails may have varying lengths and widths. To effectively drive one nail may require a different compressor pressure than that required to effectively drive another. If the user is unaware of the difference in the nails then the compressor pressure will not be adjusted to maximize tool effectiveness. This may result in increased wear on the tool which will shorten its useful life. While it is known to provide a system of adjusting compressor pressure in correlation with nail size when the user is aware of the nail size, there is no protection against the unaware user or the user of a nail gun when the nails have been previously loaded into the nail gun and the user is unable to determine the nail size. In these situations use of the nail gun may significantly decrease the useful life of the nail gun.

[0005] Therefore, it would be desirable to provide a way to maximize the useful life of a pneumatic device, such as a pneumatic nail gun, while ensuring effective nail gun use.

**SUMMARY OF THE INVENTION**

[0006] Accordingly, the present invention is directed to an apparatus and method of indicating the required compressor pressure for use with a pneumatic nail gun. In a first aspect of the present invention, a compressor pressure indication assembly for a pneumatic nail gun having a nail loading assembly comprises a nail verification assembly disposed on the nail loading assembly for identifying the length of a nail received in the nail loading assembly. A remote readout

assembly is associated with the nail verification assembly and provides information to an operator of the pneumatic nail gun. Wherein, the compressor pressure indication assembly indicates the required compressor pressure when using the pneumatic nail gun.

[0007] In a second aspect of the present invention, a compressor pressure indication assembly for a pneumatic nail gun having a nail loading assembly comprises a nail verification assembly disposed on the nail loading assembly for identifying the diameter of a nail received in the nail loading assembly. A remote readout assembly is associated with the nail verification assembly and provides information to an operator of the pneumatic nail gun. Wherein, the compressor pressure indication assembly indicates the required compressor pressure when using the pneumatic nail gun.

[0008] In a third aspect of the present invention, a compressor pressure indication assembly for a pneumatic nail gun having a nail loading assembly comprises a nail verification assembly disposed on the nail loading assembly for identifying the length and diameter of a nail received in the nail loading assembly. A remote readout assembly is associated with the nail verification assembly and provides information to an operator of the pneumatic nail gun. Wherein, the compressor pressure indication assembly indicates the required compressor pressure when using the pneumatic nail gun.

[0009] In a fourth aspect of the present invention, a nail loading assembly for a pneumatic nail gun coupled with a compressor comprises a housing coupled with a compressor pressure indication assembly. The compressor pressure indication assembly, including a remote readout assembly, for identifying the length and diameter of the nail stored in the housing and indicating the required compressor pressure for use with the pneumatic nail gun based on the identified nail length and diameter.

[0010] In a fifth aspect of the present invention, a pneumatic nail gun assembly comprises a housing disposed with a handle, the handle being coupled with a compressor. Further, the pneumatic nail gun assembly comprises a nail driving assembly coupled with the housing, the nail driving assembly being suitable for driving a nail. Additionally, a nail loading assembly is coupled with the nail driving assembly, the nail loading assembly being suitable for storing the nail and providing the nail to the nail driving assembly. A compressor pressure indication assembly, including a remote readout assembly, is disposed on the nail loading assembly, the compressor pressure indication assembly being suitable for identifying the length and diameter of the nail stored in the nail loading assembly. Thus, the compressor pressure indication assembly indicates the required compressor pressure when using the pneumatic nail gun assembly based on the identified length and diameter of the nail.

[0011] In a sixth aspect a method for manufacturing a compressor pressure indication assembly is provided. The manufacturing process including the step of constructing a housing for receiving nails. After the housing is constructed, a nail verification assembly is formed in the housing. A readout assembly is formed and connected to the housing proximal to the location of the nail verification assembly.

[0012] In a seventh aspect a method for manufacturing a pneumatic nail gun is provided. The manufacturing process



including the step of constructing a nail gun housing disposed with a nail driving assembly and connected with a handle and nose casting. A nail magazine is then constructed, the nail magazine for receiving nails. The nail verification assembly is then formed on the nail magazine. A readout assembly is then formed on the nail magazine proximal to the location of the nail verification assembly. In the final step the nail magazine is connected with the nose casting.

[0013] It is to be understood that both the forgoing general description and the following detailed description are exemplary and explanatory only and are not restrictive of the invention as claimed. The accompanying drawings, which are incorporated in and constitute a part of the specification, illustrate an embodiment of the invention and together with the general description, serve to explain the principles of the invention.

#### BRIEF DESCRIPTION OF THE DRAWINGS

[0014] The numerous advantages of the present invention may be better understood by those skilled in the art by reference to the accompanying figures in which:

[0015] **FIG. 1** is a partial isometric view of the nail magazine of a pneumatic nail gun, illustrating a compressor pressure indication assembly in accordance with an exemplary embodiment of the present invention;

[0016] **FIG. 2** is an illustration of the compressor pressure indication assembly engaged with a nail in a first nail inspection station and a readout assembly indicating a first required compressor pressure;

[0017] **FIG. 3** is an illustration of the compressor pressure indication assembly engaged with a nail in a second nail inspection station and the readout assembly indicating a second required compressor pressure;

[0018] **FIG. 4** is an isometric view of a pneumatic nail gun including the compressor pressure indication assembly in accordance with an exemplary embodiment of the present invention;

[0019] **FIG. 5** is a flowchart illustrating a method for indicating the required compressor pressure when using a nail gun coupled with a compressor;

[0020] **FIG. 6** is a block diagram illustrating a method of manufacturing a compressor pressure indication assembly in accordance with an exemplary embodiment of the present invention; and

[0021] **FIG. 7** is a block diagram illustrating a method of manufacturing a pneumatic nail gun in accordance with an exemplary embodiment of the present invention.

#### DETAILED DESCRIPTION OF THE INVENTION

[0022] Reference will now be made in detail to the presently preferred embodiments of the invention, examples of which are illustrated in the accompanying drawings.

[0023] Referring generally now to **FIGS. 1 through 7**, exemplary embodiments of the present invention are shown. The present invention increases the effectiveness and useful life of a pneumatic nail gun through indication of proper compressor pressure correlated to the specific instrument

being operated upon by the tool. An operator of the present invention is assured of an accurate indication of correct compressor pressure without requiring the user to remove already loaded instruments (e.g., a nail magazine) from the pneumatic tool. The present invention is utilized with many differently configured compressors which provide a pressurized gas, such as air, at varying pressures. It is contemplated that the present invention may be used with compressors that provide pressures ranging up to one hundred twenty-five (125) psi (pounds per square inch). Further, the present invention may be used with compressors that provide pressures greater than one hundred twenty-five (125) psi.

[0024] In a preferred embodiment, shown in **FIG. 1**, a housing **100** is provided with a compressor pressure indication assembly **102** in accordance with the present invention. The compressor pressure indication assembly **102** includes a readout assembly **104** and a nail verification assembly **103**. Preferably, the nail verification assembly **103** comprises a first nail inspection station **106** and a second nail inspection station **108**. The first and second nail inspection stations **106** and **108** are disposed on a first side **110** of a housing **100**, proximally located towards a first end **112** of the housing **100**. The first end **112** allows for the loading of nails into the housing **100**.

[0025] In the current embodiment, the first and second nail inspection station **106** and **108** allow visual identification of the nail loaded into the housing. The visual identification of the nail in the first and second nail inspection stations **106** and **108** provide a visual method of nail length and nail shank diameter identification. Preferably, the first and second nail inspection station **106** and **108** are a first and second aperture. Alternatively, the first and second inspection station **106** and **108** may comprise a horizontally aligned slot or a vertically aligned slot. It is contemplated that other systems and methods of identifying nail length within the housing **100** may be employed, such as electrical sensor systems, optical sensor systems, and the like. It is further contemplated that, in alternative embodiments, the first and second nail inspection station **106** and **108** may allow visual identification of only the nail length or nail shank diameter.

[0026] The size of the first and second nail inspection stations **106** and **108** are of a suitable dimension to allow for the visual identification of the position of the nail relative to the aperture. This, in turn, allows for the identification of the length and diameter of the nail being placed into the housing **100**. Preferably, aperture diameters may vary from one-sixteenth of an inch to one-half an inch. In the exemplary embodiment the aperture diameter is one-eighth of an inch. It is understood that the aperture diameter is not limited by the example and ranges stated here but may be smaller than or greater than the stated diameter sizes without departing from the scope and spirit of the present invention. Further, in the present embodiment the first and second nail inspection stations **106** and **108** are only provided in the first side **110**. Alternatively, the first and second nail inspection stations **106** and **108** may be located on a second side of the housing **100**, or the apertures may be disposed on both the first and second side of the housing.

[0027] In the current embodiment, the first nail inspection station **106** is located closer to the first end **112**, relative to the second nail inspection station **108**. The second nail inspection station **108** is spaced apart from the first nail

inspection station **106** to allow for the second nail inspection station **108** to provide an independent identification of the nail. Further, the second nail inspection station **108** is positioned at an angle relative to the first nail inspection station **106**. The angle of positioning of the second nail inspection station **108** may provide an advantage to a user of the present invention if the nails being used are not of sufficient length to be viewed in the first nail inspection station **106**. The amount of spacing between and relative angle of the first and second nail inspection station **106** and **108** may be varied as contemplated by one of ordinary skill in the art.

[0028] Alternatively, the nail verification assembly **103** may comprise a single nail inspection station disposed in the housing **100**. The single nail inspection station may be of sufficient length and size to ascertain the length and diameter of a variety of nail configurations. It is contemplated that the nail inspection station may employ three or more apertures to provide verification of nail length and diameter for ascertainment of appropriate compressor pressure. It is further contemplated that the nail inspection station, whether employing one, two, three or more apertures, may include nail length markers and nail diameter markers proximally disposed about the aperture(s). The nail length and diameter markers may comprise a line mark next to an aperture so that the tip and outside edges of the nail observed in the aperture correlates to the line mark, which in turn indicates to an operator the required compressor pressure.

[0029] In the preferred embodiment, the readout assembly **104** is a label, which contains printed terms identifying the required compressor pressure in correlation to the nail length and the nail shank diameter identified by the first and second nail inspection stations **106** and **108**. For example, the chart may contain short phrases, such as "tip of nail visible", "shank of nail visible", "diameter of nail outside markings", or "diameter of nail inside markings," and then have the corresponding compressor pressures indicated. It is understood that the readout assembly **104** may indicate a range of compressor pressures suitable for use with a particular nail length and/or diameter. Alternatively, the readout assembly **104** may be a chart, which on one side identifies the nail length and/or diameter and on the other side gives the corresponding compressor pressure. It is further contemplated that the readout assembly **104** may provide an indication of required compressor pressure based only on the identified nail length or based only on the identified diameter of the nail shank.

[0030] In the present embodiment, the readout assembly **104** is located proximally to the first and second nail inspection stations **106** and **108**. Alternatively, the location of the readout assembly **104** may be varied. For instance, the readout assembly **104** may be disposed at various locations along the housing **100**, not necessarily proximal to the nail inspection station. It is contemplated that the readout assembly **104** may be disposed in various locations upon a nail gun which is employing the compressor pressure indication assembly **102** of the present invention. For example, a section of the handle of the nail gun may be disposed with the readout assembly **104** or on a nail driving assembly housing of the nail gun.

[0031] It is further contemplated that the readout assembly **104** is a remote readout assembly disposed upon an object or

surface, which is not the housing **102** or the nail gun as described above. For example, the readout assembly **104** may be contained within the pages of an instruction manual for the operation of a device with which the compressor pressure indication assembly **102** is being utilized. Alternatively, the readout assembly **104** may be disposed upon a casing within which is stored a device with which the compressor pressure indication assembly **102** is being utilized. For example, a nail gun may be sold in a casing upon which the readout assembly **104** is disposed.

[0032] In the current embodiment, the readout assembly **104** is an "L" shaped label adhered to the first side **110** of the housing **100**. It is understood that the shape of the readout assembly **104** may vary as contemplated by one of ordinary skill in the art. The adhering may be accomplished by numerous methods, such as, glue, tape, and the like. It is contemplated that the readout assembly **104** may be positioned on the housing **100** by a variety of methods. For example, the readout assembly **104** may be engraved on the first side **110** of the housing **100**. Alternatively, the readout assembly **104** may be magnetically attached to the housing **100**. It is understood that the readout assembly **104** may be a removable assembly, thereby, being enabled for use with multiple housing structures.

[0033] It is contemplated that the readout assembly **104** and the remote readout assembly described above, may be an information handling system which is enabled to provide correlation of the nail length identified with a required compressor pressure. For example, an operator of the compressor pressure indication assembly **102** first identifies the nail length and/or diameter through use of the nail verification assembly **103**. The operator then enters the information into the readout assembly **104**, which processes the information to determine the necessary compressor pressure. The readout assembly **104** may further comprise a display. The display provides a visual readout of relevant information to the operator such as the required compressor pressure setting correlating to the nail length and/or diameter information entered by the operator. The readout assembly may provide a range of compressor pressures suitable for use with the identified nail length and/or diameter and display that range on the display.

[0034] As an information handling system, the readout assembly **104** may be a computing system enabled with computing functionality. For example, the readout assembly **104** may be enabled to allow an operator to perform calculations or store relevant information. Additionally, the readout assembly **104** may be enabled to communicatively link with peripheral computing devices. Such communicative linkage may be established using a variety of methods, such as serial cable, infrared, radio frequency, and the like. The communicative linkages may form a network which may download information into a central computing system, which information may then be reviewed by an operator. This may be advantageous at a worksite as a supervisor may be able to track the type and number of nails being used by the operators of the nail guns linked into the network.

[0035] Referring now to FIG. 2, the compressor pressure indication assembly **102** is shown disposed on a nail loading assembly **200** and engaged with a nail **202**. In FIG. 2, the nail **202** is located in a first position, visible through the first nail inspection station **106**. The part of the nail **202** that is

visible is indicative of the overall nail length which provides the guidance as to the required compressor pressure. The first nail inspection station **106** also provides the user of the compressor pressure indication assembly **102** with the ability to determine the diameter of the nail shank which provides further guidance as to the required compressor pressure. In the present embodiment, the tip of the nail **202** is visible in the first nail inspection station **106**. From this visual indication, the operator of the present invention may then utilize the readout assembly **104** to determine the required compressor pressure or range of compressor pressures within which safe operation may be accomplished. For instance, if the readout assembly **104** uses the phrase "tip of nail visible and nail diameter outside markings" with a corresponding compressor pressure or range of compressor pressures, then the operator, upon visually determining that the tip of the nail is visible and that the nail diameter is outside the markings would set the compressor pressure to that indicated by the readout assembly **104**.

[0036] In **FIG. 3** the compressor pressure indication assembly **102** is shown disposed on a nail loading assembly **300** and engaged with a nail **302**. The nail **302** is located in a second position, visible through the second nail inspection station **108**. In this location it may be seen that the tip of the nail is visible through the second nail inspection station **108**. The second nail inspection station **108** also enables a nail shank diameter determination. From this visible identification, the readout assembly **104** may instruct the operator that a new compressor pressure setting or range of compressor pressures is required from the compressor for use with the current nail. The compressor may be variously enabled, for example, the range of pressures a particular compressor is able to provide may vary. One compressor may be able to provide compressed gases, such as air, up to one hundred (100) psi (pounds per square inch) while another compressor may be able to provide compressed air up to one hundred twenty-five (125) psi. It is to be understood that the compressor pressure indication assembly **102** is able to assist in providing accurate compressor pressure settings or range of compressor pressures for various types of nails when used with a variety of compressors. It is contemplated that the compressors, with which the present invention may be employed, may range in capabilities providing compressed gases, such as air, at pressures lower than one hundred (100) psi or more than one hundred twenty-five (125) psi.

[0037] In the exemplary embodiment shown, the compressor pressure may need to be set to a lower pressure setting as the nail length is shorter than that seen in **FIG. 2**. The diameter of the nail may be the same as that seen in **FIG. 2**, or different from that in **FIG. 2**, requiring adjustment of the compressor pressure based on the new nail shank diameter. It is understood that the readout assembly **104** provides a variety of readings. Thus, when a nail is engaged in the second nail inspection station **108**, the readout assembly **104** may instruct the operator to adjust the pressure setting higher or lower than where it is currently set.

[0038] Referring now to **FIG. 4**, a pneumatic nail gun **400** is shown disposed with the compressor pressure indication assembly **102** including the readout assembly **104**. In the current embodiment, a second end **114** of housing **100** connects with a nose casting **402**. The nose casting **402** is connected to a nail gun casing **404**, the nail gun casing **404** is disposed with a handle **406** and includes a driver blade

assembly for driving the nail presented in the nose casting **402**. The handle **406** is disposed with a connection assembly **408** for connecting with a hose, which connects with an air compressor.

[0039] It is contemplated that the compressor pressure indication assembly **102** may be disposed on an adjustable angle nail gun magazine for use with a pneumatic nail gun. The positioning of the first and second nail inspection stations **106** and **108** on the adjustable angle nail gun magazine may be adjusted to accommodate the multi-position functionality of the adjustable angle nail gun magazine.

[0040] A flowchart illustrating the functional steps accomplished utilizing the present invention is shown in **FIG. 5**. In step **502** an operator determines what nails are to be used during operation of the pneumatic nail gun. Generally, there are two types of nails used with these nail guns, clipped-head and round-head, and both types of nails come in a magazine of multiple nails which are bound together. Depending on which type of nail is chosen, an angle of nail presentation is determined by the collation angle of the nail magazine. In step **504** the operator begins to insert the magazine of nails into the housing. As the magazine is being loaded, in step **506**, the operator visually identifies the nail either within the first nail inspection station **106** or the second nail inspection station **108**. In step **508** the operator determines which part of the nail is visible and the diameter of the nail shank. After determining the aperture through which the nail is viewed, which part of the nail is visible, and the diameter of the nail shank, in step **510** the operator correlates the aperture, nail part visibility, and nail shank diameter with a required compressor pressure provided by the readout assembly. In step **512** the operator sets the compressor pressure to the required pressure and begins operation of the nail gun. This method ensures maximum effectiveness of the nail gun when driving each nail and maximizes the useful life of the nail gun.

[0041] Referring now to **FIG. 6** a block diagram illustrating a method **600** for manufacturing a compressor pressure indication assembly of the present invention is shown. In a first step **610**, a housing is constructed, the housing constructed for receiving nails and being composed of various material of sufficient structural strength. In a preferred embodiment, the housing is constructed as a nail magazine for use with a pneumatic nail gun. It is contemplated that the nail magazine may be constructed as an adjustable angle magazine. In a second step **620** a nail verification assembly is constructed in the housing. The nail verification assembly may be variously configured within the dimensional and structural characteristics as previously described. For instance, the nail verification assembly may be configured with a single nail inspection station or two or more nail inspection stations. After the nail verification assembly is formed, in step **630** a readout assembly is constructed and connected with the housing in a location proximal to the nail verification assembly. The readout assembly may be constructed and configured in any of the various manners as previously described. Additionally, the readout assembly may be configured as an information handling system, such as a computing system, as previously described.

[0042] In **FIG. 7** a method **700** of manufacturing a pneumatic nail gun is provided. In a first step **710** a nail gun

housing is constructed, the nail gun housing being disposed with a nail driving assembly and connected with a handle and nose casting. In step 720 a nail magazine, for receiving nails, is constructed to connect with the nose casting. In step 730 a nail verification assembly is constructed in the nail magazine. The nail verification assembly may be constructed and configured in various manners, such as that described previously. In step 740 a readout assembly, constructed and configured in various manners as previously described, is constructed and connected with the nail magazine in a position proximal to the location of the nail verification assembly. In step 750 the nail magazine is connected with the nose casting.

[0043] It is contemplated that the nail magazine formed for use on the pneumatic nail gun may be variously configured. It is further contemplated that the pneumatic nail gun may couple with various compressor assemblies, which provide various pressures of compressed gases, such as air. The pressures of the various compressor assemblies preferably range up to and include one hundred twenty-five (125) psi. Higher compressor pressures may also be utilized in conjunction with the pneumatic nail gun of the present invention.

[0044] In the exemplary embodiments, the methods disclosed may be implemented as sets of instructions or software readable by a device. Further, it is understood that the specific order or hierarchy of steps in the methods disclosed are examples of exemplary approaches. Based upon design preferences, it is understood that the specific order or hierarchy of steps in the method may be rearranged while remaining within the scope and spirit of the present invention. The accompanying method claims present elements of the various steps in a sample order, and are not necessarily meant to be limited to the specific order or hierarchy presented.

[0045] It is believed that the apparatus and method to indicate required compressor pressure to a user of a nail gun of the present invention and many of its attendant advantages will be understood by the forgoing description. It is also believed that it will be apparent that various changes may be made in the form, construction and arrangement of the components thereof without departing from the scope and spirit of the invention or without sacrificing all of its material advantages. The form herein before described being merely an explanatory embodiment thereof. It is the intention of the following claims to encompass and include such changes.

What is claimed is:

1. A compressor pressure indication assembly for a pneumatic nail gun having a nail loading assembly, comprising:

a nail verification assembly disposed in the nail loading assembly of the pneumatic nail gun, the nail verification assembly provides indication of the length of a nail received in the nail loading assembly; and

a remote readout assembly associated with the nail verification assembly, the remote readout assembly providing a display of information,

wherein the compressor pressure indication assembly indicates the required compressor pressure when using the pneumatic nail gun.

2. The compressor pressure indication assembly of claim 1, wherein the nail loading assembly is a nail gun magazine.

3. The compressor pressure indication assembly of claim 1, wherein the nail verification assembly comprises a nail inspection station disposed in the nail loading assembly of the pneumatic nail gun.

4. The compressor pressure indication assembly of claim 3, wherein the nail inspection station is selected from the group consisting of an aperture, a horizontally aligned slate, or a vertically aligned slot.

5. The compressor pressure indication assembly of claim 4, wherein the nail verification assembly comprises a first aperture and a second aperture disposed in the nail loading assembly of the pneumatic nail gun.

6. The compressor pressure indication assembly of claim 1, wherein the remote readout assembly is disposed in at least one of a manual and casing of a tool which employs the compressor indication assembly.

7. The compressor pressure indication assembly of claim 1, wherein the remote readout assembly is an information handling system.

8. The compressor pressure indication assembly of claim 1, wherein the remote readout assembly is connected with nail loading assembly.

9. A compressor pressure indication assembly for a pneumatic nail gun having a nail loading assembly, comprising:

a nail verification assembly disposed in the nail loading assembly of the pneumatic nail gun, the nail verification assembly provides indication of a diameter of a nail received in the nail loading assembly; and

a remote readout assembly associated with the nail verification assembly, the remote readout assembly providing a display of information,

wherein the compressor pressure indication assembly indicates the required compressor pressure when using the pneumatic nail gun.

10. The compressor pressure indication assembly of claim 9, wherein the nail loading assembly is a nail gun magazine.

11. The compressor pressure indication assembly of claim 9, wherein the nail verification assembly comprises a nail inspection station disposed in the nail loading assembly of the pneumatic nail gun.

12. The compressor pressure indication assembly of claim 11, wherein the nail inspection station is selected from the group consisting of an aperture, a horizontally aligned slate, or a vertically aligned slot.

13. The compressor pressure indication assembly of claim 12, wherein the nail verification assembly comprises a first aperture and a second aperture disposed in the nail loading assembly of the pneumatic nail gun.

14. The compressor pressure indication assembly of claim 9, wherein the remote readout assembly is disposed in at least one of a manual and casing of a tool which employs the compressor indication assembly.

15. The compressor pressure indication assembly of claim 9, wherein the remote readout assembly is an information handling system.

16. The compressor pressure indication assembly of claim 9, wherein the remote readout assembly is connected with nail loading assembly.

17. A compressor pressure indication assembly for a pneumatic nail gun having a nail loading assembly, comprising:

a nail verification assembly disposed in the nail loading assembly of the pneumatic nail gun, the nail verification assembly provides indication of a length and a diameter of a nail received in the nail loading assembly; and

a remote readout assembly associated with the nail verification assembly, the remote readout assembly providing a display of information,

wherein the compressor pressure indication assembly indicates the required compressor pressure when using the pneumatic nail gun.

**18.** The compressor pressure indication assembly of claim 17, wherein the nail loading assembly is a nail gun magazine.

**19.** The compressor pressure indication assembly of claim 17, wherein the nail verification assembly comprises a nail inspection station disposed in the nail loading assembly of the pneumatic nail gun.

**20.** The compressor pressure indication assembly of claim 19, wherein the nail inspection station is selected from the group consisting of an aperture, a horizontally aligned slate, or a vertically aligned slot.

**21.** The compressor pressure indication assembly of claim 20, wherein the nail verification assembly comprises a first aperture and a second aperture disposed in the nail loading assembly of the pneumatic nail gun.

**22.** The compressor pressure indication assembly of claim 17, wherein the remote readout assembly is disposed in at least one of a manual and casing of a tool which employs the compressor indication assembly.

**23.** The compressor pressure indication assembly of claim 17, wherein the remote readout assembly is an information handling system.

**24.** The compressor pressure indication assembly of claim 17, wherein the remote readout assembly is connected with nail loading assembly.

**25.** A nail loading assembly for a pneumatic nail gun coupled with a compressor, comprising:

a housing for storing a nail and providing the nail to the pneumatic nail gun; and

a compressor pressure indication assembly disposed on the housing, the compressor pressure indication assembly for identifying the length of the nail stored in the housing and including a remote readout assembly,

wherein the compressor pressure indication assembly indicates the required compressor pressure for use with the pneumatic nail gun based on the identified nail length.

**26.** The nail loading assembly of claim 25, wherein the compressor pressure indication assembly further comprises a nail verification assembly for identifying the length of a nail in the nail loading assembly.

**27.** The nail loading assembly of claim 26, wherein the nail verification assembly includes at least one nail inspection station selected from the group consisting of an aperture, a horizontally aligned slate, or a vertically aligned slot.

**28.** The nail loading assembly of claim 27, wherein the nail verification assembly comprises a first aperture and a second aperture disposed in the nail loading assembly of the pneumatic nail gun.

**29.** The nail loading assembly of claim 25, wherein the remote readout assembly is disposed in at least one of a manual and casing of a tool which employs the compressor indication assembly.

**30.** The nail loading assembly of claim 25, wherein the remote readout assembly is an information handling system.

**31.** The nail loading assembly of claim 25, wherein the remote readout assembly is connected with nail loading assembly.

**32.** The nail loading assembly of claim 25, wherein the nail loading assembly is a nail gun magazine.

**33.** A pneumatic nail gun assembly, comprising:

a housing disposed with a handle, the handle being coupled with a compressor;

a nail driving assembly coupled with the housing, the nail driving assembly for driving a nail;

a nail loading assembly coupled with the nail driving assembly, the nail loading assembly for receiving the nail; and

a compressor pressure indication assembly disposed on the nail loading assembly, the compressor pressure indication assembly for identifying the length and diameter of the nail stored in the nail loading assembly and including a remote readout assembly,

wherein the compressor pressure indication assembly indicates the required compressor pressure when using the pneumatic nail gun assembly based on the identified length and diameter of the nail.

**34.** The pneumatic nail gun assembly of claim 33, wherein the compressor pressure indication assembly further comprises a nail verification assembly for identifying the length of a nail in the nail loading assembly.

**35.** The pneumatic nail gun assembly of claim 34, wherein the nail verification assembly includes at least one nail inspection station selected from the group consisting of an aperture, a horizontally aligned slate, or a vertically aligned slot.

**36.** The pneumatic nail gun assembly of claim 35, wherein the nail verification assembly comprises a first aperture and a second aperture disposed in the nail loading assembly of the pneumatic nail gun.

**37.** The pneumatic nail gun assembly of claim 33, wherein the remote readout assembly is disposed in at least one of a manual and casing of a tool which employs the compressor indication assembly.

**38.** The pneumatic nail gun assembly of claim 33, wherein the remote readout assembly is an information handling system.

**39.** The pneumatic nail gun assembly of claim 33, wherein the remote readout assembly is connected with nail loading assembly.

**40.** The pneumatic nail gun assembly of claim 33, wherein the nail loading assembly is a nail gun magazine.

**41.** A method of manufacturing a compressor pressure indication assembly, comprising:

constructing a housing for receiving nails;

constructing a nail verification assembly on the housing; and

constructing a readout assembly and connecting the readout assembly with the housing proximal to the nail verification assembly.

**42.** The method of claim 41, wherein the housing is a nail loading assembly.

**43.** The method of claim 41, wherein the step of constructing the nail verification assembly further includes forming at least one nail inspection station selected from the group consisting of an aperture, a horizontally aligned slate, or a vertically aligned slot.

**44.** The method of claim 43, wherein the nail verification assembly comprises a first aperture and a second aperture disposed in the nail loading assembly of the pneumatic nail gun.

**45.** The method of claim 41, wherein the readout assembly is an information handling system.

**46.** The method of claim 41, wherein the readout assembly is a remote readout assembly.

**47.** The method claim 46, wherein the remote readout assembly is connected with the housing.

**48.** A method of manufacturing a pneumatic nail gun, comprising:

constructing a nail gun housing disposed with a nail driving assembly, the nail gun housing connected with a handle and a nose casting;

constructing a nail magazine for receiving nails;

constructing a nail verification assembly on the nail magazine;

constructing a readout assembly and connecting the readout assembly with the nail magazine proximal to the nail verification assembly; and

connecting the nail magazine with the nose casting.

**49.** The method of claim 48, wherein the step of constructing the nail verification assembly further includes forming at least one nail inspection station selected from the group consisting of an aperture, a horizontally aligned slate, or a vertically aligned slot.

**50.** The method of claim 49, wherein the nail verification assembly comprises a first aperture and a second aperture disposed in the nail loading assembly of the pneumatic nail gun.

**51.** The method of claim 48, wherein the readout assembly is an information handling system.

**52.** The method of claim 48, wherein the readout assembly is a remote readout assembly.

**53.** The method of claim 52, wherein the remote readout assembly is connected with the nail magazine.

\* \* \* \* \*