



US 20210212178A1

(19) **United States**

(12) **Patent Application Publication**
MEIR

(10) **Pub. No.: US 2021/0212178 A1**

(43) **Pub. Date: Jul. 8, 2021**

(54) **ADJUSTABLE WHITE LIGHT ILLUMINATION DEVICES**

F21K 9/68 (2006.01)

F21V 8/00 (2006.01)

(71) Applicant: **Noam MEIR**, Herzeliya (IL)

(52) **U.S. Cl.**

CPC *H05B 45/20* (2020.01); *G02B 6/0073* (2013.01); *F21K 9/68* (2016.08); *F21K 9/64* (2016.08)

(72) Inventor: **Noam MEIR**, Herzeliya (IL)

(21) Appl. No.: **17/146,578**

(22) Filed: **Jan. 12, 2021**

(57) **ABSTRACT**

Related U.S. Application Data

(63) Continuation of application No. 16/750,031, filed on Jan. 23, 2020, now Pat. No. 10,925,134, which is a continuation of application No. 16/425,083, filed on May 29, 2019, now Pat. No. 10,582,586.

(60) Provisional application No. 62/811,551, filed on Feb. 28, 2019, provisional application No. 62/677,405, filed on May 29, 2018.

Publication Classification

(51) **Int. Cl.**

H05B 45/20 (2006.01)

F21K 9/64 (2006.01)

A lighting device producing white light having a target color correlated temperature (CCT) value includes an LED array having one or more red LEDs, one or more warm white LEDs, and one or more cool white LED; one or more photo-luminescent materials for shifting the CCT value of the light emitted from the cool white LED toward a green CCT value and/or the CCT value of the light emitted from the warm white LED toward a yellow CCT value; and a waveguide material having a mixing region for mixing the shifted and unshifted light so as to generate white light having the target CCT value and an output region for outputting the white light.

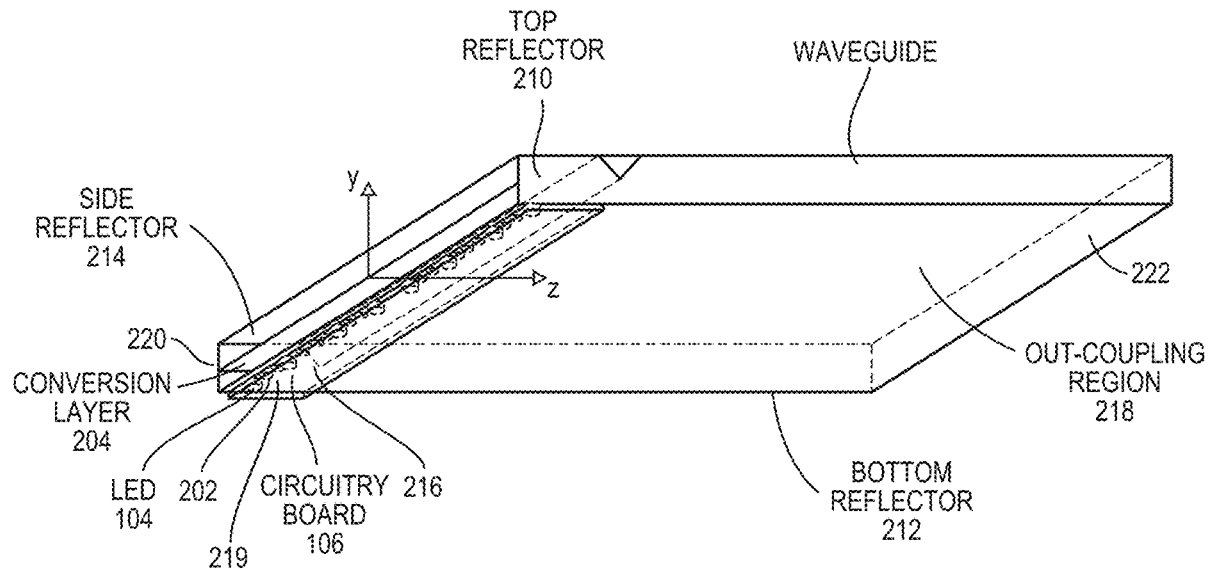

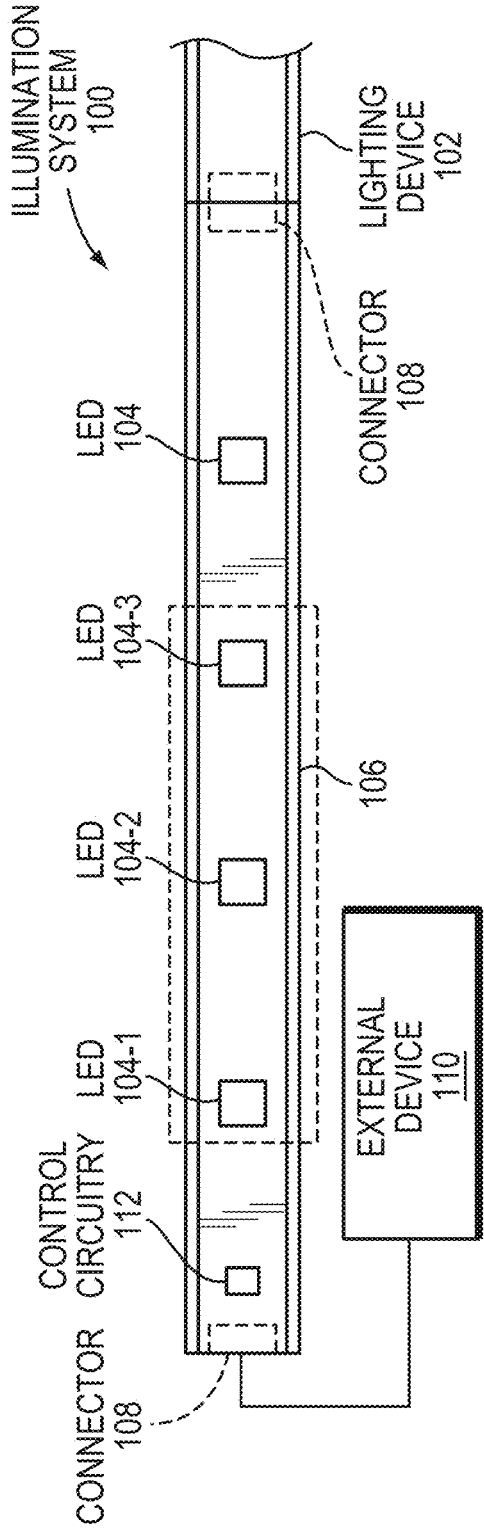

FIG. 1A

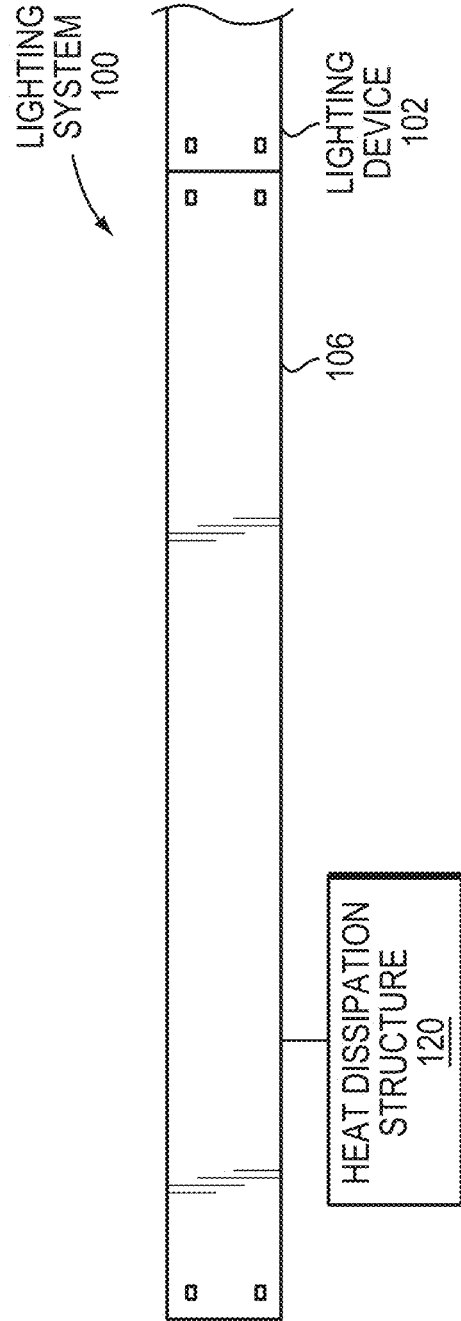

FIG. 1B

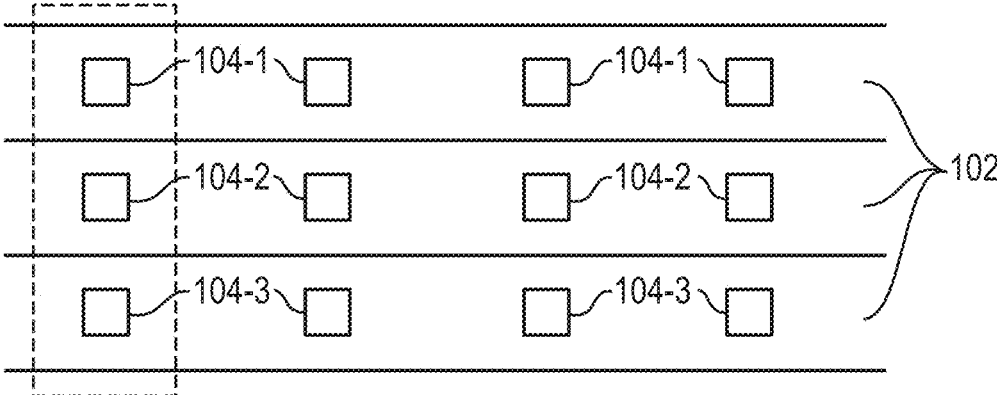

FIG. 1C

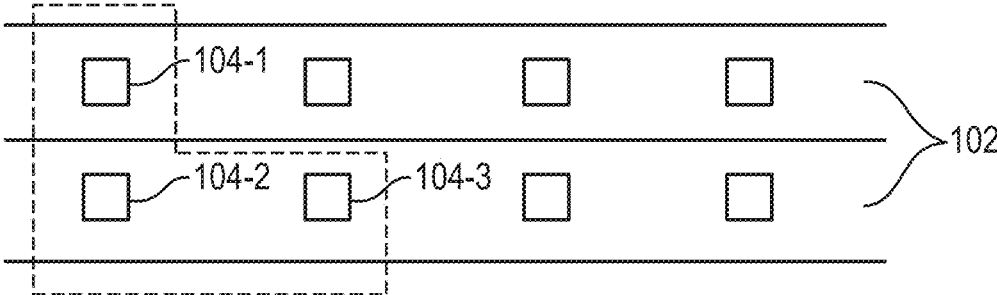

FIG. 1D

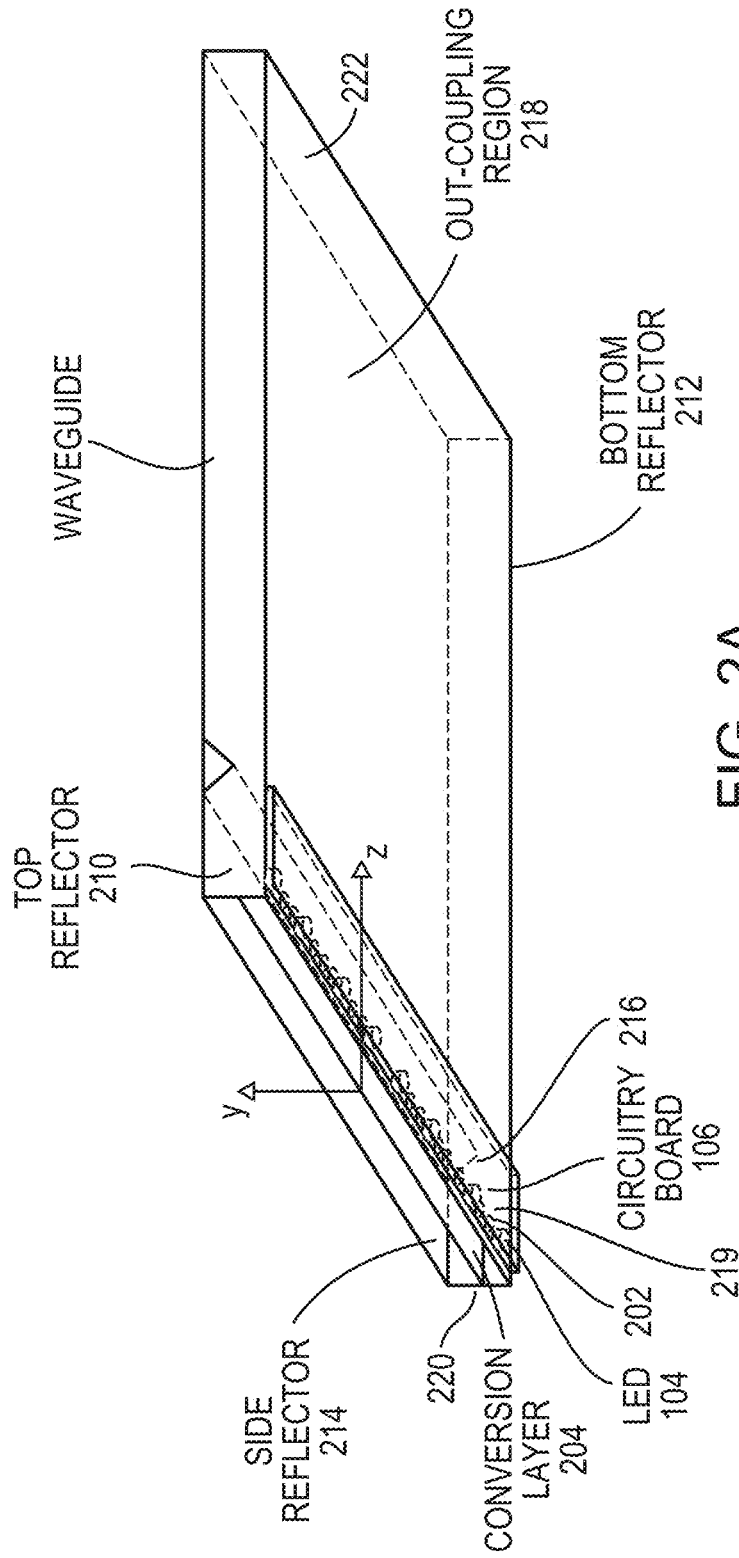

FIG. 2A

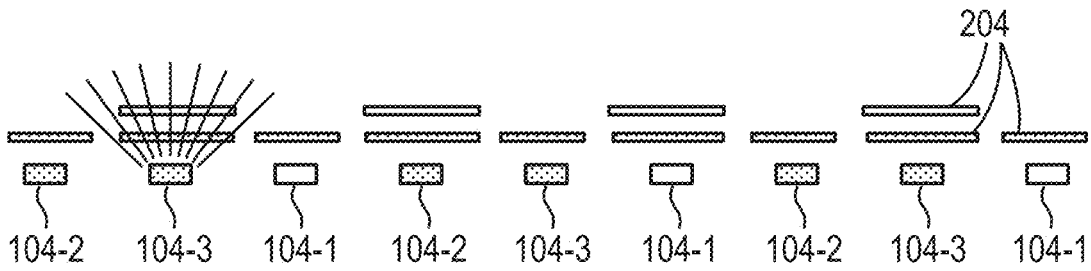

FIG. 2B

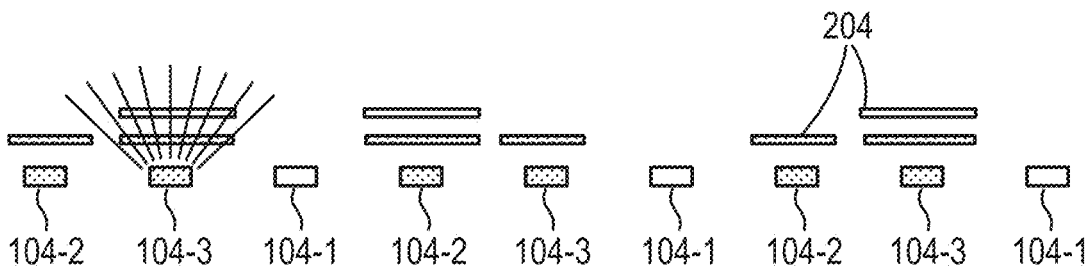

FIG. 2C

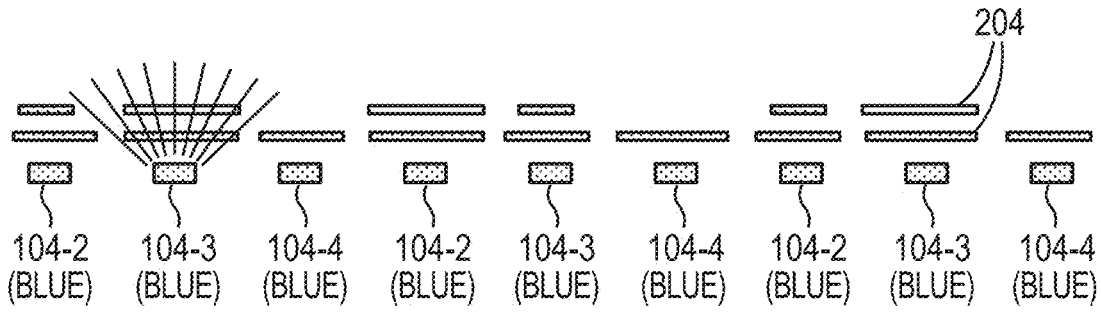

FIG. 2D

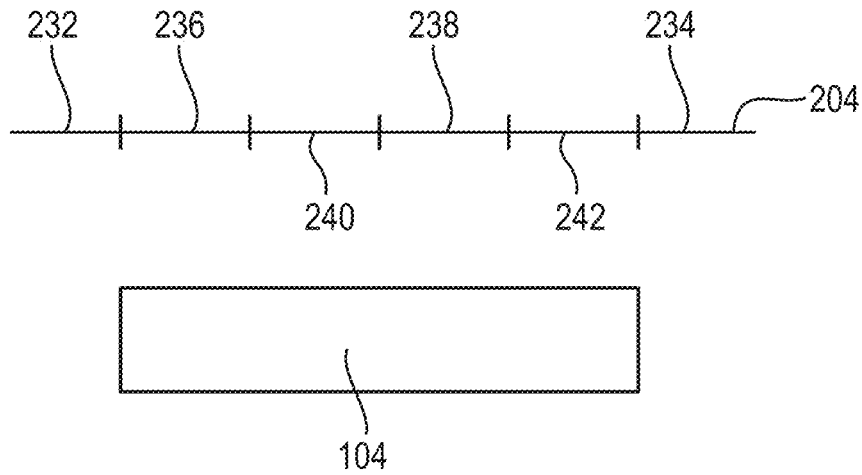

FIG. 2E

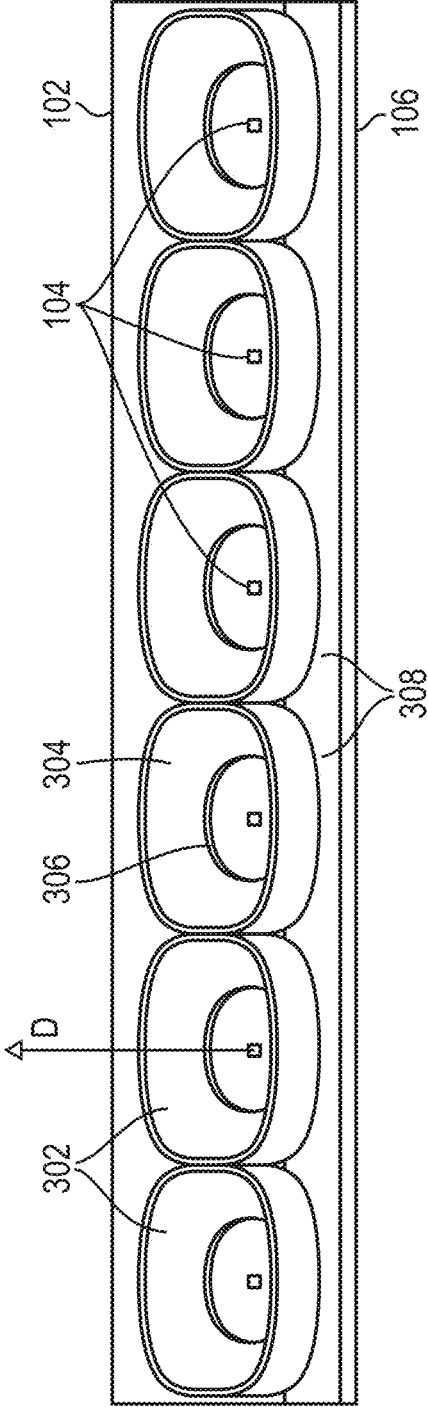

FIG. 3A

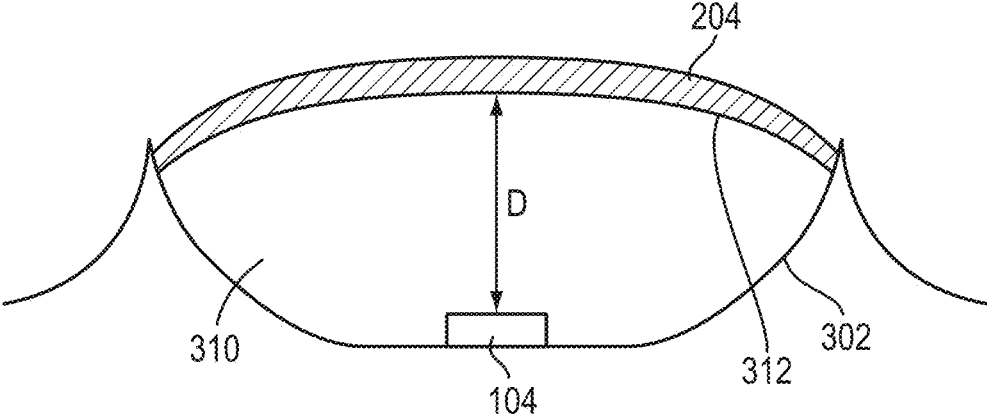

FIG. 3B

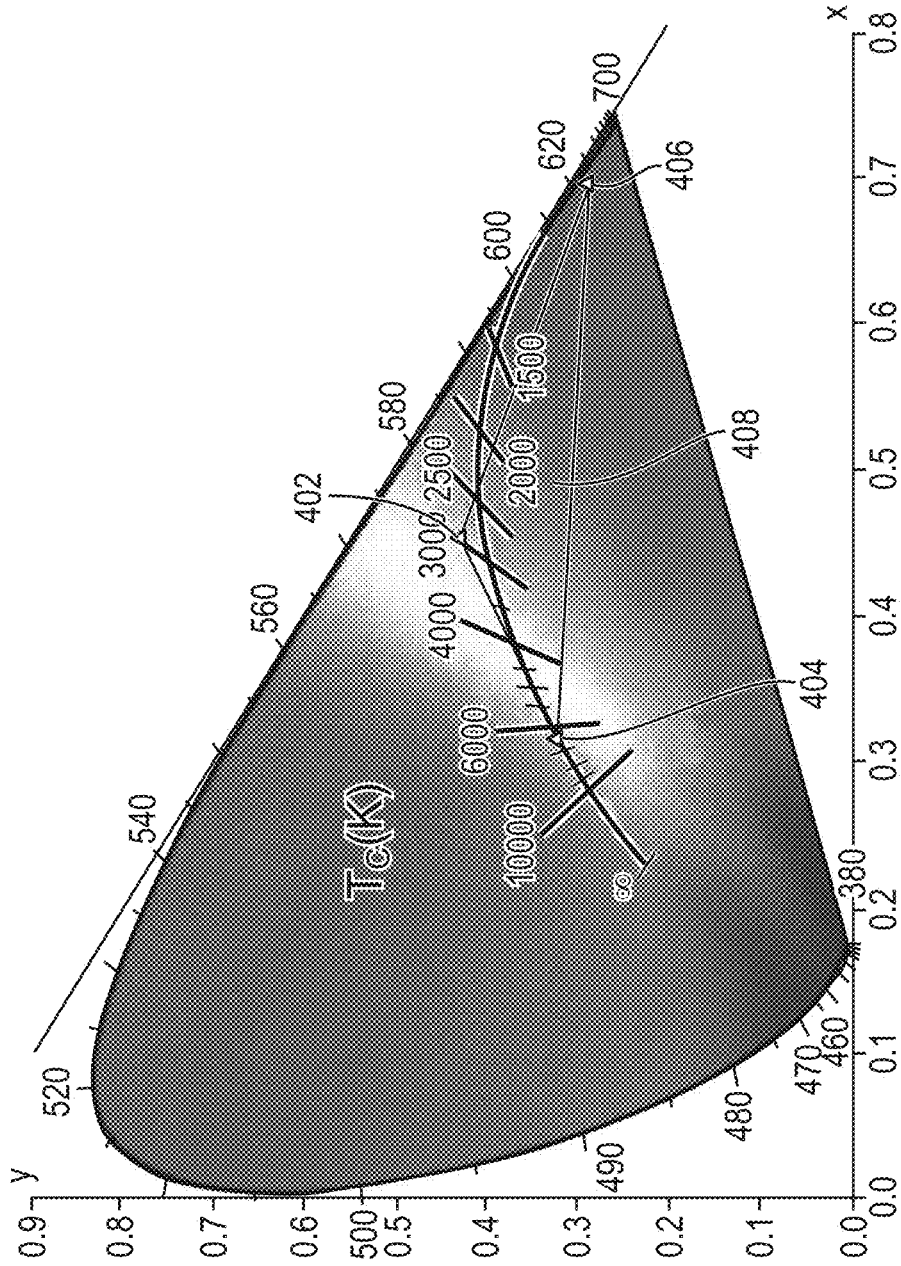

FIG. 4A

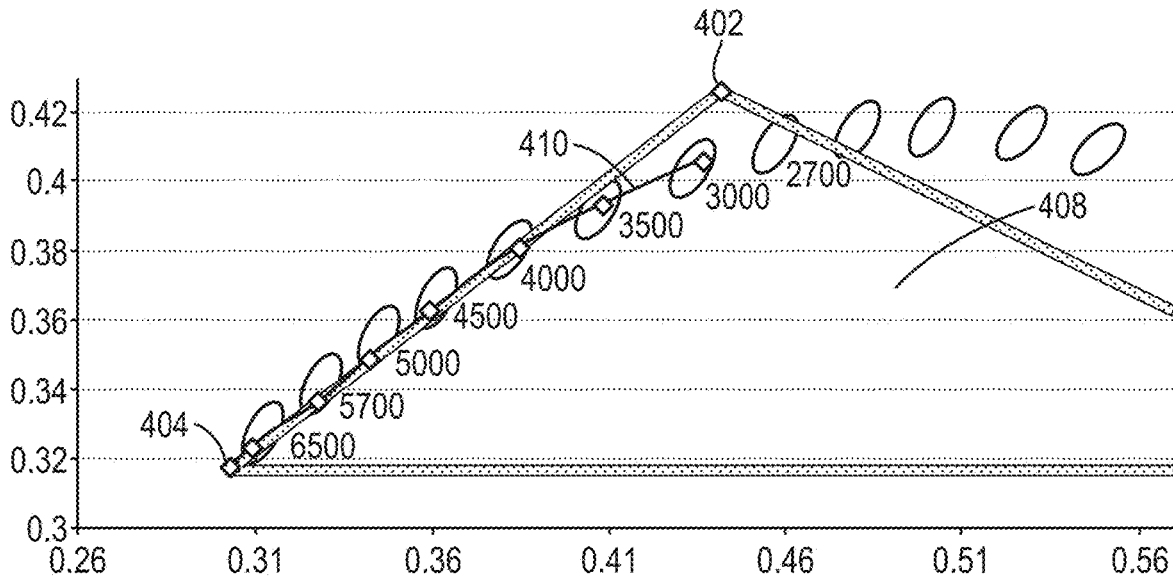

FIG. 4B

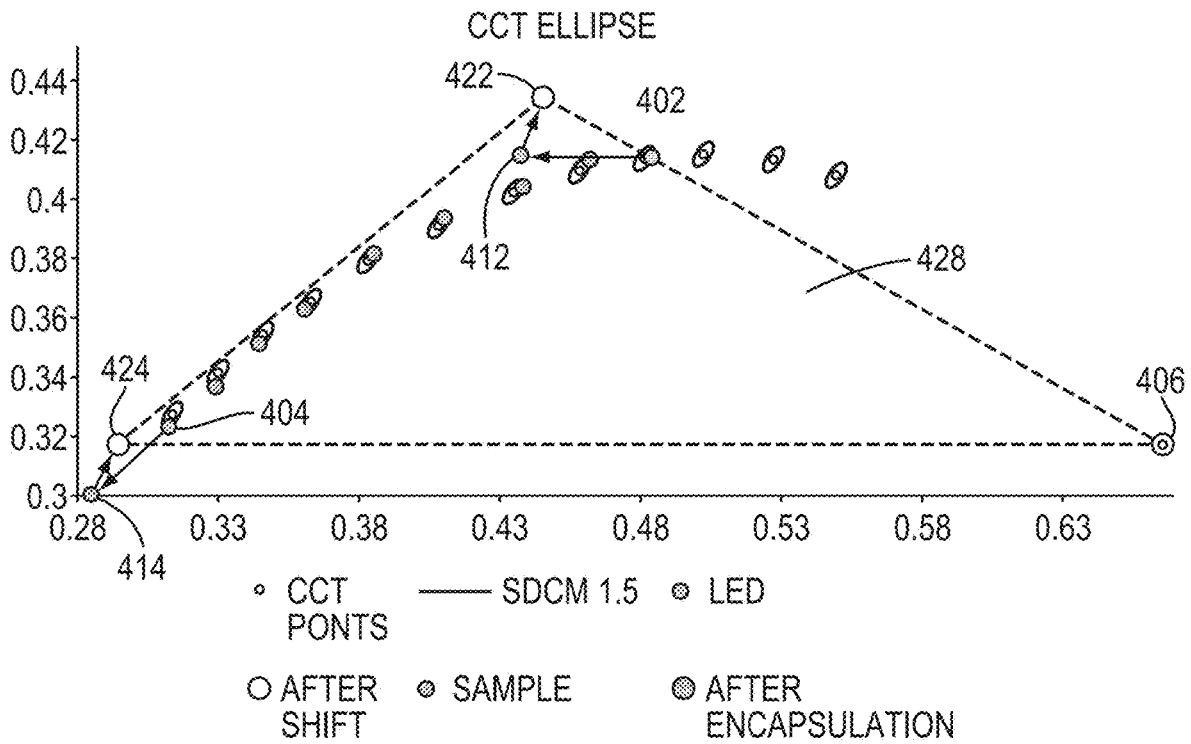

FIG. 4C

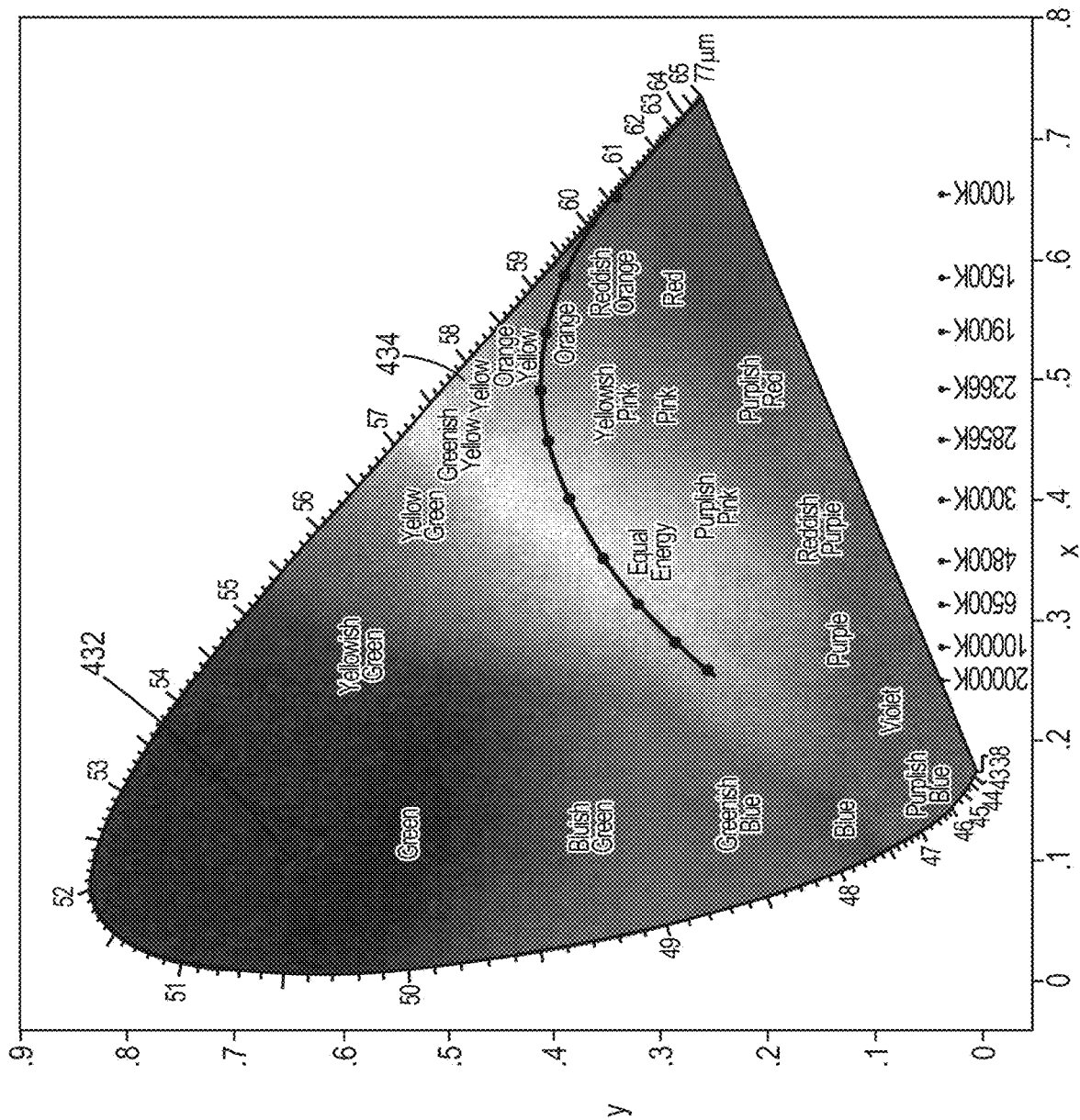

FIG. 4D

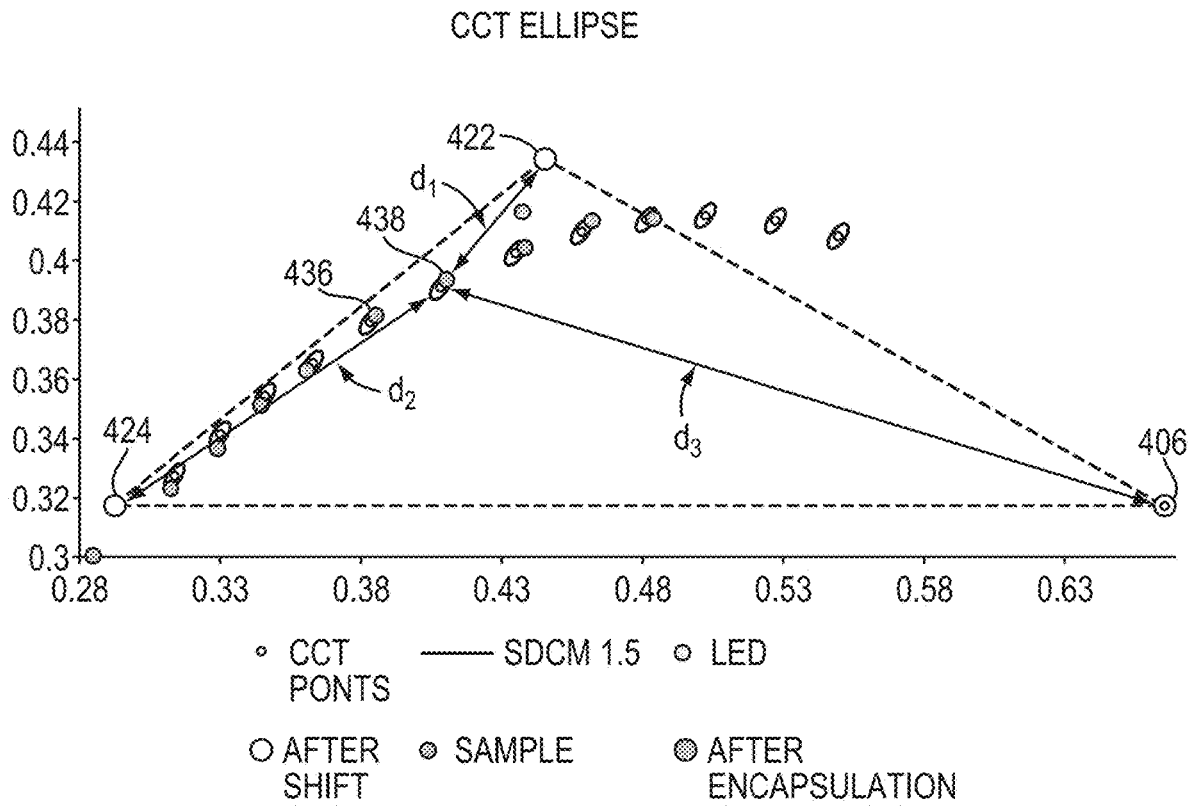

FIG. 4E

ADJUSTABLE WHITE LIGHT ILLUMINATION DEVICES

CROSS-REFERENCE TO RELATED APPLICATION

[0001] This application claims priority to and the benefit of U.S. Provisional Application Nos. 62/811,551 (filed on Feb. 28, 2019) and 62/677,405 (filed on May 29, 2018). The foregoing applications are incorporated herein by reference in their entireties.

TECHNICAL FIELD

[0002] The present invention relates generally to adjustable white light illumination devices, and in various embodiments more specifically to white light illumination devices comprising light-emitting diode (LED) devices.

BACKGROUND

[0003] An increasing number of light fixtures utilize LEDs as light sources due to their lower energy consumption, smaller size, improved robustness, and longer operational lifetime relative to conventional filament-based light sources. Conventional LEDs emit light at a particular wavelength, ranging from, for example, red to blue or ultraviolet (UV) light. However, for purposes of general illumination, the monochromatic emitted light by LEDs must be converted to broad-spectrum white light.

[0004] Conventional white LEDs are typically constructed as phosphor-converted LEDs where a blue LED is covered with a phosphor coating that converts a portion of the emitted blue light to yellow light so as to create white light. The photometric characteristics of the emitted light, such as a color correlated temperature (CCT) value or chromaticity coordinates in the CIE 1931 color space, are generally fixed. While such conventional LED lighting devices may be suitable for some uses, commercial establishments may have different demands—e.g., preferring the CCT of the light to change throughout the day along with the circadian rhythm of individuals (e.g., employees, customers, etc.) exposed to the light. For example, the CCT of the white light may desirably be lower in the late evenings to facilitate a healthy sleep cycle and higher in the afternoon to combat afternoon fatigue. Consequently, there is a need for LED devices that can emit white light with an adjustable CCT value.

SUMMARY

[0005] Accordingly, various embodiments of the present disclosure relate to an LED illumination device capable of emitting white light with tunable characteristics (e.g., a CCT value). In one embodiment, the LED illumination device employs an LED array having multiple LEDs that can be controlled individually or in a group to generate white light having a tunable CCT value within a range. For example, the LED illumination device may include one or more groups of LEDs, each group including at least one red LED emitting red light having an emission wavelength between approximately 600 nanometers (nm) and approximately 670 nm, one “warm” white LED emitting white light having a CCT value between approximately 1800K and approximately 2700K, and one “cool” white LED emitting white light having a CCT value between approximately 3000K and approximately 6500K. Alternatively, each group may include one red LED and two blue LEDs having an emission

wavelength between approximately 400 nm and approximately 530 nm; light emitted from the blue LEDs may be converted to the cool white light and warm white light using one or more photo-luminescent materials (e.g., phosphors, quantum dot materials, etc.). In some embodiments, each group of the LEDs includes three blue LEDs. Again, light emitted from two of the blue LEDs may be converted to the cool white light and warm white light. In addition, light emitted from the third blue LED may be converted to red light using, for example, deep-red quantum dots. Optionally, each of the LEDs may be disposed within a “cup-shaped” (e.g., parabolic) reflector for reducing “crosstalk” interactions between the light emitted from an LED and the photo-luminescent material(s) disposed above a neighboring LED. In addition, the reflector may be made of a high-reflectivity material so as to redirect upward light from the respective LED, thereby achieving at least partial collimation of the beam.

[0006] In various embodiments, the LEDs and/or photo-luminescent material(s) are encapsulated within a waveguide material made of, e.g., silicon. Light emitted from the LEDs, including unconverted light and light converted by the photo-luminescent material(s), can be mixed in a mixing region inside the waveguide and then directed to an output region for outputting white light for illumination. Because the waveguide material may cause more blue light to be extracted from the LEDs, the outputted white light may have a higher CCT value (corresponding to cooler white light). To at least partially counteract such an effect, in some embodiments, one or more photo-luminescent materials may be utilized to shift the CCT value of the light emitted from the cool white LED toward a green CCT value and/or to shift the CCT value of the light emitted from the warm white LED toward a yellow CCT value. The illumination device may also include control circuitry for varying a parameter (e.g., the amplitude and/or duty cycle of the applied current or voltage) associated with each LED (or in some embodiments, each group of the LEDs), thereby adjusting the CCT value of the mixed light to a target value.

[0007] Accordingly, in one aspect, the invention pertains to a lighting device producing white light having a target color correlated temperature (CCT) value. In various embodiments, the lighting device includes multiple LEDs having (i) one or more red LEDs emitting red light having a wavelength between approximately 600 nm and approximately 670 nm, (ii) one or more warm white LEDs emitting white light having a CCT value between approximately 1800K and approximately 2700K, and (iii) one or more cool white LEDs emitting white light having a CCT value between approximately 3000K and approximately 6500K; one or more photo-luminescent materials (e.g., a phosphor, a quantum dot material and/or a fluorescent dye) for shifting (i) the CCT value of the light emitted from the cool white LED(s) toward a green CCT value and/or (ii) the CCT value of the light emitted from the warm white LED(s) toward a yellow CCT value; and a waveguide material having (i) a mixing region for mixing the shifted and unshifted light so as to generate white light having the target CCT value and (ii) an output region for outputting the white light.

[0008] The lighting device may further include control circuitry for adjusting a parameter associated with the red LED(s), warm white LED(s) and/or cool white LED(s) so as to change the target CCT value of the generated white light. In one implementation, the parameter includes an amplitude

and/or a duty cycle of a current and/or a voltage associated with the red LED(s), warm white LED(s) and/or cool white LED(s). In addition, the control circuitry may be further configured to adjust the parameter of each of the red LED(s), warm white LED(s) and cool white LED(s) individually. In some embodiments, the LEDs include the first group of the red LEDs electrically coupled to one another, the second group of the warm white LEDs electrically coupled to one another, and the third group of the cool white LEDs electrically coupled to one another; the control circuitry is further configured to adjust each group of the red LEDs, warm white LEDs and cool white LEDs individually.

[0009] In various embodiments, the lighting device further includes multiple cup-shaped reflectors for at least partial collimation of light emitted from the LEDs. Each reflector may have a top aperture and a bottom aperture and the bottom aperture has one of the LEDs disposed therein. One or more of the reflectors may be a parabolic reflector, and the respective LED(s) disposed therein may be located at or near the focus of the parabolic reflector(s). In one embodiment, the reflectors include or consist essentially of silicone. In addition, the lighting device may further include an encapsulant material filled in a cavity space above one of the LEDs and surrounded by the respective reflector.

[0010] In various embodiments, one or more of the warm white LEDs and/or one or more of the cool white LEDs include (i) a blue LED emitting blue light having a wavelength between approximately 400 nm and approximately 530 nm, and (ii) a secondary photo-luminescent material (e.g., a (Gd, Y)₃(Al, Ga)₅O₁₂ phosphor), different from the photo-luminescent material(s), for converting at least a portion of the blue light to light having a wavelength longer than the blue light. In addition, the lighting device may further include a circuit board for mounting the LEDs thereon. In one embodiment, the lighting device further includes a heat-dissipation structure thermally coupled to the circuit board for dissipating heat generated by the LEDs. In addition, the lighting device may further include one or more reflectors located in the mixing region of the waveguide for promoting mixing of light. In one implementation, the waveguide material includes or consists essentially of silicone.

[0011] In another aspect, the invention relates to a lighting device producing white light having a target color correlated temperature (CCT) value. In various embodiments, the lighting device includes multiple LEDs including (i) one or more blue LEDs emitting blue light having a wavelength between approximately 400 nm and approximately 530 nm, (ii) one or more warm white LEDs emitting white light having a CCT value between approximately 1800K and approximately 2700K, and (iii) one or more cool white LEDs emitting white light having a CCT value between approximately 3000K and approximately 6500K; one or more photo-luminescent materials (e.g., a phosphor, a quantum dot material and/or a fluorescent dye) for shifting (i) the CCT value of the light emitted from the cool white LED(s) toward a green CCT value and/or (ii) the CCT value of the light emitted from the warm white LED(s) toward a yellow CCT value; a secondary photo-luminescent material (e.g., a deep-red quantum dot material), different from the photo-luminescent material(s), for converting the blue light to red light having a wavelength between approximately 600 nm and approximately 670 nm; and a waveguide material having (i) a mixing region for mixing the shifted and unshifted

light so as to generate white light having the target CCT value and (ii) an output region for outputting the white light.

[0012] The term “color” is used herein to denote the monochromatic or peak wavelength (or wavelengths) of light emitted by one or more LEDs. In addition, the term “uniform,” as used herein, refers to a light intensity distribution whose lower and upper intensity limits are within a factor of four, preferably within a factor of two of each other. As used herein, the terms “approximately,” “roughly,” and “substantially” mean $\pm 10\%$, and in some embodiments, $\pm 5\%$. Reference throughout this specification to “one example,” “an example,” “one embodiment,” or “an embodiment” means that a particular feature, structure, or characteristic described in connection with the example is included in at least one example of the present technology. Thus, the occurrences of the phrases “in one example,” “in an example,” “one embodiment,” or “an embodiment” in various places throughout this specification are not necessarily all referring to the same example. Furthermore, the particular features, structures, routines, steps, or characteristics may be combined in any suitable manner in one or more examples of the technology. The headings provided herein are for convenience only and are not intended to limit or interpret the scope or meaning of the claimed technology.

BRIEF DESCRIPTION OF THE DRAWINGS

[0013] In the drawings, like reference characters generally refer to the same parts throughout the different views. Also, the drawings are not necessarily to scale, with an emphasis instead generally being placed upon illustrating the principles of the invention. In the following description, various embodiments of the present invention are described with reference to the following drawings, in which:

[0014] FIGS. 1A and 1B depict a top view and a bottom view, respectively, of an example illumination system in accordance with various embodiments;

[0015] FIGS. 1C and 1D depict exemplary configurations of the LEDs in an illumination system in accordance with various embodiments;

[0016] FIG. 2A schematically depicts an exemplary three-dimensional configuration of an illumination system in accordance with various embodiments;

[0017] FIG. 2B depicts a spatial arrangement of LEDs and associated conversion layers for converting the wavelength of at least a portion of the LED light in accordance with various embodiments;

[0018] FIGS. 2C and 2D depict LED arrays including various combinations of different types of LEDs in accordance with various embodiments;

[0019] FIG. 2E depicts a conversion layer including multiple regions in accordance with various embodiments;

[0020] FIGS. 3A and 3B depict an implementation of reflectors surrounding the LEDs in an illumination system in accordance with various embodiments;

[0021] FIGS. 4A and 4B depict exemplary color coordinates of the light emitted from a warm white LED, a cool white LED, and a red LED in the CIE 1931 color space in accordance with various embodiments;

[0022] FIG. 4C depicts shifts of color coordinates in the color space resulting from a waveguide/encapsulant material and one or more photo-luminescent materials in accordance with various embodiments;

[0023] FIG. 4D depicts a green region and a yellow region in the CIE 1931 color space in accordance with various embodiments; and

[0024] FIG. 4E depicts adjustments of the CCT value along the Black Body Curve (BBC) in accordance with various embodiments.

DETAILED DESCRIPTION

[0025] FIG. 1A conceptually illustrates an exemplary illumination system **100** including one or more strip lighting devices **102** in accordance herewith; each strip **102** has an array of multiple LEDs **104** mounted to a circuit board **106** (e.g., printed circuit board, PCB). Each of the LED groups **104** may include one or more LED dies for emitting light with the same or different characteristics (e.g., colors, powers and/or CCT values). The LEDs **104** may be electrically coupled, via the circuit board **106**, to connectors **108** mounted on each end of the circuit board **106**. The connectors **108** may then electrically couple the LEDs **104** to an external device **110** (e.g., another lighting device, a dimming device, a power supply, an “Internet of things” (IoT) device, or a combination thereof such that the LEDs **104** may receive power from the external device **110** via the connectors **108** and emit light.

[0026] In some embodiments, the LEDs **104** are electrically coupled to control circuitry **112** in the strip lighting device(s) **102**. The control circuitry **112** may be configured to control operation of the LEDs **104** (e.g., by regulating the amplitude and/or duty cycle of the current and/or voltage applied to the LEDs **104**), thereby regulating a characteristic (e.g., intensity or brightness) of the light emitted from the LEDs **104**. For example, the control circuitry **112** may adjust the brightness of individual LEDs using pulse width modulation (PWM). For example, the control circuitry **112** may rapidly turn individual LEDs on and off at a high frequency that is imperceptible to humans. In this example, the brightness of the individual LEDs **104** may be changed by adjusting the ratio of on-time to off-time within a particular cycle (sometimes referred to as a “duty cycle”). The higher the ratio of on-time to off-time, the brighter the LED. Conversely, lowering the ratio of on-time to off-time dims the LED. Thus, the duty cycle may positively correlate to the average flux of the LED being controlled. The control circuitry **112** may vary the ratio of on-time to off-time based on control signals received from the external device **110** via the connectors **108**. In one embodiment, the control circuitry **112** is implemented in circuitry that is external to the illumination system **100**. For example, circuitry in the external device **100** may be configured to regulate the current and/or voltage applied to the LEDs **104**, thereby directly controlling operations thereof. In this case, the control circuitry **112** may be omitted from the illumination system **100** altogether.

[0027] Generally, the LEDs **104**, control circuitry **112**, and/or the connectors **108** are all mounted to the circuit board **106**. For example, the circuit board **106** may include one or more conductors to electrically couple the components mounted thereto. In addition, the circuit board **106** may be flexible to enable the illumination system **100** to conform to uneven surfaces. Referring to FIG. 1B, in some embodiments, the bottom surface of the circuit board **106** is connected to a heat dissipation structure **120** (e.g., a conventional heat sink) for dissipating heat generated by the LEDs **104**.

[0028] The strip lighting device(s) **102** in the illumination system **100** may have particular dimensions to enable a wide range of applications. For example, the lighting devices **102** may have a depth of no more than approximately 1 inch, a length of no more than approximately 25 inches, and a width of no more than approximately 4 inches. It should be appreciated that the strip lighting devices **102** may be constructed with other dimensions, and may be two-dimensional arrays of LED groups rather than one-dimensional strips.

[0029] In various embodiments, the LEDs **104** are separated by a distance (e.g., 25 millimeters (mm) or 3 mm). In addition, each of the LEDs **104** may be configured to emit light with the same or different characteristic (e.g., wavelength, CCT value, etc.). In one embodiment, the strip lighting devices **102** include one or more groups of LEDs, each group including at least one red LED **104-1** having a wavelength between approximately 600 nm and approximately 670 nm, one “warm” white LED **104-2** emitting white light having a CCT value between approximately 1800K and approximately 2700K, and one “cool” white LED **104-3** emitting white light having a CCT value between approximately 3000K and approximately 6500K. The group of LEDs **104-1**, **104-2**, **104-3** may be aligned consecutively on the same strip lighting device **102** (as depicted in FIG. 1A) or in any suitable configurations for generating white light with an adjustable characteristic (e.g., a CCT value) as further described below. For example, referring to FIG. 1C, the group of LEDs **104-1**, **104-2**, **104-3** may be disposed on the same column on consecutive strips **102** abutting one another. Alternatively, referring to FIG. 1D, the two white LEDs **104-2**, **104-3** may be disposed next to each other on the same strip **102** while the red LED **104-1** may be disposed next to one of the white LEDs **104-2**, **104-3** but on a different strip.

[0030] The LEDs **104** may be operated individually or in a grouped manner. For example, each LED may be independently coupled to the control circuitry **112** such that the control circuitry **112** can separately control individual LEDs. Alternatively, some of the LEDs **104** may be wired together to allow the control circuitry **112** to control them as a single unit; different groups may or may not share one or more LEDs **104**. For example, as described above, the illumination device **100** may include multiple groups of LEDs, each group including at least one red LED **104-1**, one warm white LED **104-2**, and one cool white LED **104-3**. In one embodiment, the LEDs **104-1**, **104-2**, **104-3** in each group are electrically coupled such that the control circuitry **112** can control the LEDs **104-1**, **104-2**, **104-3** equivalently. In another embodiment, the red LEDs **104-1** in at least some groups are electrically coupled together; this allows the control circuitry **112** to control equivalently all red LEDs **104-1** that are electrically coupled. Similarly, the warm white LEDs **104-2** in at least some groups may be electrically coupled together, and the cool white LEDs **104-3** in at least some groups are electrically coupled together. This way, the groups of warm white LEDs **104-2** and cool white LEDs **104-3** may be separately controlled by the control circuitry **112** in a group manner.

[0031] Referring to FIG. 2A, in some embodiments, light emitted from the LEDs **104** travels through the space of a surrounding cavity **202** and is incident upon one or more conversion layers **204** that include one or more photoluminescent materials (e.g., phosphors, quantum dot mate-

rials, etc.) for converting the LED light. The conversion layer(s) **204** absorbs at least some of the light emitted from the LEDs **104** and re-emits at least some of the absorbed light in a spectrum containing one or more wavelengths that are different from the absorbed light. In various embodiments, the photo-luminescent material(s) contained in the conversion layer(s) **204** is chosen based at least in part on the waveguide material. This is because the waveguide material may cause a larger portion of the blue light from the white LEDs **104-2**, **104-3** to be extracted; this may result in a shift of the CCT value of light emitted from the white LEDs **104-2**, **104-3** toward a higher CCT value (i.e., cooler white light). In one embodiment, the photo-luminescent material (s) on the conversion layer(s) **204** is chosen such that the wavelength shift thereby can at least partially counteract the shift resulting from the waveguide material as further described below. For example, the same or different photo-luminescent materials (e.g., phosphor QMK58/F-U2) may be applied to shift the CCT value of the light emitted from the cool white LED **104-3** toward a green CCT value and/or to shift the CCT value of the light emitted from the warm white LED **104-2** toward a yellow CCT value.

[0032] In one embodiment, the conversion layer(s) **204** is constructed from a foil that includes a composition of photo-luminescent materials. For example, the foil may be premade using a conventional substrate material (e.g., one or more layers of polymer such as PET) and a binder material (such as silicone); the composition of photo-luminescent materials is then disposed on the substrate surface. Referring to FIG. 2B, when multiple conversion layers **204** are used, the foils including different compositions of photo-luminescent materials may be placed on top of each other with or without a gap therebetween. In one embodiment, one or more layers made of polymer can be implemented to separate the conversion layers. In addition, a second layer made of the substrate material may be applied to the conversion layer(s) **204** so as to cover the photo-luminescent materials thereon. In some embodiments, the foil in the conversion layer(s) **204** includes one or more quantum dot materials. In addition, the foil may include a quantum dot enhancement film (QDEF) made by 3M Inc, or Nanoco Technology Ltd. to provide a geometry for deploying the quantum dot materials.

[0033] As described above, the conversion layer(s) **204** may absorb at least some of the light emitted from the LEDs **104** and re-emit (or converts) at least some of the absorbed light in a spectrum containing one or more wavelengths that are different from (typically longer than) the light emitted by the LEDs **104**. The wavelength of the converted light may depend on the composition ratio of the photo-luminescent materials, the characteristics associated with each photo-luminescent material, and the wavelength of the light emitted from LEDs **104**. The LEDs may include a monochrome LED with a narrow band spectrum (e.g., a red LED having a wavelength between approximately 600 nm and approximately 670 nm, a blue LED having a wavelength between approximately 400 nm and approximately 530 nm, and/or an UV LED having a wavelength between approximately 100 nm and approximately 400 nm) and/or a phosphor-converted LED with a wider band spectrum (e.g., the warm white LED **104-2** and/or cool white LED **104-3**). The converted and unconverted light may then be mixed in the waveguide material to generate light having a target characteristic (e.g.,

color and/or CCT value); the target characteristic may be tunable within a range as further described below.

[0034] In some embodiments, each group of the LEDs depicted in FIGS. 1A, 1C and 1D may include one red LED **104-1** and two blue LEDs **104-2**, **104-3** (instead of one red LED and two white LEDs described above). In addition, referring to FIG. 2C, the conversion layer(s) **204** may be disposed above the blue LEDs **104-2**, **104-3** only, and not the red LED **104-1**. The photo-luminescent material(s) may convert at least some of the blue light emitted from the blue LEDs **104-2**, **104-3** to light having a longer wavelength. For example, a $(\text{Gd}, \text{Y})_3(\text{Al}, \text{Ga})_5\text{O}_{12}$ phosphor may convert blue light to yellow light. The converted light (e.g., yellow light) and unconverted blue light may then be mixed to generate white light. Thus, by choosing the photo-luminescent material(s) and/or adjusting the composition thereof, the light emitted from the blue LEDs **104-2**, **104-3** may be converted to thereby generate warm white light and cool white light, respectively. In one embodiment, one or more additional conversion layers **204** are utilized to shift the CCT value of the light emitted from the cool white LED **104-3** toward a green CCT value and/or to shift the CCT value of the light emitted from the warm white LED **104-2** toward a yellow CCT value as further described below.

[0035] In some embodiments, the LED array includes blue LEDs only. For example, referring to FIG. 2D, light emitted from two of the blue LEDs **104-2**, **104-3** may be converted. to generate warm white light and cool white light as described above. In addition, the conversion layer(s) **204** having suitable photo-luminescent material(s) (e.g., deep-red quantum dots by Nanoco Technology Ltd.) may be disposed above the third blue LEDs **104-4** so as to convert the light emitted therefrom to red light having a peak wavelength at approximately 650 nm. Again, the light emitted from the LEDs, including both converted and unconverted light, may be mixed to generate light having a characteristic (e.g., color, CIE chromaticity coordinates and/or CCT value) that is tunable within a range.

[0036] Referring to FIG. 2E, in various embodiments, the conversion layer(s) **204** is divided into multiple regions **232-242**; each region is either uncoated or coated with the same or different photo-luminescent materials. For example, regions **232**, **234** may be uncoated to allow unconverted blue light from the LED to travel through; regions **236**, **238** may be coated with the first type of photo-luminescent material such that the converted light, after being mixed with the unconverted light, generates cool white light; and regions **240**, **242** may be coated with the second type of photo-luminescent material such that the converted light, after being mixed with the unconverted light, generates cool white light. Thus, by utilizing different types of photo-luminescent materials having different characteristics at different locations over the LEDs **104**, a target spectral power distribution (SPD) of the light may be achieved.

[0037] Referring again to FIG. 2B, the light emitted from an LED **104** may interact with the photo-luminescent material(s) disposed above a neighboring LED, cause a “cross-talk” interaction, and thereby result in additional colors. To reduce the crosstalk interaction, referring to FIG. 3A, each LED **104** in the strip lighting device **102** may be surrounded by a “cup-shaped” reflector **302**. As shown, each cup-shaped reflector **302** typically has a top aperture **304** and a bottom aperture **306**; the LED **104** is disposed inside of the bottom aperture **306**. The shapes of the apertures **304**, **306** may be,

for example, circular, elliptical, rectangular, square, etc., and may be the same or different from each other. In one embodiment, the reflectors 302 abut each other such that the bottom portions 308 thereof form a continuous surface. The reflectors 302 may be made of a high reflectivity material, such as MS-2002 silicone from DOWSIL.

[0038] In some embodiments, the geometry of the cup-shaped reflectors 302 is configured to provide a uniform distribution of the light intensity at a specific distance, D, above the LED 104 where the conversion layer(s) 204 is typically disposed. In one embodiment, the reflector 302 is a parabolic reflector (i.e., a reflecting optic whose reflective surface forms a truncated paraboloid), and the LED 104 is placed at or near the focus of the paraboloid. Thus, a light beam emitted from the LED 104 onto the reflector 302 may be redirected upward for at least partial collimation of the beam.

[0039] Referring to FIG. 3B, in various embodiments, an encapsulant material is potted over the LED 104 within a cavity space 310 created by the reflector 302 to at least partially encapsulate the LED 104. In one embodiment, the height of the encapsulant material above the LED 104 approximately corresponds to the specific distance D described above, thus the light intensity on the top surface 312 of the cavity space 310 may be uniformly distributed without having any visible high intensity spots thereon. The encapsulant material may include, consist of, or consist essentially of a clear material such as silicon. Alternatively, the encapsulant material may form a cover having a convex or domed shape on top of the reflector aperture 304; the cavity space 310 can be filled with gas or instead can be under vacuum. In addition, one or more conversion layers 204 including one or more types of photo-luminescent materials (e.g., phosphors, quantum dot materials, etc.) may be coated inside and/or outside the top surface 312 of the encapsulant material to convert the light emitted from the LEDs 104 as described above. In some embodiments, the cavity space 310 is at least partly filled by the encapsulant material that includes a composition of the photo-luminescent material(s) and waveguide material so as to allow the photo-luminescent material(s) to be embedded in the waveguide material.

[0040] Referring again to FIG. 2A, in one embodiment, the cavity 202 formed between the circuit board 106 and the conversion layer(s) 204 is filled with a waveguide material (e.g., silicone) such that the waveguide material is in direct contact with the top surface of the circuit board 106 and the conversion layer(s) 204. In addition, one or more reflectors 210-214 may be disposed on the top, bottom and/or side surfaces of the waveguide, respectively, such that the light emitted from the LEDs 104, including both unconverted and converted light by the conversion layer(s) 204, can be mixed inside a mixing region 216 of the waveguide; the mixed light then propagates to an output region 218 of the waveguide for outputting the light. In addition, a reflector 219 may be disposed on the top surface of the circuit board 106. In one embodiment, at least one of the reflectors 210-214, 219 is made of a high-reflectivity silicone (e.g., CI2001 from DOWSIL). Alternatively, a high-reflectivity foil may be used as one or more of the reflectors 210-214, 219. It should be noted that although FIG. 2A depicts the LEDs 104 and conversion layer(s) 206 disposed on one side 220 of the waveguide only, they may be disposed on another side 222 with the similar spatial arrangement. In addition,

the location of the output region 218 may be anywhere on the waveguide and is not limited to the top surface of the waveguide as depicted in FIG. 2A.

[0041] In one implementation, the entire circuit board 106 is encapsulated inside the waveguide; the illumination system 100 may include a heat-conducting path connecting the bottom surface of the circuit board 106 to an outer surface of the waveguide for dissipating heat generating by the LEDs 104. In one embodiment, the heat-conducting path is formed by using a heat conductive material as a part of the waveguide material and disposing the circuit board 106 to be in directly contact with the waveguide.

[0042] As discussed above, the LEDs 104 mounted on the circuit board 106 may be controlled individually or in a group manner to generate light having a tunable CCT value within a range. The particular range in which the CCT value can be varied may depend on the configurations of the LEDs, such as the particular combination of the LEDs. FIG. 4A depicts exemplary color coordinates 402, 404, 406 of the warm white LED 104-2, cool white LED 104-3, and red LED 104-1, respectively, in the CIE 1931 color space in accordance with various embodiments. As shown, the color coordinates 402, 404, 406 form vertices of a triangular region 408; thus, the color coordinates of light produced by such a combination of LEDs 104-1, 104-2, 104-3 can be tuned within the triangular region 408. FIG. 4B depicts an enlarged view of a region of the triangular region 408. As shown, the CCT value of the light generated by the red LED, warm white LED and cool white LED can be tuned along the Black Body Curve 410 with a deviation of less than 3.0 SDCM (Mac Adam's ellipse). Further details about combining various LEDs to generate white light having a tunable CCT value are provided, for example, in International Application No. WO 2018/157166 (filed on Feb. 27, 2018), the entire content of which is incorporated herein by reference.

[0043] As described above, the LEDs 104 may be encapsulated in a waveguide material (FIG. 2A) and/or an encapsulant material (FIG. 3B). As a result, a large portion of the blue light from the LEDs is extracted from the LEDs, which in turn causes shifts of the CCT values associated with the warm white light and cool white light. For example, referring to FIG. 4C, the color coordinates of the light emitted from the warm white LED 104-2 may be shifted from a location 402 (approximately 2700K) to a location 412 (3000K); similarly, the color coordinates of the light emitted from the cool white LED 104-3 may be shifted from a location 404 (approximately 6500K) to a location 414 (8000K). The degree of shifting may depend on the material characteristics of the waveguide and/or an encapsulant. It should be noted that because the waveguide material and/or encapsulant material has no (or at least limited) effect on the color coordinates 406 of the red light emitted from the red LED 104-1, there may be no need for applying the photo-luminescent material(s) thereto.

[0044] In various embodiments, the color coordinate shifts resulting from the waveguide and/or encapsulant are at least partially counteracted by using, for example, one or more photo-luminescent materials (e.g., phosphor QMK58/F-U2) disposed on the conversion layer(s) 204. In one embodiment, the photo-luminescent material(s) shifts the CCT value of the light emitted from the cool white LED 104-3 toward a green CCT value (e.g., from the location 414 to a location 424) and/or the (Cx, Cy) value of the light emitted from the warm white LED 104-2 toward a yellow (Cx, Cy)

value (e.g., from the location **412** to a location **422**). As a result, the color coordinates of the light generated by mixing the cool white light, warm white light and red light that have color coordinates at locations **424**, **422**, **406**, respectively, can be tuned within a new triangular region **428** formed by the new vertices **424**, **422**, **406**. In various embodiments, the CCT value of the mixed light can be tuned along the Black Body Curve **410** with a deviation of less than 1.5 SDCM.

[0045] It should be noted that the green CCT value and yellow CCT value toward which the CCT values of the cool white light and warm white light are shifted do not necessarily correspond to specific CCT values. Rather, referring to FIG. 4D, the green CCT value and yellow CCT value can be any color coordinates located within the green region **432** and yellow region **434** in the color space. In addition, for purposes hereof, the green region **432** includes all color coordinates in the color space corresponding to wavelengths between approximately 480 nm and approximately 550 nm, and the yellow region **434** includes all color coordinates in the color space corresponding to wavelengths between approximately 550 nm and approximately 590 nm.

[0046] Referring to FIG. 4E, in various embodiments, the CCT value of the mixed light is adjusted along the BBC with a deviation of less than 1.5 SDCM so as to match or complement the human circadian rhythm. The adjustment of the CCT value can be achieved by changing the intensity of the light emitted from one or more of the LEDs **104-1**, **104-2**, **104-3**. For example, when a target CCT value of the mixed light changes from a location **436** to a location **438** in the color space, the intensity of the cool white LED **104-3** may be reduced, while the intensity of the warm white LED **104-2** and/or red LED **104-1** may be increased. In various embodiments, the intensity contribution of the light from each LED negatively correlates to the distance between the color coordinates of the LED light and the target color coordinates in the color space. For example, assuming the target color coordinates being at the location **438**, because the distance, d_1 , between the color coordinates **422** of the warm white light and the target color coordinates **438** is smaller than the distance, d_2 , between the color coordinates **424** of the cool white light and the target color coordinates **438**, the intensity contribution from the warm white light may be larger than that from the cool white light. Similarly, because the distance d_2 is smaller than the distance, d_3 , between the color coordinates **406** of the red light and the target color coordinates **438**, the intensity contribution from the cool white light may be larger than that from the red light.

[0047] In some embodiments, the control circuitry **112** adjusts the intensity of the light emitted from one or more of the LEDs **104-1**, **104-2**, **104-3** by varying the amplitude and/or duty cycle of the current and/or voltage associated therewith. In addition, the control circuitry **112** may include a look-up table that maps particular target CCT values to a set of intensity ratios for the LEDs within the LED array. Thus, when the control circuitry **112** receives information indicative of a desired CCT value, it may access the look-up table to retrieve the corresponding intensity ratios, and, based thereon, adjust the intensities of the LEDs.

[0048] The control circuitry **112** may include or be connected to one or more modules implemented in hardware, software, or a combination of both. For embodiments in which the functions are provided as one or more software programs, the programs may be written in any of a number

of high level languages such as PYTHON, FORTRAN, PASCAL, JAVA, C, C++, C #, BASIC, various scripting languages, and/or HTML. Additionally, the software can be implemented in an assembly language directed to the micro-processor resident on a target computer; for example, the software may be implemented in Intel 80x86 assembly language if it is configured to run on an IBM PC or PC clone. The software may be embodied on an article of manufacture including, but not limited to, a floppy disk, a jump drive, a hard disk, an optical disk, a magnetic tape, a PROM, an EPROM, EEPROM, field-programmable gate array, or CD-ROM. Embodiments using hardware circuitry may be implemented using, for example, one or more FPGA, CPLD or ASIC processors.

[0049] The terms and expressions employed herein are used as terms and expressions of description and not of limitation, and there is no intention, in the use of such terms and expressions, of excluding any equivalents of the features shown and described or portions thereof. In addition, having described certain embodiments of the invention, it will be apparent to those of ordinary skill in the art that other embodiments incorporating the concepts disclosed herein may be used without departing from the spirit and scope of the invention. Accordingly, the described embodiments are to be considered in all respects as only illustrative and not restrictive.

What is claimed is:

1.-17. (canceled)

18. A lighting device producing white light having a target color correlated temperature (CCT) value, the lighting device comprising:

a plurality of LEDs comprising (i) at least one first LED producing white light having a CCT value between approximately 1800K and approximately 2700K, and (ii) at least one second LED producing (a) blue light having a wavelength between approximately 400 nm and approximately 530 nm, (b) UV light having a wavelength between approximately 100 nm and approximately 400 nm, or (c) white light having a CCT value between approximately 3000K and approximately 6500K;

at least one photo-luminescent material for shifting at least one of (i) the CCT value of the light emitted from at least one said second LED toward a green CCT value or (ii) the CCT value of the light emitted from at least one said first LED toward a yellow CCT value; and

a waveguide material having (i) a mixing region for mixing the shifted and unshifted light so as to generate white light having the target CCT value and (ii) an output region for outputting the white light.

19. The lighting device of claim **18**, wherein at least one of the plurality of LEDs is embedded within the waveguide material.

20. The lighting device of claim **18**, wherein at least one said first LED is embedded within the waveguide material.

21. The lighting device of claim **18**, wherein the waveguide material comprises silicone.

22. The lighting device of claim **18**, further comprising control circuitry for adjusting a parameter associated with (i) at least one said first LED, and/or (ii) at least one said second LED so as to change the target CCT value of the generated white light.

23. The lighting device of claim **22**, wherein the parameter comprises at least one of an amplitude or a duty cycle of a current or a voltage.

24. The lighting device of claim **22**, wherein the control circuitry is configured to adjust the parameter of each of the (i) at least one said first LED, and (ii) at least one said second LED individually.

25. The lighting device of claim **22**, wherein:
the at least one first LED comprises a plurality of first LEDs electrically coupled together;
the at least one second LED comprises a plurality of second LEDs electrically coupled together; and
the control circuitry is configured to individually adjust (i) the plurality of first LEDs, and (ii) the plurality of second LEDs.

26. The lighting device of claim **22**, wherein:
the plurality of LEDs comprises at least one red LED producing red light having a wavelength between approximately 600 nm and approximately 670 nm; and
the control circuitry is configured to adjust a parameter associated with at least one said red LED.

27. The lighting device of claim **18**, wherein the plurality of LEDs comprises at least one red LED producing red light having a wavelength between approximately 600 nm and approximately 670 nm.

28. The lighting device of claim **27**, wherein the at least one red LED comprises a plurality of red LEDs electrically coupled together.

29. The lighting device of claim **18**, wherein the at least one photo-luminescent material comprises at least one of a phosphor, a quantum dot material, or a fluorescent dye.

30. The lighting device of claim **18**, further comprising a plurality of cup-shaped reflectors for at least partial collimation of light emitted from the LEDs, wherein each reflector has a top aperture and a bottom aperture and the bottom aperture has one of the LEDs disposed therein.

31. The lighting device of claim **30**, wherein at least one of the reflectors is a parabolic reflector, the respective LED disposed therein being located at or near a focus of the parabolic reflector.

32. The lighting device of claim **30**, further comprising an encapsulant material filled in a cavity space above one of the plurality of LEDs and surrounded by the respective reflector.

33. The lighting device of claim **30**, wherein the reflectors comprise silicone.

34. The lighting device of claim **18**, wherein at least one said first LED comprises (i) a blue LED emitting blue light having a wavelength between approximately 400 nm and approximately 530 nm or a UV LED having a wavelength between approximately 100 nm and approximately 400 nm, and (ii) a secondary photo-luminescent material, discrete from the at least one photo-luminescent material, for converting at least a portion of the blue light to light having a wavelength longer than the blue light.

35. The lighting device of claim **18**, further comprising at least one reflector located in the mixing region of the waveguide for promoting mixing of light.

36. The lighting device of claim **18**, wherein:
the waveguide material defines a planar waveguide having opposed top and bottom surfaces;
the plurality of LEDs are configured to emit light into the waveguide proximate the bottom surface thereof; and
the output region is at least a portion of the top surface of the waveguide.

37. The lighting device of claim **36**, wherein the output region is only a first portion of the top surface of the waveguide.

38. The lighting device of claim **37**, further comprising a reflector disposed on a second portion of the top surface of the waveguide different from the first portion.

* * * * *