



(11) **EP 1 869 250 B1**

(12) **EUROPEAN PATENT SPECIFICATION**

(45) Date of publication and mention of the grant of the patent:
14.09.2011 Bulletin 2011/37

(51) Int Cl.:
D21C 7/06^(2006.01) D21C 3/24^(2006.01)
D21C 7/08^(2006.01)

(21) Application number: **06717121.5**

(86) International application number:
PCT/SE2006/050037

(22) Date of filing: **21.03.2006**

(87) International publication number:
WO 2006/101449 (28.09.2006 Gazette 2006/39)

(54) **ARRANGEMENT FOR FEEDING A SLURRY OF CHIPS AND LIQUID**

ANORDNUNG ZUR ZUFÜHRUNG EINER AUFSCHLÄMMUNG AUS SCHNITZELN UND FLÜSSIGKEIT

DISPOSITIF PERMETTANT D'APPORTER UNE SUSPENSION EPAISSE DE COPEAUX ET DE LIQUIDE

(84) Designated Contracting States:
AT BE BG CH CY CZ DE DK EE ES FI FR GB GR HU IE IS IT LI LT LU LV MC NL PL PT RO SE SI SK TR

(30) Priority: **23.03.2005 SE 0500672**

(43) Date of publication of application:
26.12.2007 Bulletin 2007/52

(73) Proprietor: **Metso Paper Sweden AB**
851 94 Sundsvall (SE)

(72) Inventors:
• **SAETHERÅSEN, Jonas**
S-663 42 Hammarö (SE)

• **SNEKKENES, Vidar**
S-652 19 Karlstad (SE)
• **WILKE, Bo**
653 46 Karlstad (SE)
• **GUSTAVSSON, Lennart**
653 50 Karlstad (SE)

(56) References cited:
WO-A1-03/078727 SE-C- 180 289
US-A- 4 123 318 US-A- 5 236 285
US-A- 5 736 006 US-A- 5 968 314
US-A1- 2002 059 991 US-B1- 6 436 233

EP 1 869 250 B1

Note: Within nine months of the publication of the mention of the grant of the European patent in the European Patent Bulletin, any person may give notice to the European Patent Office of opposition to that patent, in accordance with the Implementing Regulations. Notice of opposition shall not be deemed to have been filed until the opposition fee has been paid. (Art. 99(1) European Patent Convention).

Description

Technical Area

[0001] The present invention concerns a method and an arrangement for the feed of a chips suspension from one vessel to a subsequent digester in a continuous cooking process for the production of chemical cellulose pulp, as specified by patent claim 1.

The Prior Art

[0002] The use of scraper devices at the bottom of digesters and impregnation vessels in the continuous cooking of chemical cellulose pulp has been long known. The aim of these scraper devices is to ensure a continuous output of the cellulose pulp or chips from the vessel. The scraper device consists of a number of scraper arms that are arranged on the shaft that is arranged to be vertical during production. The motion of the arms in the suspension of pulp or chips counteracts the formation of blockages, the formation of channels, and other undesired effects.

[0003] The above-mentioned shaft for the operation of the said scraper arms has been used since early times for the addition of fluid at the lower part of the digester or impregnation vessel. The addition of fluid occurs in this case by making the shaft hollow and leading fluid in through this way. The primary purpose of adding fluid has been to wash the pulp. This addition of fluid through the shaft has more recently been used for the dilution of the pulp with the aim of ensuring output from the vessel. US 5,736,005 reveals a variant of such a hollow shaft in which fluid is added to a continuous digester with the aim of ensuring output from the digester.

[0004] An alternative to the above-described addition of fluid with the aim of diluting and ensuring output of the pulp or chips from the digester or the impregnation vessel is to add the fluid at the lower part of the vessel through a fluid supply device through the vessel. It is preferable that this addition takes place in the vicinity of the scraper device. SE 180 289 reveals an embodiment in which the fluid supply device adds fluid close to the bottom of a container with the aim of preventing the formation of blockages of cellulose fibres.

[0005] Addition of fluid by the methods that have been described above, however, involves a number of disadvantages, particularly when the addition is made to an impregnation vessel.

[0006] In the cases in which the fluid is added to an impregnation vessel, the extra addition of fluid must be dealt with by the top separator in subsequent digesters, which involves a considerable extra expense at the top separator. Furthermore, the added fluid involves large volumes of fluid that the system must deal with, and this in turn involves expensive investment and high operating costs of pumps and high-pressure taps, or both.

[0007] The same problem arises, naturally, also in

those cases in which no fluid has been added at the bottom of the impregnation vessel due to the fluid/wood ratio of the chips suspension being so high that it is not necessary to add fluid in order to ensure output from the impregnation vessel.

The Aims of the Invention

[0008] The principal aim of the present invention is to either eliminate or reduce the above-described problems and disadvantages in association with the output of cellulose pulp from an impregnation vessel to a transfer line, where the invention allows:

- a reduction in the amount of fluid in the chips suspension that is fed out from the impregnation vessel to the digester, i.e. a reduction in the fluid/wood ratio;
- the ability initially to establish a stable flow out from the bottom of the impregnation vessel with only instantaneously increased fluid volumes, or the opportunity for increased dilution in the bottom of the impregnation vessel without the increased amounts of fluid needing for this reason to be pumped onwards into the transfer line;
- the ability to use a smaller and cheaper top separator in subsequent digesters as a consequence of the lower volumes of fluid, and preferably the ability to eliminate completely a top separator;
- the ability to use smaller and cheaper pumps or high-pressure taps, or both, that consume lower power, due to the lower volumes of fluid.

[0009] These aims are achieved with an arrangement according to claim 1.

Brief Description of Drawings

[0010] The invention will be described in more detail below with the aid of the attached drawings, of which:

Figure 1 shows one preferred embodiment of an impregnation vessel in which the arrangement according to the invention is included.

Figure 2a shows a side view with a section A-A and Figure 2b shows a top view of a first preferred embodiment of the bucket-shaped outlet 201,

Figure 3a shows a side view with a section B-B and Figure 3b shows a top view of a second preferred embodiment of the bucket-shaped outlet 201,

Figure 4a shows a side view and Figure 4b shows a top view of a third preferred embodiment of the bucket-shaped outlet 201,

Figure 5a shows a side view with a section C-C and Figure 5b shows a top view of a fourth preferred em-

bodiment of the bucket-shaped outlet 201 and outlet line 301,

Figure 6a, 6b and 6c show different embodiments of the appearance of different strainer surfaces of the bucket-shaped outlet.

Figure 7 shows an embodiment of how scraper arms 207 are arranged around shaft 106 in order to maintain the holes or slits in the strainer clean.

Figure 8 shows an embodiment of a variant of the embodiment in Figure 4, in which a debris trap is arranged under the bottom surface.

Detailed Description of the Invention

[0011] The concept "chips suspension" will be used in the following detailed description of the invention. This term is here used to denote chips together with fluid, which suspension is treated in an impregnation vessel and fed out from the said impregnation vessel to a subsequent digester in a continuous cooking process for the production of cellulose pulp.

[0012] A further expression that will be used is "fluid/wood ratio". This expression is here used to denote the relationship between fluid and wood that is prevalent in the chips suspension.

[0013] Furthermore, the expression "perforated strainer hole or slit" will be used in the description of strainer surfaces. This expression is here used to denote penetrating openings in the surface with no requirements placed on their shape. Thus, these openings may be round, square, triangular, etc. Furthermore, it is also possible to conceive that the perforations consist of penetrating slits that may be straight, bent, curved, etc.

[0014] Finally, the concept "feed device" will be used. This term is here used to denote a device that is intended to feed the chips suspension from an impregnation vessel to a digester by the application of pressure. Examples of such feed devices are pumps and high-pressure taps.

[0015] Figure 1 shows the lower part of a principally cylindrical vertically arranged impregnation vessel 101 for the impregnation of chips, which impregnation vessel precedes a digester 401 in a continuous cooking process for the production of chemical cellulose pulp. The impregnation vessel has a diameter D_1 , an inlet 107 at the top of the vessel into which untreated chips are fed, and a bucket-shaped outlet 201 at the bottom of the vessel from which a chips suspension, i.e. impregnated chips with fluid, is fed out. The chips suspension in the impregnation vessel has a first fluid/wood ratio, which first fluid/wood ratio preferably lies within the interval 2-7.

[0016] In order to facilitate the output of the chips suspension from the impregnation vessel 101, a mechanical stirrer 102 is arranged at the bottom of the impregnation vessel 101, in order to obtain stirring of the chips suspension. The stirrer 102 comprises a number of scraper

arms 105, preferably two, that are arranged at the upper end of a shaft 106 that is vertically arranged. The shaft 106 is driven at its lower end by means of a directly acting driver device 107. The stirring of the chips suspension breaks the orientation of the chips in association with the output process, such that the output from the impregnation vessel is facilitated.

[0017] In order to ensure further the output of the chips suspension from the impregnation vessel 101, dilution fluid is added in a known manner in an amount of Q_1 in the vicinity of the bottom by means of at least one dilution fluid supply nozzle 103. The dilution fluid supply nozzles 103 are most often arranged through the wall of the impregnation vessel 101 or in the scraper arms 105. In the embodiment in which the dilution fluid supply nozzles 103 are arranged in the scraper arms 105, the shaft 106 (not shown in the drawing) through which fluid flows. The total amount of dilution fluid that is added to the impregnation vessel 101 from the dilution fluid supply nozzles 103 will hereafter be referred to as Q_1 . The chips suspension after the addition of the dilution fluid has a second fluid/wood ratio, which is higher than the first fluid/wood ratio further up in the impregnation vessel, which second fluid/wood ratio is established in order to ensure an even output that is free of disturbances. This second fluid/wood ratio preferably lies in the interval 6-10. Operating conditions can, however, occur in which $Q_1=0$, i.e. no dilution fluid is added through the dilution fluid supply nozzles 103, and in the cases in which the first and the second fluid/wood ratios are equal, this ratio lies in the interval 6-10.

[0018] In order to summarise briefly the relationship between the first and the second fluid/wood ratios, it can be stated that the chips suspension in the vessel 101 has the first fluid/wood ratio established above the second fluid/wood ratio, where the second fluid/wood ratio is established at the bottom of the vessel. The second fluid/wood ratio is at least as large as the first fluid/wood ratio, preferably larger.

[0019] The chips suspension, i.e. the impregnated chips together with the fluid, is continuously fed out from the impregnation vessel 101 through a bucket-shaped outlet 201 arranged in and under the bottom of the impregnation vessel 101 below the scraper device 102. The bucket-shaped outlet 201 has a diameter D_2 that is less than the diameter of the impregnation vessel D_1 , i.e. $D_2 < D_1$. The diameter D_2 of the bucket-shaped outlet is approximately 1-1.5 m for an impregnation vessel 101 with a diameter D_1 of 3-5 m. For an impregnation vessel with a diameter D_1 of 10 m, D_2 can have a dimension of approximately 2 m. The diameter D_2 is thus less than 50% of D_1 and preferably in the interval 15-40% of D_1 . Parts of the wall of the bucket-shaped outlet, or the complete wall, consist of perforated strainer holes or slits. The strainer holes or slits are surrounded by a withdrawal space 206 at the outer wall of the outlet from which withdrawal space 206 the partial fluid volume Q_2 is withdrawn

from the chips suspension by means of a pump 303, before the remainder of the chips suspension is sent in the outlet line 301 to subsequent digesters 401 through being placed under pressure by a pressure device 302. The outlet line 301 is connected to the wall section of the bucket-shaped outlet, which outlet line 301 has a diameter D_3 , where $D_1 > D_2 > D_3$. The chips suspension after the withdrawal of fluid has a third fluid/wood ratio, which is lower than the second fluid/wood ratio. This third fluid/wood ratio lies in the interval 5-9, and is at least 1 unit, preferably at least 2 units, lower than the second fluid/wood ratio, which lies in the interval 6-10.

[0020] The withdrawn fluid Q2 can then be sent to any one or to a combination of the following:

- Q2 is sent in a circulation line that is connected at its first inlet end to at least one withdrawal space (206) arranged at the bucket-shaped outlet (201) and where a second end of the circulation line is connected to a recovery process (REC). A natural position if it is desired to withdraw consumed impregnation fluid, which in turn has been partly constituted by a withdrawal from the digester.
- Q2 is sent in a circulation line that is connected at its first inlet end to at least one withdrawal space (206) arranged at the bucket-shaped outlet (201) and where a second end of the circulation line is connected to a dilution fluid supply nozzle (103). In this case it is solely a question of a local dilution.
- Q2 is sent in a circulation line that is connected at its first inlet end to at least one withdrawal space (206) and where the second end of the circulation line is connected to a position (A) close to the top of the impregnation vessel (101).
- Q2 is sent in a circulation line that is connected at its first inlet end to at least one withdrawal space (206) and where the second end of the circulation line is connected to a position (B) in a subsequent digester (401). This is done with the aim of, if it is desired at any cooking phase, to modify the digestion conditions, possibly to raise the sulphidity, or to initiate precipitation of early dissolved XYLAN onto the fibres in the digester.

[0021] Figures 2a and 2b show a first preferred embodiment of the bucket-shaped outlet 201 where parts of, and preferably the complete, surface 204 of the outlet is perforated with strainer holes or slits 205, and from which perforated surface 204 a fraction Q2 of the fluid in the chips suspension is withdrawn with a pump 303 through a withdrawal space 206 arranged around the strainer holes or slits of the outer surface 204. The shaft 106 (not shown in this drawing) passes through a penetrating opening 202 in the bucket-shaped outlet 201.

[0022] Figures 3a and 3b show a second preferred embodiment of the bucket-shaped outlet 201 where the surface 204 of the outlet 201 is perforated with strainer holes

or slits 205 over a surrounding angle α between 90° and 270° , preferably 180° , and from which perforated surface 204 a fraction Q2 of the fluid in the chips suspension is withdrawn by a pump 303 through a withdrawal space 206 arranged around the strainer holes or slits of the outer surface 204. The shaft 106 (not shown in this drawing) passes through a penetrating opening 202 in the bucket-shaped outlet 201.

[0023] Figures 4a and 4b show a third preferred embodiment of the bucket-shaped outlet 201 where the outlet has a bottom surface 203. Parts of or, preferably, the complete bottom surface 203 are perforated with strainer holes or slits 205. From the perforated bottom surface 203 a fraction Q2 of the fluid in the chips suspension is withdrawn by a pump 303 through a withdrawal space 206. The shaft 106 (not shown in this drawing) passes through a penetrating opening 202 in the bucket-shaped outlet 201.

[0024] Figures 5a and 5b show a fourth preferred embodiment where the surface of the outlet line 302 is partially or fully perforated strainer holes or slits 205. From the perforated surface a fraction Q2 of the fluid in the chips suspension is withdrawn by a pump 303 through a withdrawal space 206 arranged around the perforated strainer holes or slits 205 in the outer surface of the outlet line.

[0025] Figure 6a shows a fifth preferred embodiment of how the strainer surface of the bucket-shaped outlet, which consists of strainer holes or slits 205, may appear. The complete surface is perforated in this case.

[0026] Figure 6b shows a sixth preferred embodiment in which parts of the strainer surface are perforated by strainer holes or slits 205.

[0027] Figure 6c shows a seventh preferred embodiment in which parts of the strainer surface are perforated with strainer holes or slits 205.

[0028] Figures 7a and 7b shows a side view and a top view of the bucket-shaped outlet 201 where scraper arms 207 have been arranged on a shaft 106 with the aim of maintaining the strainer holes or slits in the strainer surfaces of the bucket-shaped outlet clean, such that they do not become clogged.

[0029] Figures 8a and 8b show an eighth preferred embodiment of the bucket-shaped outlet 201 where the outlet has a bottom surface 203, similar to that shown in Figures 4a and 4b. Parts of, preferably the complete, bottom surface 203 are perforated with strainer holes or slits 205. From the perforated bottom surface a fraction Q2 of fluid is withdrawn from the chips suspension with the pump 303 through the withdrawal space 206. An outlet 801 is present in the bottom surface 203 with a space arranged under the bottom surface. Sluice valves 802 are arranged in the space of the outlet, which valves can be emptied of coarse material 804 that collects in this space during operation. It is an advantage if the outlet is arranged in the vicinity of the outlet line 301, since the chips suspension passes the outlet, such that the heavy or coarse material falls down into the outlet 801. It is an

advantage if a fluid line 803 is arranged after the pump 303 at the space in the outlet 803. In this way, output from the outlet 803 is facilitated, in that a dilution is achieved. The scraper arms 207, which are shown in Figure 7, aid in transporting the material 804 to the outlet 801.

[0030] The following advantages, among others, are achieved with the invention, compared with conventional technology described above as the prior art:

■ A reduced flow of fluid to the top separator of the digester from the preceding impregnation vessel, which results in the ability to use a smaller and cheaper top separator. It is possible with an optimal embodiment to dispense completely with the top separator on the digester.

■ a reduced fluid content of the chips suspension that leaves the impregnation vessel, which results in the ability to use smaller, cheaper and less energy-consuming pumps or high-pressure taps, or both.

[0031] The invention is not limited to the embodiments described: several variants are possible within the scope of the attached patent claims. All of the following combinations, for example, are possible, individually or in combination:

- 1) strainer holes or slits 205 at a location on the outer surface 204 of the bucket-shaped outlet
- 2) strainer holes or slits 205 at a location on the bottom surface 203 of the bucket-shaped outlet
- 3) strainer holes or slits 205 in the outer surface 301 of the line.

Claims

1. An arrangement for the feed of a chips suspension from a vessel to a subsequent digester in a continuous cooking process for the production of chemical cellulose pulp, where the arrangement comprises,
 - a vessel (101) arranged essentially vertically with an inlet (107) for the feed in of chips and an outlet (201) for the feed out of chips;
 - an outlet line (301) connected to the outlet, in order to transport the chips suspension to a subsequent digester (401) by means of placing it under pressure with a pressure device (302), **characterised in**
 - **that** the vessel (101) has a diameter D1, the outlet (201) has a diameter D2 and the outlet line (301) has a diameter D3, and where the relationships between the diameters follows $D1 > D2 > D3$.
 - **that** at least a part of the outlet (201) before the feed device (302) is perforated with strainer holes or slits.

- **that** a fraction Q2 of the fluid in the diluted chips suspension is withdrawn from the strainer holes or slits (205) in the outlet before the remaining chips suspension is placed under pressure by means of the feed device (302) and sent to the subsequent digester (401) through the transport line (301).

2. The arrangement according to claim 1, **characterised in that** a stirrer (102) is arranged at the bottom of the vessel (101) for stirring the chips suspension.
3. The arrangement according to either claim 1 or 2, **characterised in that** a withdrawal space (206) is arranged on the outside of the outlet (201), and where the fraction Q2 is withdrawn from the strainer holes or slits (205) through the withdrawal space (206) by means of a pump (303).
4. The arrangement according to any one of claims 1-3, **characterised in that** at least one dilution fluid supply nozzle (103) is arranged in the vicinity of the bottom of the vessel (101), which nozzle (103) adds dilution fluid to the said vessel (101) at an amount of Q1.
5. The arrangement according to any one of claims 1-5, **characterised in that** the outlet (201) has the form of a cylindrical bucket.
6. The arrangement according to any one of claims 1-5, **characterised in that** at least a part of the outer surface (204) of the bucket-shaped outlet is perforated with strainer holes or slits, from which perforated outer surface (204) a fraction Q2 of the fluid of the chips suspension is withdrawn.
7. The arrangement according to any one of claims 1-6, **characterised in that** at least a part of the outer surface (204) of the bucket-shaped outlet is perforated with an angle of inclusion between 90 and 270 °, preferably 180 °, from which perforated outer surface (204) a fraction Q2 of the fluid of the chips suspension is withdrawn.
8. The arrangement according to any one of claims 1-7, **characterised in that** at least a part of the bottom surface (203) of the bucket-shaped outlet is perforated with strainer holes or slits (205), from which perforated bottom surface (203) a fraction of the fluid of the chips suspension is withdrawn.
9. The arrangement according to any one of claims 1-8, **characterised in that** the outlet line (301) connected to the of the bucket-shaped outlet is provided with perforating holes or slits (205) on at least a part of its outer surface, from which perforated holes or slits (205) a fraction Q2 of the fluid of the chips suspen-

sion is withdrawn.

10. The arrangement according to any one of the above claims 1-9, **characterised in that** a circulation line is connected at its first input end to at least one withdrawal space (206) arranged at the bucket-shaped outlet (201) and where a second end of the circulation line is connected to the recovery system (REC).
11. The arrangement according to any one of claims 1-10, **characterised in that** a circulation line is connected at its first input end to at least one withdrawal space (206) arranged at the bucket-shaped outlet (201) and where a second end of the circulation line is connected to dilution fluid supply nozzles (103).
12. The arrangement according to any one of the above claims 1-11, **characterised in that** a circulation line is connected at its first input end to at least one withdrawal space (206) and where the second end of the circulation line is connected to a position (A) close to the top of the vessel (101).
13. The arrangement according to any one of the above claims 1-12, **characterised in that** a circulation line is connected at its first input end to at least one withdrawal space (206) and where the second end of the circulation line is connected to a position B in a subsequent digester (401).
14. The arrangement according to any one of claims 1-13, **characterised in that** an outlet is arranged in the bottom surface (203) of the bucket-shaped outlet with a space arranged under the bottom surface, which space can be emptied through sluices of coarse material that collects in the space during operation.

Patentansprüche

1. Anordnung zum Speisen einer Schnitzelsuspension von einem Gefäß zu einem nachfolgenden Kocher in einem kontinuierlichen Kochprozess zur Erzeugung eines chemischen Zellstoffs, wobei die Anordnung Folgendes umfasst:
- ein Gefäß (101), das im Wesentlichen vertikal mit einem Einlass (107) für die Einspeisung von Schnitzeln und einem Auslass (201) für die Ausspeisung von Schnitzeln angeordnet ist;
 - eine Auslassleitung (301), die mit dem Auslass verbunden ist, um die Schnitzelsuspension zu einem nachfolgenden Kocher (401) zu befördern, indem sie mit einer Druckvorrichtung (302) mit Druck beaufschlagt wird, **dadurch gekennzeichnet, dass**
 - das Gefäß (101) einen Durchmesser D1 auf-

weist, der Auslass (201) einen Durchmesser D2 aufweist und die Auslassleitung (301) einen Durchmesser D3 aufweist, und wobei die Beziehungen zwischen den Durchmessern $D1 > D2 > D3$ sind,

- mindestens ein Teil des Auslasses (201) vor der Speisevorrichtung (302) mit Sieblöchern oder -schlitzen perforiert ist,
- ein Bruchteil Q2 des Fluids in der verdünnten Schnitzelsuspension aus den Sieblöchern oder -schlitzen (205) im Auslass abgezogen wird, bevor die verbleibende Schnitzelsuspension mittels der Speisevorrichtung (302) mit Druck beaufschlagt wird und durch die Förderleitung (301) zu dem nachfolgenden Kocher (401) geschickt wird.

2. Anordnung nach Anspruch 1, **dadurch gekennzeichnet, dass** ein Rührer (102) am Boden des Gefäßes (101) zum Rühren der Schnitzelsuspension angeordnet ist.
3. Anordnung nach Anspruch 1 oder 2, **dadurch gekennzeichnet, dass** ein Abziehraum (206) auf der Außenseite des Auslasses (201) angeordnet ist, und wobei der Bruchteil Q2 aus den Sieblöchern oder -schlitzen (205) mittels einer Pumpe (303) durch den Abziehraum (206) abgezogen wird.
4. Anordnung nach einem der Ansprüche 1 - 3, **dadurch gekennzeichnet, dass** mindestens eine Verdünnungsfluidzufuhrdüse (103) in der Nähe des Bodens des Gefäßes (101) angeordnet ist, wobei die Düse (103) dem Gefäß (101) Verdünnungsfluid in einer Menge von Q1 zuführt.
5. Anordnung nach einem der Ansprüche 1 - 5, **dadurch gekennzeichnet, dass** der Auslass (201) die Form eines zylindrischen Eimers aufweist.
6. Anordnung nach einem der Ansprüche 1 - 5, **dadurch gekennzeichnet, dass** zumindest ein Teil der Außenfläche (204) des eimerförmigen Auslasses mit Sieblöchern oder -schlitzen perforiert ist, wobei von dieser perforierten Außenfläche (204) ein Bruchteil Q2 des Fluids der Schnitzelsuspension abgezogen wird.
7. Anordnung nach einem der Ansprüche 1 - 6, **dadurch gekennzeichnet, dass** mindestens ein Teil der Außenfläche (204) des eimerförmigen Auslasses mit einem Einschlusswinkel zwischen 90° und 270° , vorzugsweise 180° , perforiert ist, wobei von dieser perforierten Außenfläche (204) ein Bruchteil Q2 des Fluids der Schnitzelsuspension abgezogen wird.
8. Anordnung nach einem der Ansprüche 1 - 7, **da-**

durch gekennzeichnet, dass mindestens ein Teil der Unterseite (203) des eimerförmigen Auslasses mit Sieblöchern oder -schlitzen (250) perforiert ist, wobei von dieser perforierten Unterseite (203) ein Bruchteil des Fluids der Schnitzelsuspension abgezogen wird.

9. Anordnung nach einem der Ansprüche 1 - 8, **dadurch gekennzeichnet, dass** die Auslassleitung (301), die mit dem Wandabschnitt des eimerförmigen Auslasses verbunden ist, an mindestens einem Teil seiner Außenfläche mit Perforationslöchern oder -schlitzen (205) versehen ist, wobei aus diesen perforierten Löchern oder Schlitzen (205) ein Bruchteil Q2 des Fluids der Schnitzelsuspension abgezogen wird.
10. Anordnung nach einem der obigen Ansprüche 1 - 9, **dadurch gekennzeichnet, dass** eine Zirkulationsleitung an ihrem ersten Eingangsende mit mindestens einem Abziehraum (206) verbunden ist, der an dem eimerförmigen Auslass (201) angeordnet ist, und wobei ein zweites Ende der Zirkulationsleitung mit dem Rückgewinnungssystem (REC) verbunden ist.
11. Anordnung nach einem der Ansprüche 1 - 10, **dadurch gekennzeichnet, dass** eine Zirkulationsleitung an ihrem ersten Eingangsende mit mindestens einem Abziehraum (206) verbunden ist, der an dem eimerförmigen Auslass (201) angeordnet ist, und wobei ein zweites Ende der Zirkulationsleitung mit den Verdünnungsfluidzufuhrdüsen (103) verbunden ist.
12. Anordnung nach einem der obigen Ansprüche 1 - 11, **dadurch gekennzeichnet, dass** eine Zirkulationsleitung an ihrem ersten Eingangsende mit mindestens einem Abziehraum (206) verbunden ist, und wobei das zweite Ende der Zirkulationsleitung nahe der Oberseite des Gefäßes (101) mit einer Stelle (A) verbunden ist.
13. Anordnung nach einem der obigen Ansprüche 1 - 12, **dadurch gekennzeichnet, dass** eine Zirkulationsleitung an ihrem ersten Eingangsende mit mindestens einem Abziehraum (206) verbunden ist, und wobei das zweite Ende der Zirkulationsleitung mit einer Stelle B in einem nachfolgenden Kocher (401) verbunden ist.
14. Anordnung nach einem der Ansprüche 1 - 13, **dadurch gekennzeichnet, dass** ein Auslass in der Unterseite (203) des eimerförmigen Auslasses mit einem unter der Unterseite angeordneten Raum angeordnet ist, wobei der Raum durch Schleusen von grobem Material, das sich im Betrieb in dem Raum ansammelt, gereinigt werden kann.

Revendications

- Dispositif permettant d'apporter une suspension de copeaux d'un récipient à un digesteur suivant dans un procédé de cuisson continu afin de produire de la pulpe de cellulose chimique, dans lequel le dispositif comprend:
 - un récipient (101) qui est agencé essentiellement verticalement et comporte une entrée (107) pour l'arrivée de copeaux, et une sortie (201) pour la sortie des copeaux; et
 - une ligne de sortie (301) qui est connectée à la sortie, dans le but de transporter la suspension de copeaux jusqu'à un digesteur suivant (401) en la mettant sous pression à l'aide d'un dispositif de pressurisation (302),

caractérisé en ce que:

 - le récipient (101) présente un diamètre D1, la sortie (201) présente un diamètre D2, et la ligne de sortie (301) présente un diamètre D3, et dans lequel la relation entre les diamètres est la suivante: $D1 > D2 > D3$;
 - au moins une partie de la sortie (201) avant le dispositif d'alimentation (302) est perforée avec des trous ou des fentes de crépine; et
 - une fraction Q2 du fluide dans la suspension de copeaux diluée est prélevée à partir des trous ou des fentes de crépine (205) dans la sortie avant que la suspension de copeaux restante soit mise sous pression à l'aide du dispositif d'alimentation (302), et est envoyée au digesteur suivant (401) à travers la ligne de transport (301).
- Dispositif selon la revendication 1, **caractérisé en ce qu'**un agitateur (102) est agencé au fond du récipient (101) pour agiter la suspension de copeaux.
- Dispositif selon la revendication 1 ou 2, **caractérisé en ce qu'**un espace de prélèvement (206) est agencé à l'extérieur de la sortie (201), dans lequel la fraction Q2 est prélevée à partir des trous ou des fentes de crépine (205) à travers l'espace de prélèvement (206) au moyen d'une pompe (303).
- Dispositif selon l'une quelconque des revendications 1 à 3, **caractérisé en ce qu'**au moins une buse d'alimentation de fluide de dilution (103) est agencée dans le voisinage du fond du récipient (101), ladite buse (103) ajoutant du fluide de dilution audit récipient (101) en une quantité Q1.
- Dispositif selon l'une quelconque des revendications 1 à 4, **caractérisé en ce que** la sortie (201) se présente sous la forme d'un godet cylindrique.
- Dispositif selon l'une quelconque des revendications

- 1 à 5, **caractérisé en ce qu'**au moins une partie de la surface extérieure (204) de la sortie en forme de godet est perforée avec des trous ou des fentes de crépine, surface extérieure perforée (204) à partir de laquelle une fraction Q2 du fluide de la suspension de copeaux est prélevée.
7. Dispositif selon l'une quelconque des revendications 1 à 6, **caractérisé en ce qu'**au moins une partie de la surface extérieure (204) de la sortie en forme de godet est perforée avec un angle d'inclusion qui est compris entre 90° et 270°, de préférence de 180°, surface extérieure perforée (204) à partir de laquelle une fraction Q2 du fluide de la suspension de copeaux est prélevée.
8. Dispositif selon l'une quelconque des revendications 1 à 7, **caractérisé en ce qu'**au moins une partie de la surface inférieure (203) de la sortie en forme de godet est perforée avec des trous ou des fentes de crépine (205), surface inférieure perforée (203) à partir de laquelle une fraction du fluide de la suspension de copeaux est prélevée.
9. Dispositif selon l'une quelconque des revendications 1 à 8, **caractérisé en ce que** la ligne de sortie (301) qui est connectée à la section de paroi de la sortie en forme de godet comporte des trous ou des fentes (205) de perforation sur au moins une partie de sa surface extérieure, trous ou fentes (205) perforé(e)s à partir desquel(le)s une fraction Q2 du fluide de la suspension de copeaux est prélevée.
10. Dispositif selon l'une quelconque des revendications 1 à 9, **caractérisé en ce qu'**une ligne de circulation est connectée à sa première extrémité d'entrée à au moins un espace de prélèvement (206) qui est agencé à la sortie en forme de godet (201), et où une deuxième extrémité de la ligne de circulation est connectée au système de récupération (REC).
11. Dispositif selon l'une quelconque des revendications 1 à 10, **caractérisé en ce qu'**une ligne de circulation est connectée à sa première extrémité d'entrée à au moins un espace de prélèvement (206) qui est agencé à la sortie en forme de godet (201) et où une deuxième extrémité de la ligne de circulation est connectée à des buses d'alimentation de fluide de dilution (103).
12. Dispositif selon l'une quelconque des revendications 1 à 11, **caractérisé en ce qu'**une ligne de circulation est connectée à sa première extrémité d'entrée à au moins un espace de prélèvement (206) et où la deuxième extrémité de la ligne de circulation est connectée à une position (A) proche du sommet du récipipient (101).
13. Dispositif selon l'une quelconque des revendications 1 à 12, **caractérisé en ce qu'**une ligne de circulation est connectée à sa première extrémité d'entrée à au moins un espace de prélèvement (206) et où la deuxième extrémité de la ligne de circulation est connectée à une position B dans un digesteur suivant (401).
14. Dispositif selon l'une quelconque des revendications 1 à 13, **caractérisé en ce qu'**une sortie est formée dans la surface inférieure (203) de la sortie en forme de godet avec un espace qui est prévu en dessous de la surface inférieure, ledit espace pouvant être vidé à travers des pertuis de décharge de matière grossière qui est collectée dans l'espace pendant le fonctionnement.

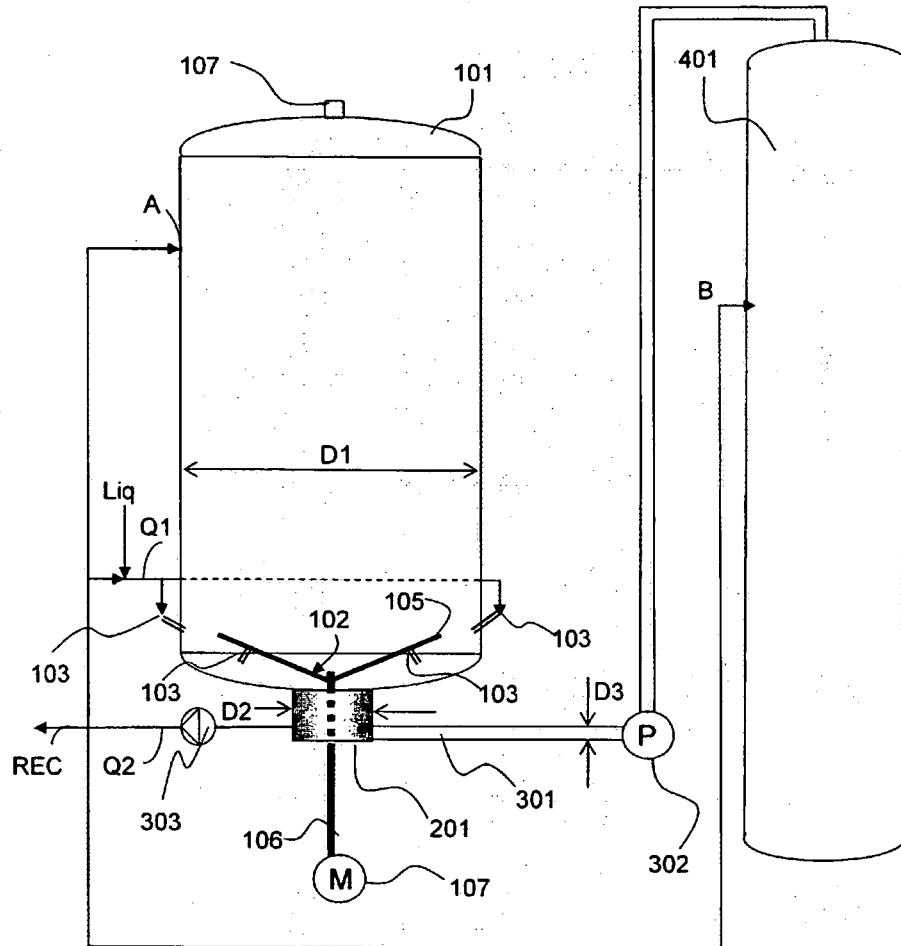

Fig. 1

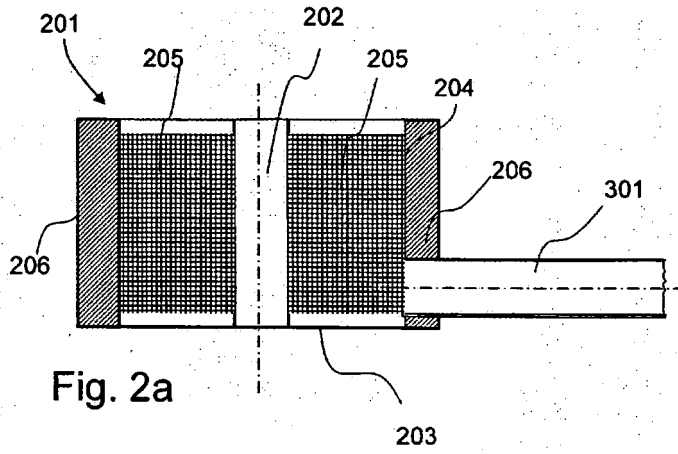

Fig. 2a

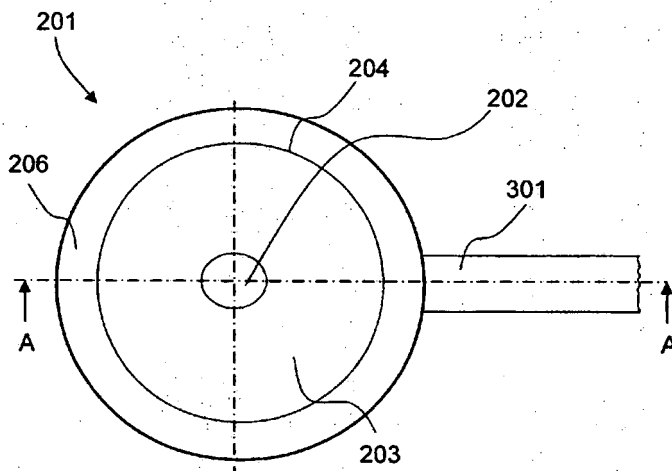
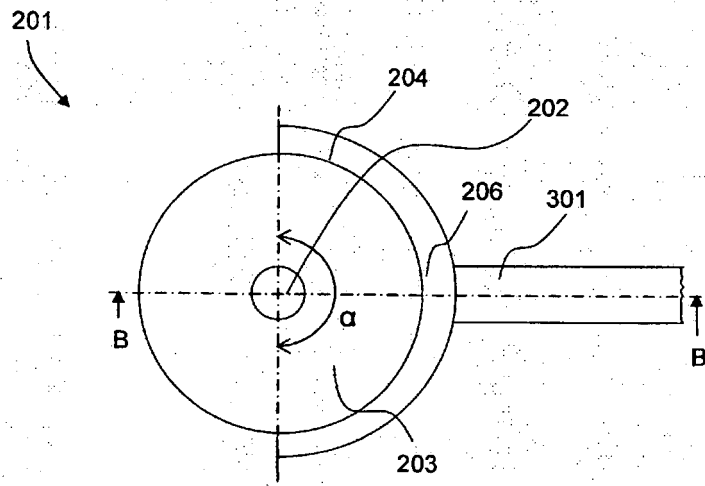
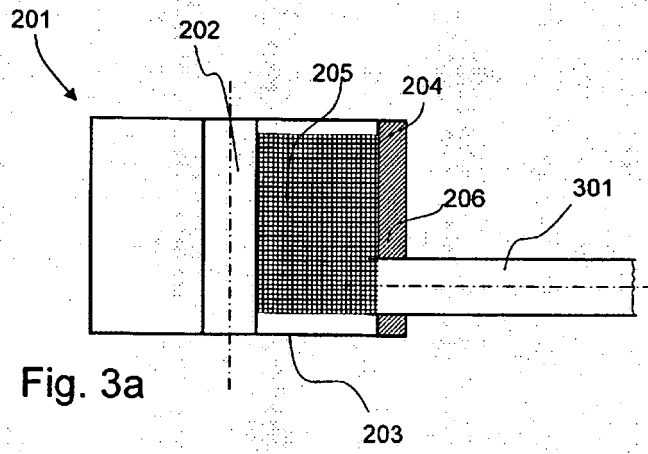
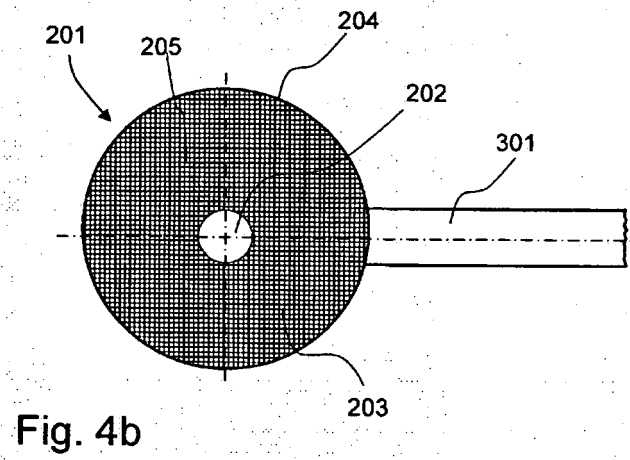
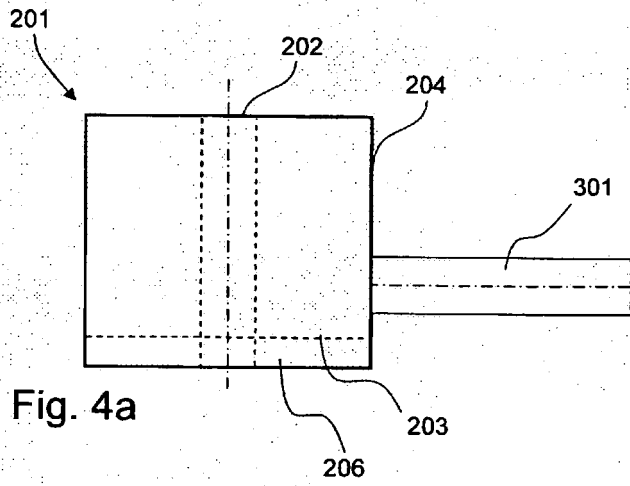
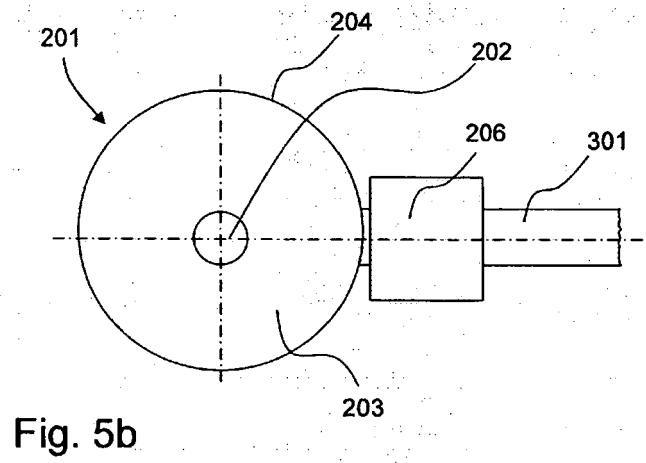
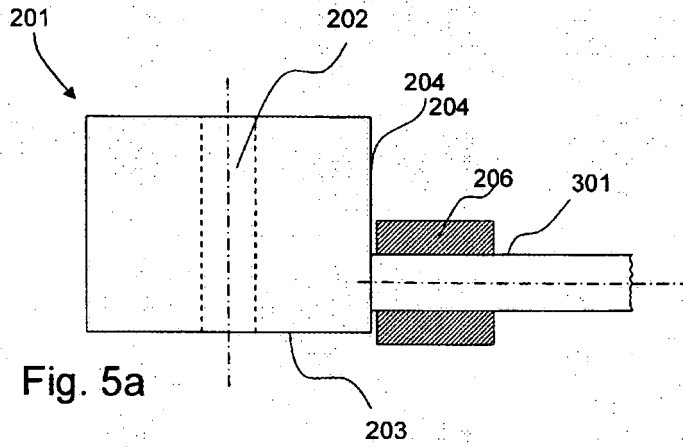

Fig. 2b







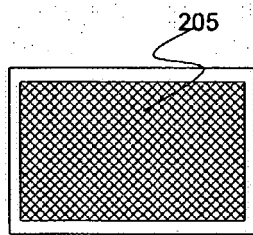

Fig. 6a

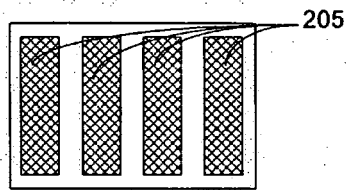

Fig. 6b

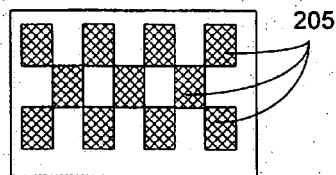

Fig. 6c

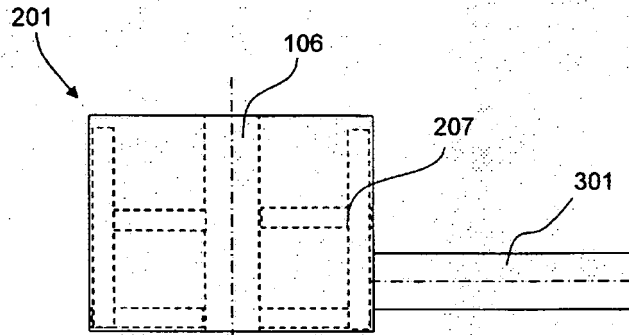

Fig. 7a

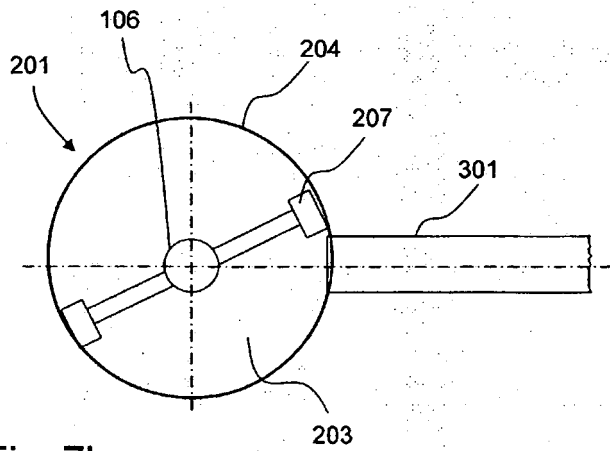
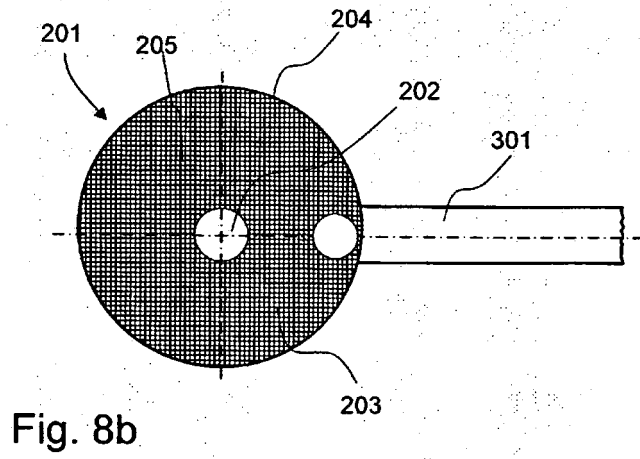
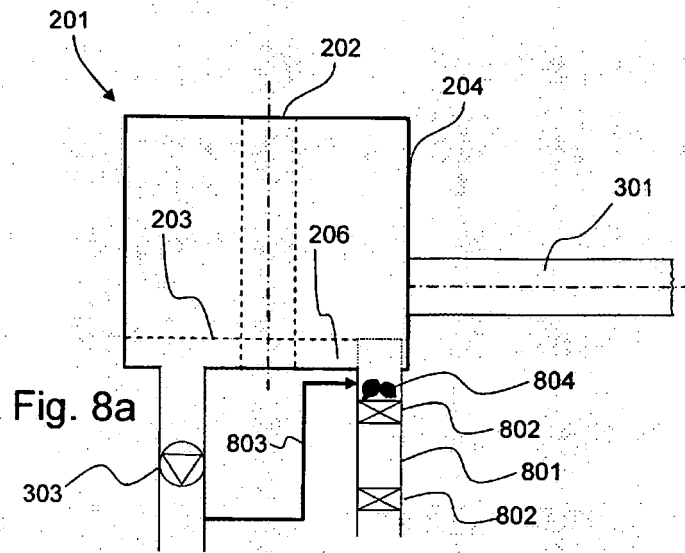

Fig. 7b



REFERENCES CITED IN THE DESCRIPTION

This list of references cited by the applicant is for the reader's convenience only. It does not form part of the European patent document. Even though great care has been taken in compiling the references, errors or omissions cannot be excluded and the EPO disclaims all liability in this regard.

Patent documents cited in the description

- US 5736005 A [0003]
- SE 180289 [0004]