



US 20130019913A1

(19) **United States**

(12) **Patent Application Publication**  
**Zadok et al.**

(10) **Pub. No.: US 2013/0019913 A1**

(43) **Pub. Date: Jan. 24, 2013**

(54) **COLLAPSIBLE PORTABLE SHELTER UNIT**

**Publication Classification**

(75) Inventors: **Yigal Zadok**, Ft. Lauderdale, FL (US);  
**Bryan Cole**, Port Saint Lucie, FL (US);  
**Jeffrey Strohecker**, Parkland, FL (US)

(51) **Int. Cl.**  
**E04H 15/48** (2006.01)  
**E04H 15/02** (2006.01)  
**E04H 15/56** (2006.01)

(73) Assignee: **Elite Aluminum Corporation**, Coconut Creek, FL (US)

(52) **U.S. Cl.** ..... **135/96; 135/116; 135/148**

(21) Appl. No.: **13/554,341**

(57) **ABSTRACT**

(22) Filed: **Jul. 20, 2012**

A collapsible portable shelter unit when in the collapsed mode is light and compact to make transport and storage convenient, but when opened provides an enclosed space that can be used for various purposes, which has an integrated high strength structured frame by the action of the interlocking extrusions which also provide resistance to water and wind infiltration. As needed, exterior windows and doors, air conditioning, electrical supply and other customization as required by the users' needs.

**Related U.S. Application Data**

(60) Provisional application No. 61/510,564, filed on Jul. 22, 2011.

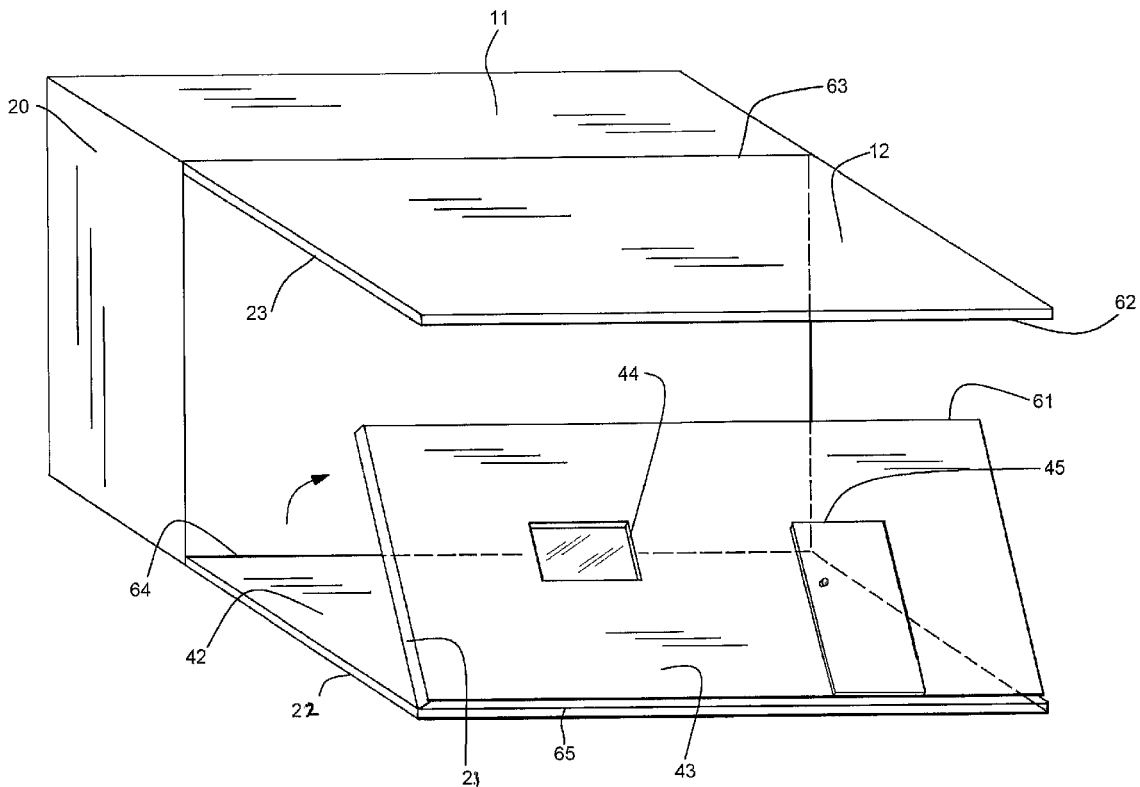

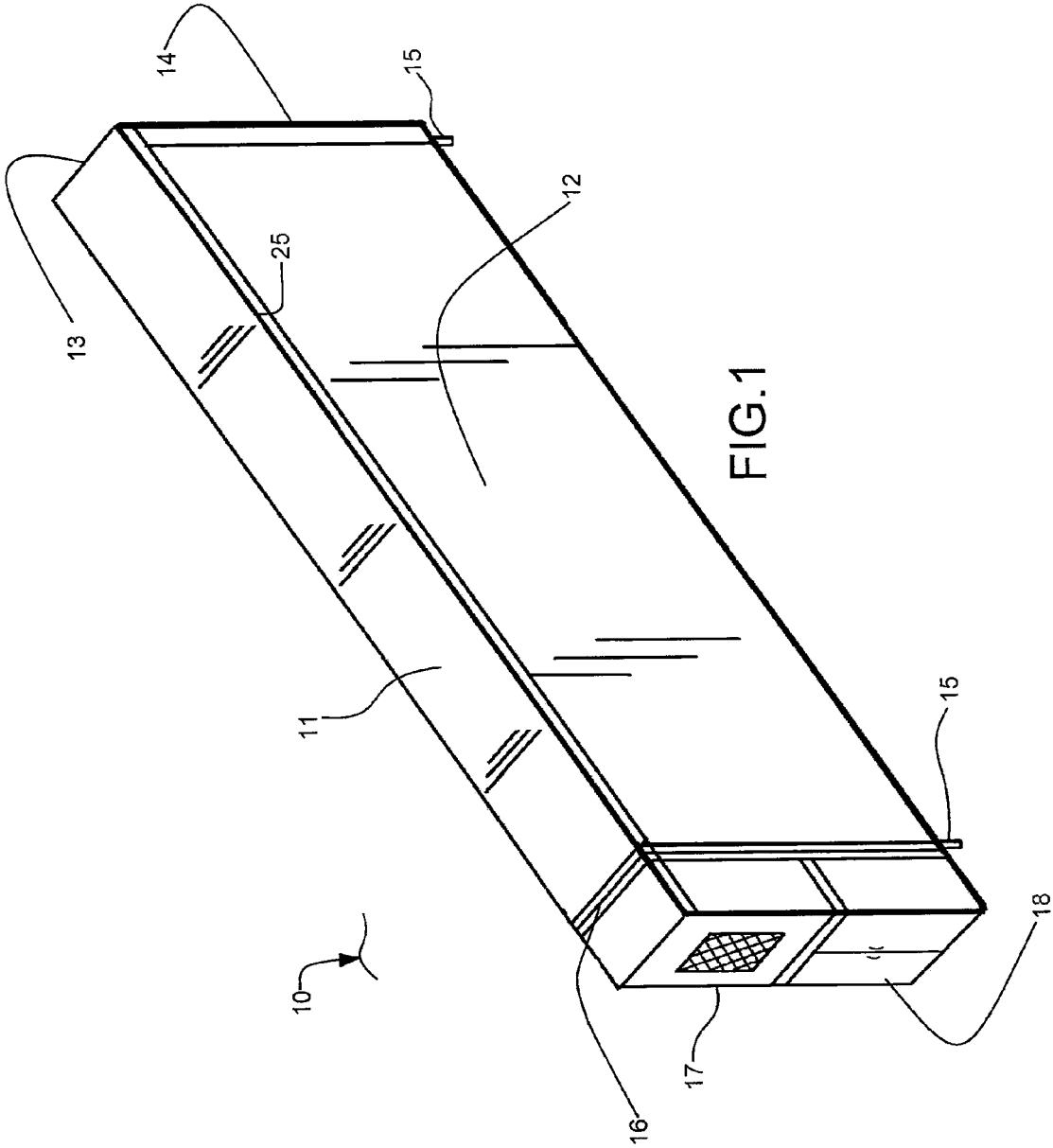

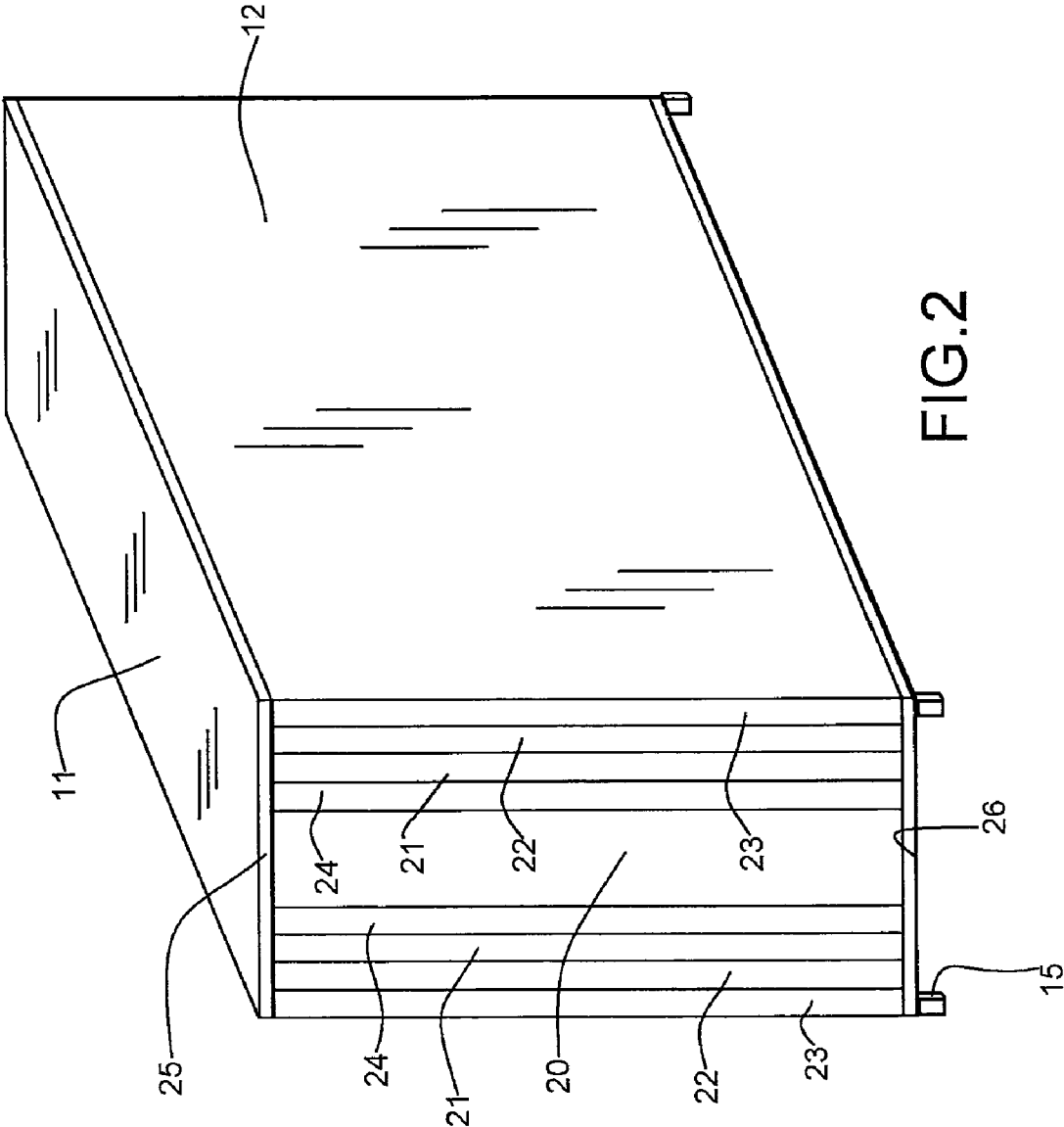

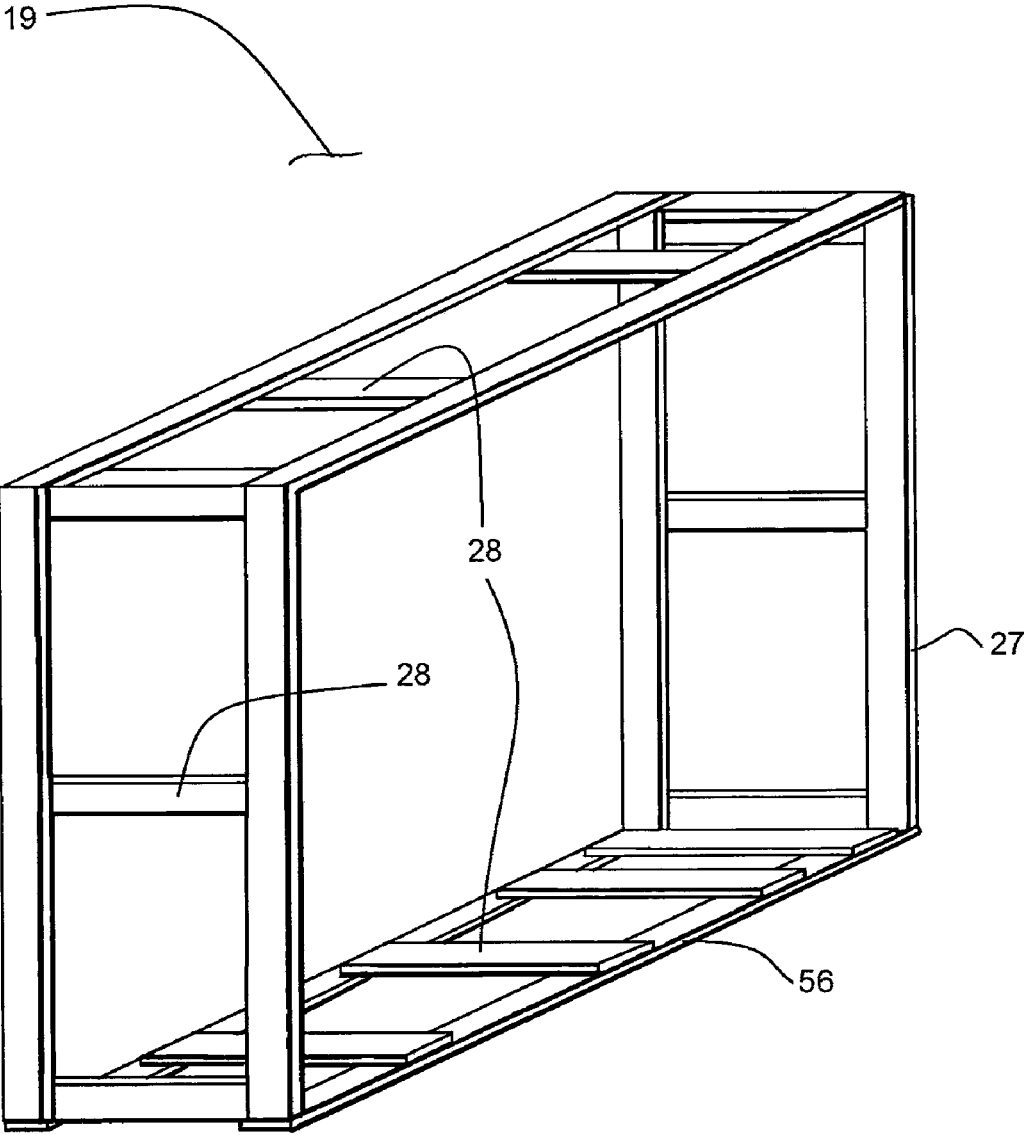

FIG.3

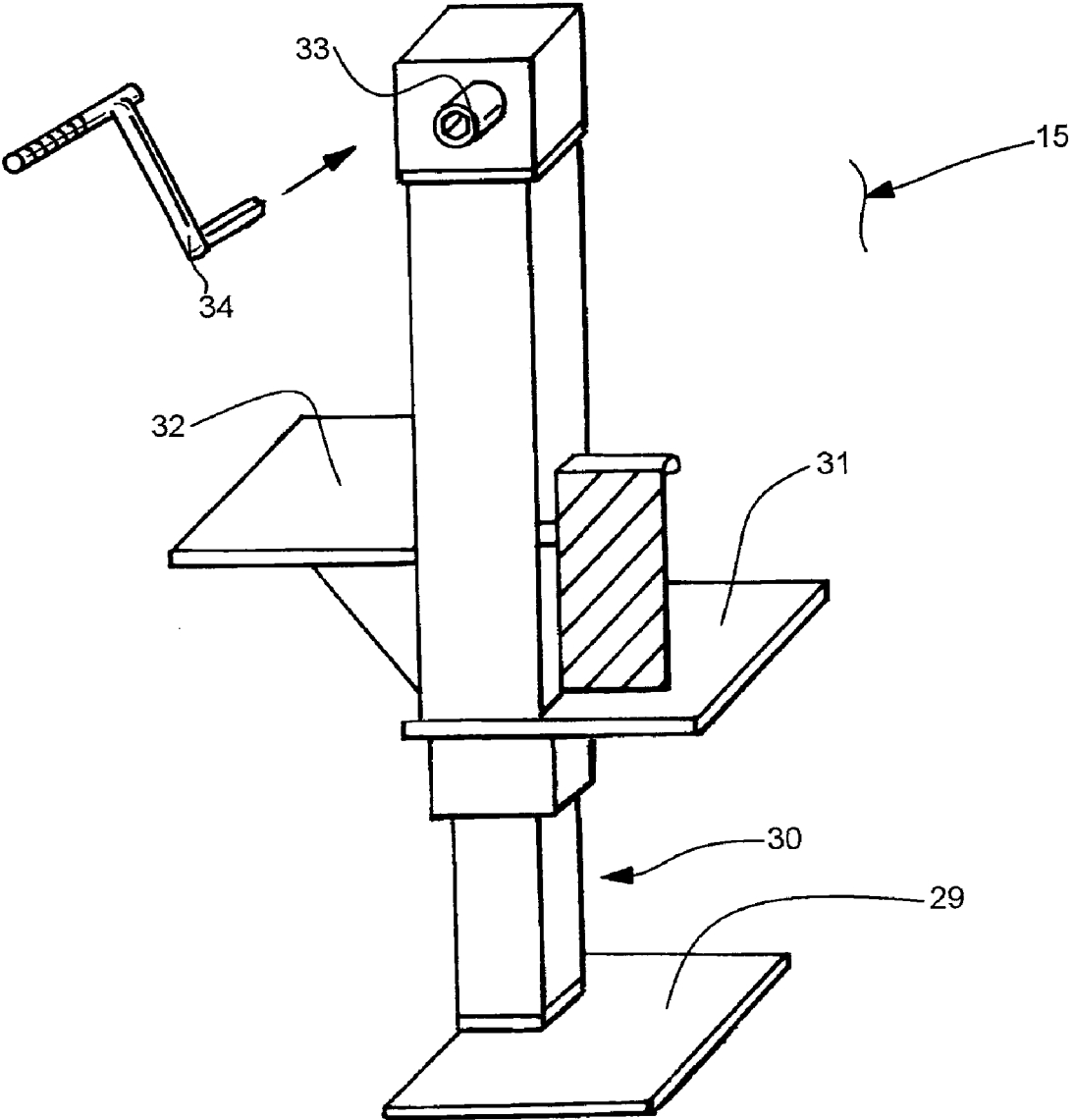
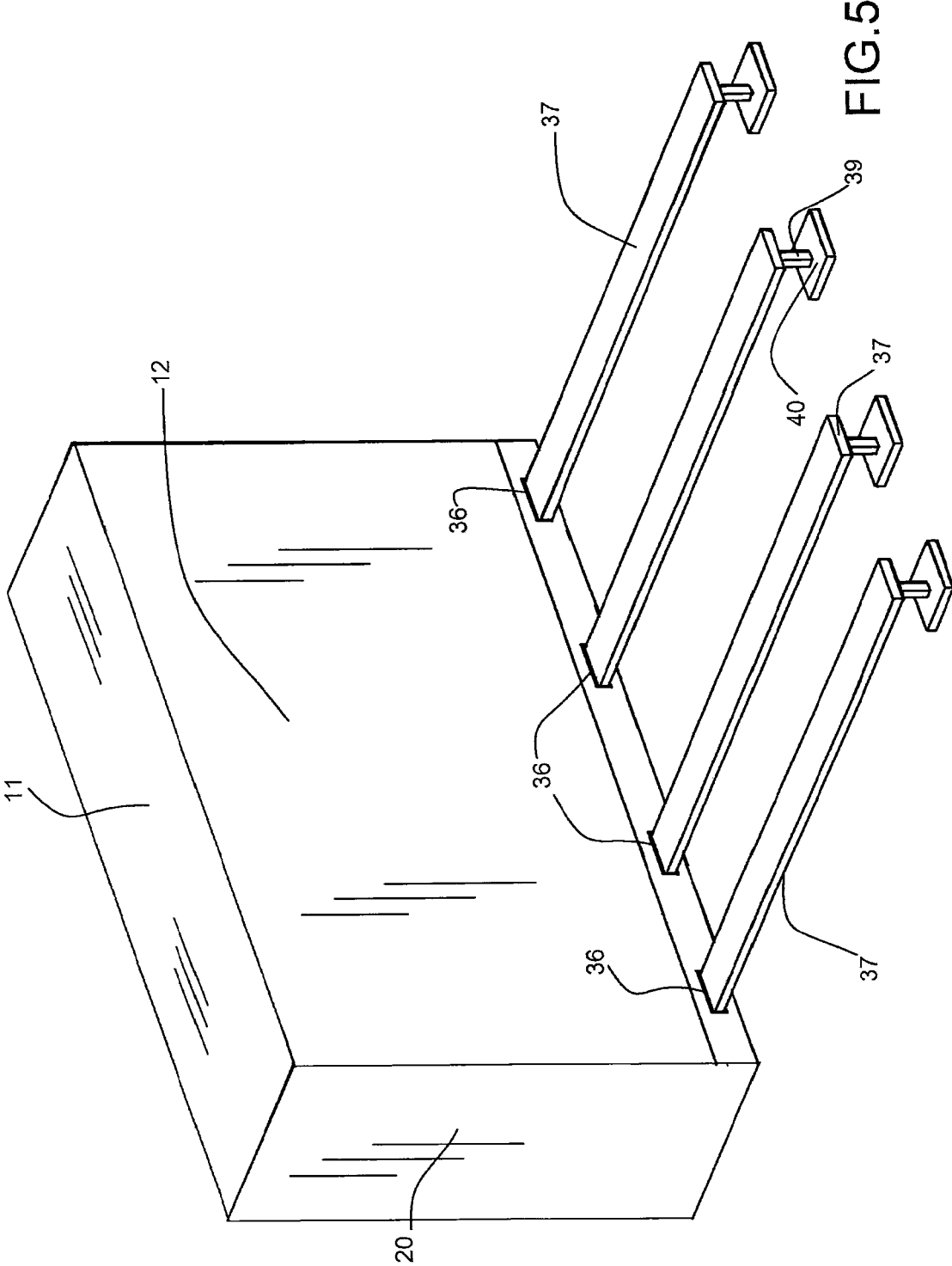
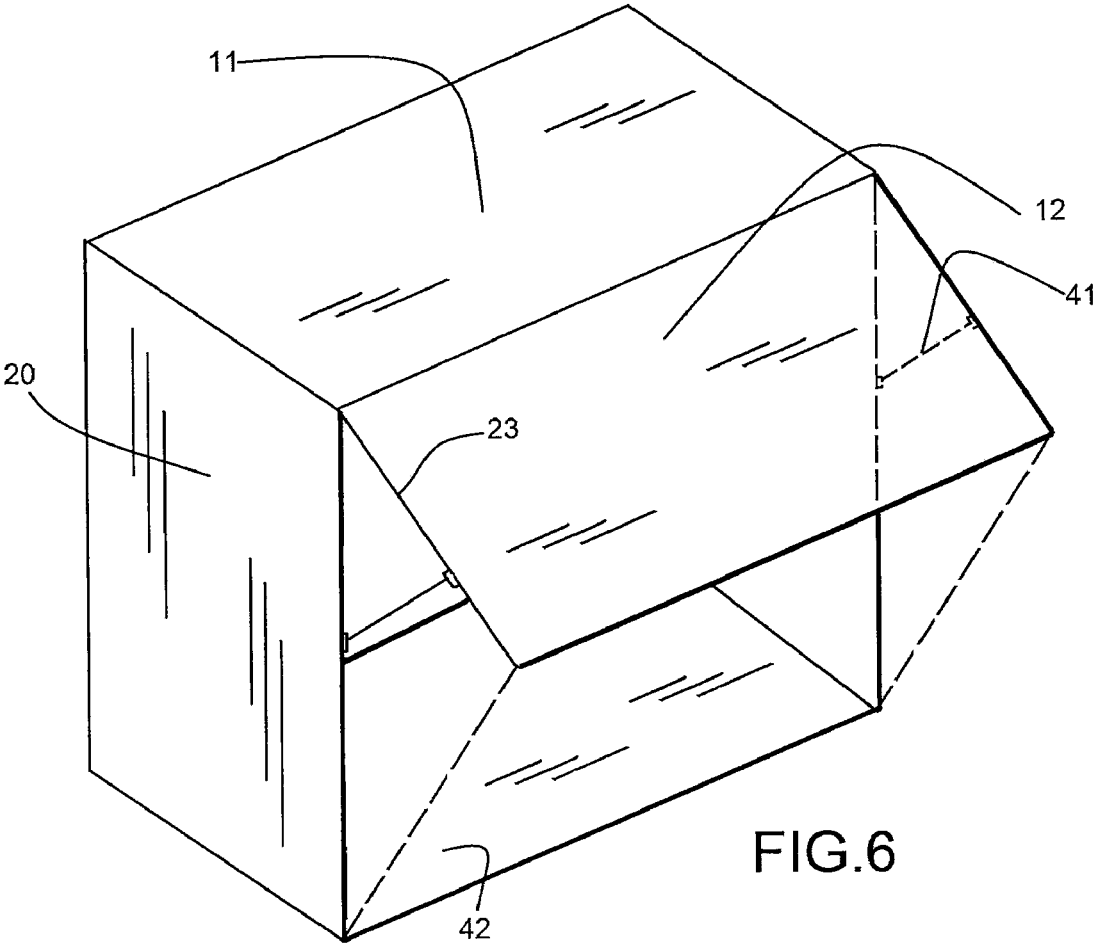

FIG.4





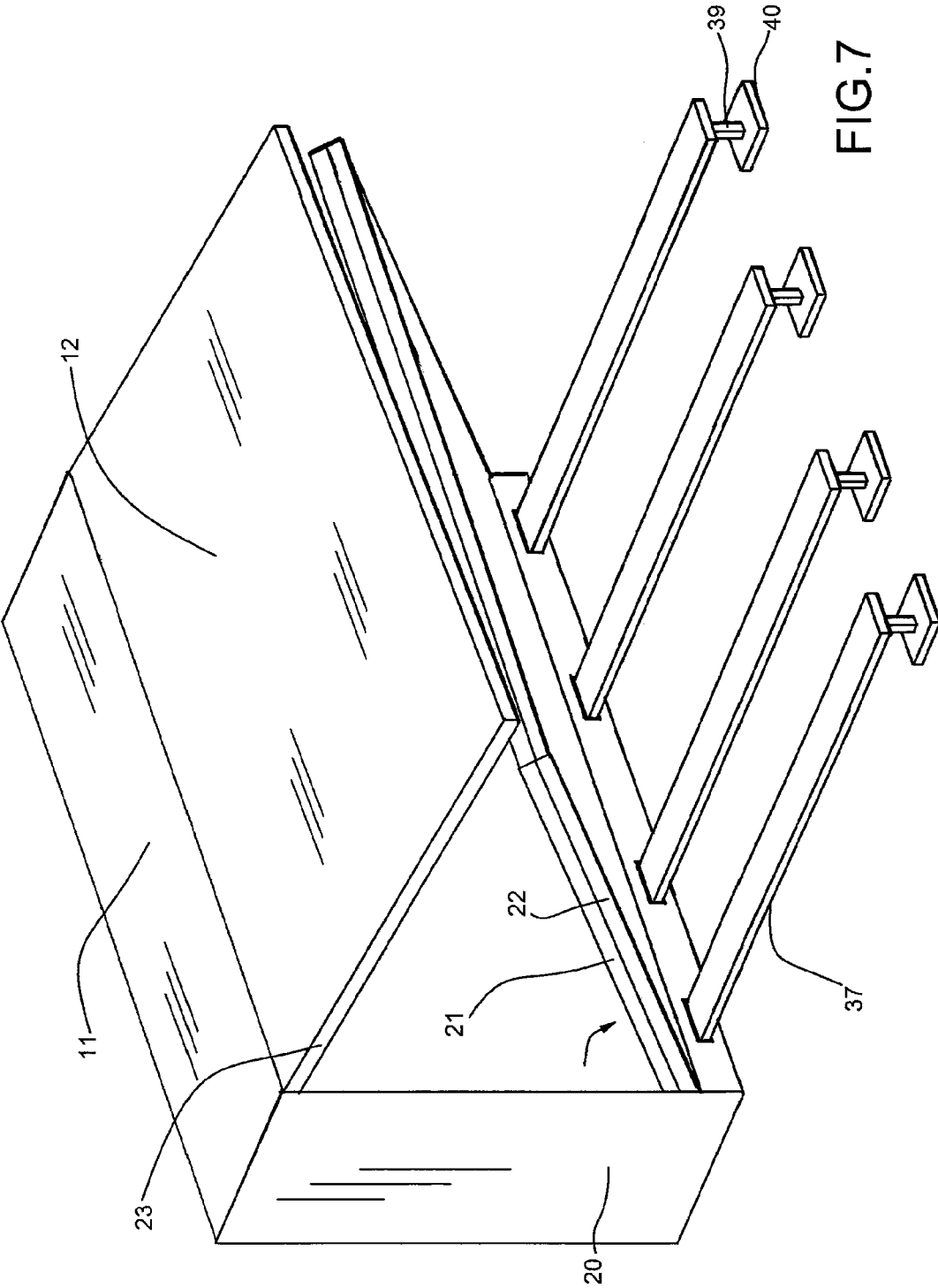

FIG.7



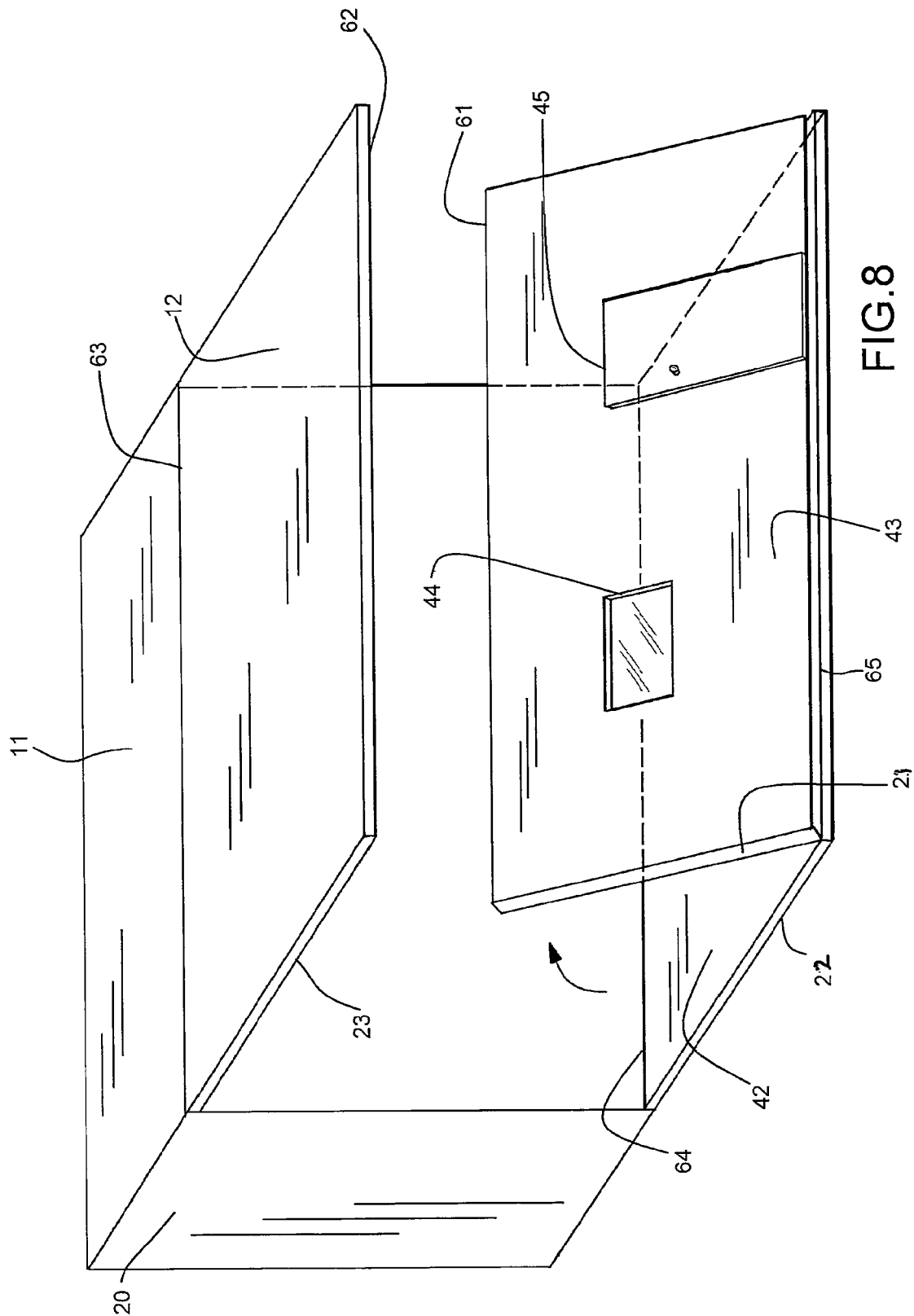

FIG. 8

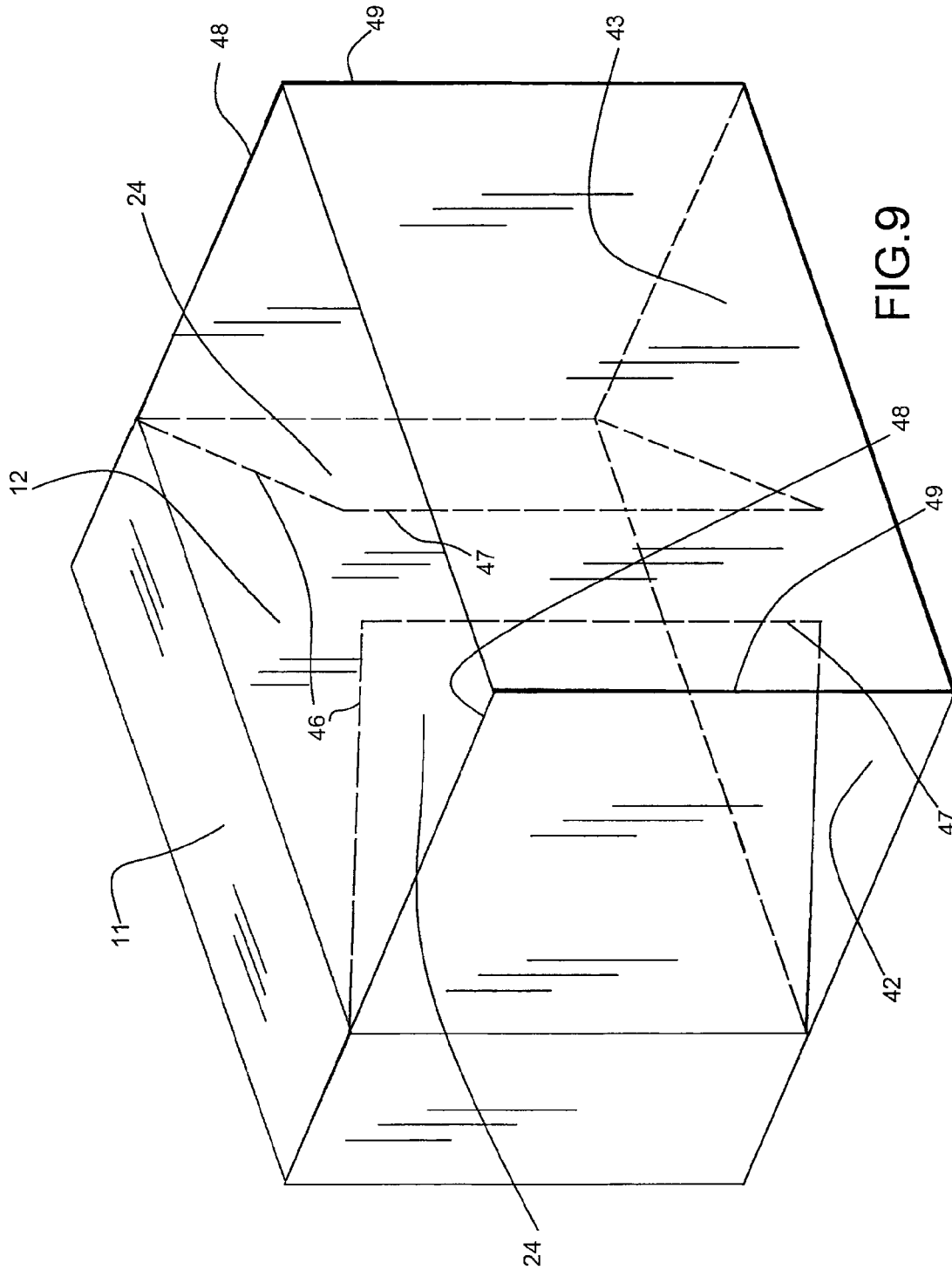

FIG. 9

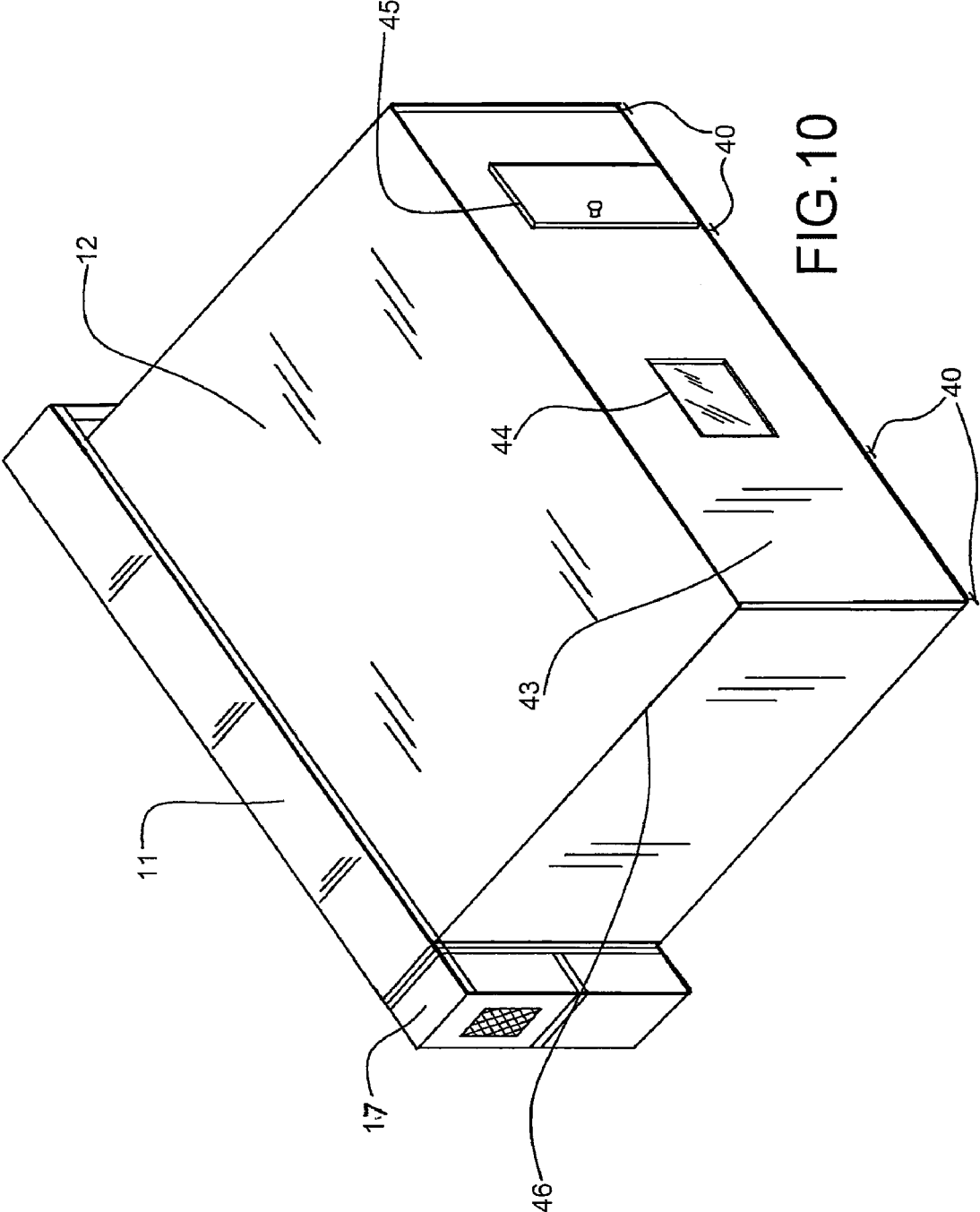

FIG. 10

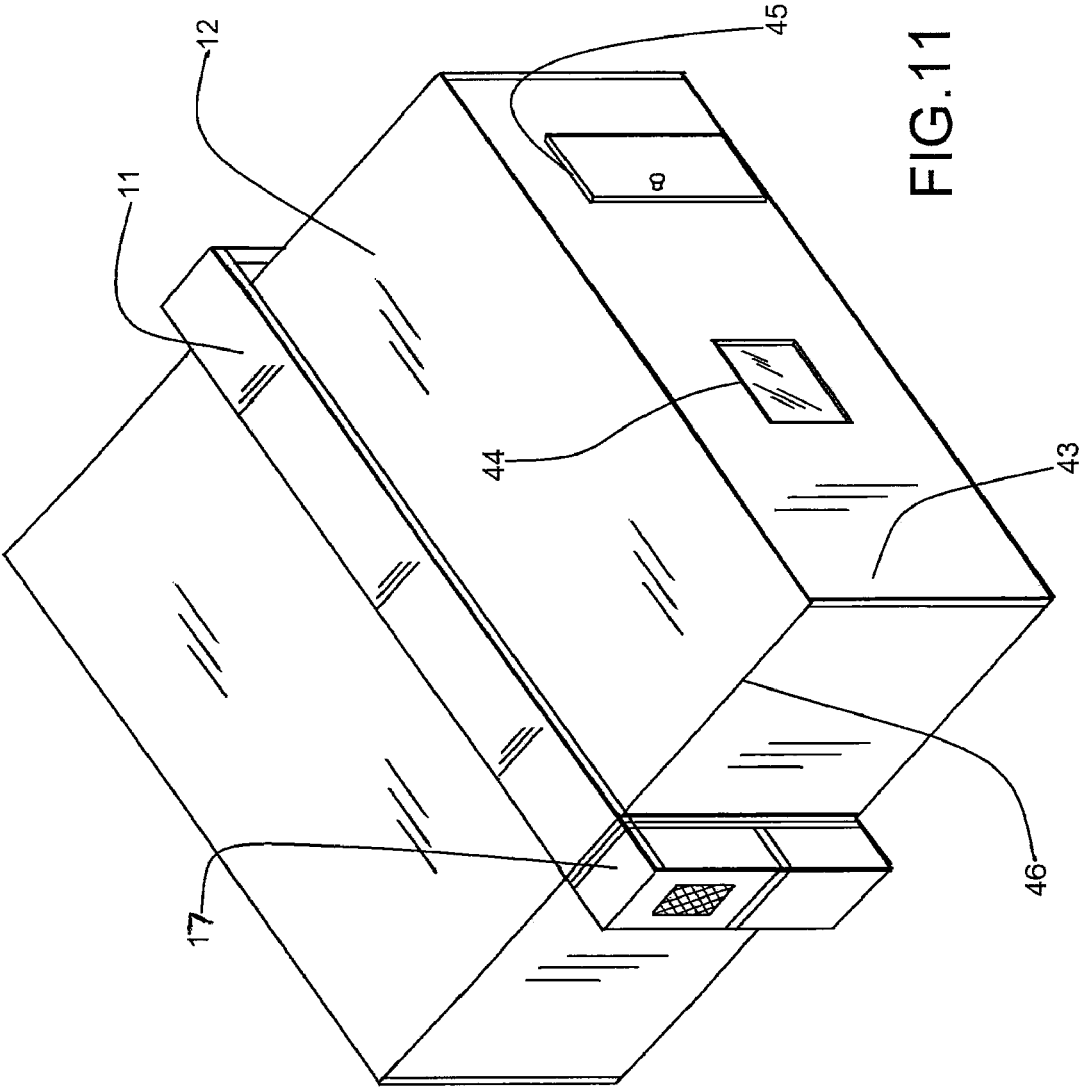

FIG. 11

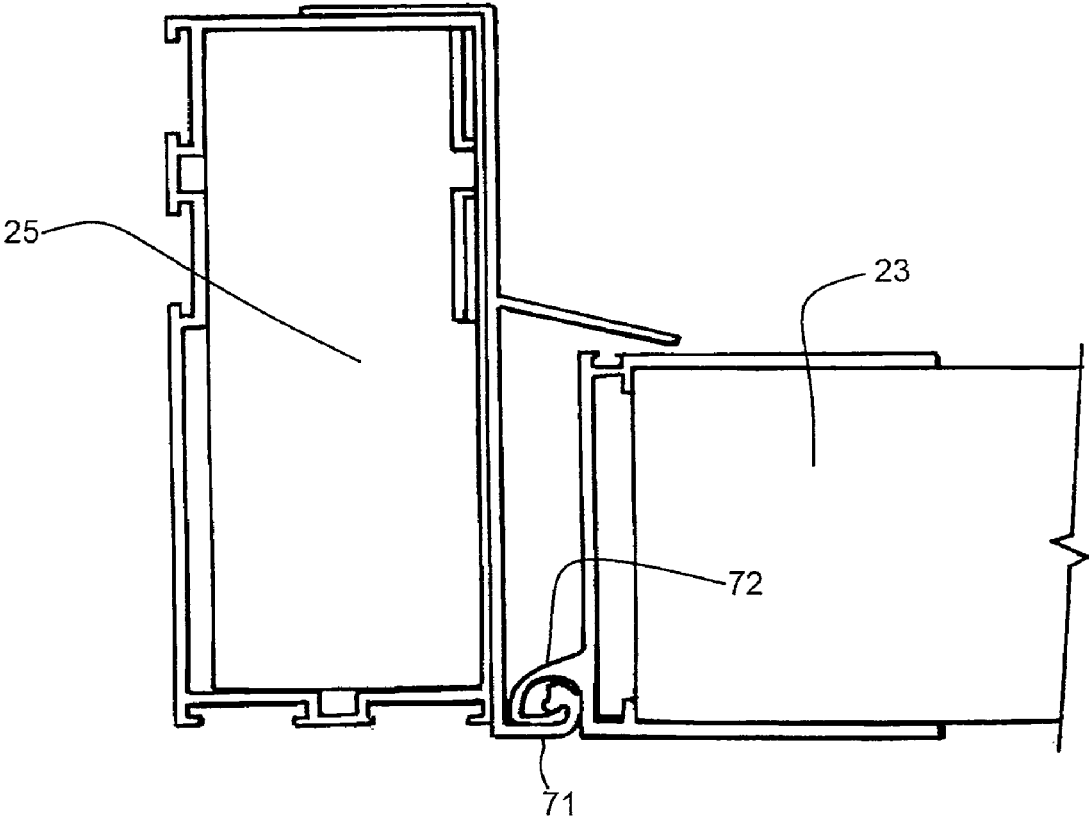

FIG.12a

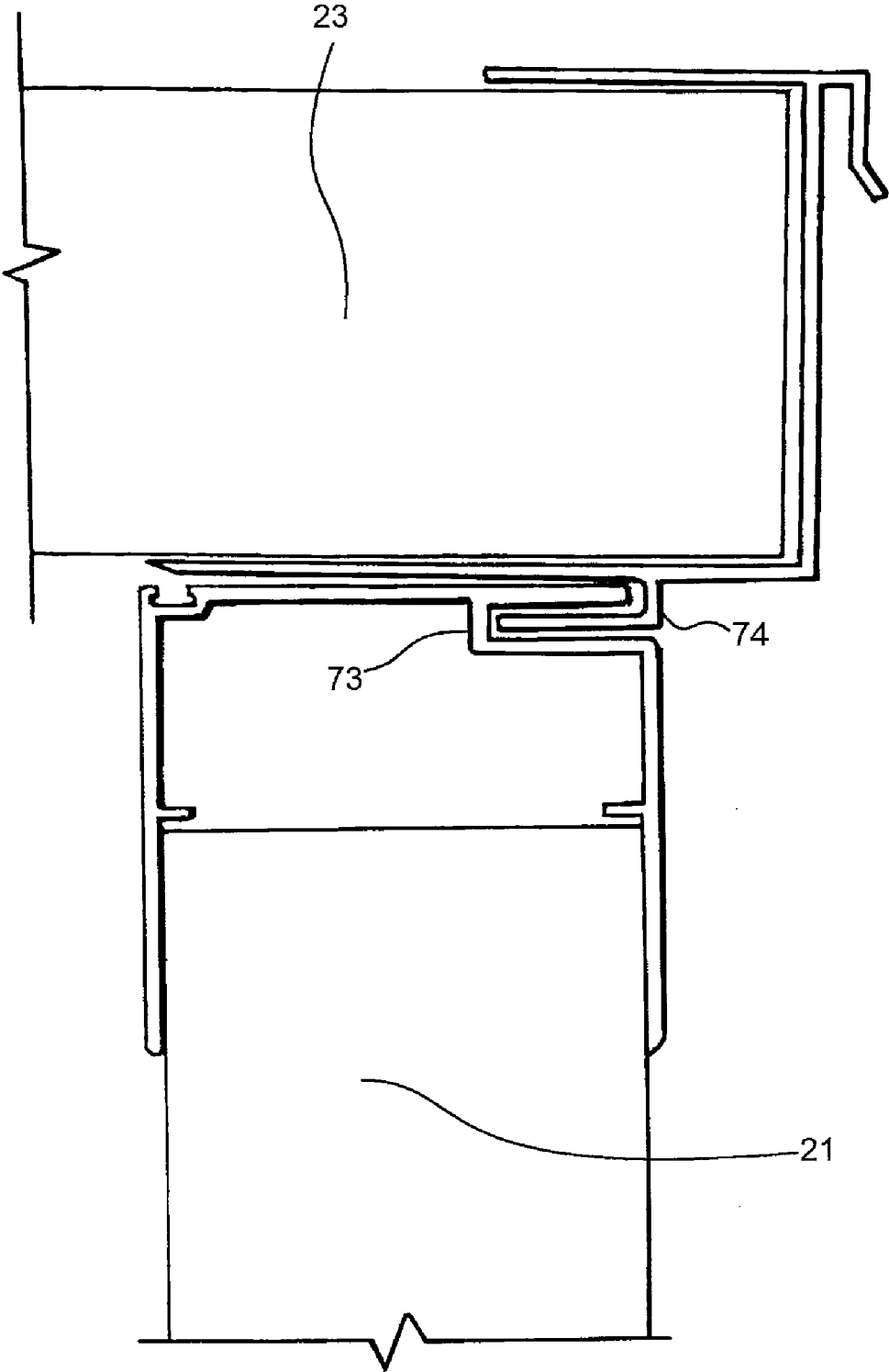

FIG.12b

## COLLAPSIBLE PORTABLE SHELTER UNIT

### RELATED APPLICATIONS

[0001] This application claims priority based upon U.S. Provisional Patent Application Ser. No. 61/510,564 filed Jul. 22, 2011.

### FIELD OF THE INVENTION

[0002] This invention relates to a collapsible portable habitable shelter structure. More particularly, the present invention relates to a structure that collapses into a small, compact configuration that is light, easily stored, easily transported, and can be folded out to become a structurally habitable shelter.

### BACKGROUND OF THE INVENTION

[0003] Emergency type housing units have been desired for numerous applications. Typically the units are nothing more than steel shipping containers which are modified for the usage desired. They tend to be heavy, difficult to transport, provide very limited functional space, and not desirable as a living area. Increasing of the functional space has been crudely addressed by cutting out portions of the container and affixing multiple containers together. The appearance of the units has remained to be that of a shipping container or trailer, usually with the need to perform extensive work on the interior to make the unit functional. Further, a single unit typically does not supply sufficient space to accomplish the needed function as the containers are so narrow in width that two or more containers must be placed together to get a functional space. When multiple units are assembled, the need to prevent water and wind infiltration causes considerable additional work to be done by skilled craftsmen, with specialty products to seal the units and properly connect them, which materials are not always available.

[0004] Since the steel units are bulky, heavy in weight, difficult to store and transport is typically handling one unit at a time, with a crane needed to move the units. These difficulties restrict the usage and desirability of container type units.

[0005] The challenge and need was for a unit that was light weight and compact when not in use so that it may be efficiently stored and transported, that supplies an attractive, functional space, that is strong, water and wind resistant, as well as adaptable to weather conditions, adaptable easily to special needs, and could be installed without special supplies or skilled labor in minimal time periods.

### DISCLOSURE OF THE INVENTION

[0006] The present invention is a transformable collapsible structure or unit with a rigid center core structure with a top portion, a base portion, a first and second end section, affixed to a welded aluminum extrusion frame structure, to which is connected multiple sections, being a first and a second roof section, a first and a second floor section, a first and a second exterior wall section, and multiple side wall sections. The sections fold out to form an enclosed space adjoining the center core structure on side creating a useable and habitable interior space. The structure is unexpectedly strong and resistant to wind and water infiltration by use of metal extrusions caps at all folding joints which are continuous and interlocking, thereby stopping water or wind infiltration. The points of connection between wall sections where a rotating joint is not needed use a metal extrusion with tongue and groove con-

figuration being tight fitting and which provides structural strength and resistance to both water and wind infiltration.

[0007] The structure or unit is stored in a folded configuration and can be put into use by first leveling the closed unit, placing floor support beams, rotating the roof sections upward to allow the floor and wall sections to be rotated downward, resting the floor section on the floor beams, rotating the exterior wall sections vertical and connecting the roof section to the exterior wall section. The side wall sections are then swung out to connect to the roof section and exterior wall sections.

[0008] When the roof section, floor section, exterior wall section and side wall section are rotated into position, the continuous extended metal caps lock the extrusions together providing structural strength and resistance to wind and water infiltration.

[0009] The connections between the wall sections where the sections do not have a rotation joint have a continuous extruded metal cap which is of a tongue and groove type connection, between mating edges providing structural strength and resistance to water and air infiltration.

### BRIEF DESCRIPTION OF THE DRAWINGS

[0010] To further describe and obtain a fuller understanding of the nature and objectives of the invention, the accompanying drawings are provided in which like parts are given reference numerals.

[0011] FIG. 1 is a perspective of the collapsible portable shelter unit in a closed configuration for storage or transport.

[0012] FIG. 2 is a perspective showing the end of a collapsed unit without the end utility sections or cover in place.

[0013] FIG. 3 shows the frame structure of the center core section of the collapsible unit.

[0014] FIG. 4 shows the support and leveling unit at the corners of the center core section.

[0015] FIG. 5 is a perspective of the unit with the floor support beams being put into place.

[0016] FIG. 6 shows the motion of opening of the unit by rotating of the roof section.

[0017] FIG. 7 shows the floor section being rotated into place.

[0018] FIG. 8 shows the exterior wall section being rotated into an upright position.

[0019] FIG. 9 shows the motion of the side walls being rotated outward to interlock with the roof and exterior wall sections.

[0020] FIG. 10 shows a perspective of the unit with one side opened and locked into place.

[0021] FIG. 11 shows a perspective of the unit with both sides opened.

[0022] FIG. 12 a shows a detail of the interconnection for a rotating joint.

[0023] FIG. 12 b shows a detail of the edge interlock.

### DETAILED DESCRIPTION OF THE INVENTION

[0024] Referencing FIG. 1 is a transformable rectangular collapsible portable unit in the collapsed state being one embodiment of the present invention, which forms a modular unit 10 which is approximately 30 inches in width at edge 16 with a length of approximately 18 feet at edge 19, with height approximately 8 feet at edge 14 allowing three units to be

placed side by side in a typical shipping container or tractor trailer. Different dimensions can be used to meet the intended need for the unit.

**[0025]** The modular unit **10** has a rigid central core frame **19**, composed of aluminum extrusions. The frame, FIG. 3, has horizontal **56** and vertical **27** extrusions welded together to form a rectangle and two such rectangles are welded together with cross beam **28** extrusions. The result is a box beam frame that has greater strength than expected. With the attachment of base portion **26**, roof portion **25**, and the end sections **20**, **13**, the core provides support for the roof sections **25**, floor sections **22**, exterior wall sections **21**, and side wall sections **24**; that are adhered to the core and fold out to form an interior space. At the end of the core, FIG. 1, attached is an air conditioning unit **17**, which can provide both cooled or heated air to the interior space. An electrical storage cabinet **18** is also provided for any needed electrical equipment for power distribution. At the other end of the core, in other configurations a storage cabinet can be affixed. In this closed configuration, FIG. 1, the unit **10** can be easily transported by a lift or wheeled with installation of wheels at each corner of the base portion.

**[0026]** FIG. 2 shows the exposed end of the modular unit. The central core end portion **20** is shown and adjacent to it, on each side, are multiple panels which fold out to transform the modular unit into an expanded useable shelter. The most exterior panel **23** is the extending roof sections, followed by the floor sections **22**, and then the exterior wall sections **21**. The inner most section is the side wall sections **24**. The roof **23**, floor **22**, exterior wall **21** and side wall **24** sections can rotate out to locking positions to create an interior space. The roof, floor, exterior wall and side wall sections are composite panels.

**[0027]** The preferred center core section FIG. 3 is a rigid frame of extruded aluminum vertical beams **27** welded together with horizontal extruded aluminum beams **28**, to create a box beam structure which provides high strength but is light in weight. However, the rigid frame can be configured in various shapes known in the art to provide rigid structures.

**[0028]** FIG. 1 shows supports **15** at each of the corners of the modular unit **10**. FIG. 4 shows the configuration of the support **15**, in detail. It consists of a base plate **29** a supporting leg **30**, supporting plates **32** and **31** to hold the core structure with a wrench **34** that can be inserted into the socket **33** to allow ratcheting or cranking of the supporting leg **30** to allow height and leveling adjustment of the modular unit both quickly and easily. Although this is the preferred embodiment numerous other known mechanisms can be used such as a multi-holed support through which a bolt is passed through to set heights at various discrete settings, or plates with threaded rods connected thereto which can be adjusted by rotating the threaded rod to adjust height.

**[0029]** When it is desired to employ the modular unit, the unit **10** is placed in a cleared area. This can be on stabilized ground, or any reinforced base such as gravel, concrete or asphalt, and the unit **10** is leveled using the supports **15**, to set the correct height and all corners are leveled. Support beams **37** are inserted as shown in FIG. 5 in receptacles **36** located along the base portion of the modular unit. At the other end of the beams **37** are plates with welded threaded rods which thread into the end of the beam **37**. The plate **40** is rotated until all the beams **37** are level and thereby perpendicular with the exterior wall surface **12** of the unit **10**.

**[0030]** FIG. 6 shows the modular unit **10** being opened. The exterior roof panel section **23** is rotated out approximately 90 degrees, away from the unit body. Two spring-loaded dampers **41** as shown in FIG. 6 assist in providing support to the roof section **23**. The exterior portion of the top of the core section **11** and the exterior surface **12** of the roof section **23** are preferably covered with a roofing material or other material, depending upon the use of the unit.

**[0031]** FIG. 7 shows the continued opening of the roof section **23** which allows the combined floor **22** and exterior wall **21** sections to be rotated outward to a resting position upon the supporting floor beams **37**. With the floor section **22** put into place the exterior wall section **21** is rotated vertically and the upper edge **61** interlocks with the exterior edge **62** of the roof section **23**. The detail of the interconnection of edges **61** and **62** is seen in FIG. 12b. Additional interlocking can be accomplished with conventional locking mechanisms located along the exterior wall edge. With the roof edge **62** affixed to the exterior wall edge **61**, the side walls **24** can be folded out as shown in FIG. 9, the edges **46** and **47** of which connect with the roof edge **48** and exterior wall edge **49**.

**[0032]** FIG. 10 shows the expanded configuration of one side of the modular unit **10**, and in FIG. 11 the modular unit has been completely opened. The roof, exterior wall and side wall sections are insulated composite panels comprised of an exterior panel, being a lightweight rust free material, a center core of a thermal resistant material, and an interior panel, all adhered together. In the preferred configuration the interior and exterior panels are aluminum with an interior core of expanded polystyrene foam or a polyurethane foam. The use of insulated panels provides temperature stability and the center core section, with the air conditioning/ventilation unit **17** provide both cooling and heating directly into the habitable interior space. The edges of the panels are capped with metal extrusions which provide the connecting functions between panel edges, either a rotating hinged connection as seen at connections **64** between base portion and floor section, or top portion and roof section **63**, or floor and exterior wall section **65** as shown in FIG. 8, or an interlocking between roof section edge **62** and exterior wall section edge **61** as seen in FIG. 8.

**[0033]** FIG. 12a shows typical rotating connection wherein a top portion cross-section **25** and roof section cross-section **23** connected by an extrusion intersection with cross-section of the components. The two metal extrusion caps interlock by rotating about each other in a circular mating of a portion of the extrusion **71** of the roof top cap with a portion of the extrusion **72** of the roof section cap, locking the extrusions together creating a seal between extrusions. The result is a locking of the extrusions and panels to create a structure stronger than expected. Further, the connection stops water and wind infiltration through the joint.

**[0034]** In other configurations, at the tongue and groove connection, a sealant may be placed at the exterior of the connection to prevent water or wind infiltration. Preferably if sealant is used it should be placed after the connection between the sections are made to allow easier removal of the sealant when disassembling the unit.

**[0035]** FIG. 12b shows the interlock connection used between the roof section **25** outer edge **62** and the upper edge **61** of the exterior wall **21**, which may also be used by the side wall section connecting with the exterior wall section or with the roof section edge. This tongue **74** and groove **73** connection interlock is a substantially continuous contact that pro-



vides a structural integrity for the frame of the opened structure that is stronger than expected. Further, the tongue and groove connection prevents water and air infiltration.

**[0036]** In the configuration shown in FIGS. 8, 10 and 11, one or more windows 44 or doors 45 can be provided in the exterior walls section or side walls sections, as well as pre-wiring the walls and interior core for electric, data, and plumbing services. In other configurations, the modular unit may have interior partitions installed at a later time, to be adjusted as the use of the unit requires. Kitchenette modules and bathroom modules can be added to the unit if those functions are desired.

**[0037]** Since the modular unit contains all needed components pre-installed, a minimally trained crew of two men can level and fully expand a modular unit, having it operational in 15 to 30 minutes, depending on the skill and experience of the crew.

**[0038]** In other configurations, the modular units have wheels located at each end of the rigid central core section which allows the units to be conveniently wheeled to and from storage to truck loading dock without special equipment or moved at the desired location prior to opening. While various exemplary aspects and embodiments have been shown or discussed herein, other modifications that may be employed are within the scope of the invention. Accordingly, the present invention is not limited to the configuration shown, and is intended to embrace all such attention modifications or variations that fall within the spirit and scope of the appended claims.

**[0039]** Furthermore, to the extent that the term “includes” is used in either the detailed description or the claims, such term is intended to be inclusive in a manner similar to the term “comprising” as “comprising” is interpreted when employed as a traditional word in a claim.

What is claimed:

1. A transportable collapsible structure having a core, movable roof, floor, exterior wall and side wall sections, which are connected to each other or to the core of the structure by hinges attached to one or more edges of the sections or core which allows the sections to fold out to form an enclosed space adjacent to the core, wherein the improvement comprises combining with the core, roof, floor, exterior wall and side wall sections caps of extruded metal sections which are affixed on the elongated edges of and are the approximate elongated edge length of the core, roof, floor, exterior wall and side wall sections to which they are attached, which is where the sections and/or core are adjoining to each other, wherein the extruded metal caps mate with each other such as to be in continuous contact, allowing rotating motion of the connected sections of approximately ninety degrees between two adjoining sections or core with a section, and when adjoining sections are rotated the two extrusions rotate about each other locking together creating a seal between extrusions.

2. The transportable collapsible structure of claim 1 wherein one or more of the metal extrusions are made from aluminum.

3. The transportable collapsible structure of claim 1 wherein a sealing material is placed between the mating components of the metal extrusions.

4. The transportable collapsible structure of claim 3 wherein one or more of the metal extrusions are made from aluminum.

5. A transportable collapsible structure having a core, movable roof, floor, exterior wall and side wall section, which are connected to each other or to the core of the structure, by hinges attached to one or more edges of the sections or core, which allows the sections to fold out to form an enclosed space adjacent to the core, wherein the improvement comprises combining with the roof, floor, exterior wall and side wall sections caps of extruded metal sections which are affixed on the elongated edges of and are the approximate elongated edge length of the roof, floor, exterior wall and side wall sections to which they are attached, which is where the sections are not rotatably connected to each other, wherein the extruded metal caps mate with each other in a tongue and groove connection.

6. The transportable collapsible structure of claim 5 wherein one or more of the metal extrusions are made from aluminum.

7. The transportable collapsible structure of claim 5 wherein a sealing material is placed between the mating components of the metal extrusions.

8. The transportable collapsible structure of claim 7 wherein one or more of the metal extrusions are made from aluminum.

9. The transportable collapsible structure of claim 1 wherein one or more of the roof, floor, exterior wall or side wall sections are comprised of an inner surface panel, an insulating interior material, and an outer surface panel which are adhered together.

10. The transportable collapsible structure of claim 9 wherein one or more of the surface panels are made from aluminum.

11. The transportable collapsible structure of claim 5 wherein one or more of the roof, floor, exterior wall or side wall sections are comprised of an inner surface panel, an insulating interior material, and an outer surface panel which are adhered together.

12. The transportable collapsible structure of claim 11 wherein one or more of the surface panels are made from aluminum.

13. A transportable collapsible structure, said structure comprising a rigid rectangular core comprising,  
 a base portion,  
 a top portion,  
 a first and a second end section affixed to a rigid welded aluminum extrusion frame structure with the end sections affixed to the opposite ends of the base portion and top portion,  
 a collapsible rectangular container portion integral with the rigid rectangular core comprising,  
 a first and a second roof section,  
 a first and a second floor section,  
 a first and a second exterior wall section,  
 a first and a second side wall section, which are connected to each other or to, the core, which allows the sections to fold out to form an enclosed space adjacent to the core,  
 a plurality of section caps of extruded metal sections which are affixed to the elongated edges of and are the approximate elongated edge length of the roof, floor, exterior wall and side wall sections to which they are attached which is where the sections and/or core are adjoining to each other, wherein the extruded metal caps mate with each other such as to be in continuous contact, allowing rotating motion of the connected sections of approximately ninety degrees between two adjoining sections or

core with a section, when adjoining sections are rotated the two extrusions rotate about each other locking together creating a seal between extrusions,

a plurality of caps of extruded metal sections which are affixed on the elongated edges of and are the approximate elongated edge length of the roof, floor, exterior wall and side sections to which they are attached, which is where the sections are not rotatably connected to each other, wherein the extruded metal caps mate with each other in a tongue and groove connection such as to be in substantially continuous contact and attached together,

a plurality of floor support beams with leveling plate at one end the opposing end fitting into a slot in the base portion of the core, means for leveling the core at each corner of the base portion, wherein the core can be leveled, the floor beams placed and leveled, the roof section being rotated upward to allow the floor section and exterior wall section to be rotated downward such that the floor section rests on the floor beam, the exterior wall section being rotated perpendicular to the floor section such that the outer edge of the exterior wall section connects with the outer edge of the roof section, the side wall section being rotated outward so that the side wall sections connect with the roof and outer wall sections, thereby creating an enclosed useable space.

14. The transportable collapsible structure of claim 13, wherein the metal extrusions are made from aluminum.

15. The transportable collapsible structure of claim 13 wherein the floor, roof, exterior wall and side wall sections are comprised of an interior panel, an exterior panel and an interior insulating material adhered together.

16. The transportable collapsible structure of claim 13, wherein the exterior wall section contains at least one opening.

17. The transportable collapsible structure of claim 13, wherein the side wall section contains at least one opening.

18. The transportable collapsible structure of claim 13, wherein an adjustable support is located at each corner of the base portion.

19. The transportable collapsible structure of claim 18, wherein the adjustable support is adjusted by use of a cranking mechanism.

20. The transportable collapsible structure of claim 13, wherein wheels are attached under the base portion.

21. The transportable collapsible structure of claim 13 wherein the roof sections are assisted in support by spring loaded dampers.

22. The transportable collapsible structure of claim 13 wherein an air conditioning unit supplying cooling or heating is affixed to the core.

23. The transportable collapsible structure of claim 13 wherein an electrical panel unit for supplying electrical current to the interior of the structure is affixed to the core.

\* \* \* \* \*