



US 20080203664A1

(19) **United States**

(12) **Patent Application Publication**
Golad

(10) **Pub. No.: US 2008/0203664 A1**

(43) **Pub. Date: Aug. 28, 2008**

(54) **GAMES' BOARD, ASSEMBLY OF A GAMES' BOARD AND A FIRST NUMBER OF GAME PIECES, AND GAME PIECE**

(52) **U.S. Cl. 273/287; 273/282.1**

(76) **Inventor: Adar Golad, KH Hattem (NL)**

(57) **ABSTRACT**

Correspondence Address:
LADAS & PARRY LLP
26 WEST 61ST STREET
NEW YORK, NY 10023 (US)

Games' board wherein the games' board comprises two identical games' board segments that are detachably attachable to each other. Assembly of a games' board and a first number of game pieces, wherein the games' board has a games' board side on which game pieces can be placed, which games' board side is provided with a second number of at least almost identical games' board recesses divided uniformly into rows and columns, wherein each game piece has a rectangular front surface bearing game marks and a support surface situated opposite the front surface for supporting the game piece on the games' board side, wherein the support surface is provided with at least one game piece protrusion which projects above the support surface and can be placed in a games' board recess. Game piece comprising a rectangular front surface bearing game marks and a support surface situated opposite the front surface, wherein the support surface is provided with at least one game piece protrusion projecting above the support surface.

(21) **Appl. No.: 11/982,724**

(22) **Filed: Nov. 2, 2007**

Related U.S. Application Data

(60) **Provisional application No. 60/856,677, filed on Nov. 3, 2006.**

Publication Classification

(51) **Int. Cl. A63F 3/00 (2006.01)**

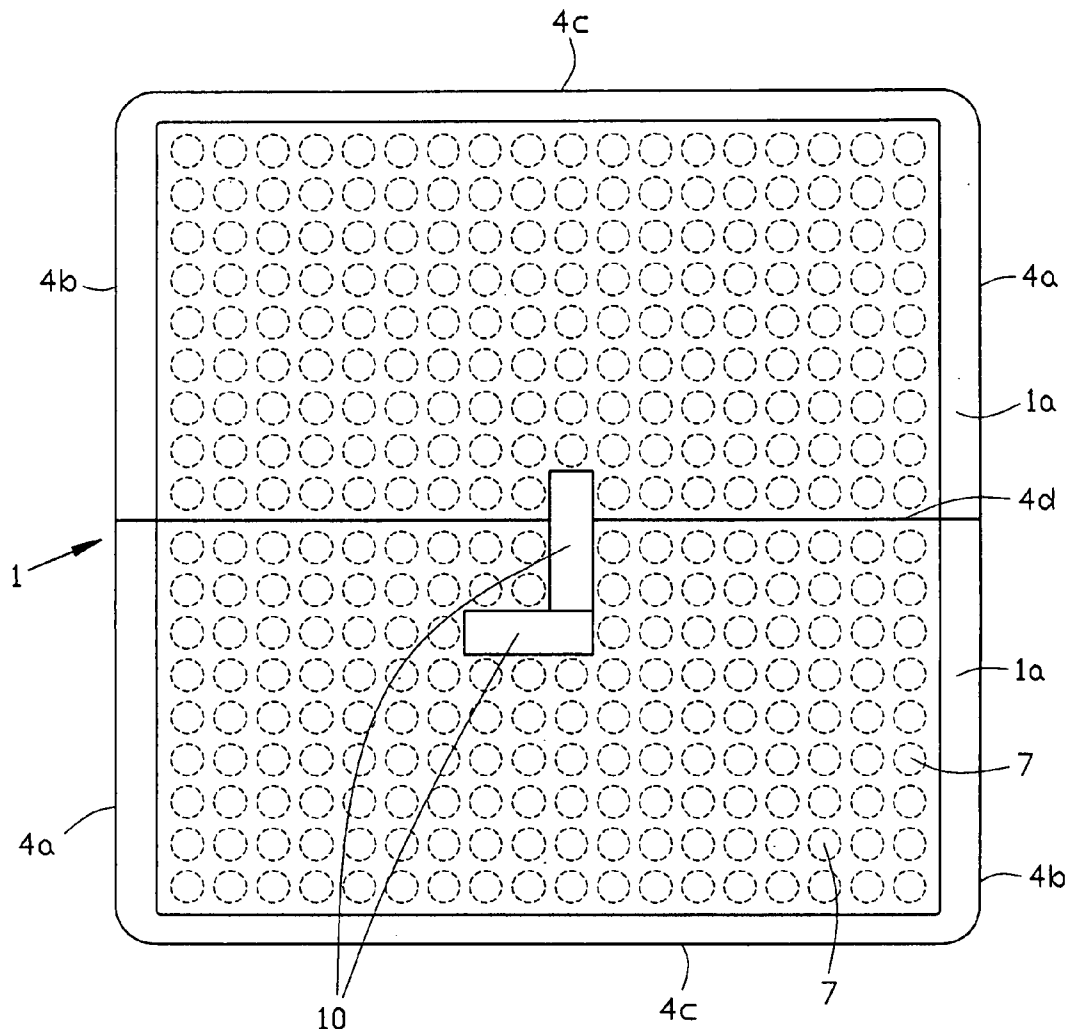

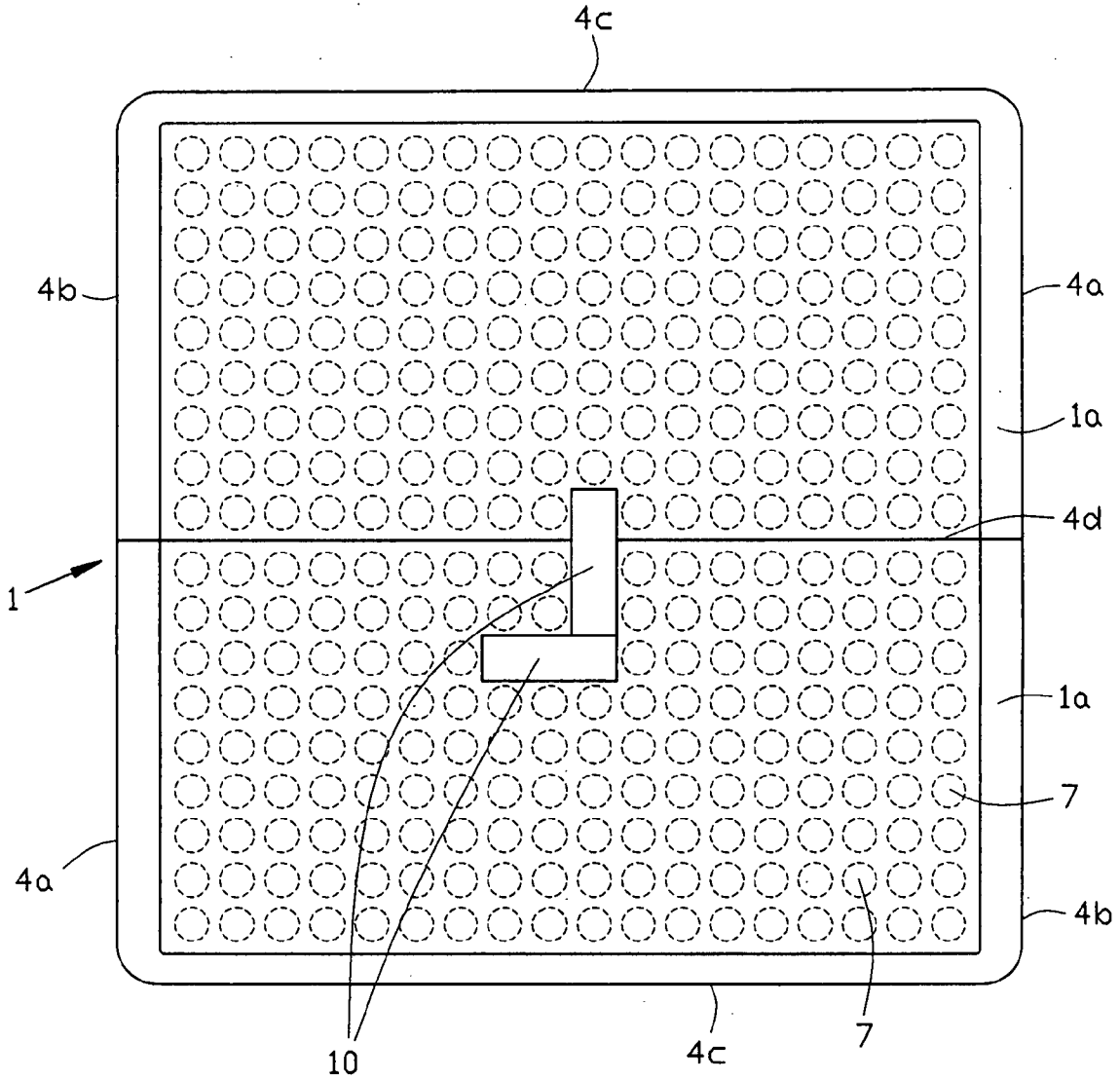

FIG. 1A

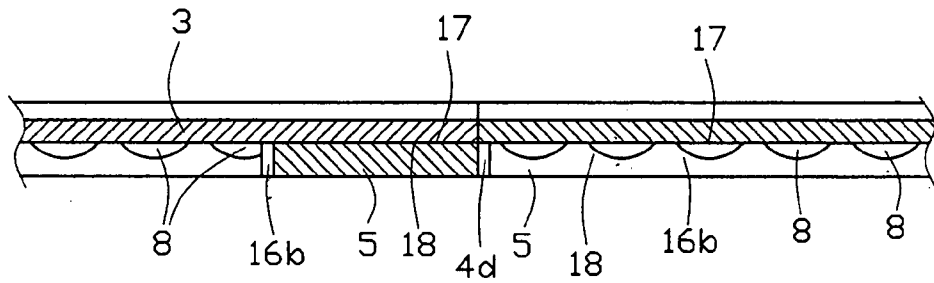

FIG. 1C

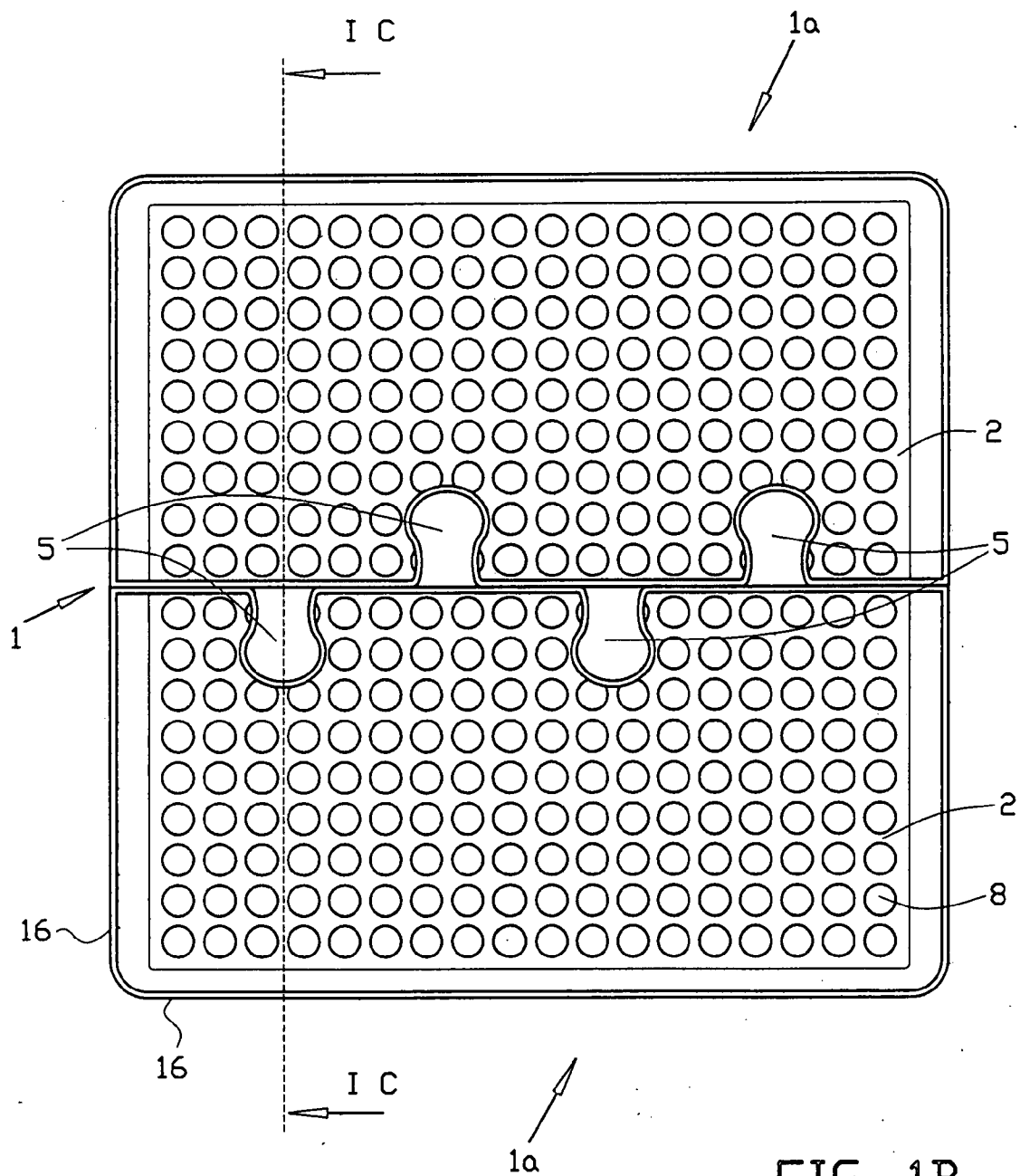

FIG. 1B

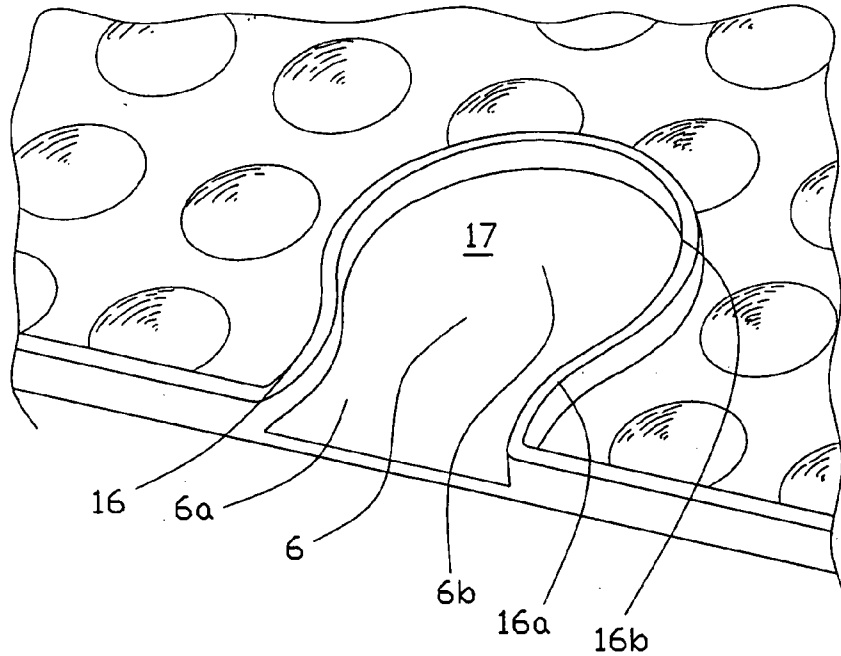

FIG. 2

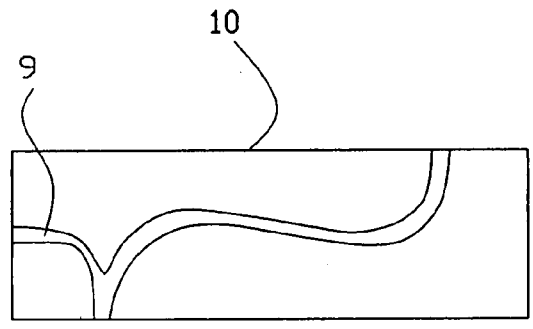

FIG. 3A

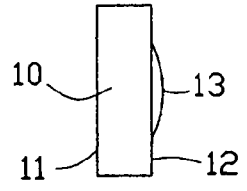

FIG. 3D

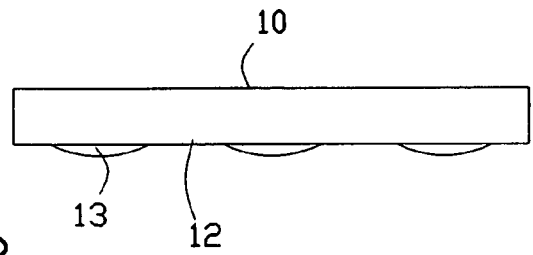

FIG. 3B

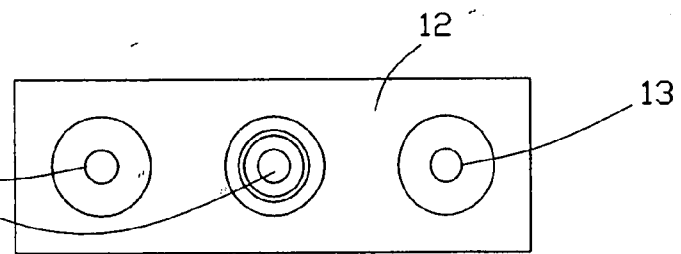

FIG. 3C

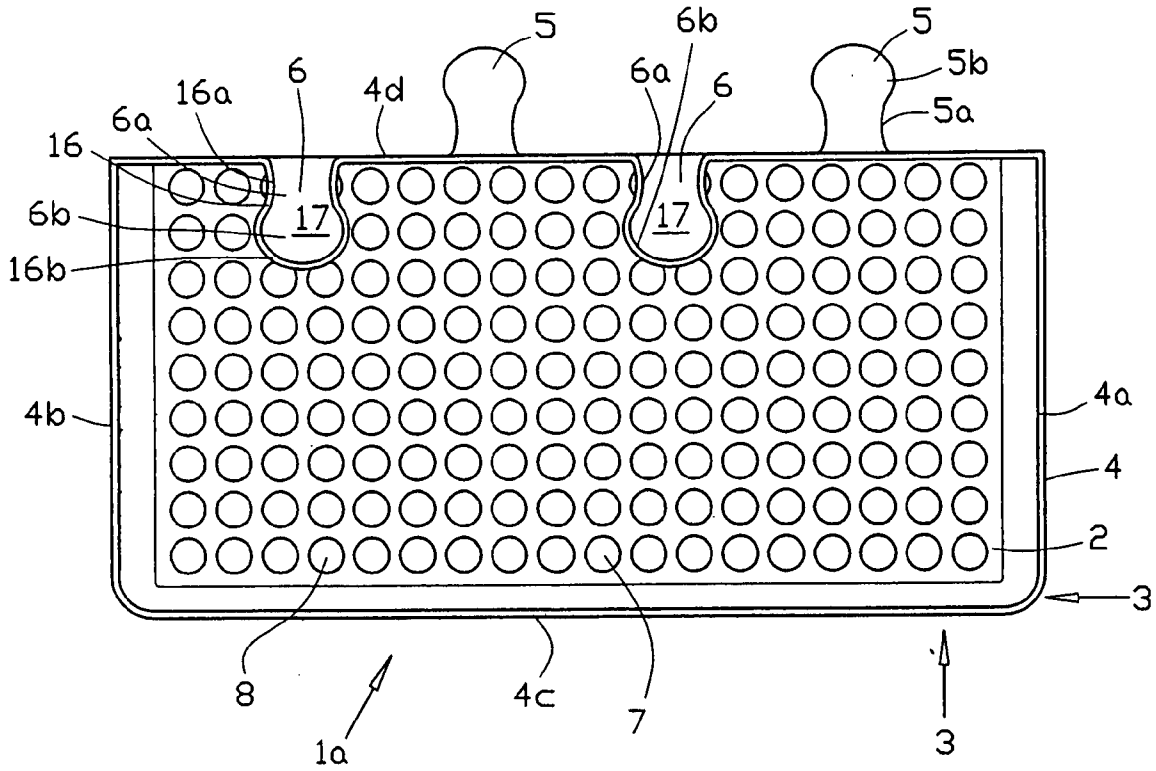

FIG. 4A

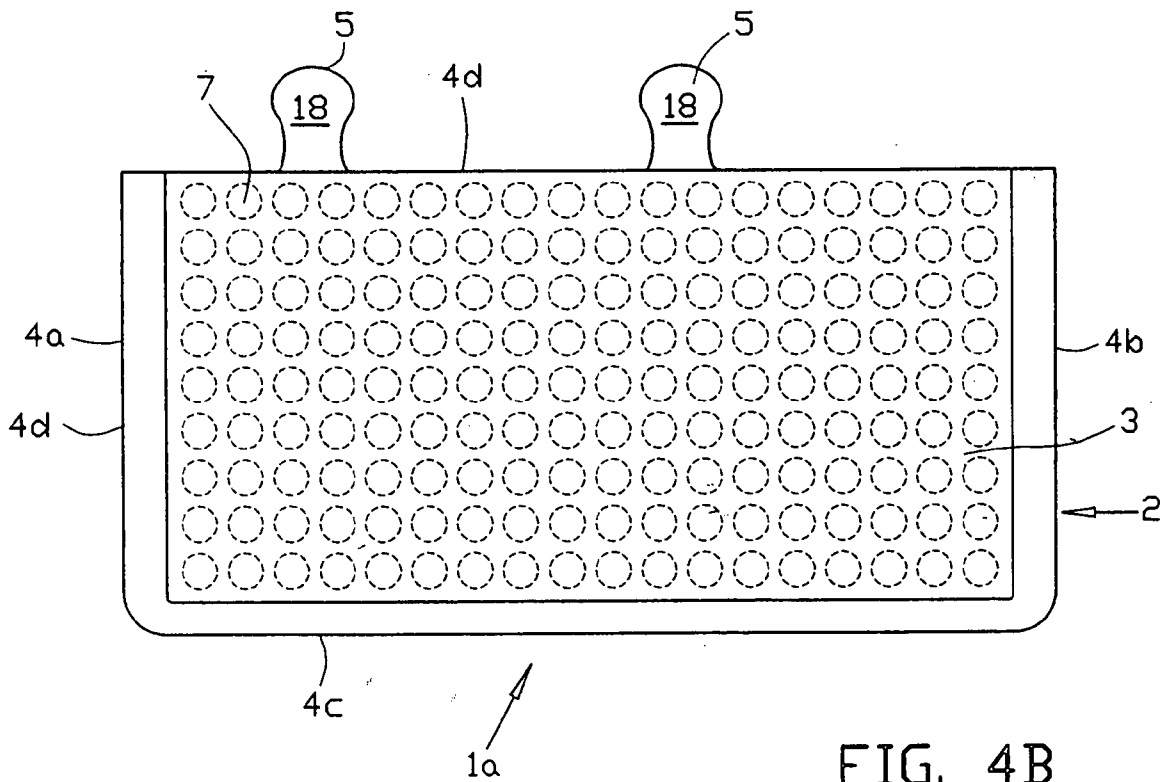

FIG. 4B

GAMES' BOARD, ASSEMBLY OF A GAMES' BOARD AND A FIRST NUMBER OF GAME PIECES, AND GAME PIECE

BACKGROUND OF THE INVENTION

[0001] The present invention relates to a games' board for playing a game thereon.

[0002] Such a games' board is generally known.

[0003] It is among others an object of the present invention to provide a games' board which for reasons of transportation or portability of such a games' board can be reduced to a more compact shape than the one the games' board has when in use.

SUMMARY OF THE INVENTION

[0004] For that purpose the invention provides according to a first aspect a games' board, wherein the games' board comprises two identical games' board segments that are detachably attachable to each other. In the detached condition of the games' board segments, such a games' board takes up little room and is highly suitable to be used as a travel games' board.

[0005] In one embodiment the games' board has a games' board side having a number of games' board recesses divided uniformly into rows and columns.

[0006] A games' board that is particularly simple as regards construction can be achieved when each of the games' board segments has four sides, and wherein one side is provided with an attachment protrusion and an attachment recess, wherein in the condition in which the games' board segments are attached to each other the attachment protrusion of the one games' board segment is situated in the attachment recess of the other games' board segment.

[0007] In a further embodiment of a games' board according to the invention wherein the attachment protrusion of the one games' board segment positively engages into the attachment recess of the other games' board segment, a mutual attachment of the games' board segments is achieved that will not be ended until exerting a force exceeding a certain threshold, namely the one wherein the positive engagement force is overcome. As a result the attachment of the two games' board segments is quite insensitive to bumping and such.

[0008] When each games' board segment comprises two attachment protrusions and two attachment recesses, the attachment of the games' board segments in nearly all cases suffices in order for the games' board to be used as a travel game.

[0009] Extensive research proved that in practice the attachment of the games' board segments can be secured when the attachment protrusion comprises a convex-shaped thickening which is connected to the games' board segment via a stem part.

[0010] In one embodiment of a games' board according to the invention a particularly simple and compact games' board is achieved when the sides of the side of the games' board situated opposite the games' board side are provided with a raised edge, wherein the raised edge also bounds the attachment recess in the inward direction of the games' board segment, wherein the side of the games' board segment is edge free at the location of the recess.

[0011] In certain cases it will be advantageous when the games' board recesses have a round shape, particularly the shape of a convex segment.

[0012] In one embodiment the games' board is made of synthetic material. As a result the games' board is lightweight, and the edges and the games' board recesses and the attachment protrusions and attachment recesses can be made in one moulding process.

[0013] Although the mutual distance between the games' board recesses in a row and in a column may differ, optionally depending on the game to be played with the assembly, it is preferred among others for playing the game of Tayu, that the distance between the games' board recesses in a column equals the distance between the games' board recesses in a row.

[0014] The invention furthermore relates to an assembly of a games' board and a first number of game pieces, wherein the games' board has a games' board side on which game pieces can be placed.

[0015] Such an assembly is generally known, for instance for playing the game of Tayu. A known drawback of such an assembly is that when the game pieces have been placed on the games' board side it is possible that the game pieces can be inadvertently displaced, for instance by bumping against the games' board. Particularly when the assembly is used during travelling for instance by train, boat, car or airplane, there is a risk of inadvertent displacement of the game pieces.

[0016] It is a further object of the present invention to provide an assembly of a games' board and a first number of game pieces wherein the risk of inadvertent displacement of the game pieces by bumping is at least partially reduced.

[0017] For that purpose the present invention according to a second aspect provides an assembly of a games' board and a first number of game pieces, wherein the games' board has a games' board side on which game pieces can be placed, which games' board side is provided with a second number of at least almost identical games' board recesses divided uniformly into rows and columns, wherein each game piece has a rectangular front surface bearing game marks and a support surface situated opposite the front surface for supporting the game piece on the games' board side, wherein the support surface is provided with at least one game piece protrusion which projects above the support surface and can be placed in a games' board recess. Because the game pieces can be placed in the games' board recesses by means of the game piece protrusions, the game pieces are less susceptible to inadvertent displacements as a result of bumping and such.

[0018] In actual practice it turned out that when the support surface is provided with at least two, particularly three, game piece protrusions that can each be placed in a games' board recess concerned, the game pieces in nearly all cases are highly insensitive to inadvertent displacement as a result of bumping.

[0019] Although the game piece protrusions of one single game piece can be placed in any position with respect to each other, it is preferred, particularly in case of elongated rectangular game pieces, that the game piece protrusions are placed one behind the other.

[0020] In case a game piece protrusion comprises a rounded-off, particularly convex-shaped part as free end, it is ensured that in case of a possible slight displacement of the game piece from the games' board recesses, the game piece as a result of the rounded-off shape, particularly the convex shape of the free end, will be able to gradually slide back into the games' board recess due to gravity.

[0021] An even better locking of the game piece in the games' board recess will be achieved when the game piece

protrusion comprises a cylindrical part having the rounded-off, particularly convex-shaped part as free end.

[0022] Particularly when the assembly is used as a travel game it would be advantageous when the assembly could assume a compact shape. In an advantageous embodiment of the assembly according to the invention this is realised because the games' board comprises two identical games' board segments that are detachably attachable to each other.

[0023] An assembly that is particularly simple as regards construction can be achieved when each of the games' board segments has four sides, and wherein one side is provided with an attachment protrusion and an attachment recess, wherein in the condition in which the games' board segments are attached to each other the attachment protrusion of the one games' board segment is situated in the attachment recess of the other games' board segment.

[0024] In a further embodiment of an assembly according to the invention wherein the attachment protrusion of the one games' board segment positively engages into the attachment recess of the other games' board segment, a mutual attachment of the games' board segments is achieved that will not be ended until exerting a force exceeding a certain threshold, namely the one wherein the positive engagement force is overcome. As a result the attachment of the two games' board segments is less sensitive to bumping and such.

[0025] When each games' board segment comprises two attachment protrusions and two attachment recesses, the attachment of the games' board segment in nearly all cases suffices in order for the assembly to be used as a travel game.

[0026] Extensive research proved that in practice the attachment of the games' board segments can be secured when the attachment protrusion comprises a convex-shaped thickening which is connected to the games' board segment via a stem part.

[0027] In one embodiment of an assembly according to the invention a particularly simple and compact games' board is achieved when the sides of the support side of the games' board situated opposite the games' board side are provided with a raised edge, wherein the raised edge also bounds the attachment recess in the inward direction of the games' board segment, wherein the side of the games' board segment is edge free at the location of the recess.

[0028] Particularly in case the free end of the game piece protrusions comprises a rounded-off shape, particularly a convex shape, as free end, it is advantageous when the games' board recesses have a round shape, particularly the shape of a convex segment.

[0029] In one embodiment of an assembly according to the invention the games' board is made of synthetic material. As a result the games' board is lightweight, and the edges, the games' board recesses, the attachment protrusions and attachment recesses can be made in one moulding process.

[0030] In one embodiment of an assembly according to the invention which is particularly suitable for playing the game of Tayu, the front surface of a game piece is provided with a line pattern. In that case it is particularly advantageous when at least a part of the first number of game pieces has a line pattern that differs from the line pattern of another part of the first number of game pieces. It is furthermore advantageous when a first and a second game piece can be chosen from the first number of game pieces, so that when said game pieces are placed adjacent to each other on the games' board side, the line patterns of said game pieces are at least partially continuous.

[0031] Although the mutual distance between the games' board recesses in a row and in a column may differ, optionally depending on the game to be played with the assembly, it is preferred among others for playing the game of Tayu, that the distance between the games' board recesses in a column equals the distance between the games' board recesses in a row. When the support surface of a game piece has at least two game piece protrusions, said distance between games' board recesses preferably equals the distance between the game piece protrusions.

[0032] According to a third aspect, the present invention provides a game piece comprising a rectangular front surface bearing game marks, particularly a line pattern, and a support surface situated opposite the front surface, wherein the support surface is provided with at least one game piece protrusion projecting above the support surface. It has turned out to be advantageous when a game piece is provided with at least two, particularly three game piece protrusions. Especially in case of elongated, rectangular game pieces its is advantageous when the three game piece protrusions are placed one behind the other. In one embodiment of a game piece according to the invention a game piece protrusion comprises a rounded-off, particularly convex-shaped part as free end, wherein preferably the game piece protrusion comprises a cylindrical part having the rounded-off, particularly convex-shaped part as free end.

[0033] The aspects and measures described in this description and the claims of the application and/or shown in the drawings of this application may where possible also be used individually. Said individual aspects, such as an assembly of a games' board and a first number of game pieces and game piece and games' board, and other aspects may be the subject of divisional patent applications relating thereto. This particularly applies to the measures and aspects described per se in the sub claims.

SHORT DESCRIPTION OF THE DRAWINGS

[0034] The invention will be elucidated on the basis of a number of exemplary embodiments shown in the attached drawings, in which:

[0035] FIG. 1A shows a top view of an assembly of a games' board consisting of two identical games' board segments having game pieces according to the invention placed on the games' board side;

[0036] FIG. 1B shows a bottom view of the assembly according to FIG. 1A;

[0037] FIG. 1C shows a side view in cross-section of a part of the assembly shown in FIGS. 1A and 1B;

[0038] FIG. 2 shows a view on an enlarged scale in perspective of a part of a games' board segment showing an attachment recess;

[0039] FIG. 3A shows a top view of the front surface of a game piece according to the present invention;

[0040] FIG. 3B shows a side view of the game piece shown in FIG. 3A;

[0041] FIG. 3C shows a bottom view of the game piece shown in FIGS. 3A and 3B;

[0042] FIG. 3D shows a front view of the game piece shown in FIGS. 3A, 3B and 3C;

[0043] FIG. 4A shows a bottom view of a games' board segment as shown in FIG. 1A showing the attachment protrusions and attachment recesses; and

[0044] FIG. 4B shows a top view of the games' board segment shown in FIG. 4A.

DETAILED DESCRIPTION OF THE DRAWINGS

[0045] FIG. 1A shows a top view of an assembly of a games' board 1 consisting of two identical games' board segments 1a, having two game pieces 10 according to the invention placed on the games' board side 3 (FIG. 4B). It will be clear that the number of game pieces 10 placed on the games' board 1 depends on the progress of the game played on the games' board 1. The overall (first) number of game pieces 10 depends on the game to be played on the games' board.

[0046] The games' board side 3 is oriented towards the players when playing the game, and it is provided with a (second) number of at least almost identical games' board recesses 7 uniformly divided into rows and columns.

[0047] Each game piece 10 has a rectangular front surface 11 bearing game marks (as shown in top view in FIG. 3A) and a support surface 12 situated opposite the front surface (FIGS. 3B, 3C, 3D) for supporting the game piece 10 on the games' board side 3 of the games' board 1.

[0048] According to the invention the support surface 12 is provided with at least one game piece protrusion 13 (FIGS. 3B, 3C, 3D) projecting above the support surface 12, which game piece protrusion can be placed in a games' board recess 7. In FIGS. 3B and 3C the currently most preferred embodiment of the game piece 10 is shown, wherein three game piece protrusions 13 are placed one behind the other in series. However, it will be clear that the invention also applies to any other number of game piece protrusions, and to other mutual positionings of the game piece protrusions, as long as the game piece protrusions can be placed in the games' board recesses. Although the game piece protrusions may have shapes that differ from one another, wherein it is also of importance that the game piece protrusions have to be placeable in the games' board recesses, it is preferred for reasons of production efficiency that the game piece protrusions are at least almost identical to each other. In the currently preferred embodiment, the distance between the games' board recesses 7 in a column equals the distance between the games' board recesses 7 in a row, and said distance equals the distance between the game piece protrusions 13.

[0049] FIG. 3 also shows the currently preferred embodiment of a game piece 10 in which the game piece protrusions 13 comprise a rounded-off, particularly convex-shaped part as free end. In that case the games' board recesses 7 have a matching round shape, particularly the shape of a convex segment, so that the game piece protrusions 13 can be fittingly accommodated in the games' board recesses 7, so that when bumping against the games' board 1 the game pieces 10 will be difficult to displace.

[0050] It will be clear that the game piece protrusions may have another shape than shown in the drawing. For instance in order to prevent inadvertent displacement caused by bumping against the games' board further, it is possible to provide the game piece protrusion with a cylindrical part having the rounded-off, particularly convex-shaped part as free end. The shape of the games' board recesses then has to be adapted accordingly. Optionally the game piece protrusions (or at least one of them) can be provided with friction increasing elements, as schematically shown by the concentric rings of the centre game piece protrusion 13 in FIG. 3C.

[0051] As schematically shown in FIG. 3A, according to a preferred embodiment of the invention, the game marks

arranged on a game piece 10 are formed by a line pattern 9. At least a part of the first number of game pieces has a line pattern that differs from the line pattern of another part of the first number of game pieces.

[0052] When playing the game of Tayu, the intention is that a player starting at one side of the games' board 1, places game pieces adjacent to each other such that a line pattern continuous to the opposite side of the games' board is realised (hindered in the process by the opponent). The assembly according to the invention is particularly suitable for playing this game of Tayu during travelling when the game pieces (and the related line patterns) are made such in advance, that a first and a second game piece can be chosen from the first number of game pieces, so that when said game pieces are placed adjacent to each other on the games' board side, the line patterns of said game pieces are at least partially continuous.

[0053] The games' board 1 shown in FIG. 1A consists of two identical detachably attachable games' board segments 1a. In FIG. 4A and FIG. 4B a bottom view and a top view of one games' board segment 1a are shown respectively. The games' board segment 1a has four sides 4a, 4b, 4c and 4d. In the exemplary embodiment shown, one side 4d is provided with two attachment protrusions 5 and two attachment recesses 6. It will be clear that the present invention is not limited to the shown number of attachment protrusions and attachment recesses, but that each other number can be used within the scope of the invention. In the condition in which the games' board segments 1a are attached to each other, the attachment protrusions 5 of the one games' board segment 1a are sitting in the attachment recesses 6 of the other games' board segment 1a, as shown in the bottom view of FIG. 1B.

[0054] In the currently preferred embodiment the attachment protrusion 5 comprises a convex-shaped thickening 5b which is connected to the games' board segment 1a via a stem part 5a. The attachment recess 6 has a corresponding convex-shaped recess part 6b and a stem-shaped recess part 6a, so that the attachment protrusion 5 fits positively in the attachment recess 6 for improving the mutual attachment of the games' board segments 1a. It will be clear that a positive placement of an attachment protrusion in an attachment recess can be achieved by other shapes of attachment protrusions and attachment recesses.

[0055] The sides 4a, 4b, 4c and 4d of the support side 2 of the games' board 1 situated opposite the games' board side 3 are provided with a raised edge 16 (FIGS. 2 and 4A), wherein the raised edge 16 also bounds the attachment recess 6 in the inward direction (the part of raised edge with reference number 16b in FIG. 2) of the games' board segment, as shown in FIG. 2. This part 16b of the raised edge confines the convex-shaped part of the attachment protrusion, wherein the part 16a of the raised edge confines the stem-shaped part of the attachment protrusions. In order to be able to easily place the attachment protrusion in the attachment recess, the side 4d of the games' board segment 1a is edge free at the location of the recess 6. In FIG. 1C in an assembled games' board, the mutual placement of the attachment protrusion 5 and the attachment recess 6 is shown in more detail in cross-section, wherein all this is dimensioned such that the plane 17 of the attachment recess 6 (also see FIG. 2) abuts the plane 18 of the attachment protrusion (also see FIG. 4B).

[0056] In the currently most preferred embodiment, the games' board 1 is made of synthetic material. In this way the weight of the games' board 1 can be kept low, and the edges

16, the games' board recesses 7, the attachment protrusions 5 and attachment recesses 6 can be made in one moulding process. The games' board recesses at the support side 2 of the games' board 1 can be recognised as round bulges 8 (FIG. 1C).

[0057] The above description is included to illustrate the operation of preferred embodiments of the invention and not to limit the scope of the invention. Starting from the above explanation many variations that fall within the spirit and scope of the present invention, particularly as defined by the attached claims, will be evident to an expert.

1. Games' board (1) wherein the games' board (1) comprises two identical games' board segments (1a) that are detachably attachable to each other.

2. Games' board (1) according to claim 1, wherein the games' board (1) has a games' board side (3) having a number of games' board recesses (7) divided uniformly into rows and columns.

3. Games' board (1) according to claim 1, wherein each of the games' board segments (1a) has four sides (4a, 4b, 4c, 4d), and wherein one side (4d) is provided with an attachment protrusion (5) and an attachment recess (6), wherein in the condition in which the games' board segments (1a) are attached to each other the attachment protrusion (5) of the one games' board segment (1a) is situated in the attachment recess (6) of the other games' board segment (1a).

4. Games' board (1) according to claim 3, wherein at least one of the attachment protrusion (5) of the one games' board segment (1a) positively engages into the attachment recess (6) of the other games' board segment (1a); each games' board segment (1a) comprises two attachment protrusions (5) and two attachment recesses (6); the attachment protrusion (5) comprises a convex-shaped thickening (5b) which is connected to the games' board segment (1a) via a stem part (5a); or the sides (4a, 4b, 4c, 4d) of the support side (2) of the games' board (1) situated opposite the games' board side (3) are provided with a raised edge (16), wherein the raised edge (16b) also bounds the attachment recess (6) in the inward direction of the games' board segment (1a), wherein the side (4d) of the games' board segment (1a) is edge free at the location of the recess (6).

5. (canceled)

6. (canceled)

7. (canceled)

8. Games' board (1) according to claim 1, wherein at least one of games' board recesses (7) have a round shape, particularly the shape of a convex segment; the games' board (1) is made of synthetic material; or distance between the games' board recesses (7) in a column equals distance between the games' board recesses (7) in a row.

9. (canceled)

10. (canceled)

11. Assembly of a games' board (1) and a number of game pieces (10), wherein the games' board (1) has a games' board side (3) on which game pieces (10) can be placed, which games' board side (3) is provided with a second number of at least almost identical games' board recesses (7) divided uniformly into rows and columns, wherein each game piece (10) has a rectangular front surface (11) bearing game marks (9) and a support surface (12) situated opposite the front surface (11) for supporting the game piece (10) on the games' board side (3), wherein the support surface (12) is provided with at

least one game piece protrusion (13) which projects above the support surface (12) and can be placed in a games' board recess (7).

12. Assembly according to claim 11, wherein the support surface (12) is provided with at least two at least almost identical game piece protrusions (13) that can each be placed in a games' board recess (7) concerned.

13. Assembly according to claim 11, wherein the support surface (12) is provided with three at least almost identical game piece protrusions (13).

14. Assembly according to claim 13, wherein the game piece protrusions (13) are placed one behind the other.

15. Assembly according to claim 11, wherein a game piece protrusion (13) comprises a rounded-off, particularly convex-shaped part as free end.

16. Assembly according to claim 15, wherein the game piece protrusion (13) comprises a cylindrical part having the rounded-off, particularly convex-shaped part as free end.

17. Assembly according to claim 11, wherein the games' board (1) comprises two identical games' board segments (1a) that are detachably attachable to each other.

18. Assembly according to claim 17, wherein each of the games' board segments (1a) has four sides (4a, 4b, 4c, 4d), and wherein one side (4d) is provided with an attachment protrusion (5) and an attachment recess (6), wherein in the condition in which the games' board segments (1a) are attached to each other the attachment protrusion (5) of the one games' board segment (1a) is situated in the attachment recess (6) of the other games' board segment (1a).

19. Assembly according to claim 18, wherein at least one of the attachment protrusion (5) of the one games' board segment (1a) positively engages into the attachment recess (6) of the other games' board segment (1a); each games' board segment (1a) comprises two attachment protrusions (5) and two attachment recesses (6); the attachment protrusion (5) comprises a convex-shaped thickening (5b) which is connected to the games' board segment (1a) via a stem part (5a); or the sides (4a, 4b, 4c, 4d) of the support side (2) of the games' board (1) situated opposite the games' board side (3) are provided with a raised edge (16), wherein the raised edge (16b) also bounds the attachment recess (6) in the inward direction of the games' board segment (1a), wherein the side (4d) of the games' board segment (1a) is edge free at the location of the recess (6).

20. (canceled)

21. (canceled)

22. (canceled)

23. Assembly according to claim 15, wherein the games' board recesses (7) have a round shape, particularly the shape of a convex segment.

24. Assembly according to claim 11, wherein the games' board (1) is made of synthetic material.

25. Assembly according to claim 11, wherein the front surface (11) of a game piece (10) is provided with a line pattern (9).

26. Assembly according to claim 25, wherein at least a part of the first number of game pieces (10) has a line pattern (9) that differs from the line pattern (9) of another part of the first number of game pieces (10).

27. Assembly according to claim 26, wherein a first and a second game piece can be chosen from the first number of game pieces (10), so that when said game pieces are placed adjacent to each other on the games' board side (3), the line patterns of said game pieces are at least partially continuous.

28. Assembly according to claim **12**, wherein the distance between the games' board recesses (**7**) in a column equals the distance between the games' board recesses (**7**) in a row.

29. Assembly according to claim **28**, wherein said distance equals the distance between the game piece protrusions (**13**).

30. Game piece (**10**) comprising a rectangular front surface (**11**) bearing game marks (**9**) and a support surface (**12**) situated opposite the front surface (**11**), wherein the support surface (**12**) is provided with at least one game piece protrusion (**13**) projecting above the support surface (**12**); optionally wherein at least one of the support surface (**12**) comprises at least two at least almost identical game piece protrusions (**13**); a game piece (**10**) is provided with three game piece

protrusions (**13**); or the game piece protrusions (**13**) are placed one behind the other.

31. (canceled)

32. (canceled)

33. (canceled)

34. Game piece (**10**) according to claim **30**, wherein a game piece protrusion (**13**) comprises a rounded-off, particularly convex-shaped part as free end.

35. Game piece (**10**) according to claim **34**, wherein the game piece protrusion (**13**) comprises a cylindrical part having the rounded-off, particularly convex-shaped part as free end.

* * * * *