



US 20180283052A1

(19) **United States**

(12) **Patent Application Publication**  
**VAN HELLEMONT**

(10) **Pub. No.: US 2018/0283052 A1**

(43) **Pub. Date: Oct. 4, 2018**

(54) **MAGNETIC CHILD SAFETY LOCK**

(52) **U.S. Cl.**

(71) Applicant: **Kidzlock LLC**, Farmington Hills, MI (US)

CPC ..... *E05B 65/0014* (2013.01); *E05B 65/46* (2013.01); *E05B 47/0038* (2013.01); *E05C 19/16* (2013.01); *E05B 17/0062* (2013.01)

(72) Inventor: **Robert Wilbur VAN HELLEMONT**, Naples, FL (US)

(57) **ABSTRACT**

(21) Appl. No.: **15/476,298**

A locking mechanism, for locking a closure having a closure side edge and a closure bore in the closure side edge relative to a frame having a frame side edge and a frame bore in the frame side edge is disclosed. The locking mechanism may include a locking member, a moveable magnet, and an actuating magnet. The moveable magnet may be attached to the locking member and may be configured to move within one of the closure bore and the frame bore such that the locking member may be moved so as to engage or disengage the other of the closure bore and frame bore. The actuating magnet may be configured to magnetically cooperate with the moveable magnet to move the locking member from a disengaged position into an engaged position and vice versa.

(22) Filed: **Mar. 31, 2017**

**Publication Classification**

(51) **Int. Cl.**

<i>E05B 65/00</i>	(2006.01)
<i>E05B 65/46</i>	(2006.01)
<i>E05B 17/00</i>	(2006.01)
<i>E05C 19/16</i>	(2006.01)
<i>E05B 47/00</i>	(2006.01)

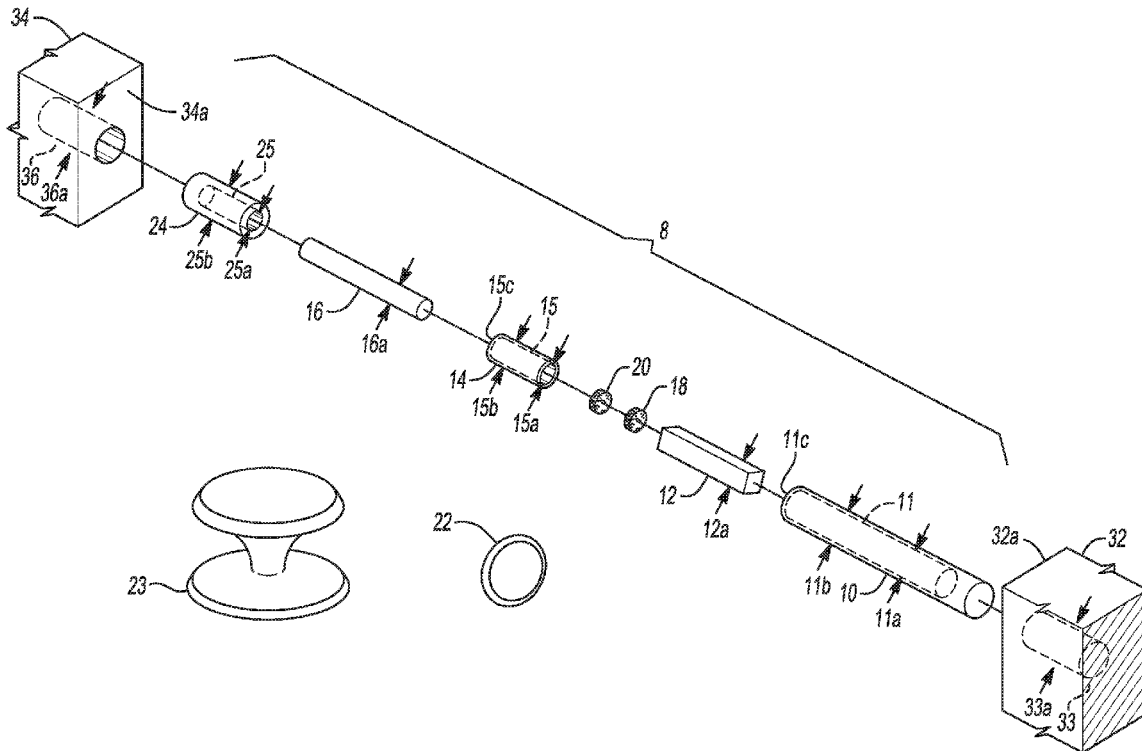

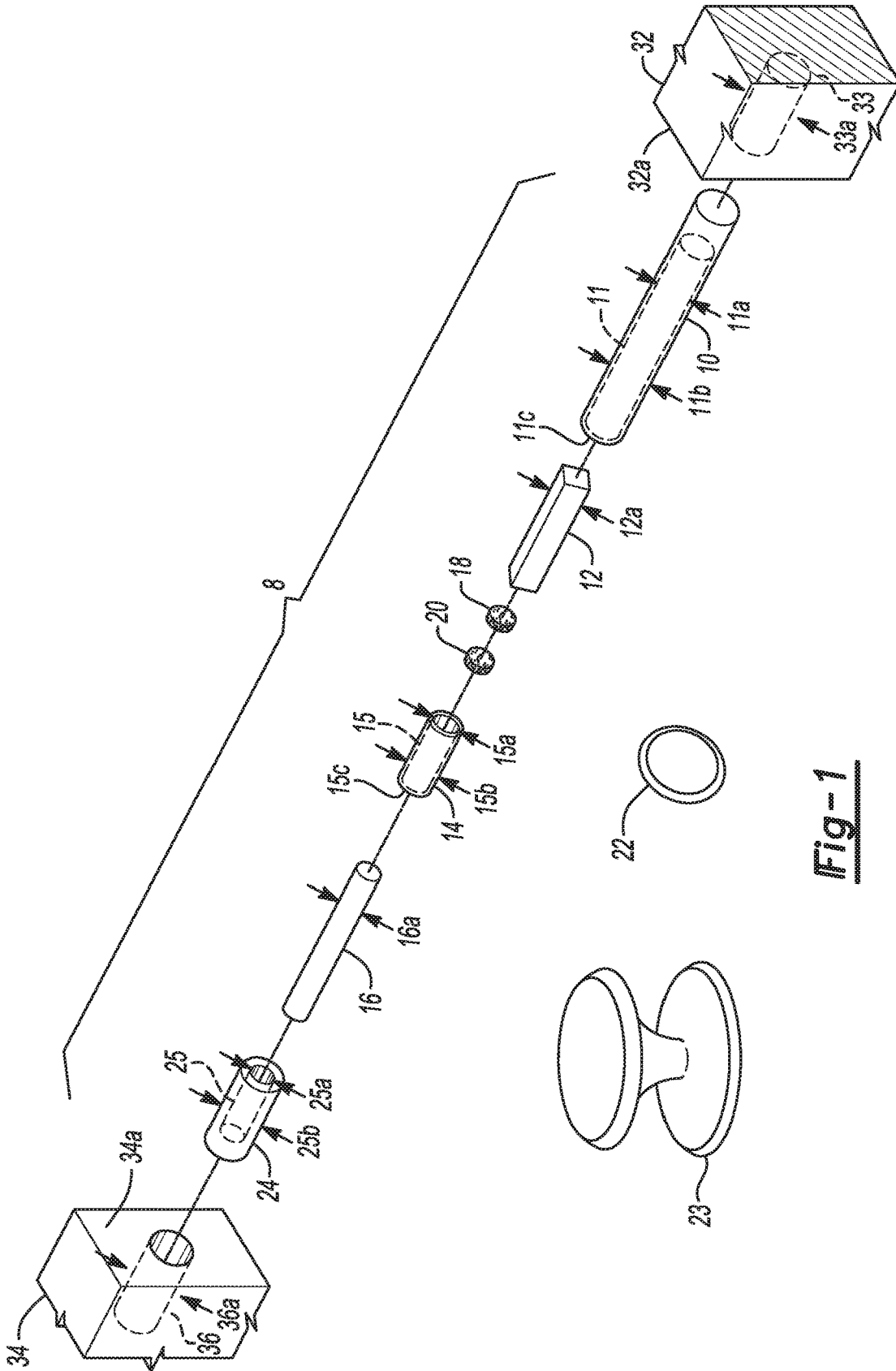

**Fig-1**

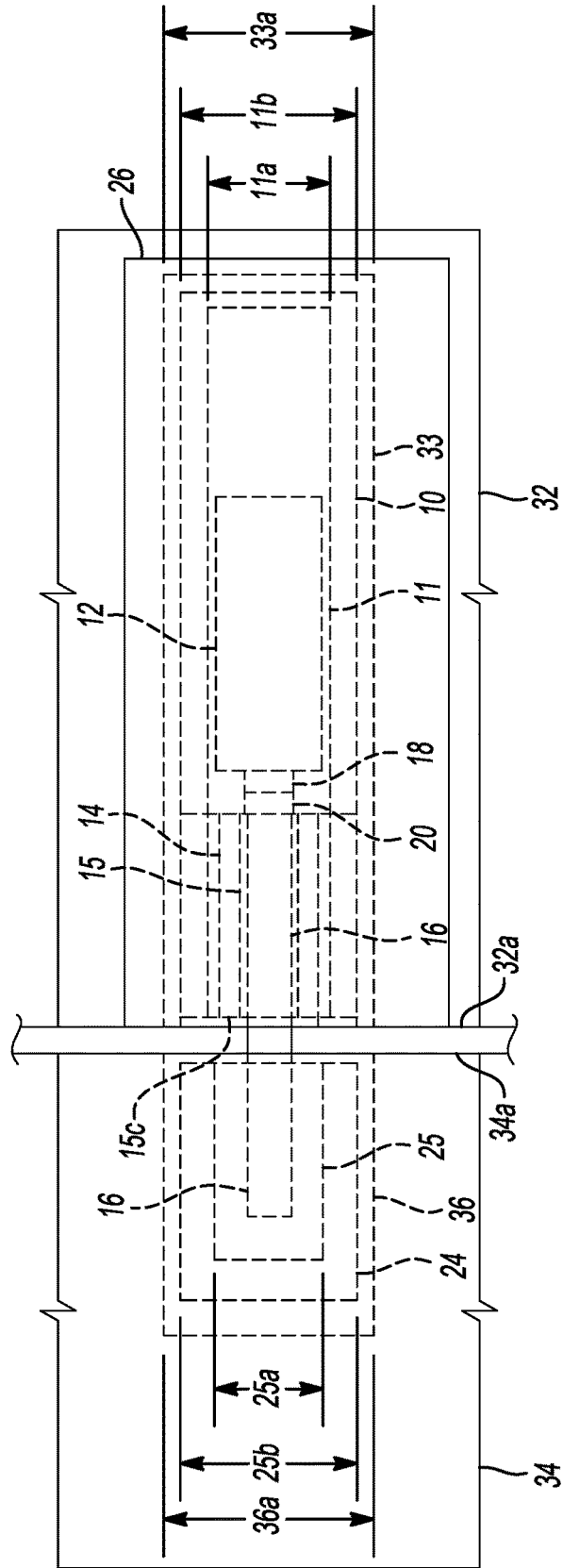

**Fig-2**

## MAGNETIC CHILD SAFETY LOCK

### TECHNICAL FIELD

[0001] The present disclosure relates to child safety locks and more specifically to a magnetic child safety lock that is designed to be retrofitted into existing closures, such as doors and drawers, or manufactured into new closures.

### BACKGROUND

[0002] Unlocked closures, such as entrance, exit, interior, cupboard, or cabinet doors and drawers pose a danger to children that are out of the eyesight of a watchful parent. Even a door or drawer with an ordinary latch or rotatable knob can easily be opened by a child. In such instances, a child could be injured by leaving the home, entering an otherwise secure room, or by opening any such closures and ingesting or handling a harmful household product, medical product, chemical product, or dangerous implement or device stored within such a cupboard, cabinet, drawer, room, or other enclosed area. Parents and guardians are aware of such risks and have tried to mitigate those risks by securing closures, such as doors and drawers, with various locking mechanisms. However, existing methods are often cumbersome, may require modification of the existing latching system, and also may require breaking into the locked closure if the user is unable to unlock the locking mechanism.

### SUMMARY

[0003] According to one embodiment of this disclosure, a locking mechanism, for locking a closure having a closure side edge, and a closure bore in the closure side edge, relative to a frame having a frame side edge, and a frame bore in the frame side edge, is disclosed. The locking mechanism may include a locking member, a moveable magnet, and an actuating magnet. The moveable magnet may be attached to the locking member and may be configured to move within one of the closure bore and the frame bore such that the locking member may be moved so as to engage or disengage the other of the closure bore and frame bore. The actuating magnet may be configured to magnetically cooperate with the moveable magnet to move the locking member from a disengaged position into an engaged position and vice versa.

[0004] According to another embodiment of this disclosure, a locking mechanism, for locking a closure having a closure side edge, and a closure bore in the closure side edge, relative to a frame having a frame side edge, and a frame bore in the frame side edge, is disclosed. The locking mechanism may include a housing sleeve, a locking member, a moveable magnet, and an actuating magnet. The housing sleeve may have a housing sleeve bore and may be disposed within one of the closure bore and the frame bore. The moveable magnet may be attached to the locking member and the moveable magnet and locking member may be configured to move within the housing sleeve bore such that the locking member may be moved so as to engage or disengage the other of the closure bore and frame bore. The actuating magnet may be configured to magnetically cooperate with the moveable magnet to move the locking member from a disengaged position into an engaged position and vice versa.

[0005] According to yet another embodiment of this disclosure, a locking mechanism, for locking a closure having a closure side edge, and a closure bore in the closure side edge, relative to a frame having a frame side edge, and a frame bore in the frame side edge, is disclosed. The locking mechanism may include a housing sleeve, a stop sleeve, a locking member, and a moveable magnet. The housing sleeve may be disposed within one of the closure bore and the frame bore. The stop sleeve may define a stop sleeve bore having a stop sleeve bore diameter or dimension and be disposed axially with the housing sleeve within the one of the closure bore and the frame bore such that the stop sleeve is nearer to other of the closure bore and the frame bore. The moveable magnet may be attached to the locking member and may be configured to move within the housing sleeve bore such that the locking member may be moved so as to engage or disengage the other of the closure bore and frame bore. The moveable magnet may have a moveable outermost magnet diameter or dimension greater than the stop sleeve bore diameter or dimension such that the stop sleeve acts as a stop to prevent the moveable magnet from being moved from the housing sleeve. The actuating magnet may be configured to magnetically cooperate with the moveable magnet to move the locking member from a disengaged position into an engaged position and vice versa.

### BRIEF DESCRIPTION OF THE DRAWINGS

[0006] FIG. 1 is an exploded perspective view of the magnetic lock according to one embodiment.

[0007] FIG. 2 is a plan view of a magnetic lock according to one embodiment installed within a closure, such as a door or drawer.

### DETAILED DESCRIPTION

[0008] As required, embodiments of the present invention are disclosed herein; however, it is to be understood that the disclosed embodiments are merely exemplary of the invention that may be embodied in various and alternative forms. The figures are not necessarily to scale; some features, and the gaps or spaces between some features, may be exaggerated or minimized to show details of particular components. Therefore, specific structural and functional details disclosed herein are not to be interpreted as limiting, but merely as a representative basis for teaching one skilled in the art to employ the present invention in various embodiments.

[0009] A magnetic lock for various household closures, such as doors and drawers, is disclosed herein. The magnetic lock may include an actuation magnet that cooperates with a moveable magnet attached to a locking member. The moveable magnet is magnetically moveable so as to move the locking member from an unlocked position to a locked position and vice-versa. The actuation magnet may be disposed within a structure, such as knob, cabinet pull, or handle, to make it easier to handle and more aesthetically pleasing. The actuation magnet is capable of being removed from magnetic engagement with the moveable magnet such that the actuation magnet can be stored in a different location to prevent a child from attempting to use the actuation magnet to open the closure. In certain embodiments, the locking member may be designed to break when in the locked position if a predetermined force is applied to the closure. Accordingly, if the actuation magnet cannot be located or is no longer capable of unlocking the mechanism,

the closure may still be opened by pushing or pulling on the door or drawer with a predetermined force sufficient to break the locking member. In other embodiments, the locking member may be detachably connected to the moveable magnet via Velcro, any other suitable hook and loop fastener, or similarly detachable fastener. The detachable fastener makes it possible to replace an old, inoperable, or broken locking member with a new locking member.

[0010] Referring to FIG. 1, an exploded view of one embodiment the magnetic child safety lock, and FIG. 2, a plan view of the same embodiment as installed, is illustrated. In accordance with this embodiment, the lock 8 includes a housing sleeve 10 and a stop sleeve 14. Both sleeves 10 and 14 have a tubular configuration such that the housing sleeve 10 defines a housing sleeve bore 11 having a bore diameter or dimension 11a and the stop sleeve 14 defines a stop sleeve bore 15 having a stop sleeve bore diameter or dimension 15a. While the housing sleeve bore 11 could extend through the entire housing sleeve 10, it is preferable that it does not, as shown in FIGS. 1 and 2. The housing sleeve 10 has an outer diameter or dimension 11b while the stop sleeve 14 has an outer diameter or dimension 15b. The stop sleeve outer diameter or dimension 15b is smaller than or approximately equal to the housing sleeve bore diameter or dimension 11a such that the stop sleeve 14 can be inserted into, and preferably fixed, within the housing sleeve bore 11 by any suitable manner, such as via a pressure or friction fit, adhesive, or a fastener. Because of these preferred dimensional relationships, the stop sleeve bore 15 is smaller than the housing sleeve bore diameter or dimension 11a. However, other suitable dimensional relationships could be used. In the embodiment shown, each of the housing sleeve 10, housing sleeve bore 11, stop sleeve 14, and stop sleeve bore 15 has an elongated cylindrical tubular configuration. Elongated means the object has a length that is longer than the width of the object. However, any other suitable configurations or shapes could be used. For example, each could have a shorter non-elongated configuration and each could have a non-cylindrical configuration, such as a configuration having a hexagonal, square, rectangular or other suitable cross-section.

[0011] The housing sleeve 10 and stop sleeve 14 may be made from plastic or any other suitable material. As shown in this embodiment, the housing sleeve 10, together with the inserted stop sleeve 14, are disposed within a closure bore 33 defined within a side edge 32a of closure 32. As used herein, the term "closure" may include any door, such as any exterior, interior, or cabinet door, or any other structure or member that is moveable to allow access to an enclosed area, such as the exterior face of a drawer or a drawer front. The closure bore 33 can be formed, such as by drilling, by a person desiring to utilize a lock 8. While a cylindrically-shaped bore 33 is preferable, and the easiest to form by a user, any suitable closure bore 33 configuration could be used. The closure bore 33 preferably has a closure bore dimension or diameter 33a equal or approximately equal to the housing sleeve outer diameter or dimension 11b such that the housing sleeve 10 may be easily fixed within the closure bore 33 by any suitable manner, such as via a pressure or friction fit, adhesive, or a fastener.

[0012] The housing and stop sleeves 10 and 14 are preferably arranged so that the housing sleeve and stop sleeve bores 11 and 15, although having different diameters, are aligned axially to each other. The housing sleeve 10,

together with the inserted stop sleeve 14, may preferably be disposed such that the housing sleeve end 11c and stop sleeve end 15c nearest the side edge 32a of the closure 32 is very near or aligned with the side edge 32a of the closure 32. However, the housing and stop sleeves 10 and 14 could be disposed in any suitable manner. For example, the housing and stop sleeves 10 and 14 could be disposed such that the ends 11c and 15c nearest the side edge 32a of the closure 32 are not aligned with or very near the side edge 32a of the closure 32 but instead are further within the closure 32. As shown in this embodiment, the housing sleeve 10 is longer than the stop sleeve 14. However, any suitable dimensional relationships could be used that would allow a moveable magnet 12 to move within the housing sleeve bore 11 as described below.

[0013] More specifically, a moveable magnet 12 is disposed within the housing sleeve bore 11 and is preferably attached to a locking member 16 as explained further below. The moveable magnet 12 may be made of a Neodymium magnetic material or any other suitable magnetic material. The moveable magnet 12 has an elongated shape having a moveable magnet outermost diameter or dimension 12a less than the housing sleeve inner diameter or dimension 11a such that the moveable magnet 12 can be moved, such as slidably moved, within the housing sleeve bore 11. The outermost diameter or dimension 12a of the moveable magnet 12 is greater than the stop sleeve bore diameter or dimension 15a of the stop sleeve 14. Because the outermost diameter or dimension 12a of the moveable magnet 12 is larger than the stop sleeve bore diameter or dimension 15a, the stop sleeve 14 prevents the moveable magnet 12 from being overextended and moved out of the housing sleeve bore 11 of the lock 8 after being fully assembled within the closure door 32.

[0014] The moveable magnet 12 is preferably connected in any suitable detachable manner to the locking member 16. For the purposes of this disclosure, connecting the moveable magnet 12 to the locking member 16 in a detachable manner means the two components can be disconnected without permanently damaging either the moveable magnet 12 or locking member 16. Preferably the moveable magnet 12 and locking member 16 may be disconnected by a user applying an axial force on the locking member 16, or to a broken piece of the locking member 16 still connected to the moveable magnet, so as to disconnect the locking member 16, or locking member 16 piece, from the moveable magnet 12. For example, a first detachable fastener member 18 may be disposed on the end of the moveable magnet 12 that is disposed closest to the locking member 16 via a suitable adhesive or in any other suitable manner. The first detachable fastener 18 cooperates with a second detachable fastener member 20 that is disposed on the end of the locking member 16 that is disposed closest to the moveable magnet 12 via a suitable adhesive or in any other suitable manner such that the moveable magnet 12 can be attached in a detachable manner to the striker or locking member 16. The first detachable fastener 18 may be one of a hook or loop Velcro component, or any other suitable hook and loop fabric fastener, or any other suitable detachable fastener. The second detachable fastener 20 may be the other, mating, one of a hook or loop Velcro component, or any other suitable hook and loop fabric fastener, or any other suitable detachable fastener.

[0015] As can be seen in the embodiment shown in FIGS. 1 and 2, the locking member 16 has an outer dimension or diameter 16a and an elongated-cylindrical shape. However, any other suitable configurations or shapes could be used. The locking member outer dimension or diameter 16a is less than the stop sleeve bore inner diameter or dimension 15a such that the locking member 16 can be moved, such as slidably moved, within the stop sleeve bore 15. The locking member 16 may be made from plastic or any other suitable material. However, it is preferable that the locking member 16 be made of a material having a shear or shatter strength such that, as will be explained further, the locking member 16 will break while in the engaged or locked position if a predetermined force, such as a force that could be generated by an “adult” user, is applied in an effort to open the closure 32. It has been determined that a locking member 16 that will break as the result of such a predetermined force ranging from 100 pounds to 150 pounds is suitable, although other ranges could also be suitably employed. As will also be explained further, this will allow an adult user to open the closure 32 in the event the locking member 16 cannot be disengaged from an engaged or locked position, if an actuating magnet 22 cannot be found, or for any other reason. A suitable material for the locking member 16 would include an acrylic plastic or an acrylic glass, such as poly(methyl methacrylate) (PMMA), that shatters when a predetermined force is applied. PMMA may also be known as trade names such as Plexiglas, Acrylite, Lucite, and Perspex among several others. If PMMA is employed, a locking member 16 having a diameter of approximately 8 mm may be suitable.

[0016] As shown in this embodiment, the lock 8 also includes a locking sleeve 24 having an outer diameter or dimension 25b and defining a locking bore 25 having a locking bore diameter or dimension 25a. The locking sleeve 24 may be made from plastic or any other suitable material. In order to use the locking sleeve 24, a frame bore 36 is defined within a frame side edge 34a of a frame 34. As used herein, the term “frame” refers to any suitable member or structure adjacent the closure 32, such as a door frame, door jamb, or a drawer frame. While a cylindrically-shaped frame bore 36 is preferable, and the easiest to form by a user, any suitable frame bore 36 configuration could be used. The frame bore 36 preferably has a frame bore dimension or diameter 36a equal or approximately equal to the locking sleeve outer diameter or dimension 25b of the locking sleeve 24 such that the locking sleeve 24 may be fixed within the frame bore 36 by any suitable manner, such as via a pressure or friction fit, adhesive or a fastener. When the locking sleeve 24 is installed within the frame bore 36, it is preferable that the locking bore 25 is aligned axially with the stop sleeve bore 15 of the stop sleeve 14 as installed in the closure bore 33 of the closure 32.

[0017] The outer locking member outer diameter or dimension 16a is smaller than the locking bore dimension or diameter 25a such that the locking sleeve 24 can receive the locking member 16 within the locking bore 25. As previously mentioned, the outer diameter or dimension 16a of the locking member 16 is preferably smaller than the stop sleeve bore diameter or dimension 15a such that the locking member 16 can be moved, such as slideably moved, within the stop sleeve bore 15 from a retracted to an extended position (and vice-versa). In the retracted position, the locking member 16 is disposed within the stop sleeve bore

15 of the stop sleeve 14 such that the locking member does not extend beyond the closure side edge 32a and the lock 8 is unlocked. In the extended position, the locking member 16 is disposed so as to extend beyond the closure side edge 32a and into the locking bore 25 such that the lock 8 is locked.

[0018] As previously discussed, it is preferable that the locking member 16 be made from a material such that if the locking member 16 is in the extended position, and the lock 8 is locked, the locking member 16 can be broken if a predetermined force, such as a force that could be applied by an adult user, is applied in an effort to open the locked closure 32. In other embodiments, the locking member 16 may include a weakened section or portion that is configured to break if a predetermined force is applied in an effort to open the locked closure 32. For example, the locking member 16 could include a notched or thinner section at a suitable location such that the locking member 16 could be more easily broken at that notched or thinner section. In any event, after the locking member 16 is broken, and because the locking member 16 is preferably detachably connected to the moveable magnet 12, the pieces of the broken locking member 16 can simply be removed from the stop sleeve bore 15 and the locking bore 25. Then, a new locking member 16 having a second detachable fastener member 20 can be inserted into the stop sleeve bore 15 until the second detachable fastener member 20 engages the first detachable fastener member 18 disposed on the end of the moveable magnet 12 such that movement of the moveable magnet 12 will likewise move the new locking member 16.

[0019] An actuating magnet 22 may be moved along or in close proximity to the outer surface of the closure 32 adjacent the moveable magnet 12 to operate the lock 8. The actuating magnet 22 may be made of a Neodymium magnetic material or any other suitable magnetic material. The actuating magnet 22 may have any suitable shape, such as the planar circular shape shown in FIG. 1, and may be mounted to or within a magnet handle or knob 23 having any suitable shape. As the actuating magnet 22 is moved near or adjacently along the length of the housing sleeve 10, the actuating magnet 22 magnetically engages the moveable magnet 12 to extend or retract the locking member 16 into a locked or unlocked position relative to the locking bore 25.

[0020] To assemble and install the lock 8, two holes, the closure bore 33 and the frame bore 36, may preferably be formed, such as by drilling, in the closure 32 and the frame 34 respectively, so as to be axially aligned when the closure 32 is in a closed position relative to the frame 34. While the bores 33 and 36 may be formed within existing or installed closures 32 and frames 34, they may be also be formed by other suitable means before the closures 32 and frames 34 are installed or assembled, such as in a manufacturing facility where prefabricated closures 32, such as cabinet doors, and frames 34, such as cabinet frames, are manufactured. While it is preferable that the bores 33 and 36 are adjacent to and axially aligned with one another when the closure 32 is in a closed position relative to the frame 34, it is also preferable that the locking bore 25 of the locking sleeve 24 is installed within the frame bore 36 be aligned axially with the stop sleeve bore 15 of the stop sleeve 14 as installed in the closure bore 33.

[0021] After forming the bores 33 and 36 in the closure 32 and frame 34 respectively, the housing sleeve 10, together with the moveable magnet 12 (moveably disposed inside the housing sleeve bore 11 such that the first detachable fastener

**18** is oriented toward the closure side edge) and the stop sleeve **14** (inserted into the housing sleeve bore **11** so as to retain the moveable magnet **12**), may be inserted into the closure bore **33**. As discussed, the housing sleeve **10** may be fixed by a press fit or some other suitable means of fastening, including but not limited to using an adhesive, within the closure bore **33**. Before or after such installation, the locking member **16** having a second detachable fastener member **20** can be inserted into the stop sleeve bore **15** until the second detachable fastener member **20** engages the first detachable fastener member **18** disposed on the end of the moveable magnet **12**.

[0022] The locking sleeve **24** may also be fixed within the frame bore **36** by any suitable manner, such as via a pressure or friction fit, adhesive or a fastener. When the locking sleeve **24** is installed within the frame bore **36**, it is preferable that the locking bore **25** is aligned axially with the stop sleeve bore **15** of the stop sleeve **14** as installed in the closure bore **33** of the closure **32** such that the locking member can be moved into engagement or disengagement with the locking bore **25**.

[0023] While the actuating magnet **22** could be used by itself, the actuating magnet **22** may be attached to a magnet handle or knob **23** by any suitable manner, such as via pressure fit, adhesive or a fastener. The actuating magnet **22** may then be used to moveably actuate the moveable magnet **12** to extend and retract the locking member **16**. A protective member **26**, such as a sticker or plate, may be attached to an exterior surface of the closure **32**. The protective member **26** may serve to prevent markings or scratches from occurring as the actuating magnet **22** is moved along the outer surface of the closure **32**. The protective member **26** may also serve as a guide to assist a user in determining where on the outer surface of the closure **32** the actuating magnet **22** should be applied to move the moveable magnet **12** and operate the lock **8**.

[0024] While not shown, in an alternative embodiment, the locking bore **25** having a locking bore diameter or dimension **25a** could be defined by forming such a locking bore **25** in the frame side edge **34** without using a locking sleeve **24**. In such case, the locking bore **25** is preferably aligned axially with the locking member **16** and has a locking bore diameter or dimension **25a** larger than the outer dimension or diameter **16a** of the locking member **16** such that the locking bore **25** can receive the locking member **16** in order to lock the closure **32** as previously described.

[0025] In another alternative embodiment, while sleeves **10** and **14** are shown to be separate pieces, they could be combined as a single sleeve component. In such case, it might be preferable to have the housing sleeve bore **11** extend through the entire length of the housing sleeve **10** such that the moveable magnet **12** can be installed within the housing sleeve bore **11** before such single sleeve component is installed within the closure bore **33**.

[0026] In another alternative embodiment, only one sleeve would be utilized. For example, the housing sleeve **10** need not be installed or utilized. If the housing sleeve **10** is not utilized, the stop sleeve **14** alone would be installed in the closure bore **33**. In such case, the stop sleeve bore **15** having a stop sleeve bore diameter or dimension **15a** would moveably receive the locking member **16** while the moveable magnet **12** would be moveably situated within the closure bore **33** and would have a moveable magnet outermost diameter or dimension **12a** greater than the stop sleeve bore

diameter or dimension **15a** such that the stop sleeve **14** acts as a stop to prevent the moveable magnet **12** from being removed from the closure bore **33**.

[0027] As another example, a housing sleeve **10** alone could be utilized. In such case, the housing sleeve bore **11** having a housing sleeve bore diameter or dimension **11a** would moveably receive both the locking member **16** and the moveable magnet **12**. In such case, there would be nothing to prevent to moveable magnet **12** from being removed from the housing sleeve bore **11**.

[0028] As another example, a stop sleeve **14** having an outer diameter or dimension **15b** greater than the housing sleeve bore diameter or dimension **11a**, such as a stop sleeve outer diameter or dimension **15b** equal to the housing sleeve outer diameter or dimension **11b**, could be used. In such an embodiment, the stop sleeve bore diameter or dimension **15a** would still be smaller than the housing sleeve bore diameter or dimension **11a**, such that the moveable magnet **12** could move within the housing sleeve bore **11** but not into the stop sleeve bore **15**. In such case, the housing and stop sleeves **10** and **14**, with the moveable magnet **12** already within the housing sleeve **14**, would be preferably inserted into and fixed in an end-to-end abutting relationship within the closure bore **33** such that the housing and stop sleeve bores **11** and **15** are axially aligned and such that the stop sleeve **14** is nearest the closure edge **32a** so as to act as a stop and retain the moveable magnet **12** within the housing sleeve bore **11**. Otherwise, such an embodiment would operate in conjunction with the other components as previously described.

[0029] Furthermore, despite the figures showing the locking sleeve **24** installed in the frame bore **36** and the housing sleeve **10** in combination with the stop sleeve **14** installed within the closure bore **33**, the housing sleeve **10** and stop sleeve **14** could alternatively be assembled within an appropriate frame bore **36** and the locking sleeve **24** could alternatively be assembled within an appropriate closure bore **33**.

[0030] While exemplary embodiments are described above, it is not intended that these embodiments describe all possible forms of the invention. Rather, the words used in the specification are words of description rather than limitation, and it is understood that various changes may be made without departing from the spirit and scope of the invention. Additionally, the features of various implementing embodiments may be combined to form further embodiments of the invention.

What is claimed is:

1. A locking mechanism, for locking a closure having a closure side edge and a closure bore in the closure side edge relative to a frame having a frame side edge and a frame bore in the frame side edge, the locking mechanism comprising:
  - a locking member;
  - a moveable magnet attached to the locking member wherein the moveable magnet and locking member are configured to move within one of the closure bore and the frame bore such that the locking member may be moved so as to engage or disengage the other of the closure bore and frame bore; and
  - an actuating magnet configured to magnetically cooperate with the moveable magnet to move the locking member from a disengaged position into an engaged position and vice versa.

2. The locking mechanism of claim 1, wherein the moveable magnet and the locking member are detachably connected to one another such that the moveable magnet may be disconnected from the locking member by a user applying axial force to the locking member without damaging either the moveable magnet or locking member.

3. The locking mechanism of claim 2, wherein the moveable magnet and locking member are detachably connected to one another via a fabric hook and loop fastener.

4. The locking mechanism of claim 1, wherein the locking member is configured to break when in the engaged position if a predetermined force is applied by a user in an effort to open the closure.

5. The locking mechanism of claim 4, wherein the predetermined force has a range between 100 pounds and 150 pounds.

6. The locking mechanism of claim 1, further comprising a stop sleeve disposed within the one of the closure bore and the frame bore in which the moveable magnet and locking member are situated, wherein the stop sleeve defines a stop sleeve bore having a stop sleeve bore diameter or dimension that moveably receives the locking member and the moveable magnet has an moveable outermost magnet diameter or dimension greater than the stop sleeve bore diameter or dimension such that the stop sleeve acts as a stop to prevent the moveable magnet from being removed from the one of the closure bore and frame bore.

7. The locking mechanism of claim 6, further comprising a housing sleeve disposed together with the stop sleeve within one of the closure bore and the frame bore such that the stop sleeve is nearer to one of the closure side edge or frame side edge respectively, wherein the housing sleeve has a housing sleeve bore having a housing sleeve bore diameter or dimension larger than the stop sleeve bore diameter or dimension such that the housing sleeve moveably receives the moveable magnet.

8. The locking mechanism of claim 1, further comprising a locking sleeve disposed within the other one of the closure bore and the frame bore, wherein the locking sleeve defines a locking bore adapted to receive the locking member.

9. The locking mechanism of claim 1, further comprising a housing sleeve disposed within the one of the closure bore and the frame bore in which the moveable magnet and locking member are situated, the housing sleeve defining a housing sleeve bore that moveably receives both the locking member and the moveable magnet.

10. A locking mechanism, for locking a closure having a closure side edge and a closure bore in the closure side edge relative to a frame having a frame side edge and a frame bore in the frame side edge, the locking mechanism comprising:

a housing sleeve having a housing sleeve bore disposed within one of the closure bore and the frame bore;

a locking member;

a moveable magnet connected to the locking member wherein the moveable magnet and locking member are configured to move within the housing sleeve bore such that the locking member may be moved so as to engage or disengage the other of the closure bore and frame bore; and

an actuating magnet configured to magnetically cooperate with the moveable magnet to move the locking member from a disengaged position into an engaged position and vice versa.

11. The locking mechanism of claim 10, wherein the moveable magnet and the locking member are detachably connected by a fabric hook and loop fastener, such that the moveable magnet may be disconnected from the locking member by a user applying axial force to the locking member without damaging either the moveable magnet or locking member.

12. The locking mechanism claim 10, further comprising a stop sleeve disposed axially within the housing sleeve bore, wherein the stop sleeve defines a stop sleeve bore having a stop sleeve bore diameter or dimension that moveably receives the locking member while the moveable magnet has an moveable outermost magnet diameter or dimension greater than the stop sleeve bore diameter or dimension such that the stop sleeve acts as a stop to prevent the moveable magnet from being moved from the housing sleeve.

13. The locking mechanism of claim 10, wherein the locking member is configured to break when in the engaged position if a predetermined force is applied by a user in an effort to open the closure.

14. The locking mechanism of claim 13, wherein the predetermined force has a range between 100 pounds and 150 pounds.

15. The locking mechanism of claim 10, further comprising a locking sleeve disposed within the other one of the closure bore and the frame bore, wherein the locking sleeve defines a locking bore adapted to receive the locking member.

16. A locking mechanism, for locking a closure having a closure side edge and a closure bore in the closure side edge relative to a frame having a frame side edge and a frame bore in the frame side edge, the locking mechanism comprising:

a housing sleeve having a housing sleeve bore;

stop sleeve defining a stop sleeve bore having a stop sleeve bore diameter or dimension, the stop sleeve being disposed axially within the housing sleeve, the stop sleeve and housing sleeve being together disposed within the one of the closure bore and the frame bore such that the stop sleeve is nearer to other of the closure bore and the frame bore;

a moveable magnet configured to move within the housing sleeve bore

a locking member configured to move within the housing sleeve bore and the stop sleeve bore, the locking member attached to the moveable magnet such that movement of the moveable magnet will cause the locking member to move so as to engage or disengage the other of the closure bore and frame bore, and wherein the moveable magnet has an moveable outermost magnet diameter or dimension greater than the stop sleeve bore diameter or dimension such that the stop sleeve acts as a stop to prevent the moveable magnet from being moved from the housing sleeve; and

an actuating magnet configured to magnetically cooperate with the moveable magnet to move the locking member from a disengaged position into an engaged position and vice versa.

17. The locking mechanism of claim 16, wherein the moveable magnet and the locking member are detachably connected by a fabric hook and loop fastener, such that the moveable magnet may be disconnected from the locking



member by a user applying axial force to the locking member without damaging either the moveable magnet or locking member.

**18.** The locking mechanism of claim **16**, wherein the locking member is configured to break when in the engaged position if a predetermined force is applied by a user in an effort to open the closure.

**19.** The locking mechanism of claim **18**, wherein the predetermined force has a range between 100 pounds and 150 pounds.

**20.** The locking mechanism of claim **16**, further comprising a locking sleeve disposed within the other one of the closure bore and the frame bore, wherein the locking sleeve defines a locking bore adapted to receive the locking member.

\* \* \* \* \*