



US 20230323746A1

(19) **United States**
(12) **Patent Application Publication**
Robicheaux et al.

(10) **Pub. No.: US 2023/0323746 A1**
(43) **Pub. Date: Oct. 12, 2023**

(54) **METHOD AND APPARATUS FOR SETTING DOWNHOLE PLUGS AND OTHER OBJECTS IN WELLBORES**

14, 2019.

Publication Classification

(71) Applicant: **Fortress Downhole Tools, L.L.C.**,
Broussard, LA (US)
(72) Inventors: **Michael R. Robicheaux**, Breaux Bridge,
LA (US); **Trey Falgout**, Lafayette, LA
(US); **M. Joseph Montgomery**,
Lafayette, LA (US); **Tyler Cook**,
Youngsville, LA (US)

(51) **Int. Cl.**
E21B 33/12 (2006.01)
E21B 23/04 (2006.01)
(52) **U.S. Cl.**
CPC *E21B 23/042* (2020.05); *E21B 23/0414*
(2020.05); *E21B 33/12* (2013.01)

(21) Appl. No.: **18/318,320**

(57) **ABSTRACT**

(22) Filed: **May 16, 2023**

Related U.S. Application Data

(63) Continuation of application No. 17/699,891, filed on Mar. 21, 2022, now Pat. No. 11,674,361, which is a continuation-in-part of application No. 15/930,928, filed on May 13, 2020, now Pat. No. 11,280,143.

(60) Provisional application No. 62/847,639, filed on May

A wireline conveyed, gas driven setting tool configured to set downhole tools including, without limitation, frac plugs, bridge plugs, cement retainers and packers. The setting tool is functioned by selectively igniting a power charge inside of a firing head. As the power charge burns, it generates gas that acts upon a piston area to stroke the setting tool. A dampening media, as well an optimized flow area at or near the distal end of the setting tool, act to slow the setting stroke.

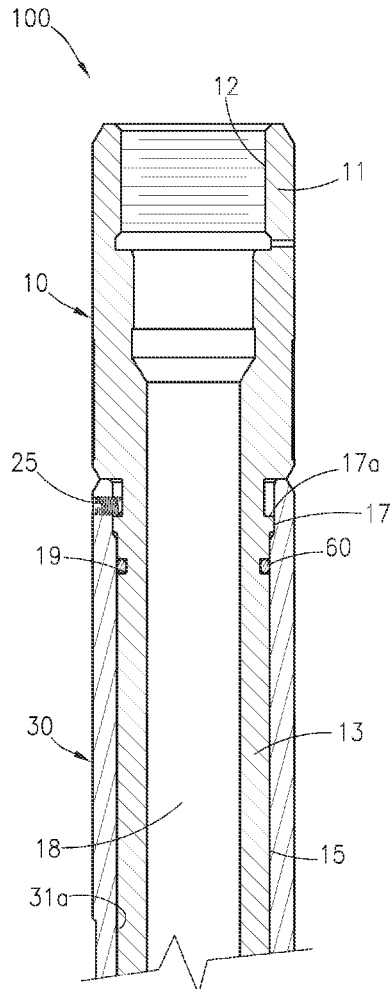

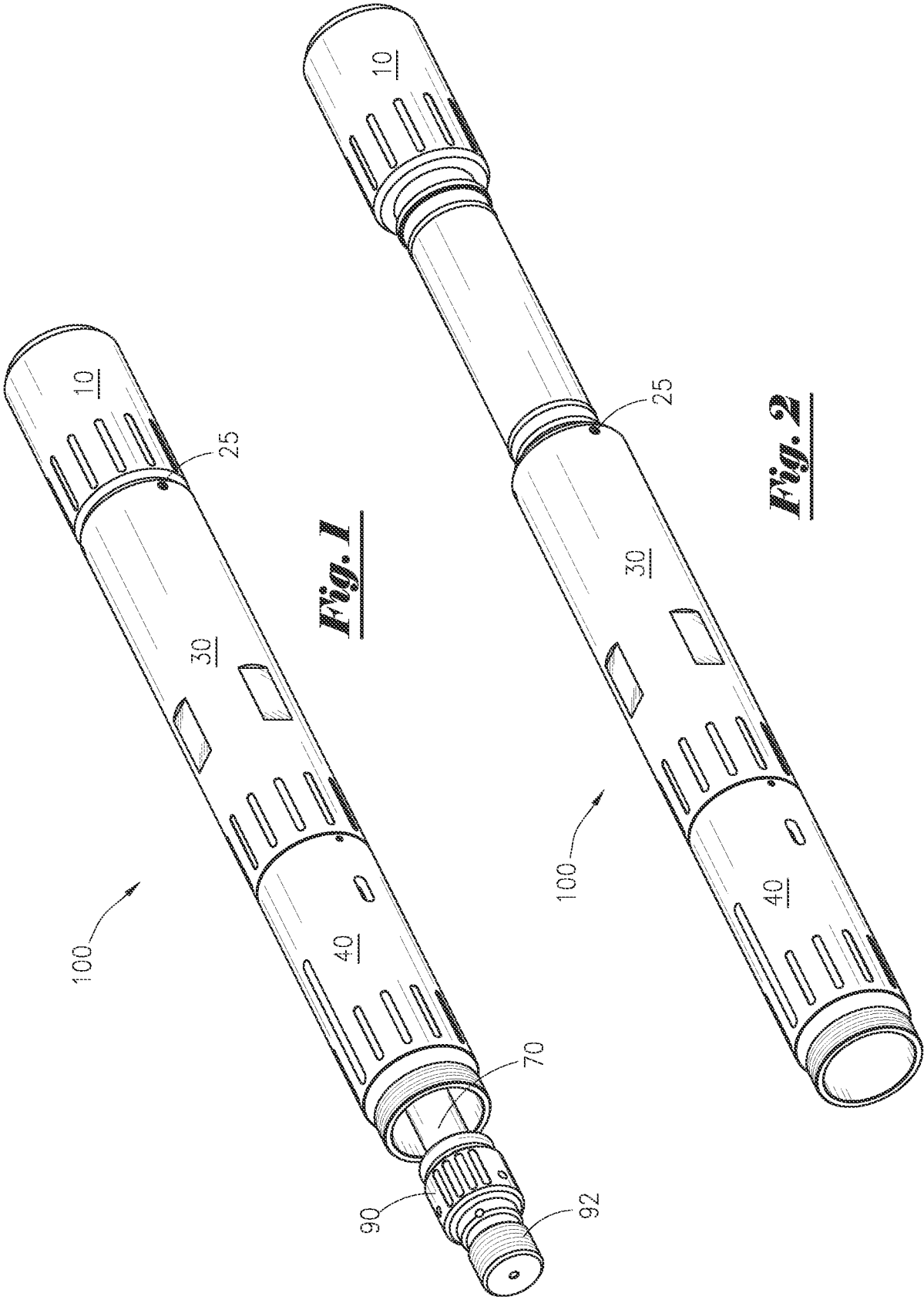

Fig. 1

Fig. 2

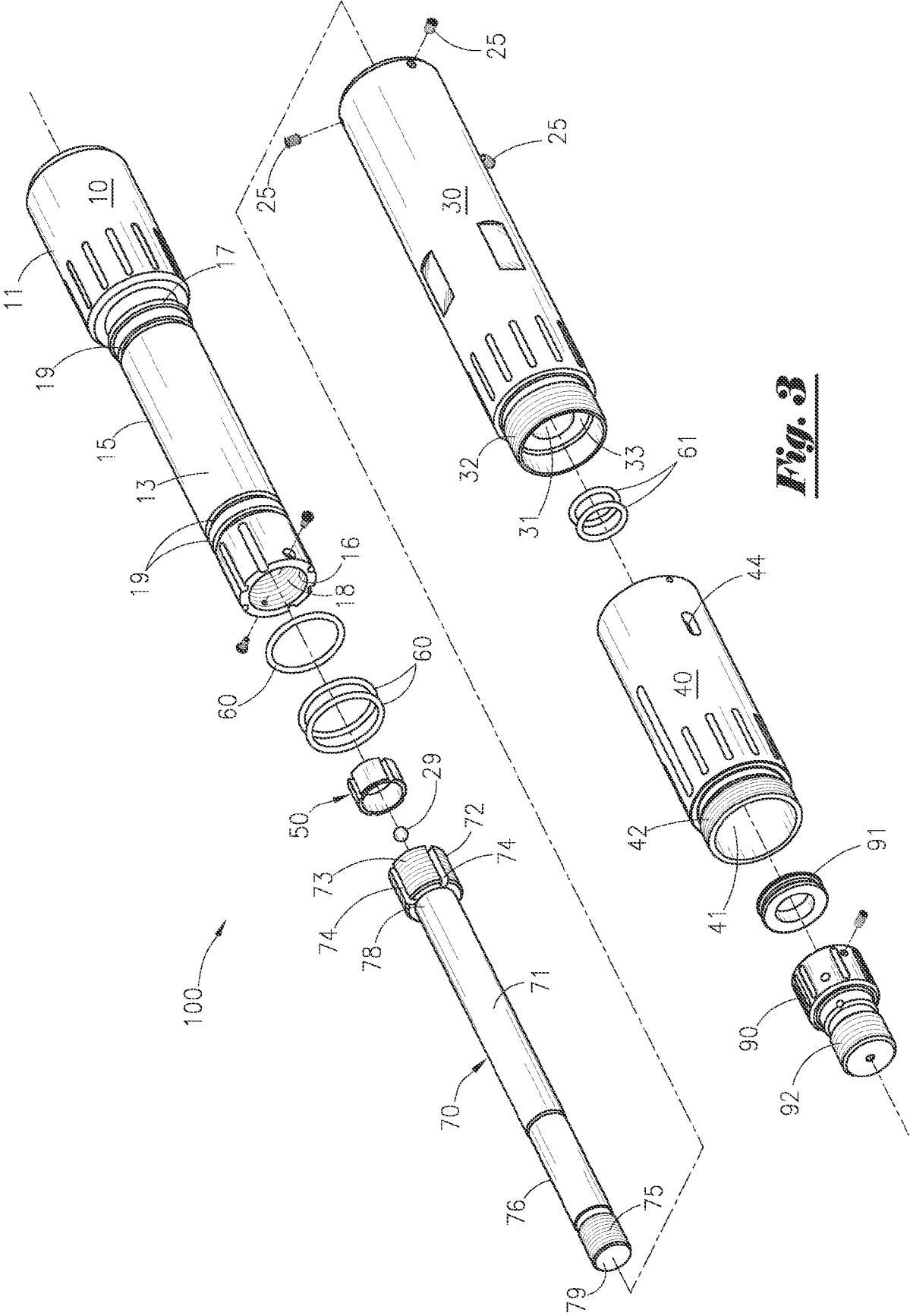

Fig. 3

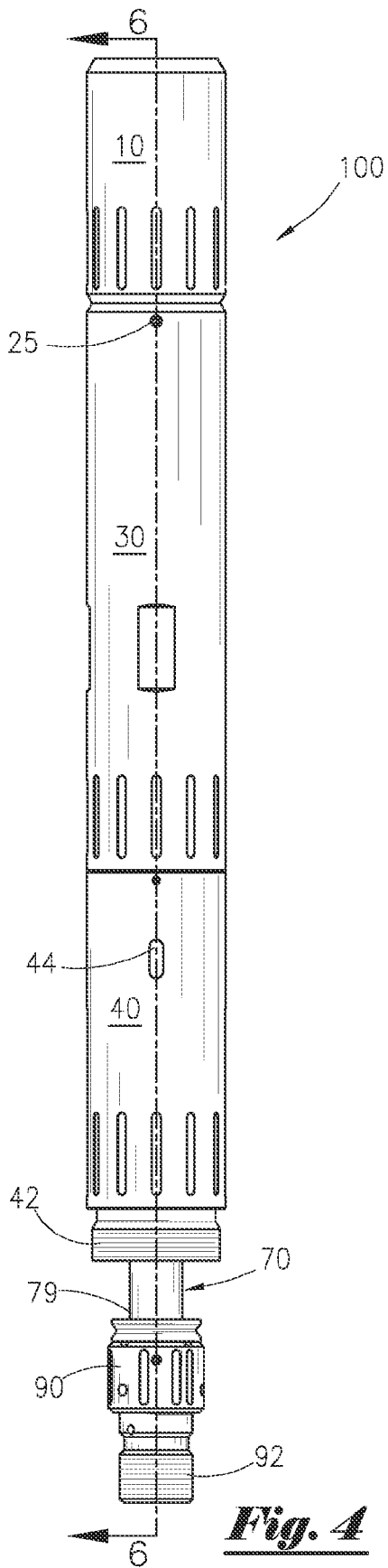

Fig. 4

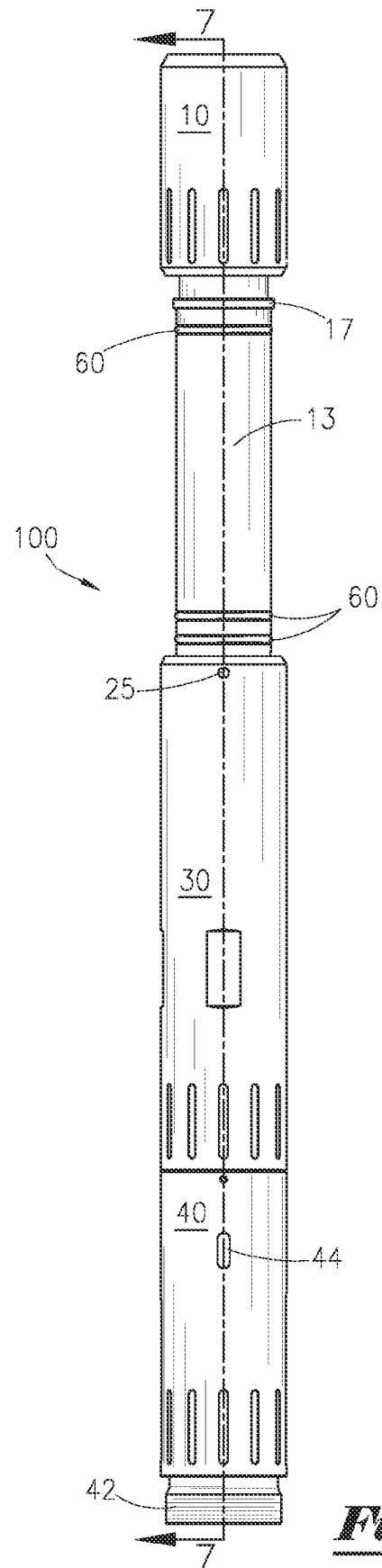

Fig. 5

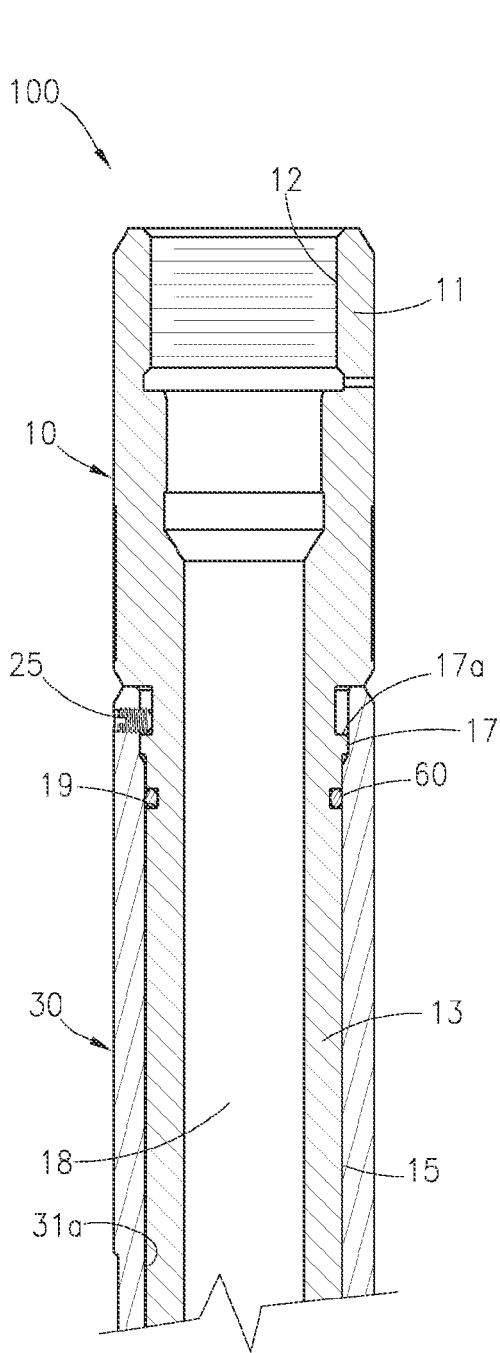

Fig. 6A

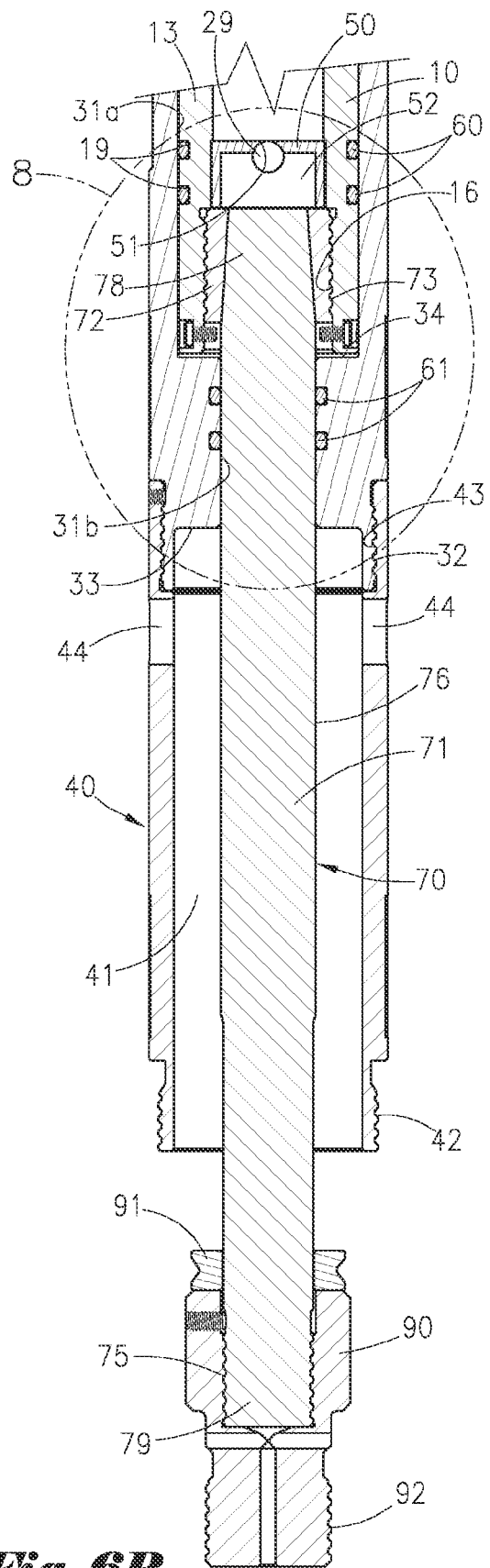

Fig. 6B

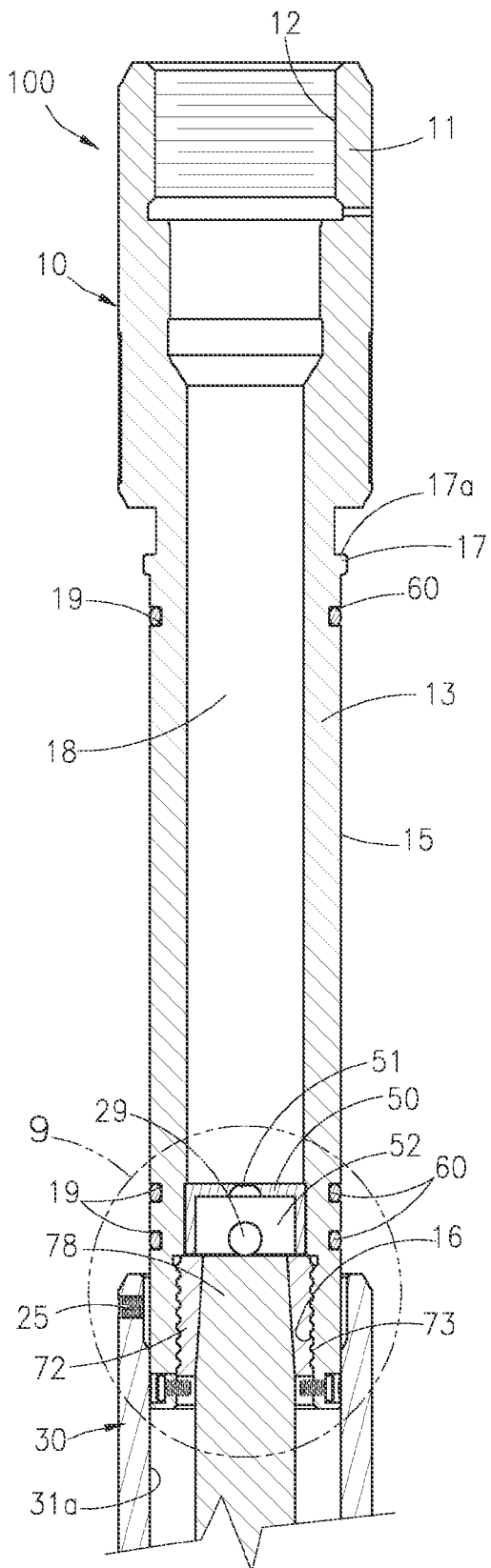

Fig. 7A

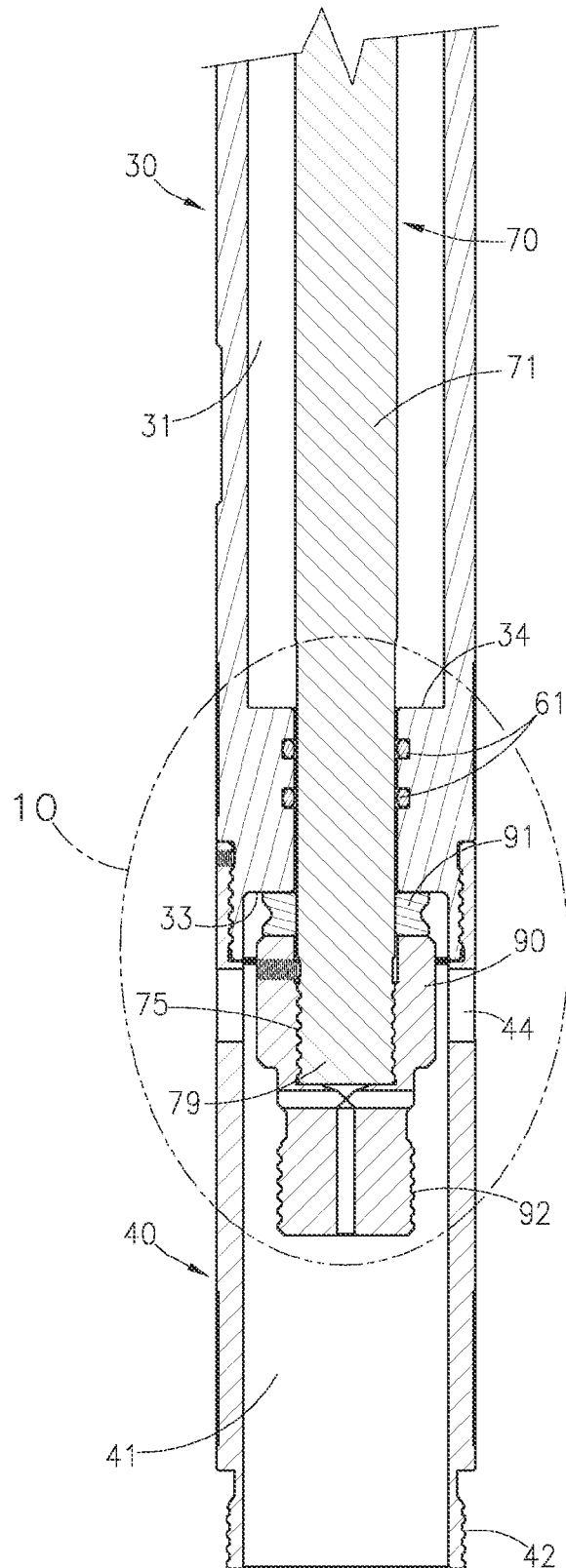

Fig. 7B

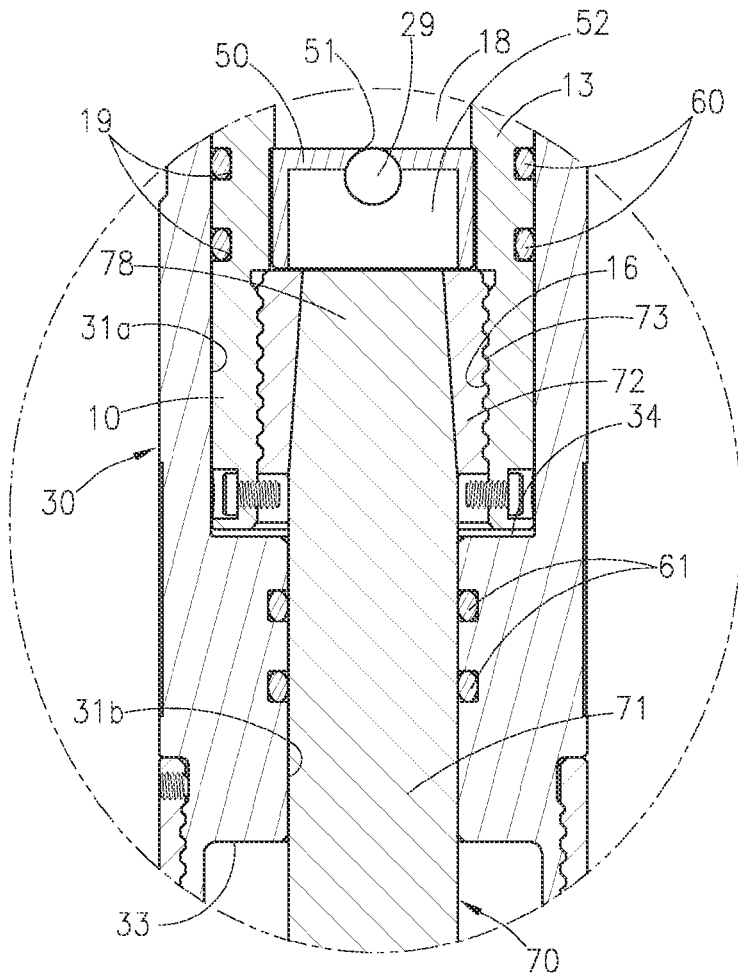

Fig. 8

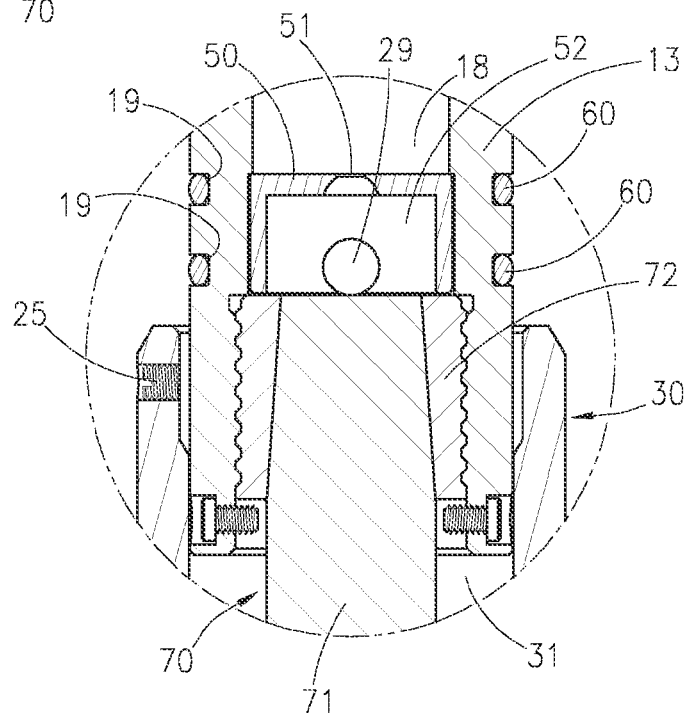

Fig. 9

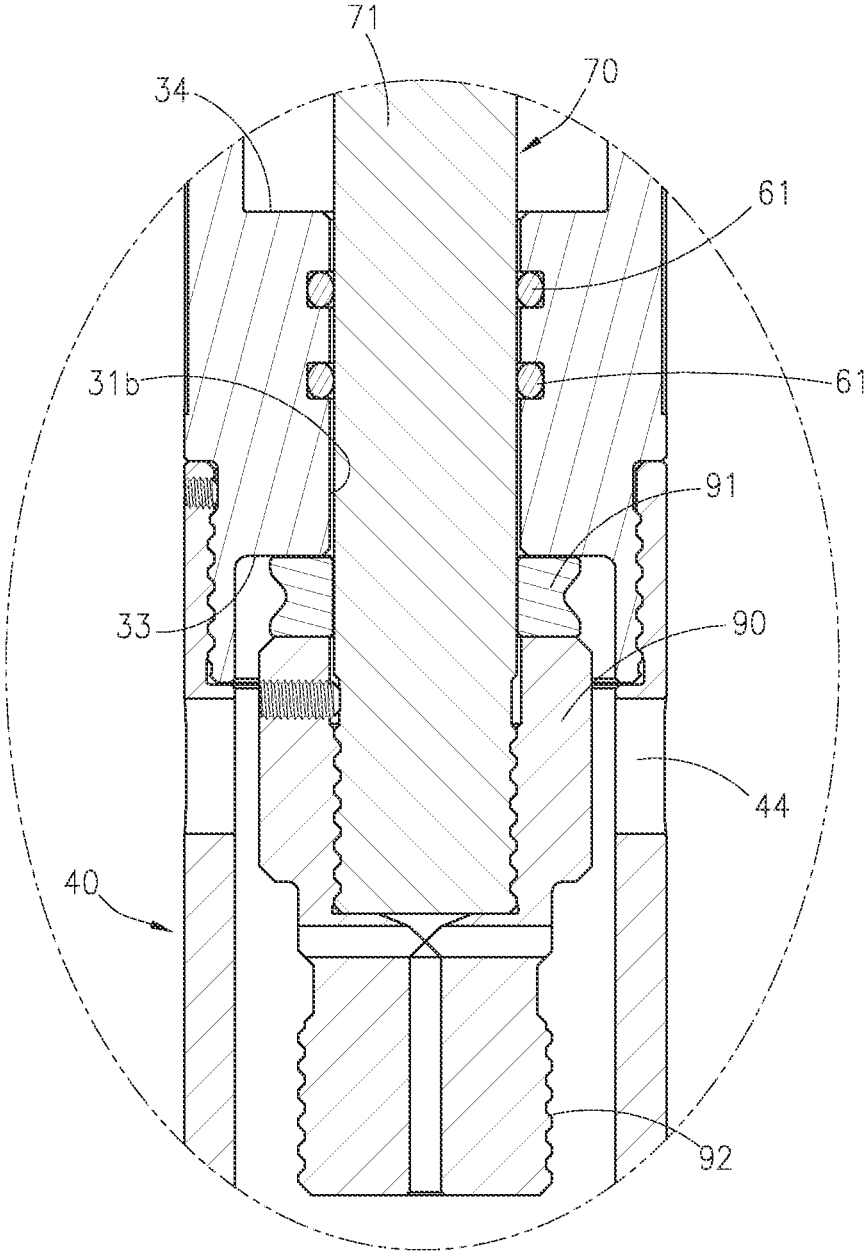

Fig. 10

METHOD AND APPARATUS FOR SETTING DOWNHOLE PLUGS AND OTHER OBJECTS IN WELLBORES

BACKGROUND OF THE INVENTION

1. Field of the Invention

[0001] The present invention pertains to a setting tool that can be used to set plugs and other downhole equipment within wellbores. More particularly, the present invention pertains to a compact and cost-efficient setting tool that can be conveyed via wireline for setting downhole tools and other equipment with wellbores.

2. Brief Description of the Prior Art

[0002] Wells are typically drilled into the earth's crust using a drilling rig or other similar equipment. After a section of wellbore has been drilled to a desired depth, a string of pipe known as casing is typically conveyed into said well and cemented in place. The casing is often installed to provide structural integrity to the wellbore and to keep geologic formations isolated from one another.

[0003] In some applications, a wireline tool string may be run into the wellbore after the casing has been installed in a well. Although many different configurations are possible, the wireline tool string may include a downhole plug that may be set within the inner bore of the casing string at a desired location in the wellbore, as well as a setting tool for setting said downhole plug. Generally, such a plug is used to isolate one portion of a wellbore from another. Although this operation is commonly used in many different operations, such wellbore plugs are commonly used in connection with hydraulic fracturing operations.

[0004] Conventional downhole wireline setting tools (for example, a "Baker 20") are long, complex, and require multiple personnel to handle. Thus, it would be beneficial to have a downhole wireline setting tool that is shorter and lighter than conventional setting tools. Further, the setting tool should beneficially have less components, be capable of being redressed and reused more quickly, and be easier to operate than conventional wireline setting tools.

SUMMARY OF THE INVENTION

[0005] The present invention comprises a wireline conveyed, gas driven setting tool designed to set downhole tools, such as fracturing ("frac") plugs, zone isolation plugs, bridge plugs, cement retainers, and packers. The setting tool of the present invention is functioned by igniting a power charge inside a firing head. As said power charge burns, the combustion generates gas that acts upon a piston area to stroke setting components of the apparatus.

[0006] The setting tool of the present invention generally comprises pressure sub, upper sleeve member, lower sleeve member, central tension mandrel, and tension mandrel adapter. In a preferred embodiment, the central longitudinal axes of each of said pressure sub, upper sleeve member, lower sleeve member and central tension mandrel are all oriented substantially parallel to each other. The lower sleeve member is secured to upper sleeve member which, in turn, is secured against movement along the length of central tension mandrel using at least one shear screw (or pin).

[0007] The setting tool is functioned by selectively igniting a power charge inside of a pressure chamber formed within said pressure sub. As the power charge burns, it generates gas that acts upon a piston area to shear said shear screw(s) and stroke the setting tool. A dampening medium or media, as well as an optimized flow area at or near the distal end of the setting tool, act to slow or regulate the setting stroke. When stroked, said upper sleeve member and lower sleeve member are displaced along the longitudinal axis of said tension mandrel, thereby causing an attached downhole plug or other object to be set according to a process understood by those in the art that, for clarity and conciseness, is not described in detail in this disclosure.

[0008] The setting tool of the present invention is shorter and lighter than conventional setting tools. Further, the setting tool of the present invention has less components, can be redressed in a fraction of the time compared to conventional setting tools, and can be efficiently operated by a single person. Unlike many conventional setting tools, the setting tool of the present invention does not require oil to dampen setting force. As a result, the setting tool of the present invention requires less parts and seal areas (potential leak paths), while eliminating risk for human error (that is, forgetting the oil entirely or loading the incorrect volume of oil).

[0009] The setting tool of the present invention utilizes a dampening assembly within said setting tool to slow the setting stroke of the tool; such dampening effect is frequently beneficial when setting tools and other equipment downhole within a wellbore. Additionally, an optimized flow area at or near the bottom or distal end of the setting tool also acts to slow said setting stroke.

BRIEF DESCRIPTION OF DRAWINGS/FIGURES

[0010] The foregoing summary, as well as any detailed description of the preferred embodiments, is better understood when read in conjunction with the drawings and figures contained herein. For the purpose of illustrating the invention, the drawings and figures show certain preferred embodiments. It is understood, however, that the invention is not limited to the specific methods and devices disclosed in such drawings or figures.

[0011] FIG. 1 depicts a side perspective view of the setting tool apparatus of the present invention in a retracted or "un-stroked" configuration.

[0012] FIG. 2 depicts a side perspective view of the setting tool apparatus of the present invention in an extended or "stroked" configuration.

[0013] FIG. 3 depicts a side perspective and exploded view of the setting tool apparatus of the present invention.

[0014] FIG. 4 depicts a side view of the setting tool apparatus of the present invention in a retracted or "un-stroked" configuration.

[0015] FIG. 5 depicts a side view of the setting tool apparatus of the present invention in an extended or "stroked" configuration.

[0016] FIG. 6A depicts a first portion of the setting tool apparatus of the present invention along line 6-6 of FIG. 4.

[0017] FIG. 6B depicts a second portion of the setting tool apparatus of the present invention along line 6-6 of FIG. 4.

[0018] FIG. 7A depicts a first portion of the setting tool apparatus of the present invention along line 7-7 of FIG. 5.

[0019] FIG. 7B depicts a second portion of the setting tool apparatus of the present invention along line 7-7 of FIG. 5.

[0020] FIG. 8 depicts a detailed view of the highlighted area depicted in FIG. 6B.

[0021] FIG. 9 depicts a detailed view of the highlighted area depicted in FIG. 7A.

[0022] FIG. 10 depicts a detailed view of the highlighted area depicted in FIG. 7B.

DETAILED DESCRIPTION OF A PREFERRED EMBODIMENT OF THE INVENTION

[0023] While the present invention will be described with reference to preferred embodiments, it will be understood by those skilled in the art that various changes may be made and equivalents may be substituted for elements thereof without departing from the scope of the present invention. In addition, many modifications may be made to adapt a particular situation or material to the teachings of the invention without departing from the essential scope thereof. Therefore, it is intended that the present invention not be limited to the particular embodiments disclosed as the best mode contemplated for carrying out this invention, but that the invention will include all embodiments (and legal equivalents thereof).

[0024] Moreover, it will be understood that various directions such as “upper”, “lower”, “bottom”, “top”, “left”, “right”, and so forth are made only with respect to explanation in conjunction with the drawings, and that components may be oriented differently, for instance, during transportation and manufacturing as well as operation. Because many varying and different embodiments may be made within the scope of the concept(s) herein taught, and because many modifications may be made in the embodiments described herein, it is to be understood that the details herein are to be interpreted as illustrative and non-limiting. As used herein, the term “sub” is intended to generically refer to a section or a portion of a tool string. While a sub may be modular and use threaded connections, no particular configuration is intended or implied by the use of the term sub.

[0025] FIG. 1 depicts a side perspective view of setting tool apparatus 100 of the present invention in a retracted or “un-stroked” configuration. As depicted in FIG. 1, said setting tool apparatus 100 generally comprises pressure sub 10, upper sleeve member 30, lower sleeve member 40, central tension mandrel 70 and tension mandrel adapter 90. In a preferred embodiment, the central longitudinal axes of each of said pressure sub 10, upper sleeve member 30, lower sleeve member 40 and central tension mandrel 70 are all oriented substantially parallel to each other. In the configuration depicted in FIG. 1, lower sleeve member 40 is secured to upper sleeve member 30 which, in turn, is secured against movement along the length of central tension mandrel 70 using at least one shear screw (or pin) 25.

[0026] FIG. 2 depicts a side perspective view of setting tool apparatus 100 of the present invention in an extended or “stroked” configuration. As depicted in FIG. 2, said at least one shear screw 25 has been sheared. As a result, upper sleeve member 30 and attached lower sleeve member 40 are capable of movement along the length of central tension mandrel 70. In the configuration depicted in FIG. 2, said upper sleeve member 30 and lower sleeve member 40 are displaced along the longitudinal axis of said tension

mandrel 70, thereby exposing at least a portion of body section 13 of pressure sub 10.

[0027] FIG. 3 depicts a side perspective and exploded view of setting tool apparatus 100 of the present invention. Setting tool apparatus 100 generally comprises pressure sub 10, upper sleeve member 30, lower sleeve member 40, central tension mandrel 70 and tension mandrel adapter 90. In a preferred embodiment, the central longitudinal axes of each of said pressure sub 10, upper sleeve member 30, lower sleeve member 40, central tension mandrel 70 and tension mandrel adapter 90 are all oriented substantially parallel to each other.

[0028] Pressure sub 10 generally comprises upper connection member 11 and body section 13. In a preferred embodiment, said upper threaded connection member 11 comprises a female or “box-end” threaded connection having internal threads (not visible in FIG. 3) that is configured for operational attachment to a conventional wireline or other connection adapter. However, it is to be observed that other types of connection members having different thread types or other connection means can be employed without departing from the scope of the present invention. By way of illustration, but not limitation, a pin-end threaded connection or other attachment means can be employed.

[0029] As depicted in FIG. 3, pressure sub 10 further comprises body section 13 defining outer surface 15. Central through bore 18 extends through said pressure sub 10. Lower connection threads 16 are disposed near the lower or distal end of body section 13; in the embodiment depicted in FIG. 3, said lower connection threads 16 comprise internal threads disposed on the inner surface of central through bore 18. At least one circumferential groove 19 extends around body section 13 and is configured to receive elastomeric sealing elements, such as O-rings 60. Further, radial extension ring 17 extends at least partially around the circumference of, and has a greater outer diameter than, said body section 13.

[0030] Central tension mandrel 70 comprises an elongate and substantially rigid member having a first end 78, second end 79 and body section 71 there between. In a preferred embodiment, said body section 71 has a substantially cylindrical shape defining outer surface 76. Lower threads 75 are disposed near second end 79; in the embodiment depicted in FIG. 3, said threads 75 comprise external threads. At least one circumferential step-down or change in outer diameter 76 extends around body section 71 near the lower or distal end of said central mandrel 70.

[0031] Central tension mandrel 70 further comprises connection member 72 disposed at or near first end 78 of said central tension mandrel 70. In a preferred embodiment, said connection member 72 has external male threads 73 configured to mate with internal threads 16 of pressure sub 10. Further, at least one elongate flow path 74 (such as a groove or channel) extends through said threads 73. In a preferred embodiment, said at least one flow path 74 comprises a channel oriented substantially parallel to the longitudinal axis of body section 71 and substantially perpendicular to the direction or orientation of said threads 73; however, it is to be observed that said at least flow path can have a different orientation without departing from the scope of the present invention, so long as it permits flow of fluid past said connection member 72. Internal plug 50 having an aperture 51 (not visible in FIG. 3) is operationally attached to connection member 72. Ball 29 is disposed within said

internal plug **50** and is configured to selectively block said aperture **51** as more fully described herein.

[0032] Upper sleeve member **30** generally comprises a cylindrical member having a through bore **31** extending substantially along the longitudinal axis of said upper sleeve member **30**. Similarly, lower sleeve member **40** comprises a cylindrical member having a through bore **41** extending substantially along the longitudinal axis of said lower sleeve member **40**. At least one transverse side port **44** extends from said through bore **41** to the external surface of said lower sleeve member **40**. Lower threads **42** are disposed at or near the lower or distal end of lower sleeve member **40**.

[0033] Lower threads **32** are disposed at or near the lower or distal end of said upper sleeve member **30**; in a preferred embodiment, said threads **32** are configured to engage with mating threads disposed on the inner surface of central through bore **41** of lower sleeve member **40** (not visible in FIG. 3). In a preferred embodiment, the central longitudinal axes of each of said pressure sub **10**, upper sleeve member **30**, lower sleeve member **40**, central tension mandrel **70** and tension mandrel adapter **90** are all oriented substantially parallel to each other.

[0034] Cushion member **91** is received on tension mandrel **70**. In a preferred embodiment, said cushion member **91** comprises a resilient or padded material (such as an elastomeric or foam material) configured to lessen or dampen force exerted between members contacting each other. Tension mandrel adapter member **90** is secured at second end **79** of tension mandrel **70** using lower threads **75**.

[0035] FIG. 4 depicts a side view of setting tool apparatus **100** of the present invention in a retracted or “un-stroked” configuration. As depicted in FIG. 4, said setting tool apparatus **100** generally comprises pressure sub **10**, upper sleeve member **30**, lower sleeve member **40**, central tension mandrel **70** and tension mandrel adapter **90**. Tension mandrel adapter member **90** is secured near the lower or distal end (second end **79**) of tension mandrel **70**. Lower sleeve member **40** is secured to upper sleeve member **30** which, in turn, is secured against movement along the length of central tension mandrel **70** using at least one shear screw (or pin) **25**.

[0036] FIG. 5 depicts a side view of setting tool apparatus **100** of the present invention in an extended or “stroked” configuration. As depicted in FIG. 5, at least one shear screw **25** is sheared or separated and, as such, is not constrained from axial movement by radial extension ring **17** that extends at least partially around the circumference of said body section **13**. As a result, upper sleeve member **30** and attached lower sleeve member **40** are capable of movement along the longitudinal axis or length of central tension mandrel **70**.

[0037] Still referring to FIG. 5, said upper sleeve member **30** and lower sleeve member **40** are displaced along the longitudinal axis of said tension mandrel **70**, thereby exposing at least a portion of body section **13** of pressure sub **10**. In this configuration, O-rings **60** disposed around said body section **13** are no longer positioned to engage against central bore **31** of upper sleeve member **30**. Further, in the configuration depicted in FIG. 5, it is to be observed that lower threads **42** at the distal end of lower sleeve member **40** extend beyond tension mandrel adapter **90** (visible in FIG. 4 but not FIG. 5).

[0038] FIG. 6A depicts a first (upper) portion of setting tool apparatus **100** of the present invention along line 6-6 of FIG. 4, while FIG. 6B depicts a second (lower) portion

of said setting tool apparatus **100** of the present invention along line 6-6 of FIG. 4. Setting tool apparatus **100** generally comprises pressure sub **10**, upper sleeve member **30**, lower sleeve member **40**, central tension mandrel **70** and tension mandrel adapter **90**.

[0039] Referring to FIG. 6A, pressure sub **10** generally comprises upper connection member **11** and body section **13**. In a preferred embodiment, said upper threaded connection member **11** comprises a female or “box-end” threaded connection having internal threads **12** that are configured for operational attachment to a conventional wireline or other connection adapter.

[0040] Still referring to FIG. 6A, pressure sub **10** further comprises body section **13** defining outer surface **15**. Central through bore **18** extends through said pressure sub **10**, while lower connection threads **16** are disposed near the lower or distal end of body section **13**. Elastomeric sealing elements, such as O-rings **60**, are disposed within circumferential grooves extending around body section **13**; said O-rings **60** engage against inner surface **31a** of central bore **31** of upper sleeve member **30** in order to form a fluid pressure seal.

[0041] Further, radial extension ring **17** extends at least partially around the outer circumferential surface of said body section **13**. At least one shear screw **25** is disposed within a transverse bore extending through upper sleeve member **30** and engages against a shoulder surface **17a** of radial extension ring **17**; in this configuration, said at least one shear screw **25** prevents axial movement of upper sleeve member **30** (as well as any operationally attached components) along the longitudinal axis of central tension mandrel **70**.

[0042] Central tension mandrel **70** comprises an elongate and substantially rigid member having a first end **78**, second end **79** and body section **71** defining outer surface **76**. Elastomeric sealing elements, such as O-rings **61**, are disposed within circumferential grooves extending around body section **71**; said O-rings **61** engage against outer surface **76** of central mandrel **70** in order to form a fluid pressure seal in the un-stroked position. In a preferred embodiment, central bore **31** has a smaller ID in the vicinity of O-rings **61** than near O-rings **60**.

[0043] Central tension mandrel **70** further comprises connection member **72** disposed at or near first end **78** of said central tension mandrel **70**. In a preferred embodiment, said connection member **72** has external male threads **73** configured to mate with internal threads **16** of pressure sub **10**. Although not visible in FIG. 6B, at least one flow path **74** extends through said threads **73** and permits flow of fluid past connection member **72** as more fully described herein.

[0044] Internal plug or housing **50** having aperture **51** is operationally attached to connection member **72**. Said internal plug **50** further defines an inner chamber or void **52**. Ball **29** is moveably disposed within said inner chamber or void **52** of said internal plug **50**, and is configured to selectively seat against said internal plug **50** in order to selectively block or obstruct said aperture **51**.

[0045] Lower sleeve member **40** comprises a cylindrical member having a through bore **41** extending substantially along the longitudinal axis of said lower sleeve member **40**. At least one transverse side port **44** extends from said through bore **41** to the external surface of said lower sleeve member **40**, while threads **42** are disposed at or near the lower or distal end of lower sleeve member **40**. Threads **32** of upper sleeve member **30** are configured to engage with

mating threads 43 disposed on the inner surface of central through bore 41 of lower sleeve member 40. Cushion member 91 is received on tension mandrel 70. Tension mandrel adapter member 90 is secured at second end 79 of tension mandrel 70 using lower threads 75.

[0046] FIG. 8 depicts a detailed view of the highlighted area depicted in FIG. 6B. Central bore 18 extends through said pressure sub 10, while lower connection threads 16 are disposed near the lower or distal end of body section 13. Elastomeric sealing elements (O-rings) 60 engage against inner surface 31a of central bore 31 of upper sleeve member 30 in order to form a fluid pressure seal. Similarly, elastomeric sealing elements (O-rings 61) extend around body section 71 of tension mandrel 70; said O-rings 61 engage against outer surface 76 of central mandrel 70 in order to form a fluid pressure seal in the un-stroked position.

[0047] Connection member 72 is disposed at or near first end 78 of said central tension mandrel 70. Although not visible in FIG. 8, at least one flow path 74 extends through said threads 73 of connection member 72 and permits flow of fluid past said connection member 72 as more fully described herein. Internal plug 50 having aperture 51 defines an inner chamber or void 52. Ball 29 is moveably disposed within said inner chamber or void 52 of said internal plug 50, and is configured to selectively seat against said internal plug 50 in order to selectively block or obstruct aperture 51.

[0048] Setting tool 100 of the present invention maintains a fluid pressure that is supplied or energized by pressurized gas. Said fluid pressure is converted into force or kinetic energy used to displace a portion of said setting tool 100 that, in turn, axially displaces outer shifting sleeve component of a separate wellbore device (not shown). Thus, setting tool 100 of the present invention may be used to axially displace or otherwise move, shift, or load a separate wellbore device (not shown), such as a fracturing (“frac”) plug, packer, swage, bridge plug, or the like.

[0049] Referring to FIGS. 6A and 6B, a power charge is beneficially loaded into central bore 18 of pressure sub 10 which is configured to define a pressure chamber. Setting tool 100 can be operationally connected to a conventional bottom hole assembly of a wireline (such as, for example, a wireline bottom hole assembly that would be used with a “Baker 20” or other conventional setting tool), typically via upper threads 12 of pressure sub 10. Said setting tool 100 can also be connected at its distal end to a plug, packer or other tool to be set downhole within a wellbore using threads 92 of tension mandrel adapter 90 and threads 42 of lower sleeve 40. Thereafter, setting tool 100 of the present invention 10 and the attached device to be anchored within a wellbore are conveyed to a desired depth within said wellbore.

[0050] After the aforementioned assembly has been positioned at a desired setting depth within a wellbore, said power charge disposed within bore 18 (also sometimes referred to as a power charge chamber) is selectively ignited, typically by some actuation signal or other triggering action initiated at the surface and conveyed downhole to setting tool 100. As said charge burns, gas is generated and expands within said pressure chamber formed by bore 18. The design and manufacture of suitable power charges and their operation within setting tools of the type described herein is understood by those in the art and, for clarity and conciseness, is described further.

[0051] It is to be observed that said power charges may be commercially available, or specifically designed and manufactured for use in connection with setting tool 100 of the present invention. Further, it is to be understood that, in addition to any other ingredients or materials, said power charges may include at least a minimum amount of explosive or propellant material; said minimum amount of explosive or propellant material in said power charge can be expressed, for example, by weight. In a preferred embodiment, said a minimum explosive or propellant weight of said power charge may be in a range between 350 grams and 470 grams for a first size of setting tool 100, or in a range between 440 grams and 480 grams for a second (larger) size of setting tool 100. Additionally, said chamber formed by bore 18 can define a minimum volume for receiving a power charge. In a preferred embodiment, said volume of said chamber defined by bore 18 may be in a range between 14.5 cubic inches and 17.5 for a first size of setting tool 100, or in a range between 19.5 cubic inches and 26.5 cubic inches for a second (larger) size of setting tool 100. Notwithstanding the foregoing, it is to be observed that power charges having different amounts of explosive or propellant material, and setting tools having different sizes of chambers for receiving said power charges, may be employed without departing from the scope of the present invention.

[0052] FIG. 7A depicts a first (upper) portion of setting tool apparatus 100 of the present invention along line 7-7 of FIG. 5, while FIG. 7B depicts a second (lower) portion of said setting tool apparatus 100 of the present invention along line 7-7 of FIG. 5. FIG. 9 depicts a detailed view of the highlighted area depicted in FIG. 7A. In operation, setting tool 100 may be used to actuate and set a separate well tool (not shown) using a translating assembly well known to those in the art.

[0053] In a preferred embodiment, a force dampening assembly is beneficially disposed between said pressure chamber. Said force dampening assembly can comprise an internal plug 50 having a central aperture 51 and defining an inner space 52. Ball 29, as well as dampening material or media, is disposed within said inner space 52 formed by said internal plug 50. In the “running” or pre-stroke configuration, ball 29 is seated against and obstructs aperture 51.

[0054] Fluid pressure generated within said pressure chamber (bore 18) exerts force on ball 29, causing said ball 29 to become unseated from the seat formed by aperture 51 of internal plug 50. Said fluid (gas) pressure then forces dampening material or media disposed within inner chamber 52 of internal plug 50 through at least one flow path 74 (such as an elongate groove or flow channel) extending through threads 73 of connection member 72. (Said flow channels are not visible in FIGS. 7A and 7B, but can be seen in FIG. 3). Said flow path(s) 74 are designed to slow the expansion of gas in order to set the downhole tools more smoothly and evenly.

[0055] Unlike conventional setting tools which typically comprise some form of flow ports or holes in said pressure chamber (that can become easily clogged or plugged), in a preferred embodiment said optimized flow paths 74 may comprise grooves or channels. Said optimized flow areas permit fluid to flow past said connection member 72 and tension mandrel 70 in a controlled rate. Although other materials can be used without departing from the scope of the present invention, said dampening material or media can

comprise a high viscosity material such as grease or other flowable fluid that has a desired resistance to flow.

[0056] After a predetermined volume of dampening material or media has passed through said optimized flow paths **74**, said dampening material or media then applies pressure to the piston area defined by surface **34** of sleeve member **30**. A first set of sealing members comprises elastomeric sealing elements (O-rings) **60** that engage against inner surface **31a** of central bore **31** of upper sleeve member **30** in order to form a fluid pressure seal. A second set of sealing members comprises elastomeric sealing elements (O-rings **61**) that extend around body section **71** of tension mandrel **70**; in the un-stroked position (shown in FIGS. **6A** and **6B**), said O-rings **61** engage against outer surface **76** of central mandrel **70** in order to form a fluid pressure seal. However, it is to be observed that said O-rings **61** only engage and form said seal against the portion of tension mandrel **70** having the larger outer diameter, but not the (lower) portion of said mandrel **70** having the smaller outer diameter; hence no such fluid pressure seal is formed by O-rings **61** in the fully stroked configuration depicted in FIGS. **7A** and **7B**.

[0057] As the power charge gas further expands, the force generated by fluid pressure acting on piston surface **34** causes said at least one shear screw **25** to separate, thereby releasing the locking engagement of said shear screw **25** against shoulder **17a** of radial extension **17** and allowing downward movement of upper sleeve member **30** and attached lower sleeve member **40**. Such downward movement starts the setting process of the downhole tool by forcing the outer components downward while the inner components remain stationary.

[0058] After tension mandrel adapter **90** enters bore **41** of the lower pressure sleeve member **40**, the fluid bypass area (that is, the flow path formed by the annular space between the outer surface of the mandrel adapter **90** and the inner surface of bore **41** of lower sleeve member **40** is greatly reduced which acts as a mechanism to further regulate the setting stroke. As the power charge burns completely, the setting tool will reach its maximum stroke length; at this point, the downhole tool is completely set and released from setting tool **100**. Cushion **91** absorbs impact force between lower surface **33** of upper sleeve member **30** and tension mandrel adapter **90**, preventing damage from repeated impacts from multiple setting iterations. Outer components (upper sleeve member **30** and lower sleeve member **40**) are then free to stroke completely and reach a bleed off position.

[0059] After the stroke of setting tool **100** is complete, seals **60** reach the top of the upper pressure sleeve **30** which causes them to come off seat and allow the remaining gas pressure to bleed off. Also, seals **61** are permitted to reach the bottom of the tension mandrel **70**; because the lower portion of said mandrel **70** has a smaller outer diameter than the upper portion of said mandrel **70**, O-rings **61** no longer engage against said outer surface **76** of mandrel **70** (or form a fluid pressure seal) in said stroked portion. As a result, the fluid pressure seal formed by said O-rings **61** is released, thereby permitting any remaining fluid pressure to bleed off. Put another way, when setting tool **100** is in the fully stroked position, both sets of integral O-rings **60** and **61** are unseated, which guarantees bleed off of any internal pressure downhole. Furthermore, when setting tool **100** is in the fully stroked position, said O-rings **60** are all visible, thereby allowing users have positive visual confirmation

that setting tool **100** has been fully stroked from a safe distance.

[0060] Setting tool **100** can then be retrieved from a wellbore and can be redressed to be run again. In a preferred embodiment, it is to be observed that the dampening assembly of the present invention (typically comprising internal plug **50**, ball **29** and dampening material or media such as grease or other highly viscous fluid) can be separately removed from setting tool **100** of the present invention, and replaced as a separate modular and pre-loaded component to facilitate quick, efficient and cost effective redressing of setting tool **100**.

[0061] Setting tool **100** of the present invention greatly reduces the chances of unintended or inadvertent pre-setting. Shear screw(s) **25** are sized so that pulling on setting tool **100** with wireline cannot stroke the tool. A conventional wireline rope socket is weaker than said shear screw **25** or the sum of said shear screws' shear value; if setting tool **100** becomes stuck within a wellbore, the rope socket (weak point) will separate before setting tool **100** will stroke.

[0062] Additionally, the piston area of setting tool **100** is designed so that said setting tool will flood with wellbore fluids in the event of a catastrophic O-ring leak. Any pressure downhole would be balanced across the piston area, meaning that wellbore pressure cannot inadvertently stroke setting tool **100** (unlike conventional setting tools which can inadvertently stroke and if wellbore pressure enters the tool above the pistons).

[0063] Top and bottom connections of setting tool **100** are designed to plug directly into industry standard wireline equipment (i.e. firing head and wireline adapter kits for plugs). The structure, attachment, and use of both the firing head and the setting adapter (which are commercially available) is understood by those in the art and, for clarity and conciseness, is not described in detail in this disclosure. Setting tool **100** is more rigid than conventional setting tools in order to make the setting tool of the present invention less susceptible to bending when running into deviated wellbores.

[0064] Windows or apertures **44** in the lower pressure sleeve **40** allow easy access to wireline adapter kit set screws when the setting tool **100** is in the stroked position, thereby expediting the teardown process. Ports in the tension mandrel adapter allow wellbore pressure to enter the orifice above a ball on seat which helps to keep the ball in place upon release from the frac plug. Conventional tools without this feature tend to "suck" the ball off seat when the tool releases.

[0065] The above-described invention has a number of particular features that should preferably be employed in combination, although each is useful separately without departure from the scope of the invention. While the preferred embodiment of the present invention is shown and described herein, it will be understood that the invention may be embodied otherwise than herein specifically illustrated or described, and that certain changes in form and arrangement of parts and the specific manner of practicing the invention may be made within the underlying idea or principles of the invention.

What is claimed:

1. A gas operated tool for setting a downhole device in a wellbore, comprising:

- a) a pressure sub having a first end, a second end and an inner chamber defining a volume, wherein said inner chamber is configured to receive a power charge;
- b) a mandrel operationally attached to said second end of said pressure sub;
- c) a setting sleeve slidably disposed on a said mandrel, wherein said setting sleeve is configured to alternate between a first running position and a second setting position when axial force is applied to said setting sleeve; and
- d) a dampening assembly disposed between said inner chamber and said setting sleeve for regulating said axial force applied to said setting sleeve.
- 2.** The tool of claim 1, wherein said dampening assembly further comprises:
- a housing having an aperture and defining an inner space;
 - dampening material disposed within said inner space; and
 - an object moveably disposed within said inner space, wherein said object is configured to selectively block said aperture and prevent fluid flow out of said inner space through said aperture.
- 3.** The tool of claim 1, wherein said dampening material comprises grease or other flowable fluid.
- 4.** The tool of claim 2, wherein gas pressure generated by said power charge in said inner chamber applies force to said dampening material, and wherein said dampening material applies force to a piston surface of said setting sleeve.
- 5.** The tool of claim 1, wherein said setting sleeve is secured in said first running position using at least one separatable member.
- 6.** The tool of claim 5, wherein said at least separatable member comprises a shear screw, shear pin or shear ring.
- 7.** The tool of claim 4, wherein said force applied to said piston surface of said setting sleeve by said gas pressure causes said setting sleeve to shift from said first running position to said second setting position.
- 8.** The tool of claim 1, wherein said volume of said inner chamber is in a range between 14.5 and 17.5 cubic inches.
- 9.** The tool of claim 1, wherein said volume of said inner chamber is in a range between 19.5 and 26.5 cubic inches.
- 10.** The tool of claim 1, wherein said power charge contains an amount of explosive in a range between 350 grams and 470 grams.
- 11.** The tool of claim 1, wherein said power charge contains an amount of explosive in a range between 440 grams and 480 grams.
- 12.** A method for setting a downhole device in a wellbore comprising:
- providing a setting tool comprising:
 - a pressure sub having a first end, a second end and an inner chamber defining a volume, wherein said inner chamber is configured to receive a power charge;
 - a mandrel operationally attached to said second end of said pressure sub;
 - a setting sleeve slidably disposed on a said mandrel, wherein said setting sleeve is configured to alternate between a first running position and a second setting position when axial force is applied to said setting sleeve; and
 - a dampening assembly disposed between said inner chamber and said setting sleeve for regulating said axial force applied to said setting sleeve;
 - positioning said setting tool and said downhole device within said wellbore;
 - selectively igniting said power charge in said inner chamber to generate gas;
 - setting said downhole device in said wellbore; and
 - retrieving said setting tool from said wellbore.
- 13.** The method of claim 12, wherein said dampening assembly further comprises:
- a housing having an aperture and defining an inner space;
 - dampening material disposed within said inner space; and
 - an object moveably disposed within said inner space, wherein said object is configured to selectively block said aperture and prevent fluid flow out of said inner space through said aperture.
- 14.** The method of claim 13, wherein said dampening material comprises grease or other flowable fluid.
- 15.** The method of claim 13, wherein said gas applies force to said dampening material, and wherein said dampening material applies force to a piston surface of said setting sleeve.
- 16.** The method of claim 12, wherein said setting sleeve is secured in said first running position using at least one separatable member.
- 17.** The method of claim 12, wherein said volume of said inner chamber is in a range between 14.5 and 17.5 cubic inches.
- 18.** The method of claim 12, wherein said volume of said inner chamber is in a range between 19.5 and 26.5 cubic inches.
- 19.** The method of claim 12, wherein said power charge contains an amount of explosive in a range between 350 grams and 470 grams.
- 20.** The method of claim 12, wherein said power charge contains an amount of explosive in a range between 440 grams and 480 grams.

* * * * *