



US 20230369754A1

(19) **United States**

(12) **Patent Application Publication**
Hunter et al.

(10) **Pub. No.: US 2023/0369754 A1**

(43) **Pub. Date: Nov. 16, 2023**

(54) **PROTECTIVE STRUCTURE FOR
PROTECTING ANTENNA FROM DAMAGE**

(52) **U.S. Cl.**
CPC *H01Q 1/42* (2013.01)

(71) Applicant: **Verizon Patent and Licensing Inc.**,
Basking Ridge, NJ (US)

(57) **ABSTRACT**

(72) Inventors: **James Robert Hunter**, Fleetwood, NC
(US); **Kevin L Martin**, Azle, TX (US)

A protective structure, to protect an antenna from damage, is provided. The protective structure includes a body. The body defines one or more prong-receiving apertures in a first surface of the body, wherein through each aperture of the one or more prong-receiving apertures, the body is configured to receive a prong of one or more prongs of the antenna. The body defines a radio frequency (RF) connection aperture extending from the first surface of the body to a second surface of the body, wherein the body is configured to receive a cable through the RF connection aperture to couple a cable connector of the cable to an RF connector of the antenna.

(21) Appl. No.: **17/744,804**

(22) Filed: **May 16, 2022**

Publication Classification

(51) **Int. Cl.**
H01Q 1/42 (2006.01)

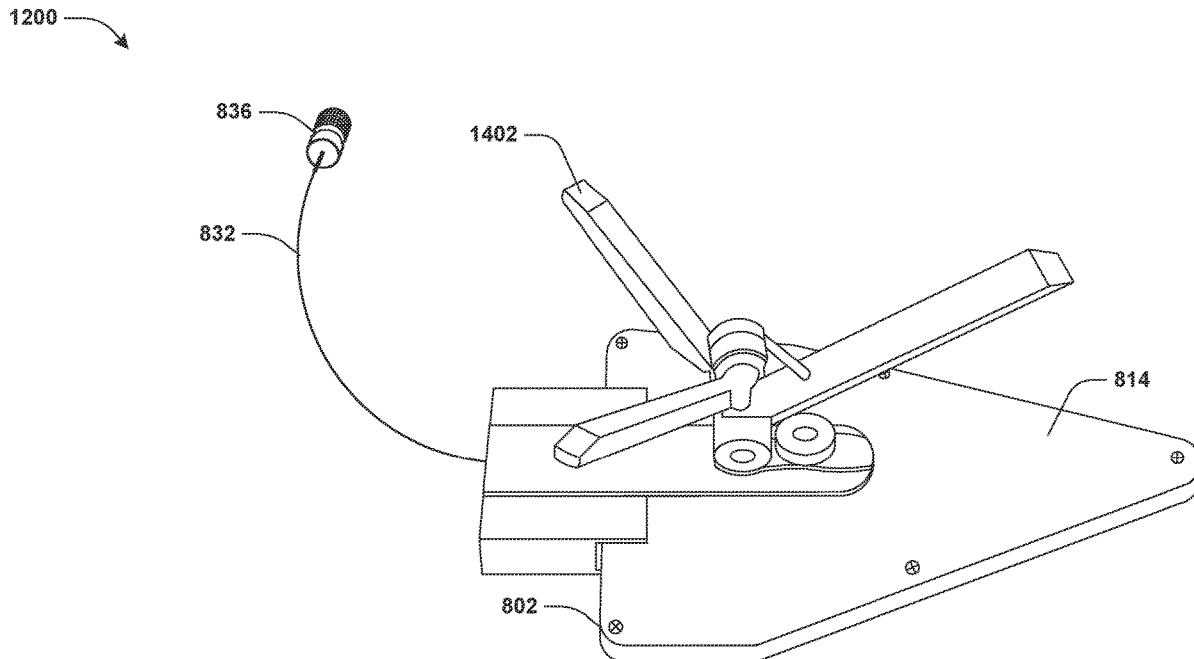

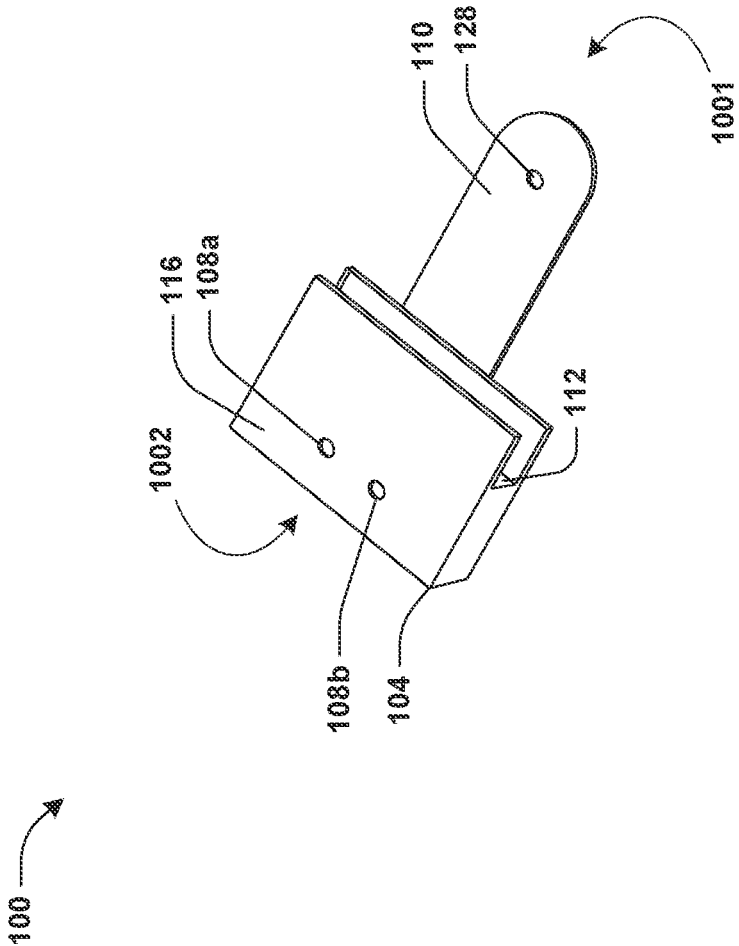

FIG. 1

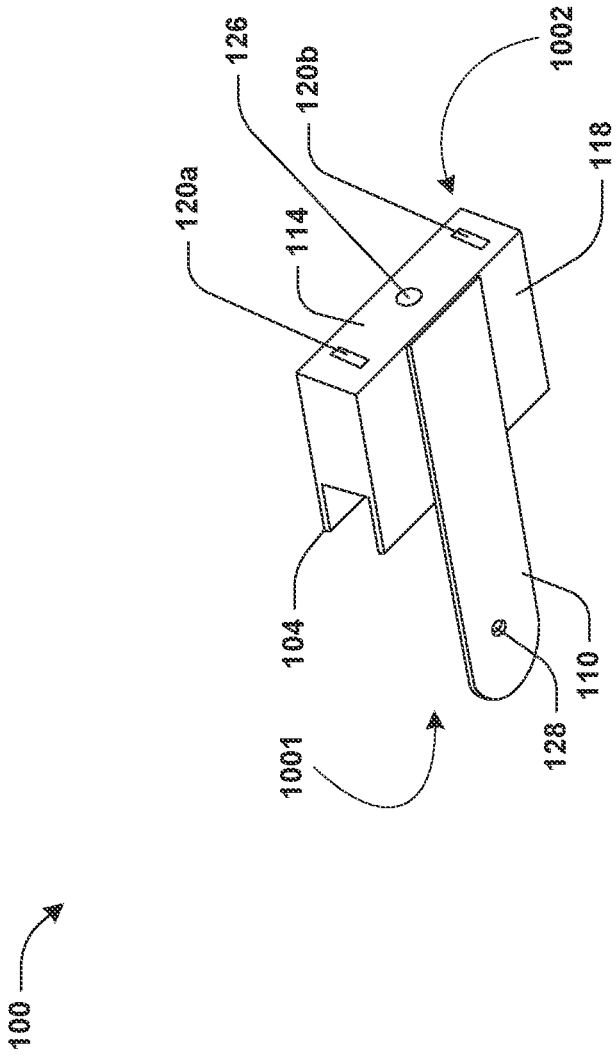

FIG. 2

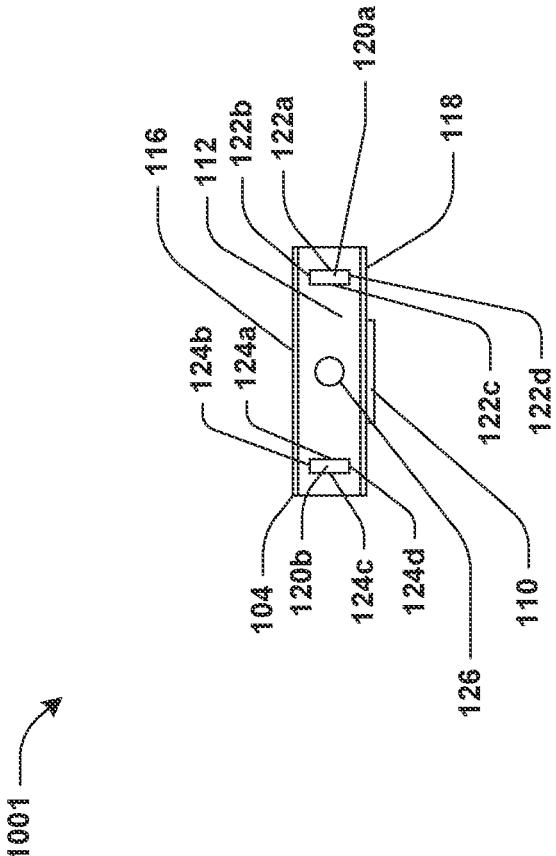

FIG. 3

1002 →

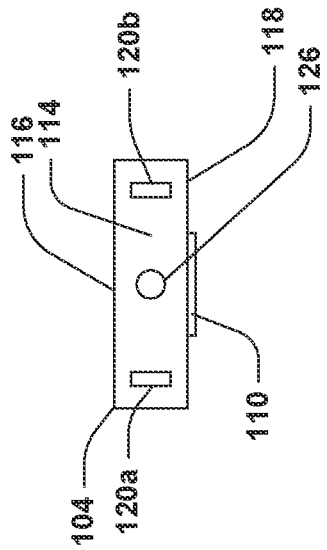

FIG. 4

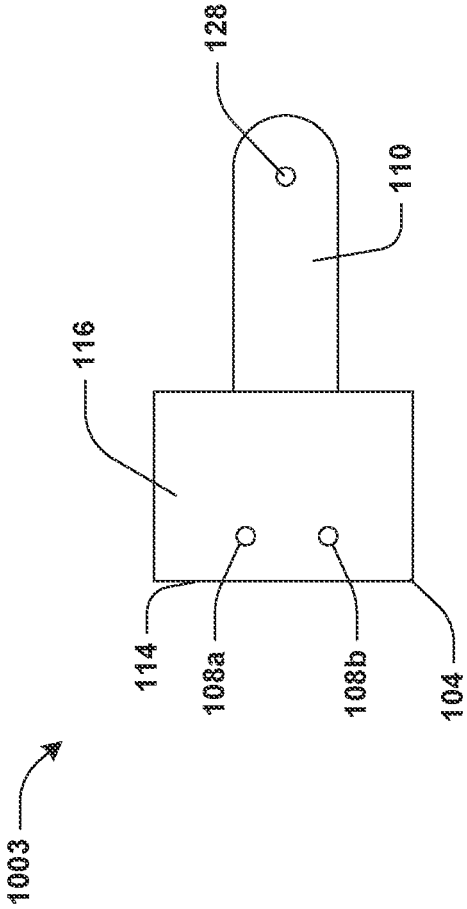

FIG. 5

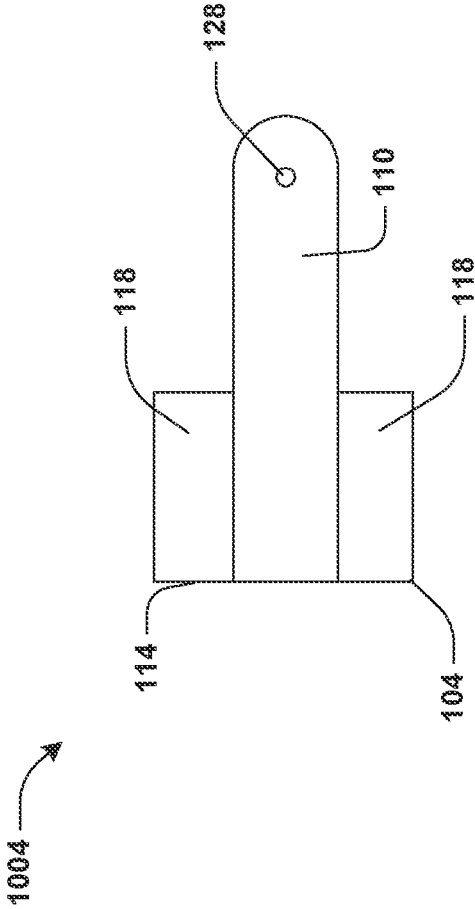

FIG. 6

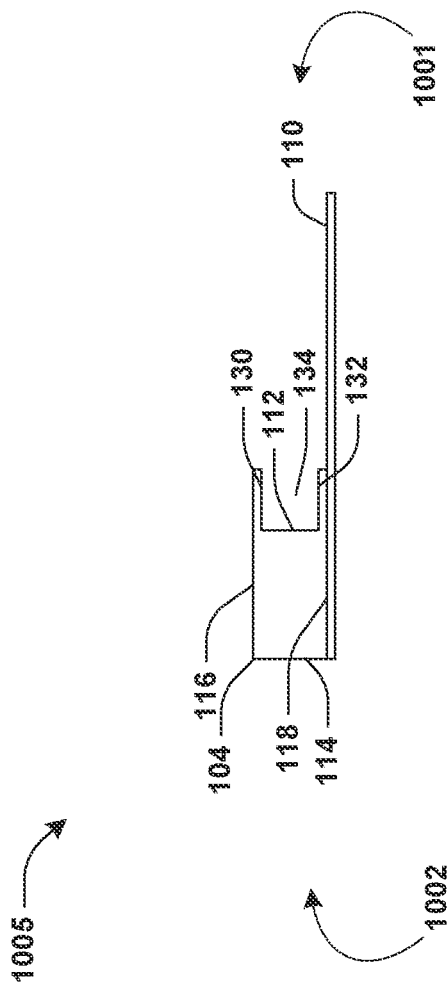

FIG. 7

8001 →

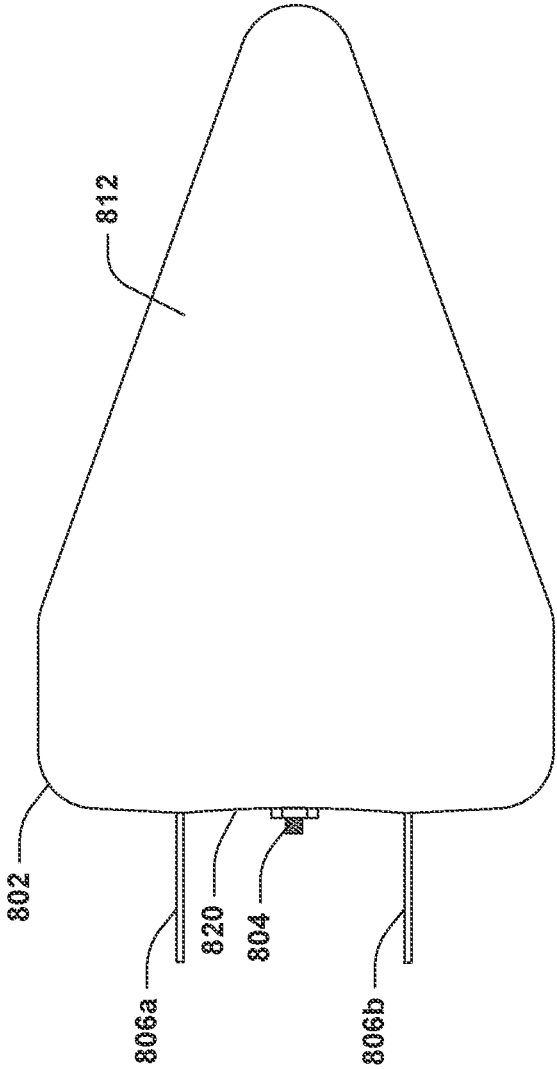

FIG. 8

8002 →

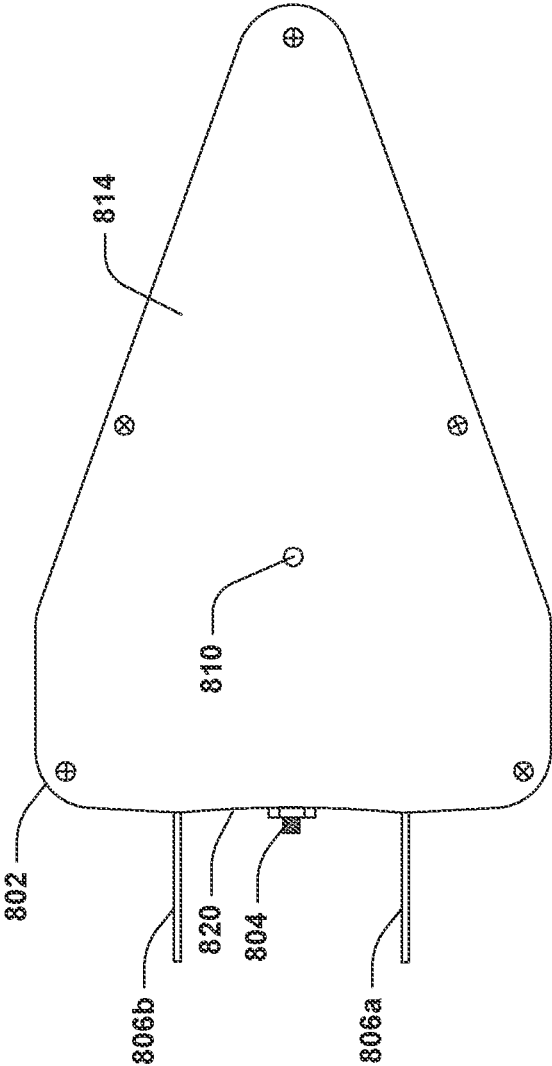

FIG. 9

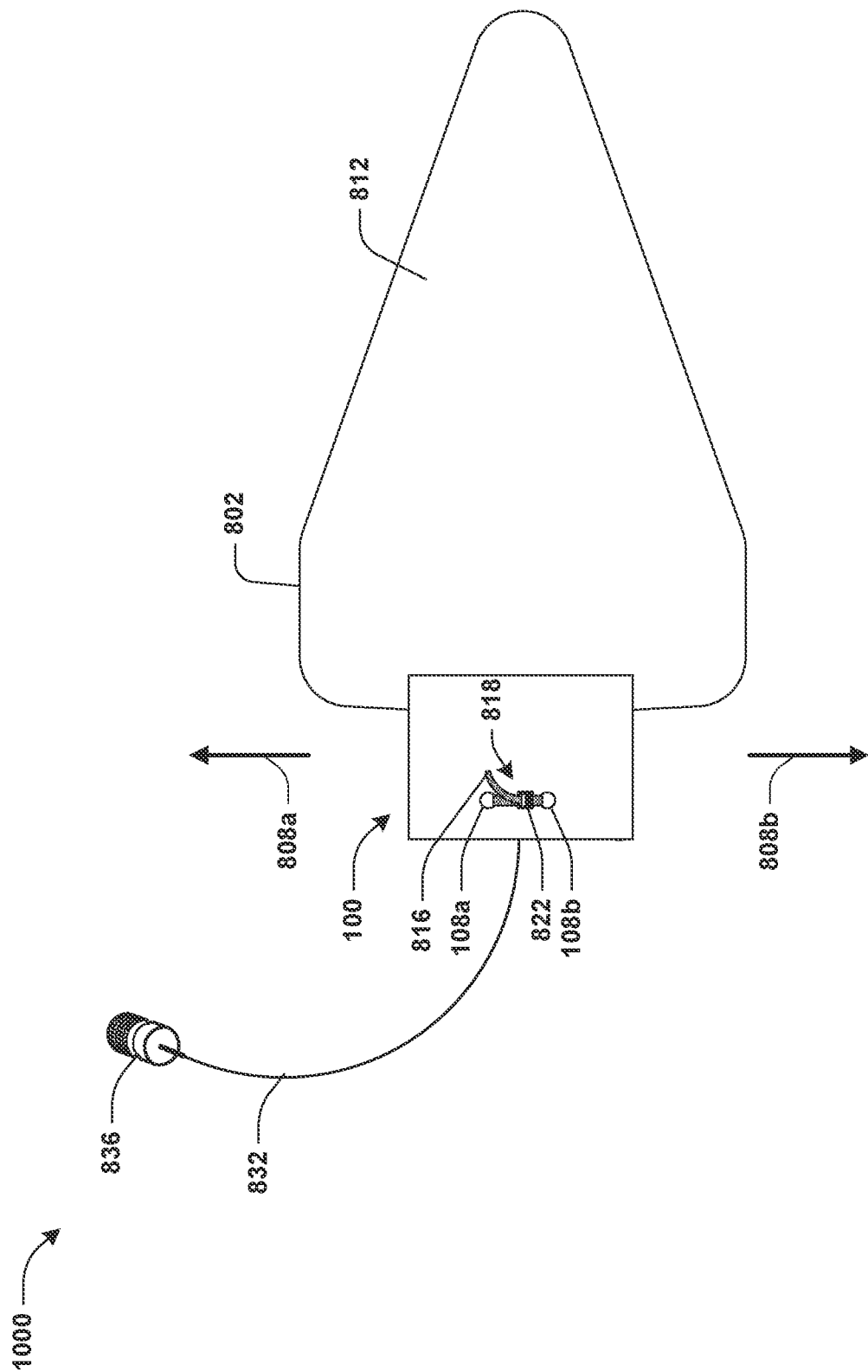

FIG. 10

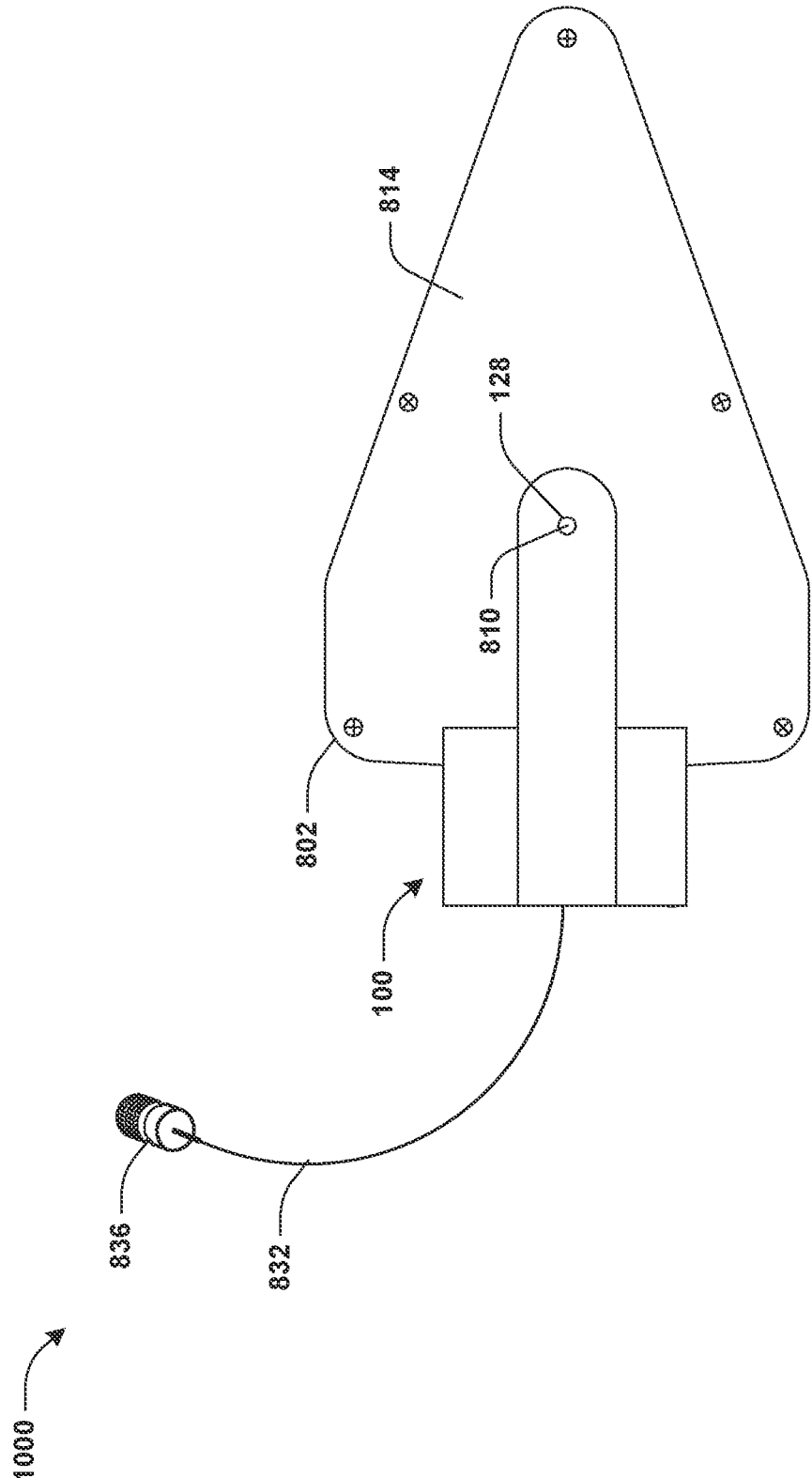

FIG. 11

1200

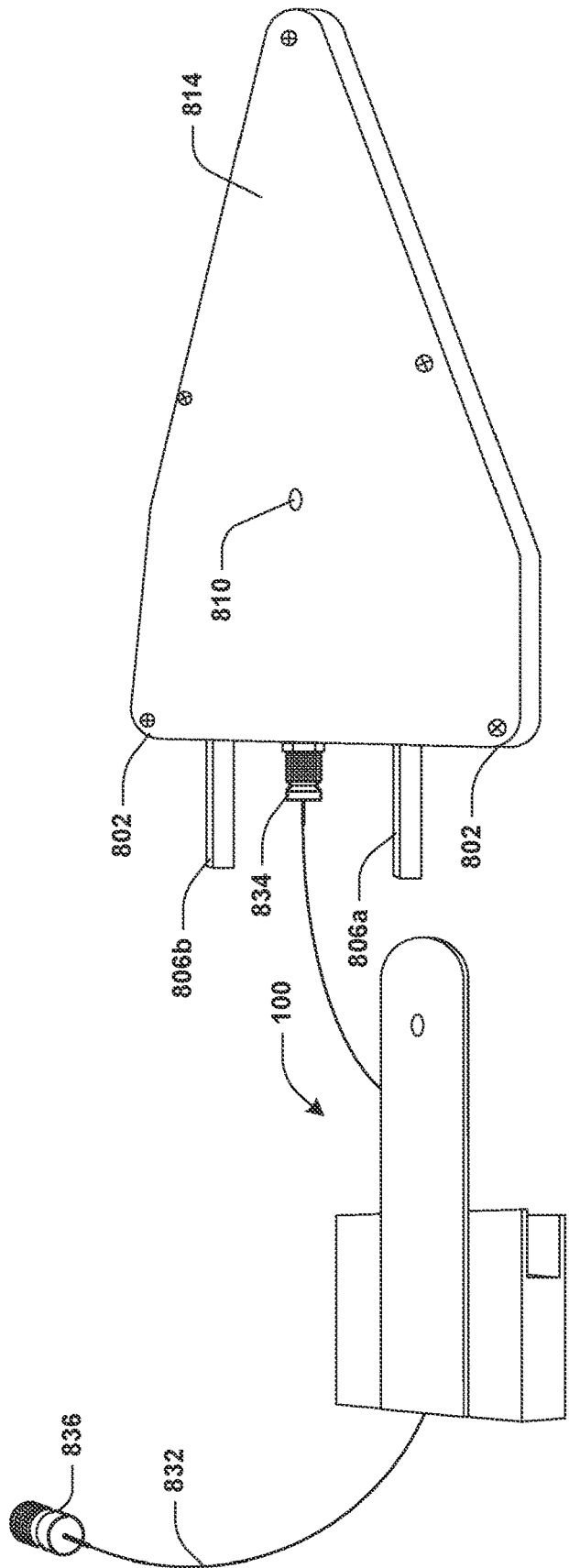

FIG. 12

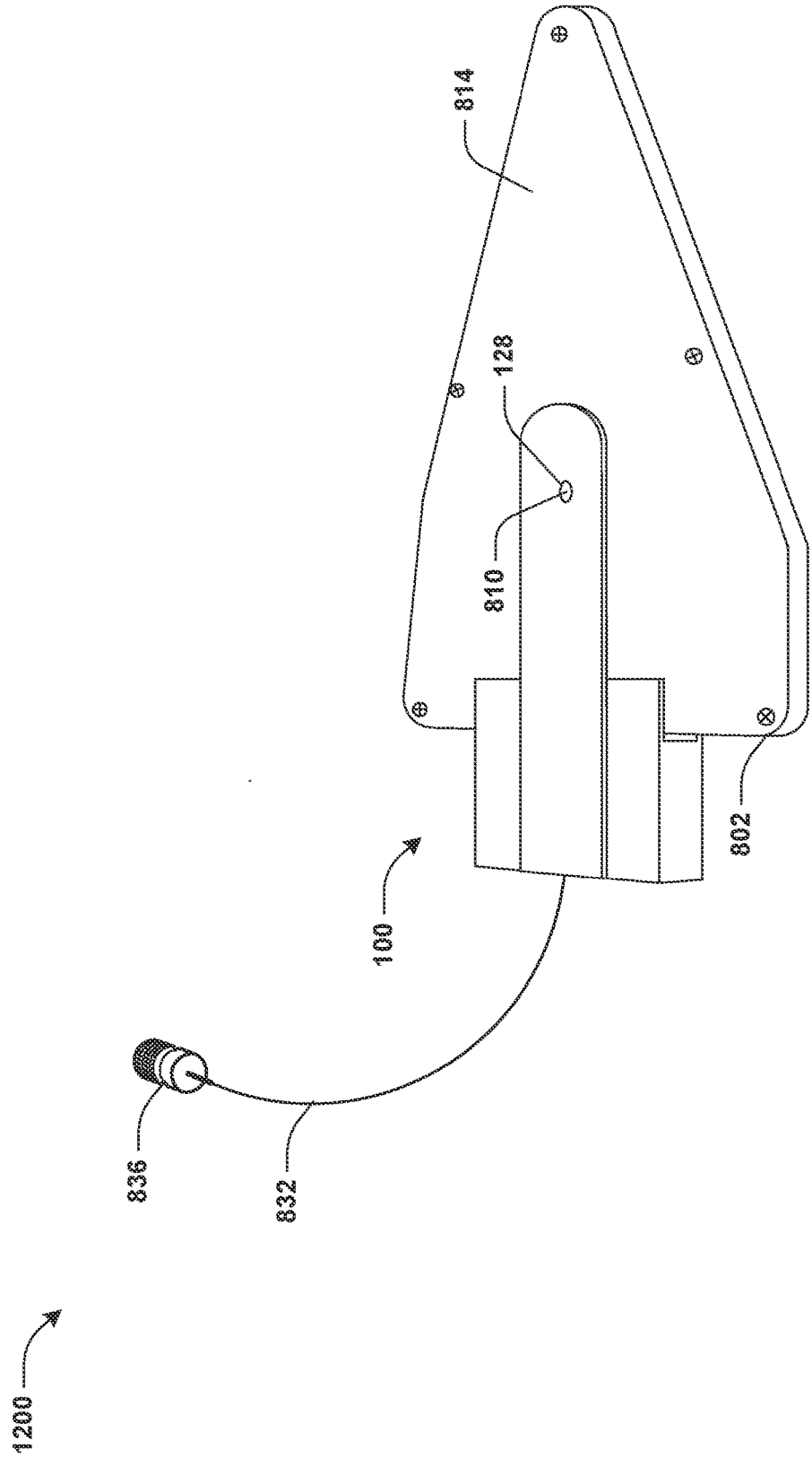

FIG. 13

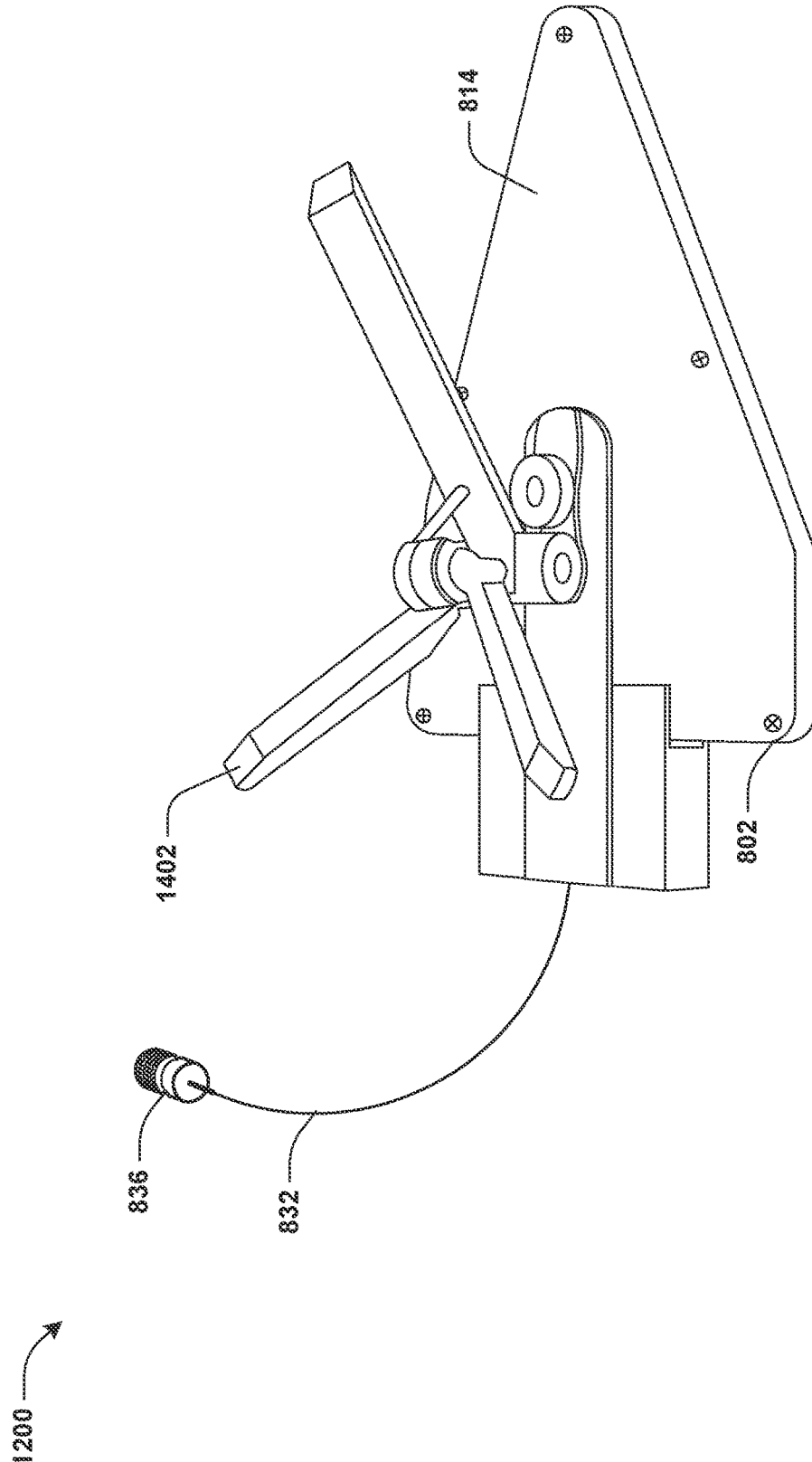

FIG. 14

101 →

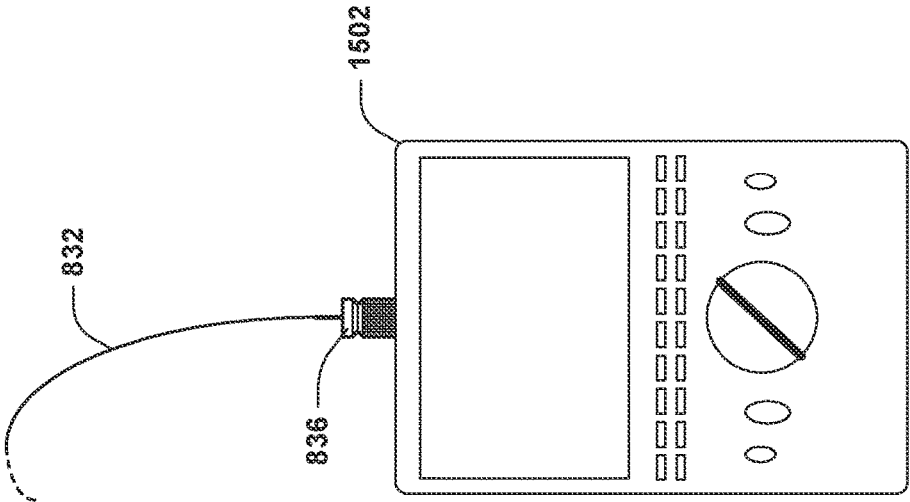

FIG. 15

PROTECTIVE STRUCTURE FOR PROTECTING ANTENNA FROM DAMAGE

BACKGROUND

[0001] An antenna may serve as an interface between radio waves propagating through space and electric currents in metal conductors. An antenna may be used with a transmitter and/or a receiver to send and/or receive signals.

BRIEF DESCRIPTION OF THE DRAWINGS

[0002] While the techniques presented herein may be embodied in alternative forms, the particular embodiments illustrated in the drawings are only a few examples that are supplemental of the description provided herein. These embodiments are not to be interpreted in a limiting manner, such as limiting the claims appended hereto.

[0003] FIG. 1 is an illustration of a first perspective view of a protective structure according to some embodiments.

[0004] FIG. 2 is an illustration of a second perspective view of a protective structure according to some embodiments.

[0005] FIG. 3 is an illustration of a first side of a protective structure according to some embodiments.

[0006] FIG. 4 is an illustration of a second side of a protective structure according to some embodiments.

[0007] FIG. 5 is an illustration of a third side of a protective structure according to some embodiments.

[0008] FIG. 6 is an illustration of a fourth side of a protective structure according to some embodiments.

[0009] FIG. 7 is an illustration of a fifth side of a protective structure according to some embodiments.

[0010] FIG. 8 is an illustration of a first side of an antenna according to some embodiments.

[0011] FIG. 9 is an illustration of a second side of an antenna according to some embodiments.

[0012] FIG. 10 is an illustration of a first side of an apparatus, comprising an antenna and a protective structure, according to some embodiments.

[0013] FIG. 11 is an illustration of a second side of an apparatus, comprising an antenna and a protective structure, according to some embodiments.

[0014] FIG. 12 is an illustration of a perspective view of an antenna and a protective structure according to some embodiments.

[0015] FIG. 13 is an illustration of a perspective view of an antenna and a protective structure according to some embodiments.

[0016] FIG. 14 is an illustration of a perspective view of an antenna and a protective structure according to some embodiments.

[0017] FIG. 15 is an illustration of a communication device 1502 according to some embodiments.

DETAILED DESCRIPTION OF EXAMPLE EMBODIMENTS

[0018] Subject matter will now be described more fully hereinafter with reference to the accompanying drawings, which form a part hereof, and which show, by way of illustration, specific example embodiments. This description is not intended as an extensive or detailed discussion of known concepts. Details that are well known may have been omitted, or may be handled in summary fashion.

[0019] The following subject matter may be embodied in a variety of different forms, such as structures, apparatuses, methods, devices, components, and/or systems. Accordingly, this subject matter is not intended to be construed as limited to any example embodiments set forth herein. Rather, example embodiments are provided merely to be illustrative.

[0020] The following provides a discussion of some types of scenarios in which the disclosed subject matter may be utilized and/or implemented.

[0021] An antenna may be used for transmission and/or reception of radio signals over radio waves. In an example, the antenna may comprise a broadband measurement antenna. For example, the antenna may be used for mobile measurement and/or direction finding applications. Alternatively and/or additionally, the antenna may be configured for electromagnetic interference (EMI) measurement and/or electromagnetic compatibility (EMC) measurement. The antenna may be coupled to a communication device, such as a receiver and/or a transmitter. For example, the antenna may be coupled to the communication device via a cable, such as a coaxial cable (e.g., a radio frequency (RF) coaxial cable). For example, a first cable connector of the cable (e.g., at a first end of the cable) may be coupled to a connector (e.g., an RF connector) of the antenna and a second cable connector of the cable (e.g., at a second end of the cable) may be coupled to the communication device. The communication device may comprise a measurement device configured to measure and/or detect electromagnetic interference (EMI), electromagnetic compatibility (EMC), etc. using the antenna. In an example, the communication device may comprise a spectrum analyzer (e.g., a spectrum analyzer for EMC measurement). The communication device 1502 and/or the antenna 802 may be used to measure RF performance. For example, the communication device and/or the antenna may be used to detect and/or identify interference sources that introduce interference that can degrade performance and/or a capacity associated with wireless communication between wireless communication sites and user equipments (UEs). For example, the interference may worsen a quality of telecommunication services provided by the wireless communication sites to the UEs, such as at least one of cellular service (e.g., 5G service, 4G service and/or other type of cellular service), internet service (e.g., cellular internet service, satellite internet service, 5G internet service, and/or other type of internet service), messaging service, etc. In response to identifying an interference source, corrective action may be taken to mitigate the interference source to improve network performance of one or more wireless communication sites.

[0022] However, one or more components associated with the antenna, such as the connector of the antenna, the cable coupled to the connector, etc., may be exposed and/or insufficiently protected from damage. Accordingly, the one or more components may become damaged due to collisions of the antenna with other objects (such as when the antenna is dropped onto the ground) and/or due to wear and tear on the cable and/or the connector during regular usage of the antenna, thus requiring that the one or more components (and/or the antenna) be replaced, repaired, etc.

[0023] Thus, in accordance with the present disclosure, a protective structure is provided that is configured to be attached to the antenna. The protective structure comprises a body with apertures that receive one or more prongs of the

antenna, the connector of the antenna and/or the cable. The protective structure may comprise a tongue (attached to the body, for example) with an aperture through which a mounting apparatus is attached to the antenna, wherein attaching the mounting apparatus to the antenna through the aperture attaches the antenna to the protective structure. When the protective structure is attached to the antenna, the protective structure may protect the one or more components (e.g., at least one of the connector, the cable, etc.) from damage and/or may increase a longevity of the antenna. The protective structure being attached to the antenna may not have a negative effect on performance of the antenna.

[0024] FIGS. 1-7 illustrate a protective structure 100, according to some embodiments. FIG. 1 illustrates a first perspective view of the protective structure 100. FIG. 2 illustrates a second perspective view of the protective structure 100. FIG. 3 illustrates a first side 1001 of the protective structure 100, which is also apparent in the first perspective view of FIG. 1. FIG. 4 illustrates a second side 1002 of the protective structure 100, which is also apparent in the second perspective view of FIG. 2. The first side 1001 of the protective structure 100 is opposite the second side 1002 of the protective structure 100. FIG. 5 illustrates a third side 1003 of the protective structure 100, which is also apparent in the first perspective view of FIG. 1. FIG. 6 illustrates a fourth side 1004 of the protective structure 100, which is also apparent in the second perspective view of FIG. 2. The third side 1003 of the protective structure 100 is opposite the fourth side 1004 of the protective structure 100. FIG. 7 illustrates a fifth side 1005 of the protective structure 100, which is also apparent in the first perspective view of FIG. 1.

[0025] The protective structure 100 may be configured to protect an antenna 802 (shown in FIGS. 8-14) from damage. For example, the protective structure 100 may be attached to the antenna 802 and/or may prevent and/or inhibit damage to a connector 804 (shown in FIGS. 8-9) of the antenna 802 and/or a cable 832 (shown in FIGS. 10-15) coupled to the connector 804. FIGS. 8-9 illustrate the antenna 802, according to some embodiments. FIG. 8 illustrates a first side 8001 (e.g., a top side), of the antenna 802, corresponding to a first surface 812 (e.g., a top surface) of the antenna 802. FIG. 9 illustrates a second side 8002 (e.g., a bottom side), of the antenna 802, corresponding to a second surface 814 (e.g., a bottom surface) of the antenna 802. FIGS. 10-11 illustrate an apparatus 1000, comprising the antenna 802 and the protective structure 100, when the protective structure 100 is attached to the antenna 802, according to some embodiments. FIG. 10 illustrates a first side (e.g., a top side), of the apparatus 1000, corresponding to the first surface 812 (e.g., the top surface) of the antenna 802. FIG. 11 illustrates a second side (e.g., a bottom side), of the apparatus 1000, corresponding to the second surface 814 (e.g., the bottom surface) of the antenna 802. FIGS. 12-14 illustrate perspective views of the antenna 802 and the protective structure 100, according to some embodiments.

[0026] Referring to FIG. 1, the protective structure 100 may comprise a body 104 and/or a tongue 110. The body 104 comprises a first surface 112 (shown in FIGS. 1, 3 and 7), a second surface 114 (shown in FIGS. 2 and 4-7), a third surface 116 (shown in FIGS. 1, 3-5, and 7), and/or a fourth surface 118 (shown in FIGS. 2-4 and 6-7).

[0027] The tongue 110 may be attached to the body 104 (e.g., the tongue 110 may be attached to the fourth surface

118 of the body 104). It will be appreciated that, as used herein, by being attached, the body 104 and the tongue 110 are not limited to comprising two separate structures that are attached. Rather, in an example, the body 104 and the tongue 110 may be integrally formed, one piece formed, a single composite piece, etc. In some examples, the body 104 and the tongue 110 may comprise two separate structures that are attached, such as with mechanical fasteners, welding, adhesives, etc. In some examples, the body 104 and the tongue 110 (e.g., the protective structure 100 as a whole) may be formed via at least one of 3D printing (e.g., using 3D printable material, such as 3D printable plastic), additive manufacturing, etc.

[0028] In some examples, the body 104 defines one or more prong-receiving apertures 120 (shown in FIGS. 2-4) in the first surface 112 of the body 104. For example, an aperture of the one or more prong-receiving apertures 120 may extend from the first surface 112 of the body 104 to the second surface 114 of the body 104. Although FIGS. 2-4 show an embodiment in which the one or more prong-receiving apertures 120 extend from the first surface 112 of the body 104 to the second surface 114 of the body 104, embodiments are contemplated in which the one or more prong-receiving apertures 120 extend merely partially through the body 104 such that the one or more prong-receiving apertures 120 do not reach the second surface 114.

[0029] In some examples, through each aperture of the one or more prong-receiving apertures 120, the body 104 is configured to receive a prong of one or more prongs 806 (shown in FIGS. 8-9 and 12) of the antenna 802. In an example, when the protective structure 100 is attached to the antenna 802, each prong of the one or more prongs 806 extends at least partially through an aperture of the one or more prong-receiving apertures 120. In an example, the one or more prong-receiving apertures 120 comprise a first prong-receiving aperture 120a and/or a second prong-receiving aperture 120b. The body 104 may be configured to receive a first prong 806a of the one or more prongs 806 through the first prong-receiving aperture 120a (e.g., when the protective structure 100 is attached to the antenna 802, the first prong 806a may extend at least partially through the first prong-receiving aperture 120a). The body 104 may be configured to receive a second prong 806b of the one or more prongs 806 through the second prong-receiving aperture 120b (e.g., when the protective structure 100 is attached to the antenna 802, the second prong 806b may extend at least partially through the second prong-receiving aperture 120b).

[0030] In some examples, the first prong-receiving aperture 120a is defined by a first plurality of inner sidewalls 122 (shown in FIG. 3) of the body 104. In an example, the first plurality of inner sidewalls 122 comprises at least three sidewalls. For example, the first plurality of inner sidewalls 122 may comprise four sidewalls 122a, 122b, 122c and 122d, wherein the sidewall 122a faces the sidewall 122c, and/or wherein the sidewall 122b faces the sidewall 122d. In some examples, when the protective structure 100 is attached to the antenna 802, one, some and/or all sidewalls of the first plurality of inner sidewalls 122 are in contact with the first prong 806a (that extends at least partially through the first prong-receiving aperture 120a). For example, one, some and/or all sidewalls of the first plurality of inner sidewalls 122 may be in contact with one, some and/or all outer sidewalls of the first prong 806a of the antenna 802. In

some examples, one or more sidewalls of the first plurality of inner sidewalls **122** (e.g., one, some and/or all sidewalls, of the first plurality of inner sidewalls **122**, that are in contact with the first prong **806a**) support (e.g., maintain) a position of the protective structure **100** relative to the antenna **802** and/or inhibit displacement of the protective structure **100** relative to the antenna **802** (when the protective structure **100** is attached to the antenna **802**). For example, when the protective structure **100** is attached to the antenna **802**, the one or more sidewalls may inhibit displacement of the protective structure **100** (relative to the antenna **802**) along a first direction **808a** and/or a second direction **808b** (shown in FIG. 10). In some examples, a first shape of the first prong-receiving aperture **120a** (e.g., a shape defined by the first plurality of inner sidewalls **122**) may match a second shape (e.g., a cross-sectional shape) of the first prong **806a** of the antenna **802**. In an example, such as shown in FIGS. 2-4, the first shape and the second shape may be rectangular, such as a rounded rectangle with one or more rounded corners (not shown) or a rectangle with sharp (e.g., non-rounded) corners. Embodiments are contemplated in which the first shape and the second shape are not rectangular, such as where the first shape and the second shape are triangular, circular, or other shape. A size of the first prong-receiving aperture **120a** may be about the same as (and/or larger than) a size (e.g., a cross-sectional size) of the first prong **806a** such that the first prong **806a** fits inside of the first prong-receiving aperture **120a**.

[0031] In some examples, the second prong-receiving aperture **120b** is defined by a second plurality of inner sidewalls **124** (shown in FIG. 3) of the body **104**. In an example, the second plurality of inner sidewalls **124** comprises at least three sidewalls. For example, the second plurality of inner sidewalls **124** may comprise four sidewalls **124a**, **124b**, **124c** and **124d**, wherein the sidewall **124a** faces the sidewall **124c**, and/or wherein the sidewall **124b** faces the sidewall **124d**. In some examples, when the protective structure **100** is attached to the antenna **802**, one, some and/or all sidewalls of the second plurality of inner sidewalls **124** are in contact with the second prong **806b** (that extends at least partially through the second prong-receiving aperture **120b**). For example, one, some and/or all sidewalls of the second plurality of inner sidewalls **124** may be in contact with one, some and/or all outer sidewalls of the second prong **806b** of the antenna **802**. In some examples, one or more sidewalls of the second plurality of inner sidewalls **124** (e.g., one, some and/or all sidewalls, of the second plurality of inner sidewalls **124**, that are in contact with the second prong **806b**) support (e.g., maintain) a position of the protective structure **100** relative to the antenna **802** and/or inhibit displacement of the protective structure **100** relative to the antenna **802** (when the protective structure **100** is attached to the antenna **802**). For example, when the protective structure **100** is attached to the antenna **802**, the one or more sidewalls inhibit displacement of the protective structure **100** (relative to the antenna **802**) along the first direction **808a** and/or the second direction **808b**. In some examples, a third shape of the second prong-receiving aperture **120b** (e.g., a shape defined by the second plurality of inner sidewalls **124**) may match a fourth shape (e.g., a cross-sectional shape) of the second prong **806b** of the antenna **802**. In an example, such as shown in FIGS. 2-4, the third shape and the fourth shape may be rectangular, such as a rounded rectangle with one or more rounded corners (not

shown) or a rectangle with sharp (e.g., non-rounded) corners. Embodiments are contemplated in which the third shape and the fourth shape are not rectangular, such as where the third shape and the fourth shape are triangular, circular, or other shape. A size of the second prong-receiving aperture **120b** may be about the same as (and/or larger than) a size (e.g., a cross-sectional size) of the second prong **806b** such that the second prong **806b** fits inside of the second prong-receiving aperture **120b**.

[0032] In some examples, the body **104** defines an RF connection aperture **126** (shown in FIGS. 2-4) extending from the first surface **112** of the body **104** to the second surface **114** of the body **104**. In some examples, the body **104** is configured to receive the cable **832** through the RF connection aperture **126** to couple a first cable connector **834** (shown in FIG. 12) of the cable **832** to the connector **804** (e.g., RF connector) of the antenna **802**. In some examples, when the protective structure **100** is attached to the antenna **802**, the cable **832** extends at least partially through the RF connection aperture **126**. In some examples, when the protective structure **100** is attached to the antenna **802**, at least a portion of the connector **804** of the antenna **802** may be within the RF connection aperture **126**. The first cable connector **834** of the cable **832** may be coupled to the connector **804** of the antenna **802** when the protective structure **100** is attached to the antenna **802**.

[0033] In some examples, the RF connection aperture **126** is between the first prong-receiving aperture **120a** and the second prong-receiving aperture **120b**. In some examples, a direction of extension of a prong-receiving aperture of the one or more prong-receiving apertures **120** (e.g., a direction of extension of the first prong-receiving aperture **120a** and/or the second prong-receiving aperture **120b**) is parallel to a direction of extension of the RF connection aperture **126**. Alternatively and/or additionally, the third surface **116** and/or the fourth surface **118** may be parallel to the direction of extension of the RF connection aperture **126** and/or may be parallel to a direction of extension of a prong-receiving aperture of the one or more prong-receiving apertures **120** (e.g., a direction of extension of the first prong-receiving aperture **120a** and/or the second prong-receiving aperture **120b**).

[0034] In some examples, the tongue **110** defines an antenna attachment aperture **128** (shown in FIGS. 1-2 and 5-6). The antenna **802** may comprise a first attachment unit **810** (shown in FIGS. 9 and 11-13). When the protective structure **100** is attached to the antenna **802**, the antenna attachment aperture **128** may be aligned with the first attachment unit **810** of the antenna **802** (such as shown in FIGS. 11 and 13). The antenna attachment aperture **128** may be used to attach a second attachment unit to the first attachment unit **810**. For example, the first attachment unit **810** and the second attachment unit may be fastened together via the antenna attachment aperture **128**. Fastening the second attachment unit to the first attachment unit **810** may attach the protective structure **100** to the antenna **802**. In some examples, the second attachment unit may be part of a mounting apparatus **1402** (shown in FIG. 14), such as at least one of a tripod, a handle, or other type of apparatus configured to mount and/or hold the antenna **802** in a position (e.g., a stable position). In an example in which the second attachment unit is part of a tripod, the first attachment unit **810** may comprise a tripod socket (e.g., an integrated tripod socket, such as an integrated 1/4-inch tripod

socket). Accordingly, fastening the second attachment unit to the first attachment unit **810** may attach the mounting apparatus **1402** and the protective structure **100** to the antenna **802** (such as shown in FIG. **14**). Embodiments are contemplated in which the second attachment unit is not part of the mounting apparatus **1402**, such as where the second attachment unit comprises a standalone fastener, such as at least one of a standalone screw, a standalone bolt, a standalone nut, etc.

[0035] In a first example, the first attachment unit **810** comprises a female thread (e.g., an internal thread) and the second attachment unit comprises a male thread (e.g., an external thread), such as where the second attachment unit comprises a male fastener (e.g., at least one of a screw, a bolt, etc.) and/or where the second attachment unit is fastened to the first attachment unit **810** via the antenna attachment aperture **128** (via engagement of the male thread of the second attachment unit with the female thread of the first attachment unit **810**). In the first example, the tongue **110** may be configured to receive the second attachment unit through the antenna attachment aperture **128** to attach the protective structure **100** (and/or the mounting apparatus **1402**) to the antenna **802** (via engagement of the male thread of the second attachment unit with the female thread of the first attachment unit **810**).

[0036] In a second example, the first attachment unit **810** comprises a male thread (e.g., an external thread) and the second attachment unit comprises a female thread (e.g., an internal thread), such as where the first attachment unit **810** comprises a male fastener (e.g., at least one of a screw, a bolt, etc.) and/or where the first attachment unit **810** is fastened to the second attachment unit via the antenna attachment aperture **128** (via engagement of the male thread of the first attachment unit **810** with the female thread of the second attachment unit). In the second example, the tongue **110** may be configured to receive the first attachment unit **810** through the antenna attachment aperture **128** to attach the protective structure **100** (and/or the mounting apparatus **1402**) to the antenna **802** (via engagement of the male thread of the first attachment unit **810** with the female thread of the second attachment unit).

[0037] In some examples, such as shown in FIG. **7**, the body **104** comprises a first protruding wall **130** and a second protruding wall **132**, wherein the first surface **112** of the body **104** may extend from the first protruding wall **130** to the second protruding wall **132**, and/or wherein the first protruding wall **130** may face the second protruding wall **132**. The first protruding wall **130** and/or the second protruding wall **132** and/or the first surface **112** may define a space **134** (shown in FIG. **7**) (e.g., a space between the first protruding wall **130** and the second protruding wall **132**). When the protective structure **100** is attached to the antenna **802**, a portion of the antenna **802** may be within the space **134**. In some examples, the first protruding wall **130** and/or the second protruding wall **132** are in contact with the antenna **802** when the protective structure **100** is attached to the antenna **802**. For example, the first protruding wall **130** may be in contact with the first surface **812** of the antenna **802** (shown in FIGS. **8** and **10**) and/or the second protruding wall **132** may be in contact with the second surface **814** of the antenna **802** (shown in FIGS. **8** and **11-14**) opposite the first surface **812** of the antenna **802**. The first surface **812** of the antenna **802** may correspond to a top surface of the antenna **802** and/or the second surface **814** of the antenna **802** may

correspond to a bottom surface of the antenna **802**. In some examples, the first protruding wall **130** and/or the second protruding wall **132** support (e.g., maintain) a position of the protective structure **100** relative to the antenna **802** and/or inhibit displacement of the protective structure **100** relative to the antenna **802** (when the protective structure **100** is attached to the antenna **802**).

[0038] In some examples, the body **104** defines one or more fastener-receiving apertures **108** (shown in FIGS. **1**, **5** and **10**) in the third surface **116** of the body **104**. The body **104** may be configured to receive a strain relief fastener, through the one or more fastener-receiving apertures **108**, to provide strain relief to the cable **832** and/or the connector **804** of the antenna **802**.

[0039] Referring to FIGS. **8-9**, the one or more prongs **806** and/or the connector **804** may be attached to a third surface **820** of a body of the antenna **802**. The third surface **820** may extend from the first surface **812** of the antenna **802** to the second surface **814** of the antenna **802**. It will be appreciated that, as used herein, by being attached, the body of the antenna **802** and the one or more prongs **806** are not limited to comprising separate structures that are attached. Rather, in an example, the body of the antenna **802** and the one or more prongs **806** may be integrally formed, one piece formed, a single composite piece, etc. In some examples, the body of the antenna **802** and the one or more prongs **806** may comprise separate structures that are attached, such as with mechanical fasteners, welding, adhesives, etc.

[0040] Referring to FIG. **10**, the strain relief fastener may comprise a cable tie **818**, such as at least one of a zip tie, a hose tie, a tie wrap, etc., and/or the strain relief fastener may comprise one or more other types of fasteners. In some examples, the one or more fastener-receiving apertures **108** comprise a first fastener-receiving aperture **108a** and a second fastener-receiving aperture **108b**. As the cable tie **818** is fed into the body **104** through a fastener-receiving aperture of the one or more fastener-receiving apertures **108**, the body **104** may be configured to channel the cable tie **818** to exit the body **104** through another fastener-receiving aperture of the one or more fastener-receiving apertures **108**. In an example, the body **104** may define a channel (not shown) between the first fastener-receiving aperture **108a** and the second fastener-receiving aperture **108b**. For example, a first end **816** of the cable tie **818** may be fed into the body **104** through the first fastener-receiving aperture **108a**, wherein the first end **816** may be conducted, by the channel, to the second fastener-receiving aperture **108b** and may exit the body **104** through the second fastener-receiving aperture **108b**. The first end **816** may correspond to a free end of the cable tie **818** (e.g., an end, of the cable tie **818**, that does not comprise a ratchet), and/or the first end **816** may be pointed. The first end **816** may be fed through a ratchet mechanism **822** (e.g., the ratchet mechanism **822** may comprise a case and/or a ratchet within the case). The ratchet mechanism **822** may be at a second end of the cable tie **818** opposite the first end **816** of the cable tie **818**. When the first end **816** is fed through the ratchet mechanism **822**, the ratchet of the ratchet mechanism **822** may engage with teeth (e.g., integrated teeth) along the cable tie **818** to prevent the first end **816** from being pulled back. The cable tie **818** may be further pulled through the ratchet mechanism **822** to tighten the cable tie **818**, wherein the ratchet of the ratchet mechanism **822** and/or the integrated teeth on the cable tie **818** may prevent the cable tie **818** from becoming undone. The cable

tie **818** may be fed through the one or more fastener-receiving apertures **108** and/or may be tightened while the cable **832** extends through the RF connection aperture **126** and/or while the first cable connector **834** is coupled to the connector **804** of the antenna **802**. Accordingly, the cable tie **818** may bind the cable **832** to an inner surface of the body **104**, where tightening the cable tie **818** may increase the binding strength applied to the cable **832** using the cable tie **818**. It may be appreciated that binding the cable **832** to the inner surface of the body **104** using the cable tie **818** may provide strain relief to the cable **832** and/or the connector **804** of the antenna **802**. Alternatively and/or additionally, binding the cable **832** to the inner surface of the body **104** using the cable tie **818** may protect the cable **832** and/or the connector **804** from damage, such as by way of mitigating strain on the cable **832** and/or the connector **804** during one or more of the following situations: (i) the antenna **802** is held up by the cable **832**, (ii) the cable **832** is pulled on, (iii) the antenna **802** falls and someone grabs the cable **832** to prevent the antenna **802** from hitting the ground, and/or (iv) one or more other situations (e.g., in these situations, a force, that would otherwise be absorbed by and/or damage the connector **804** if the cable **832** was not bound using the cable tie **818**, may be absorbed by the cable tie **818** and/or the cable **832** as a result of the cable **832** being bound using the cable tie **818**).

[0041] FIGS. 12-14 illustrate various stages of an example process **1200** for attaching the protective structure **100** to the antenna **802**. The example process **1200** may comprise: a first act comprising feeding the cable **832** through the RF connection aperture **126**; a second act (performed after the first act, for example) comprising coupling the first cable connector **834** of the cable **832** to the connector **804** of the antenna **802** (e.g., the configuration shown in FIG. 12 may be achieved by performing the first act and/or the second act); a third act (performed after the second act, for example) comprising positioning the protective structure **100** such that the antenna **802** at least partially fills the space **134** (shown in FIG. 7) and/or such that the antenna attachment aperture **128** is aligned with the first attachment unit **810** of the antenna **802** (e.g., the configuration shown in FIG. 13 may be achieved by performing the third act); and/or a fourth act (performed after the third act, for example) comprising fastening the second attachment unit to the first attachment unit **810** via the antenna attachment aperture **128** (e.g., the configuration shown in FIG. 14 may be achieved by performing the fourth act). The example process **1200** may comprise a fifth act (performed after the third act and/or the fourth act, for example) comprising feeding the cable tie **818** through the body **104** (via the one or more fastener-receiving apertures **108**) and/or binding the cable **832** to the inner surface of the body **104** using the cable tie **818**. Although FIG. 14 shows an example in which the second attachment unit is part of the mounting apparatus **1402** (e.g., the tripod), embodiments are contemplated in which the second attachment unit is part of a structure different than the mounting apparatus **1402** and/or in which the second attachment unit comprises a standalone fastener, such as at least one of a standalone screw, a standalone bolt, a standalone nut, etc. Fastening the second attachment unit to the first attachment unit **810** (via the antenna attachment aperture **128**) attaches the protective structure **100** to the antenna **802**.

[0042] When the protective structure **100** is attached to the antenna **802**, the protective structure **100** protects the

antenna **802** (e.g., the protective structure **100** protects the connector **804** of the antenna **802** and/or one or more other components of the antenna **802**) and/or the cable **832** (e.g., the protective structure **100** protects the first cable connector **834** of the cable **832**) from damage. For example, the protective structure **100** may act as a shock absorber and/or a damping device, wherein shock impulses, impacts, etc. are absorbed and/or damped by the protective structure **100** to inhibit and/or prevent damage to the antenna **802** and/or the cable **832**, to improve a mechanical stability of the antenna **802** and/or to reduce stress on the antenna **802** and/or the cable **832** (e.g., reduce stress on the connector **804** of the antenna **802** and/or on the first cable connector **834** of the cable **832**), thereby improving performance of the antenna **802** and/or increasing a longevity of the antenna **802**. In an example scenario in which a collision occurs (e.g., the antenna **802** is dropped onto the ground, an object collides with the antenna **802** and/or the protective structure **100**, etc.), the protective structure **100** may prevent and/or mitigate damage to the antenna **802** and/or the cable **832** by absorbing and/or damping an impact of the collision.

[0043] FIG. 15 illustrates a communication device **1502**, according to some embodiments. The communication device **1502** may comprise a receiver and/or a transmitter. The antenna **802** may be coupled to the communication device **1502** via the cable **832**. In some examples, the cable **832** may comprise a coaxial cable (e.g., an RF coaxial cable). The first cable connector **834** of the cable **832** (that is connected to the connector **804** of the antenna **802**) may comprise an RF coaxial connector. The second cable connector **836** of the cable **832** may comprise an RF coaxial connector. The connector **804** of the antenna **802** may comprise an RF coaxial connector. In some examples, the second cable connector **836** may be coupled to the communication device **1502**, such as coupled to a connector (e.g., an RF coaxial connector) of the communication device **1502**. Accordingly, communication device **1502** may transmit and/or receive a signal to and/or from the antenna **802** via the cable **832**.

[0044] The communication device **1502** may comprise a measurement device configured to measure and/or detect EMI, EMC, etc. using a signal from the antenna **802**. In an example, the communication device may comprise a spectrum analyzer (e.g., a spectrum analyzer for EMC measurement). The communication device **1502** and/or the antenna **802** may be used to measure RF performance. The communication device **1502** and/or the antenna **802** may be used to detect and/or identify interference sources that introduce interference that can degrade performance and/or a capacity associated with wireless communication between wireless communication sites and UEs. For example, the interference may worsen a quality of telecommunication services provided by the wireless communication sites to the UEs, such as at least one of cellular service (e.g., 5G service, 4G service and/or other type of cellular service), internet service (e.g., cellular internet service, satellite internet service, 5G internet service, and/or other type of internet service), messaging service, etc. In response to identifying an interference source, corrective action may be taken to mitigate the interference source to improve network performance of one or more wireless communication sites.

[0045] In some examples, the communication device **1502** and/or the antenna **802** may be used to detect and/or identify interference sources by traveling with the communication

device **1502** and/or the antenna **802** and/or monitoring an outputs of the communication device **1502** across different locations. In an example, the antenna **802** and/or the communication device **1502** may be in a motor vehicle (e.g., a car) that is used to transport the antenna **802** and/or the communication device **1502** across the different locations, wherein the antenna **802** may be mounted (e.g., placed) on an object in the motor vehicle (e.g., a dashboard of the motor vehicle) using the mounting apparatus **1402** (e.g., the tripod). Alternatively and/or additionally, the antenna **802** may be carried by hand (e.g., the tripod may be configured to convert into a handle that can be conveniently carried by hand by a person tasked with transporting the antenna **802**). An interference source may be detected and/or identified based upon an output of the communication device **1502** (e.g., the output may be indicative of one or more radio metrics, such as at least one of one or more EMI metrics, one or more EMC metrics, etc.). In response to detecting and/or identifying the interference source, one or more corrective actions may be performed. For example, the one or more corrective actions may be performed to mitigate the interference source. For example, the one or more corrective actions may comprise checking, deactivating and/or replacing equipment (e.g., equipment determined to be the interference source) to mitigate and/or prevent interference of the interference source. Alternatively and/or additionally, the one or more corrective actions may comprise modifying one or more settings and/or parameters of equipment (e.g., equipment determined to be the interference source) to mitigate and/or prevent interference of the interference source.

[0046] In some examples, the antenna **802** may comprise a log-periodic antenna, such as a log-periodic dipole array (LPDA). In some examples, the antenna **802** may be a broadband measurement antenna, wherein the broadband. In some examples, the antenna **802** may have a frequency range from about 700 megahertz (MHz) to about 2.5 gigahertz (GHz) (or other frequency range). For example, the antenna may be used for mobile measurement and/or direction finding applications. Alternatively and/or additionally, the antenna may be configured for EMI measurement and/or EMC measurement. In some examples, the antenna **802** comprises a directional antenna. In some examples, the antenna **802** may be used as a directional-antenna for at least one of WLAN, WiFi and/or one or more other directional communication applications. In some examples, the antenna **802** may have alignable (e.g., freely alignable) polarization).

[0047] According to some embodiments, a protective structure, to protect an antenna from damage, is provided. The protective structure includes a body. The body defines one or more prong-receiving apertures in a first surface of the body, wherein each prong of one or more prongs of the antenna extends at least partially through an aperture of the one or more prong-receiving apertures. The body defines a radio frequency (RF) connection aperture extending from the first surface of the body to a second surface of the body. The antenna includes an RF connector. A cable extends at least partially through the RF connection aperture. A cable connector of the cable is coupled to the RF connector.

[0048] According to some embodiments, a first prong-receiving aperture of the one or more prong-receiving apertures is defined by a plurality of inner sidewalls of the body; and one or more inner sidewalls, of the plurality of inner

sidewalls of the body, are in contact with a prong, of the one or more prongs, extending through the first prong-receiving aperture.

[0049] According to some embodiments, the one or more inner sidewalls inhibit displacement of the protective structure relative to the antenna.

[0050] According to some embodiments, the one or more prong-receiving apertures include a first prong-receiving aperture and a second prong-receiving aperture; and the RF connection aperture is between the first prong-receiving aperture and the second prong-receiving aperture.

[0051] According to some embodiments, a direction of extension of the one or more prong-receiving apertures is parallel to a direction of extension of the RF connection aperture.

[0052] According to some embodiments, the protective structure includes a tongue over a surface of the antenna, wherein a mounting apparatus is attached to the antenna via an aperture in the tongue.

[0053] According to some embodiments, the mounting apparatus includes a tripod.

[0054] According to some embodiments, the antenna includes a broadband measurement antenna.

[0055] According to some embodiments, a first shape of a first prong-receiving aperture of the one or more prong-receiving apertures matches a second shape of a prong, of the one or more prongs, extending through the first prong-receiving aperture.

[0056] According to some embodiments, the first shape and the second shape are rectangular.

[0057] According to some embodiments, the body defines one or more fastener-receiving apertures in a third surface of the body, wherein the body is configured to receive a fastener through the one or more fastener-receiving apertures to provide strain relief to the cable and/or the RF connector.

[0058] According to some embodiments, the third surface is parallel to a direction of extension of the RF connection aperture.

[0059] According to some embodiments, the fastener includes a cable tie.

[0060] According to some embodiments, a protective structure, to protect an antenna from damage, is provided. The protective structure includes a body. The body defines one or more prong-receiving apertures in a first surface of the body, wherein through each aperture of the one or more prong-receiving apertures, the body is configured to receive a prong of one or more prongs of the antenna. The body defines a radio frequency (RF) connection aperture extending from the first surface of the body to a second surface of the body, wherein the body is configured to receive a cable through the RF connection aperture to couple a cable connector of the cable to an RF connector of the antenna.

[0061] According to some embodiments, the one or more prong-receiving apertures include a first prong-receiving aperture and a second prong-receiving aperture; and the RF connection aperture is between the first prong-receiving aperture and the second prong-receiving aperture.

[0062] According to some embodiments, a direction of extension of the one or more prong-receiving apertures is parallel to a direction of extension of the RF connection aperture.

[0063] According to some embodiments, the protective structure includes a tongue attached to the body, wherein the

tongue defines an antenna attachment aperture; and the tongue is configured to receive a fastener through the antenna attachment aperture to attach a mounting apparatus and the protective structure to the antenna.

[0064] According to some embodiments, the mounting apparatus includes a tripod.

[0065] According to some embodiments, the body defines one or more fastener-receiving apertures in a third surface of the body; the body is configured to receive a fastener through the one or more fastener-receiving apertures to provide strain relief to the cable and/or the RF connector; the third surface of the body is opposite a fourth surface of the body to which the tongue is attached; and a direction of extension of the RF connection aperture is parallel to the third surface and/or the fourth surface.

[0066] According to some embodiments, a protective structure, to protect an antenna from damage, is provided. The protective structure includes a body. The body defines one or more prong-receiving apertures in a first surface of the body, wherein each prong of one or more prongs of the antenna extends at least partially through an aperture of the one or more prong-receiving apertures. The body defines a radio frequency (RF) connection aperture extending from the first surface of the body to a second surface of the body. The antenna includes an RF connector. At least a portion of the RF connector is within the RF connection aperture and/or a cable extends at least partially through the RF connection aperture. A cable connector of the cable is coupled to the RF connector.

[0067] Unless specified otherwise, “first,” “second,” and/or the like are not intended to imply a temporal aspect, a spatial aspect, an ordering, etc. Rather, such terms are merely used as identifiers, names, etc. for features, elements, items, etc. For example, a first object and a second object generally correspond to object A and object B or two different or two identical objects or the same object.

[0068] Moreover, “example” is used herein to mean serving as an example, instance, illustration, etc., and not necessarily as advantageous. As used herein, “or” is intended to mean an inclusive “or” rather than an exclusive “or”. In addition, “a” and “an” as used in this application are generally be construed to mean “one or more” unless specified otherwise or clear from context to be directed to a singular form. Also, at least one of A and B and/or the like generally means A or B or both A and B. Furthermore, to the extent that “includes”, “having”, “has”, “with”, and/or variants thereof are used in either the detailed description or the claims, such terms are intended to be inclusive in a manner similar to the term “comprising”.

[0069] Although the subject matter has been described in language specific to structural features and/or methodological acts, it is to be understood that the subject matter defined in the appended claims is not necessarily limited to the specific features or acts described above. Rather, the specific features and acts described above are disclosed as example forms of implementing at least some of the claims.

[0070] Also, although the disclosure has been shown and described with respect to one or more implementations, alterations and modifications may be made thereto and additional embodiments may be implemented based upon a reading and understanding of this specification and the annexed drawings. The disclosure includes all such modifications, alterations and additional embodiments and is limited only by the scope of the following claims. The

specification and drawings are accordingly to be regarded in an illustrative rather than restrictive sense. In particular regard to the various functions performed by the above described components (e.g., elements, resources, etc.), the terms used to describe such components are intended to correspond, unless otherwise indicated, to any component which performs the specified function of the described component (e.g., that is functionally equivalent), even though not structurally equivalent to the disclosed structure. In addition, while a particular feature of the disclosure may have been disclosed with respect to only one of several implementations, such feature may be combined with one or more other features of the other implementations as may be desired and advantageous for any given or particular application.

What is claimed is:

1. A protective structure to protect an antenna from damage, comprising:
 - a body defining:
 - one or more prong-receiving apertures in a first surface of the body, wherein each prong of one or more prongs of the antenna extends at least partially through an aperture of the one or more prong-receiving apertures; and
 - a radio frequency (RF) connection aperture extending from the first surface of the body to a second surface of the body, wherein:
 - the antenna comprises an RF connector;
 - a cable extends at least partially through the RF connection aperture; and
 - a cable connector of the cable is coupled to the RF connector.
2. The protective structure of claim 1, wherein:
 - a first prong-receiving aperture of the one or more prong-receiving apertures is defined by a plurality of inner sidewalls of the body; and
 - one or more inner sidewalls, of the plurality of inner sidewalls of the body, are in contact with a prong, of the one or more prongs, extending through the first prong-receiving aperture.
3. The protective structure of claim 2, wherein:
 - the one or more inner sidewalls inhibit displacement of the protective structure relative to the antenna.
4. The protective structure of claim 1, wherein:
 - the one or more prong-receiving apertures comprise a first prong-receiving aperture and a second prong-receiving aperture; and
 - the RF connection aperture is between the first prong-receiving aperture and the second prong-receiving aperture.
5. The protective structure of claim 4, wherein:
 - a direction of extension of the one or more prong-receiving apertures is parallel to a direction of extension of the RF connection aperture.
6. The protective structure of claim 1, comprising:
 - a tongue over a surface of the antenna, wherein a mounting apparatus is attached to the antenna via an aperture in the tongue.
7. The protective structure of claim 6, wherein:
 - the mounting apparatus comprises a tripod.
8. The protective structure of claim 7, wherein:
 - the antenna comprises a broadband measurement antenna.

9. The protective structure of claim 1, wherein:
a first shape of a first prong-receiving aperture of the one or more prong-receiving apertures matches a second shape of a prong, of the one or more prongs, extending through the first prong-receiving aperture.
10. The protective structure of claim 9, wherein:
the first shape and the second shape are rectangular.
11. The protective structure of claim 1, wherein:
the body defines one or more fastener-receiving apertures in a third surface of the body, wherein the body is configured to receive a fastener through the one or more fastener-receiving apertures to provide strain relief to at least one of the cable or the RF connector.
12. The protective structure of claim 11, wherein:
the third surface is parallel to a direction of extension of the RF connection aperture.
13. The protective structure of claim 11, wherein:
the fastener comprises a cable tie.
14. A protective structure to protect an antenna from damage, comprising:
a body defining:
one or more prong-receiving apertures in a first surface of the body, wherein through each aperture of the one or more prong-receiving apertures, the body is configured to receive a prong of one or more prongs of the antenna; and
a radio frequency (RF) connection aperture extending from the first surface of the body to a second surface of the body, wherein the body is configured to receive a cable through the RF connection aperture to couple a cable connector of the cable to an RF connector of the antenna.
15. The protective structure of claim 14, wherein:
the one or more prong-receiving apertures comprise a first prong-receiving aperture and a second prong-receiving aperture; and
the RF connection aperture is between the first prong-receiving aperture and the second prong-receiving aperture.
16. The protective structure of claim 15, wherein:
a direction of extension of the one or more prong-receiving apertures is parallel to a direction of extension of the RF connection aperture.
17. The protective structure of claim 14, comprising:
a tongue attached to the body, wherein:
the tongue defines an antenna attachment aperture; and
the tongue is configured to receive a fastener through the antenna attachment aperture to attach a mounting apparatus and the protective structure to the antenna.
18. The protective structure of claim 17, wherein:
the mounting apparatus comprises a tripod.
19. The protective structure of claim 17, wherein:
the body defines one or more fastener-receiving apertures in a third surface of the body;
the body is configured to receive a fastener through the one or more fastener-receiving apertures to provide strain relief to at least one of the cable or the RF connector;
the third surface of the body is opposite a fourth surface of the body to which the tongue is attached; and
a direction of extension of the RF connection aperture is parallel to at least one of the third surface or the fourth surface.
20. A protective structure to protect an antenna from damage, comprising:
a body defining:
one or more prong-receiving apertures in a first surface of the body, wherein each prong of one or more prongs of the antenna extends at least partially through an aperture of the one or more prong-receiving apertures; and
a radio frequency (RF) connection aperture extending from the first surface of the body to a second surface of the body, wherein:
the antenna comprises an RF connector;
at least one of:
at least a portion of the RF connector is within the RF connection aperture; or
a cable extends at least partially through the RF connection aperture; and
a cable connector of the cable is coupled to the RF connector.

* * * * *