



US006817633B2

(12) **United States Patent**
Brill et al.

(10) **Patent No.:** **US 6,817,633 B2**
(45) **Date of Patent:** **Nov. 16, 2004**

(54) **TUBULAR MEMBERS AND THREADED CONNECTIONS FOR CASING DRILLING AND METHOD**

(75) Inventors: **Leland M. Brill**, Hughes Spring, TX (US); **Bluford W. Lowery**, Linden, TX (US); **Edmond L. Miller**, Bowie County, TX (US)

(73) Assignee: **Lone Star Steel Company**, Dallas, TX (US)

(*) Notice: Subject to any disclaimer, the term of this patent is extended or adjusted under 35 U.S.C. 154(b) by 24 days.

(21) Appl. No.: **10/325,050**

(22) Filed: **Dec. 20, 2002**

(65) **Prior Publication Data**

US 2004/0118569 A1 Jun. 24, 2004

(51) **Int. Cl.**⁷ **F16L 35/00**

(52) **U.S. Cl.** **285/333; 285/390; 285/148.19**

(58) **Field of Search** 285/148.19, 333, 285/334, 390, 355

(56) **References Cited**

U.S. PATENT DOCUMENTS

196,904 A	*	11/1877	Ingersoll	285/148.13
964,353 A	*	7/1910	Whittier	285/148.1
1,134,092 A	*	4/1915	Bahr	285/32
1,731,171 A	*	10/1929	Perkins	285/123.1
1,947,909 A	*	2/1934	Hollander	138/44
RE19,196 E	*	6/1934	Hinderliter	285/106
2,122,757 A	*	7/1938	Scott	285/334

2,150,221 A	*	3/1939	Hinderliter	285/332.3
2,205,697 A	*	6/1940	Scharpenberg	285/237
2,211,173 A		8/1940	Shaffer	285/146
2,812,025 A		11/1957	Teague et al.	166/207
3,397,745 A		8/1968	Owens et al.	166/57
3,463,228 A		8/1969	Hearn	166/181
3,489,437 A		1/1970	Duret	285/55
3,508,771 A		4/1970	Duret	285/334

(List continued on next page.)

FOREIGN PATENT DOCUMENTS

WO 99/18328 4/1999 E21B/23/01

OTHER PUBLICATIONS

American Petroleum Institute's, "Specification for Threading, Gauging, and Thread Inspection of Casing, Tubing, and Line Pipe Threads (U.S. Customary Units)," API Specification Standard 5B, Fourteenth Edition, 30 pages, 8/96.

(List continued on next page.)

Primary Examiner—Eric K. Nicholson

(74) *Attorney, Agent, or Firm*—Baker Botts L.L.P.

(57) **ABSTRACT**

Oil country tubular goods and other types of tubular members are provided with threaded and coupled connections satisfactory for use in drilling and completing wellbores. The threaded and coupled connections are used to join sections of casing with each other to form a casing string which may be used to drill and complete a wellbore. Each tubular member has first and second pin ends with approximately the same thread form and thread profile with different pitch diameters. Standard API couplings may be used with the casing string.

22 Claims, 3 Drawing Sheets

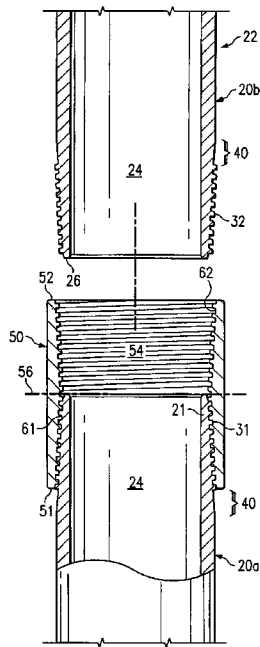

U.S. PATENT DOCUMENTS

3,567,254 A	*	3/1971	Parssinen	403/307
3,572,777 A		3/1971	Blose et al.	285/334
3,574,357 A		4/1971	Trigoviste et al.	285/47
3,581,817 A		6/1971	Kammerer, Jr.	166/208
3,678,727 A		7/1972	Jackson	72/367
3,826,124 A		7/1974	Baksay	72/367
3,830,294 A		8/1974	Swanson, Jr.	166/51
3,830,295 A		8/1974	Crowe	166/125
3,874,446 A		4/1975	Crowe	166/129
3,915,763 A		10/1975	Jennings et al.	148/127
3,963,076 A		6/1976	Winslow	166/278
4,018,634 A		4/1977	Fencl	148/131
4,397,484 A		8/1983	Miller	285/81
4,445,265 A	*	5/1984	Olson et al.	29/447
4,458,925 A		7/1984	Raulins et al.	285/332.2
4,483,399 A		11/1984	Colgate	166/308
4,495,073 A		1/1985	Beimgraben	210/448
4,508,167 A		4/1985	Weinberg et al.	166/120
4,531,552 A		7/1985	Kim	138/149
4,538,442 A		9/1985	Reed	72/367
4,582,348 A		4/1986	Dearden et al.	285/175
4,603,889 A		8/1986	Welsh	285/175
4,676,563 A		6/1987	Curlett et al.	439/194
4,762,344 A		8/1988	Perkins et al.	285/175
4,799,544 A		1/1989	Curlett	166/65.1
4,825,674 A		5/1989	Tanaka et al.	72/98
4,836,278 A		6/1989	Stone et al.	166/115
4,838,349 A		6/1989	Berzin	166/187
4,846,508 A	*	7/1989	Pallini, Jr.	285/148.19
4,921,045 A		5/1990	Richardson	166/134
4,924,949 A		5/1990	Curlett	175/25
5,048,871 A		9/1991	Pfeiffer et al.	285/39
5,174,340 A		12/1992	Peterson et al.	138/110
5,249,628 A		10/1993	Surjaatmadia	166/308
RE34,467 E		12/1993	Reeves	285/334
5,348,095 A		9/1994	Worrall et al.	166/380
5,360,239 A	*	11/1994	Klementich	285/94
5,361,836 A		11/1994	Sorem et al.	166/187
5,366,012 A		11/1994	Lohbeck	166/277
5,388,648 A		2/1995	Jordan, Jr.	166/380
5,667,011 A		9/1997	Gill et al.	166/295
5,901,789 A		5/1999	Donnelly et al.	166/381
5,933,945 A		8/1999	Thomeer et al.	29/825
5,964,288 A		10/1999	Leighton et al.	166/207
5,984,568 A		11/1999	Lohbeck	403/375
6,012,522 A		1/2000	Donnelly et al.	166/276

6,024,181 A		2/2000	Richardson et al.	175/162
6,070,671 A		6/2000	Cumming et al.	166/381
6,253,846 B1		7/2001	Nazzai et al.	166/242.2
6,253,850 B1		7/2001	Nazzai et al.	166/277
6,263,966 B1		7/2001	Haut et al.	166/278
6,263,968 B1		7/2001	Freeman et al.	166/313
6,263,972 B1		7/2001	Richard et al.	166/381
6,273,634 B1		8/2001	Lohbeck	403/297
6,286,558 B1		9/2001	Quigley et al.	138/125
6,311,792 B1		11/2001	Scott et al.	175/162
6,315,040 B1		11/2001	Donnelly	166/207
6,318,457 B1		11/2001	Den Boer et al.	166/66.7
6,328,113 B1		12/2001	Cook	166/387
6,334,351 B1		1/2002	Tsuchiya	72/370.06
6,443,247 B1		9/2002	Wardley	175/402
6,447,025 B1		9/2002	Smith	285/333
6,454,024 B1		9/2002	Nackerud	175/57

OTHER PUBLICATIONS

- Joe Haberer's "New Solutions May Ease Hardbanding Controversy," *Drilling Contractor*, 2 pages, Sep./Oct. 2000.
- Joe Haberer's "Viable Drill Pipe Hardbanding Strategies are Outlined," *Drilling Contractor*, 2 pages, Nov./Dec. 2000.
- Rigzone's, "Tesco Provides Casing Drilling Operations Update" at internet address http://www.rigzone.com/news/article.asp?a_id=1755, 2 pages, Oct. 16, 2001.
- Rigzone's, "Conoco and Tesco Unveil Revolutionary Drilling Rig" at internet address http://www.rigzone.com/news/article.asp?a_id=2603, 2 pages, Feb.11, 2002.
- Tesco Corporation's, "Casing Drilling™ Process" at internet address http://www.tescocorp.com/htmls/casing_drilling.html, 4 pages, Sep. 30, 2002.
- Rick von Flatern, "Olified Service Trio Target Jules Verne Territory," at internet address <http://www.oilonline.com/new/features/oe/20010817.oilfield.7127.asp>, 9 pages, Aug. 17, 2001.
- Ian D. Harris', "Tube Welding," at internet address <http://www.tubenet.org.uk/technical/ewi.html>, 6 pages, Dec. 9, 2002.
- KSBEAR Premium Connection, JFE Steel Corporation at Internet, 8 pages <http://www.life-steel.co.Ip/en/products/pipes/octg/pdf/KSBear.odf>.

* cited by examiner

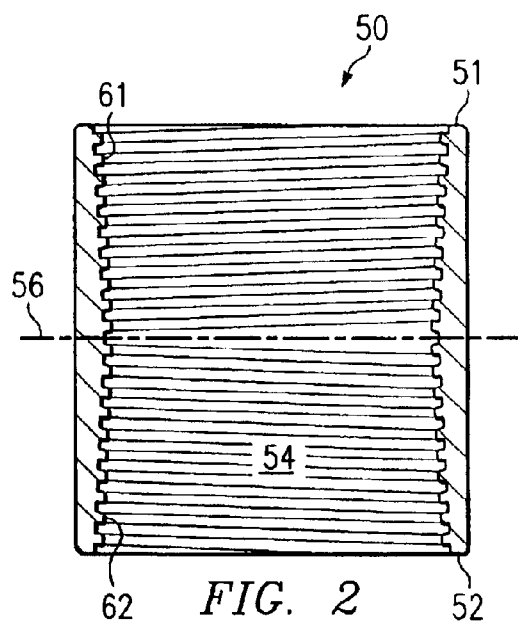
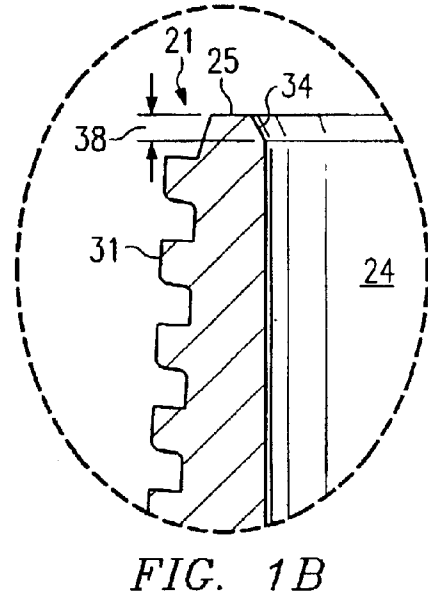
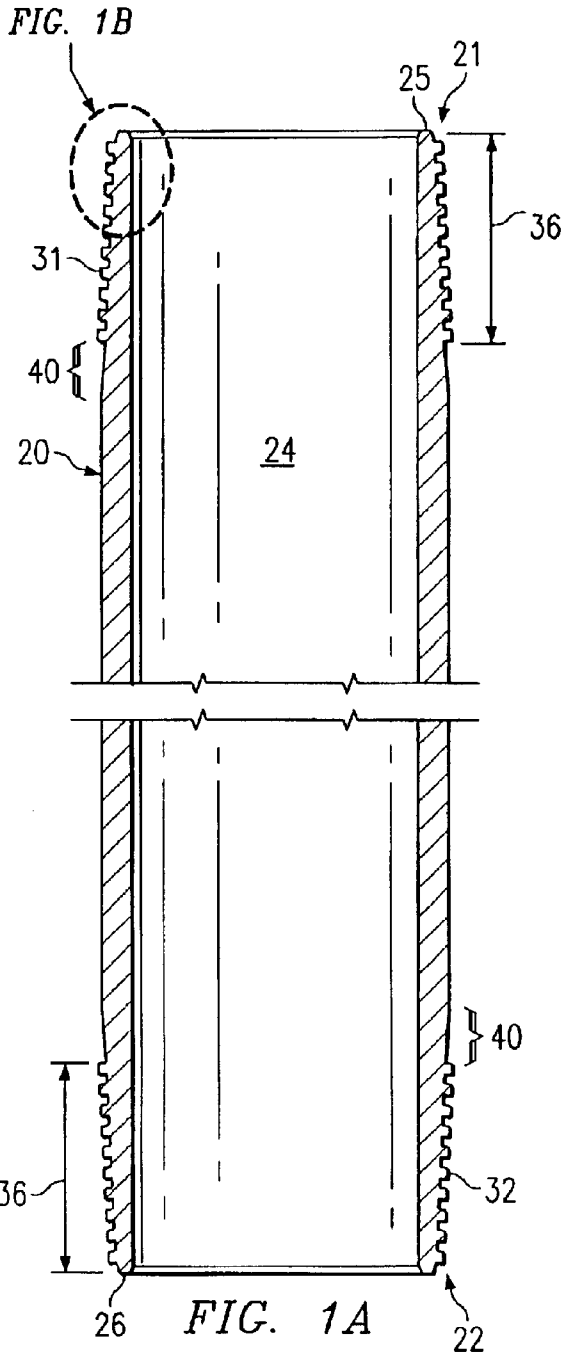

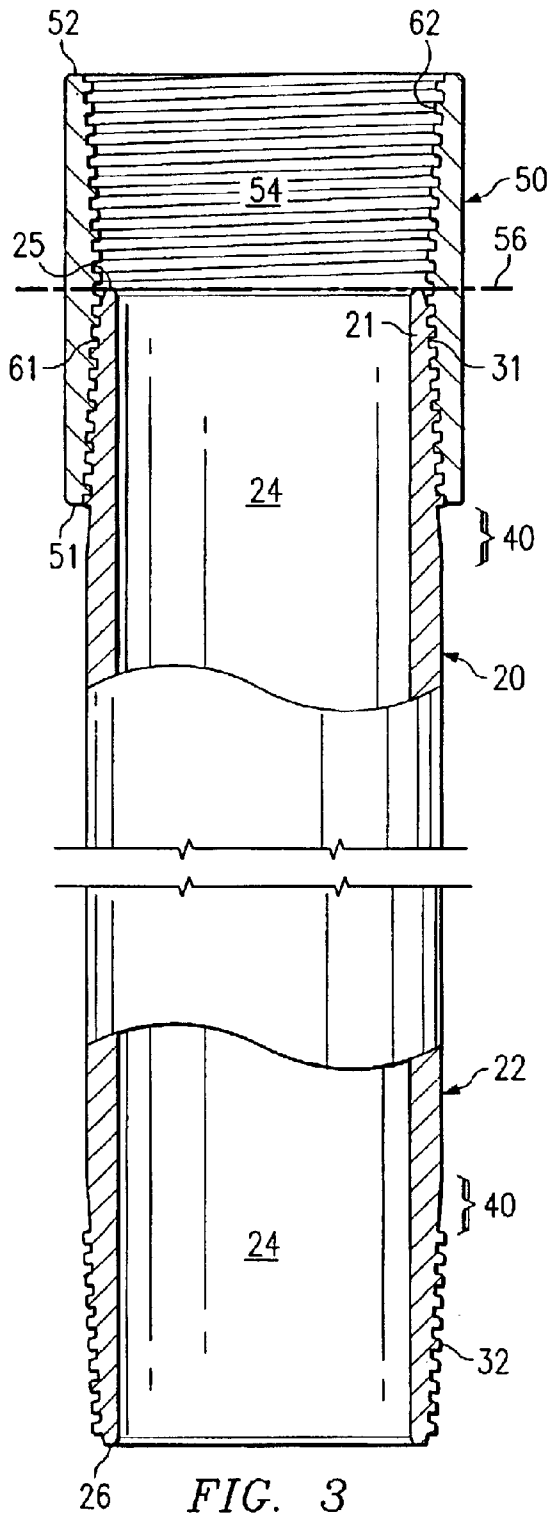

FIG. 3

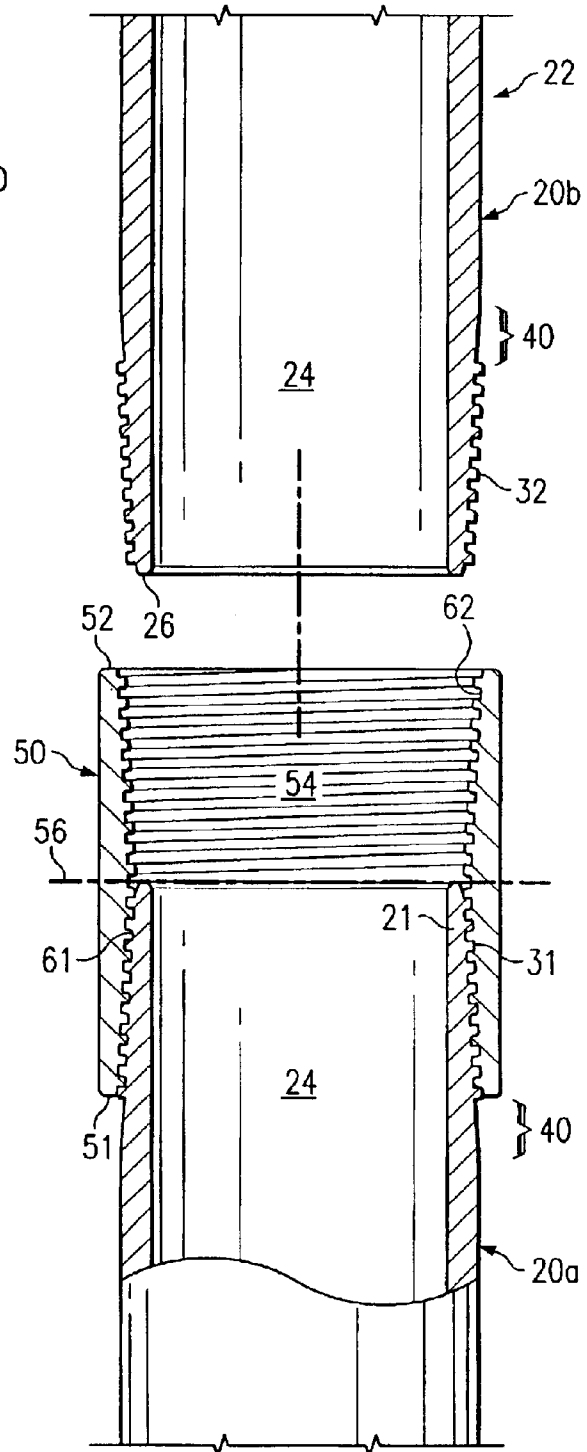
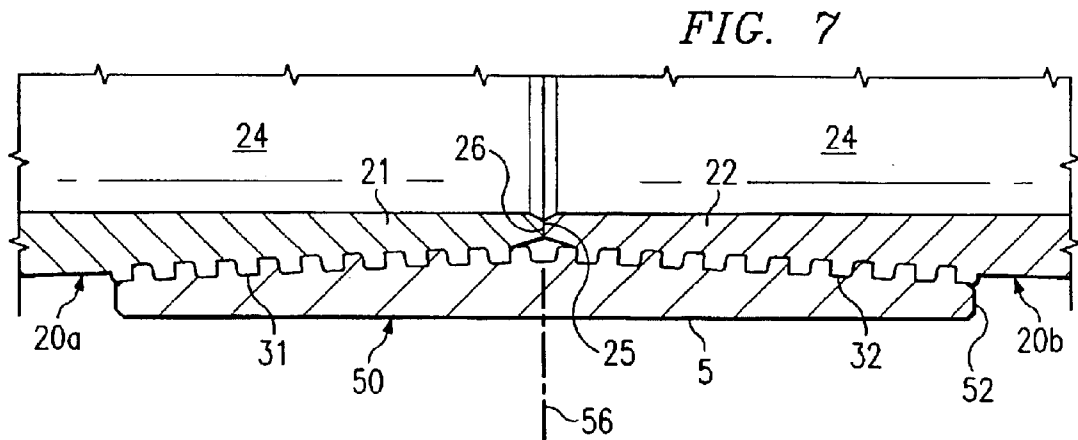
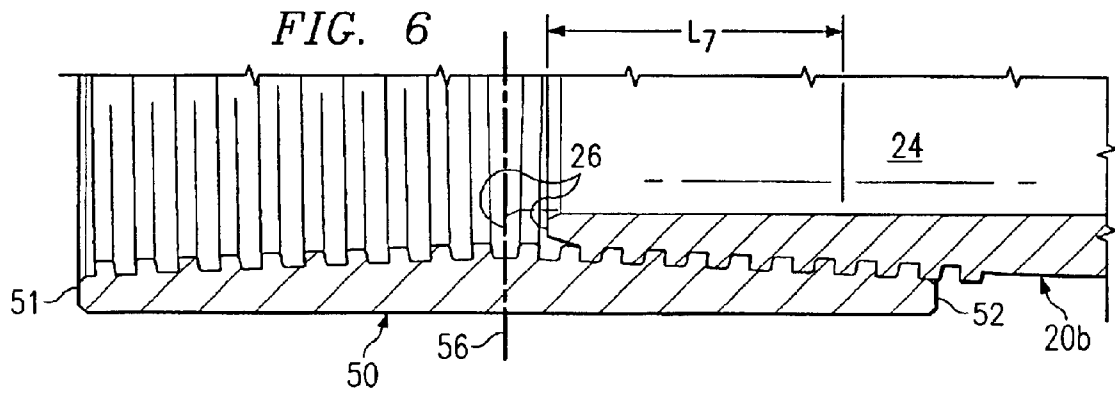
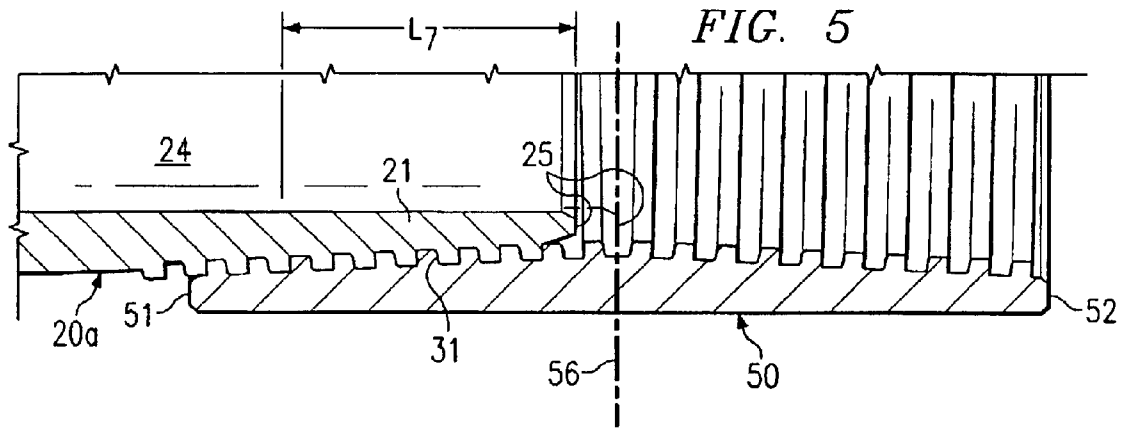

FIG. 4



TUBULAR MEMBERS AND THREADED CONNECTIONS FOR CASING DRILLING AND METHOD

TECHNICAL FIELD

The present invention is related to apparatus and methods to drill and complete oil and gas wells. More particularly, the present invention is related to using a casing string to both drill a wellbore and complete the wellbore.

BACKGROUND OF THE INVENTION

Oil and gas wells and other types of wells such as geothermal wells are typically drilled from the well surface to a desired downhole location using a rotary drilling rig, drill pipe, and drill bits. Various types of bottom hole assemblies may also be used as required by associated geological formations. After a wellbore has been drilled to a desired depth or downhole location, one or more casing strings may then be installed extending from the well surface to the desired downhole location. A cement sheath or cement bond is typically formed between the outside diameter of each casing string and adjacent inside diameters of the wellbore. Many wells have two or more casing strings with different inside diameters installed in a telescoping manner from the well surface to a desired downhole location. For example, a first casing string may be installed from the well surface to a depth of 500 to 1,000 feet. The first casing string may have an outside diameter of nine and five-eighths inches (9 $\frac{5}{8}$ "'). A second casing string may be installed extending from proximate the downhole end of the first casing string to a desired depth of 9,000 or 10,000 feet. The second casing string may have an outside diameter of approximately seven inches (7"').

Wellbores for producing oil, gas or other formation fluids from selected subsurface formations, are typically drilled in stages. For example, a wellbore may be first drilled with a drill string and a first drill bit having particular diameter. At a desired depth for a first portion of the wellbore, the drill string and drill bit are removed from the wellbore. Tubular members of smaller diameter, often referred to as casing or a casing string, may then be placed in the first portion of the wellbore. An annulus formed between the inside diameter of the wellbore and the outside diameter of the casing string is generally filled with cement. The cement provides support for the casing and isolates downhole formations or subterranean strata from each other. Often, the next step in drilling the wellbore is to pass the drill string with a second, smaller diameter drill bit through the first casing string and drill another portion of the wellbore to a selected depth beyond the depth of the first casing string. This sequence of drilling wellbores and installing casing strings may be repeated as many times as necessary, with smaller and smaller components until the ultimate desired depth or downhole location of the wellbore has been achieved.

The cost of drilling and completing wellbores, particularly in offshore regions, is extremely expensive. Typical operating costs for an offshore drilling rig may easily exceed \$100,000 per day. Thus, there are substantial benefits to minimizing the length of time required to drill a wellbore. At extended distances from the well surface (15,000 feet or greater) round trip time required to pull a drill bit and replace it with another drill bit may be several hours. The associated trip time is often non-productive and wasteful.

For very deep wells or very long wells (20,000 feet or greater), there may be three or four changes in casing

diameter from the well surface to the total depth or desired downhole location of the wellbore. Each change in diameter of the casing string results in a corresponding decrease in the diameter of production tubing used to produce formation fluids from selected downhole formations. The change in casing diameter associated with typical deep wells and/or long wells results in significantly increased drilling and completion costs.

During the past several years an increasing number of oil and gas wells have been drilled using standard oilfield casing rather than drill pipe. Standard oilfield casing generally has less wall thickness when compared with standard drill pipe. Drill bits and other downhole tools used to drill wells have been modified to allow installation and removal from downhole locations through a casing string using wireline techniques. For example, drill bits may be inserted through the longitudinal bore of a casing string and releasably latched adjacent to and extending from the end of to the last joint of a casing string using wireline techniques. Such drill bits may also be removed from the end of the casing string using similar wireline techniques when the wellbore has been drilled to a desired downhole location. The casing string may then be cemented within the wellbore to form a portion of the well completion system.

Drilling a wellbore with a casing string eliminates or substantially reduces the number of times which pipe must be removed and inserted (tripped) from the wellbore. Drilling a well using a casing string generally reduces drilling costs and completion costs as compared with drilling a well with conventional drill pipe and using conventional completion techniques to install a casing string in the resulting wellbore.

SUMMARY OF THE INVENTION

In accordance with teachings of the present invention, threaded connections are provided for use on casing and other tubular goods used for drilling and completing wellbores. One aspect of the present invention includes providing tubular goods with threaded and coupled connections which may be used to releasably engage the tubular goods with each other to allow drilling a wellbore and completion the wellbore.

Technical benefits of the present invention include providing a casing string with threaded and coupled connections that enhance use of the casing string to drill a wellbore and complete the wellbore without removing or tripping the casing string. The threaded and coupled connection may be substantially stronger and more rugged than conventional threaded connections used on oilfield casing. A threaded connection formed in accordance with teachings of the present invention provides mechanical strength required to drill a wellbore and provides fluid, pressure tight seals between the interior and the exterior of the casing string. Since the wall thickness of a casing string is generally less than the wall thickness of conventional drill pipe, threaded and coupled connections formed in accordance with teachings of the present invention provided desired mechanical strength in threaded portions where the wall thickness is often reduced as compared with other portions of the casing string.

Further technical benefits of the present invention include providing one or more mechanical surfaces on the exterior of a casing string to accommodate applying hardfacing to selected portions of the casing string. Hardfacing selected portions of a casing string may be desired when the casing string is used to drill a wellbore.

BRIEF DESCRIPTION OF THE DRAWINGS

A more complete and thorough understanding of the present embodiments and advantages thereof may be acquired by referring to the following description taken in conjunction with the accompanying drawings, in which like reference numbers indicate like features, and wherein:

FIG. 1A is a schematic drawing in section with portions broken away of a tubular member having a first pin end and a second pin end with respective thread profiles formed in accordance with teachings of the present invention;

FIG. 1B is an enlarged schematic drawing in section with portions broken away showing a chamfer formed on the first pin end of the tubular member of FIG. 1A;

FIG. 2 is a schematic drawing in section with portions broken away of a coupling having a first box end and a second box end with respective thread profiles formed in accordance with teachings of the present invention;

FIG. 3 is a schematic drawing in section with portions broken away of a tubular member and a coupling releasably engaged with each other in accordance with teachings of the present invention;

FIG. 4 is a schematic drawing in section with portions broken away showing a first tubular member and a coupling releasably engaged with each other in accordance with teachings of the present invention and a second tubular member by a having a threaded pin end formed in accordance with teachings of the present invention;

FIG. 5 is a schematic drawing in section with portions broken away showing the mill end of a tubular member and an attached coupling incorporating teachings of the present invention;

FIG. 6 is a schematic drawing in section with portions broken away showing the field end of a tubular member and an attached coupling incorporating teachings of the present invention between; and

FIG. 7 is a schematic drawing in section with portions broken away showing the mill end of a first tubular member, the field end of a second tubular member and a coupling having threaded connections incorporating teachings of the present invention.

DETAILED DESCRIPTION OF THE INVENTION

Preferred embodiments of the invention and its advantages are best understood by reference to FIGS. 1A-7 wherein like numbers refer to same and like parts.

The term "oil country tubular goods" and "OCTG" are used in this application to include casing, tubing, pup joints, couplings and any other type of pipe or tubular member associated with drilling, producing or servicing oil wells, natural gas wells, geothermal wells or any other subsurface wellbore.

The terms "welded pipe" and "welded tubular goods" are used in this application to include any pipe or tubular member manufactured from rolled steel or steel strips or steel strips which passed through forming rollers to create a longitudinal butt joint and was welded along the longitudinal butt joint. The resulting longitudinal butt weld or longitudinal seam weld may be formed using various techniques such as electric resistance welding (ERW), arc welding, laser welding, high frequency induction welding and other techniques satisfactory for producing longitudinal seam welds. Welded pipe and welded tubular members may be produced in individual links or may be produced in con-

tinuous links from coiled skelp and subsequently cut into individual links.

Various aspects of the present invention will be described with respect to tubular members which have been formed using electric resistant welding (ERW) technology. However, the present invention is not limited to use with tubular members produced by ERW technology. A wide variety of tubular members and oil country tubular goods (OCTG) may be releasably engaged with each other by threaded connections formed in accordance with teachings of the present invention.

Various aspects of the present invention will be described with respect to tubular members **20** and couplings **50** as shown in FIGS. 1A-7. To describe some features of the present invention, tubular members **20** may sometimes be designated as **20a** and **20b**. For some applications, tubular members **20** may be sections of a casing string used to both drill and complete a wellbore (not expressly shown). For such applications, each tubular member **20** may have substantially the same overall dimensions and configurations as associated with a conventional oil field casing string. For other applications, one or more tubular members (not expressly shown) with dimensions and configurations associated with a bottom hole assembly (not expressly shown) used to drill oil and gas wells may have threaded portions corresponding with tubular members **20**. Also, one or more tubular members **20** may have a configuration and dimensions associated with liner hangers (not expressly shown) or other components used to complete oil and gas wells.

FIG. 1 shows tubular member **20** which may be formed using electric resistance welding (ERW) technology. For this embodiment, tubular member **20** may be generally described as an elongated, hollow section of casing. Tubular member **20** includes first end **21** and second end **22** with longitudinal bore **24** extending therethrough. Respective thread profiles **31** and **32** incorporating teachings of the present invention are preferably formed on respective first end **21** and second end **22** of tubular member **20**. First end **21** and second end **22** may sometimes be referred to as "pin ends". As discussed later in more detail, portions of first thread profile **31** and second thread profile **32** may generally correspond with standard American Petroleum Institute (API) buttress threads for oil country tubular goods. API Specification Standard **5B** contains detailed information for casing threads.

First end or pin end **21** of tubular member **20** may be described as the "mill end". Second end or pin end **22** may be described as the "field end". The relationship between mill end **21**, field end **22** and coupling **50** are shown in more detail in FIGS. 5, 6 and 7. Various features associated with external thread profiles **31** and **32** will be described with respect to center plane **56** of associated coupling **50**.

Coupling **50**, as shown in FIG. 2, may have the same overall dimensions and configuration associated with standard API couplings for oil country tubular goods. Coupling **50** may be described as a relatively short section of pipe defined in part by first end **51** and second end **52** with longitudinal bore **54** extending therebetween. Matching internal thread profiles **61** and **62** may be formed within longitudinal bore **54** extending respectively from first end **51** and second end **52**. Center plane **56** defines approximately the middle of coupling **50** where internal thread profiles **61** and **62** meet. For some applications, thread profiles **61** and **62** may be standard API buttress threads for oil country tubular goods as described in API Specification Standard **5B**. Imperfect thread areas associated with forming internal

thread profiles **61** and **62** of coupling **50** are controlled to ensure that there is no interference with any imperfect threads during make up of field end **22** with a mill end **21** of respective tubular members **20** within longitudinal bore **54**.

Tubular member **20** with coupling **50** attached thereto in accordance with the teachings of the present invention is shown in FIG. 3. For some applications, tubular member **20** may be initially formed with blank ends (not expressly shown). Respective thread profiles **31** and **32** may then be formed on first pin end **21** and second pin end **22** using conventional pipe threading machines and equipment (not expressly shown). During the manufacturing process associated with forming thread profiles **31** and **32**, coupling **50** may be releasably engaged with first pin end **21**. Tubular member **20** will then be shipped from the manufacturing facility with coupling **50** releasably engaged with first pin end **21**. Therefore, first pin end **21** with coupling **50** attached thereto may sometimes be referred to as the "factory end."

Various types of powered tools and equipment (not expressly shown) may be satisfactorily used to releasably engage coupling **50** with first thread profile **31** of pin end **21**. As previously noted, coupling **50** preferably has matching internal thread profiles **61** and **62**. Therefore, either first end **51** or second end **52** of coupling **50** may be releasably engaged with first pin end **21**. For purposes of describing various features of the present invention, the process of making up or releasably engaging coupling **50** with first pin end **21** will be described with respect to end **51**. In a similar manner, releasable engagement of second pin end **22** with coupling **50** will be described with respect to second end **52**. However, first pin end **21** may be satisfactorily engaged with second end **52** of coupling **50** and second pin end **22** may be satisfactorily engaged with first end **51** of coupling **50**.

FIG. 4 shows a typical orientation of first tubular member **20a** and second tubular member **20b** prior to making up the tubular members on a drilling platform (not expressly shown). The present invention allows multiple tubular members **20** to be releasably engaged with each other to form a casing string for drilling and completing a wellbore (not expressly shown). Generally, first tubular member **20a** will be positioned by the drilling platform over a wellbore with second end or box end **52** looking up to receive second pin end or field end **22** of second tubular member **20b**. Various types of pipe tongs and other equipment associated with making and breaking treaded connections between oil country tubular goods may be satisfactorily used to releasably engage second pin end **22** of second tubular member **20b** with second end or box end **52** of coupling **50**. Various details associated with releasably engaging second pin end **22** of second tubular member **20b** with coupling **50** and first tubular member **20a** will be discussed later in more detail.

For the embodiments of the present invention as shown in FIGS. 1A–7, thread profiles **31** and **32** may be generally described as modified API buttress threads having standard API buttress thread forms associated with oil field casing. However, thread profiles **31** and **32** formed in accordance with teachings of the present invention preferably include several significant differences as compared with corresponding API buttress threads. For example, length **36** of each thread profile **31** and **32** is preferably selected to be longer than the length of a corresponding standard API buttress thread having approximately the same overall dimensions and configuration. Length **36** for thread profile **31** is measured from extreme end **25** of first pin end **21** to a plane extending normal to longitudinal bore **24** the last vanishing thread of thread profile **31**. Length **36** of thread profile **32** is measured from extreme end **26** to a plane extending normal

to longitudinal bore **24** at the last vanishing thread of thread profile **32**. See FIG. 1A.

For casing threads formed in accordance with API Specification Standard **5B** this same length is often defined as dimension " L_4 ". Length **36** of respective thread profiles **31** and **32** is preferably selected such that extreme end **25** of first pin end **21** will abut extreme end **26** of second pin end **22** when respective thread profiles **31** and **32** are engaged with coupling **50**. See FIGS. 5, 6 and 7.

Casing threads and casing connections as defined in API specification standard **5B** may be made up to a "basic hand-tight position" and to a "basic power-tight position" as indicated by markings on the exterior of the casing sections and couplings. The hand tight position for factory end or first pin end **21** relative to coupling **50** is shown by solid lines in FIG. 5. The power tight position for factory end or first pin end **21** relative to coupling **50** is shown by dotted lines in FIG. 5. The hand tight position for field end or second pin end **22** relative to coupling **50** is shown by solid lines in FIG. 6. The power tight position for field end or second pin end **22** relative to coupling **50** is shown by dotted lines in FIG. 6.

A threaded and coupled connection formed in accordance with teachings of the present invention preferably has a power-tight position defined in part by the extreme end of the field end of one tubular member directly contacting the extreme end of the mill end of another tubular member at approximately the mid-point or center plane of an associated coupling. The power-tight position for releasably engaging tubular members **20a**, **20b** and coupling **50** with each other is shown in FIG. 7.

Extreme end **26** of field end **22** of second tubular member **20b** and extreme end **25** of mill end **21** of first tubular member **20a** are in direct contact with each other at center plane **56** of coupling **50**. This contact between extreme ends **25** and **26** creates adjoining or abutting radial torque shoulders located proximate center plane **56** of coupling **50**. Direct contact between extreme ends **25** and **26** ensures that all torsional forces exerted during rotary drilling of a wellbore will be transmitted against adjacent tubular members **20a** and **20b** and not against the adjacent threads and/or coupling **50**. Table 1 provides representative values of dimension L_4 (length **36**) for mill ends and pin ends of tubular members with threaded connections formed in accordance with teachings of the present invention.

As shown in FIGS. 1A and 1B, respective chamfered surfaces **34** are preferably formed within longitudinal bore **24** at first end **21** and second end **22**. For some applications chamfered surfaces **34** may extend at an angle of approximately sixty five degrees (65°) between the inside diameter of longitudinal bore **24** and respective extreme ends **25** and **26**. Length **38** of each chamfered surface **34** is preferably limited to a maximum value of approximately one-quarter of an inch ($\frac{1}{4}$ ") to maintain substantial bearing surfaces or bearing faces at respective extreme ends **25** and **26**. As a result of increasing length **36** of thread profiles **31** and **32** and limiting length **38** of chamfered surfaces **34**, a relatively wide, sturdy torque bearing surfaces are provided at the contact between adjacent field ends and mill ends of tubular members **20**.

Frequently, the inside diameter at the pin ends of oil country tubular goods having API threads are reamed to ensure that the inside diameter adjacent to the associated thread profiles meets designed limitations. When thread profiles **31** and **32** are formed on respective mill end **21** and field ends **22** of tubular members **20**, the inside diameter of

longitudinal bore 24 is only deburred. Eliminating standard reaming steps associated with API casing threads helps maintain desired bearing surfaces at extreme ends 25 and 26.

As previously noted, external thread profiles 31 and 32 may be generally described as modified API buttress casing threads. Conventional API buttress casing threads have a specified length for the "perfect threads" which varies depending upon the size or nominal outside diameter of the associated casing. Also, API buttress threads have a required pitch diameter which varies based on the size or nominal outside diameter of the associated casing. The specified length for the perfect threads is frequently referred to as dimension L₇.

The perfect thread length (dimension L₇) at the specified thread diameter for thread profiles 31 and 32 are preferably mismatched. See TABLE 1. For the embodiment of the present invention as shown in FIGS. 5 and 6, the pitch diameter of thread profile 31 formed on mill end 21 may be approximately 0.006 inch larger than the pitch diameter of the thread profile 32 formed on field end 22. The difference in pitch diameters will typically result in a higher pressure during power make up of coupling 50 with mill end 21 as compared with the power make up of coupling 50 with field end 22. As a result of the pressure difference during power make up, a threaded and coupled connection such as shown in FIG. 7 will not rotate or turn during make up of field end 22 with box end 52 of coupling 50.

TABLE 1

EXAMPLES OF SOME TYPICAL THREAD DIMENSIONS FOR EXTERNAL THREAD PROFILES 31 AND 32							
MILL END PIN							
Size Outside Diameter	Major Diameter D ₄	No. of Threads Per Inch	Taper Per Foot Cone	Length of Imperfect Threads	Length of Perfect Threads L ₇	Total Length of Threads L ₄ (36)	End of Pipe to Center of Coupling Hand Tight
4 1/2	4.516	5	0.750	1.9840	1.8535	3.8375	0.600
7	7.016	5	0.750	1.9840	2.416	4.4000	0.600
9 5/8	9.641	5	0.750	1.9840	2.7285	4.7125	0.600
13 3/8	13.391	5	0.750	1.9840	2.7285	4.7125	0.600

FIELD END PIN							
Size Outside Diameter	Maximum Length of Chamfer	Length End of Pipe to Triangle Stamp A ₁	Length Face of Coupling to Min.	Coupling Length Min.	Diameter of Counter Bore Coupling	Maximum Length of Imperfect Threads in Center of Coupling J Area	End of Pipe to Center of Coupling Power Tight Make up
4 1/2	0.250	4.437	1.884	8.875	4.640	0.250	
7	0.250	5.000	1.784	10	7.140	0.250	
9 5/8	0.250	5.3125	1.784	10.625	9.765	0.250	
13 3/8	0.250	5.3125	1.784	10.625	13.515	0.250	

Size Outside Diameter	Length of Imperfect Threads L ₇	Length of Perfect Threads L ₄ (36)	End of Pipe to Center of Coupling Hand Tight	Pitch Diameter at Length of Perfect Threads L ₇ (E7)	End of Pipe to Center of Coupling Power Tight Make up
4 1/2	0.250	4.437	1.884	8.875	4.640
7	0.250	5.000	1.784	10	7.140
9 5/8	0.250	5.3125	1.784	10.625	9.765
13 3/8	0.250	5.3125	1.784	10.625	13.515

TABLE 1-continued

EXAMPLES OF SOME TYPICAL THREAD DIMENSIONS FOR EXTERNAL THREAD PROFILES 31 AND 32							
Size Outside Diameter	Maximum Length of Chamfer	Length End of Pipe to Triangle Stamp A ₁	Length Face of Coupling to plane (E7)	Coupling Length Min.	Diameter of Counter Bore Coupling	Maximum Length of Imperfect Threads in Center of Coupling J Area	
4 1/2	0.250	4.437	1.884	8.875	4.640	0.250	0.000
7	0.250	5.000	1.784	10	7.140	0.250	0.000
9 5/8	0.250	5.3125	1.784	10.625	9.765	0.250	0.000
13 3/8	0.250	5.3125	1.784	10.625	13.515	0.250	0.000

Hardbanding is often applied to selected portions of conventional drill strings to reduce abrasive wear and resulting outside diameter reduction of associated tool joints and bottom hole assembly components. Hardbanding is often applied to preserve and extend the life of drill pipe, collars, and heavyweight components of a drill string. Hardbanding may be reapplied when previous applications or components experience excessive wear. Both research and field experience have demonstrated that applying tungsten carbide based hardbanding to tool joints and other components will reduce drill string wear.

During the past several years, oil and gas wells have routinely been drilled to much greater depths and/or longer lengths than was considered normal or typical when hardbanding was first developed for drill strings. Also, wellbore geometries have become much more complex including highly deviated, horizontal, multilateral, short-radius and extended reach wellbores. As a result of producing oil and gas reservoirs from deeper downhole locations and more remotely located geological formations, the number of rotating hours required to drill associated wellbores has substantially increased. Conventional hardbanding on drill strings may contribute to reduction of the wall thickness of casing strings, risers and other tubular members associated with drilling and completion of wellbores. In some cases, the reduction in wall thickness may result in forming holes which allow undesired fluid communication through damaged casing, risers or other well completion complements. As a result, new hardbanding materials and methods for applying hardbanding to various components of a drill string have been developed to substantially reduce or eliminate damage to casing, risers and other well completion components while at the same time providing desired protection for drill string components.

For some applications a slightly reduced outside diameter portion or machined portion 40 may be formed on first pin end 21 and second pin end 22 extending longitudinally from the last thread or vanishing thread of respective thread profiles 31 and 32. Reduced outside diameter portion 40 may be machined by a thread cutting tool (not expressly shown) for a selected longitudinal distance along the outside diameter of tubular member 20. For some applications reduced outside diameter portion 40 having a length of approximately one and one half inches (1 1/2") may be formed on first end or mill end 21 of tubular member 20. A generally cylindrical, hollow sleeve or applique (not expressly shown) having substantially the same diameter as reduced outside

diameter portion **40** may be disposed on the outside diameter portion **40** of tubular member **20**. Engagement of coupling **50** with mill end **21** will result in trapping the sleeve or applique between the extreme end **51** or **52** of coupling **50** and the normal outside diameter portion of tubular member **20**.

One or more layers of hardfacing material may be disposed on the sleeve. For some applications the sleeve may have a length of approximately one and one half inches (1½") which corresponds generally with the length of reduced outside diameter portion **40**. The hardfacing material formed on the exterior of the sleeve may have a length of approximately one inch (1"). For some applications hardfacing sleeves may only be installed on a limited number of threaded and coupled connections such as the bottom five or six sections of casing or tubular members **20** used to drill and complete a wellbore.

Although the present invention and its advantages have been described in detail, it should be understood that various changes, substitutions and alternations can be made herein without departing from the spirit and scope of the invention as defined by the following claims.

What is claimed is:

1. A threaded connection for releasably coupling tubular members with each other, comprising:

a coupling having a first box end and a second box end with a longitudinal bore extending through the coupling from the first box end to the second box end;

a first internal thread profile formed within the first box end of the coupling;

a second internal thread profile formed within the second box end of the coupling;

each tubular member having a respective first pin end and a respective second pin end;

a longitudinal bore extending through each tubular member from the respective first end to the respective second end;

a first external thread profile formed on the first pin end and a second external thread profile formed on the second pin end;

the first external thread profile having a pitch diameter larger than a pitch diameter of the second external thread profile; and

the pitch diameter of the first external thread profile approximately 0.006 inches larger than the pitch diameter of the second external thread profile.

2. A threaded connection for releasably coupling tubular members with each other, comprising:

a coupling having a first box end and a second box end with a longitudinal bore extending through the coupling from the first box end to the second box end;

a first internal thread profile formed within the first box end of the coupling;

a second internal thread profile formed within the second box end of the coupling;

each tubular member having a respective first pin end and a respective second pin end;

a longitudinal bore extending through each tubular member from the respective first end to the respective second end;

a first external thread profile formed on the first pin end and a second external thread profile formed on the second pin end;

the first external thread profile having a pitch diameter larger than a pitch diameter of the second external thread profile;

the coupling having a center plane disposed proximate the middle of the coupling and the associated longitudinal bore;

the first internal thread profile of the coupling having a first length extending through the longitudinal bore of the coupling from a first extreme end of the coupling to the center plane;

the second internal thread profile of the coupling having a second length extending through the longitudinal bore of the coupling from a second extreme end to coupling to the center plane;

the first length of the first internal thread profile approximately equal to the second length of the second internal thread profile;

the first external thread profile having a length extending from an extreme end of the first pin end to a plane corresponding with the last thread of the first external thread profile;

the length of the first external thread profile approximately equal to the first length of the first internal thread profile;

the second external thread profile having a length extending from an extreme end of the second pin end to a plane corresponding with the last thread of the second thread profile; and

the length of the second external thread profile approximately equal with the second length of the second internal thread profile.

3. A threaded connection for releasably coupling tubular members with each other, comprising:

a coupling having a first box end and a second box end with a longitudinal bore extending through the coupling from the first box end to the second box end;

a first internal thread profile formed within the first box end of the coupling;

a second internal thread profile formed within the second box end of the coupling;

each tubular member having a respective first pin end and a respective second pin end;

a longitudinal bore extending through each tubular member from the respective first end to the respective second end;

a first external thread profile formed on the first pin end and a second external thread profile formed on the second pin end;

the first external thread profile having a pitch diameter larger than a pitch diameter of the second external thread profile;

the extreme end of the first pin end of one tubular member directly abutting the extreme end of the second pin end of another tubular member proximate the center plane of the coupling; and

contact of the first pin end with the second pin end directly transmitting torsional forces exerted on the one tubular member during drilling of a wellbore to the other tubular member.

4. A threaded connection for releasably coupling tubular members with each other, comprising:

a coupling having a first box end and a second box end with a longitudinal bore extending through the coupling from the first box end to the second box end;

a first internal thread profile formed within the first box end of the coupling;

a second internal thread profile formed within the second box end of the coupling;

11

each tubular member having a respective first pin end and a respective second pin end;

a longitudinal bore extending through each tubular member from the respective first end to the respective second end;

a first external thread profile formed on the first pin end and a second external thread profile formed on the second pin end;

the first external thread profile having a pitch diameter larger than a pitch diameter of the second external thread profile; and

the first internal thread profile and the second internal thread profile having matching API buttress thread forms.

5. A threaded connection for releasably coupling tubular members with each other, comprising:

a coupling having a first box end and a second box end with a longitudinal bore extending through the coupling from the first box end to the second box end;

a first internal thread profile formed within the first box end of the coupling;

a second internal thread profile formed within the second box end of the coupling;

each tubular member having a respective first pin end and a respective second pin end;

a longitudinal bore extending through each tubular member from the respective first end to the respective second end;

a first external thread profile formed on the first pin end and a second external thread profile formed on the second pin end;

the first external thread profile having a pitch diameter larger than a pitch diameter of the second external thread profile; and

the first external thread profile and the second external thread profile having matching API buttress thread forms.

6. A threaded connection for releasably coupling tubular members with each other, comprising:

a coupling having a first box end and a second box end with a longitudinal bore extending through the coupling from the first box end to the second box end;

a first internal thread profile formed within the first box end of the coupling;

a second internal thread profile formed within the second box end of the coupling;

each tubular member having a respective first pin end and a respective second pin end;

a longitudinal bore extending through each tubular member from the respective first end to the respective second end;

a first external thread profile formed on the first pin end and a second external thread profile formed on the second pin end;

the first external thread profile having a pitch diameter larger than a pitch diameter of the second external thread profile;

a first chamfer formed on the first pin end between the first thread of the first external thread profile and the extreme end of the first pin end;

a second chamfer formed on the second pin end between the first thread of the second external thread profile and the extreme end of the second pin end;

12

the first chamfer and the second chamfer having approximately equal lengths; and

the length of the first chamfer and the second chamfer limited to a maximum value of one fourth of an inch.

7. A threaded connection formed between a first tubular member, a second tubular member and a coupling comprising:

the coupling having a first box end and second box end with a longitudinal bore extending through the coupling from the first box end to the second box end;

a first internal thread profile formed within the first box end of the coupling and extending to a center plane of the coupling;

a second internal thread profile formed within the second box end of the coupling and extending to the center plane;

the first tubular member having a first pin end and a second pin end;

the second tubular member having a first pin end and a second pin end;

the first tubular member and the second tubular member having respective longitudinal bores extending there-through;

a first external thread profile formed on each first pin end and a second external thread profile formed on each second pin end;

the first external thread profile having a pitch diameter larger than a corresponding pitch diameter larger than a corresponding pitch diameter of the second external thread profile; and

the larger pitch diameter of the first external thread profile resulting in higher fluid pressure during power make up of each first pin end with one of the box ends of the coupling as compared with power make up of each second pin end with the other box end of the coupling.

8. The threaded connection of claim 7 further comprising the pitch diameter of the first external thread profile approximately 0.006 inches larger than the pitch diameter of the second external thread profile.

9. The threaded connection of claim 7 further comprising:

the coupling having a center plane disposed proximate the middle of the coupling and its associated longitudinal bore;

each first external thread profile having a length extending from an extreme end of the first pin end to a plane corresponding with the last thread of the first thread profile; and

the length of each first external thread profile approximately equal with the length of the longitudinal bore of coupling measured from an extreme end of the coupling to the center plane.

10. The threaded connection of claim 7 further comprising:

the coupling having a center plane disposed at approximately the middle of the coupling and its associated longitudinal bore;

the first external thread profile having a length extending from the extreme end of the first end to a plane corresponding with the last thread of the first thread profile; and

the length of the first external thread profile approximately equal with a length of the longitudinal bore measured from an extreme end of the coupling to the center plane.

13

11. The threaded connection of claim 7 further comprising:

the first internal thread profile and the second internal thread profile having matching API buttress thread forms; and

the first external thread profile and the second external thread profile having API buttress thread forms matching the thread forms of the first internal thread profile and the second internal thread profile.

12. A section of casing for using in drilling and completing a wellbore comprising:

a first end and a second end with a respective pin formed on the first end and a respective pin formed on the second end;

a longitudinal bore extending through the section of casing between the first end and the second end;

a first external thread profile formed on the first end and a second external thread profile formed on the second end;

a coupling having a first box end and a second box end with a longitudinal bore extending through the coupling from the first box end to the second box end;

a first internal thread profile formed within the first box end of the coupling;

a second internal thread profile formed within the second box end of the coupling;

the first external thread profile having a pitch diameter larger than a pitch diameter of the second external profile;

the first external thread profile releasably engaged with one of the internal thread profiles of the coupling;

at least one reduced outside diameter portion formed on the section of casing extending from one of the external thread profiles; and

the reduced outside diameter portion comprises a length of one and one half inches.

13. A section of casing for using in drilling and completing a wellbore comprising:

a first end and a second end with a respective pin formed on the first end and a respective pin formed on the second end;

a longitudinal bore extending through the section of casing between the first end and the second end;

a first external thread profile formed on the first end and a second external thread profile formed on the second end;

a coupling having a first box end and a second box end with a longitudinal bore extending through the coupling from the first box end to the second box end;

a first internal thread profile formed within the first box end of the coupling;

a second internal thread profile formed within the second box end of the coupling;

the first external thread profile having a pitch diameter larger than a pitch diameter of the second external profile;

the first external thread profile releasably engaged with one of the internal thread profiles of the coupling;

the first external thread profile having a length extending from an extreme end of the first pin end to a plane corresponding with the last thread of the first thread profile;

the length of the first external thread profile approximately equal to one half the length of the longitudinal bore of the coupling;

14

the second external thread profile having a length extending from an extreme end of the second pin end to a plane corresponding with the last thread of the second thread profile; and

the length of the second thread profile approximately equal with one half of the length of the longitudinal bore of the coupling.

14. A section of casing for using in drilling and completing a wellbore comprising:

a first end and a second end with a respective pin formed on the first end and a respective pin formed on the second end;

a longitudinal bore extending through the section of casing between the first end and the second end;

a first external thread profile formed on the first end and a second external thread profile formed on the second end;

a coupling having a first box end and a second box end with a longitudinal bore extending through the coupling from the first box end to the second box end;

a first internal thread profile formed within the first box end of the coupling;

a second internal thread profile formed within the second box end of the coupling;

the first external thread profile having a pitch diameter larger than a pitch diameter of the second external profile;

the first external thread profile releasably engaged with one of the internal thread profiles of the coupling;

a first chamfer formed on the first pin end and a second chamfer formed on the second pin end;

the first chamfer extending between the extreme end of the first pin end and an inside diameter of the longitudinal bore;

the second chamfer extending between the extreme end of the second pin end and an inside diameter of the longitudinal bore;

the first chamfer having a length approximately equal to a length of the second chamfer; and

the length of the first chamfer and the length of the second chamfer approximately equal to or less than one fourth of an inch.

15. A section of casing for using in drilling and completing a wellbore comprising:

a first end and a second end with a respective pin formed on the first end and a respective pin formed on the second end;

a longitudinal bore extending through the section of casing between the first end and the second end;

a first external thread profile formed on the first end and a second external thread profile formed on the second end;

a coupling having a first box end and a second box end with a longitudinal bore extending through the coupling from the first box end to the second box end;

a first internal thread profile formed within the first box end of the coupling;

a second internal thread profile formed within the second box end of the coupling;

the first external thread profile having a pitch diameter larger than a pitch diameter of the second external profile;

the first external thread profile releasably engaged with one of the internal thread profiles of the coupling; and

15

the first internal thread profile of the coupling and the second internal thread profile of the coupling having approximately equal pitch diameters.

16. A method of forming a section of casing for use in drilling a wellbore, comprising:

forming a first, elongated tubular member having a first pin end and a second pin end with a longitudinal bore extending through the tubular member from the first pin end to the second pin end;

forming a first tapered exterior thread profile with a first pitch diameter on the first pin end of the tubular member;

forming a second exterior tapered thread profile with a second pitch diameter on the second pin end of the first tubular member;

forming the first pitch diameter larger than the second pitch diameter;

forming a coupling having a first end and a second end with a longitudinal bore through the coupling from the first end to the second end;

forming a third tapered thread profile within the longitudinal bore of the coupling extending from the first end to proximate a mid point in the longitudinal bore of the coupling;

forming a fourth tapered thread profile within the longitudinal bore of the coupling extending from the second end to proximate a mid point of the longitudinal bore of the coupling;

releasably engaging the first pin end of the first, elongated tubular member with one of the thread profiles of the coupling; and

forming the first pitch diameter approximately 0.006 inches larger than the second pitch diameter.

17. The method of claim 16 further comprising forming the first, elongated tubular member using electric resistance welding techniques.

18. The method of claim 16 further comprising forming a reduced outside diameter on the first pin end extending from the last thread of the first tapered external thread profile.

19. A method of forming a section of casing for use in drilling a wellbore, comprising:

forming a first, elongated tubular member having a first pin end and a second pin end with a longitudinal bore extending through the tubular member from the first pin end to the second pin end;

forming a first tapered exterior thread profile with a first pitch diameter on the first pin end of the tubular member;

forming a second exterior tapered thread profile with a second pitch diameter on the second pin end of the first tubular member;

forming the first pitch diameter larger than the second pitch diameter;

forming a coupling having a first end and a second end with a longitudinal bore through the coupling from the first end to the second end;

forming a third tapered thread profile within the longitudinal bore of the coupling extending from the first end to proximate a mid point in the longitudinal bore of the coupling;

forming a fourth tapered thread profile within the longitudinal bore of the coupling extending from the second end to proximate a mid point of the longitudinal bore of the coupling;

16

releasably engaging the first pin end of the first, elongated tubular member with one of the thread profiles of the coupling; and

forming the reduced outside diameter portion with a length of approximately one and one half inches extending longitudinally from the last thread of the first tapered external thread profile.

20. A method of forming a section of casing for use in drilling a wellbore, comprising:

forming a first, elongated tubular member having a first pin end and a second pin end with a longitudinal bore extending through the tubular member from the first pin end to the second pin end;

forming a first tapered exterior thread profile with a first pitch diameter on the first pin end of the tubular member;

forming a second exterior tapered thread profile with a second pitch diameter on the second pin end of the first tubular member;

forming the first pitch diameter larger than the second pitch diameter;

forming a coupling having a first end and a second end with a longitudinal bore through the coupling from the first end to the second end;

forming a third tapered thread profile within the longitudinal bore of the coupling extending from the first end to proximate a mid point in the longitudinal bore of the coupling;

forming a fourth tapered thread profile within the longitudinal bore of the coupling extending from the second end to proximate a mid point of the longitudinal bore of the coupling;

releasably engaging the first pin end of the first, elongated tubular member with one of the thread profiles of the coupling; and

forming the first tapered external thread profile and the second tapered external thread profile with matching API thread forms.

21. A method of forming a section of casing for use in drilling a wellbore, comprising:

forming a first, elongated tubular member having a first pin end and a second pin end with a longitudinal bore extending through the tubular member from the first pin end to the second pin end;

forming a first tapered exterior thread profile with a first pitch diameter on the first pin end of the tubular member;

forming a second exterior tapered thread profile with a second pitch diameter on the second pin end of the first tubular member;

forming the first pitch diameter larger than the second pitch diameter;

forming a coupling having a first end and a second end with a longitudinal bore through the coupling from the first end to the second end;

forming a third tapered thread profile within the longitudinal bore of the coupling extending from the first end to proximate a mid point in the longitudinal bore of the coupling;

forming a fourth tapered thread profile within the longitudinal bore of the coupling extending from the second end to proximate a mid point of the longitudinal bore of the coupling;

releasably engaging the first pin end of the first, elongated tubular member with one of the thread profiles of the coupling;

17

forming a chamfer on the first pin end having a length equal to or less than one fourth of an inch; and

forming a chamfer on the second pin end having a length approximately equal to or less than one fourth of an inch or less.

22. A method of forming a section of casing for use in drilling a wellbore, comprising:

forming a first, elongated tubular member having a first pin end and a second pin end with a longitudinal bore extending through the tubular member from the first pin end to the second pin end;

forming a first tapered exterior thread profile with a first pitch diameter on the first pin end of the tubular member;

forming a second exterior tapered thread profile with a second pitch diameter on the second pin end of the first tubular member;

forming the first pitch diameter larger than the second pitch diameter;

forming a coupling having a first end and a second end with a longitudinal bore through the coupling from the first end to the second end;

18

forming a third tapered thread profile within the longitudinal bore of the coupling extending from the first end to proximate a mid point in the longitudinal bore of the coupling;

forming a fourth tapered thread profile within the longitudinal bore of the coupling extending from the second end to proximate a mid point of the longitudinal bore of the coupling;

forming a second, elongated tubular member having a respective first pin end, second pin end, longitudinal bore, first tapered exterior thread profile and second tapered exterior thread profile corresponding generally with the first, elongated tubular member;

releasably engaging the second pin end of the second tubular with the other thread profile of the coupling; and

making up the first pin of the first tubular member with the coupling as compared with the fluid pressure required to make up the second pin end of the second tubular member with the coupling.

* * * * *