



US 20200189314A1

(19) **United States**

(12) **Patent Application Publication**
Zehnder et al.

(10) **Pub. No.: US 2020/0189314 A1**

(43) **Pub. Date: Jun. 18, 2020**

(54) **SINGLE PIECE HEAVY DUTY WHEEL**

(71) Applicant: **Arconic Inc.**, Pittsburgh, PA (US)

(72) Inventors: **Craig M. Zehnder**, Akron, OH (US);
Gabriele F. Ciccola, Hudson, OH (US);
Grant DeGeorge, Strongsville, OH (US);
Santosh Prasad, Murrysville, PA (US);
Henry Sklyut, Delmont, PA (US);
Anton Rovito, Parma, OH (US);
Christopher J. Tan, Broadview Heights, OH (US);
Jay H. Goodman, Murrysville, PA (US)

(21) Appl. No.: **16/801,246**

(22) Filed: **Feb. 26, 2020**

Related U.S. Application Data

(63) Continuation of application No. PCT/US18/50609, filed on Sep. 12, 2018.

(60) Provisional application No. 62/561,462, filed on Sep. 21, 2017.

Publication Classification

(51) **Int. Cl.**
B60B 21/10 (2006.01)

(52) **U.S. Cl.**
CPC **B60B 21/104** (2013.01); **B60B 2310/208** (2013.01); **B60B 2310/202** (2013.01)

(57) **ABSTRACT**

A wheel rim including a flange profile on a tire side of an open end flange of the wheel rim, the flange profile defined by the equation:

$$y_1 = \left(a_{\Theta 1} + \frac{1}{(1 + \text{Exp}(a_{\Theta 3} + a_{\Theta 4} \cdot X_1))^{a_{\Theta 5}}} \right) \cdot a_{\Theta 2}$$

wherein, for $0 \leq X_1 \leq 1$, $a_{\Theta 1}$ is between -1.004 to -0.974 , $a_{\Theta 2}$ is between -1.049 to -1.0182 , $a_{\Theta 3}$ is between -3.601 to -2.760 , $a_{\Theta 4}$ is between 18.791 to 25.965 , and $a_{\Theta 5}$ is between 0.185 to 0.277 .

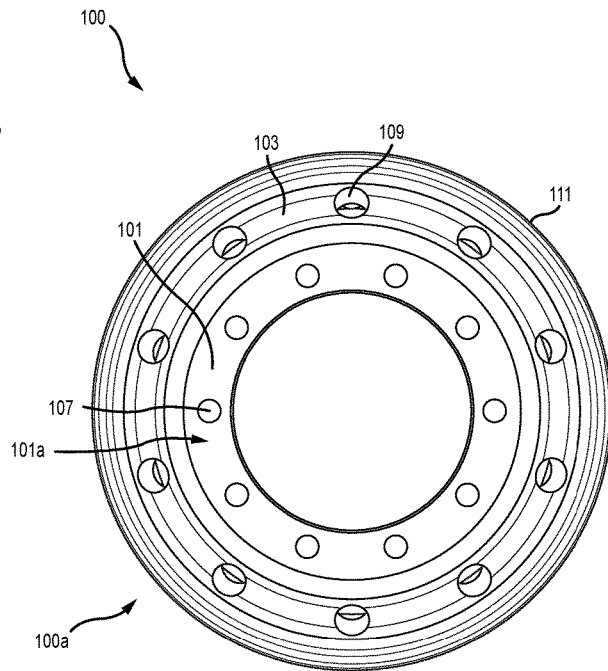
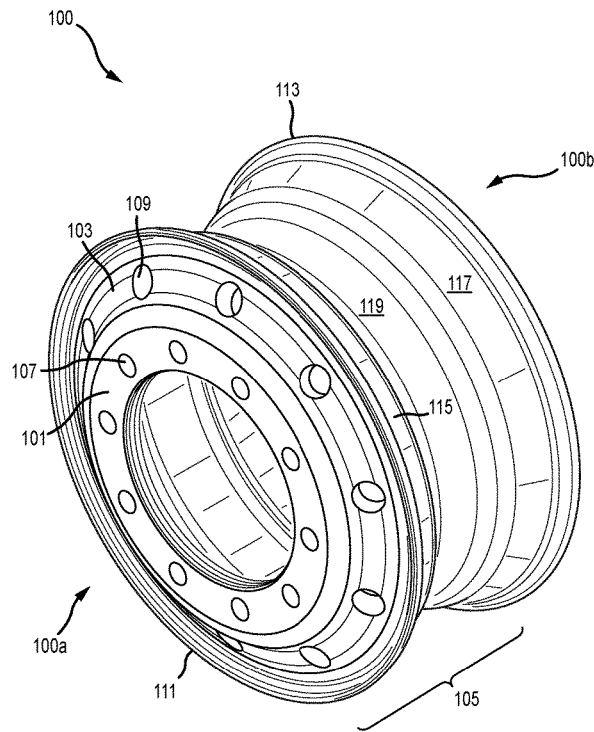

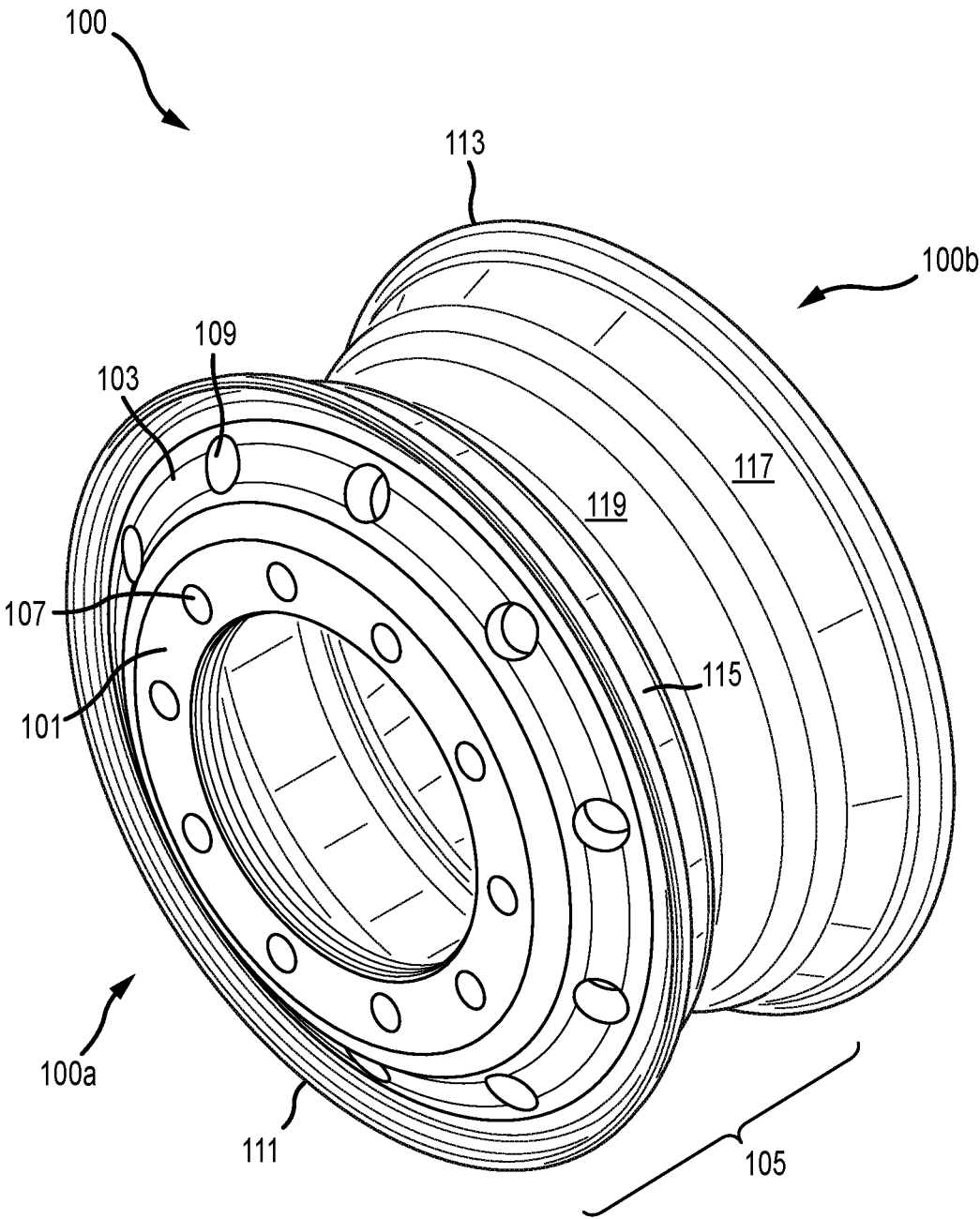

FIG.1A

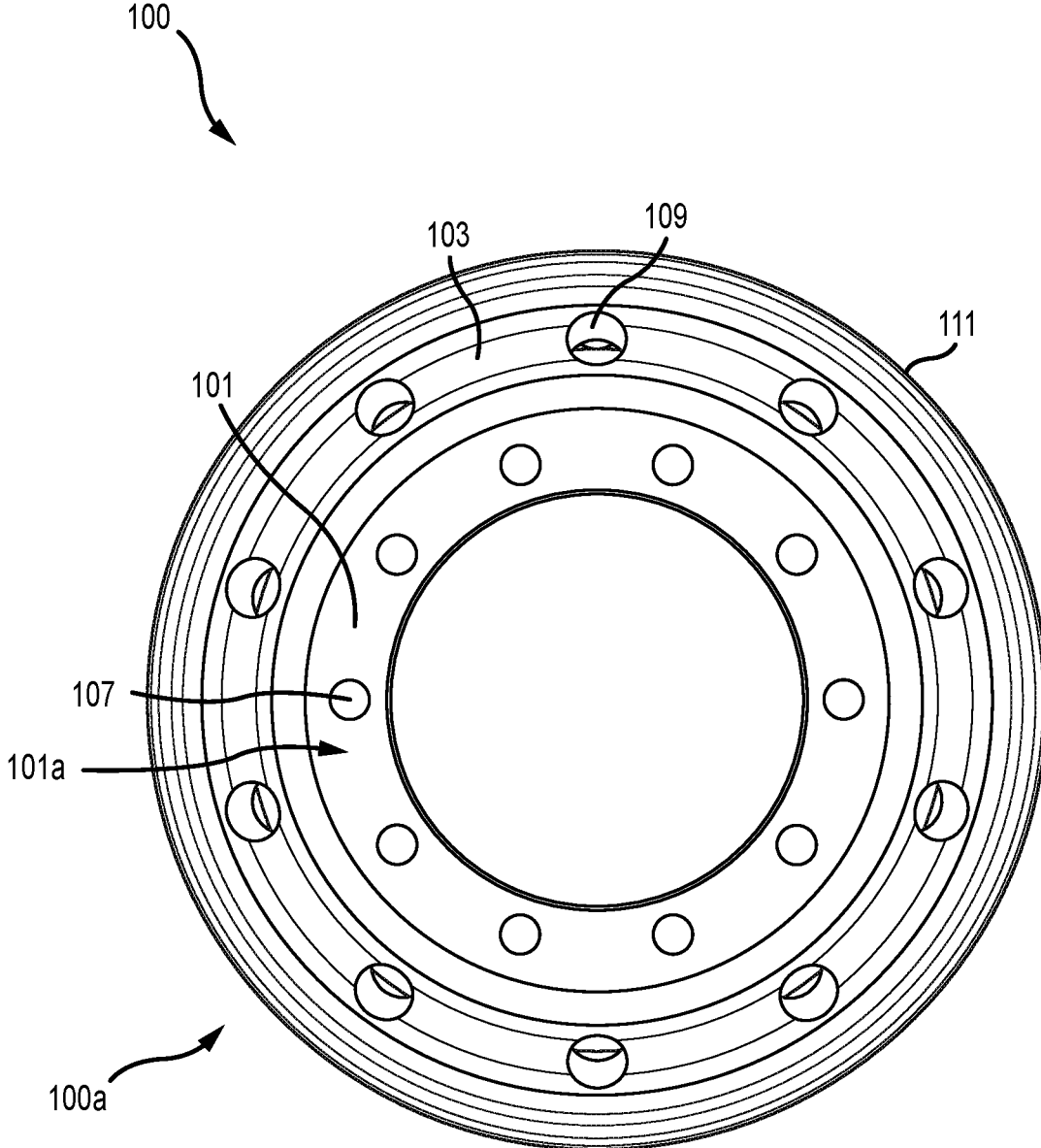

FIG.1B

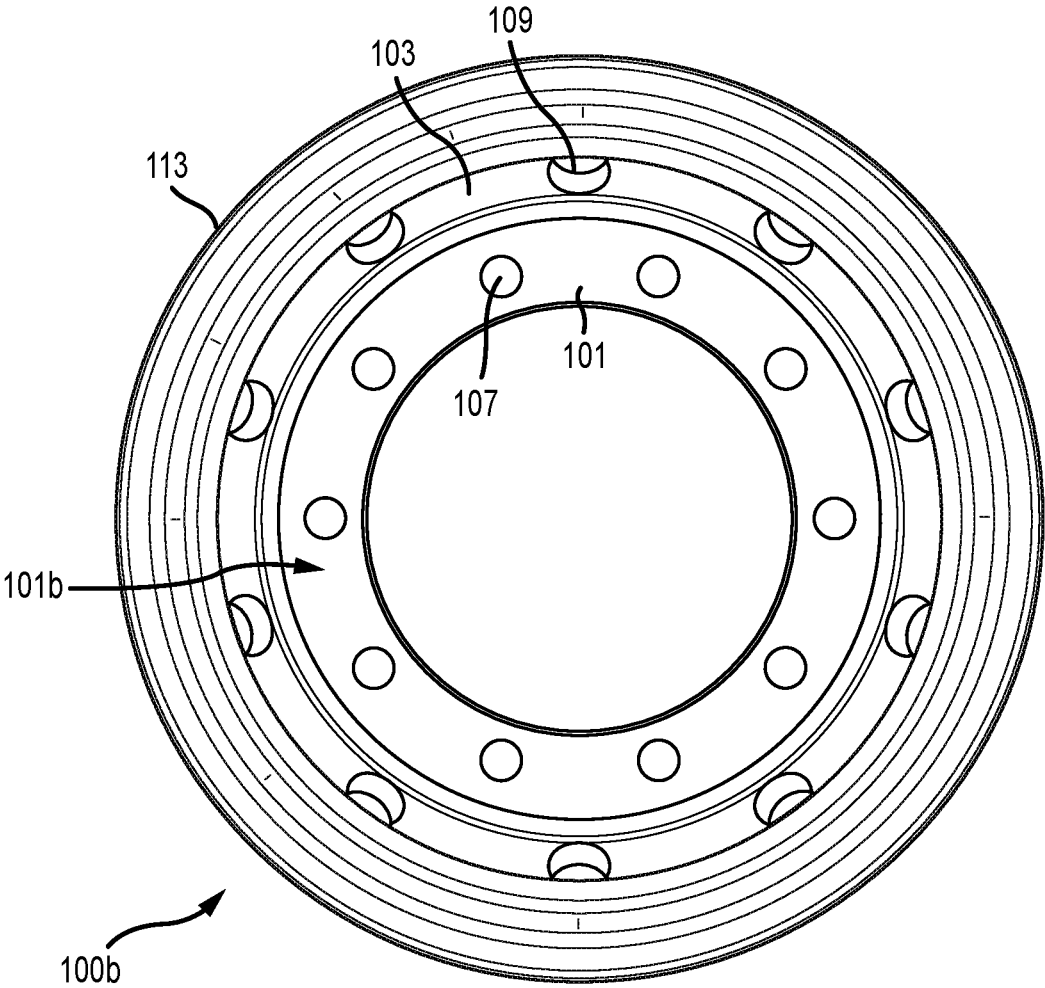

FIG.1C

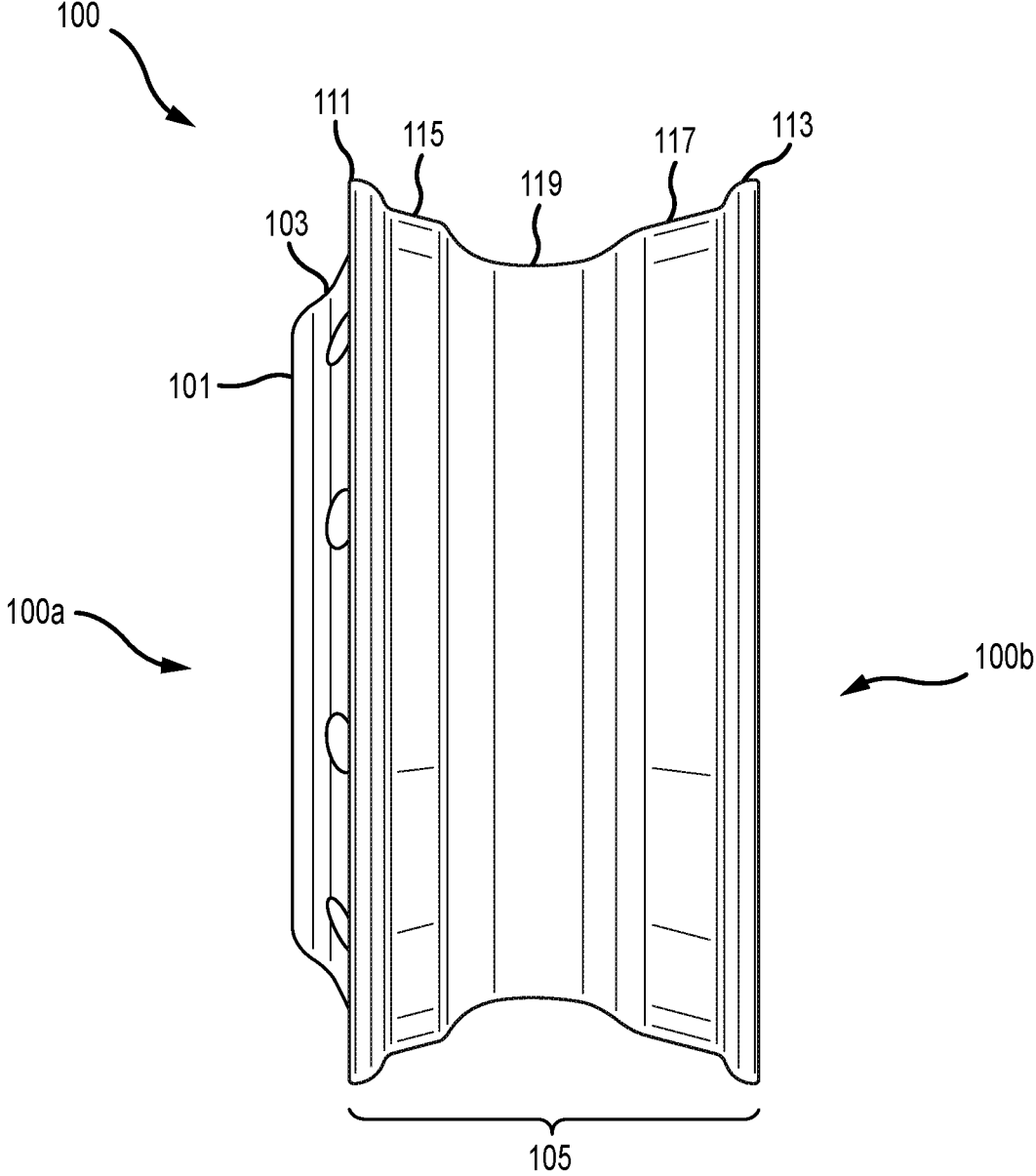

FIG.1D

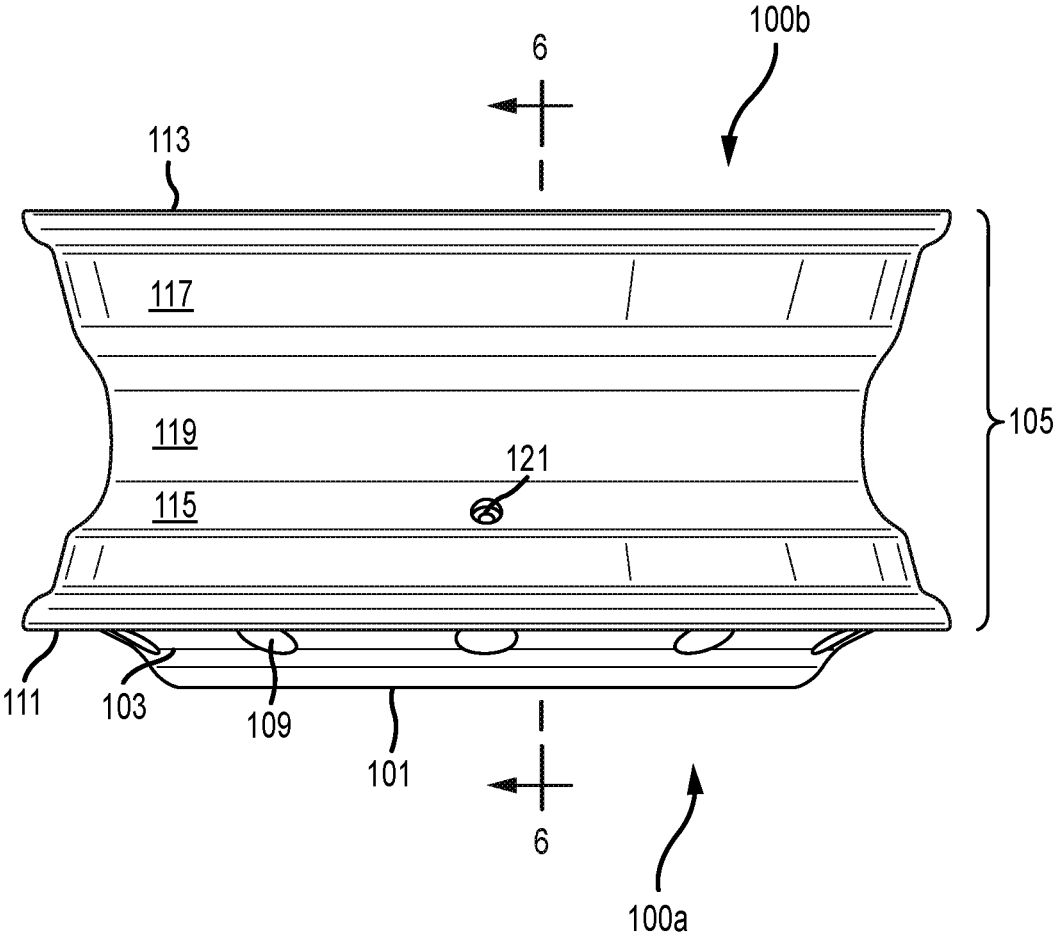

FIG. 1E

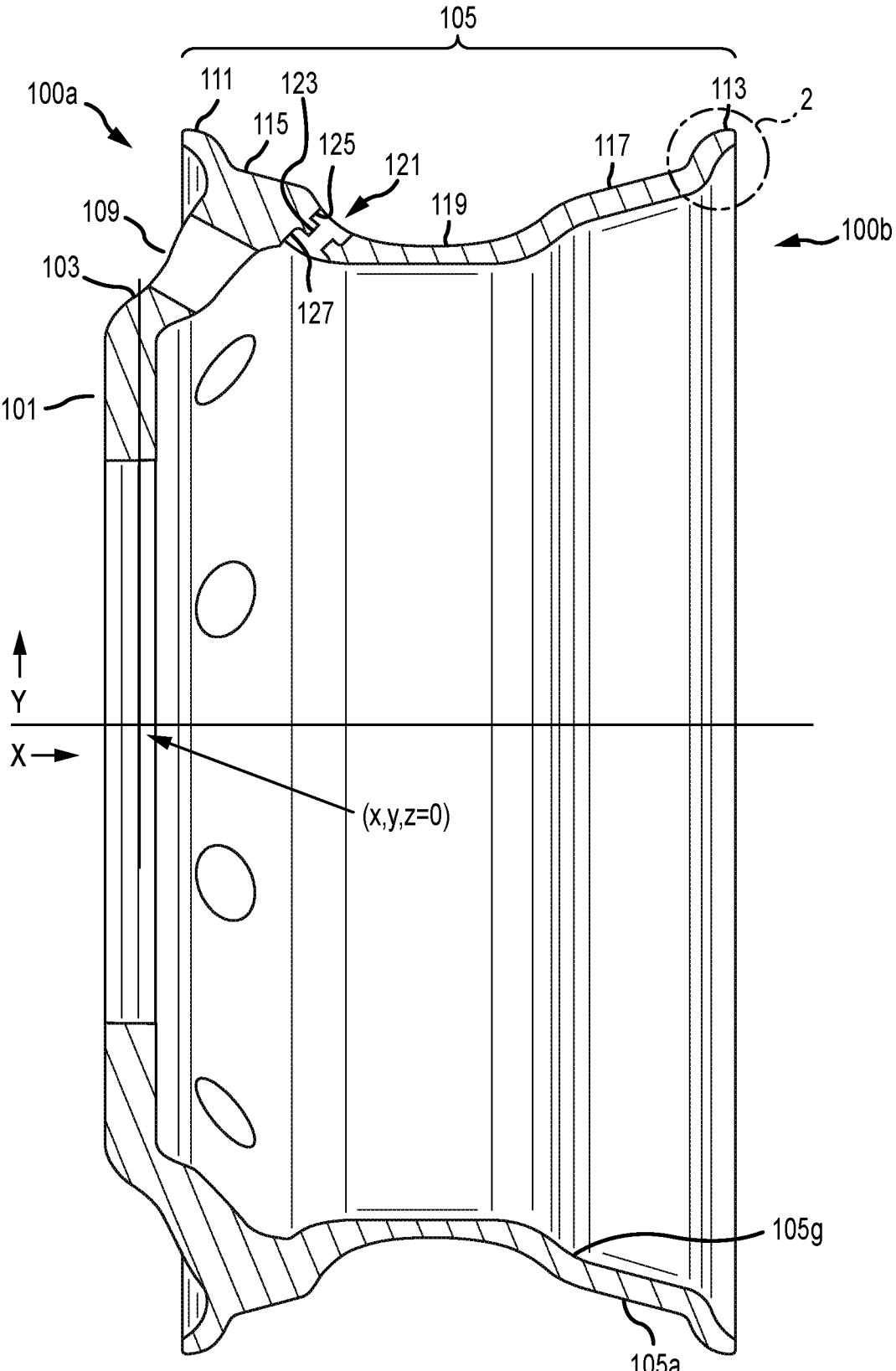

FIG. 1F

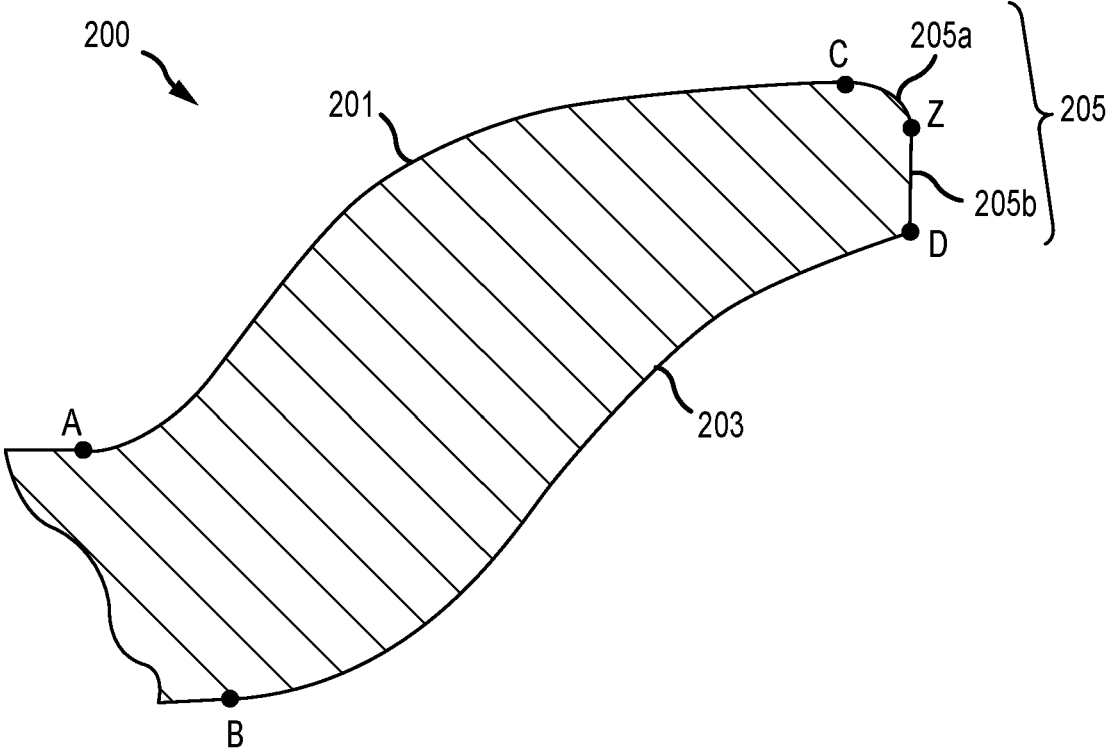

FIG.2

SINGLE PIECE HEAVY DUTY WHEEL

CROSS-REFERENCE TO RELATED APPLICATIONS

[0001] The present application claims the benefit of U.S. Provisional patent application No. 62/561,462 entitled, SINGLE-PIECE HEAVY DUTY WHEEL, filed Sep. 21, 2017, which is incorporated by reference herein in its entirety.

BACKGROUND

[0002] Conventionally, increasing design load and/or increasing target tire pressure requires increasing the size and/or thickness of one or more wheel features, using heavier, stronger materials, adding structural support elements, or combinations thereof. However, regardless of such design changes, when applied loads and tire pressures exceed certain levels, tires can demount and/or slide off the wheel rim, for example, when exposed to the lateral loads generated during vehicle turns.

SUMMARY

[0003] The present disclosure relates to a wheel rim for providing increased design load and increased tire pressure ratings. In one embodiment the wheel rim has a flange profile on a tire side of an open end flange of the wheel rim, the flange profile defined by the equation:

$$y_1 = \left(a_{\theta 1} + \frac{1}{(1 + \exp(a_{\theta 3} + a_{\theta 4} \cdot X_1))^{a_{\theta 5}}} \right) \cdot a_{\theta 2}$$

[0004] wherein, for $0 \leq X_1 \leq 1$, $a_{\theta 1}$ is between -1.004 to -0.974 , $a_{\theta 2}$ is between -1.049 to -1.0182 , $a_{\theta 3}$ is between -3.601 to -2.760 , $a_{\theta 4}$ is between 18.791 to 25.965 , and $a_{\theta 5}$ is between 0.185 to 0.277 .

[0005] In another embodiment, $a_{\theta 1}$ is -0.989 , $a_{\theta 2}$ is 1.034 , $a_{\theta 3}$ is -3.181 , $a_{\theta 4}$ is 22.378 , and $a_{\theta 5}$ is 0.231 .

[0006] In another embodiment, a flange profile on an inboard side of the open end flange of the wheel rim is defined by the equation:

$$y_2 = \left(b_{\theta 1} + \frac{1}{(1 + \exp(b_{\theta 3} + b_{\theta 4} \cdot X_2))^{b_{\theta 5}}} \right) \cdot b_{\theta 2} + (\text{Alpha}0 + \text{Alpha}1 \cdot X_2 + \text{Alpha}2 \cdot X_2^2 + \text{Alpha}3 \cdot X_2^3)$$

[0007] wherein, for $0 \leq X_2 \leq 1$, $b_{\theta 1}$ is between -1.319 to -1.065 , $b_{\theta 2}$ is between 0.0001 to 6.277 , $b_{\theta 3}$ is between -7.536 to -2.786 , $b_{\theta 4}$ is between 7.384 to 16.538 , $b_{\theta 5}$ is between -0.234 to -0.159 , $\text{Alpha}0$ is 0 , $\text{Alpha}1$ is between -3.534 to -0.0001 , $\text{Alpha}2$ is between 1.090 to 13.597 , and $\text{Alpha}3$ is between -16.537 to -10.472 .

[0008] In another embodiment, $b_{\theta 1}$ is -1.192 , $b_{\theta 2}$ is 3.126 , $b_{\theta 3}$ is -5.161 , $b_{\theta 4}$ is 11.961 , $b_{\theta 5}$ is -0.197 , $\text{Alpha}0$ is 0 , $\text{Alpha}1$ is -1.500 , $\text{Alpha}2$ is 7.343 , and $\text{Alpha}3$ is -13.505 .

[0009] In another embodiment, the wheel has a third flange profile connecting the first flange profile and the

second flange profile, the third flange profile having a first portion and a second portion, wherein:

[0010] the first portion is defined by the equation:

$$y_3 = \text{Beta}0 + \text{Beta}1 \cdot X_3 + \text{Beta}2 \cdot X_3^2 + \text{Beta}3 \cdot X_3^3 + \text{Beta}4 \cdot X_3^4,$$

[0011] wherein, for $0 \leq X_3 \leq 1$, $\text{Beta}0$ is between -874.899 to -347.942 , $\text{Beta}1$ is between 1651.049 to 3667.375 , $\text{Beta}2$ is between -5733.990 to -2841.300 , $\text{Beta}3$ is between 2125.823 to 3969.923 , and $\text{Beta}4$ is between 1027.410 to -586.633 ; and

[0012] the second portion is defined by the equation:

$$X_4 = \text{Constant}$$

for $y_2 < y < y_3$.

[0013] In another embodiment, $\text{Beta}0$ is -611.42 , $\text{Beta}1$ is 2659.212 , $\text{Beta}2$ is -4287.640 , $\text{Beta}3$ is 3047.873 , and $\text{Beta}4$ is -807.023 .

[0014] In another embodiment, the wheel has a disc end flange mirroring the open end flange.

[0015] In another embodiment, the wheel has a first angle wall extending from the disc end flange toward the open end flange; a second angle wall extending from the open end flange toward the disc end flange; and a drop well connecting the first angle wall and the second angle wall.

[0016] In another embodiment, the wheel has a mounting flange extending radially inward from the disc face, the mounting flange having a plurality of bolt holes.

[0017] In another embodiment, the wheel rim is formed from at least one of steel, aluminum, steel alloys, aluminum alloys, or combinations thereof.

[0018] In another embodiment, the wheel exhibits a maximum load rating increase by a factor of 1.5 with a corresponding increase in the weight of the wheel by a factor of 1.3 over a wheel with a standard geometry.

[0019] In another embodiment, the wheel exhibits a maximum tire pressure rating by a factor of 1.375 with a corresponding increase in the maximum tire pressure rating of the wheel by a factor of 1.298 over a wheel with a standard geometry.

[0020] In another embodiment, a method for making a wheel includes forming the wheel by at least one of forging or casting the wheel, the wheel having a disc face at a disc end, an opposing open end, and a wheel rim extending between the disc face and the open end, the wheel rim including a flange profile on a tire side of an open end flange of the wheel rim, the flange profile defined by the equation:

$$y_1 = \left(a_{\theta 1} + \frac{1}{(1 + \exp(a_{\theta 3} + a_{\theta 4} \cdot X_1))^{a_{\theta 5}}} \right) \cdot a_{\theta 2}$$

[0021] wherein, for $0 \leq X_1 \leq 1$, $a_{\theta 1}$ is between -1.004 to -0.974 , $a_{\theta 2}$ is between -1.049 to -1.0182 , $a_{\theta 3}$ is between -3.601 to -2.760 , $a_{\theta 4}$ is between 18.791 to 25.965 , and $a_{\theta 5}$ is between 0.185 to 0.277 .

[0022] In another embodiment, $a_{\theta 1}$ is -0.989 , $a_{\theta 2}$ is 1.034 , $a_{\theta 3}$ is -3.181 , $a_{\theta 4}$ is 22.378 , and $a_{\theta 5}$ is 0.231 .

[0023] In another embodiment, the step of forming further comprises forming a flange profile on an inboard side of the open end flange of the wheel rim, the flange profile defined by the equation:

$$y_2 = \left(b\theta_1 + \frac{1}{(1 + \exp(b\theta_3 + b\theta_4 \cdot X_2))^{b\theta_5}} \right) \cdot b\theta_2 + (\text{Alpha}0 + \text{Alpha}1 \cdot X_2 + \text{Alpha}2 \cdot X_2^2 + \text{Alpha}3 \cdot X_2^3)$$

[0024] wherein, for $0 \leq X_2 \leq 1$, $b\theta_1$ is between -1.319 to -1.065 , $b\theta_2$ is between 0.0001 to 6.277 , $b\theta_3$ is between -7.536 to -2.786 , $b\theta_4$ is between 7.384 to 16.538 , $b\theta_5$ is between -0.234 to -0.159 , $\text{Alpha}0$ is 0 , $\text{Alpha}1$ is between -3.534 to -0.0001 , $\text{Alpha}2$ is between 1.090 to 13.597 , and $\text{Alpha}3$ is between -16.537 to -10.472 .

[0025] In another embodiment, $b\theta_1$ is -1.192 , $b\theta_2$ is 3.126 , $b\theta_3$ is -5.161 , $b\theta_4$ is 11.961 , $b\theta_5$ is -0.197 , $\text{Alpha}0$ is 0 , $\text{Alpha}1$ is -1.500 , $\text{Alpha}2$ is 7.343 , and $\text{Alpha}3$ is -13.505 .

[0026] In another embodiment, the step of forming further comprises forming a third flange profile connecting the first flange profile and the second flange profile, the third flange profile having a first portion and a second portion, wherein:

[0027] the first portion is defined by the equation:

$$y_3 = \text{Beta}0 + \text{Beta}1 \cdot X_3 + \text{Beta}2 \cdot X_3^2 + \text{Beta}3 \cdot X_3^3 + \text{Beta}4 \cdot X_3^4,$$

[0028] wherein, for $0 \leq X_3 \leq 1$, $\text{Beta}0$ is between -874.899 to -347.942 , $\text{Beta}1$ is between 1651.049 to 3667.375 , $\text{Beta}2$ is between -5733.990 to -2841.300 , $\text{Beta}3$ is between 2125.823 to 3969.923 , and $\text{Beta}4$ is between 1027.410 to -586.633 ; and

[0029] the second portion is defined by the equation:

$$X_4 = \text{Constant}$$

for $y_2 < y < y_3$.

[0030] In another embodiment, the wheel rim further comprises a disc end flange mirroring the open end flange.

[0031] In another embodiment, the wheel is forged or cast from at least one of steel, aluminum, steel alloys, aluminum alloys, or combinations thereof.

[0032] In another embodiment, $X_4 = 1$.

BRIEF DESCRIPTION OF THE DRAWINGS

[0033] Illustrative, non-limiting example embodiments will be more clearly understood from the following detailed description taken in conjunction with the accompanying drawings.

[0034] FIGS. 1A-1F are perspective, front, back, side, top, and cross-sectional views of a wheel in accordance with various embodiments.

[0035] FIG. 2 is an enlarged fragmentary view of a cross-section of an open end flange of the wheel of FIG. 1F.

DETAILED DESCRIPTION OF THE EMBODIMENTS

[0036] Various exemplary embodiments will be described more fully hereinafter with reference to the accompanying drawings, in which some example embodiments are shown. The present inventive concept may, however, be embodied in many different forms and should not be construed as limited to the example embodiments set forth herein. Rather, these example embodiments are provided so that this disclosure will be thorough and complete, and will fully convey the scope of the present inventive concept to those skilled in the art. In the drawings, the sizes and relative sizes of layers and regions may be exaggerated for clarity.

[0037] It will be understood that when an element is referred to as being “connected” or “coupled” to another element, it can be directly connected or coupled to the other element or intervening elements may be present. In contrast, when an element is referred to as being “directly connected” or “directly coupled” to another element, there are no intervening elements present. Other words used to describe the relationship between elements should be interpreted in a like fashion (e.g., “between” versus “directly between,” “adjacent” versus “directly adjacent,” etc.).

[0038] Unless otherwise defined, all terms (including technical and scientific terms) used herein have the same meaning as commonly understood by one of ordinary skill in the art to which this inventive concept belongs. It will be further understood that terms, such as those defined in commonly used dictionaries, should be interpreted as having a meaning that is consistent with their meaning in the context of the relevant art and will not be interpreted in an idealized or overly formal sense unless expressly so defined herein.

[0039] Embodiments of the present disclosure generally apply to wheels. The various embodiments of the present disclosure can provide single piece heavy duty wheels having a high load rating and a high tire inflation pressure rating for use in connection with wheeled vehicles such as, for example, cars, trucks, buses, aircraft landing gear, amphibious vehicles, or any other wheeled vehicle.

[0040] FIGS. 1A-1F illustrate a wheel **100** having a disc end **100a** and an opposing open end **100b** in accordance with various embodiments of the present disclosure. The wheel **100** can include a mount flange **101** at the disc end **100a** extending radially inward from a disc face **103** for mounting the wheel **100** to a wheel hub (not shown). The wheel **100** can also include a wheel rim **105** extending between the disc face **103** and the open end **100b**.

[0041] The mount flange **101**, in accordance with various embodiments, can include one or more bolt holes **107** extending there through for bolting or otherwise fastening the wheel **100** to the wheel hub. Although the mount flange **101** is shown in FIGS. 1A-1F as having 10 bolt holes **107**, it will be apparent in view of this disclosure that any number and/or size bolt holes **107** can be used in accordance with various embodiments to permit engagement between the mount flange **101** and any complimentary wheel hub design.

[0042] As shown in FIGS. 1A, 1B, 1D, and 1E, the mount flange **101**, in accordance with various embodiments, can include a substantially planar outer face **101a** for providing a stable bearing surface for engagement with one or more bolt heads of one or more bolts when the wheel **100** is bolted to the wheel hub. As shown in FIGS. 1C and 1F, the mount flange **101**, in accordance with various embodiments can also include a substantially planar inner face **101b** for providing a stable bearing surface for engagement with the wheel hub when the wheel **100** is bolted to the wheel hub.

[0043] As shown in FIGS. 1A, 1D, 1E, and 1F, the disc face **103**, in accordance with various embodiments, can extend substantially conically between the mount flange **101** and the wheel rim **105** for providing a transition and structural support between the wheel rim **105** and the mount flange **101**. The disc face **103**, in accordance with various embodiments, can include one or more hand holes **109** extending there through for permitting handling of the wheel, for providing cooling ventilation to a brake or brakes proximate the wheel, and/or for providing accessibility to a valve hole for inflation and valve installation. Although the

disc face **103** is shown in FIGS. 1A-1F as having 10 hand holes **109**, it will be apparent in view of this disclosure that any number and/or size hand holes **109** can be used in accordance with various embodiments.

[0044] The wheel rim **105**, in accordance with various embodiments, can be configured for mounting a tire thereto. The wheel rim **105** can, in accordance with various embodiments, include an outer “tire side” **105a** and an inner “inboard side” **105b**. In some embodiments, the wheel rim **105** can include a disc end flange **111** at the disc end **100a**, an open end flange **113** at the open end **100b**, a first angle wall **115** extending from the disc end flange **111** toward the open end flange **113**, a second angle wall **117** extending from the open end flange **113** toward the disc end flange **111**, and a drop well **119** connecting the first angle wall **115** to the second angle wall **117**. In some embodiments, the wheel rim **105** can also include a valve hole **121** extending through at least one of the first angle wall **115**, the second angle wall **117**, or the drop well **119**.

[0045] FIG. 1F shows a Cartesian coordinate system with X and Y axes imposed on a cross-section of the wheel **100**. The origin, where x, y and z=0 is positioned at the intersection of the wheel flange and the centerline (axis of rotation) of the wheel, which defines the X axis. The Y axis extends perpendicularly through the X-axis within the mount flange **101**. The variables X and Y in the equations below are measured in the coordinate system shown in FIG. 1F. To provide stability to the fitting algorithms expressed below, the X and Y coordinates in the original measurement coordinate system may be scaled closer to (0, 1). This is done because the model contains exponential terms and power terms and, if the numbers are too large, the corresponding parameters (the theta, etc.) can become too small and cause instability in the fitting algorithm. For that reason, each x1, x2, x3, x4 may be expressed as:

$$Xi=(X-10.271)/0.996$$

And each y1, y2, y3, y4 may be expressed as:

$$Yi=(Y-11.205)/0.705$$

Using this scaling approach, the point (10.271, 11.205) is mapped to (0,0) and the point (11.267, 11.910) is mapped to (1,1). All points are in the XY plane, with the Z value=0.

[0046] In accordance with various embodiments, the first angle wall **115**, second angle wall **117**, and drop well **119** can be sized and shaped to have a tire side profile geometry conforming to the Tire and Rim Association Standard for drop center rims and flat base rims. The valve hole **121**, in accordance with various embodiments, can be any size, shape, configuration, and orientation suitable for installation of an inflation valve therein. For example, in some embodiments, as shown in FIG. 1F, the valve hole **121** can include a through hole **123**, a tire side counterbore **125**, and an inboard counterbore **127**.

[0047] The disc end flange **111** and the open end flange **113**, in some embodiments, can each generally be sized and shaped to have a tire side profile geometry conforming to the Tire and Rim Association Standard for drop center rims and flat base rims. In some embodiments, particular profiles of the tire side and inboard sides of the disc end flange **111** and the open end flange **113** can include particular profile patterns as described in greater detail below with reference to FIG. 2 in order to permit increased load ratings and increased tire pressure ratings without excessively increasing weight or increasing the risk of the tire demounting from

the rim. For example, in some embodiments, use of the flange design described below with reference to FIG. 2 can, in part, provide a wheel having a maximum load rating increased from 10,000 lb to 15,000 lb (by a factor of 1.5) and a tire pressure rating increased from 160 PSI to 220 PSI (by a factor of 1.375) while only increasing the weight of the wheel from 25.5 kg (56.3 lb) to 33.1 kg (72.9 lb) (by a factor of 1.298). It will be apparent in view of this disclosure, however, that in some embodiments, the flange design of the subject patent application can be implemented in connection with wheels having any combination of a maximum pressure rating less than 220 PSI and/or any maximum load rating less than 15,000 lb. For example, in some embodiments, the wheel can include a maximum tire pressure rating of 160 PSI and a maximum load rating of 15,000 lb.

[0048] In some embodiments, the disc end flange **111** and the open end flange **113** can include mirrored tire side and inboard side profile patterns. In some embodiments, the disc end flange **111** and the open end flange **113** can include different tire side and/or inboard side profile patterns.

[0049] The wheel **100**, in accordance with various embodiments, can be a single-piece wheel made by forging or casting the wheel **100** using, for example, one or more of impression die forging, cold forging, open die forging, seamless rolled forging, any expendable mold casting (e.g., sand casting, plaster mold casting, shell molding, investment casting), any non-expendable mold casting (e.g., permanent mold casting, die casting, centrifugal casting), gravity filled casting, low-pressure filled casting, high-pressure filled casting, vacuum casting, any other method of forging or casting, or combinations thereof. As used herein, single-piece means that the wheel **100** does not require welding, screwing, bolting, press-fitting, adhering, or otherwise fastening, attaching, or affixing separate parts. By way of non-limiting example, the wheel **100** is formed from a single casting or forging or is additively manufactured. The wheel **100**, in accordance with various embodiments can be made from any suitable material including, for example, steel, aluminum, steel alloys, aluminum alloys, any other metal, any other alloy, or combinations thereof including composites, reinforced plastics or materials printed or otherwise deposited and fixed into a structure by additive manufacturing techniques.

[0050] In some embodiments, each of the features (e.g., mount flange **101**, disc face **103**, wheel rim **105**, bolt holes **107**, hand holes **109**, disc end flange **111**, open end flange **113**, first and second angle walls **115**, **117**, drop well **119**, and valve hole **121**) of the wheel **100** can be formed during forging or casting. In some embodiments, one or more of the features of the wheel **100** can be subsequently added by any of one or more suitable techniques such as, for example, turning lathe machining, computer numerical control (CNC) machining, drilling, electrical discharge machining, electrochemical machining, any other suitable technique, or combinations thereof.

[0051] FIG. 2 illustrates a detail view of an open end flange **200** which can, in accordance with various embodiments, be similar to, but is not limited to, the open end flange **113** discussed above with reference to FIGS. 1A-1F. In the embodiment shown in FIG. 2, the open end flange **200** includes a tire side profile **201** (illustrated diagrammatically as extending between points A and C), an inboard side profile **203** (illustrated diagrammatically as extending between points B and D), and an end profile **205** (illustrated

diagrammatically as extending between points C and D) having a first portion **205a** (illustrated diagrammatically as extending between points C and Z) and a second portion **205b** (illustrated diagrammatically as extending between points Z and D) for connecting the tire side profile **201** to the inboard side profile **203**.

[0052] The tire side profile **201**, in accordance with various embodiments, can be defined by Equation (1):

$$y_1 = \left(a\theta_1 + \frac{1}{(1 + \text{Exp}(a\theta_3 + a\theta_4 \cdot X_1))^{a\theta_5}} \right) \cdot a\theta_2 \quad (1)$$

wherein, for $0 \leq X_1 \leq 1$, $a\theta_1$ can be between -1.004 to -0.974 , including, for example, between -0.990 to -0.988 and $a\theta_2$ can be between -1.049 to -1.0182 , including, for example, between -1.035 to -1.033 . $a\theta_3$ can be between -3.601 to -2.760 , including, for example, between -3.231 to -3.131 , and between -3.201 to -3.161 . $a\theta_4$ can be 18.791 to 25.965 , including, for example, between 21.700 to 23.100 , between 22.078 to 22.678 , and between 22.278 to 23.478 . $a\theta_5$ can be between 0.185 to 0.277 including, for example, between 0.225 to 0.236 . In one specific embodiment, for $0 \leq X_1 \leq 1$, $a\theta_1$ is -0.989 , $a\theta_2$ is 1.034 , $a\theta_3$ is -3.181 , $a\theta_4$ is 22.378 , and $a\theta_5$ is 0.231 .

[0053] The inboard side profile **203**, in accordance with various embodiments, can be defined by Equation (2):

$$y_2 = \left(b\theta_1 + \frac{1}{(1 + \text{Exp}(b\theta_3 + b\theta_4 \cdot X_2))^{b\theta_5}} \right) \cdot b\theta_2 + \quad (2)$$

$$(\text{Alpha}0 + \text{Alpha} \cdot X_2 + \text{Alpha}2 \cdot X_2^2 + \text{Alpha}3 \cdot X_2^3)$$

wherein, for $0 \leq X_2 \leq 1$, $b\theta_1$ can be between -1.319 to -1.065 , including, for example, between -1.212 to -1.172 , and -1.202 to -1.182 , $b\theta_2$ can be between 0.0001 to 6.277 , including, for example, between 2.626 to 3.726 , between 2.826 to 3.426 , and between 3.026 to 3.226 . $b\theta_3$ can be between -7.536 to -2.786 , including, for example, between -5.561 to -4.761 , between -5.361 to -4.961 , and between -5.261 to -5.061 . $b\theta_4$ can be between 7.384 to 16.538 , including, for example, between 11.161 to 12.861 , between 11.461 to 12.461 , and between 11.761 to 12.161 . $b\theta_5$ can be between -0.234 to -0.159 , including, for example, between -0.200 to -0.194 . $\text{Alpha}0$, in some embodiments, can be 0 . $\text{Alpha}1$ can be between -3.534 to -0.0001 , including, for example, between -1.700 to -1.300 . $\text{Alpha}2$ can be between 1.090 to 13.597 , including, for example, between 6.143 to 8.543 , between 6.443 to 8.143 , and between 6.943 to 7.743 . $\text{Alpha}3$ can be between -16.537 to -10.472 , including, for example, between -13.905 to -13.105 and between -13.705 to -13.305 . In one specific embodiment, for $0 \leq X_2 \leq 1$, $b\theta_1$ is -1.192 , $b\theta_2$ is 3.126 , $b\theta_3$ is -5.161 , $b\theta_4$ is 11.961 , $b\theta_5$ is -0.197 , $\text{Alpha}0$ is 0 , $\text{Alpha}1$ is -1.500 , $\text{Alpha}2$ is 7.343 , and $\text{Alpha}3$ is -13.505 .

[0054] The first portion **205a** of the end profile, in accordance with various embodiments, can be defined by Equation (3):

$$y_3 = \text{Beta}0 + \text{Beta}1 \cdot X_3 + \text{Beta}2 \cdot X_3^2 + \text{Beta}3 \cdot X_3^3 + \text{Beta}4 \cdot X_3^4, \quad (3)$$

[0055] wherein, for $0 \leq X_3 \leq 1$, $\text{Beta}0$ can be between -874.899 to -347.942 , including, for example, between -801 to -401 , between -761 to -461 , between -711 to -511 , and between -661 to -561 , $\text{Beta}1$ can be between 1651.049 to 3667.375 , including, for example, between 1859 to 3359 , between 2059 to 3159 , and between 2359 to 2959 , $\text{Beta}2$ can be between -5733.990 to -2841.300 , including, for example, between -5087 to -3487 , between -4687 to -3887 , and between -4487 to -4087 , $\text{Beta}3$ can be between 2125.823 to 3969.923 , including, for example, between 2447 to 3647 , between 2647 to 3447 , and between 2847 to 3247 . $\text{Beta}4$ can be between 1027.410 to -586.633 , including, for example, between -907 to -707 and between -857 to -757 . In one specific embodiment, for $0 \leq X_3 \leq 1$, $\text{Beta}0$ is -611.42 , $\text{Beta}1$ is 2659.212 , $\text{Beta}2$ is -4287.640 , $\text{Beta}3$ is 3047.873 , and $\text{Beta}4$ is -807.023 . The second portion **205b** of the third flange profile is defined by Equation (4):

$$X_4 = \text{Constant} \quad (4)$$

for $y_2 < y < y_3$.

[0056] The open end flange **200**, in some embodiments, the tire side **201** and inboard side **203** profile patterns can be mirrored on a disc end flange. Alternatively, in some embodiments, the disc end flange can include different tire side and/or inboard side profile patterns.

[0057] While the present disclosure has been described with reference to certain embodiments thereof, it should be understood by those skilled in the art that various changes may be made and equivalents may be substituted without departing from the true spirit and scope of the disclosure. In addition, many modifications may be made to adapt to a particular situation, indication, material and composition of matter, process step or steps, without departing from the spirit and scope of the present disclosure. All such modifications are intended to be within the scope of the claims appended hereto.

[0058] The figures constitute a part of this specification and include illustrative embodiments of the present disclosure and illustrate various objects and features thereof. In addition, any measurements, specifications and the like shown in the figures are intended to be illustrative, and not restrictive. Therefore, specific structural and functional details disclosed herein are not to be interpreted as limiting, but merely as a representative basis for teaching one skilled in the art to variously employ the present invention.

[0059] Among those benefits and improvements that have been disclosed, other objects and advantages of this invention will become apparent from the preceding description taken in conjunction with the accompanying figures. Detailed embodiments of the present invention are disclosed herein; however, it is to be understood that the disclosed embodiments are merely illustrative of the invention that may be embodied in various forms. In addition, each of the examples given in connection with the various embodiments of the invention is intended to be illustrative, and not restrictive.

[0060] Throughout the specification and claims, the following terms take the meanings explicitly associated herein, unless the context clearly dictates otherwise. The phrases “in one embodiment” and “in some embodiments” as used herein do not necessarily refer to the same embodiment(s), though it may. Furthermore, the phrases “in another embodiment” and “in some other embodiments” as used herein do not necessarily refer to a different embodiment, although it

may. Thus, as described below, various embodiments of the invention may be readily combined, without departing from the scope or spirit of the invention.

[0061] In addition, as used herein, the term “or” is an inclusive “or” operator, and is equivalent to the term “and/or,” unless the context clearly dictates otherwise. The term “based on” is not exclusive and allows for being based on additional factors not described, unless the context clearly dictates otherwise. In addition, throughout the specification, the meaning of “a,” “an,” and “the” include plural references. The meaning of “in” includes “in” and “on”.

[0062] Aspects of the invention will now be described with reference to the following numbered clauses:

1. A wheel rim comprising:

[0063] a flange profile on a tire side of an open end flange of the wheel rim, the flange profile defined by the equation:

$$y_1 = \left(a_{\theta 1} + \frac{1}{(1 + \exp(a_{\theta 3} + a_{\theta 4} \cdot X_1))^{a_{\theta 5}}} \right) \cdot a_{\theta 2}$$

[0064] wherein, for $0 \leq X_1 \leq 1$, $a_{\theta 1}$ is between -1.004 to -0.974 , $a_{\theta 2}$ is between -1.049 to -1.0182 , $a_{\theta 3}$ is between -3.601 to -2.760 , $a_{\theta 4}$ is between 18.791 to 25.965 , and $a_{\theta 5}$ is between 0.185 to 0.277 .

2. The wheel rim of clause 1, wherein $a_{\theta 3}$ is between -3.231 to -3.131 .

3. The wheel rim of any of the preceding clauses, wherein $a_{\theta 3}$ is between -3.201 to -3.161 .

4. The wheel rim of any of the preceding clauses, wherein $a_{\theta 4}$ is between 21.700 to 23.100 .

5. The wheel rim of any of the preceding clauses, wherein $a_{\theta 4}$ is between 22.078 to 22.678 .

6. The wheel rim of any of the preceding clauses, wherein $a_{\theta 4}$ is between 22.278 to 23.478 .

7. The wheel rim of any of the preceding clauses, wherein $a_{\theta 1}$ is -0.989 , $a_{\theta 2}$ is 1.034 , $a_{\theta 3}$ is -3.181 , $a_{\theta 4}$ is 22.378 , and $a_{\theta 5}$ is 0.231 .

8. A wheel rim comprising:

[0065] a flange profile on an inboard side of the open end flange of the wheel rim, the flange profile defined by the equation:

$$y_2 = \left(b_{\theta 1} + \frac{1}{(1 + \exp(b_{\theta 3} + b_{\theta 4} \cdot X_2))^{b_{\theta 5}}} \right) \cdot b_{\theta 2} + (\text{Alpha}0 + \text{Alpha}1 \cdot X_2 + \text{Alpha}2 \cdot X_2^2 + \text{Alpha}3 \cdot X_2^3)$$

[0066] wherein, for $0 \leq X_2 \leq 1$, $b_{\theta 1}$ is between -1.319 to -1.065 , $b_{\theta 2}$ is between 0.0001 to 6.277 , $b_{\theta 3}$ is between -7.536 to -2.786 , $b_{\theta 4}$ is between 7.384 to 16.538 , $b_{\theta 5}$ is between -0.234 to -0.159 , $\text{Alpha}0$ is 0 , $\text{Alpha}1$ is between -3.534 to -0.0001 , $\text{Alpha}2$ is between 1.090 to 13.597 , and $\text{Alpha}3$ is between -16.537 to -10.472 .

9. The wheel rim of any of the preceding clauses, wherein $b_{\theta 1}$ is between -1.212 to -1.172 .

10. The wheel rim of any of the preceding clauses, wherein $b_{\theta 1}$ is between -1.202 to -1.182 .

11. The wheel rim of any of the preceding clauses, wherein $b_{\theta 2}$ is between 2.626 to 3.726 .

12. The wheel rim of any of the preceding clauses, wherein $b_{\theta 2}$ is between 2.826 to 3.426 .

13. The wheel rim of any of the preceding clauses, wherein $b_{\theta 2}$ is between 3.026 to 3.226 .

14. The wheel rim of any of the preceding clauses, wherein $b_{\theta 3}$ is between -5.561 to -4.761 .

15. The wheel rim of any of the preceding clauses, wherein $b_{\theta 3}$ is between -5.361 to -4.961 .

16. The wheel rim of any of the preceding clauses, wherein $b_{\theta 3}$ is between -5.261 to -5.061 .

17. The wheel rim of any of the preceding clauses, wherein $b_{\theta 4}$ is between 11.161 to 12.861 .

18. The wheel rim of any of the preceding clauses, wherein $b_{\theta 4}$ is between 11.461 to 12.461 .

19. The wheel rim of any of the preceding clauses, wherein $b_{\theta 4}$ is between 11.761 to 12.161 .

20. The wheel rim of any of the preceding clauses, wherein $b_{\theta 5}$ is between -0.200 to -0.194 .

21. The wheel rim of any of the preceding clauses, wherein $\text{Alpha}1$ is between -1.700 to -1.300 .

22. The wheel rim of any of the preceding clauses, wherein $\text{Alpha}2$ is between 6.143 to 8.543 .

23. The wheel rim of any of the preceding clauses, wherein $\text{Alpha}2$ is between 6.443 to 8.143 .

24. The wheel rim of any of the preceding clauses, wherein $\text{Alpha}2$ is between 6.943 to 7.743 .

25. The wheel rim of any of the preceding clauses, wherein $\text{Alpha}3$ is between -13.905 to -13.105 .

26. The wheel rim of any of the preceding clauses, wherein $\text{Alpha}3$ is between -13.705 to -13.305 .

27. The wheel rim of any of the preceding clauses, wherein $b_{\theta 1}$ is -1.192 , $b_{\theta 2}$ is 3.126 , $b_{\theta 3}$ is -5.161 , $b_{\theta 4}$ is 11.961 , $b_{\theta 5}$ is -0.197 , $\text{Alpha}0$ is 0 , $\text{Alpha}1$ is -1.500 , $\text{Alpha}2$ is 7.343 , and $\text{Alpha}3$ is -13.505 .

28. The wheel rim of any of the preceding clauses, further comprising a third flange profile connecting the first flange profile and the second flange profile, the third flange profile having a first portion and a second portion, wherein:

[0067] the first portion is defined by the equation:

$$y_3 = \text{Beta}0 + \text{Beta}1 \cdot X_3 + \text{Beta}2 \cdot X_3^2 + \text{Beta}3 \cdot X_3^3 + \text{Beta}4 \cdot X_3^4,$$

[0068] wherein, for $0 \leq X_3 \leq 1$, $\text{Beta}0$ is between -874.899 to -347.942 , $\text{Beta}1$ is between 1651.049 to 3667.375 , $\text{Beta}2$ is between -5733.990 to -2841.300 , $\text{Beta}3$ is between 2125.823 to 3969.923 , and $\text{Beta}4$ is between 1027.410 to -586.633 ; and

[0069] the second portion is defined by the equation:

$$X_4 = \text{Constant}$$

for $y_2 < y < y_3$.

29. The wheel rim of any of the preceding clauses, wherein $\text{Beta}0$ is between -801 to -401 .

30. The wheel rim of any of the preceding clauses, wherein $\text{Beta}0$ is between -761 to -461 .

31. The wheel rim of any of the preceding clauses, wherein $\text{Beta}0$ is between -711 to -511 .

32. The wheel rim of any of the preceding clauses, wherein $\text{Beta}0$ is between -661 to -561 .

33. The wheel rim of any of the preceding clauses, wherein $\text{Beta}1$ is between 1859 to 3359 .

34. The wheel rim of any of the preceding clauses, wherein $\text{Beta}1$ is between 2059 to 3159 .

35. The wheel rim of any of the preceding clauses, wherein $\text{Beta}1$ is between 2359 to 2959 .

36. The wheel rim of any of the preceding clauses, wherein $\text{Beta}2$ is between -5087 to -3487 .

37. The wheel rim of any of the preceding clauses, wherein Beta 2 is between -4687 to -3887.

38. The wheel rim of any of the preceding clauses, wherein Beta 2 is between -4487 to -4087.

39. The wheel rim of any of the preceding clauses, wherein Beta 3 is between 2447 to 3647.

40. The wheel rim of any of the preceding clauses, wherein Beta 3 is between 2647 to 3447.

41. The wheel rim of any of the preceding clauses, wherein Beta 3 is between 2847 to 3247.

42. The wheel rim of any of the preceding clauses, wherein Beta 4 is between -907 to -707.

43. The wheel rim of any of the preceding clauses, wherein Beta 4 is between -857 to -757.

44. The wheel rim of any of the preceding clauses, wherein Beta0 is -611.42, Beta1 is 2659.212, Beta2 is -4287.640, Beta3 is 3047.873, and Beta4 is -807.023.

45. The wheel rim of any of the preceding clauses, further comprising a disc end flange mirroring the open end flange.

46. The wheel rim of any of the preceding clauses, further comprising:

[0070] a first angle wall extending from the disc end flange toward the open end flange;

[0071] a second angle wall extending from the open end flange toward the disc end flange; and

[0072] a drop well connecting the first angle wall and the second angle wall.

47. The wheel rim of any of the preceding clauses, wherein the wheel rim is formed from at least one of steel, aluminum, steel alloys, aluminum alloys, or combinations thereof.

48. A method for making a wheel comprising:

[0073] forming by at least one of forging or casting a wheel having a disc face at a disc end, an opposing open end, and a wheel rim extending between the disc face and the open end, the wheel rim including:

[0074] a flange profile on a tire side of an open end flange of the wheel rim, the flange profile defined by the equation:

$$y_1 = \left(a\theta_1 + \frac{1}{(1 + \exp(a\theta_3 + a\theta_4 \cdot X_1))^{a\theta_5}} \right) \cdot a\theta_2$$

[0075] wherein, for $0 \leq X_1 \leq 1$, $a\theta_1$ is between -1.004 to -0.974, $a\theta_2$ is between -1.049 to -1.0182, $a\theta_3$ is between -3.601 to -2.760, $a\theta_4$ is between 18.791 to 25.965, and $a\theta_5$ is between 0.185 to 0.277.

49. The method of clause 48, wherein the step of forming further comprises:

[0076] forming a flange profile on an inboard side of the open end flange of the wheel rim, the flange profile defined by the equation:

$$y_2 = \left(b\theta_1 + \frac{1}{(1 + \exp(b\theta_3 + b\theta_4 \cdot X_2))^{b\theta_5}} \right) \cdot b\theta_2 + (\text{Alpha}0) + \text{Alpha} \cdot X_2 + \text{Alpha}2 \cdot X_2^2 + \text{Alpha}3 \cdot X_2^3$$

[0077] wherein, for $0 \leq X_2 \leq 1$, $b\theta_1$ is between -1.319 to -1.065, $b\theta_2$ is between 0.0001 to 6.277, $b\theta_3$ is between -7.536 to -2.786, $b\theta_4$ is between 7.384 to 16.538, $b\theta_5$ is between -0.234 to -0.159, $\text{Alpha}0$ is 0,

$\text{Alpha}1$ is between -3.534 to -0.0001, $\text{Alpha}2$ is between 1.090 to 13.597, and $\text{Alpha}3$ is between -16.537 to -10.472.

50. The method of any of clauses 48-49, wherein the step of forming further comprises forming a third flange profile connecting the first flange profile and the second flange profile, the third flange profile having a first portion and a second portion, wherein:

[0078] the first portion is defined by the equation:

$$y_3 = \text{Beta}0 + \text{Beta}1 \cdot X_3 + \text{Beta}2 \cdot X_3^2 + \text{Beta}3 \cdot X_3^3 + \text{Beta}4 \cdot X_3^4,$$

[0079] wherein, for $0 \leq X_3 \leq 1$, $\text{Beta}0$ is between -874.899 to -347.942, $\text{Beta}1$ is between 1651.049 to 3667.375, $\text{Beta}2$ is between -5733.990 to -2841.300, $\text{Beta}3$ is between 2125.823 to 3969.923, and $\text{Beta}4$ is between 1027.410 to -586.633; and

[0080] the second portion is defined by the equation:

$$X_4 = \text{Constant}$$

for $y_2 < y < y_3$.

51. The method of any of clauses 48-50, wherein the step of forming further comprises forming a disc end flange mirroring the open end flange.

52. The method of any of clauses 48-51, wherein the step of forming further comprises:

[0081] forming a first angle wall extending from the disc end flange toward the open end flange;

[0082] a second angle wall extending from the open end flange toward the disc end flange; and

[0083] a drop well connecting the first angle wall and the second angle wall.

53. The method of any of clauses 48-52, wherein the step of forming further comprises forming a valve hole in at least one of the first angle wall, the second angle wall, or the drop well.

54. The method of any of clauses 48-53, wherein the step of forming further comprises forming at least one hole in the disc face.

55. The method of any of clauses 48-54, wherein the step of forming further comprises a mount flange extending radially inward from the disc face.

56. The method of any of clauses 48-55, wherein the wheel is forged or cast from at least one of steel, aluminum, steel alloys, aluminum alloys, or combinations thereof.

What is claimed is:

1. A wheel rim comprising:

a flange profile on a tire side of an open end flange of the wheel rim, the flange profile defined by the equation:

$$y_1 = \left(a\theta_1 + \frac{1}{(1 + \exp(a\theta_3 + a\theta_4 \cdot X_1))^{a\theta_5}} \right) \cdot a\theta_2$$

wherein, for $0 \leq X_1 \leq 1$, $a\theta_1$ is between -1.004 to -0.974, $a\theta_2$ is between -1.049 to -1.0182, $a\theta_3$ is between -3.601 to -2.760, $a\theta_4$ is between 18.791 to 25.965, and $a\theta_5$ is between 0.185 to 0.277.

2. The wheel rim of claim 1, wherein $a\theta_1$ is -0.989, $a\theta_2$ is 1.034, $a\theta_3$ is -3.181, $a\theta_4$ is 22.378, and $a\theta_5$ is 0.231.

3. The wheel rim of claim 1, wherein a flange profile on an inboard side of the open end flange of the wheel rim is defined by the equation:

$$y_2 = \left(b\theta_1 + \frac{1}{(1 + \exp(b\theta_3 + b\theta_4 \cdot X_2))^{b\theta_5}} \right) \cdot b\theta_2 + (\alpha_0) + \alpha_1 \cdot X_2 + \alpha_2 \cdot X_2^2 + \alpha_3 \cdot X_2^3$$

wherein, for $0 \leq X_2 \leq 1$, $b\theta_1$ is between -1.319 to -1.065 , $b\theta_2$ is between 0.0001 to 6.277 , $b\theta_3$ is between -7.536 to -2.786 , $b\theta_4$ is between 7.384 to 16.538 , $b\theta_5$ is between -0.234 to -0.159 , α_0 is 0 , α_1 is between -3.534 to -0.0001 , α_2 is between 1.090 to 13.597 , and α_3 is between -16.537 to -10.472 .

4. The wheel rim of claim 3, wherein $b\theta_1$ is -1.192 , $b\theta_2$ is 3.126 , $b\theta_3$ is -5.161 , $b\theta_4$ is 11.961 , $b\theta_5$ is -0.197 , α_0 is 0 , α_1 is -1.500 , α_2 is 7.343 , and α_3 is -13.505 .

5. The wheel rim of claim 3, further comprising a third flange profile connecting the first flange profile and the second flange profile, the third flange profile having a first portion and a second portion, wherein:

the first portion is defined by the equation:

$$y_3 = \beta_0 + \beta_1 \cdot X_3 + \beta_2 \cdot X_3^2 + \beta_3 \cdot X_3^3 + \beta_4 \cdot X_3^4,$$

wherein, for $0 \leq X_3 \leq 1$, β_0 is between -874.899 to -347.942 , β_1 is between 1651.049 to 3667.375 , β_2 is between -5733.990 to -2841.300 , β_3 is between 2125.823 to 3969.923 , and β_4 is between 1027.410 to -586.633 ; and

the second portion is defined by the equation:

$$X_4 = \text{Constant}$$

for $y_2 < y < y_3$.

6. The wheel rim of claim 5, wherein β_0 is -611.42 , β_1 is 2659.212 , β_2 is -4287.640 , β_3 is 3047.873 , and β_4 is -807.023 .

7. The wheel rim of claim 5, further comprising a disc end flange mirroring the open end flange.

8. The wheel rim of claim 5, further comprising:

a first angle wall extending from the disc end flange toward the open end flange;

a second angle wall extending from the open end flange toward the disc end flange; and

a drop well connecting the first angle wall and the second angle wall.

9. The wheel rim of claim 8, further comprising a mounting flange extending radially inward from the disc face, the mounting flange having a plurality of bolt holes.

10. The wheel rim of claim 5, wherein the wheel rim is formed from at least one of steel, aluminum, steel alloys, aluminum alloys, or combinations thereof.

11. The wheel rim of claim 7, wherein the wheel exhibits a maximum load rating increase by a factor of 1.5 with a corresponding increase in the weight of the wheel by a factor of 1.3 over a wheel with a standard geometry.

12. The wheel rim of claim 11, wherein the wheel exhibits a maximum tire pressure rating by a factor of 1.375 with a corresponding increase in the maximum tire pressure rating of the wheel by a factor of 1.298 over a wheel with a standard geometry.

13. A method for making a wheel comprising:

forming the wheel by at least one of forging or casting the wheel, the wheel having a disc face at a disc end, an opposing open end, and a wheel rim extending between the disc face and the open end, the wheel rim including: a flange profile on a tire side of an open end flange of the wheel rim, the flange profile defined by the equation:

$$y_1 = \left(a\theta_1 + \frac{1}{(1 + \exp(a\theta_3 + a\theta_4 \cdot X_1))^{a\theta_5}} \right) \cdot a\theta_2$$

wherein, for $0 \leq X_1 \leq 1$, $a\theta_1$ is between -1.004 to -0.974 , $a\theta_2$ is between -1.049 to -1.0182 , $a\theta_3$ is between -3.601 to -2.760 , $a\theta_4$ is between 18.791 to 25.965 , and $a\theta_5$ is between 0.185 to 0.277 .

14. The method of claim 13, wherein $a\theta_1$ is -0.989 , $a\theta_2$ is 1.034 , $a\theta_3$ is -3.181 , $a\theta_4$ is 22.378 , and $a\theta_5$ is 0.231 .

15. The method of claim 13, wherein the step of forming further comprises forming a flange profile on an inboard side of the open end flange of the wheel rim, the flange profile defined by the equation:

$$y_2 = \left(b\theta_1 + \frac{1}{(1 + \exp(b\theta_3 + b\theta_4 \cdot X_2))^{b\theta_5}} \right) \cdot b\theta_2 + (\alpha_0) + \alpha_1 \cdot X_2 + \alpha_2 \cdot X_2^2 + \alpha_3 \cdot X_2^3$$

wherein, for $0 \leq X_2 \leq 1$, $b\theta_1$ is between -1.319 to -1.065 , $b\theta_2$ is between 0.0001 to 6.277 , $b\theta_3$ is between -7.536 to -2.786 , $b\theta_4$ is between 7.384 to 16.538 , $b\theta_5$ is between -0.234 to -0.159 , α_0 is 0 , α_1 is between -3.534 to -0.0001 , α_2 is between 1.090 to 13.597 , and α_3 is between -16.537 to -10.472 .

16. The method of claim 15, wherein $b\theta_1$ is -1.192 , $b\theta_2$ is 3.126 , $b\theta_3$ is -5.161 , $b\theta_4$ is 11.961 , $b\theta_5$ is -0.197 , α_0 is 0 , α_1 is -1.500 , α_2 is 7.343 , and α_3 is -13.505 .

17. The method of claim 15, wherein the step of forming further comprises forming a third flange profile connecting the first flange profile and the second flange profile, the third flange profile having a first portion and a second portion, wherein:

the first portion is defined by the equation:

$$y_3 = \beta_0 + \beta_1 \cdot X_3 + \beta_2 \cdot X_3^2 + \beta_3 \cdot X_3^3 + \beta_4 \cdot X_3^4,$$

wherein, for $0 \leq X_3 \leq 1$, β_0 is between -874.899 to -347.942 , β_1 is between 1651.049 to 3667.375 , β_2 is between -5733.990 to -2841.300 , β_3 is between 2125.823 to 3969.923 , and β_4 is between 1027.410 to -586.633 ; and

the second portion is defined by the equation:

$$X_4 = \text{Constant}$$

for $y_2 < y < y_3$.

18. The method of claim 17, wherein the wheel rim further comprises a disc end flange mirroring the open end flange.

19. The method of claim 18, wherein the wheel is forged or cast from at least one of steel, aluminum, steel alloys, aluminum alloys, or combinations thereof.

20. The method of claim 17, wherein $X_4=1$.

* * * * *