

(No Model.)

4 Sheets—Sheet 1.

E. J. GREGORY.
AUTOMATIC PHOTOGRAPHIC CAMERA.

No. 544,669.

Patented Aug. 20, 1895.

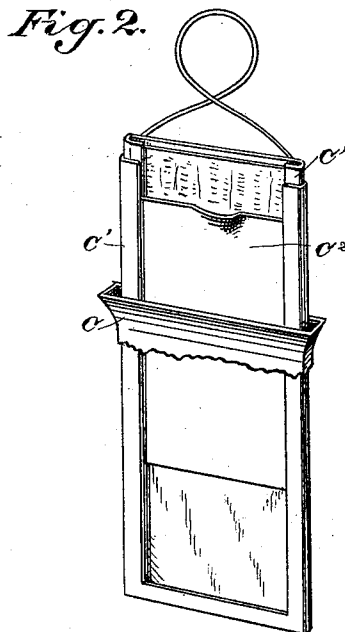
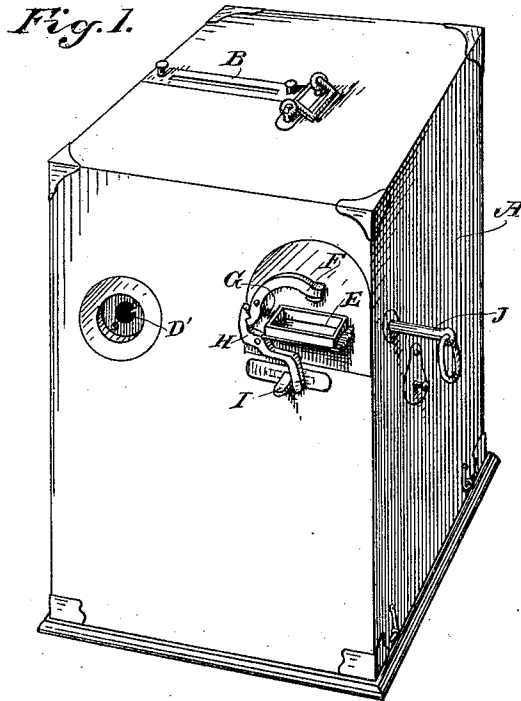

Witnesses,
J. P. Harnse
H. F. Aschbeck

Inventor
Eugene J. Gregory
By Dewey & Co. *attys*

(No Model.)

4 Sheets—Sheet 2.

E. J. GREGORY.
AUTOMATIC PHOTOGRAPHIC CAMERA.

No. 544,669.

Patented Aug. 20, 1895.

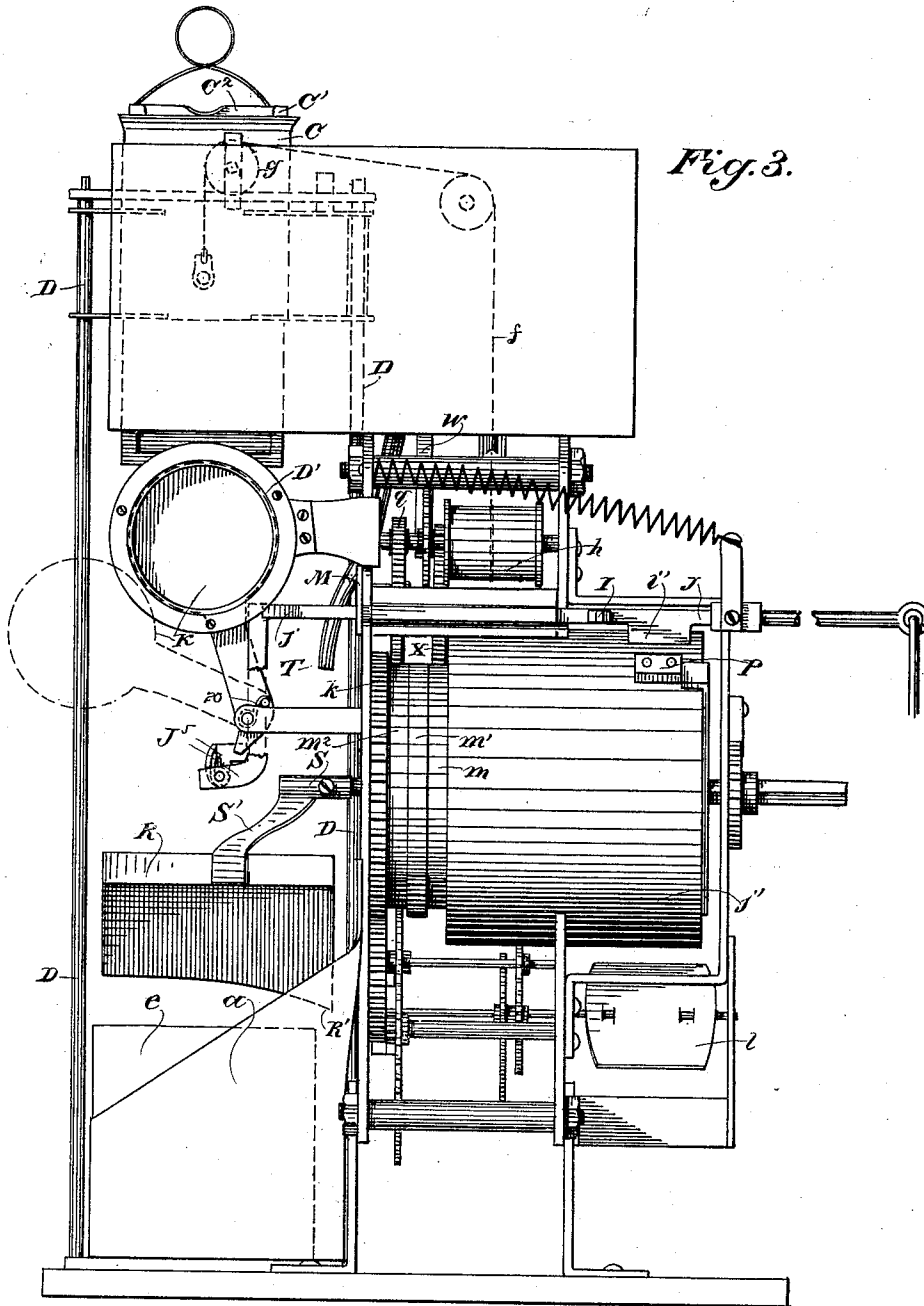

Fig. 3.

Witnesses,
J. H. Strouse
H. F. Clascheck

Inventor
Eugene J. Gregory
By D. W. Dwyer & Co. atty

(No Model.)

4 Sheets—Sheet 3.

E. J. GREGORY.
AUTOMATIC PHOTOGRAPHIC CAMERA.

No. 544,669.

Patented Aug. 20, 1895.

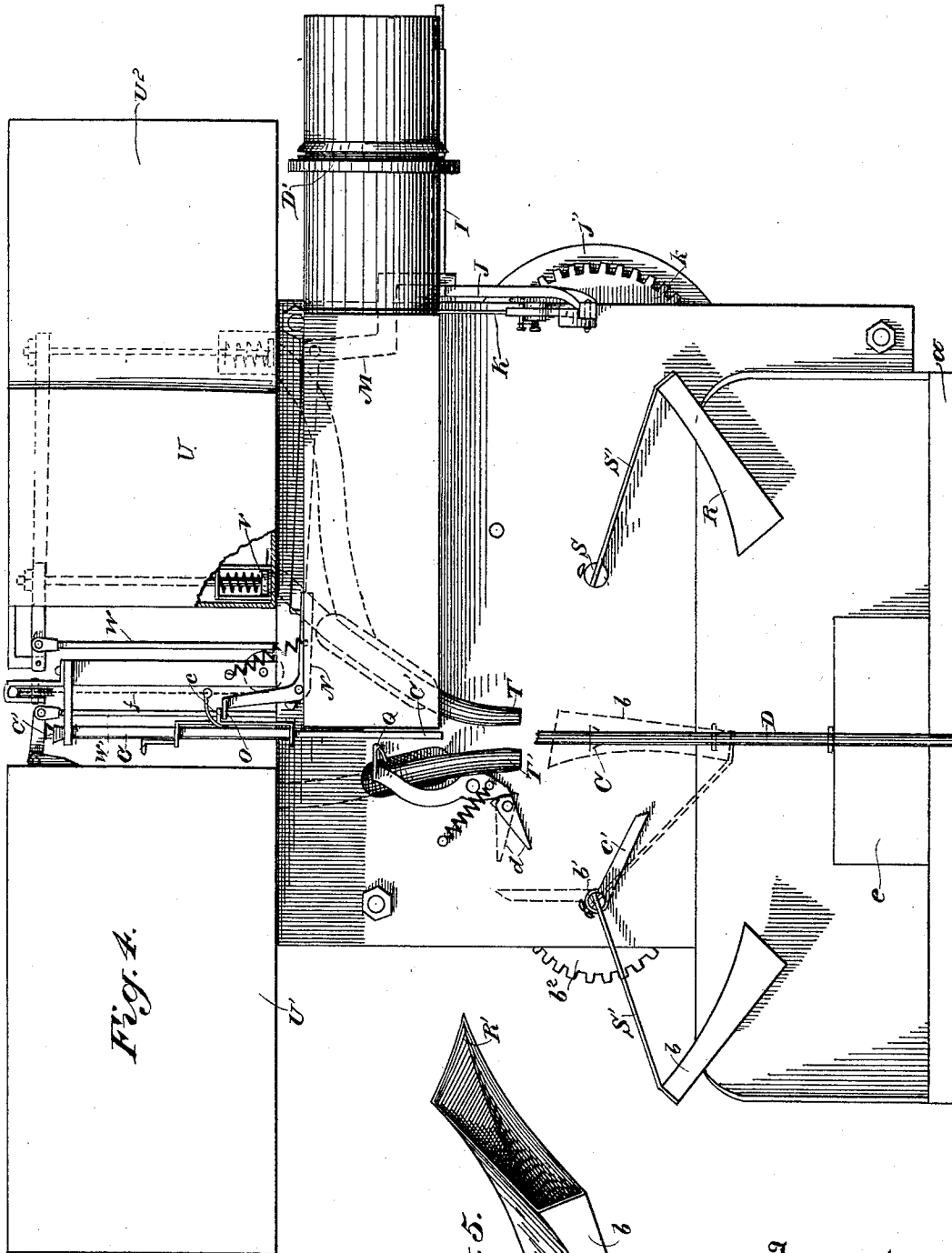

Fig. 4.

Fig. 5.

Witnesses,
G. H. Morse
H. F. Aschbeck

Inventor
Eugene J. Gregory
By Dwyer & Co.
attor

(No Model.)

4 Sheets—Sheet 4.

E. J. GREGORY.
AUTOMATIC PHOTOGRAPHIC CAMERA.

No. 544,669.

Patented Aug. 20, 1895.

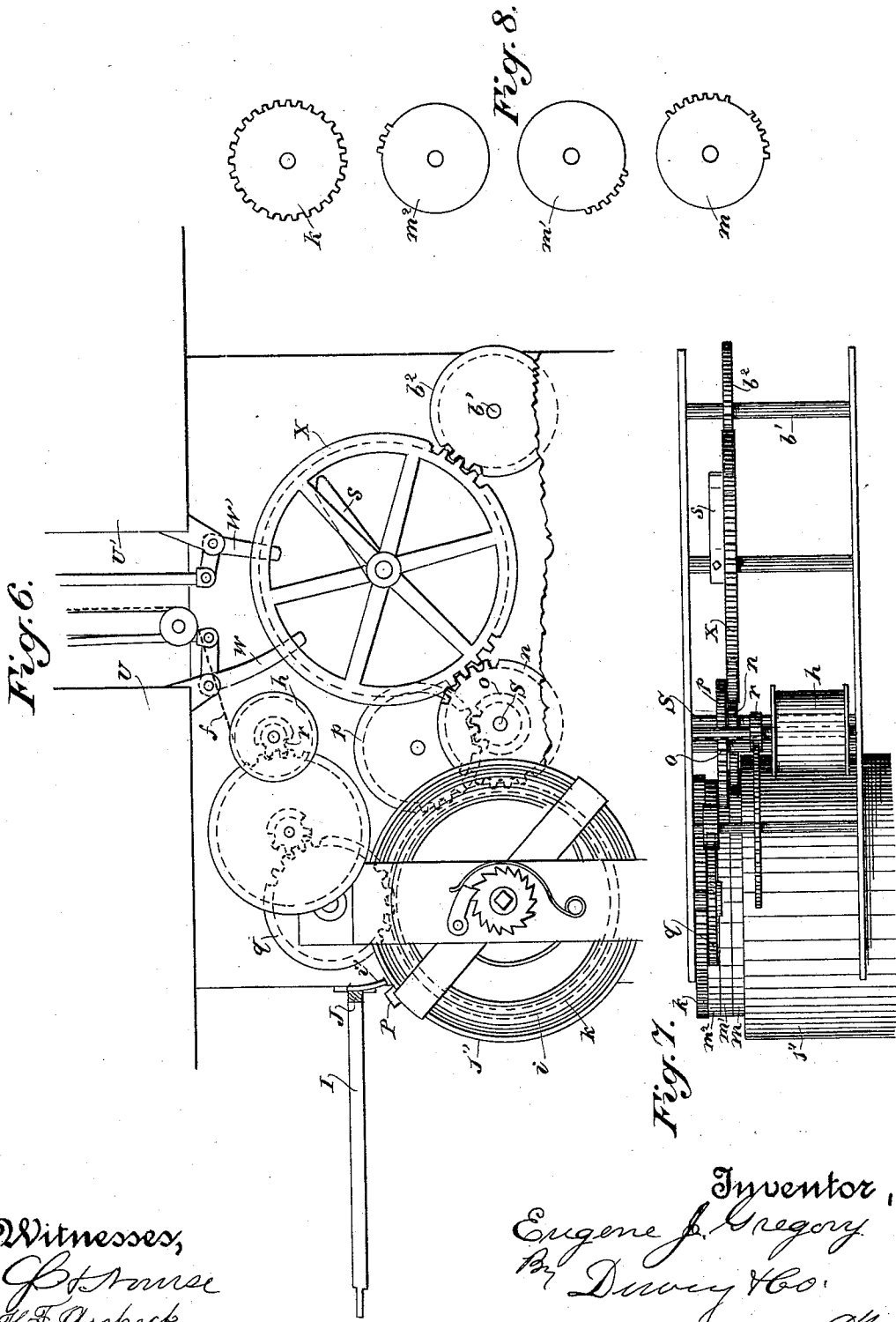

Witnesses,
G. H. Morse
H. F. Ascheck

Inventor,
Eugene J. Gregory
By *Dewey & Co.* *att*

UNITED STATES PATENT OFFICE.

EUGENE J. GREGORY, OF SACRAMENTO, CALIFORNIA.

AUTOMATIC PHOTOGRAPHIC CAMERA.

SPECIFICATION forming part of Letters Patent No. 544,669, dated August 20, 1895.

Application filed November 1, 1894. Serial No. 527,669. (No model.)

To all whom it may concern:

Be it known that I, EUGENE J. GREGORY, a citizen of the United States, residing in Sacramento, county of Sacramento, State of California, have invented an Improvement in Automatic Photographing-Cameras; and I hereby declare the following to be a full, clear, and exact description of the same.

My invention relates to an apparatus which is designed to take and finish photographs instantaneously and automatically. It is especially designed for the purpose of placing identifying photographs directly upon railway-tickets, letters-of-credit, and other papers in which it is desirable or necessary to have the user of the tickets or papers identified. It may also be used for secret service, newspaper and other work and for photographing views, buildings, &c. It may also be employed in conjunction with any well-known coin-actuated mechanism whereby a picture may be taken and delivered directly to the party desiring it without other manipulation than can be effected by the apparatus itself.

It consists in certain details of construction, which will be more fully explained by reference to the accompanying drawings, in which—

Figure 1 is an exterior view of the apparatus. Fig. 2 is a view of the carrier and slide. Fig. 3 is an end elevation with the outer casing removed. Fig. 4 is a side elevation. Fig. 5 is a view of the fixing-bath. Fig. 6 is a view of the gearing, taken from the side opposite to Fig. 4. Fig. 7 is a plan view of the gearing. Fig. 8 is a view of the mutilated gears separated from each other.

The object of my invention is to provide a paper ticket or card, one portion of which is adapted to receive printed, written, or other matter, and another portion of which is sensitized, so as to be capable of receiving a direct positive photographic picture, and a mechanism by which the operation of taking, developing, fixing, washing, and preparing the picture for delivery is automatically conducted.

In carrying out my invention I employ a closed case A, of any suitable or desired form, having at any convenient point a slotted opening B, which allows of the introduction of a carrier C' into a holder C, and this holder is

adapted to travel between vertical guides D, situated within the case.

The ticket, card, or other paper upon which the photograph is to be produced is specially prepared, one portion being adapted to receive written or printed matter of any description and the other end being properly prepared or sensitized to admit of a picture being taken and finished directly upon it, not as a negative, but as a positive finished picture.

In the present case I have shown the device as adapted to contain a ticket similar to a railroad-ticket and having a sliding plate C², which travels in grooves and is movable longitudinally in the carrier C'. This slide-plate normally remains at the bottom of the carrier C' and covers the sensitized portion of the paper upon which the picture is to be taken while in its normal condition. These carriers may be cheaply made, and each one put up with its inclosed ticket all ready for use and so constructed that they may be thrown away after the picture has been properly finished and removed from the apparatus, or they may be made of permanent materials, so that each ticket can be slipped into a holder in readiness for use.

The ticket is introduced through the slotted opening B and the edges of the opening are protected by any flexible fabric which will yield sufficiently to allow the holder or carrier to pass, but will close against its edges and sides so that the interior of the apparatus will remain light-tight. When the carrier is introduced into the holder C and pushed down, the upper edge of the slide C², being properly constructed for that purpose, engages the top of the holder and is arrested, so that the carrier C' moves down far enough to expose the lower sensitized portion of the card within the case or camera.

By the movements of the machinery, to be hereinafter described, the holder is first retained so as to bring the sensitized surface into line with a lens D, which is properly fixed within the outer casing and focused, so that the person or object presented in front of it will be photographed upon the face of the card when the shutter is moved and the exposure made.

In order to provide a light which will be sufficient for the purpose of taking the picture, any of the usual or well known flash-light powders may be employed.

5 I have shown a holder E fixed to the exterior of the case adapted to contain the necessary amount of powder, and an igniting device by which it is burned at the instant when the shutter is opened. Various devices
10 may be employed for this purpose. In the present case I have shown a hammer F adapted to strike upon a cap so as to explode it and ignite the powder. This hammer is actuated by a spring G and is held raised above the
15 cap by means of a trigger H. This trigger is actuated simultaneously with the movement of the shutter by means of a lever-arm I which projects through the side of the case, so that its outer end acts to disengage the trigger when moved. The inner end of the arm
20 I is fixed to a sliding-bar J which extends out through the side of the case, so that its outer end may be seized by the operator and pulled outward. The inner end connects through appropriate lever mechanism, a desirable form of which is shown at J⁵, with the shutter K, so that when the slide is pulled outwardly it opens the shutter and simultaneously pulls the trigger, allowing the hammer to fall and
30 ignite the powder, so as to produce a sufficient light upon the object to be photographed. The shutter being opened and the sensitized portion of the card brought into line with the axis of the lens, the picture will be taken upon
35 the surface. The shutter is then closed, as by the return of the slide or by a spring 20 so that the proper amount of exposure is had and the light immediately cut off. The slide carrying the card is at the same instant released at the completion of the pull upon the
40 slide J by the action of an inclined or cam-shaped lug *j* fixed upon the inner end of the slide J and adapted to engage a lever M. This lever acts upon a bell-crank lever N, which carries a stop O, and this stop engages a lug
45 *c* upon the sliding holder C, so as to retain it at first in the position to receive the carrier while the latter is being introduced. When the slide-rod J is pulled out it operates the
50 flash-light, and as the shutter instantly closes, the completion of the movement of the rod J causes the cam *j* to engage the lever M and through its connections to release the holder C and allow it to drop to the second position, where it is in readiness to be operated upon
55 by the developing-bath. It is arrested in this position by a suitable stop Q, operated as will be hereinafter described.

60 The developing-bath R consists of an approximately rectangular tank closed on the sides, ends, and bottom, and open upon one edge, which, when it is in proper position, becomes the top. This open end is made divergent, as shown, so that the developing-bath
65 may be moved up and inclose that portion of the card having the picture upon it without touching the card. This movement is pro-

duced by means of a shaft S, moved by mechanism to be hereinafter described, and an arm
70 S' connecting the shaft with the developing-bath R. The card being in the position last described, the mechanism acts to rotate the bath R from a position in which it is withdrawn from the line of travel of the card-carrier to a vertical position, in which it incloses
75 the lower part of the card. When it reaches this position, it becomes stationary by the operation of the mechanism, and is then filled with the developing-liquid from a pipe T, which leads from a tank U in the upper part
80 of the casing to such a point that when it is open it will discharge liquid into the developing-bath until the latter is sufficiently filled. The pipe T is controlled by a valve V, and this valve is opened by means of a lever W,
85 operated from the aforesaid mechanism, and is allowed to close when the bath is sufficiently filled. The bath remains in this position with the photographic impression immersed in the developing-liquid for a sufficient time
90 to properly develop the picture. As soon as the proper time has elapsed the mechanism, continuing to act, will withdraw the bath, rotating it about its carrying-shaft S, and as it returns to its normal position the contents
95 will flow out through an angularly-formed spout R' projecting from one corner of the bath in such a manner that the liquid will flow from it into a receiving-tank *a* situated in the lower part of the casing, from which it
100 may be discharged. While this bath is moving backward to its normal position a second bath *b*, constructed in a similar manner and carried by a rotary shaft *b'*, is gradually
105 brought into a vertical position, where it incloses the photographic picture. This bath is filled at the proper time from a tank U' by the opening of a valve operated by a lever W from the driving mechanism, the liquid flowing
110 from it through a pipe T', which discharges into this bath and fills it in the same manner that the bath R was filled. This bath contains the fixing solution, and as soon as it has performed its office it is again retracted by the action of the driving mechanism and
115 the liquid contained by it is poured out of a corner spout in the same manner that the bath R was emptied, the contents falling into the same receiving-tank and being conveyed away. As this bath *b* returns to its normal
120 position, the shaft *b'* which carries it acts through a lever-arm *c'* and an intervening latch *d* to tilt the lever-stop Q and again release the sliding carrier C, which now allows the end of the card with the picture upon it
125 to be plunged into a washing-tank *e*, situated between the guides and at the bottom of the case. Within this bath the picture is properly washed, and after the washing is completed the slide and carrier are raised to the top of
130 the casing by means of a cord *f* passing over a pulley *g*, and thence leading over proper direction-pulleys to a drum *h*, upon which it is coiled for the purpose. When the sliding

holder has thus been raised to its highest position, it is again allowed to rest upon the stop O, and the sliding carrier C' is withdrawn and the picture may be passed between rubbers or surfaces which will assist to dry it. The rapid drying of the picture may also be assisted by the use of alcohol into which it may have been passed, either while being washed or afterward, so that the rapid evaporation of the alcohol will assist in drying the card and making it ready to be delivered. The card is then in readiness to be removed from its carrier, and if anything is to be written upon the opposite end it is completed in the proper manner and ready to be delivered to the one for whom it is intended.

The movement of the various portions of the apparatus at the proper time may be effected in many different ways which will be obvious to a mechanic, and I do not wish to confine myself to any special mechanism for producing these various movements. In the present case I have shown a train of gearing actuated by a spring *i* coiled within and operating a barrel *j'*. Upon the shaft of this barrel is a gear-wheel *k*, which acts through a suitable train of gearing to drive a fan *l*, which acts as a regulator for the speed of the machinery. Upon the same shaft are fixed the mutilated gear-wheels *m m' m²*. The mutilated gear-wheel *m* engages the pinion *n*, which is fixed upon the shaft S, by which the bath R is actuated, and turning this pinion it rotates the shaft to bring the bath into the vertical position required for developing the picture. The shaft *b*, which carries the fixing-bath *b*, also has a corresponding pinion *b²* upon it, and by means of an intermediate gear-wheel *x* the two are actuated simultaneously, so that as the developing-bath is brought into vertical position to submerge the picture, the fixing-bath is correspondingly moved out of the way. The mutilated gear *m* passes out of engagement with this pinion *n*, and the gearing *b²* and the intermediate gear X remains stationary during a period which it is desired to submerge the picture in the developing-bath. When this period has elapsed the gear *m'* engages a pinion *p*, and this, acting upon a pinion *o* on the same shaft with the pinion *n*, reverses the direction of rotation of these shafts and thus retracts the developing-bath and rotates the fixing-bath into a position to submerge the picture within it. The set of teeth upon the mutilated gear *m* again engaging the pinion *n* rotates these connected gears X and *b²* and again returns the baths R and *b* to their normal position upon each side of the vertically-moving carrier. During this last operation of the movement, the carrier being released, as previously described, has dropped the picture into the washing-bath, and after the washing is completed the mutilated gear *m'* engages the teeth of a wheel *q*, and this, acting upon the pinion *r* of the winding-drum *h*, actuates the latter and raises the carrier to its position in the upper part

of the case. There being but few teeth in the mutilated gear *m* they soon pass out of engagement with the gear which they actuate, and thus allow these parts to again come to a state of rest.

The valves by which the developing and fixing solutions are respectively discharged into their baths when the latter are in the proper position are actuated by a cam-lever *s*, which, during the rotation of the wheel *o'*, alternately engage the levers by which the valves are opened, and are disengaged in time to allow the valves to close when the baths have become filled.

The parts are brought to a state of rest after each revolution of the barrel *j'* by a stop P, which engages a lug *i'* upon the bar J. In order that the developing chemicals may be separated from each other to prevent too rapid decomposition I may use a third tank U², in which event the said tank will be provided with a suitable valve actuated simultaneously with the valve V, whereby the chemicals of the tanks U and U² will be discharged in proper proportions into the tube T and thence into bath R.

Having thus described my invention, what I claim as new, and desire to secure by Letters Patent, is—

1. In an automatic photographic apparatus, a vertically moving slide, a carrier fitting within said slide adapted to contain a card or ticket, the lower end of which is sensitized, a slide in the carrier by which the sensitized end of the ticket is normally covered and protected, and a catch by which said slide is withdrawn from the sensitized portion when the carrier is introduced into the slide.

2. In an automatic photographic apparatus, a vertically moving slide and carrier within which the sensitized card or ticket is inclosed, a case within which the apparatus is inclosed, a slotted opening for the introduction of the carrier having flexible light tight flaps which normally close the opening, but which yield so that the carrier may be introduced into the slide while the flexible flaps prevent the entrance of light.

3. In an automatic photographic apparatus, a vertically moving slide, a carrier fitting said slide and adapted to contain a card or ticket, the lower end of which is sensitized, a sliding plate movable in the carrier, normally covering the sensitized portion of the card and a catch by which the plate is withdrawn to expose said portion when the carrier is introduced into the slide, a stop by which the slide is retained in the upper part of the apparatus until the carrier has been introduced, and mechanism by which it is released from the stop and allowed to drop out of line with the object lens fixed in the exterior casing.

4. In an automatic photographic apparatus, a slide and carrier adapted to contain a partially sensitized card or ticket, with a means for exposing the sensitized portion thereof, a casing within which the slide and carrier are

vertically movable, an object lens fixed in the casing with its axis intersecting the line of travel of the sensitized card, a shutter by which the lens or camera tube is normally closed, a stop by which the slide and carrier are retained in the upper part of the casing, a transversely movable slide bar and connections by which it moves the shutter when pulled out, and a cam by which the holding stop of the carrier is disengaged whereby the slide and carrier are allowed to drop after exposure, and a second stop upon which the slide and carrier are arrested.

5. In an automatic photographic apparatus, a vertically moving slide and carrier adapted to receive a card or ticket, the lower end of which is sensitized, a camera with shutter mechanism whereby it is operated to momentarily expose the sensitized paper so that a picture may be taken thereon, a releasing mechanism whereby the slide and carrier are dropped, and an arresting stop by which they are retained, a developing bath consisting of an open-ended containing vessel, mechanism whereby said bath is first moved upwardly so as to inclose the end of the card upon which the picture has been imprinted, a tank containing a developing solution, a pipe leading therefrom and discharging into the developing bath as the latter incloses the card, and a valve, and mechanism whereby the valve is opened to discharge a portion of the contents of the tank into the developing bath.

6. In an automatic photographic apparatus, the slide and carrier adapted to carry a sensitized card or ticket, a lens, the axis of which intersects the line of travel of the slide and carrier, an intercepting shutter and mechanism whereby it is withdrawn to expose the sensitized card for the purpose of taking a picture thereon, mechanism whereby the carrier and card are dropped and a stop by which they are arrested, a developing bath movable so as to first submerge the lower exposed end of the card therein, and a fixing bath movable to afterward submerge the card therein, and mechanism whereby the developing bath is first moved into position to submerge the card and is then withdrawn, and the fixing bath is in like manner moved into position to submerge the card, and is afterward withdrawn.

7. In an automatic photographic apparatus, a vertically moving slide and carrier adapted to contain a card or ticket, the lower end of which is sensitized, mechanism by which the sensitized portion of the card is exposed in a camera whereby a picture is imprinted thereon, mechanism whereby the carrier is moved downward, arrested and submitted to the successive action of a developing and a fixing bath, and mechanism whereby the slide and carrier are released when the fixing bath has been retracted, so as to allow the carrier to descend to the bottom of the case, and a washing bath into which the completed picture is thus plunged.

8. In an automatic photographic apparatus, a slide and carrier adapted to contain a card or ticket, the lower end of which is sensitized, a camera, a mechanism whereby the card is exposed so that a picture is taken thereon, vertically oscillating, developing and fixing baths, an interposed mechanism whereby the baths are moved alternately in opposite directions to submerge the end of the card containing the picture, a washing-bath into which the card is afterward plunged and washed, and a mechanism by which the slide and carrier are again elevated to the upper part of the inclosing casing so that the carrier with its finished picture may be removed therefrom.

9. In an automatic photographic apparatus, a slide and carrier adapted to contain a card or ticket, the lower end of which is sensitized, a camera and inclosing case within which the carrier moves vertically so as to intersect the axis of the camera lens, mechanism by which the card is exposed so that a picture is taken thereon, after which the carrier is dropped to an arresting stop, a developing bath supported from a rotary shaft so as to be partially revolved around the shaft whereby it is moved in an arc of a circle in a vertical plane so as to submerge the end of the card therein, and afterward withdrawn in the arc of a circle and become inverted so as to discharge itself and be out of line of travel of the card and ticket.

10. In an automatic photographic apparatus, a slide and carrier adapted to contain a card or ticket, the lower end of which has been sensitized, and a mechanism whereby the same is exposed within a closed case, mechanism whereby the carrier and card are dropped and arrested in proper position, a rotating shaft with a developing bath supported therefrom so as to oscillate in an arc of a circle whereby the card is first submerged in the bath, and the bath then retracted, a fixing bath mounted upon the opposite side of the line of travel of the card-carrier, and supported from a rotary shaft so as to oscillate in an arc of a circle, whereby it is brought into position to submerge the card after the developing bath has been retracted, and is then, itself, retracted out of the line of travel of the carrier.

11. In an automatic photographic apparatus, the vertically moving slide and carrier adapted to contain a card or ticket, the lower end of which has been sensitized, and mechanism whereby the card is exposed within a closed case, afterward alternately inclosed in developing and fixing baths, mechanism by which said baths are moved in arcs of circles alternately from opposite sides of the line of travel of the carrier whereby each bath is first brought into position to inclose the card, supply tanks and pipes with valves and mechanism to open said valves so that each bath is respectively filled after it has reached the position to inclose the card, said baths having

spouts formed upon their corners whereby they are discharged when they again oscillate out of the line of travel of the card carrier, and a washing tank into which the card is afterward dropped, a receiver surrounding said tank into which the angular spouts of the developing and fixing baths discharge exterior to the washing bath.

12. In an automatic photographic apparatus, a vertically moving slide and carrier adapted to contain a card or ticket, the lower end of which is sensitized, a camera and lens, the axis of which intersects the line of travel of the carrier, a shutter by which the camera is normally closed, a transversely moving sliding bar and intermediate mechanism by which the shutter is actuated so as to expose the card for the purpose of taking a picture thereon, a containing tray fixed to the exterior casing adjacent to the lens, adapted to hold a light producing substance, a spring-actuated hammer by which the cap is exploded to ignite the powder or substance, a trigger by which the hammer is held in position when withdrawn, and an arm projecting from the sliding bar adapted to engage the trigger and release the hammer at the instant when the sliding bar is withdrawn and the shutter opened.

13. In an automatic photographic apparatus, a vertically moving slide and carrier adapted to contain a card or ticket, the lower end of which is sensitized, a camera and an inclosing case within which the card and carrier are movable, and a movable shutter, mechanism whereby the shutter is opened to expose the card for the purpose of taking a picture thereon, and developing and fixing baths movable so as to alternately submerge

the ticket therein while the latter remains in a stationary position.

14. In an automatic photographic apparatus, a vertically moving slide and carrier adapted to contain a card or ticket, the lower end of which is sensitized, an inclosing casing within which the card and carrier move vertically, a camera the shutter of which is movable to expose the card so that a picture may be taken thereon, developing and fixing baths movable with relation to the card so as to alternately submerge it in these baths, mechanism by which the baths are moved consisting of a train of gearing with actuating spring or weight, mutilated gears or cams whereby the developing and fixing baths are alternately moved to submerge the card and then caused to move out of line of travel of the card and empty themselves.

15. In an automatic photographic apparatus, a vertically moving carrier adapted to contain and expose a ticket or card having a portion of its surface sensitized, to the action of a camera lens, developing and fixing baths movable in arcs of circles whereby the card is successively submerged in them, supply tanks containing solutions to be supplied to the baths when in position, with conveying pipes and controlling valves, a cam or lever fixed upon a rotating shaft, and gearing whereby said cam is moved to open and close the valves.

In witness whereof I have hereunto set my hand.

EUGENE J. GREGORY.

Witnesses:

T. WALTER FOWLER,
S. A. TERRY.