



Europäisches Patentamt  
European Patent Office  
Office européen des brevets



(11) **EP 1 370 367 B1**

(12) **EUROPEAN PATENT SPECIFICATION**

(45) Date of publication and mention  
of the grant of the patent:  
**29.06.2005 Bulletin 2005/26**

(51) Int Cl.7: **B05B 7/10**, B05B 1/00,  
B05B 7/00

(21) Application number: **02720694.5**

(86) International application number:  
**PCT/RU2002/000108**

(22) Date of filing: **21.03.2002**

(87) International publication number:  
**WO 2002/076624 (03.10.2002 Gazette 2002/40)**

(54) **LIQUID SPRAYERS**  
FLÜSSIGKEITSZERSTÄUBER  
PULVERISATEURS DE LIQUIDE

(84) Designated Contracting States:  
**AT BE CH CY DE DK ES FI FR GB GR IE IT LI LU  
MC NL PT SE TR**  
Designated Extension States:  
**AL LT LV MK RO SI**

(72) Inventors:  
• **Dushkin, Andrey L.**  
**Moskow 105187 (RU)**  
• **Karpyshev, Alexander V.**  
**Moscow 129272 (RU)**

(30) Priority: **22.03.2001 RU 2001107433**

(74) Representative: **Hano, Christian, Dipl.-Ing. et al**  
**v. Fünér Ebbinghaus Finck Hano**  
**Mariahilfplatz 2 & 3**  
**81541 München (DE)**

(43) Date of publication of application:  
**17.12.2003 Bulletin 2003/51**

(73) Proprietor: **Velzen Holdings Limited**  
**Road Town, Tortola (VG)**

(56) References cited:  
**DE-A- 3 622 292**                      **US-A- 3 701 482**  
**US-A- 4 134 547**                      **US-A- 4 341 347**  
**US-A- 4 644 974**                      **US-A- 5 275 763**

**EP 1 370 367 B1**

Note: Within nine months from the publication of the mention of the grant of the European patent, any person may give notice to the European Patent Office of opposition to the European patent granted. Notice of opposition shall be filed in a written reasoned statement. It shall not be deemed to have been filed until the opposition fee has been paid. (Art. 99(1) European Patent Convention).

## Description

**[0001]** The invention relates to the liquid spraying technique and may be used in fire-prevention systems, as part of processing equipment, for the burning of fuels in the heat engineering and transport, as well as for humidifying the environment and for spraying disinfectants and insecticides.

### *Background of the invention*

**[0002]** Diversified types of liquid sprayers are currently used in a variety of fields, including the fire-fighting equipment, as fire-extinguishant sprayers.

**[0003]** As an example, the Patent US No 5125582 (IPC B05B 1/00, published 30.06.1992) discloses the construction of a liquid sprayer designed for the generation of cavitation liquid flows. The prior art comprises a casing with a flow-through channel formed by a nozzle and a cylindrical chamber. The nozzle is made in the form of a converging tube communicated with a conical diffuser without continuous joining of their surfaces. A length of the cylindrical chamber is at least three diameters of a minimal section of the nozzle. On supplying the liquid under pressure into the inlet opening of the converging tube of the nozzle, the liquid flow section is contracted and the outflow velocity is increased. An abrupt expansion of the liquid flow in the diffuser results in liquid cavitation. The liquid cavitation is intensified in the process of passage of the liquid jet through the cylindrical chamber, where the liquid jet is expanded and return vortex flows are generated. An annular vacuum zone is formed around a conical jet to initiate a cavitation process and an associated liquid flow dispersion process.

**[0004]** However, despite the possibility of an intensified cavitation process, the prior art liquid sprayer does not provide for the formation of a steady-state fine-dispersed liquid flow, that can retain its shape and section size at the distances of up to 10 m, which is of particular importance when the sprayer is employed for suppressing the sources of fire.

**[0005]** A vacuum-type sprayer head (the author's certificate, USSR, No 994022, IPC B05B 1/00, published 07.02.1983) is also known, which comprises a nozzle composed of a converging tube and a cylindrical head located coaxial with the nozzle. The cylindrical head is equipped with ejection holes formed at the side of its outlet opening to admit atmospheric air into a vacuum zone in the cylindrical head cavity. As a result the incoming air saturates the moving liquid flow to provide for splitting of the flow into small droplets.

**[0006]** Russian Patent No 2123871 (IPC A62C 31/02, published 27.12.1998) describes a head for forming an aerosol-type water spray, which allows the dispersion of a gas-drop jet to be improved. The prior art sprayer (head) comprises a casing having a flow-through channel formed as a Laval nozzle, an inlet pipe union for sup-

plying liquid under pressure, and a distributing grid located between the pipe union and an inlet section of the Laval nozzle. The sizes of the distributing grid holes are  $0.3 \div 1.0$  the diameter of the Laval nozzle critical section. While passing through the holes of the distributing grid, the liquid flow is split into separate streams, which are sequentially concentrated in the nozzle orifice and accelerated to high velocities. Such embodiment provides for a sufficient distance of discharging a fire extinguishant and fine spraying.

**[0007]** The closest analog for the claimed versions of the sprayer is a liquid spraying device described in the Patent DDR No. 233490 (IPC A62C 1/00, published 05.03.1986), which is adapted for feeding a fire-extinguishant to a source of fire. The device is composed of a casing involving a flow-through channel, into which a working fluid, including water, is supplied under pressure. The flow-through channel of the device is composed of an inlet portion formed as a converging tube, a cylindrical portion and an outlet portion formed as a conical diffuser, said portions being sequentially joined with one another in axially aligned relationship. Also, the device comprises a reservoir containing a fire-extinguishant, which is communicated with the diffuser via radial passages.

**[0008]** During operation of said device the liquid (water) is supplied under the pressure of  $1.5 \div 2.0$  bar into the inlet opening of the flow-through channel and is sequentially accelerated in a nozzle formed by the converging tube, the cylindrical portion and the diffuser. The fire-extinguishant is ejected into the diffuser through the radial passages to be further intermixed with the liquid flow. The implementation of said device allows the reach of the fire-extinguishant to be essentially increased to thereby improve the fire-fighting effectiveness, when known extinguishants are utilized. However, the given embodiment does not provide for the generation of high-velocity fine-dispersed gas-drop jets. The liquid flow is used in such devices for the most part as a carrier for an additionally introduced fire-extinguishant, for example, for foam-generating additives.

### *Disclosure of the invention*

**[0009]** The claimed invention is aimed at generating a steady-state fine-dispersed liquid spray, which must retain the shape and size of its section at the distances of up to 10 m, and at increasing the efficiency of energy consumed for the generation of a gas-drop jet. Also the distribution of drop concentration over the section of a fine-dispersed gas-drop jet must be homogeneous. The solution of the aforesaid objectives is of particular importance in the implementation of liquid sprayers for suppressing the sources of fire.

**[0010]** The technical result which may be achieved through the solution of the tasks set forth consists in increasing the fire-fighting effectiveness, when water containing fire-extinguishing additives is used, in increasing

the effective utilization of a working fluid and in reducing the energy consumption for generating a gas-drop jet.

**[0011]** The aforesaid objectives are achieved by providing a liquid sprayer according to the first embodiment of the invention comprising a casing having a flow-through channel composed of an inlet portion formed as a converging tube, a cylindrical portion and an outlet portion formed as a conical diffuser, with said portions being sequentially joined with one another in axially aligned relationship (known from US-A-3701482), wherein, according to the present invention, a length of the cylindrical portion is not less than its radius, a cone angle of the diffuser defining the outlet portion of the flow-through channel is greater than a cone angle of the converging tube defining the inlet portion of the flow-through channel.

**[0012]** A liquid sprayer having an apex angle of a cone defining the converging tube between  $6^\circ$  and  $20^\circ$  and an apex angle of a cone defining the diffuser between  $8^\circ$  and  $90^\circ$  is preferably used. In particular, an apex angle of a cone defining the converging tube may be equal to  $13^\circ$  and an apex angle of a cone defining the diffuser may be equal to  $20^\circ$ .

**[0013]** To enhance the steady-state flow of the gas-drop jet so that it is free from stationary and oscillatory deviations from a predetermined orientation, inlet edges of the converging tube defining the inlet portion of the flow-through channel and outlet edges of the diffuser defining the outlet portion of the flow-through channel are formed rounded.

**[0014]** The radius of rounded edges is substantially  $1 \div 2.5$  the radius of the cylindrical portion of the flow-through channel.

**[0015]** The liquid sprayer may be equipped with a chamber having a cylindrical channel, whose inlet end is joined with an outlet section of the diffuser, with the diameter of the cylindrical channel of the chamber being not less than the diameter of the outlet section of the diffuser. The utilization of aforesaid chamber allows fine-spray fine-dispersed gas-drop jets to be generated at the minimal consumption of energy. A diameter of said cylindrical channel of the chamber is substantially  $4 \div 6$  diameters of the cylindrical portion of the flow-through channel, and a length of said channel is  $10 \div 30$  diameters of the cylindrical portion of the flow-through channel.

**[0016]** A grid or perforated plate may be located at the outlet section of the cylindrical channel of said chamber. In this event, the gas-drop jet generated in the cylindrical channel of the chamber is additionally split.

**[0017]** In order to reduce the losses of energy in the process of generating a fine-dispersed flow, a total cross-sectional area of the perforated plate or grid holes is selected to be  $0.4 \div 0.7$  of a cross-sectional area of the cylindrical channel of said chamber.

**[0018]** The chamber wall may be furnished with at least one tangential opening for ejecting gas (for example, air) from the outside into the cylindrical channel of

said chamber. Such embodiment allows the gas-drop jet to be stabilized and the losses of kinetic energy of liquid droplets to be reduced due to the swirling of the air flow around the jet generated. With this aim in view, the chamber wall of the preferred embodiment may be equipped with at least four tangential openings, which are symmetrically arranged by pairs in two cross-sectional planes of the cylindrical channel of said chamber, the first plane extending near the diffuser outlet section and the second plane extending near the outlet section of the chamber.

**[0019]** According to another preferred embodiment, a liquid sprayer may be comprised of a chamber arranged coaxial with a casing, on the outside thereof. At least one passage is formed between the casing outer surface and the chamber inner surface for supplying a gas flow under pressure toward the outlet section of the outlet portion of the flow-through channel of said sprayer. The chamber may contain a nozzle composed of a converging tube and a diffuser arranged in sequence. The nozzle inlet section is communicating with an outlet portion of the flow-through channel of said sprayer. The use of the chamber with the nozzle allows the energy of a cocurrent gas flow to be utilized for further splitting of liquid drops and for increasing the reach of the fine-dispersed gas-drop jet.

**[0020]** The accomplishment of said objectives is also enabled by providing a liquid sprayer which according to the second embodiment of the invention includes a casing having a flow-through channel composed of an inlet portion formed as a converging tube, a cylindrical portion and an outlet portion formed as a conical diffuser, with said portions being joined with one another in axially aligned relationship, wherein according to the present invention a length of the cylindrical portion is not less than a radius thereof, and the converging tube defining the inlet portion of the flow-through channel is made conoid-shaped, with a radius of roundness of the side surface being not less than a radius of the cylindrical portion of the flow-through channel.

**[0021]** The apex angle of a cone forming the diffuser is preferably between  $8^\circ$  and  $90^\circ$ . The surface of the conoid-shaped converging tube is joined with the surface of the cylindrical portion of the flow-through channel preferably at an angle not in the excess of  $2^\circ$ .

**[0022]** To further stabilize the steady-state flow of a gas-drop flow, outlet edges of the diffuser defining the outlet portion of the flow-through channel are made rounded. The radius of roundness of the edges is substantially  $1 \div 2$  the radius of the cylindrical portion of the flow-through channel.

**[0023]** The liquid sprayer may be furnished with a chamber having a cylindrical channel, whose inlet end is joined with an outlet section of the diffuser, a diameter of the cylindrical channel of the chamber being not less than a diameter of the outlet section of the diffuser. The utilization of said chamber, as in the first embodiment of the invention, allows fine-spray fine-dispersed gas-drop

jets to be generated at the minimal energy consumption. A diameter of the cylindrical channel of the chamber is substantially 4 ÷ 6 diameters of the cylindrical portion of the flow-through channel, and its length is 10 ÷ 30 diameters of the cylindrical portion of the flow-through channel.

**[0024]** A grid or perforated plate may be located in the outlet section of the cylindrical channel of the chamber, as in the first embodiment of the invention. In order to reduce the losses of energy during generation of fine-dispersed flow, the total cross-sectional area of the perforated plate or grid holes is selected to be equal to 0.4 ÷ 0.7 the cross-sectional area of the cylindrical channel of said chamber.

**[0025]** The chamber wall, as in the first embodiment of the invention, may be furnished with at least one tangential opening for ejecting gas from the outside into the cylindrical channel of the chamber. Such embodiment allows the gas-drop jet to be stabilized and the losses of kinetic energy of liquid flows to be reduced due to swirling of the air flow around the flow generated. With this aim in view, the chamber wall in the preferred embodiment of the invention may be equipped with at least four tangential openings, which are symmetrically arranged by pairs in two cross-sectional planes of the cylindrical channel of said chamber, the first plane extending near the outlet section of the diffuser and the second plane extending near the outlet section of said chamber.

**[0026]** Also the preferred embodiment of the liquid sprayer may contain a chamber arranged coaxial with the casing on the outside thereof instead of the above described chamber. At least one passage is formed between the outer surface of the casing and the inner surface of the chamber for supplying gas under pressure to the section of the outlet portion of the flow-through channel of said sprayer. The chamber may comprise a nozzle composed of a converging tube and a diffuser arranged in sequence. The nozzle inlet section is communicating with the outlet portion of the flow-through channel of said sprayer. The implementation of the chamber with the nozzle allows, as in the first embodiment of the invention, the energy of a cocurrent gas flow to be utilized for further splitting of liquid droplets and increasing the reach of the fine-dispersed gas-drop flow.

#### *Brief description of the drawings*

**[0027]** The invention is explained by the examples of a particular embodiment and by the applied drawings describing the following:

Fig. 1 is a schematic representation of the liquid sprayer formed in accordance with the first embodiment of the invention;

Fig. 2 is a schematic sectional view of the liquid sprayer formed in accordance with the first embodiment of the invention with rounded edges of the flow-through channel;

Fig. 3 is a schematic sectional view of the liquid sprayer formed in accordance with the first embodiment of the invention with a chamber having a cylindrical channel;

Fig. 4 is a sectional view in the plane A-A of the chamber equipped with a cylindrical channel and used in two embodiments of the invention (See Figs 3 and 6);

Fig. 5 is a schematic sectional view of the liquid sprayer formed in accordance with the first embodiment of the invention with the chamber located coaxial with a casing so that an annular passage is formed;

Fig. 6 is a schematic representation of the liquid sprayer formed in accordance with the second embodiment of the invention.

Fig. 7 is a schematic sectional view of the liquid sprayer equipped in accordance with the second embodiment of the invention with a chamber having a cylindrical channel;

Fig. 8 is a schematic sectional view of the liquid sprayer equipped in accordance with first embodiment of the invention with a chamber arranged coaxial with a casing so that an annular passage is formed.

#### *Preferred examples of embodiments of the invention*

**[0028]** A liquid sprayer formed according to the first embodiment of the invention (See Figs 1 to 5) comprises a casing 1 with a flow-through channel composed of axially aligned portions joined with one another. An inlet portion 2 is made in the form of a converging tube with an outlet opening joined to an inlet opening of a cylindrical portion 3. An outlet portion 4 made in the form of a conical diffuser comprises an inlet opening joined with an outlet opening of the cylindrical portion 3. A length of the cylindrical portion is 0.7 the diameter thereof. An apex angle of a cone defining the converging tube is 13° and an apex angle of a cone defining the diffuser is 20°.

**[0029]** The casing 1 is connected at the side of the inlet opening of the converging tube to a pipe union 5 of a pipeline of a liquid supply system. The liquid supply system includes a pump- or pressure-type liquid supercharger 6.

**[0030]** In a preferred embodiment (See Fig. 2) inlet edges of the converging tube defining the inlet portion 2 of the flow-through channel and outlet edges of the diffuser defining the outlet portion 4 are made rounded, with the radius of roundness being equal to the diameter of the cylindrical portion 3.

**[0031]** The liquid sprayer may include a chamber 7 (See Fig. 3) having a cylindrical channel 8 whose inlet opening is communicating with an outlet section of the diffuser (outlet portion 4). A diameter of the cylindrical channel 8 is equal to four diameters of the cylindrical portion 3 of the flow-through channel. The length of the cylindrical channel 8 measured from the outlet section

of the diffuser to the outlet section of the chamber 7 is equal to ten diameters of the cylindrical portion 3 of the flow-through channel. A perforated plate 9 is located in the outlet opening of the cylindrical channel 8 and attached to an end part of the chamber 7 by means of a special nut 10. A total cross-sectional area of holes in the perforated plate 9 is 0.5 the cross-sectional area of the cylindrical channel 8. The maximal size "d" of each of the flow-through holes in the perforated plate 9 is selected depending on the diameter "D" of the cylindrical portion 3 in accordance with the condition:  $0.2 < d/D < 0.7$ .

**[0032]** Eight tangential openings 11 are formed in the wall of chamber 7 for ejecting air from the outside into the cylindrical channel 8 (See Figs 3 and 4). The tangential openings 11 are arranged in two cross-sectional planes of the cylindrical channel 8. Four openings 11 are symmetrically arranged in the cross-sectional plane of the channel 8 near the outlet section of the diffuser (outlet portion 4), and four other openings 11 are arranged in the cross-sectional plane of the channel 8 near the outlet section of the chamber 7.

**[0033]** The sprayer may be equipped with a cylindrical chamber 12 (See Fig. 5) arranged in axial alignment with the casing 1, on the outside thereof. An annular passage is formed between the outer surface of the casing 1 and the inner surface of the chamber 12 and communicated with a high-pressure gas source 13. The annular passage is adapted for supplying gas to the section of the outlet portion 4 of the flow-through channel. A nozzle located on an end part of the chamber is composed of a converging tube 14 and a diffuser 15.

**[0034]** A liquid sprayer, according to the second embodiment of the invention (See Figs 6 to 8), comprises a casing 16 with a flow-through channel composed of sequentially joined portions axially aligned with one another. An inlet portion 17 is made in the form of a conoid-shaped converging tube with a radius of roundness of a side surface equal to the diameter of a cylindrical portion 18. A length of the cylindrical portion 18 joined with the inlet portion 17 is 0.7 the diameter thereof. An outlet portion 19 formed as a conical diffuser has an inlet opening joined with the outlet opening of the cylindrical portion 18. An apex angle of a cone forming the diffuser is  $20^\circ$ . The conoid-shaped surface of the converging tube (inlet portion 17) is joined with the surface of the cylindrical portion 18 at an angle of  $2^\circ$ . The outlet edges of the diffuser forming the outlet portion 19 of the flow-through channel are made rounded, with a radius of roundness of the edges being equal to that of the cylindrical portion 18.

**[0035]** The casing 16 is connected to a pipe union 20 of a pipeline of a liquid supply system including a liquid supercharger 21.

**[0036]** The outlet edges of the diffuser forming the outlet portion 19 are made rounded, with a radius of the roundness of the edges being equal to that of the cylindrical portion 18.

**[0037]** In the preferred embodiment of the sprayer (See Fig. 7) the outlet opening of the diffuser (outlet portion 19) is communicated with a chamber 22 having a cylindrical channel 23. Geometrical sizes of the cylindrical portion 18 are selected identical to those of the first embodiment of the sprayer (See Fig. 3). A perforated plate 24 is located in the outlet opening of the cylindrical channel 23 and attached to an end part of the chamber 22 by means of a special nut 25. The sizes of holes in the perforated plate 24 are selected identical to those of the first embodiment of the sprayer (See Fig. 3).

**[0038]** Eight tangential openings 26 are formed in the wall of the chamber 22 for ejecting air from the outside into the cylindrical channel 23 (See Figs 7 and 4). Tangential openings 26 are arranged and oriented in the manner identical to that of the first embodiment of the sprayer.

**[0039]** Another example of the sprayer according to the second embodiment of the invention may comprise a cylindrical chamber 27 (See Fig. 8) arranged coaxial with the casing 16, on the outside thereof. An annular passage formed between the outer surface of the casing and the inner surface of the chamber 27 is communicated with a high-pressure gas source 28. The annular passage is adapted for supplying a cocurrent gas flow to the outlet section of the outlet portion 19 of the flow-through channel. A nozzle on the end part of the chamber is composed of a converging tube 29 and a diffuser 30.

**[0040]** The operation of the sprayer designed in accordance with the first embodiment of the invention is carried out in the following manner.

**[0041]** Water is supplied under pressure by a supercharger 6 via a pipeline of a water supply system to a pipe union 5 connected to an outlet opening of the casing 1 of said sprayer. Water is delivered into an inlet opening of the converging tube (inlet portion 2), where a high-velocity liquid flow is generated with a uniform velocity profile over the section thereof. The liquid flow is advancing in the converging tube from the zone with a higher static pressure and a lower dynamic pressure to the zone with a lower static pressure and a higher dynamic pressure. This allows the conditions for the formation of vortex flows and separation of the liquid flow from the channel wall to be prevented.

**[0042]** The maximal liquid flow velocity at the outlet end of the converging tube is selected such that the static pressure at the outlet end of the converging tube is decreased to the value of the saturated liquid vapor pressure at the initial temperature (for water  $P_{sv} \approx 2.34 \cdot 10^{-3}$  MPa at  $t=20^\circ\text{C}$ ). The initial static water pressure upstream of the converging tube is maintained at the level not below the critical pressure sufficient for the development of cavitation during outflow into the atmosphere ( $P_{in} \approx 0.23$  MPa). The losses of kinetic energy occurring during passage of the liquid flow through the converging tube depend on the cone angle of a cone forming the conical surface of the converging tube. As

the cone angle increases from  $6^\circ$ , the consumption of energy is initially increased to reach the maximal value at the angle of  $\sim 13^\circ$  and is then decreased at the angle of  $\sim 20^\circ$ . The optimal apex angle of the cone forming the converging tube is therefore selected between  $6^\circ$  and  $20^\circ$ .

**[0043]** Upon passage through the inlet portion 2 of the flow-through channel of the sprayer, the liquid flow is delivered into the cylindrical portion 3, where cavitation bubbles are developed for the period of time of  $\sim 10^{-4} \div 10^{-5}$  s. The formation of bubbles during the passage of water flow through the cylindrical portion 3 is ensured in case the length of the cylindrical portion exceeds its radius to provide for predetermined time sufficient for the steady-state cavitation. However, it is well known that hydraulic friction losses are increased at substantially increased length of the cylindrical channel. So under the practicable sprayer service conditions the length of the cylindrical channel may be restricted to the value corresponding to a diameter of the flow-through channel.

**[0044]** During passage of the liquid through the outlet portion 4 formed as a diffuser the cavitation bubbles are intensively growing and clapping and the liquid flow is separated from the diffuser wall. The flow is accelerated in the diffuser due to the reduction in the density of the liquid flow containing vapor and air bubbles. Because the static pressure in an inlet zone of the diffuser is low and is comparable to the cavitation pressure, a directed air flow enters from the outside into a cavity between the gas-drop jet and the diffuser wall. Vortex flows resulting from the countercurrent gas flow and liquid flow force out the liquid flow from the diffuser wall to reduce the friction energy losses. Also the formation of vortex flows results in active splitting of the liquid flow, which is further intensified by clapping of the cavitation bubbles during the expansion of the flow in the diffuser. Such processes occur in case the cone angle of the diffuser defining the outlet portion 2 of the flow-through channel exceeds the cone angle of the converging tube defining the inlet portion 4 of the flow-through channel of the sprayer. Optimal apex angles of the cone forming the diffuser are between  $8^\circ$  and  $90^\circ$ . Formation of vortex flows does not occur at the apex angles exceeding  $90^\circ$ . At the apex angles less than  $8^\circ$  a gas blanket between the liquid flow and the diffuser wall is practically lacking.

**[0045]** Along with the proper selection of optimal taper angles for the converging tube and the diffuser, a diameter of the diffuser outlet opening is important for effective splitting of the liquid flow. It is advisable to use the diameter of the diffuser outlet opening exceeding the diameter of the cylindrical portion 3 by  $4 \div 6$  times. At a lesser diameter of the diffuser outlet opening the effect of vortex flows appears only slightly upon the liquid flow and at a greater diameter the dimensions of the sprayer are substantially increased.

**[0046]** The sprayer having the aforementioned sizes of the flow-through channel provides for the formation

of a high-velocity fine-dispersed gas-drop jet at the minimal losses of kinetic energy.

**[0047]** When the diameter of the outlet opening of the pipe union 5 is essentially greater than the diameter of the cylindrical portion 3 of the flow-through channel, use is made of a converging tube having rounded inlet edges (See Fig. 2).

**[0048]** Such embodiment of the sprayer allows its dimensions to be decreased with minimal losses of kinetic energy for friction and formation of vortex flows. Optimal radius of roundness of the converging tube edges is between 1 and 2.5 radius of the cylindrical portion of the flow-through channel. Increase in the radius of the rounded edges results in increased dimensions of the whole device, so the radius is preferably selected equal to the diameter of the cylindrical portion 3. With the liquid outflowing through the converging tube having rounded edges, the operational mode of the sprayer is not changed as a whole, the cavitation zones being localized in the inlet portion of the diffuser. The given operational feature intensifies cavitation in the liquid flow during acceleration thereof.

**[0049]** Implementation of the diffuser (outlet portion 4 of the flow-through channel) with rounded outlet edges (See Fig. 2) allows the steady state of the gas-drop jet flowing from the sprayer to be enhanced. With such embodiment of the sprayer, the jet generated is free from stationary and oscillatory deviations from a longitudinal axis of symmetry of the flow-through channel.

**[0050]** The radius of roundness of the diffuser outlet edges is also selected between 1 and 2.5 radius of the cylindrical portion 3 of the flow-through channel of said sprayer. An increase in the radius of roundness of the diffuser outlet edges results in the reduced effect of air vortex flows entering the diffuser on the process of splitting drops in the gas-drop jet generated. As a consequence, drop sizes in the gas-drop jet generated are increasing. On the basis of the aforementioned limitations, the radius of roundness of edges in the preferred embodiment is selected equal to the diameter of the cylindrical portion 3 of the flow-through channel.

**[0051]** On flowing of the accelerated liquid-gas jet through the outlet section of the diffuser having outlet edges rounded to the optimal extent, axially symmetric toroidal vortex air flows are formed in the diffuser. Such toroidal structures are axially elongated and do not give rise to disturbances in the diffuser outlet portion.

**[0052]** When a chamber 7 with a cylindrical channel 8 (See Fig. 3) is used in the preferred embodiment of the sprayer, the gas-drop jet is expanded and droplets are additionally split by the perforated plate 9. While advancing through the channel 8, the jet is expanded and becomes stabilized along the length of the channel which is 10 to 30 diameters of the cylindrical portion 3 of the flow-through channel of the sprayer. At the given range of lengths for the cylindrical channel 8, the velocity leveling is provided over the section of the gas-drop jet on the one hand and the required jet velocity is main-

tained on the other hand. Upon collision against the perforated plate 9, the size of droplets in the gas-drop jet is reduced on the average by  $2 \div 3$  times.

**[0053]** The effect of the perforated plate 9 on the structure of the gas-drop jet generated in the flow-through channel of the sprayer is eliminated by providing free access of air from the outside to the diffuser outlet section. Such possibility is provided through selecting a total area of holes in the plate 9 in the range between 0.5 and 0.6 of the cross-sectional area of the cylindrical channel 8. An increase in the area of holes results in non-uniform drop size distribution over a section of the fine-dispersed flow generated and in the possible occurrence of separate liquid streams and gas inclusions (discontinuities in the liquid flow) on the periphery of the flow.

**[0054]** The optimal selection of diameters "d" of holes in the perforated plate 9 (according to the condition:  $0.2 < d/D < 0.7$ , where D is the diameter of the cylindrical portion 3) provides for time and spatially uniform splitting of the liquid flow into small droplets. The selection of hole sizes less than the optimal values results in "sticking" of liquid in the perforated plate holes due to the effect of surface tension forces. On the other hand, an increase in the diameter "d" of holes above the optimal value results in an increase in the sizes of droplets in the liquid-gas flow generated.

**[0055]** Tangential openings 11 (See Fig. 3) formed in the chamber 7 provide for additional vortex stabilization in the process of formation of a fine-dispersed gas-drop jet, when the liquid feed pressure is varied within a wide range (up to tenfold increase of the initial nominal level).

**[0056]** During operation of the sprayer the air is ejected from the outside into the cylindrical channel 8 via four tangential openings 11, which are symmetrically arranged by pairs in two cross-sectional planes of the cylindrical channel 8 of the chamber 7. The ejection is caused by the reduction of the static pressure (vacuum) at the diffuser outlet end, when the gas-drop jet is accelerated. The tangential orientation of the openings 11 formed in the chamber 7 and their symmetric arrangement in the two cross-sectional planes of the chamber 7, with the first plane extending near the diffuser outlet section and the second plane extending near the outlet section of the chamber 7, allows the ejected air flow to be uniformly swirled around the gas-drop jet. Tangential swirling of the incoming air reduces the effect of the perforated plate 9 on the flow in the cylindrical channel 8 and minimizes "sticking" of the liquid in the holes of the perforated plate 9. Also, said operational mode of the sprayer intensifies the process of intermixing the liquid drops with air across the flow section and, consequently, increases the homogeneity of drop concentration in the flow upstream of the perforated plate 9. Along with this, the possibility for occurrence of separate liquid streams affecting the formation of a homogeneous fine-dispersed gas-drop jet is eliminated.

**[0057]** The investigations disclosed that the optimal

conditions for stabilizing a gas-drop jet are created by providing a certain ratio of the cross-sectional area of tangential openings to the total area of the effective section of the perforated plate 9, which is between 0.5 and 0.9. The number and arrangement of the tangential opening levels along the chamber 7 depend on the requirements for uniform mixing of the liquid-gas flow.

**[0058]** Use of a chamber 12 (See Fig 5) in the construction of the sprayer provokes further splitting of drops in the generated cocurrent gas flow and increases the reach of a fine-dispersed gas-drop jet generated. A gas flow is generated through the outflow of gas supplied under the excessive pressure of  $0.25 \div 0.35$  MPa from a high-pressure gas source 13 into an annular passage formed between the outer surface of the sprayer casing 1 and the inner surface of a chamber 12. The optimal ratio of the liquid flow rate through the sprayer flow-through channel and of the gas flow rate through the annular passage of the chamber is between 90 and 25.

**[0059]** A narrow directed fine-dispersed gas-drop jet is finally formed, when cocurrent gas flows and a preliminarily dispersed gas-drop jet are simultaneously accelerated in the nozzle of the chamber 12 composed of a converging tube 14 and a diffuser 15. While the gas-drop jet flows through the nozzle of the chamber 12, large liquid drops are split due to the action of the peripheral gas flow and additionally accelerated by said gas flow. At the initial liquid velocity of 45 m/s and at the initial gas velocity in the chamber 12 of up to 80 m/s, the average velocity of drops in the generated gas-drop jet was  $\sim 30$  m/s at a distance of 3.5 m from the outlet section of the chamber nozzle. The generated gas-drop jet had sufficiently homogeneous distribution of drop sizes over the jet flow section: drop sizes in the central part of the jet were  $190 \div 200 \mu$ , in the middle annular zone  $175 \div 180 \mu$  and in the peripheral annular zone  $\sim 200 \mu$  and more.

**[0060]** Operation of the sprayer designed according to the second embodiment of the invention (See Figs 6 to 8) is performed in the manner identical to that of the first embodiment of the invention. It differs only in more optimized formation of a gas-drop jet at reduced longitudinal dimension of the sprayer. According to the second embodiment of the invention, the inlet portion 17 of the flow-through channel of said sprayer is made conoid-shaped, with radius of roundness of the side surface being not less than radius of the cylindrical portion 18 of the flow-through channel. Such construction of the inlet portion allows the losses of kinetic energy of the gas-drop jet for the formation of vortex flows in the converging tube to be decreased. The surface of the converging tube is continuously joined to the cylindrical surface of portion 18 to provide for acceleration of the liquid flow and exclude early formation of vortex flows upstream of the diffuser inlet end. Moreover, the continuous reduction in the effective section of the short conoid-shaped inlet portion 17 of the channel causes the cavi-

tation centers to localize in the vicinity of the diffuser inlet section. As a result the fine-dispersed gas-drop jet of homogeneous concentration is generated at minimal losses of energy.

[0061] The results of investigations support the possibility of generating by means of the invention a steady-state fine-dispersed liquid flow at minimal consumption of energy. The flow generated retains the shape and size of its section at the distances of up to 10 m, with improved homogeneity of the drop concentration distribution being provided over the flow section.

#### Industrial applicability

[0062] The claimed invention may be employed in fire-prevention systems, as part of processing equipment, for burning of fuel in heat engineering and transport, as well as for humidifying the environment and spraying disinfectants and insecticides. The invention may be employed as part of fire-fighting means in the stationary and mobile units for suppressing the fires occurred in different kinds of objects: in the rooms of hospitals, libraries and museums, in the ships and planes, as well as for suppressing the sources of fire in the open air, etc.

[0063] The claimed invention is explained through the aforementioned examples of preferred embodiments, however it must be understood by those skilled in the art that in case of industrial implementation of the invention insignificant modifications can be made as compared to the illustrated examples of embodiments without substantial departing from the subject matter of the claimed invention.

#### Claims

1. A liquid sprayer comprising a casing (1) with a flow-through channel composed of sequentially joined and axially aligned an inlet portion (2) formed as a converging tube, a cylindrical portion (3) and an outlet portion (4) formed as a conical diffuser, *is characterized in that* the length of cylindrical portion (3) is not less than its radius but not more than its diameter, thereto the cone angle of the diffuser defining outlet portion (4) of the flow-through channel exceeding the cone angle of the converging tube defining inlet portion (2) of the flow-through channel.
2. A liquid sprayer as claimed in claim 1 *is characterized in that* an apex angle of a cone forming a converging tube is between 6° and 20°, and an apex angle of a cone forming a diffuser is between 8° and 90°.
3. A liquid sprayer as claimed in claim 2 *is characterized in that* an apex angle of a cone forming a converging tube is 13° and an apex angle of a cone

forming a diffuser is 20°.

4. A liquid sprayer as claimed in claim 1 *is characterized in that* inlet edges of the converging tube defining inlet portion (2) of the flow-through channel are made rounded.
5. A liquid sprayer as claimed in claim 1 *is characterized in that* outlet edges of the diffuser defining outlet portion (4) of the flow-through channel are made rounded.
6. A liquid sprayer as claimed in claim 4 or 5 *is characterized in that* the radius of roundness of said edges is 1÷2.5 the radius of cylindrical portion (3) of the flow-through channel.
7. A liquid sprayer as claimed in claim 1 *is characterized in that* it comprises a chamber (7) with a cylindrical channel (8) whose inlet end is connected to a diffuser outlet section, with diameter of cylindrical channel (8) of chamber (7) being at least equal to the diameter of the diffuser outlet section.
8. A liquid sprayer as claimed in claim 7 *is characterized in that* a diameter of cylindrical channel (8) of chamber (7) is 4 ÷ 6 diameters of cylindrical portion (3) of the flow-through channel.
9. A liquid sprayer as claimed in claim 7 *is characterized in that* a length of cylindrical channel (8) of chamber (7) is 10 ÷ 30 diameters of cylindrical portion (3) of the flow-through channel.
10. A liquid sprayer as claimed in claim 7 *is characterized in that* a grid or perforated plate (9) is located at the outlet section of cylindrical channel (8) of chamber (7).
11. A liquid sprayer as claimed in claim 10 *is characterized in that* a total cross-sectional area of holes of perforated plate (9) or grid is 0.4 ÷ 0.7 the cross-sectional area of cylindrical channel (8) of chamber (7).
12. A liquid sprayer as claimed in claim 7 *is characterized in that* at least one tangential opening (11) is formed in the wall of chamber (7) for ejecting gas from the outside into cylindrical channel (8) of chamber (7).
13. A liquid sprayer as claimed in claim 12 *is characterized in that* at least four tangential openings (11) are made in the wall of chamber (7), which are symmetrically arranged by pairs in two cross-sectional planes of cylindrical channel (8) of chamber (7), the first plane extending near the diffuser outlet section and the second plane near the outlet section of



chamber (7).

14. A liquid sprayer as claimed in claim 1 is **characterized in that** it comprises a chamber (12) arranged coaxial to casing (1), on the outside thereof, with at least one passage being formed between an outer surface of casing (1) and an inner surface of the chamber for supplying gas under pressure to the section of outlet portion (4) of the flow-through channel of said sprayer.
15. A liquid sprayer as claimed in claim 14 is **characterized in that** chamber (12) comprises a nozzle composed of sequentially arranged converging tube (14) and diffuser (15), with the nozzle inlet section being communicated with outlet portion (4) of the flow-through channel of said sprayer.
16. A liquid sprayer comprising a casing (16) with a flow-through channel composed of sequentially joined and axially aligned inlet portion (17) formed as a converging tube, a cylindrical portion (18) and an outlet portion (19) formed as a diffuser, is **characterized in that** the length of cylindrical portion (18) is not less than its radius but not more than its diameter, thereto the converging tube forming inlet portion (17) of the flow-through channel is made conoid-shaped, with radius of roundness of the side surface being at least equal to the radius of cylindrical portion (18) of the flow-through channel.
17. A liquid sprayer as claimed in claim 16 is **characterized in that** an apex angle of a cone forming the diffuser is between  $8^\circ$  and  $90^\circ$ .
18. A liquid sprayer as claimed in claim 16 is **characterized in that** the conoid-shaped surface of the converging tube is joined to the surface of cylindrical portion (18) of the flow-through channel at an angle not in the excess of  $2^\circ$ .
19. A liquid sprayer as claimed in claim 16 is **characterized in that** outlet edges of the diffuser forming outlet portion (19) of the flow-through channel are made rounded.
20. A liquid sprayer as claimed in claim 19 is **characterized in that** a radius of roundness of diffuser outlet edges is  $1 \div 2$  radius of cylindrical portion (18) of the flow-through channel.
21. A liquid sprayer as claimed in claim 16 is **characterized in that** it comprises a chamber (22) having a cylindrical channel (23), whose inlet is connected to the diffuser outlet section, with diameter of cylindrical channel (23) of chamber (22) being at least equal to the diameter of the diffuser outlet section.

22. A liquid sprayer as claimed in claim 21 is **characterized in that** a diameter of cylindrical channel (23) of chamber (22) is  $4 \div 6$  diameters of cylindrical portion (18) of the flow-through channel.
23. A liquid sprayer as claimed in claim 21 is **characterized in that** a length of cylindrical channel (23) of chamber (22) is  $10 \div 30$  diameters of cylindrical portion (18) of the flow-through channel.
24. A liquid sprayer as claimed in claim 21 is **characterized in that** a grid or perforated plate (24) is located in the outlet section of cylindrical channel (23) of chamber (22).
25. A liquid sprayer as claimed in claim 24 is **characterized in that** a total cross-sectional area of perforated plate (24) or grid is  $0.4 \div 0.7$  the cross-sectional area of cylindrical channel (23) of chamber (22).
26. A liquid sprayer as claimed in claim 16 is **characterized in that** at least one tangential opening (26) is formed in the chamber wall for ejecting gas from the outside into cylindrical channel (23) of chamber (22).
27. A liquid sprayer as claimed in claim 26 is **characterized in that** at least four tangential openings (26) are symmetrically arranged in the wall of chamber (22) by pairs in two cross-sectional planes of cylindrical channel (23) of chamber (22), wherein the first plane is extending near the diffuser outlet section and the second plane is extending near the outlet section of chamber (22).
28. A liquid sprayer as claimed in claim 16 is **characterized in that** it comprises a chamber (27) arranged coaxial with casing (16), on the outside thereof, wherein at least one passage is formed between the outer surface of casing (16) and the inner surface of chamber (27) for supplying gas under pressure to the section of outlet portion (19) of the flow-through channel.
29. A liquid sprayer as claimed in claim 28 is **characterized in that** chamber (27) comprises a nozzle formed by sequentially arranged converging tube (29) and diffuser (30), wherein the nozzle inlet section is communicated with outlet portion (19) of the flow-through channel.

#### Patentansprüche

1. Flüssigkeitszerstäuber mit einem Gehäuse (1), das einen Durchstromkanal aufweist, der aus einem als konvergierendes Rohr ausgebildeten Einlassab-

- schnitt (2), einem zylindrischen Abschnitt (3) und einem als konischer Diffusor ausgebildeten Auslassabschnitt (4) besteht, die nacheinander miteinander verbunden und axial fluchtend ausgerichtet sind, **dadurch gekennzeichnet, dass** die Länge des zylindrischen Abschnitts (3) nicht kleiner als sein Radius, jedoch nicht größer als sein Durchmesser ist, wobei der Konuswinkel des den Auslassabschnitt (4) des Durchstromkanals bildenden Diffusors größer ist als der Konuswinkel des den Einlassabschnitt (2) des Durchstromkanals bildenden konvergierenden Rohrs.
2. Flüssigkeitszerstäuber nach Anspruch 1, **dadurch gekennzeichnet, dass** der Scheitelwinkel des das konvergierende Rohr bildenden Konus zwischen  $6^\circ$  und  $20^\circ$  liegt und dass der Scheitelwinkel des den Diffusor bildenden Konus zwischen  $8^\circ$  und  $90^\circ$  liegt.
  3. Flüssigkeitszerstäuber nach Anspruch 2, **dadurch gekennzeichnet, dass** der Scheitelwinkel des das konvergierende Rohr bildenden Konus  $13^\circ$  und der Scheitelwinkel des den Diffusor bildenden Konus  $20^\circ$  beträgt.
  4. Flüssigkeitszerstäuber nach Anspruch 1, **dadurch gekennzeichnet, dass** die Einlassränder des den Einlassabschnitt (2) des Durchstromkanals bildenden konvergierenden Rohrs abgerundet sind.
  5. Flüssigkeitszerstäuber nach Anspruch 1, **dadurch gekennzeichnet, dass** die Auslassränder des den Auslassabschnitt (4) des Durchstromkanals bildenden Diffusors abgerundet sind.
  6. Flüssigkeitszerstäuber nach Anspruch 4 oder 5, **dadurch gekennzeichnet, dass** der Abrundungsradius der Ränder das 1 bis 2,5-fache des Radius des zylindrischen Abschnitts (3) des Durchstromkanals beträgt.
  7. Flüssigkeitszerstäuber nach Anspruch 1, **dadurch gekennzeichnet, dass** er eine Kammer (7) mit einem zylindrischen Kanal (8) aufweist, dessen Einlassende mit einem Diffusorauslassabschnitt verbunden ist, wobei der Durchmesser des zylindrischen Kanals (8) der Kammer (7) wenigstens gleich dem Durchmesser des Diffusorauslassabschnitts ist.
  8. Flüssigkeitszerstäuber nach Anspruch 7, **dadurch gekennzeichnet, dass** der Durchmesser des zylindrischen Kanals (8) der Kammer (7) 4 bis 6 Durchmesser des zylindrischen Abschnitts (3) des Durchstromkanals beträgt.
  9. Flüssigkeitszerstäuber nach Anspruch 7, **dadurch gekennzeichnet, dass** die Länge des zylindrischen Kanals (8) der Kammer (7) 10 bis 30 Durchmesser des zylindrischen Abschnitts (3) des Durchstromkanals beträgt.
  10. Flüssigkeitszerstäuber nach Anspruch 7, **dadurch gekennzeichnet, dass** am Auslassabschnitt des zylindrischen Kanals (8) der Kammer (7) ein Gitter oder eine Lochplatte (9) angeordnet ist.
  11. Flüssigkeitszerstäuber nach Anspruch 10, **dadurch gekennzeichnet, dass** die Gesamtquerschnittsfläche der Löcher der Lochplatte (9) oder des Gitters das 0,4 bis 0,7-fache der Querschnittsfläche des zylindrischen Kanals (8) der Kammer (7) beträgt.
  12. Flüssigkeitszerstäuber nach Anspruch 7, **dadurch gekennzeichnet, dass** in der Wand der Kammer (7) wenigstens eine tangentielle Öffnung (11) zum Ausblasen von Gas von der Außenseite in den zylindrischen Kanal (8) der Kammer (7) ausgebildet ist.
  13. Flüssigkeitszerstäuber nach Anspruch 12, **dadurch gekennzeichnet, dass** wenigstens vier tangentielle Öffnungen (11) in der Wand der Kammer (7) ausgebildet sind, die symmetrisch paarweise in zwei Querschnittsebenen des zylindrischen Kanals (8) der Kammer (7) angeordnet sind, wobei sich die erste Ebene in der Nähe des Diffusorauslassabschnitts und die zweite Ebene in der Nähe des Auslassabschnitts der Kammer (7) erstreckt.
  14. Flüssigkeitszerstäuber nach Anspruch 1, **dadurch gekennzeichnet, dass** er eine Kammer (12) aufweist, die koaxial zum Gehäuse (1) an dessen Außenseite angeordnet ist, wobei wenigstens zwischen einer Außenfläche des Gehäuses (1) und einer Innenfläche der Kammer ein Durchgang zum Zuführen von Druckgas zu dem Teil des Austassabschnitts (4) des Durchstromkanals des Zerstäubers ausgebildet ist.
  15. Flüssigkeitszerstäuber nach Anspruch 14, **dadurch gekennzeichnet, dass** die Kammer (12) eine Düse aufweist, die von einem konvergierenden Rohr (14) und einem Diffusor (15) gebildet wird, die nacheinander angeordnet sind, wobei der Düsen-einlassabschnitt mit dem Auslassabschnitt (4) des Durchstromkanals des Zerstäubers in Verbindung steht.
  16. Flüssigkeitszerstäuber mit einem Gehäuse (16), das einen Durchstromkanal aufweist, der aus einem als konvergierendes Rohr ausgebildeten Einlassabschnitt (17), einem zylindrischen Abschnitt (18) und einem als Diffusor ausgebildeten Auslassabschnitt (19) besteht, die nacheinander miteinander

- der verbunden und axial fluchtend ausgerichtet sind, **dadurch gekennzeichnet, dass** die Länge des zylindrischen Abschnitts (18) nicht kleiner als sein Radius, jedoch nicht größer als sein Durchmesser ist, wobei das den Einlassabschnitt (17) des Durchstromkanals bildende konvergierende Rohr kegelförmig ausgebildet ist und der Abrundungsradius der Seitenfläche wenigstens gleich dem Radius des zylindrischen Abschnitts (18) des Durchstromkanals ist.
17. Flüssigkeitszerstäuber nach Anspruch 16, **dadurch gekennzeichnet, dass** der Scheitelwinkel des den Diffusor bildenden Konus zwischen 8° und 90° liegt.
18. Flüssigkeitszerstäuber nach Anspruch 16, **dadurch gekennzeichnet, dass** die kegelförmige Fläche des konvergierenden Rohres mit der Fläche des zylindrischen Abschnitts (18) des Durchstromkanals unter einem Winkel von nicht größer als 2° verbunden ist.
19. Flüssigkeitszerstäuber nach Anspruch 16, **dadurch gekennzeichnet, dass** die Auslassränder des den Auslassabschnitt (19) des Durchstromkanals bildenden Diffusors abgerundet sind.
20. Flüssigkeitszerstäuber nach Anspruch 19, **dadurch gekennzeichnet, dass** der Abrundungsradius der Diffusorauslassränder das 1 bis 2-fache des Radius des zylindrischen Abschnitts (18) des Durchstromkanals beträgt.
21. Flüssigkeitszerstäuber nach Anspruch 16, **dadurch gekennzeichnet, dass** er eine Kammer (22) mit einem zylindrischen Kanal (23) aufweist, dessen Einlass mit dem Diffusorauslassabschnitt verbunden ist, wobei der Durchmesser des zylindrischen Kanals (23) der Kammer (22) wenigstens gleich dem Durchmesser des Diffusorauslassabschnitts ist.
22. Flüssigkeitszerstäuber nach Anspruch 21, **dadurch gekennzeichnet, dass** der Durchmesser des zylindrischen Kanals (23) der Kammer (22) 4 bis 6 Durchmesser des zylindrischen Abschnitts (18) des Durchstromkanals beträgt.
23. Flüssigkeitszerstäuber nach Anspruch 21, **dadurch gekennzeichnet, dass** die Länge des zylindrischen Kanals (23) der Kammer (22) 10 bis 30 Durchmesser des zylindrischen Abschnitts (18) des Durchstromkanals beträgt.
24. Flüssigkeitszerstäuber nach Anspruch 21, **dadurch gekennzeichnet, dass** im Auslassabschnitt des zylindrischen Kanals (23) der Kammer (22) ein Gitter oder eine Lochplatte (24) angeordnet ist.
25. Flüssigkeitszerstäuber nach Anspruch 24, **dadurch gekennzeichnet, dass** die Querschnittsfläche der Lochplatte (24) oder des Gitters das 0,4 bis 0,7-fache der Querschnittsfläche des zylindrischen Kanals (23) der Kammer (22) beträgt.
26. Flüssigkeitszerstäuber nach Anspruch 16, **dadurch gekennzeichnet, dass** wenigstens eine tangentielle Öffnung (26) in der Kammerwand zum Ausblasen von Gas von der Außenseite in den zylindrischen Kanal (23) der Kammer (22) ausgebildet ist.
27. Flüssigkeitszerstäuber nach Anspruch 26, **dadurch gekennzeichnet, dass** wenigstens vier tangentielle Öffnungen (26) symmetrisch in der Wand der Kammer (22) paarweise in zwei Querschnittsebenen des zylindrischen Kanals (23) der Kammer (22) angeordnet sind, wobei die erste Ebene sich in der Nähe des Diffusorauslassabschnitts und die zweite Ebene sich in der Nähe des Auslassabschnitts der Kammer (22) erstreckt.
28. Flüssigkeitszerstäuber nach Anspruch 16, **dadurch gekennzeichnet, dass** er eine Kammer (27) aufweist, die koaxial zum Gehäuse (16) auf dessen Außenseite angeordnet ist, wobei wenigstens ein Durchgang zwischen der Außenfläche des Gehäuses (16) und der Innenfläche der Kammer (27) zum Zuführen von Druckgas zu dem Teil des Auslassabschnitts (19) des Durchstromkanals ausgebildet ist.
29. Flüssigkeitszerstäuber nach Anspruch 28, **dadurch gekennzeichnet, dass** die Kammer (27) eine Düse aufweist, die von dem konvergierenden Rohr (29) und dem Diffusor (30) gebildet wird, die nacheinander angeordnet sind, wobei der Düsen-einlassabschnitt mit dem Auslassabschnitt (19) des Durchstromkanals in Verbindung steht.

#### Revendications

1. Pulvérisateur de liquide comprenant un boîtier (1) doté d'un canal de transfert composé d'une portion d'entrée (2) formée comme un tube convergent, d'une portion cylindrique (3) et d'une portion de sortie formée comme un diffuseur conique, jointes séquentiellement et alignées axialement, **caractérisé en ce que** la longueur de la portion cylindrique (3) n'est pas inférieure à son rayon mais n'est pas supérieure à son diamètre, l'angle de conicité du diffuseur, définissant la portion de sortie (4) du canal de transfert, dépassant l'angle de conicité du tube convergent, définissant la portion d'entrée (2) du

- canal de transfert.
2. Pulvérisateur de liquide selon la revendication 1, **caractérisé en ce qu'un** angle au sommet d'un cône formant un tube convergent est compris entre  $6^\circ$  et  $20^\circ$ , et un angle au sommet d'un cône formant un diffuseur est compris entre  $8^\circ$  et  $90^\circ$ . 5
  3. Pulvérisateur de liquide selon la revendication 2, **caractérisé en ce qu'un** angle au sommet d'un cône formant un tube convergent est de  $13^\circ$ , et un angle au sommet d'un cône formant le diffuseur est de  $20^\circ$ . 10
  4. Pulvérisateur de liquide selon la revendication 1, **caractérisé en ce que** des bords d'entrée du tube convergent définissant la partie d'entrée (2) du canal de transfert sont réalisés de manière arrondie. 15
  5. Pulvérisateur de liquide selon la revendication 1, **caractérisé en ce que** les bords de sortie du diffuseur définissant la partie de sortie (4) du canal de transfert sont réalisés de manière arrondie. 20
  6. Pulvérisateur de liquide selon la revendication 4 ou 5, **caractérisé en ce que** le rayon d'arrondi desdits bords est égal à  $1 \div 2,5$  fois le rayon de la portion cylindrique (3) du canal de transfert. 25
  7. Pulvérisateur de liquide selon la revendication 1, **caractérisé en ce qu'il** comprend une chambre (7) comportant un canal cylindrique (8) dont l'extrémité d'entrée est raccordée à une section de sortie de diffuseur, le diamètre du canal cylindrique (8) de la chambre (7) étant au moins égal au diamètre de la section de sortie de diffuseur. 30 35
  8. Pulvérisateur de liquide selon la revendication 7, **caractérisé en ce qu'un** diamètre du canal cylindrique (8) de la chambre (7) est égal à  $4 \div 6$  diamètres de la portion cylindrique (3) du canal de transfert. 40
  9. Pulvérisateur de liquide selon la revendication 7, **caractérisé en ce qu'une** longueur du canal cylindrique (8) de la chambre (7) est égale à  $10 \div 30$  diamètres de la portion cylindrique (3) du canal de transfert. 45
  10. Pulvérisateur de liquide selon la revendication 7, **caractérisé en ce qu'une** grille ou une plaque perforée (9) est située au niveau de la section de sortie du canal cylindrique (8) de la chambre (7). 50
  11. Pulvérisateur de liquide selon la revendication 10, **caractérisé en ce qu'une** aire de section transversale totale des trous de la plaque perforée (9) ou de la grille est égale à  $0,4 \div 0,7$  fois l'aire de section transversale du canal cylindrique (8) de la chambre (7). 55
  12. Pulvérisateur de liquide selon la revendication 7, **caractérisé en ce qu'au** moins une ouverture tangentielle (11) est formée dans la paroi de la chambre (7) pour éjecter un gaz depuis l'extérieur dans le canal cylindrique (8) de la chambre (7).
  13. Pulvérisateur de liquide selon la revendication 12, **caractérisé en ce qu'au** moins quatre ouvertures tangentielles (11) sont réalisées dans la paroi de la chambre (7), qui sont disposées symétriquement par paires dans deux plans de section transversale du canal cylindrique (8) de la chambre (7), le premier plan s'étendant près de la section de sortie du diffuseur et le deuxième plan près de la section de sortie de la chambre (7).
  14. Pulvérisateur de liquide selon la revendication 1, **caractérisé en ce qu'il** comprend une chambre (12) disposée coaxiale avec le boîtier (1), sur son côté extérieur, au moins un passage étant formé entre une surface extérieure du boîtier (1) et une surface intérieure de la chambre pour délivrer un gaz sous pression à la section de la portion de sortie (4) du canal de transfert dudit pulvérisateur.
  15. Pulvérisateur de liquide selon la revendication 14, **caractérisé en ce que** la chambre (12) comprend une buse composée d'un tube convergent (14) et d'un diffuseur (15) disposés l'un à la suite de l'autre, la section d'entrée de buse communiquant avec la portion de sortie (4) du canal de transfert dudit pulvérisateur.
  16. Pulvérisateur de liquide comprenant un boîtier (16) doté d'un canal de transfert composé d'une portion d'entrée (17) formée comme un tube convergent, d'une portion cylindrique (18) et d'une portion de sortie (19) formée comme un diffuseur, jointes séquentiellement et alignées axialement, **caractérisé en ce que** la longueur de la portion cylindrique (18) n'est pas inférieure à son rayon mais n'est pas supérieure à son diamètre, le tube convergent formant la portion d'entrée (17) du canal de transfert présentant une forme conoïde, le rayon d'arrondi de la surface latérale étant au moins égal au rayon de la portion cylindrique (18) du canal de transfert.
  17. Pulvérisateur de liquide selon la revendication 16, **caractérisé en ce qu'un** angle au sommet d'un cône formant le diffuseur est compris entre  $8^\circ$  et  $90^\circ$ .
  18. Pulvérisateur de liquide selon la revendication 16, **caractérisé en ce que** la surface de forme conoïde du tube convergent est jointe à la surface de la portion cylindrique (18) du canal de transfert à un angle

ne dépassant pas 2°.

19. Pulvérisateur de liquide selon la revendication 16, **caractérisé en ce que** les bords de sortie du diffuseur formant la portion de sortie (19) du canal de transfert sont réalisés de manière arrondie. 5
20. Pulvérisateur de liquide selon la revendication 19, **caractérisé en ce qu'un** rayon d'arrondi des bords de sortie de diffuseur est égal à  $1 \div 2$  fois le rayon de la portion cylindrique (18) du canal de transfert. 10
21. Pulvérisateur de liquide selon la revendication 16, **caractérisé en ce qu'il** comprend une chambre (22) comportant un canal cylindrique (23), dont l'entrée est raccordée à la section de sortie de diffuseur, le diamètre du canal cylindrique (23) de la chambre (22) étant au moins égal au diamètre de la section de sortie de diffuseur. 15
22. Pulvérisateur de liquide selon la revendication 21, **caractérisé en ce qu'un** diamètre du canal cylindrique (23) de la chambre (22) est égal à  $4 \div 6$  diamètres de la portion cylindrique (18) du canal de transfert. 20
23. Pulvérisateur de liquide selon la revendication 21, **caractérisé en ce qu'une** longueur du canal cylindrique (23) de la chambre (22) est égale à  $10 \div 30$  diamètres de la portion cylindrique (18) du canal de transfert. 25
24. Pulvérisateur de liquide selon la revendication 21, **caractérisé en ce qu'une** grille ou une plaque perforée (24) est située dans la section de sortie du canal cylindrique (23) de la chambre (22). 30
25. Pulvérisateur de liquide selon la revendication 24, **caractérisé en ce qu'une** aire de section transversale totale de la plaque perforée (24) ou de la grille est égale à  $0,4 \div 0,7$  fois l'aire de section transversale du canal cylindrique (23) de la chambre (22). 35
26. Pulvérisateur de liquide selon la revendication 16, **caractérisé en ce qu'au** moins une ouverture tangentielle (26) est formée dans la paroi de la chambre pour éjecter un gaz depuis l'extérieur dans le canal cylindrique (23) de la chambre (22). 40
27. Pulvérisateur de liquide selon la revendication 26, **caractérisé en ce qu'au** moins quatre ouvertures tangentielles (26) sont disposées symétriquement dans la paroi de la chambre (22) par paires dans deux plans de section transversale du canal cylindrique (23) de la chambre (22), le premier plan s'étendant près de la section de sortie de diffuseur et le deuxième plan s'étendant près de la section de sortie de la chambre (22). 45
28. Pulvérisateur de liquide selon la revendication 16, **caractérisé en ce qu'il** comprend une chambre (27) disposée coaxiale avec le boîtier (16) sur son côté extérieur, au moins un passage étant formé entre la surface extérieure du boîtier (16) et la surface intérieure de la chambre (27) pour délivrer un gaz sous pression à la section de la portion de sortie (19) du canal de transfert. 50
29. Pulvérisateur de liquide selon la revendication 28, **caractérisé en ce que** la chambre (27) comprend une buse formée par un tube convergent (29) et un diffuseur (30) disposés l'un à la suite de l'autre, la section d'entrée de buse communiquant avec la portion de sortie (19) du canal de transfert. 55

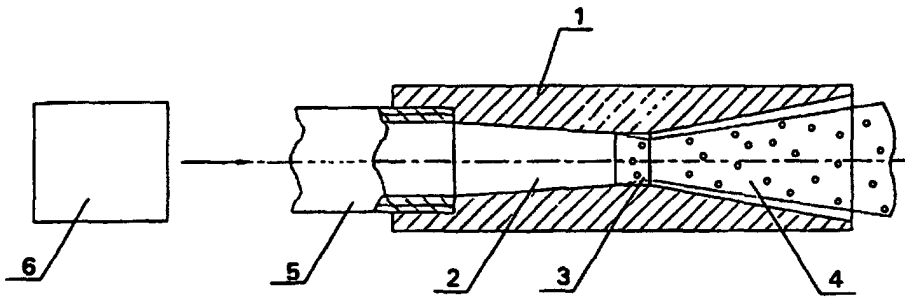

Fig. 1

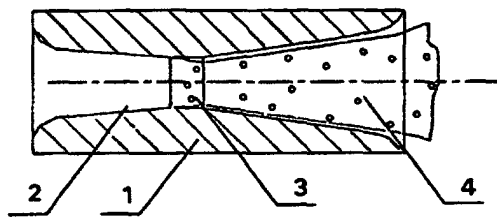

Fig. 2

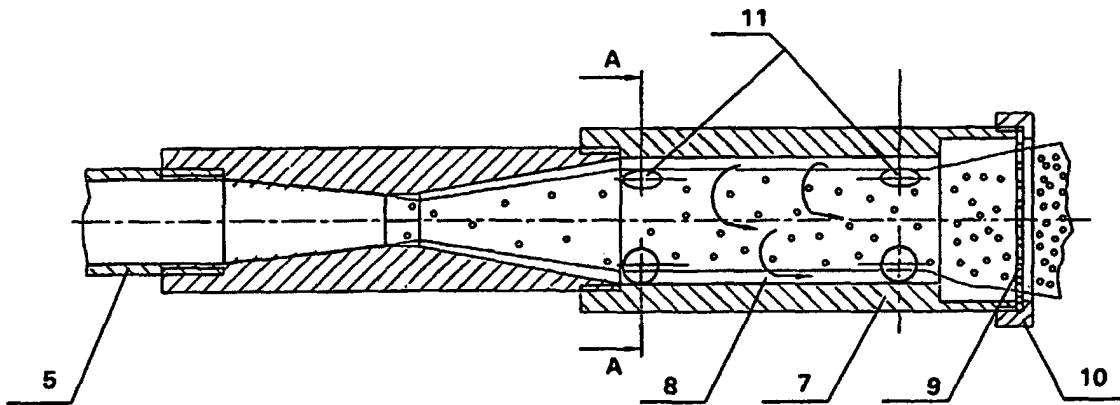

Fig. 3

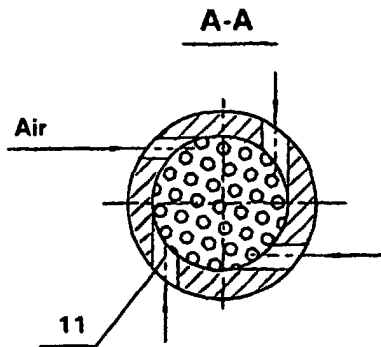

Fig. 4

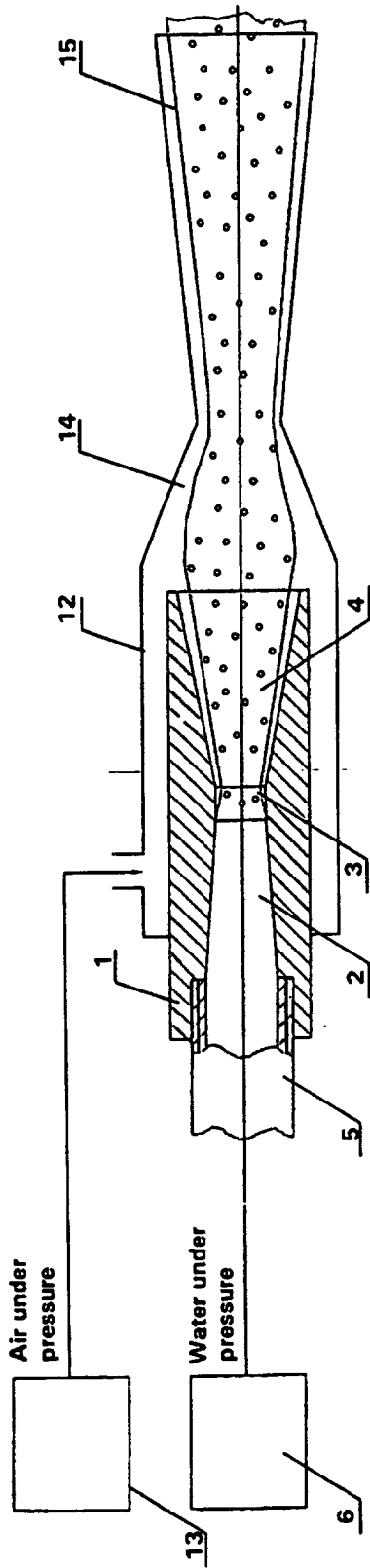

Fig. 5

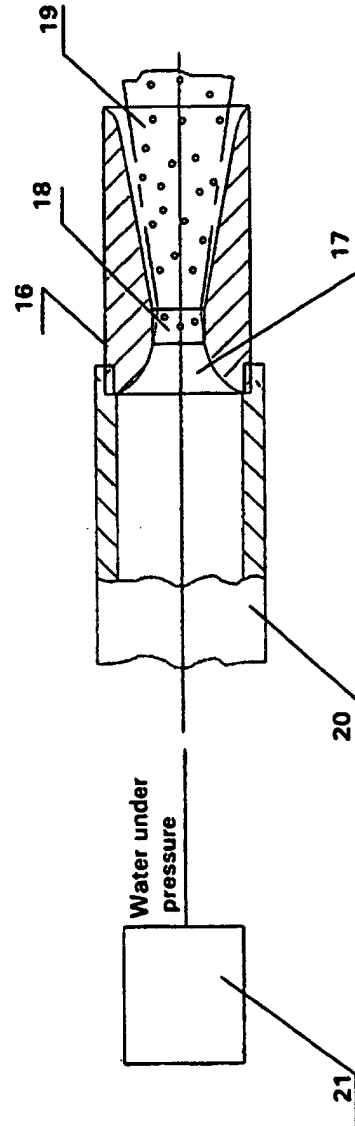

Fig. 6

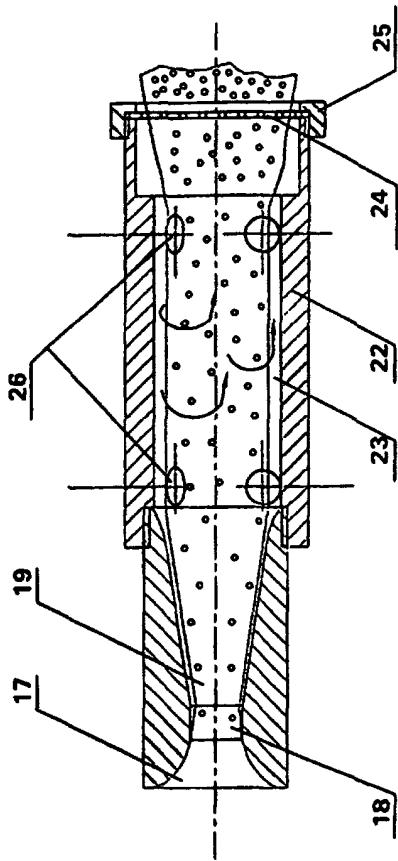

Fig. 7

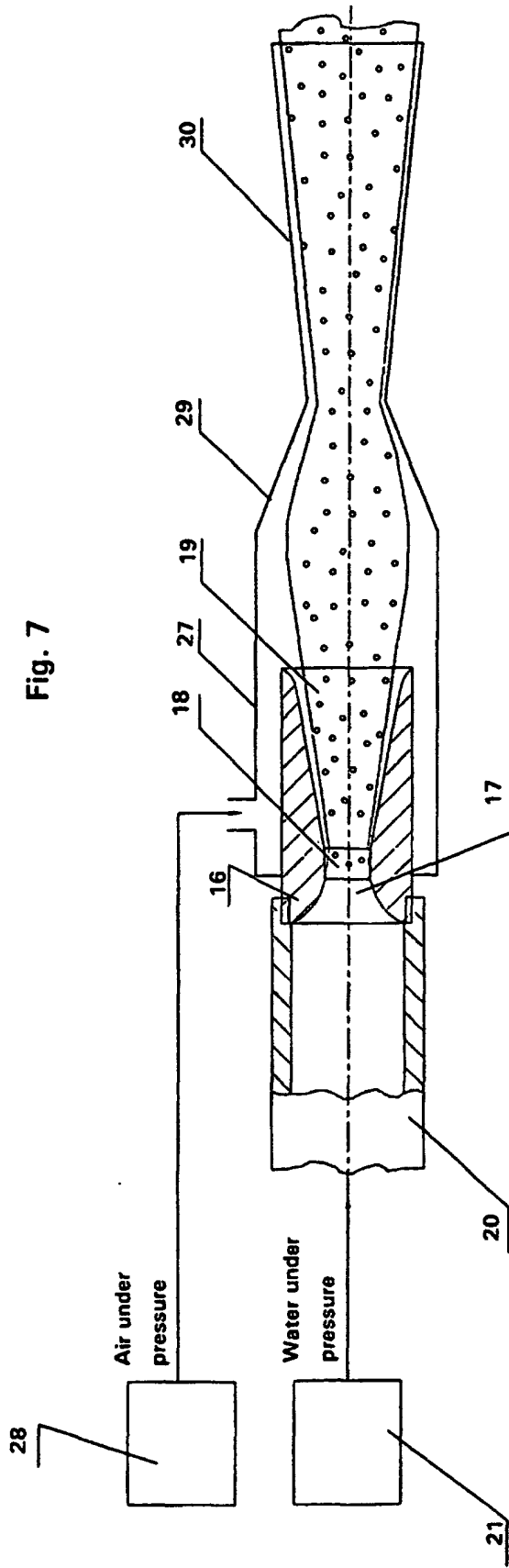

Fig. 8