

(19)



(11)

EP 1 484 217 B1

(12)

EUROPEAN PATENT SPECIFICATION

(45) Date of publication and mention of the grant of the patent:
08.08.2007 Bulletin 2007/32

(51) Int Cl.:
B60Q 1/068^(2006.01) B60Q 1/04^(2006.01)
B60Q 1/26^(2006.01)

(21) Application number: **04013105.4**

(22) Date of filing: **03.06.2004**

(54) Lamp with multi-positional cover

Leuchte mit Mehrstellungsabdeckung

Lampe avec couvercle de protection multipositions

(84) Designated Contracting States:
AT BE BG CH CY CZ DE DK EE ES FI FR GB GR HU IE IT LI LU MC NL PL PT RO SE SI SK TR

• **Waltrip, Doug A.**
Seymour, IN 47274 (US)

(30) Priority: **04.06.2003 US 454557**

(74) Representative: **Lemke, Jörg-Michael**
Jung HML
Patentanwälte
Hofmarkstrasse 10 - Arnhofen
86447 Aindling (DE)

(43) Date of publication of application:
08.12.2004 Bulletin 2004/50

(73) Proprietor: **Valeo Sylvania L.L.C.**
Seymour,
IN 47274 (US)

(56) References cited:
DE-C1- 3 238 104 US-A- 4 707 768
US-A- 4 907 134 US-A- 5 398 173

(72) Inventors:
• **Spencer, Chad E.**
Seymour, IN 47274 (US)

EP 1 484 217 B1

Note: Within nine months from the publication of the mention of the grant of the European patent, any person may give notice to the European Patent Office of opposition to the European patent granted. Notice of opposition shall be filed in a written reasoned statement. It shall not be deemed to have been filed until the opposition fee has been paid. (Art. 99(1) European Patent Convention).

Description**TECHNICAL FIELD**

[0001] This invention relates to lamp assemblies and more particularly to supplementary lamp assemblies, such, for example, as fog lamps, for automotive vehicles.

BACKGROUND ART

[0002] Supplementary lamp assemblies such as the afore-mentioned fog lamps are often provided for automotive vehicles. The lamp assemblies vary in size, shape and location depending upon the vehicle. For example, sedans and trucks usually have these lamp assemblies in very different locations, making mounting of these lamp assemblies a very customized effort. Prior art lamp assemblies have had an adjusting tab (or lamp mounting unit) formed on the lamp assembly housing, requiring its location to be pre-determined so as to cooperate with a mounting bracket on the vehicle. U.S. Patent No. 4,907,134 discusses providing an adjusting or mounting tab on a lens cover; however, for a rectangular lamp assembly, thereby requiring a customized assembly for each different vehicle.

[0003] It would be an advance in the art to provide a lamp assembly that was readily adaptable to more than one vehicle.

DISCLOSURE OF INVENTION

[0004] It is, therefore, an object of the invention to obviate the disadvantages of the prior art.

[0005] It is another object of the invention to enhance vehicle lamp assemblies.

[0006] It is yet another object of the invention provide a vehicle lamp assembly that reduces cost.

[0007] These objects are accomplished, in one aspect of the invention by the provision of a vehicle lamp assembly that comprises a mounting bracket having a first end formed for affixation to a vehicle and a second end formed for affixation to the lamp. A housing for the lamp includes a central axis and a light source mounted with respect to the axis. The housing has a forward portion. A lens cover is provided for the lamp and has an external, circumferential rim formed to engage the forward portion of the housing and an adjusting tab extending from the rim formed to cooperate with the second end of the mounting bracket. The lens cover is freely rotatable about the central axis before being fixed to the forward portion of the housing.

[0008] By providing the adjusting tab on the rim of a freely rotatable lens cover, the lens cover is rotatable about the centerline to new and different locations, thus providing flexibility.

BRIEF DESCRIPTION OF THE DRAWINGS**[0009]**

Fig. 1 is an elevational view of a lens cover in accordance with an embodiment of the invention; and

Fig. 2 is an elevational, sectional view taken along the line 2-2 of Fig. 1.

BEST MODE FOR CARRYING OUT THE INVENTION

[0010] For a better understanding of the present invention, together with other and further objects, advantages and capabilities thereof, reference is made to the following disclosure and appended claims in conjunction with the above-described drawings.

[0011] Referring now to the drawings with greater particularity, there is shown in Fig. 1a lens cover 26 for a vehicle lamp assembly 10. The lens cover 26 is circular, optic-free, and has a circumferential rim 28 with an adjusting tab 30 projecting away from the rim 28. The lens cover 26 is freely rotatable about a central axis 20.

[0012] Referring now to Fig. 2, which is sectional view taken along the line 2-2 of Fig. 1, there is shown a vehicle lamp assembly 10 comprising a mounting bracket 12 with a first end 14 formed for affixation to a vehicle and a second end 16 formed for affixation to the vehicle lamp assembly. The second end 16 is preferably formed as a threaded portion 17.

[0013] A housing 18 for the lamp assembly 10 includes a central axis 20 with a light source 22, for example, a halogen bulb, mounted with respect to the axis 20, in this instance, the light source is coaxial with the central axis.

An interior wall 32 of the housing 18 can be provided with a reflective region having an optical prescription thereon,

[0014] The housing 18 has a forward portion 24 for receiving the lens cover 26. In a preferred embodiment of the invention the circumferential rim 28 of the lens cover 26 is provided with a groove 36 for engaging the forward portion 24 of the housing 18 and the adjusting tab 30 is provided with an aperture 37 (see Fig. 1) for receiving an adjusting screw 34.

[0015] For mounting in a vehicle, the location of the mounting bracket 12 is determined and the alignment desired for the housing 18 is also ascertained. With these positions fixed, the lens cover 26 is aligned with the forward portion of the housing 18 so the adjusting tab 30 is aligned with the second end 16 of the mounting bracket 12. The lens cover 26 is affixed to the housing 18 appropriately, as by cementing, and the lamp assembly 10 is then affixed to the mounting bracket 12 by means of an adjusting screw 34.

[0016] Because the lens cover 26 is preferably optic-free and freely rotatable, (some lens optic treatment may be applicable) it will be apparent that it can be moved about the central axis 20 to any desired location to align with the mounting bracket. In Fig. 1 several alternate po-

sitions of the adjusting tab 30 are shown in phantom..

[0017] There is thus provided a vehicle lamp assembly that is virtually universal. The vehicle manufacturer has freedom to design the vehicle and position the mounting bracket where it is convenient and still know that the lamp assembly can be properly aligned to provide the desired lighting pattern.

[0018] While there have been shown and described what are at present considered to be the preferred embodiments of the invention, it will be apparent to those skilled in the art that various changes and modification can be made herein without departing from the scope of the invention as defined by the appended claims.

Claims

1. A vehicle lamp assembly (10) comprising:

a mounting bracket (12) having a first end (14) formed for affixation to a vehicle and a second end (16) formed for affixation to said lamp assembly (10);

a housing (18) for said lamp assembly (10) including a central axis (20) and a light source (22) mounted with respect to said central axis (20), said housing (18) having a forward portion (24); **characterized in that**

a lens cover (26) is provided for said lamp assembly (10), said lens cover (26) having an external, circumferential rim (28) formed to engage said forward portion (24) of said housing (18) and an adjusting tab (30) extending from said rim (28) and formed to cooperate with said second end (16) of said mounting bracket (12), said lens cover (26) being freely rotatable about said central axis (20) before being fixed to the forward portion of the housing.

2. The vehicle lamp assembly (10) of Claim 1 wherein said lens cover (26) is circular.

3. The vehicle lamp assembly (10) of Claim 1 wherein said lens cover (26) is optic-free.

4. The vehicle lamp assembly (10) of Claim 1 wherein said housing (18) has an interior wall (32) defining a reflective region having an optical prescription.

5. The vehicle lamp assembly (10) of Claim 1 wherein said adjusting tab (30) cooperates with said second end (16) of said mounting bracket (12) by means of an adjusting screw (34).

Patentansprüche

1. Fahrzeuglampenbaugruppe (10) mit einer Halte-

klammer (12), die ein zur Befestigung an einem Fahrzeug ausgebildetes erstes Ende (14) und ein zur Befestigung an der Lampenbaugruppe ausgebildetes zweites Ende (16) besitzt;

einem Gehäuse (18) für die Lampenbaugruppe (10) mit einer Mittelachse (20) und einer bezüglich der Mittelachse montierten Lichtquelle (22), wobei das Gehäuse (18) einen vorderen Teil (24) aufweist,

dadurch gekennzeichnet, dass

für die Lampenbaugruppe (10) eine Linsenabdeckung (26) vorgesehen ist, dass die Linsenabdeckung (26) einen äußeren umlaufenden Rand (28), der derart geformt ist, dass er am vorderen Teil (24) des Gehäuses (18) angreift, und eine Einstelllasche (30) besitzt, die sich von dem Rand (28) wegstreckt und derart ausgebildet ist, dass sie mit dem zweiten Ende (16) der Halteklammer (12) zusammenarbeitet, und dass die Linsenabdeckung (26) um die Mittelachse (20) frei drehbar ist, bevor sie an dem vorderen Teil des Gehäuses befestigt wird.

2. Fahrzeuglampenbaugruppe (10) nach Anspruch 1, bei welcher die Linsenabdeckung (26) kreisförmig ist.

3. Fahrzeuglampenbaugruppe (10) nach Anspruch 1, bei welcher die Linsenabdeckung (26) keine Optik aufweist.

4. Fahrzeuglampenbaugruppe (10) nach Anspruch 1, bei welcher das Gehäuse (18) eine innere Wand (32) besitzt, die einen reflektierenden Bereich mit einer optischen Vorschrift definiert.

5. Fahrzeuglampenbaugruppe (10) nach Anspruch 1, bei welcher die Einstelllasche (30) mittels einer Einstellschraube (34) mit dem zweiten Ende (16) der Halteklammer (12) zusammenarbeitet.

Revendications

1. Ensemble (10) à lampe de véhicule comprenant :

une console (12) de montage ayant une première extrémité (14) conformée pour se fixer à un véhicule et une deuxième extrémité (16) conformée pour se fixer à l'ensemble (10) à lampe ; une enveloppe (18) pour l'ensemble (10) à lampe comprenant un axe (20) central et une source (22) lumineuse montée par rapport à l'axe (20) central, l'enveloppe (18) ayant une partie (24) avant ; **caractérisé en ce que**

il est prévu un couvercle (26) de lentille pour l'ensemble (10) à lampe, le couvercle (26) de lentille ayant un bord (28) circonférenciel extérieur conformé de manière à coopérer avec la partie (24) avant de l'enveloppe (18) et une patte

- (30) d'ajustement, s'étendant à partir du bord (28) et conformée pour coopérer avec la deuxième extrémité (16) de la console (12) de montage, le couvercle (26) de lentille pouvant tourner librement autour de l'axe (20) central avant d'être fixé à la partie avant de l'enveloppe. 5
2. Ensemble (10) à lampe de véhicule suivant la revendication 1, dans lequel le couvercle (26) de lentille est circulaire. 10
3. Ensemble (10) à lampe de véhicule suivant la revendication 1, dans lequel le couvercle (26) de lentille n'a pas d'optique. 15
4. Ensemble (10) à lampe de véhicule suivant la revendication 1, dans lequel l'enveloppe (18) a une paroi (32) intérieure définissant une région de réflexion ayant une prescription optique. 20
5. Ensemble (10) à lampe de véhicule suivant la revendication 1, dans lequel la patte (30) d'ajustement coopère avec la deuxième extrémité (16) de la console (12) de montage au moyen d'une vis (34) d'ajustement. 25

30

35

40

45

50

55

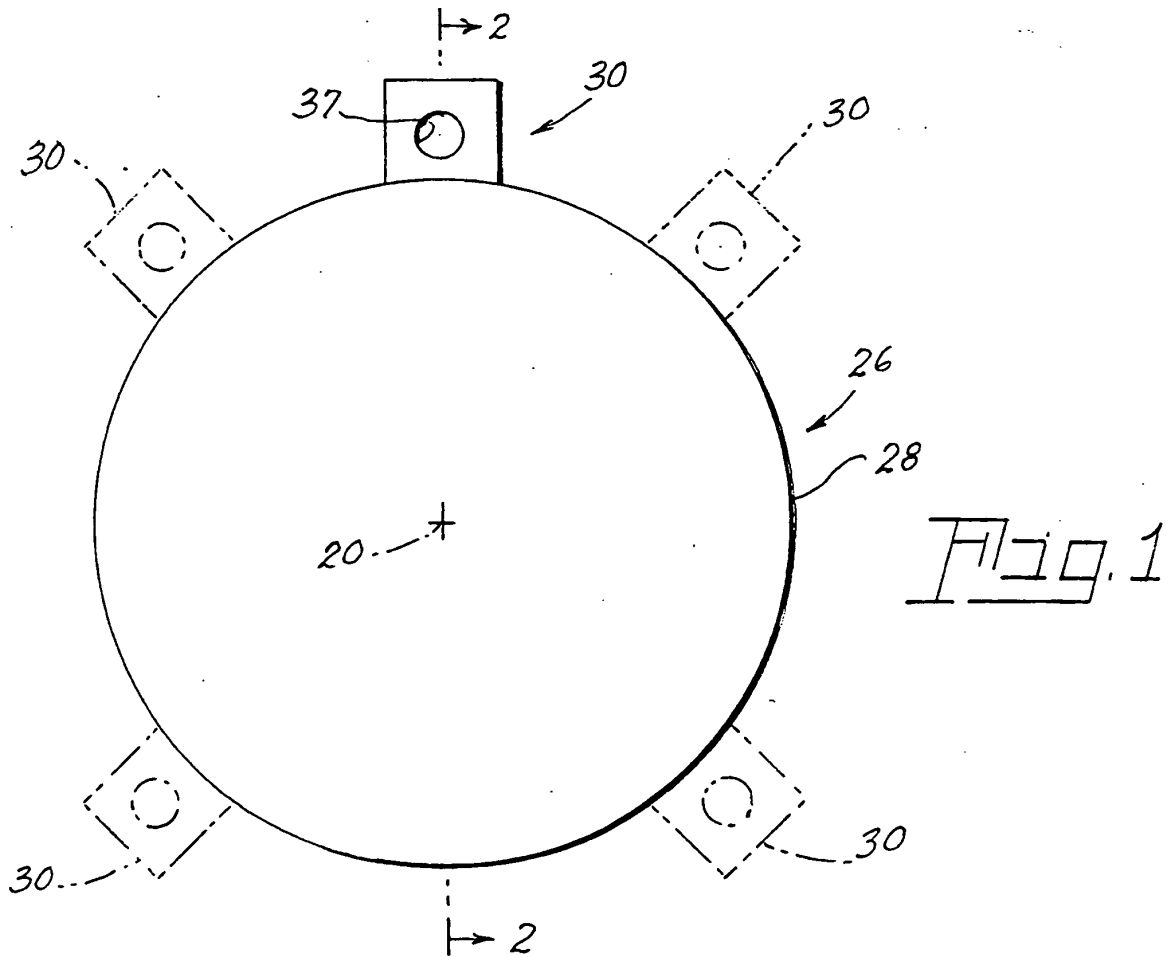
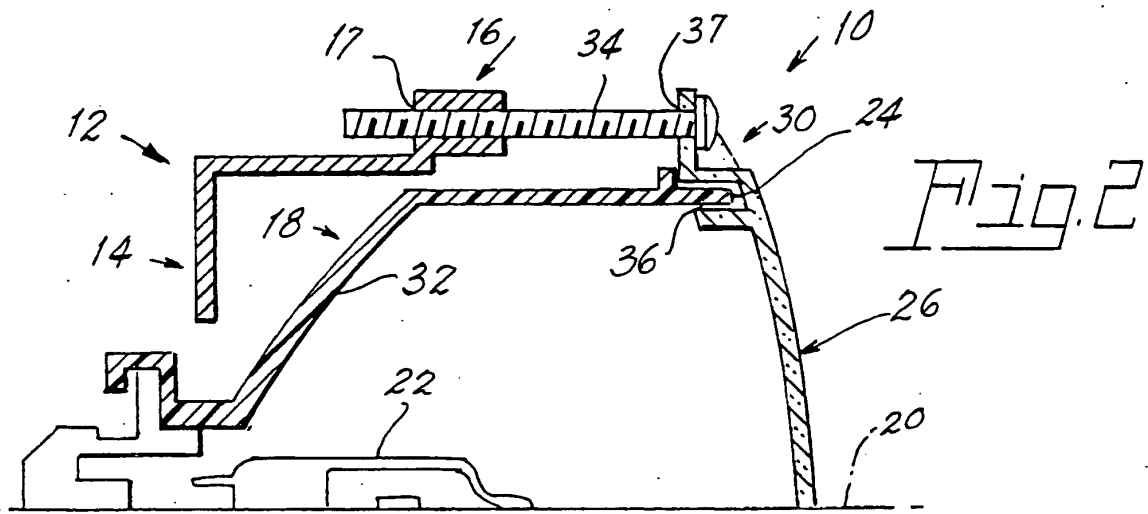

REFERENCES CITED IN THE DESCRIPTION

This list of references cited by the applicant is for the reader's convenience only. It does not form part of the European patent document. Even though great care has been taken in compiling the references, errors or omissions cannot be excluded and the EPO disclaims all liability in this regard.

Patent documents cited in the description

- US 4907134 A [0002]