



US 20170365200A1

(19) **United States**

(12) **Patent Application Publication**
Wagner

(10) **Pub. No.: US 2017/0365200 A1**

(43) **Pub. Date: Dec. 21, 2017**

(54) **SIGNAGE SYSTEM**

G01J 1/42 (2006.01)

(71) Applicant: **Mark Wagner**, Boylston, MA (US)

G09F 13/00 (2006.01)

(72) Inventor: **Mark Wagner**, Boylston, MA (US)

H05B 33/08 (2006.01)

G09F 7/18 (2006.01)

(21) Appl. No.: **15/477,718**

(52) **U.S. Cl.**

(22) Filed: **Apr. 3, 2017**

CPC **G09F 21/04** (2013.01); **H05B 33/08** (2013.01); **G09F 13/22** (2013.01); **G09F 7/18** (2013.01); **G09F 21/048** (2013.01); **G01J 1/42** (2013.01); **G09F 13/005** (2013.01); **G09F 9/33** (2013.01); **G09F 2007/1852** (2013.01); **G09F 2013/222** (2013.01)

Related U.S. Application Data

(63) Continuation of application No. 15/002,212, filed on Jan. 20, 2016, now abandoned, which is a continuation of application No. 14/792,463, filed on Jul. 6, 2015, now abandoned, which is a continuation of application No. 14/529,755, filed on Oct. 31, 2014, now abandoned, which is a continuation of application No. 12/994,045, filed on Mar. 3, 2011, now Pat. No. 8,875,426, filed as application No. PCT/US2009/045102 on May 25, 2009.

(60) Provisional application No. 61/055,920, filed on May 23, 2008.

(57)

ABSTRACT

A signage system (10) including one or more visual display devices (11), each mounted for display behind the windshield (15) of one or more parked and ignition-off vehicles (16). Each sign (11) has a visual display surface (12) that is capable of forming an illuminated graphic display (13) on the visual display surface (12). The visual display surface (12) would be visible to observers in front of the vehicle (16). The system (10) includes wireless communication hardware (60) that allows the visual display (11) to be programmed by a remote programming device (41). Each of the display devices (11) can be programmed to have a separate message and each message would scroll from left to right across the display surface (12) in a time coordinated manner so that the message appears to scroll consistently from left to right across the visual field of the plurality of display surfaces (12).

Publication Classification

(51) **Int. Cl.**

G09F 21/04 (2006.01)

G09F 13/22 (2006.01)

G09F 9/33 (2006.01)

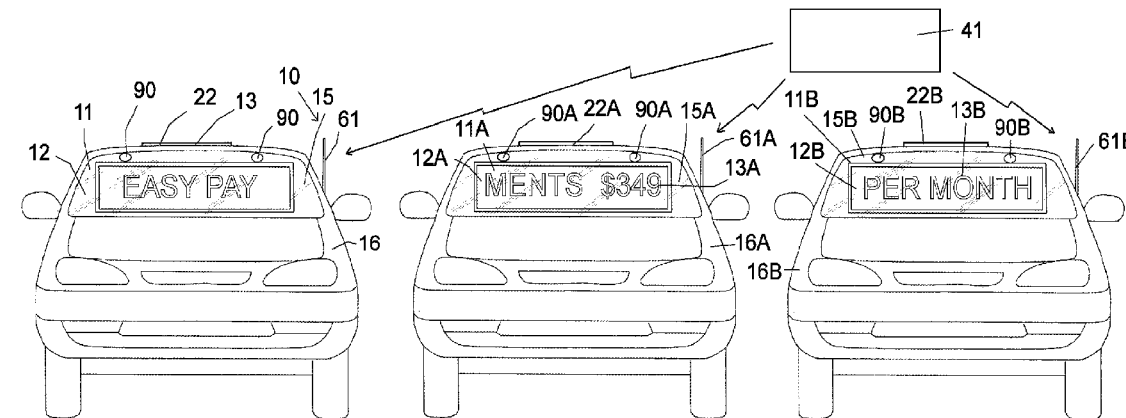

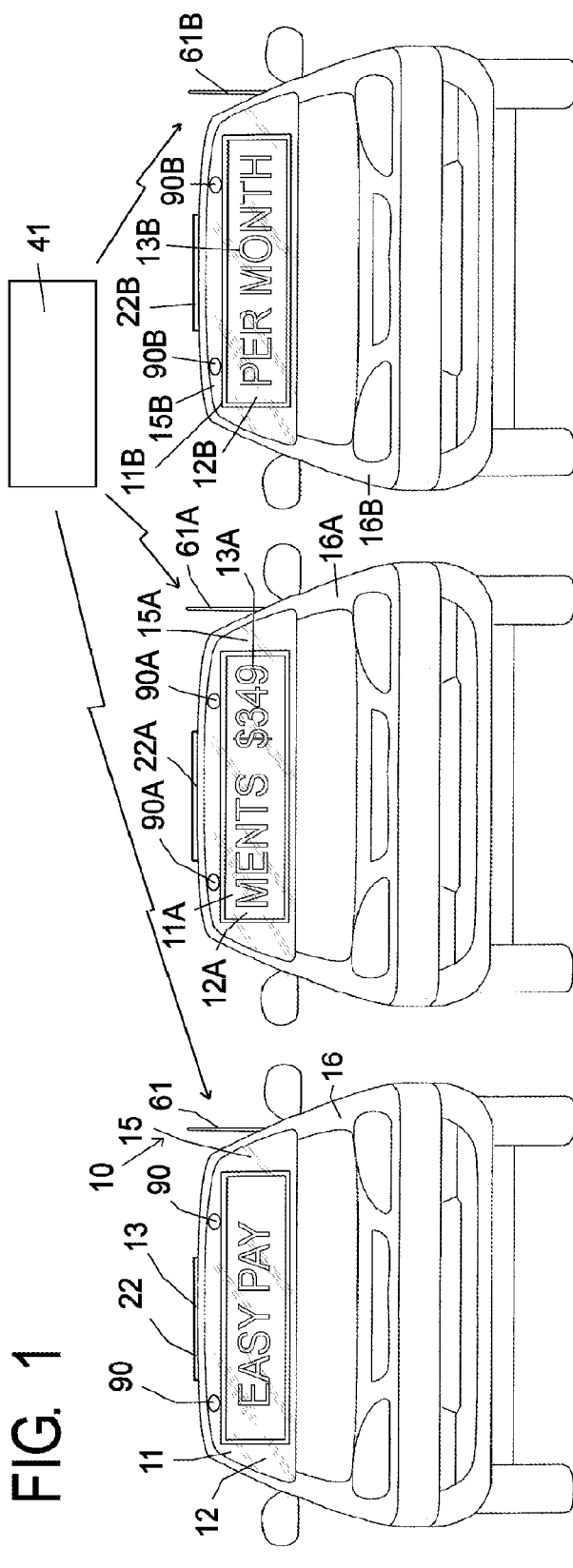

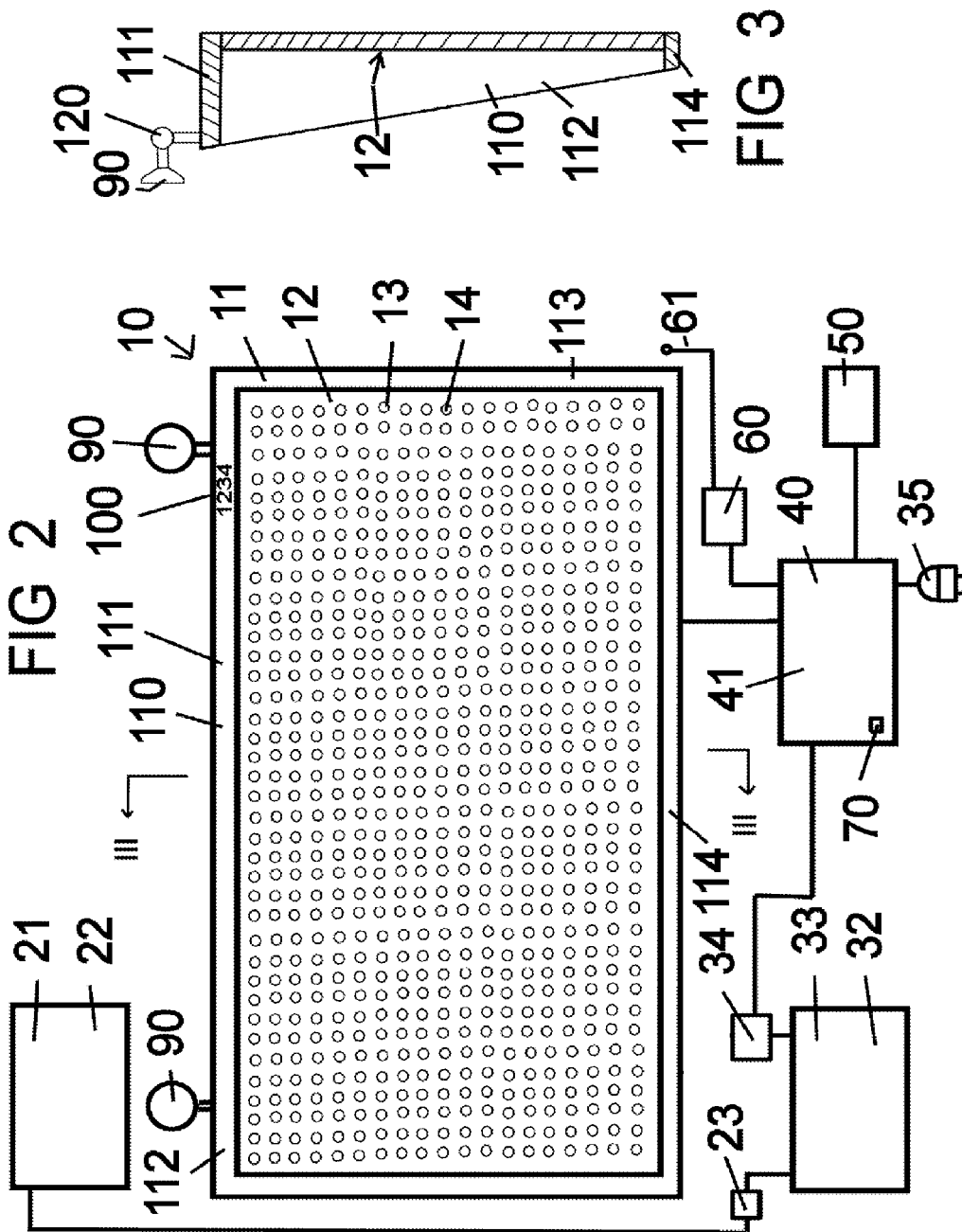

SIGNAGE SYSTEM

TECHNICAL FIELD

[0001] This invention involves a illuminated signage system for outdoor advertising.

BACKGROUND ART

[0002] Outdoor signage systems face a number of challenges. First of all, unless the signage systems are illuminated, they are of limited visibility at night. Eliminating the signage systems requires the provision of electric power which normally involves running long power lines. Furthermore, local regulations often restrict the use of outdoor signage. The installation of signage systems can be very complicated and time-consuming. Furthermore, the adaption of signage system messages so that the message can be appropriate can involve significant complications.

[0003] These and other difficulties experienced with the prior art devices have been obviated in a novel manner by the present invention.

[0004] It is, therefore, an outstanding object of some embodiments of the present invention to provide a signage system that is easy to install.

[0005] It is a further object of some embodiments of the invention to provide a signage system that can be illuminated so that it has high visibility even that night.

[0006] It is a further object of some embodiments of the invention to provide a signage system that can be illuminated using minimum power technology.

[0007] It is a further object of some embodiments of the invention to provide a signage system that can be illuminated by solar power.

[0008] It is a further object of some embodiments of the invention to provide a signage system whose message can be easily modified, including modification from remote sources.

[0009] It is a further object of some embodiments of the invention to provide a signage system that can include several display units each of which can be programmed with a separate message or a coordinated message.

[0010] It is a further object of some embodiments of the invention to provide a signage system that can be located inside of a vehicle so that it is not subject to outside signage restrictions.

[0011] It is a further object of some embodiments of the invention to provide a signage system that can be located inside of a vehicle so that it is not subject to weather conditions to which outside signage is normally exposed.

[0012] With these and other objects in view, as will be apparent to those skilled in the art, the invention resides in the combination of parts set forth in the specification and covered by the claims appended hereto, it being understood that changes in the precise embodiment of the invention herein disclosed may be made within the scope of what is claimed without departing from the spirit of the invention.

BRIEF SUMMARY OF THE INVENTION

[0013] This invention involves several embodiments, and generally involves a signage system (10) including one or more visual display devices (11), each of which is mounted for display behind the windshield (15) of one or more parked and ignition-off vehicles (16). The sign (11) has a visual display surface (12) that is capable of forming an illumi-

nated graphic display (13) on the visual display surface (12). The visual display surface (12) would be placed adjacent the windshield (15) of a vehicle (16) so that the visual display surface (12) would be visible to observers in front of the vehicle (16). The system (10) includes wireless communication hardware (60) that allows the visual display (11) to be programmed by a remote programming device (41). Each of the display devices (11) can be programmed so that each would have a separate message and each message would scroll from left to right across the display surface (12) in a time coordinated manner so that the message appears to scroll consistently from left to right across the visual field of the plurality of display surfaces (12).

BRIEF DESCRIPTION OF THE SEVERAL VIEWS OF THE DRAWING

[0014] The character of the invention, however, may best be understood by reference to one of its structural forms, as illustrated by the accompanying drawings, in which:

[0015] FIG. 1 is a schematic front elevation view of an embodiment of the signage system embodying the principles of the present invention,

[0016] FIG. 2 is a schematic view of some of the elements included in a signage system embodying the principles of the present invention, and

[0017] FIG. 3 is a sectional right elevation view taken along the line III-III of FIG. 2.

DETAILED DESCRIPTION OF THE INVENTION

[0018] This invention is a signage system, including a visual display device that is mounted inside of a vehicle so that the visual display device presents a visual display surface to the front windshield of the vehicle. The signage system is adapted to present a message and particularly a marketing and sales message appropriate for the particular vehicle in which the device is mounted, two members of the public who can see the windshield of vehicle. In the preferred embodiment of this invention, the system is mounted in a plurality of adjacent vehicles, and the message presented by the signage system in each vehicle is coordinated. For example, the message might appear to move from one vehicle to the next in order to create an effective visual effects.

[0019] Description: A signage system for communicating to the public, a marketing and sales message appropriate for the vehicle, by means a display device that presents of a matrix of highly efficient light emitting diodes (LEDs), mounted on a display surface, through the windshield. The device is designed to fit inside of the windshield of a vehicle. The LED components have low energy usage, have maximum angle visibility, and have a long life. In the preferred embodiment of this invention, the display is programmable, so that it has a variable message capability. In the preferred embodiment of this invention, the display device is attached to the inside of the window with a system of suction cups. In the preferred embodiment of this invention, need to display device has a flexible frame structure, and a combination of support ribs and exterior clear plastic, so that the flexible frame and housing allow the device to contour to the inside surface of the windshield. In the preferred embodiment of this invention, the device would be battery powered for portability, and would include a solar panel that would

recharge the battery. The system would include day and night sensor to control the intensity of the display and a timer that controls on and off condition of the device, for example over a daily or weekly cycle. The system would include computer connection capabilities, such as a USB port to allow laptop programming of the display device. The system might also include a highly visible identification number to aid with programming the display, and wireless capable antenna for programming with a local or remote computer or laptop.

[0020] Field of Invention: This invention relates generally to the field of electronic signage and more specifically to a system including a visual display device that is adapted to be mounted in a vehicle and attached to the inside surface of the front windshield of a vehicle, for communicating a marketing and sales message appropriate for the particular vehicle in which it is housed.

[0021] Summary: In accordance with a preferred embodiment of the invention, there is disclosed a system for communicating a marketing and sales message appropriate for a vehicle comprising: a highly efficient LED sign designed to fit in the windshield of a vehicle. The LED components have low energy consumption. The LED components have maximum angle visibility. The system has programmable message capability, so that the message can be changed as desired. In the preferred embodiment, the sign would be attached to the inside of the windshield of a vehicle with a system of suction cups. The sign would have a flexible frame structure, in which a housing is a combination of support ribs and exterior clear plastic. The flexible frame and housing allow the ability to contour with the inside surface of the windshield. The system would preferably be battery powered for portability, and preferably would be powered by a solar rechargeable battery. The system would include a day and night sensor, and timer that could control on and off capabilities of the system. The system would include a computer connection such as a USB port to allow laptop programming. The system would include highly visible identification number to aid with programming. The system would include wireless capable antenna for programming with laptop or other computer.

[0022] In accordance with a preferred embodiment of the invention, there is disclosed a process for communicating a marketing and sales message appropriate for the individual vehicle comprising the steps of: placing a highly efficient LED sign, designed to fit in the windshield of a vehicle, so that the sign presents a visual message through the windshield of the vehicle to observers in front of the vehicle. The sign is attached to the inside of the window with a system of suction cups, and because the sign has a flexible frame structure, and a housing that is a combination of support ribs and exterior clear plastic, the flexible frame and housing allow the sign to conform in shape to the contour with the inside surface of the windshield. The sign includes LED components that have low energy consumption, and have maximum angle visibility. The assignment which has, programmable message capability, is then programmed so that the selected message is presented.

[0023] The sign includes a computer connection such as a USB port to allow local or remote laptop or other computer programming, highly visible identification number to aid with programming, and wireless capable antenna for programming with local or remote laptop or other computer. The sign is then set to display the message, the sign being

battery powered for portability, and having solar rechargeable battery, and a day and night sensor, timer that controls on and off capabilities.

[0024] Qualities & Benefits: Some of the various embodiments of the signage system of the present invention are designed to provide a direct way to market to the potential client.

[0025] They are further designed to provide an accurate product specific message between the vehicle and potential client to provide a wide array of messages that can be created. They are further designed to provide a highly visible message to drive-by traffic. They are further designed to provide a highly visible message to foot traffic. They are further designed to provide a way to have a roadside message. They are further designed to provide a direct way to articulate several messages at the same time. They are further designed to provide a highly concentrated message that is vehicle or marketing program specific to the vehicle. They are further designed to provide a direct way to explain important vehicle specific information to the potential passer-by or foot traffic. They are further designed to provide a direct way to market a message at the best possible drive or foot traffic periods. They are further designed to provide a high level of security by being placed in the vehicle. They are further designed to comply with various zoning ordinances because the sign is inside the vehicle and fully portable. They are further designed to be fully transferable to all vehicles. They are further designed to provide a multi-row sign to allow multiple messages at one time.

[0026] Primary Elements: Some of the various embodiments of this invention may have the following elements. The systems may include a highly efficient LED (or other illumination technology) sign designed to fit in the windshield of a vehicle. The sign would include LED components have low voltage and low energy consumption. The sign would include LED components that have maximum angle visibility. The sign would include programmable message capability. The sign could be attached to the inside of the window with a system of suction cups and could have flexible frame structure housing that is a combination of support ribs and exterior clear plastic flexible frame. The housing could allow the sign to conform to the contour inside surface of the windshield. The system could be battery powered for portability, and employ solar rechargeable battery and solar panel. The system could also include a day and night sensor, and a timer that controls on and off capabilities of the system. The system could include a computer connect connection such as a USB port or wireless connection to allow local or remote laptop or other computer programming of the message displayed by the sign, and could include a highly visible identification number to aid with programming.

[0027] Secondary Elements: The system could include a battery system security disabler that would automatically disable the battery and/or the overall system if the system were stolen. The system could also include unique power and other cord connection technology for security.

[0028] Substitute Elements: the system could be adapted so that it could be used in the rear or side windows, if needed or desired.

[0029] FIG. 1 is an overall representation of one embodiment of a signage system embodying the principles of the present invention. The overall signage system is designated by the numeral 10. The main component of the system 10 is

one or more visual display devices or signs **11**, **11A**, and **11B**, each of which is mounted for display behind the windshield **15**, **15A**, and **15B** of one or more vehicles **16**, **16A**, and **16B**. Each vehicle **16**, **16A**, and **16B**, contains substantially identical equipment and will be discussed as represented by vehicle **16** and its equipment. Each sign **11** has a visual display surface **12** that is capable of forming an illuminated visual message **13** or graphic display **13** on the visual display surface **12**. In the preferred embodiment, the visual display surface **12** would be placed adjacent the windshield **15** of a vehicle **16** so that the visual display surface **12** would be visible to observers in front of the vehicle **16**.

[0030] The system **10** might include a Solar Panel Battery Recharger **21** (see FIG. 2) that includes a solar panel **22** that will be mounted in a position in which it will receive sunlight, for example either on the vehicle's exterior, such as the rooftop, hood, or trunk, or in the interior of the vehicle directed to a sun-exposed window.

[0031] The system **10** might also include wireless communication hardware **60** (see FIG. 2) and a wireless antenna **61** that allows the visual display **11** to communicate wirelessly with a message programming device **41** such as a laptop computer with message programming capability.

[0032] The system **10** might also include suction cups **90** for attachment of the visual display device **11** to the inside surface of the windshield **15** of the vehicle **16**.

[0033] In the preferred embodiment of this invention, the message programming device **41** would be used to program each of the display devices **11** so that each would have a separate message and each message would scroll from left to right across the display surface **12** in a time coordinated manner so that the message appears to scroll consistently from left to right across the visual field of the plurality of display surfaces **12**.

[0034] FIG. 2 is a diagrammatic representation of the conceptual relationship between various detailed elements of one embodiment of the present invention. The overall signage system is designated by the numeral **10**. The main component of the system **10** is a visual display device or sign **11**. The sign **11** has a visual display surface **12** that carries a matrix **13** of illuminatable devices or lamps **14**, that are capable of forming a visual message or graphic display on the visual display surface **12** by selective illumination of the lamps **14**. In the preferred embodiment, the visual display surface **12** would be placed adjacent the windshield **15** (see FIG. 1) of a vehicle **16** (see FIG. 1) so that the visual display surface **12** would be visible to observers in front of the vehicle **16**.

[0035] The system **10** might include a Solar Panel Battery Recharger **21** that includes a solar panel **22** that will be mounted in a position in which it will receive sunlight, for example either on the vehicle's exterior, such as the rooftop, hood, or trunk, or in the interior of the vehicle directed to a sun-exposed window. The recharger **21** would also include suitable control electronics **23** to assure that a battery **32** is charged properly.

[0036] The system **10** might also include a battery **32**, and in particular, a solar powered battery housed in an insulated battery box **33** within the vehicle **16**. The system might also include a utility line inverter **34** that converts the voltage from the battery to a different voltage such as 110 volt AC, for use in powering the visual display **11** and the other components of the system.

[0037] The system **10** might also include a conventional 110 volt AC plug and power cord **35** that can be used to plug into a conventional electric outlet to provide power to the system **10**.

[0038] The system **10** might also include the message controller **40** that includes controllers and drive systems **41** that can be programmed to control the illumination function of the visual display.

[0039] The system **10** might also include a light sensor **50** to monitor daylight and control operation time of the visual display **12**.

[0040] The system **10** might also include wireless communication hardware **60** and wireless antenna **61** that allow the message controller **40** to communicate wirelessly with a message programming device **41** such as a laptop computer with message programming capability.

[0041] The system **10** might also include a computer connection such as a USB port **70** in the message controller **40** for direct computer laptop connectivity and message programming of the message controller **40**.

[0042] The system **10** might also include a matrix **80** of illumination devices **81** such as a low voltage, low energy consumption LED light devices with maximum angle visibility, capable, when selectively illuminated to form a visual message or graphic presentation.

[0043] The system **10** might also include suction cups **90** for attachment of the visual display device to the inside surface of the windshield **15** of the vehicle **16**.

[0044] The system **10** might also include a highly visible identification number **100** that specifically identifies the visual display device and provides for efficient identification and programming of the device.

[0045] The system **10** might also include a forwardly directed shade frame or structure **110**, that includes a top shade **111**, a left side shade **112**, a right side shade **113**, and a bottom shade **114**. It has been found that this shade structure improves the visibility of the message on the display surface **12** by blocking off axis light and thereby reducing glare on the display surface. This shade structure **110** also provides some mechanical protection for the display surface **12** and its elements.

[0046] FIG. 3 shows a sectional right elevation view of the system **10** shown in FIG. 2 as viewed a long line III-III. In FIG. 3, the shade frame **110** can be shown. It can be seen that the top shade **111** extends forward of the display surface **12** by 1 to 6 inches, to reduce the amount of off axis incident light that would cause glare on the display surface **12**. The left side shade **112** extends forward of the display surface **12** by 1 to 6 inches, at the top to about 1 inch at the bottom, to reduce the amount of off-axis incident light that would cause glare on the display surface **12**. The right side shade **113** (not shown) is similarly arranged. The bottom shade **114** extends forward of the display surface **12** by about 1 inch from the display surface **12**.

[0047] It can be seen that the suction cup **90** is attached to the top shade **111** by means of an adjustable structure **120** that allows the physical relationship between the suction cup **90** and the display device **11** to be adjusted to allow appropriate positioning of the display device **11** with respect to the windshield **15**, when the suction cup is used to attach the display device **11** to the windshield **15**.

[0048] The signage system **10** of the present of invention might assume several distinct forms. In the simplest form, the sign would be positioned inside a vehicle to present its

message through the windshield of a vehicle and be programmed by a local programming device such as a computer, through a local wired or wireless connection, so that a message, either stationary or changing, could be displayed by the sign. A local programming device is a programming device that, during programming, is either within or immediately adjacent, the vehicle

[0049] In another form of the system, the system described above could have a wireless connection with sufficient range so that the sign could be programmed by a remote programming device or computer. A remote programming device is a programming device that, during programming, is either within a separate vehicle or structure different from the said vehicle, or at least 3 meters from the said vehicle.

[0050] In another form of the system, the system includes a plurality of vehicles, each one with a visual display device visible through the windshield, and each vehicle including a local programming device that is capable of programming its display device in the associated vehicle so that each vehicle has with identical or different display messages. In the preferred implementation of this version, each visual display would be programmed to have a different and moving signal, and the moving signals on the various display devices would be coordinated so that the message appeared to move in a coordinated fashion across the visual field of the plurality of vehicles windshields. This provides a very dramatic and attractive visual effect.

[0051] In another form of the system, the system includes a plurality of vehicles, each one with a visual display device visible for the windshield, and the system includes a remote central programming device that is capable of programming each display device in each vehicle simultaneously or separately, with identical or different display messages. In the preferred implementation of this version, each visual display would be programmed to have a different and moving signal, and the moving signals on the various display devices would be coordinated so that the message appeared to move in a coordinated fashion across the visual field of the plurality of vehicles windshields. This provides a very dramatic and attractive visual effect.

[0052] While it will be apparent that the illustrated embodiments of the invention herein disclosed are calculated adequately to fulfill the object and advantages primarily stated, it is to be understood that the invention is susceptible to variation, modification, and change within the spirit and scope of the subjoined claims. It is obvious that minor changes may be made in the form and construction of the invention without departing from the material spirit thereof. It is not, however, desired to confine the invention to the exact form herein shown and described, but it is desired to include all such as properly come within the scope claimed.

[0053] The invention having been thus described, what is claimed as new and desire to secure by Letters Patent is:

What I claim as my invention is:

1. A signage system, comprising:

- a) a vehicle having the windshield,
- b) a sign having a visual display surface that is capable of forming illuminated graphic display on the visual display surface, the sign and being mounted for display adjacent the inside surface of the windshield of the vehicle, so that the visual display surface would be visible to observers in front of the vehicle,

c) a message controller adapted to determine the graphic display on the sign, and

d) a message programming device adapted to instruct the message controller concerning the graphic display that the message controller determines for the sign.

2. A signage system as recited in claim 1, wherein the display surface carries a matrix of highly energy efficient illumination devices that, when selectively illuminated, form the graphic display.

3. A signage system as recited in claim 2, wherein the illumination devices are light emitting diodes.

4. A signage system as recited in claim 1, wherein the vehicle includes a battery and a solar panel that provides electric power to the battery to power the sign.

5. A signage system as recited in claim 1, wherein the sign includes a suction cup for holding the sign to the inside of the windshield.

6. A signage system as recited in claim 1, wherein the message controller and the message programming device each include a wireless communication capability that allows the message programming device to communicate wirelessly with the message controller, and thereby program the message controller remotely.

7. A signage system as recited in claim 1, wherein the visual display surface of the sign includes a forwardly directed shade frame that protects the display surface from off axis light and thereby minimizes the glare on the display surface and maximizes the visibility of the graphic display.

8. A signage system as recited in claim 1, wherein the system includes a light sensor to monitor daylight and control the operation time of the visual display.

9. A signage system as recited in claim 1, wherein the system includes a light sensor to monitor daylight and control the intensity of the visual display.

10. A signage system as recited in claim 1, wherein include a highly visible identification number that specifically identifies the visual display device and provides for efficient identification and programming of the device.

11. A signage system, comprising:

- a) a plurality of vehicles, each having a windshield,
- b) a plurality of signs, each having a visual display surface that is capable of forming illuminated graphic display on the visual display surface, each sign and being mounted for display adjacent the inside surface of the windshield of a vehicle, so that the visual display surface would be visible to observers in front of the vehicles,

c) a plurality of message controllers, each adapted to determine the graphic display on a sign, and

d) a message programming device adapted to instruct the message controllers concerning the graphic display that each message controller determines for each sign.

12. A signage system as recited in claim 11, wherein each display surface carries a matrix of highly energy efficient illumination devices that, when selectively illuminated, form the graphic display.

13. A signage system as recited in claim 12, wherein the illumination devices are light emitting diodes.

14. A signage system as recited in claim 11, wherein each vehicle includes a battery and a solar panel that provides electric power to the battery to power the sign.

15. A signage system as recited in claim 11, wherein each sign includes a suction cup for holding the sign to the inside of the windshield.

16. A signage system as recited in claim **11**, wherein each message controller and the message programming device each include a wireless communication capability that allows the message programming device to communicate wirelessly with each message controller, and thereby program each message controller remotely.

17. A signage system as recited in claim **11**, wherein each visual display surface of the sign includes a forwardly directed shade frame that protects the display surface from off axis light and thereby minimizes the glare on the display surface and maximizes the visibility of the graphic display.

18. A signage system as recited in claim **11**, wherein the system includes a light sensor to monitor daylight and control the operation time of the visual display.

19. A signage system as recited in claim **11**, wherein the system includes a light sensor to monitor daylight and control the intensity of the visual display.

20. A signage system as recited in claim **11**, wherein each sign includes a highly visible identification number that specifically identifies the visual display device and provides for efficient identification and programming of the device.

21. A signage system as recited in claim **11**, two of the signs are programmed with different graphic displays, the graphic displays are time coordinated so that the combined graphical display as a dynamic visual effect.

22. A signage system as recited in claim **21**, two of the signs are programmed with different graphic displays, the graphic displays are time coordinated so that the combined graphical display as a dynamic visual effect of the graphic display a moving from one sign to the other.

23. A signage system as recited in claim **21**, two of the signs are programmed with different graphic displays, the graphic displays are time coordinated so that the combined graphical display as a dynamic visual effect of the graphic display a moving from one sign to the other and back again.

24. A signage system as recited in claim **11**, three of the signs are each programmed with different graphic displays, and the graphic displays are time coordinated so that the combined graphical display as a dynamic visual effect of the graphic display a moving from the first sign to the second sign, and then to the third sign.

* * * * *