



US 20060292868A1

(19) **United States**

(12) **Patent Application Publication**
Yoshikawa

(10) **Pub. No.: US 2006/0292868 A1**

(43) **Pub. Date: Dec. 28, 2006**

(54) **SURFACE EMITTING SEMICONDUCTOR LASER**

Publication Classification

(75) Inventor: **Masahiro Yoshikawa**, Kanagawa (JP)

(51) **Int. Cl.**

H01L 21/302 (2006.01)

H01L 21/461 (2006.01)

H01L 21/44 (2006.01)

Correspondence Address:

OLIFF & BERRIDGE, PLC

P.O. BOX 19928

ALEXANDRIA, VA 22320 (US)

(52) **U.S. Cl.** **438/670; 438/717**

(73) Assignee: **Fuji Xerox Co., Ltd.**, Tokyo (JP)

(57)

ABSTRACT

(21) Appl. No.: **11/511,229**

A method of forming a conductive pattern such as an electrode on a compound semiconductor layer includes the steps of forming a first organic layer on the compound semiconductor layer, forming a second layer on the first organic layer, the second layer being resistant to plasma ashing, forming a pattern including a first aperture in the second layer, forming a second aperture in the first organic layer by the plasma ashing of the first organic layer using a mask of the pattern including the first aperture to expose the compound semiconductor layer in the second aperture, depositing a conductive layer over a region including the compound semiconductor layer exposed in the second aperture and the second layer, and forming the conductive pattern on the compound semiconductor layer by a lift-off process.

(22) Filed: **Aug. 29, 2006**

Related U.S. Application Data

(62) Division of application No. 10/629,777, filed on Jul. 30, 2003.

(30) **Foreign Application Priority Data**

Dec. 16, 2002 (JP) 2002-363484

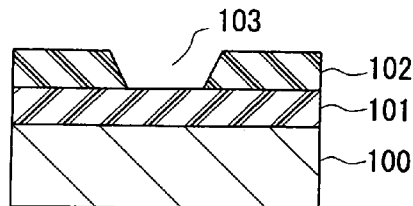
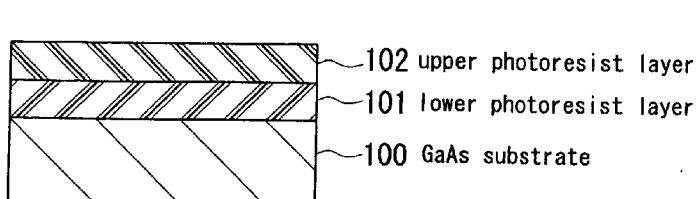

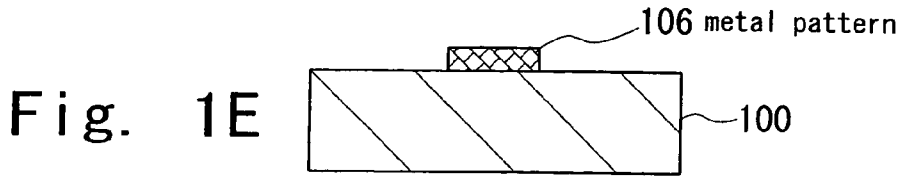
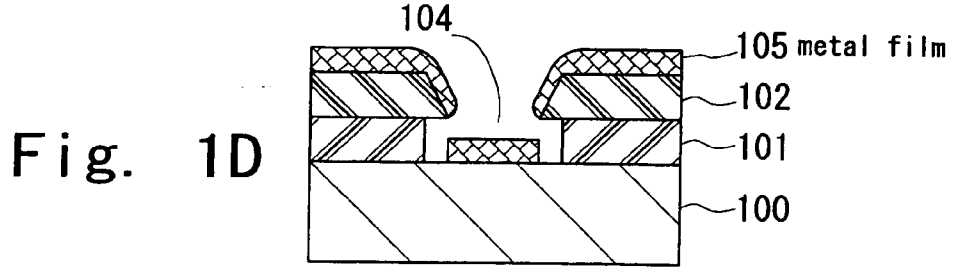
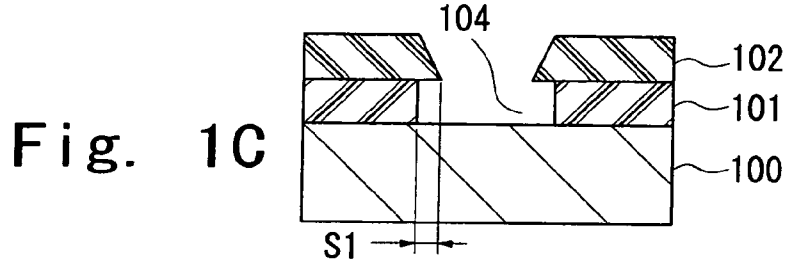
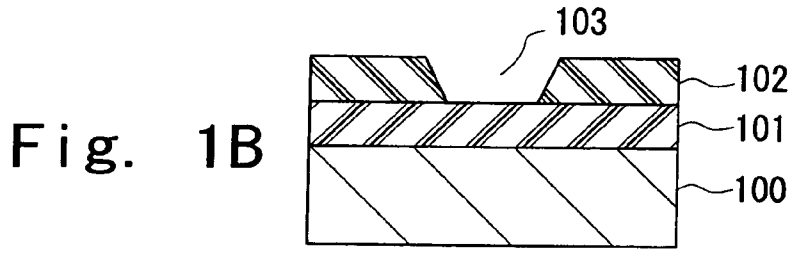
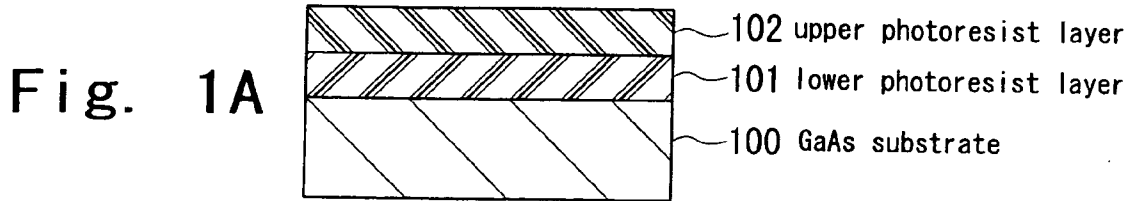

Fig. 2A

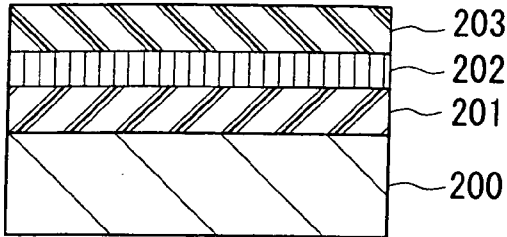

Fig. 2B

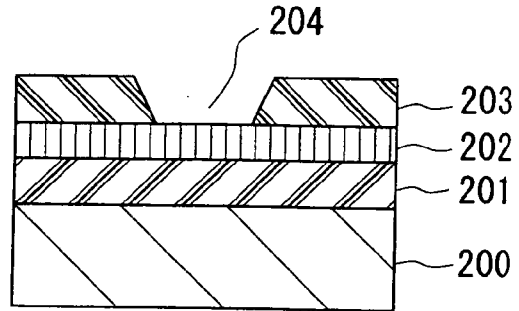

Fig. 2C

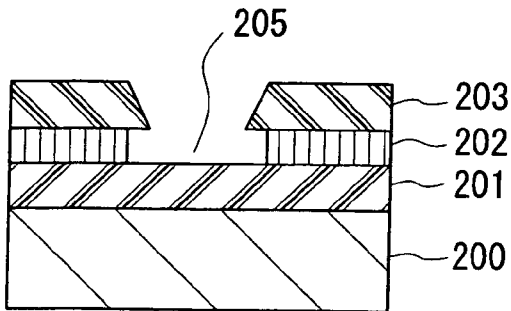

Fig. 2D

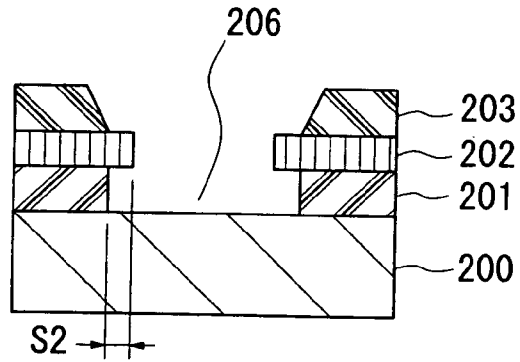

Fig. 2E

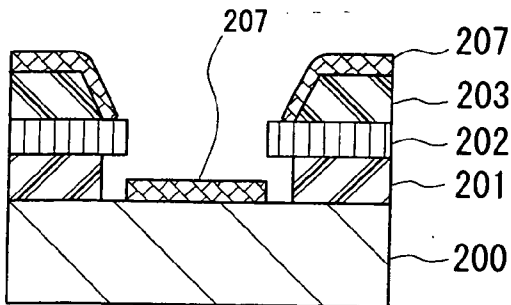

Fig. 2F

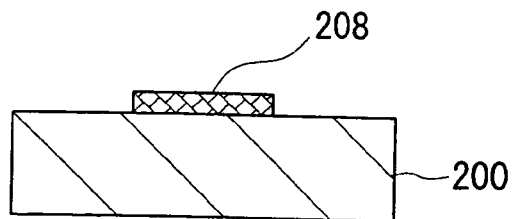

Fig. 3

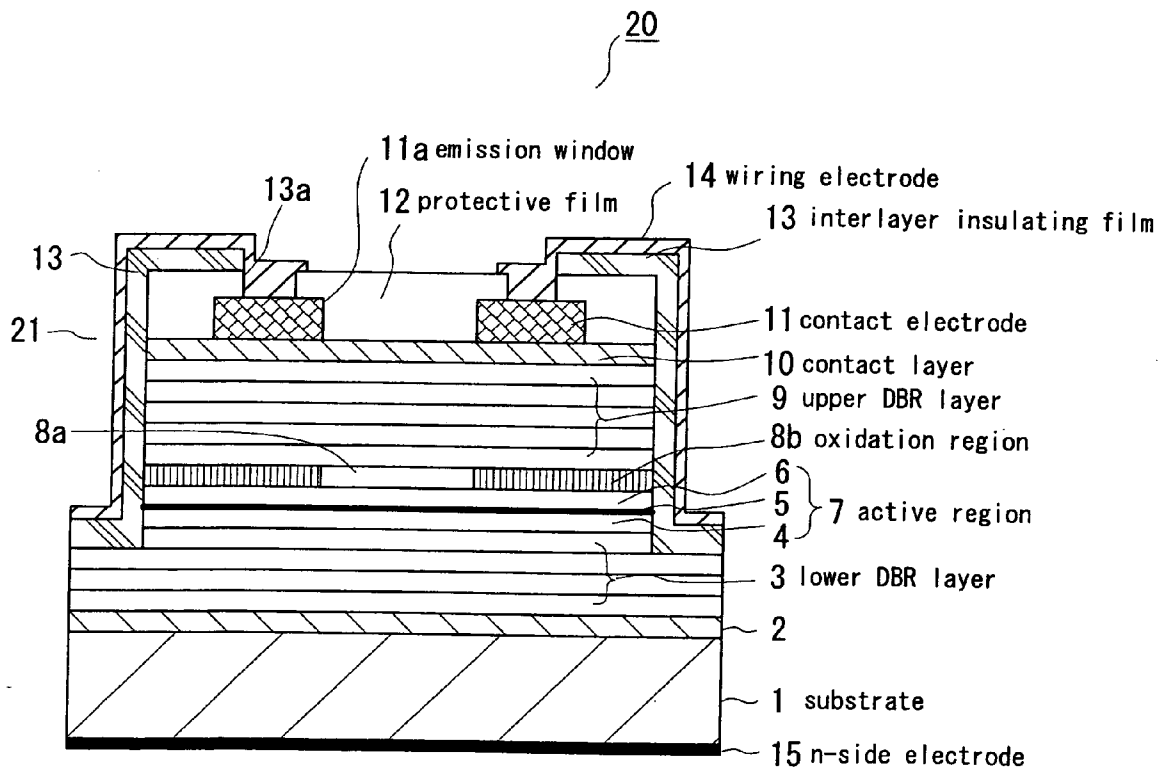

Fig. 4A

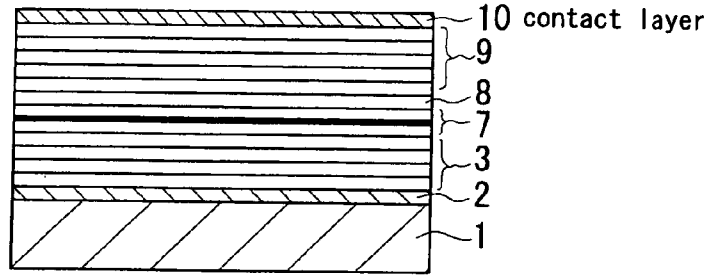

Fig. 4B

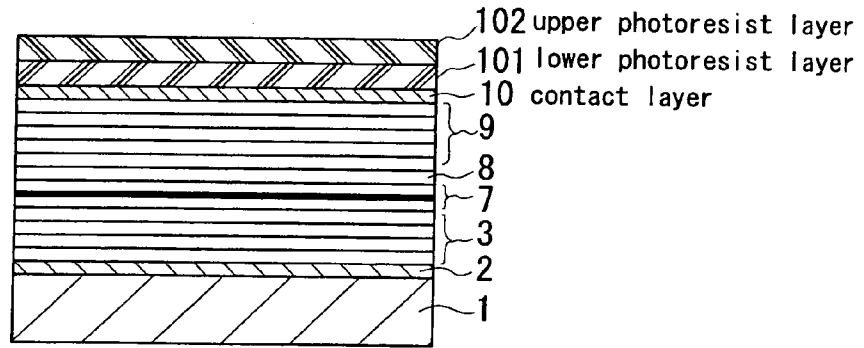

Fig. 4C

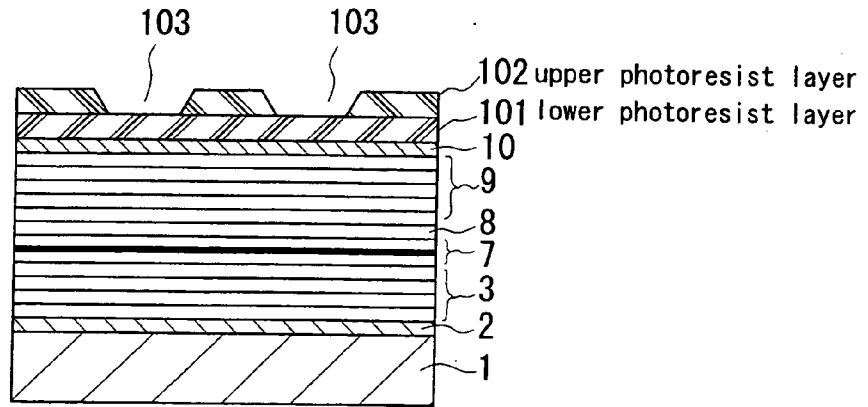

Fig. 5D

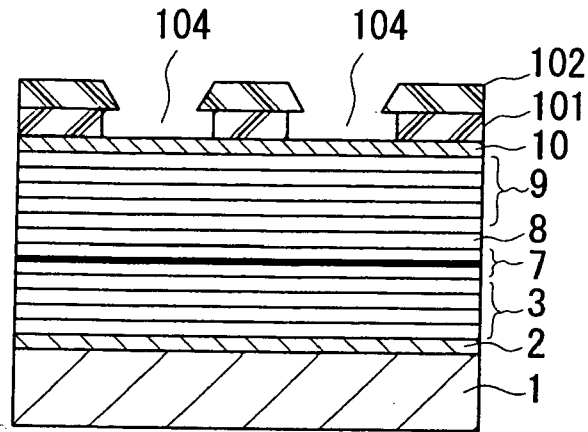

Fig. 5E

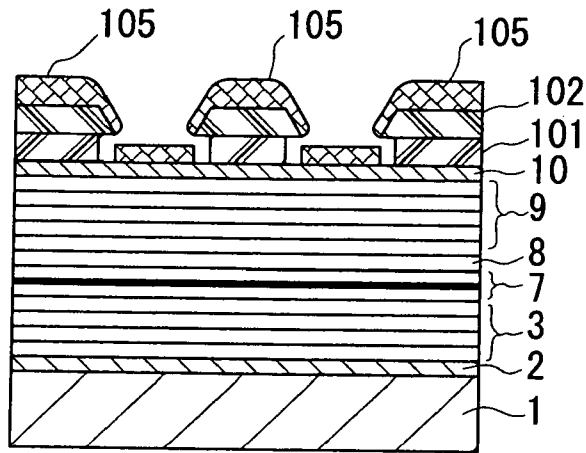
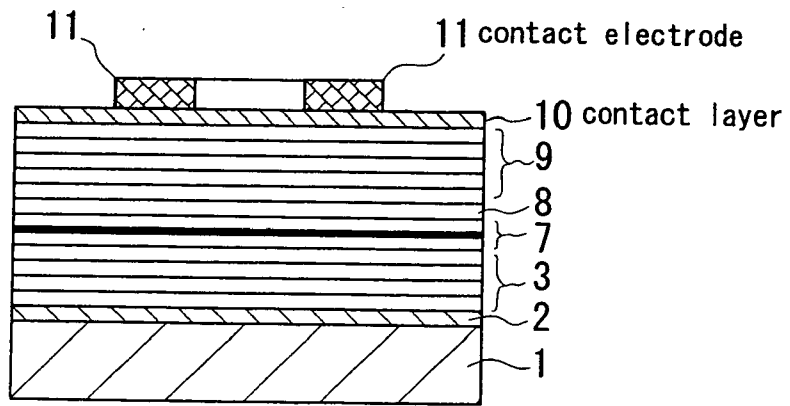

Fig. 5F



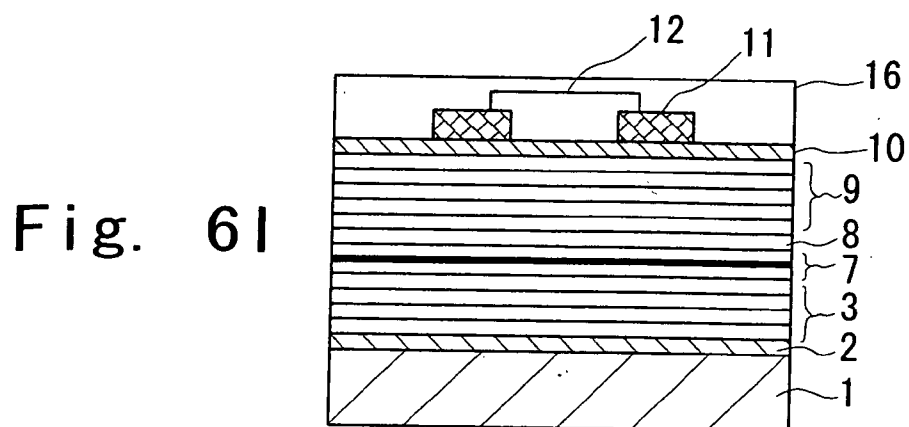
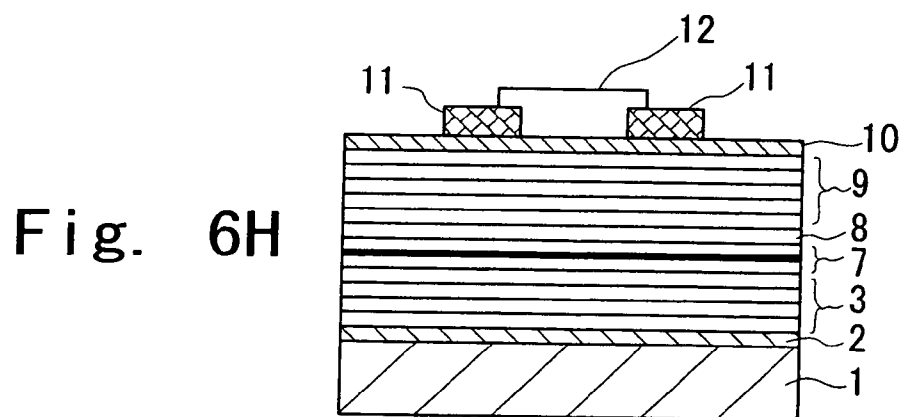
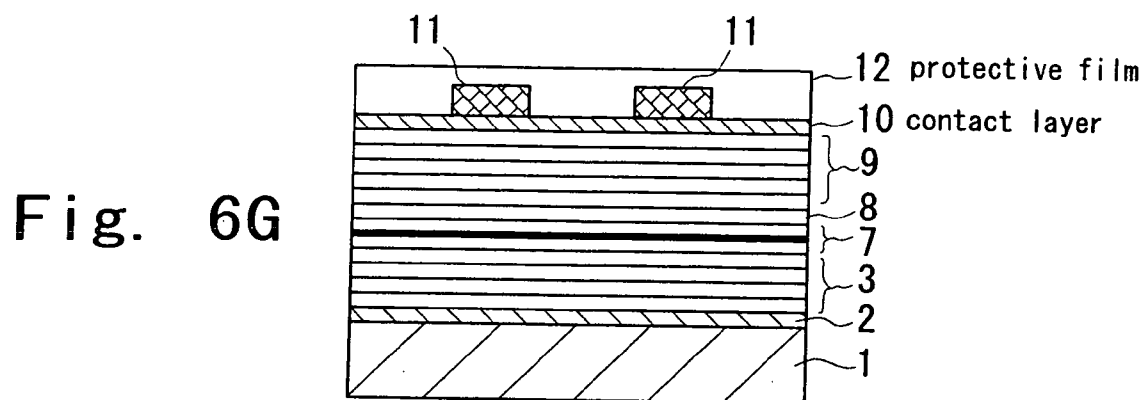

Fig. 7J

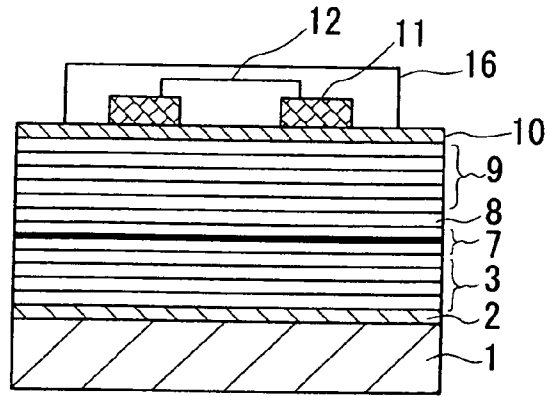

Fig. 7K

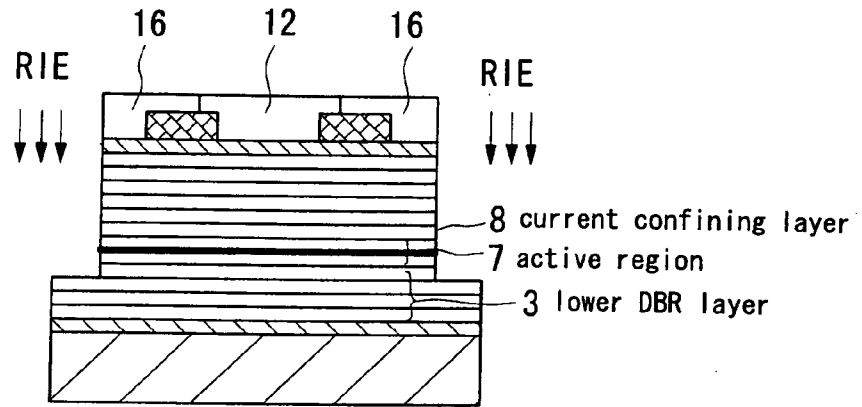

Fig. 7L

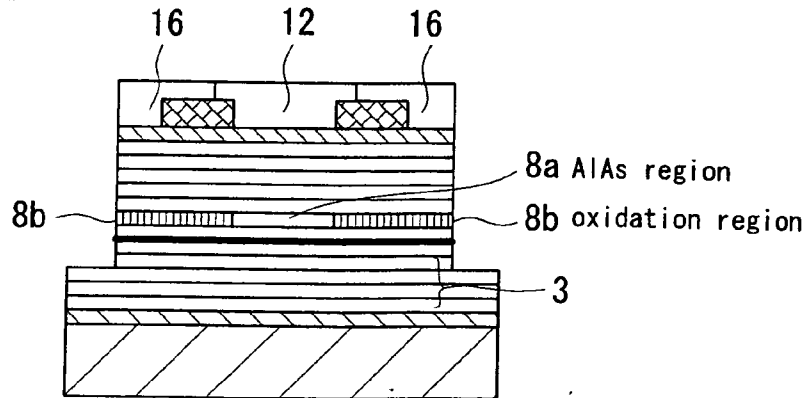

Fig. 8M

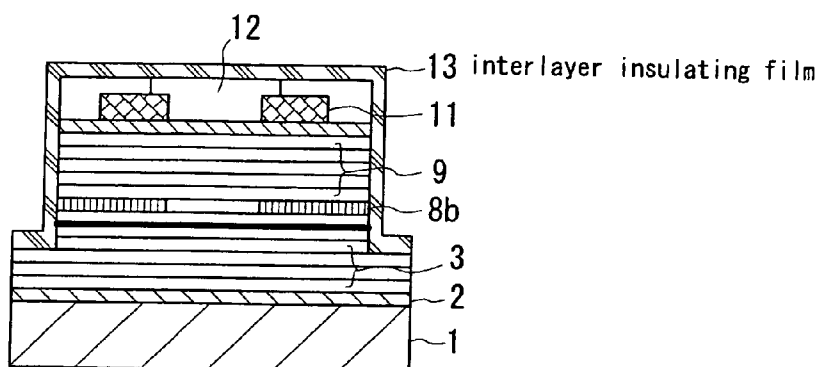

Fig. 8N

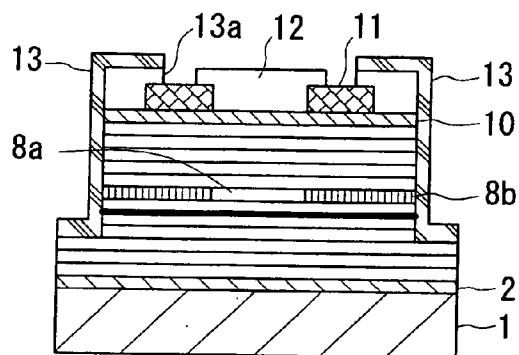

Fig. 8O

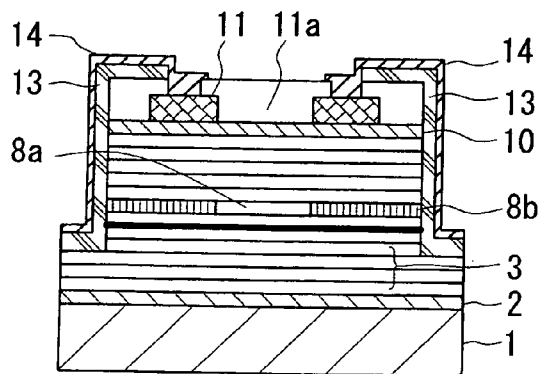
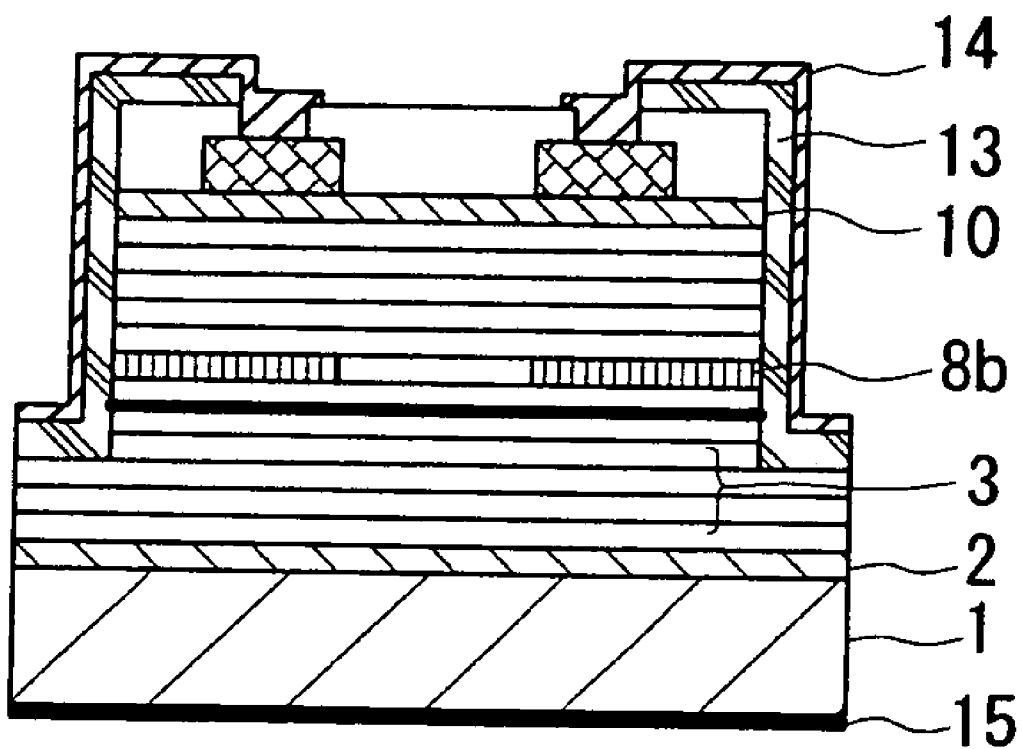
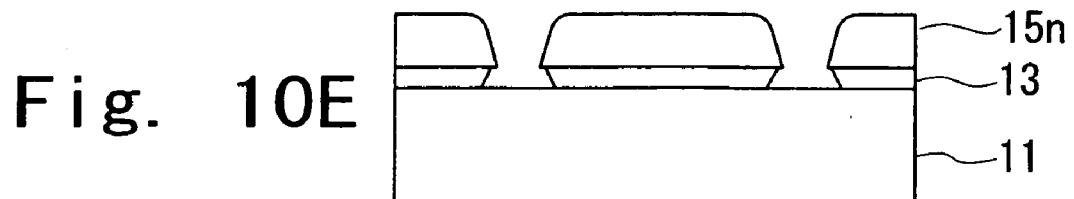
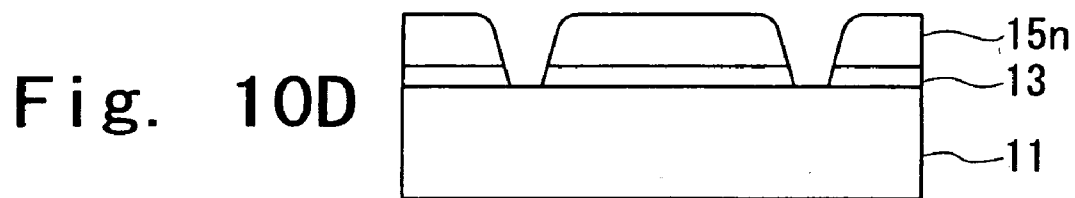
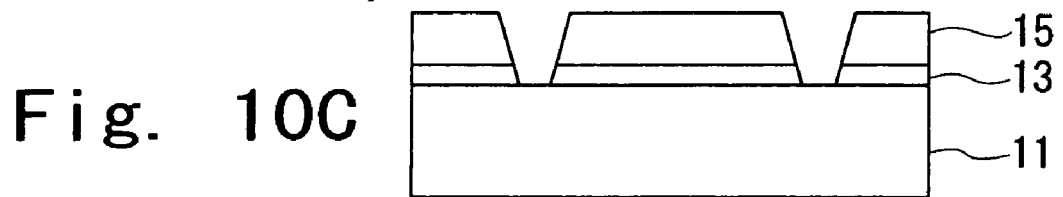
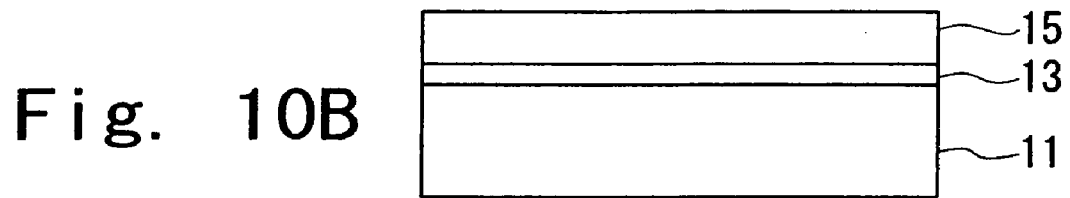
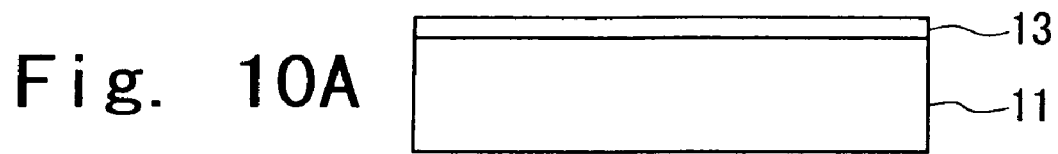

Fig. 9P





SURFACE EMITTING SEMICONDUCTOR LASER

[0001] This is a Division of application Ser. No. 10/629, 777 filed Jul. 30, 2003. The disclosure of the prior applications is hereby incorporated by reference herein in its entirety.

BACKGROUND OF THE INVENTION

[0002] 1. Field of the Invention

[0003] The present invention relates to a method of forming a conductive pattern such as electrodes on a compound semiconductor layer, and more particularly, to a method of forming a fine electrode pattern using a lift-off process.

[0004] 2. Description of the Related Art

[0005] In a technical field of an optical communication and optical recording, the demand of using a surface emitting semiconductor laser (Vertical Cavity Surface Emitting Laser Diode) has been increased because of facilitation of the two-dimensional light source array. The surface emitting semiconductor laser device is typically made of compound semiconductor layers such as GaAs, AlGaAs and so on, and generally the lift-off process is employed to form electrodes and wirings with a predetermined shape and size.

[0006] For example, Japanese Laid-Open Patent Application No. 10-154707 discloses a lift-off process. As shown in FIGS. 10A to 10E, an upper photoresist layer 15 is formed on a lower photoresist layer 13 and the upper photoresist layer 15 is insolubilized after patterning of two photoresist layers. Then the lower photoresist layer 13 is dissolved to form an undercut for the upper photoresist layer 15n. After that, a conductive film 20 is formed by the lift-off process. By the formation of the undercut, the needed time for the lift-off process is shortened and the generation of flashes around the conductive layer 20 is prevented.

[0007] However, there are following problems to be resolved in forming the pattern by the lift-off process as shown in the above application. When the electrodes and/or the metal wirings pattern are formed on the compound semiconductor layer such the surface emitting semiconductor laser device, the use of an alkali developer for forming the undercut in the lower resist layer causes the contact with the surface of the compound semiconductor layers and causes them to be etched. The compound semiconductor layer, e.g. GaAs, has a surface that is chemically weak, and therefore the etching progresses clearly memorably and the life time of devices may be shortened by the surface damages caused by the etching and the performances may be affected by the damages. Furthermore, when a p-side electrode which defines an emission window for the laser light is formed the contact layer such GaAs in the surface emitting semiconductor laser, the etching of a contact layer has an adverse effect on the optical characteristics or properties of the laser light.

SUMMARY OF THE INVENTION

[0008] The present invention has been made in view of the above circumstances and provides a method of forming a conductive pattern of electrodes or wirings in which the surface damages on the compound semiconductor layer is prevented as far as possible.

[0009] Furthermore, the present invention provides a method of forming a conductive pattern in which a fine pattern of electrode or wirings can be formed on the compound semiconductor layer by means of the lift-off process.

[0010] Furthermore, the present invention provides a method of manufacturing the surface emitting semiconductor laser using the method of forming the conductive pattern.

[0011] Furthermore, the present invention provides a surface emitting semiconductor laser and its manufacturing method in which the harmful effects on the optical characteristics of laser light are inhibited and the life time of device is improved.

[0012] According to an aspect of the present invention, a method of forming a conductive pattern such as an electrode on a compound semiconductor layer has forming a first organic layer on the compound semiconductor layer, forming a second layer on the first organic layer, the second layer being resistant to a plasma ashing, forming a pattern including a first aperture in the second layer, forming a second aperture in the first organic layer by the plasma ashing of the first organic layer using a mask of the pattern including the first aperture to expose the compound semiconductor layer in the second aperture, depositing a conductive layer over a region including the compound semiconductor layer exposed in the second aperture and the second layer, forming the conductive pattern on the compound semiconductor layer by a lift-off process.

[0013] According to another aspect of the present invention, a method of forming a conductive pattern over a compound semiconductor layer has forming a first organic layer on the compound semiconductor layer, forming an inorganic layer on the first organic layer, forming a second organic layer on the inorganic layer, forming a first pattern including a first aperture in the second organic layer, forming a second pattern including a second aperture in the inorganic layer by etching the inorganic layer using a mask of the first pattern including the first aperture, forming a third aperture in the first organic layer by a plasma ashing of the first organic layer using a mask of the second pattern including the second aperture to expose the compound semiconductor layer in the third aperture, depositing a conductive film over a region including the compound semiconductor layer exposed in the third aperture and the second organic layer, and forming the conductive pattern on the compound semiconductor layer by a lift-off process.

[0014] According to another aspect of the present invention, a method of manufacturing a surface emitting semiconductor laser, the surface emitting semiconductor laser including a first semiconductor mirror layer of first conductivity type over a substrate, a current confining layer over the first semiconductor mirror layer, an active region over the first semiconductor mirror layer, a second semiconductor mirror layer of second conductivity type over the active region and a contact layer including a compound semiconductor layer over the second semiconductor mirror layer, the method has following steps; forming a first organic layer on the contact layer, forming a second layer on the first organic layer, the second layer being resistant to a plasma ashing, forming a pattern including a first aperture in the second layer, forming a second aperture in the first organic layer by the plasma ashing of the first organic layer using a mask of the pattern including the first aperture to expose the contact

layer in the second aperture, depositing a conductive layer over a region including the contact layer exposed in the second aperture and the second layer, and forming a conductive pattern on the contact layer by a lift-off process.

[0015] According to another aspect of the present invention, a surface emitting semiconductor laser has a substrate, a first mirror formed over the substrate, the first mirror including semiconductor layers of first conductivity type, a second mirror formed over the substrate, the second mirror including semiconductor layers of a second conductivity type, a active region disposed between the first and second mirrors, a current confining layer disposed between the first and second mirrors, a compound semiconductor layer formed over the second mirror, and an electrode formed on the compound semiconductor layer. A surface roughness of the compound semiconductor layer in at least a peripheral portion of the electrode is not more than 5 nm.

BRIEF DESCRIPTION OF THE DRAWINGS

[0016] Preferred embodiments of the present invention will be described in detail based on the following figures, wherein:

[0017] FIGS. 1A to 1E show steps for forming a metal pattern including electrode-like according to a first embodiment of the present invention;

[0018] FIGS. 2A through 2F show a step for forming a metal pattern including electrode-like according to a second embodiment of the present invention;

[0019] FIG. 3 shows a cross sectional view of the surface emitting semiconductor laser;

[0020] FIGS. 4A to 4C show steps for manufacturing the surface emitting semiconductor laser according to a third embodiment of the present invention;

[0021] FIGS. 5D to 5F show steps for manufacturing the surface emitting semiconductor laser according to the third embodiment of the present invention;

[0022] FIGS. 6G to 6I show steps for manufacturing the surface emitting semiconductor laser according to the third embodiment of the present invention;

[0023] FIGS. 7J to 7L show steps for manufacturing the surface emitting semiconductor laser according to the third embodiment of the present invention;

[0024] FIGS. 8M to 8O show steps for manufacturing the surface emitting semiconductor laser according to the third embodiment of the present invention;

[0025] FIG. 9P shows steps for manufacturing the surface emitting semiconductor laser according to the third embodiment of the present invention;

[0026] FIGS. 10A to 10E show steps for forming the conductive pattern including electrode-like in a prior art.

DESCRIPTION OF THE PREFERRED EMBODIMENTS

[0027] A description will now be given of a method of forming a conductive pattern according to an embodiment of the present invention. FIG. 1 shows the method of forming an electrode on a compound semiconductor layer according to the first embodiment of the present invention.

[0028] In FIG. 1, a photoresist is provided on a GaAs substrate 100. The thickness of the photoresist is approximately 1.0~2.0 μm , which forms a lower photoresist layer 101. Subsequently, the lower photoresist layer 101 is subjected to a baking process at an appropriate temperature, e.g. 130° C. By the baking process, the photoresist is insolubilized and the photoresist turns to be resistant to a developer.

[0029] Next, a photoresist which is resistant to an oxygen plasma is formed on the lower photoresist layer 101. For example, the photoresist may be a photoresist containing silicon (FH-SP: production of Fuji Shashin Film Arch Co.). The thickness of the photoresist is approximately 1 μm , which forms an upper photoresist layer 102.

[0030] The upper photoresist layer 102 is subjected to a pre-baking process, for example 90 degree Celsius, and to an exposure process using a desirable mask pattern. Then the photoresist is developed by an alkali developer, as shown in FIG. 1B, a pattern including an aperture 103 (hereinafter referred to as aperture pattern) is formed in the upper photoresist layer 102.

[0031] Subsequently, as shown in FIG. 1C, the exposed lower photoresist layer 101 is ashed by the oxygen plasma by the oxygen plasma etcher using a mask of the aperture pattern 103 of the upper photoresist layer 102, thereby the exposed region being removed. By selecting a suitable ashing time, an aperture pattern 104, which is similar to the aperture pattern 103 in the upper photoresist layer 102, is formed in the lower photoresist layer 101. Simultaneously, the upper photoresist layer 102 is not removed at all since it is resistant to the oxygen plasma. Also, the aperture pattern 104 formed in the lower photoresist 101 is removed laterally by the oxygen plasma ashing, which forms an undercut structure to the upper photoresist layer 102. The distance S1 of the undercut is approximately 1 μm .

[0032] As shown in FIG. 1D, a metal film is deposited or vaporized over a region, which includes the upper photoresist layer 102 and the substrate exposed by the aperture pattern 104. The metal film 106 is preferably placed within the aperture pattern 104 because the aperture pattern 104 is made to the undercut structure to the upper photoresist layer 102.

[0033] As shown in FIG. 1E, the lower photoresist layer 101 and the upper photoresist layer 102 are dissolved for removing, and a conductive pattern 106 such as an electrode and wiring pattern is formed on the surface of the substrate 100 by the lift-off process.

[0034] Now the second embodiment of the present invention will be explained. FIG. 2 shows steps of forming an electrode of the second embodiment of the present invention. As shown in FIG. 2A, a photoresist is provided on a GaAs substrate 200 for forming a lower photoresist layer 201 with a thickness of approximately 1.0~2.0 μm . Then the lower photoresist 201 is baked at a desirable temperature. After that, an inorganic film 202, for example ITO, which is resistant to the oxygen plasma, is deposited on the entire surface with a thickness of approximately 1 μm . Additionally, a photoresist is coated on the inorganic film 202 to form an upper photoresist layer 203 with a thickness of approximately 1 μm , and then the upper photoresist layer 203 is subjected to the pre-baking process.

[0035] As shown in FIG. 2B, an aperture pattern 204 is formed after an exposure process made to the upper photoresist layer 203 using a desirable mask pattern. After that, a post baking process is done.

[0036] Next, as shown in FIG. 2C, the inorganic film 202 is etched by an etchant such as hydrochloric acid using a mask of the aperture pattern 204 of the upper photoresist layer 203. The region exposed by the upper photoresist layer 203 is removed off and an aperture pattern 205 is formed in the inorganic film 202.

[0037] Subsequently, the lower photoresist layer 201 is subject to the ashing process of oxygen plasma by the oxygen plasma etcher using a mask of the aperture pattern 205 of the inorganic film 202. The inorganic film 202 is not etched off substantially because of being resistant to the oxygen plasma or oxygen radical. By performing the oxygen plasma ashing for a suitable time, an aperture pattern 206, which is similar to the aperture pattern 205 of the inorganic film 202, is formed in the lower photoresist layer 201, this resulting in a preferable undercut structure. In this embodiment, the lateral undercut distance S2 of the lower photoresist layer 201 is approximately 1 μm .

[0038] As shown in FIG. 2E, a metal film 207 is deposited on the entire surface of the substrate. The metal film 207 is placed on the upper photoresist layer 203 and on the substrate 200 exposed by the aperture 206 of the lower photoresist layer 201.

[0039] Finally, the photoresist layers and inorganic film are removed by the lift-off process for forming the metal pattern 208

[0040] As described above, by forming the metal pattern using the lift off process as shown in FIGS. 1 and 2, the surface of the substrate is not exposed and not etched by the developer and is kept flat so that the desirable metal wiring and/or electrode pattern can be formed. It is appreciated that a device having good characteristics can be fabricated.

[0041] Now a method of manufacturing a surface emitting semiconductor laser which is applied by the above process in FIG. 1 will be explained. FIG. 3 shows a cross sectional view of the surface emitting semiconductor laser and FIGS. 4 to 9 show the steps for manufacturing it.

[0042] The surface emitting laser 20 of the embodiment is a type of selective oxidation surface emitting laser, which includes a laser element 20 of a cylindrical mesa structure (post structure or pillar structure). In the drawing, a protective film on the laser element 20 or mesa structure 21 and a bonding pad extended from a metal contact layer are omitted.

[0043] Referring to FIG. 4, 1 is a GaAs substrate of n type, 2 is a GaAs buffer layer of n type formed on the substrate 1. 3 is a lower DBR(Distributed Bragg Reflector) layer of n type. 7 is an active region formed on the lower DBR layer 3. The active region 7 is composed of laminated layers, which include an undoped lower spacer layer 4, undoped quantum well layer 5, and undoped upper spacer layer 6. 8 is a current confining layer formed on the active region 7. The current confining layer 8 includes an AlAs portion 8a which defines a circular aperture at the center and includes an oxidized region 8b around the AlAs portion 8a. The oxidized region 8b confines a current and light which pass

through there. 9 is an upper DBR layer of p type formed on the current confining layer 8. 10 is a GaAs contact layer of p type formed on the upper DBR layer 10. 11 is a p-side contact electrode of annular-shape or ring-shape on the contact layer 10, which defines an emission window 11a for the laser light. 12 is a protective film for protecting the emission window 11a, formed on the contact electrode 11. 13 is an interlayer insulating film 13 which covers a top end, side and bottom of the mesa 21. 14 is a p-side wiring electrode, which is formed on the interlayer insulating film 13 and is connected to the contact electrode 11 through a contact hole 13a

[0044] The emission window 11a is a circular shape and its center coincides with an optical axis which extends through a center of the mesa 21 and extends in a vertical direction with respect to the substrate 1. The center of AlAs portion 8a of the current confining layer 8 also coincides with the optical axis substantially. That is, the AlAs portion 8a and the emission window 11a are aligned mutually.

[0045] Now the manufacturing method of the surface emitting semiconductor laser 20 will be explained. In FIG. 4A, semiconductor layers are formed on the substrate 1 by MOCVD (Metalorganic Chemical Vapor Deposition) or MBE(Molecular Beam Epitaxy). The GaAs buffer layer 2 of n type, the lower DBR layer 3, the active region 7 which includes the lower spacer layer 4 of undoped $\text{Al}_{0.6}\text{Ga}_{0.4}\text{As}$, a quantum well layer 5 having undoped GaAs well layer and having undoped $\text{Al}_{0.3}\text{Ga}_{0.7}\text{As}$ barrier layer and the upper spacer layer 6 of undoped $\text{Al}_{0.6}\text{Ga}_{0.4}\text{As}$, the upper DBR layer 9 and GaAs contact layer 10 of p type are sequentially laminated over the substrate 1.

[0046] The lower DBR layer 3 is laminated by 35.5 pairs or cycles of n-type $\text{Al}_{0.9}\text{Ga}_{0.1}\text{As}$ layer and n-type $\text{Al}_{0.3}\text{Ga}_{0.7}\text{As}$ layer alternately. Each layer is $\lambda/4 n_r$ thick where λ is oscillating wavelength and n_r is refractive index of medium. The carrier concentration of the lower DBR layer 3 is $2 \times 10^{18} \text{ cm}^{-3}$ after silicon dopant is doped. While the upper DBR layer 9 is laminated by 23 cycles or pairs of p-type $\text{Al}_{0.9}\text{Ga}_{0.1}\text{As}$ and p-type $\text{Al}_{0.15}\text{Ga}_{0.85}\text{As}$ alternately. Each layer is $\lambda/4 n_r$ thick where λ is oscillating wavelength and n_r is refractive index of medium. The carrier concentration of the upper DBR layer 9 is $2 \times 10^{18} \text{ cm}^{-3}$ after carbon dopant is doped.

[0047] A p-type AlAs layer 8, which is in place of P type $\text{Al}_{0.9}\text{Ga}_{0.1}\text{As}$ and is served as control layer, is interposed at the lowest layer within the upper DBR layer 9. The AlAs layer 8 is $\lambda/4 n_r$ thick and its carrier concentration is $2 \times 10^{20} \text{ cm}^{-3}$ after carbon dopant is doped. A transition region which has a medium aluminum composition ratio may be interposed between $\text{Al}_{0.9}\text{Ga}_{0.1}\text{As}$ layer and $\text{Al}_{0.15}\text{Ga}_{0.85}\text{As}$ of the lower DBR layer 3 and upper DBR layer 9. The P type GaAs contact layer 10 is 20 nm thick and its carrier concentration is $1 \times 10^{18} \text{ cm}^{-3}$.

[0048] As shown in FIG. 4B, the lower photoresist layer 101 with thickness of 1.0 to 2.0 μm is formed on the contact layer 10 and it is baked at a desirable temperature, e.g. 130° C., which makes the lower photoresist layer 101 insolubilized.

[0049] The upper photoresist 102 including silicon with an approximately 1 μm thickness is formed on the lower photoresist layer 101 and is pre-baked. After that, the upper

photoresist layer **102** is subjected to the exposure process using a desired mask pattern and is patterned to form the aperture pattern **103** as shown in **FIG. 4C** using Alkali developer. Simultaneously, the lower photoresist **101** is not dissolved because it is insolubilized to the alkali developer. And then the post-bake is performed.

[0050] As shown in **FIG. 5D**, the exposed lower photoresist layer **101** is ashed by the oxygen plasma by the oxygen plasma etcher using the mask of the pattern **103** of the upper photoresist layer **102** and the aperture pattern **104** which is in shape of an undercut is formed in the lower photoresist layer **101**. The upper photoresist layer **102** is not removed at all since the resist including the silicon gives the property of resistant to the oxygen plasma.

[0051] As shown in **FIG. 5E**, a metal film **105** is deposited over a region including the upper photoresist layer **102** and the contact layer **10** exposed by the aperture pattern **104**. Since the second aperture pattern **104** is made to the undercut structure, the metal pattern **105** can be placed within the second aperture pattern **104**.

[0052] Subsequently, as shown in **FIG. 5F**, the lift-off process is done and the contact electrode **11** is formed on the surface of the contact layer **10**. The electrode pattern **11** is inverted from the aperture pattern **104** and turns to p-side contact electrode **11**. The p-side contact electrode **11** has a ring or annular shape and its inner diameter defines the emission window **11a** for the laser light. For example, the material of the contact electrode **11** may be selected from at least one of Au, Pt, Ti, Ge, Zn, Ni, In, W and ITO.

[0053] Next, the protective film **12** is formed on the contact layer **10** including the p-side contact electrode **11** by PCVD (plasma-assisted chemical vapor deposition) as shown in **FIG. 6G**. For example, SiON, silicon oxide nitride, is deposited to a thickness of 250 nm.

[0054] As shown in **FIG. 6H**, the protective film **12** where a photoresist pattern is not covered on is removed. The photoresist pattern is prepared by the photolithographic process. The patterned protective film **12** is thus formed on the contact electrode **11**.

[0055] Next, as shown in **FIG. 6I**, a silicon nitride mask **16** is deposited to a thickness of 820 nm on the contact layer **10** including the contact electrode **11** and the protective film **12**, for forming the mesa.

[0056] As shown in **FIG. 7J**, by using a photoresist mask pattern prepared photolithographically, the mask **16** is patterned at predetermined size.

[0057] As shown in **FIG. 7K**, the semiconductor layers are etched using the mask **16** until a part of the lower DBR layer **3** is exposed and the mesa is formed. The etching is a reactive ion etching (RIE) using trichloride boron and chlorine.

[0058] Next, as shown in **FIG. 7L**, using the wet type of oxidation furnace introducing water vapor, the AlAs layer **8** is exposed in water vapor and heated at 360 degree Celsius which causes the selective oxidation of the AlAs layer **8** from the sidewall of the mesa, and the oxidation region **8b** is formed.

[0059] Next, as shown in **FIG. 8M**, the interlayer insulating film **13** is formed on the mesa structure so as to cover

the upper surface, side, and bottom thereof. The interlayer insulating film **13** is deposited to a thickness of 800 nm by PCVD.

[0060] As shown in **FIG. 8N**, by using a photoresist mask pattern prepared by the photo lithograph, the interlayer insulating film **13** is subjected to the dry etching and the entire surface of the protective film **12** is exposed and a part of the mask **16** is removed. The etching gases are a mixture of SF₆ and O₂ which have a selectivity in etching. By this etching, the contact hole **13a** is formed so as to expose a part of the p-side contact electrode **11**. After that the photoresist mask pattern is removed.

[0061] As shown in **FIG. 8O**, the wiring electrode **14** is patterned into a predetermined size and shape by the lift-off process after wiring materials, e.g., a laminate metal of Ti and Au, is deposited thereon. The center portion of the wiring electrode **14** on the upper face of the mesa is removed. The removed size may be larger than the emission window **11a** defined by the contact electrode **11**, and the wiring electrode **14** is contacted with the contact electrode **11** through the contact hole **13a**.

[0062] The n-type GaAs substrate **1** is then polished from the backside thereof until it reaches a thickness of 200 nm. As shown in **FIG. 9P**, materials for forming n-side electrode **15** are deposited on the backside of the n-type GaAs substrate **1**. For example, a laminate of Au/Ge/Ni/Au may be used for the n-side electrode.

[0063] As explained above, it is possible to form the desired shape of the p-side contact electrode **11** on the contact layer **10** and to prevent the surface of the contact layer **10** at the contact electrode and its around from being etched by the developer. Thus, the damage of the emission window for the laser light can be reduced considerably, the characteristics of the laser light are stabilized and highly reliable surface emitting semiconductor laser can be obtained.

[0064] The preferable embodiment of the present invention is described above in detail, however, the present invention is not limited to the specifically disclosed embodiments, and other embodiments, variations and modifications may be made without departing from the scope of the present invention.

[0065] For example, the above embodiment shows the metal pattern that is formed over the GaAs substrate and GaAs semiconductor layers, however, other materials of compound semiconductor substrate and layers may be used. Other conductive materials for forming the electrodes may be used.

[0066] The above embodiment exemplifies the use of the oxygen plasma (oxygen radical) in the plasma ashing, however, other charged particles and the ultraviolet light may be added. Furthermore, although the above embodiment exemplifies two layered photoresist structure and two layered photoresist structure interposing the inorganic layer, another combination of layers which is resistant to and is not resistant to the plasma ashing may be used. Alternatively, another combination of layers which has a selectivity and non-selectivity in plasma ashing or etching may be used.

[0067] As explained the above, according to the present invention, the etching of the compound semiconductor layer

by the developer described in the prior art can be prevented and the desirable conductive pattern can be formed on the compound semiconductor layer in maintaining a plane and clean surface of the compound semiconductor layer because the aperture pattern on the compound semiconductor layer is formed by the plasma ashing when the conductive pattern is formed on the compound semiconductor layer. By applying the process of the present invention with the manufacturing process of the surface emitting semiconductor laser using the compound semiconductor layers, it is possible to make the desirable pattern of the contact electrode on the compound semiconductor layers, consequently, the damage on the surface of the compound semiconductor layers can be reduced considerably and the operation of laser light is stabilized and the reliability can be improved.

[0068] Finally, the aforementioned description of the present invention is summarized as follows.

[0069] According to one aspect of the invention, a method of forming a conductive pattern such as an electrode on a compound semiconductor layer includes forming a first organic layer on the compound semiconductor layer, forming a second layer on the first organic layer, the second layer being resistant to a plasma ashing, forming a pattern including a first aperture in the second layer, forming a second aperture in the first organic layer by the plasma ashing of the first organic layer using a mask of the pattern including the first aperture to expose the compound semiconductor layer in the second aperture, depositing a conductive layer over a region including the compound semiconductor layer exposed in the second aperture and the second layer, and forming the conductive pattern on the compound semiconductor layer by a lift-off process.

[0070] According to this, the surface of the compound semiconductor layer is prevented from contacting with a solution such as an alkali developer-like, thus the surface etching is preferably inhibited and the surface damage by the etching can be reduced.

[0071] According to another aspect of the invention, a method of forming a conductive pattern over a compound semiconductor layer includes forming a first organic layer on the compound semiconductor layer, forming an inorganic layer on the first organic layer, forming a second organic layer on the inorganic layer, forming a first pattern including a first aperture in the second organic layer, forming a second pattern including a second aperture in the inorganic layer by etching the inorganic layer using a mask of the first pattern including the first aperture, forming a third aperture in the first organic layer by a plasma ashing of the first organic layer using a mask of the second pattern including the second aperture to expose the compound semiconductor layer in the third aperture, depositing a conductive film over a region including the compound semiconductor layer exposed in the third aperture and the second organic layer, and forming the conductive pattern on the compound semiconductor layer by a lift-off process.

[0072] According to this, the surface of the compound semiconductor layer is significantly prevented from the damages by the etching, which provides the desirable electrodes and/or wirings on the surface.

[0073] In a preferable first method, a photoresist is coated on a GaAs substrate (or GaAs layer) to form an lower resist

layer of an organic layer. Then the lower photoresist is insolubilized to the developer after the baking process. Next, a photoresist which is resistant to an oxygen plasma is formed as an upper photoresist layer. The upper photoresist layer is patterned by a desirable mask pattern prepared by the photo lithographic process. Next, using an oxygen plasma either, the lower photoresist layer exposed by mask pattern of the upper photoresist layer is ashed by the oxygen plasma for patterning the lower photoresist layer. By executing the oxygen plasma ashing at desirable time, the pattern which is similar to the pattern of the upper photoresist layer is formed in the lower photoresist layer. After that, a conductive film such as a metal is deposited on an entire surface. Finally, the lower photoresist layer is subjected to the lift-off process to form electrodes and/or metal wirings on the substrate surface.

[0074] In a preferable second method, a photoresist is coated on a GaAs substrate (or GaAs layer) to form an lower resist layer as an organic layer. Next, the lower photoresist layer is solidified by the baking process-like and an inorganic layer which is resistant to the oxygen plasma is deposited on an entire surface. Additionally, a photoresist layer is coated to form an upper photoresist layer. After that, the upper photoresist layer is patterned using a desirable mask prepared by a photo lithograph process. Next, the inorganic layer is etched using the mask pattern of the upper photoresist layer. Next, the lower photoresist layer is ashed by the oxygen plasma using the mask pattern of the inorganic layer. By carrying out of the oxygen plasma process at a suitable time, a pattern which is same pattern or an undercut pattern of the upper photoresist layer is formed in the lower resist layer. Next, a conductive film such as metal-like is deposited on an entire surface. Finally, the lower photoresist layer is lifted off to make metal electrodes or metal wirings on the substrate surface.

[0075] Since the conductive pattern such as metal or wiring is formed on the surface of the compound semiconductor layer (including the substrate) such as GaAs by using the process according to the present invention, the surface of the compound semiconductor layer is inhibited from contacting with the alkali developer-like directly during the manufacturing processes. Consequently, the formation of metal wirings or electrodes can be realized without etching or damaging the substrate surface such as GaAs, whose surface is chemically weak.

[0076] The process according to the invention can be applied with a manufacturing method of the surface emitting semiconductor laser. The method of manufacturing a surface emitting semiconductor laser which included a first semiconductor mirror layer of first conductivity type over a substrate, a current confining layer over the first semiconductor mirror layer, an active region over the first semiconductor mirror layer, a second semiconductor mirror layer of second conductivity type over the active region and a contact layer including a compound semiconductor layer over the second semiconductor mirror layer, and the method includes forming a first organic layer on the contact layer, forming a second layer on the first organic layer, the second layer being resistant to a plasma ashing, forming a pattern including a first aperture in the second layer, forming a second aperture in the first organic layer by the plasma ashing of the first organic layer using a mask of the pattern including the first aperture to expose the contact layer in the

second aperture, depositing a conductive layer over a region including the contact layer exposed in the second aperture and the second layer, and forming a conductive pattern on the contact layer by a lift-off process.

[0077] According to this, damages on the surface of the contact layers is significantly prevented and an occurrence of harmful effects on the output property of the laser light is prevented.

[0078] Preferably, the manufacturing method further includes a step of forming mesa structure which extends from at least the contact layer to the current confining layer and a step of selectively oxidizing a part of the current confining layer from the sidewall of the mesa structure. The manufacturing method can be applied with the surface emitting semiconductor laser having the mesa structure.

[0079] According to another aspect of the invention, a surface emitting semiconductor laser includes a substrate, a first mirror formed over the substrate, the first mirror including semiconductor layers of first conductivity type, a second mirror formed over the substrate, the second mirror including semiconductor layers of a second conductivity type, a active region disposed between the first and second mirrors, a current confining layer disposed between the first and second mirrors, a compound semiconductor layer formed over the second mirror, and an electrode formed on the compound semiconductor layer, wherein a surface roughness of the compound semiconductor layer in at least a peripheral portion of the electrode is not more than 5 nm.

[0080] The reason why the roughness is not more than 5 nm, the surface of the compound semiconductor layers is not etched by the solution such as alkali developer. In case the aperture or opening is formed in the photoresist layer using the alkali developer described as in the prior art, the surface of the compound semiconductor layer is etched, which generally causes depths over 5 nm. Consequently, the surface emitting semiconductor laser according to the invention makes the surface roughness to be planer than that of the prior art, which prevents the degradation or aggravation of the performances and optical properties of the surface emitting semiconductor laser.

[0081] Preferably, the compound semiconductor layer includes GaAs layer of the second conductivity type. Preferably, the metal electrode is formed by the lift-off process of the photoresist layers, which are patterned on the compound semiconductor layer by the plasma ashing.

What is claimed is:

1. A method of forming a conductive pattern such as an electrode on a compound semiconductor layer comprising the steps of:

- forming a first organic layer on the compound semiconductor layer;
- forming a second layer on the first organic layer, the second layer being resistant to plasma ashing;
- forming a pattern including a first aperture in the second layer;
- forming a second aperture in the first organic layer by plasma ashing of the first organic layer using a mask pattern including the first aperture to expose the compound semiconductor layer in the second aperture; and

depositing a conductive layer over a region including the compound semiconductor layer exposed in the second aperture and the second layer;

wherein forming the pattern in the second layer includes forming the conductive pattern by a lift-off process.

2. The method as claimed in claim 1, wherein the plasma ashing comprises an oxygen radical.

3. The method as claimed in 1, wherein the first organic layer comprises a photoresist layer.

4. The method as claimed in claim 3, wherein the method further comprises a step of baking the first organic layer at a predetermined temperature.

5. The method as claimed in claim 1, wherein the second layer comprises a photoresist having silicon which is resistant to the oxygen radical.

6. The method as claimed in claim 1, wherein the second layer comprises an inorganic film.

7. The method as claimed in claim 1, wherein the second aperture of the first organic layer is processed by the plasma ashing to form an undercut to the first aperture of the second layer.

8. The method as claimed in claim 1, wherein the compound semiconductor layer comprises a compound semiconductor substrate.

9. The method as claimed in claim 1, wherein the compound semiconductor layer comprises gallium arsenide (GaAs).

10. A method of forming a conductive pattern over a compound semiconductor layer, the method comprising the steps of:

- forming a first organic layer on the compound semiconductor layer;
- forming an inorganic layer on the first organic layer;
- forming a second organic layer on the inorganic layer;
- forming a first pattern including a first aperture in the second organic layer;
- forming a second pattern including a second aperture in the inorganic layer by etching the inorganic layer using a mask of the first pattern including the first aperture;
- forming a third aperture in the first organic layer by plasma ashing of the first organic layer using a mask of the second pattern including the second aperture to expose the compound semiconductor layer in the third aperture;

depositing a conductive film over a region including the compound semiconductor layer exposed in the third aperture and the second organic layer; and

forming the conductive pattern on the compound semiconductor layer by a lift-off process.

11. The method as claimed in claim 10, wherein the first and second organic layers comprise photoresists respectively.

12. The method as claimed in claim 10, wherein the inorganic layer comprises indium-tin-oxide (ITO) or silicon oxide (SiO).

13. The method as claimed in claim 10, wherein the plasma ashing comprises an oxygen radical.

14. The method as claimed in claim 10, wherein the third aperture of the first organic layer is formed in a shape of an undercut to the second aperture of the inorganic layer.

15. A method of manufacturing a surface emitting semiconductor laser, the surface emitting semiconductor laser including a first semiconductor mirror layer of first conductivity type over a substrate, a current confining layer over the first semiconductor mirror layer, an active region over the first semiconductor mirror layer, a second semiconductor mirror layer of second conductivity type over the active region and a contact layer including a compound semiconductor layer over the second semiconductor mirror layer, the method comprising the steps of:

- forming a first organic layer on the contact layer;
- forming a second layer on the first organic layer, the second layer being resistant to a plasma ashing;
- forming a pattern including a first aperture in the second layer;
- forming a second aperture in the first organic layer by the plasma ashing of the first organic layer using a mask of the pattern including the first aperture to expose the contact layer in the second aperture;

depositing a conductive layer over a region including the contact layer exposed in the second aperture and the second layer; and

forming a conductive pattern on the contact layer by a lift-off process.

16. The method as claimed in claim 15, wherein a mesa structure which is extended from at least the contact layer to the current confining layer is formed, and wherein a part of region of the current confining layer is selectively oxidized from a sidewall of the mesa structure.

17. The method as claimed in claim 15, wherein the conductive pattern is an electrode which is connected with the contact layer in ohmic.

18. The method as claimed in claim 15, wherein the conductive pattern is formed in a ring shape and wherein an inner diameter defines an emission window for the laser light.

* * * * *