



US 20060114276A1

(19) **United States**

(12) **Patent Application Publication**
Ohashi

(10) **Pub. No.: US 2006/0114276 A1**

(43) **Pub. Date: Jun. 1, 2006**

(54) **INK JET RECORDING HEAD, LIQUID STORAGE CONTAINER AND INK JET RECORDING APPARATUS**

Publication Classification

(75) Inventor: **Tetsuya Ohashi**, Matsudo-shi (JP)

(51) **Int. Cl.**
B41J 29/38 (2006.01)

(52) **U.S. Cl.** **347/5; 347/39**

Correspondence Address:

Canon U.S.A. Inc.,
Intellectual Property Department
15975 Alton Parkway
Irvine, CA 92618-3731 (US)

(57) **ABSTRACT**

(73) Assignee: **Canon Kabushiki Kaisha**, Ohta-ku (JP)

An ink jet recording head is detachably attached to an ink jet recording apparatus including a carriage operable to reciprocally move and an optical encoder scale. An ink jet recording head, a liquid storage container, or an ink jet recording apparatus includes at least one of a light emitting element configured to emit light to an encoder scale and a light receiving element configured to receive light through the encoder scale.

(21) Appl. No.: **11/286,782**

(22) Filed: **Nov. 23, 2005**

(30) **Foreign Application Priority Data**

Nov. 26, 2004 (JP) 2004-342248

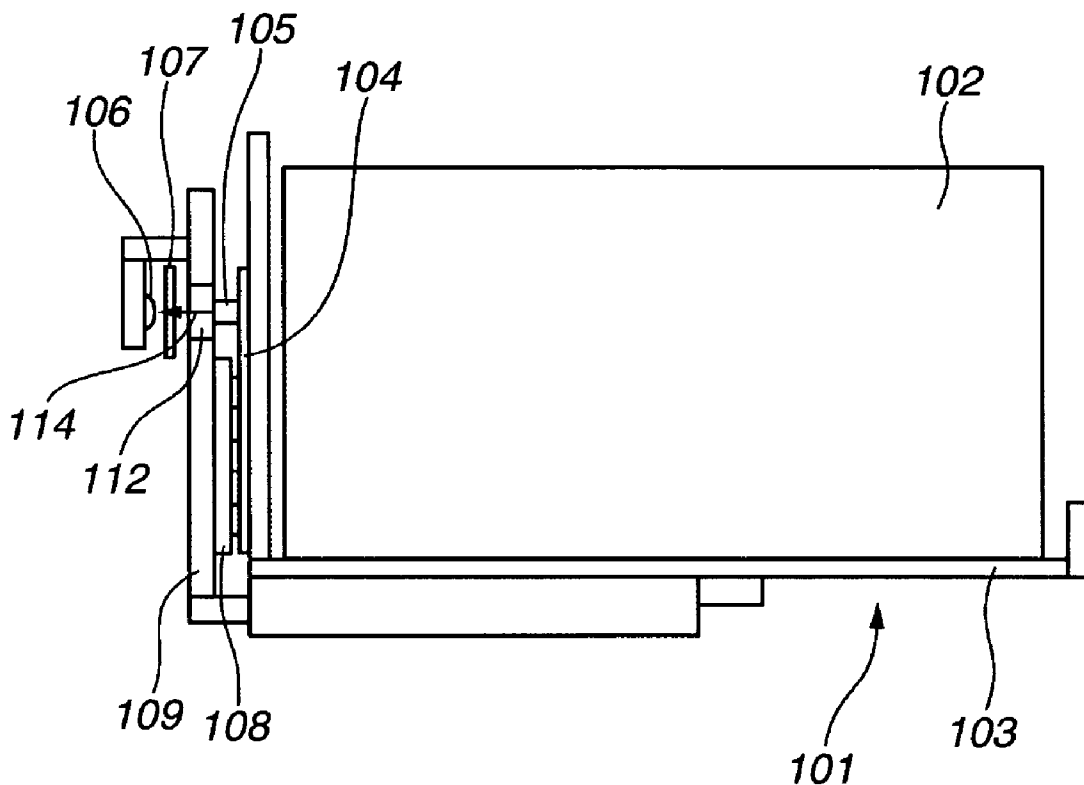

FIG.1

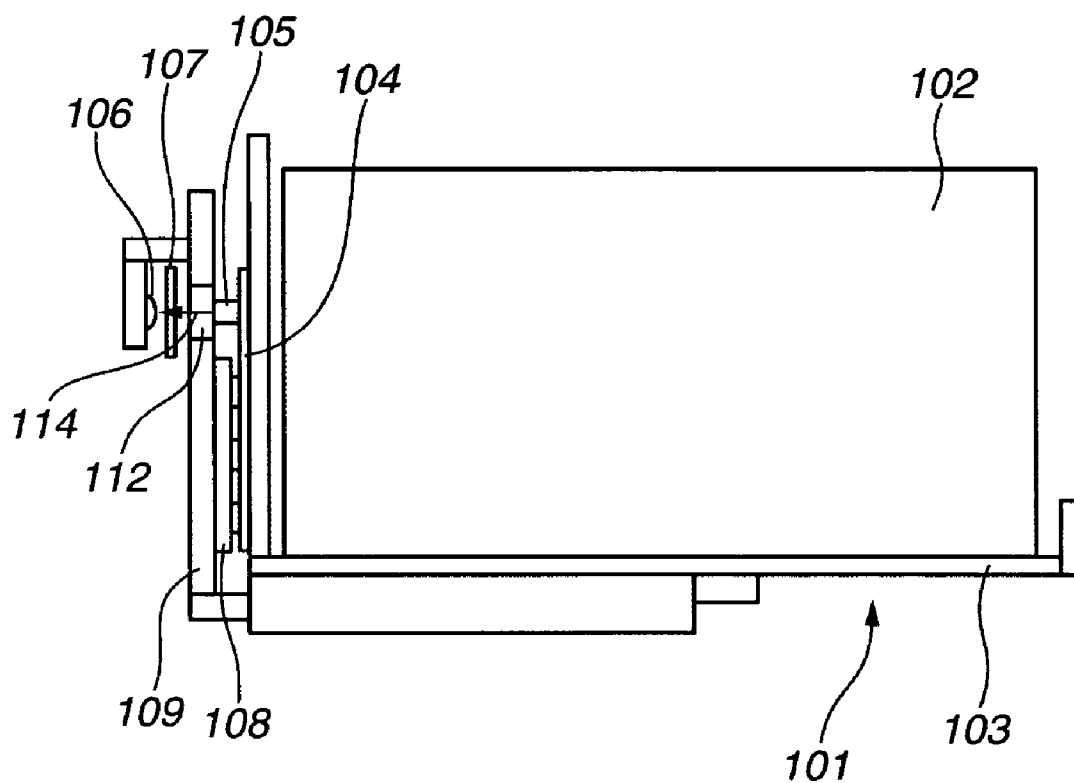

FIG.2

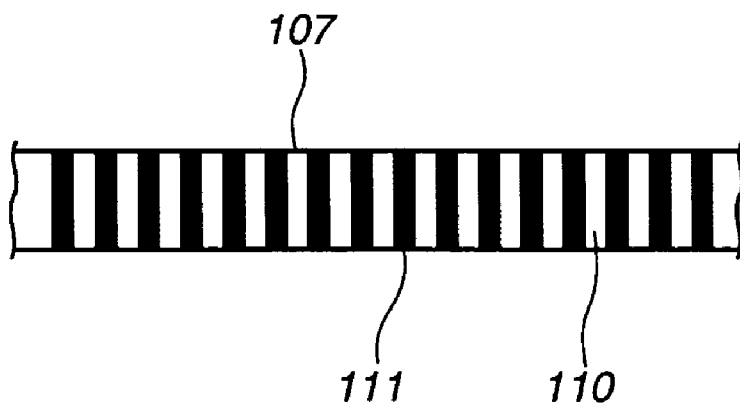

FIG.3

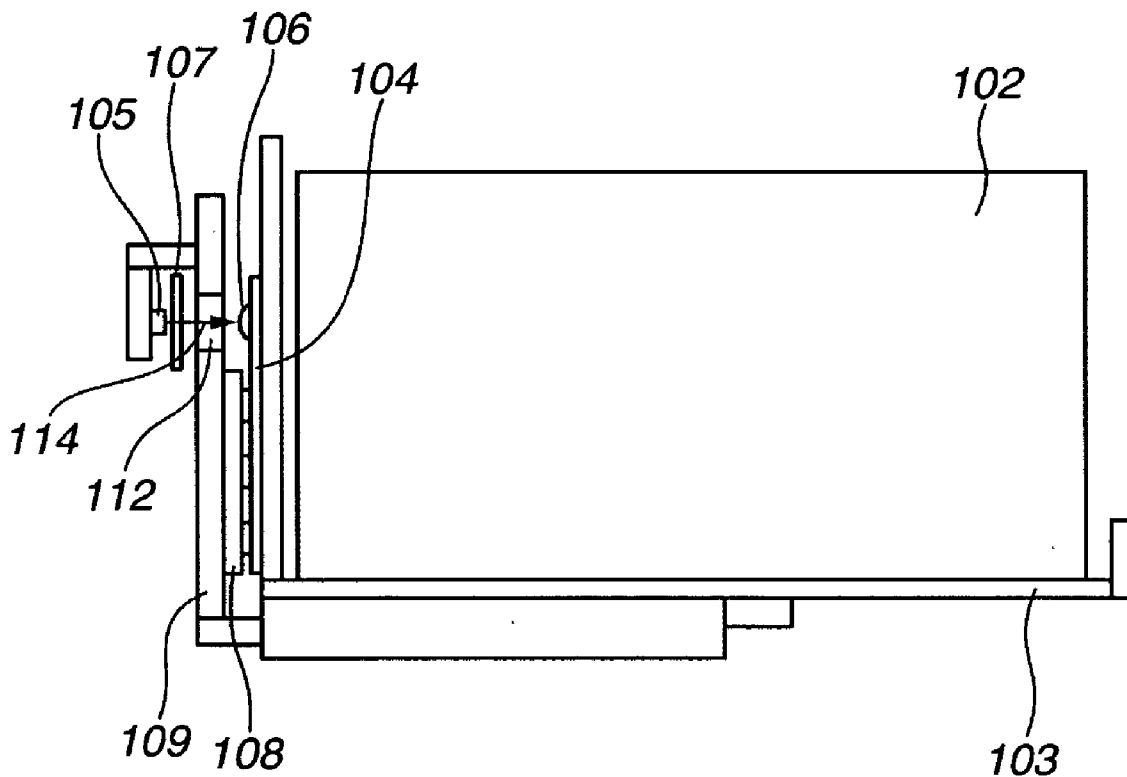

FIG. 4

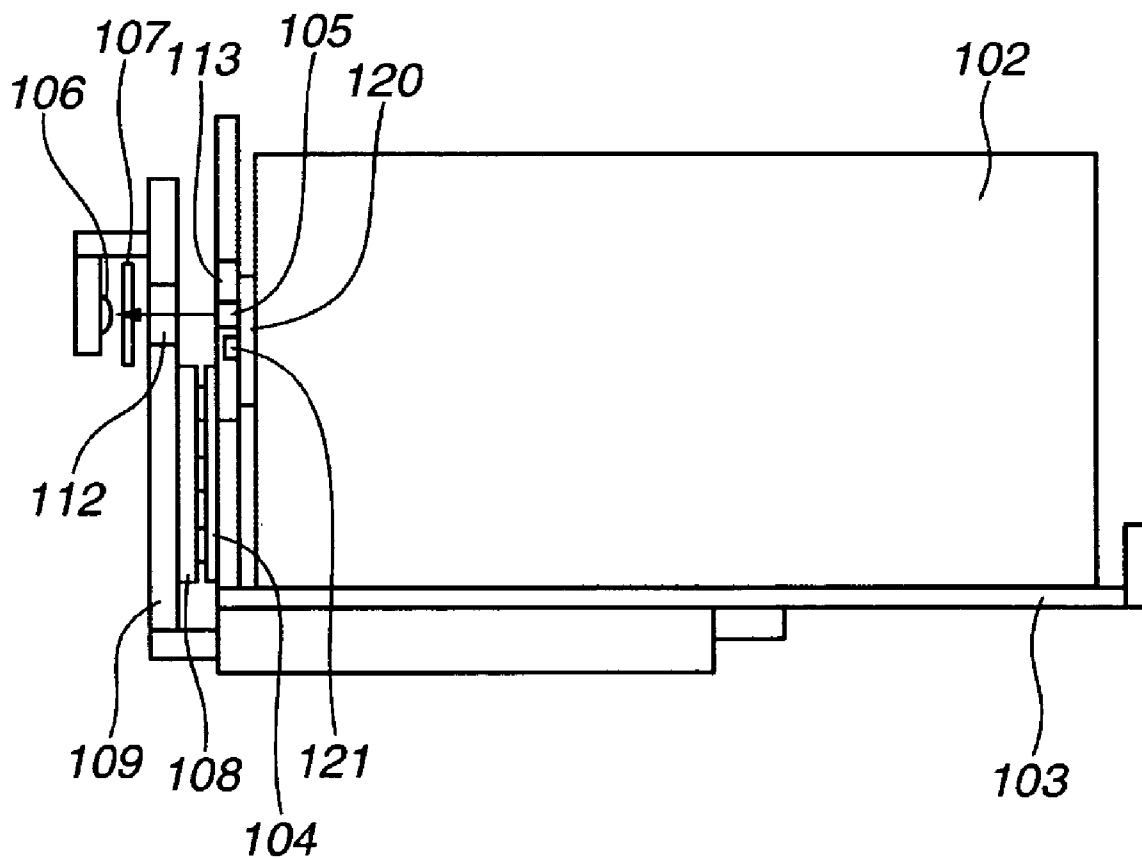

FIG. 5

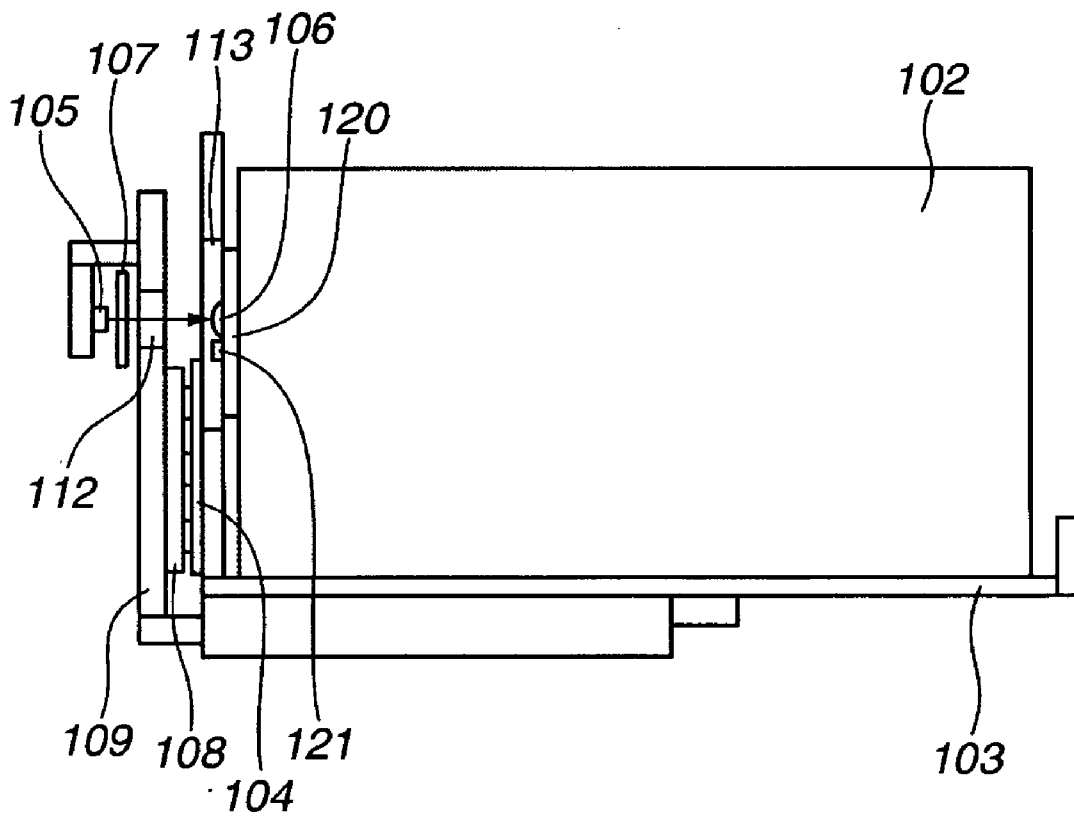

FIG. 6

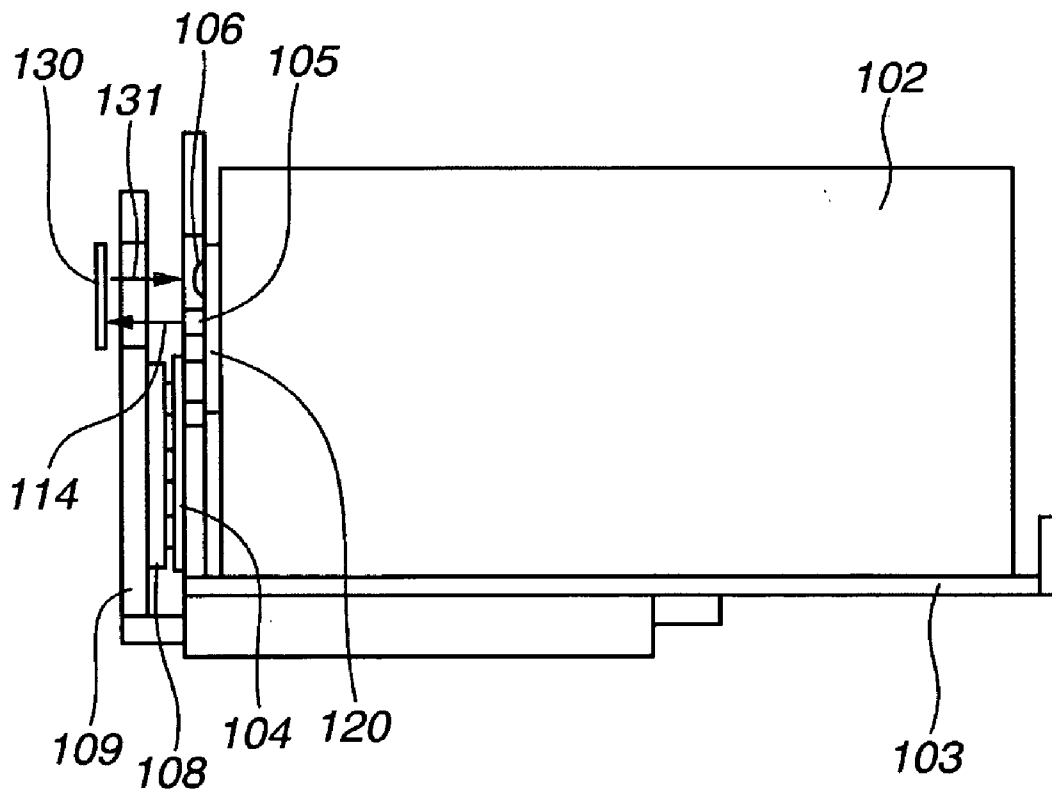

FIG. 7

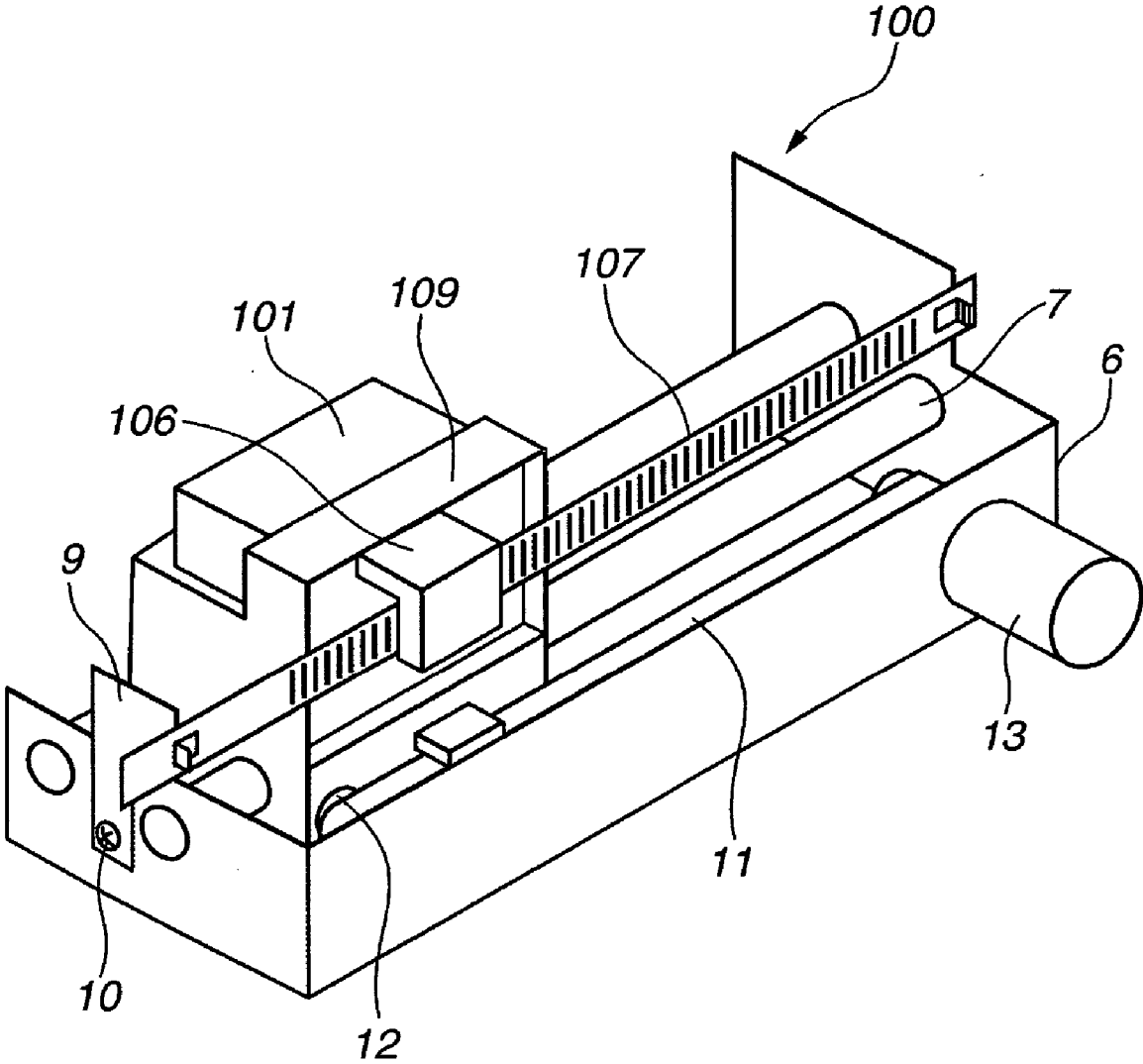
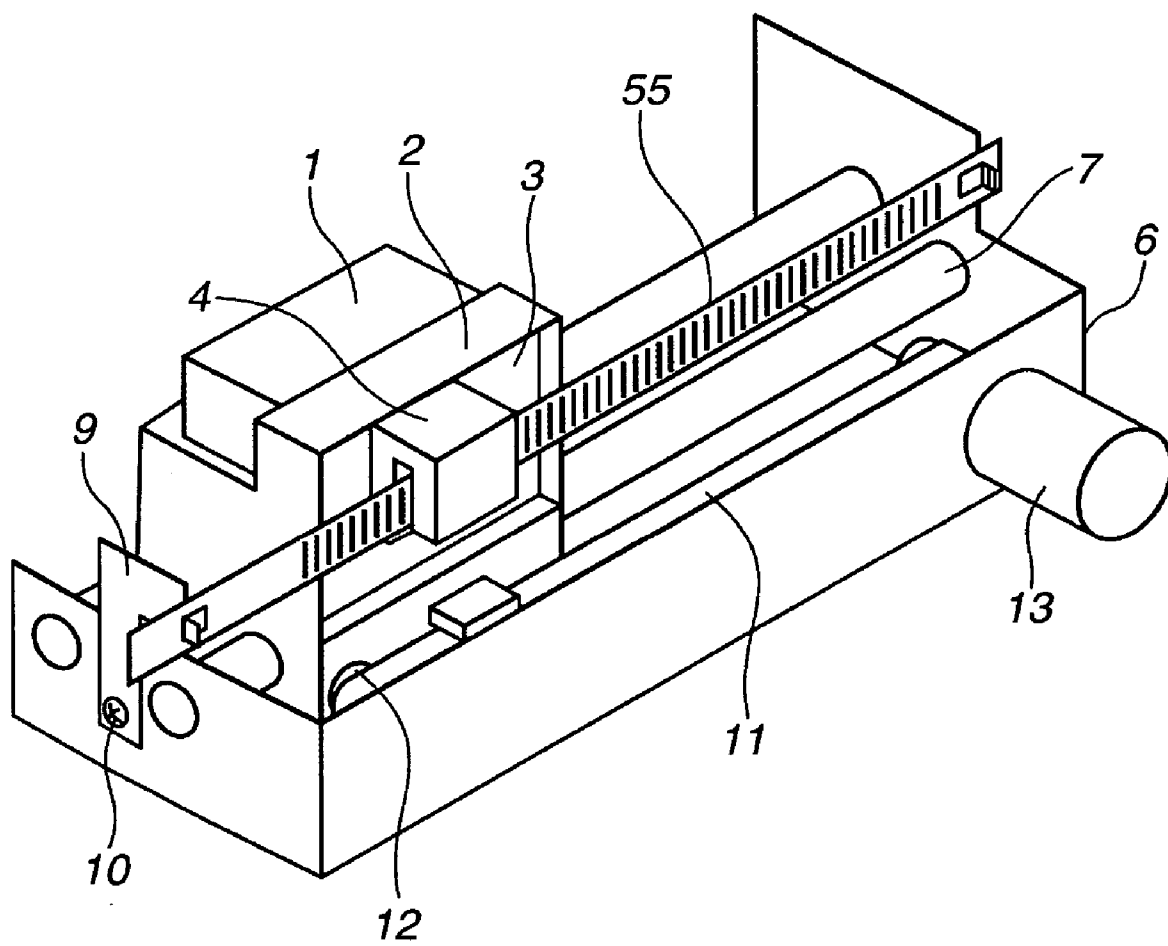

FIG. 8 PRIOR ART



**INK JET RECORDING HEAD, LIQUID STORAGE
CONTAINER AND INK JET RECORDING
APPARATUS**

BACKGROUND OF THE INVENTION

[0001] 1. Field of the Invention

[0002] The present invention relates to an ink jet recording head, a liquid storage container for containing liquid, and an ink jet recording apparatus, which discharges a liquid on a recording medium such as paper, or cloth.

[0003] 2. Description of the Related Art

[0004] In general, a serial scan type ink jet recording apparatus performs recording by discharging ink on a recording medium from a recording unit, i.e. an ink jet recording head.

[0005] The ink jet recording apparatus has advantages in that the recording unit can be easily made compact, a high-definition image can be recorded at high speed, and the like.

[0006] In such recording apparatus, ink must be discharged in a timing that a desired image is formed on the recording medium according to the moving position of a carriage. Therefore, the ink jet recording apparatus is generally provided with a linear encoder to detect the position of the carriage.

[0007] The linear encoder is stretched across in a moving direction of the carriage, and includes an encoder scale, which is a reference to detect a moving distance of the carriage, and a sensor attached to the carriage which detects a moving distance of the carriage.

[0008] **FIG. 8** is a perspective view showing the configuration of a conventional recording apparatus.

[0009] The conventional recording apparatus includes a recording head **1**, a carriage **2**, a carriage board **3**, a linear encoder sensor **4**, and a linear encoder scale **55**.

[0010] Further, the conventional recording apparatus includes a main body chassis **6**, two guide shafts **7**, a leaf spring **9**, a screw **10**, a timing belt **11**, an idle pulley **12**, and a driving motor **13**.

[0011] The main body chassis **6** is a casing for the recording apparatus, and the two guide shafts **7**, the idle pulley **12**, and the driving motor **13** are mounted on the main body chassis **6**, respectively.

[0012] The two guide shafts **7** are disposed in parallel with each other, and the idle pulley **12** and the driving motor **13** are disposed on the same side of the main body chassis **6**.

[0013] Between the idle pulley **12** and a pulley (not shown) provided to the driving motor **13**, a piece of the timing belt **11** is stretched across in parallel with the guide shaft **7**.

[0014] Further, the main body chassis **6** is provided with the leaf spring **9**.

[0015] The leaf spring **9** is fixed by the screw **10** to one side of the main body chassis **6** to which both ends of the two guide shafts **7** are attached.

[0016] One end of the linear encoder scale **55** is fixed to the side of the main body chassis **6**, and the other end is connected to the leaf spring **9** so as to be disposed in parallel with the guide shaft **7** while being pulled by proper tension.

[0017] The carriage **2** mounted with the recording head **1** is supported by the guide shaft **7** so as to slide along the guide shaft **7**.

[0018] A portion of the timing belt **11** is connected to the carriage **2**, and by rotation of the driving motor **13**, the carriage **2** can be moved along the guide shaft **7**.

[0019] The linear encoder sensor **4** is fixed on the carriage **2** with the carriage board **3**, and is arranged so as to nip the linear encoder scale **55**.

[0020] When the carriage **2** moves along the guide shaft **7** driven by the driving motor **13**, the linear encoder sensor **4** connected to the carriage **2** also moves along the linear encoder scale **55**.

[0021] The linear encoder sensor **4** converts positional information on the linear encoder scale **55** into a pulse signal.

[0022] The linear encoder sensor **4** transmits the pulse signal to a main board (not shown) via a flexible cable (not shown) and the like from the carriage board **3**, and to an arithmetic unit (not shown) on the main board.

[0023] The arithmetic unit controls the position and the speed of the carriage **2** based on the pulse signal.

[0024] There are various types of linear encoders, such as a magnetic type and an optical type. The linear encoder of the magnetic type has a magnetic sensor and a scale configured of a metallic shaft or a sheet material to which magnetic information is given at a constant pitch.

[0025] As the optical linear encoder, in addition to a light emitting element and a light receiving element, one type has a scale with dark and light patterns of a constant pitch. Another type has a scale with an uneven shape of a constant pitch, and so forth.

[0026] The various types of linear encoders above described have advantages and disadvantages, respectively.

[0027] The magnetic linear encoder has an advantage in that, even when there is a slight ink contamination, it does not affect the performance of the encoder.

[0028] On the other hand, there are disadvantages in that it is difficult to make the magnetic linear encoder of high resolution, and hard to widen a gap between the encoder scale and the encoder. In addition, there is a problem of accuracy in mounting, and the gap is prone to be clogged by matter.

[0029] Further, in the case of the magnetic linear encoder, caution is required in handling magnetic tools and the like.

[0030] In the optical type linear encoder, high resolution can be easily obtained, and it is easy to make the gap between the encoder scale and the encoder sensor relatively wider.

[0031] In addition, it can be easily assembled. However, there is the disadvantage in that the performance can sharply deteriorate by ink contamination.

[0032] With respect to the conventional recording apparatus which is described above, even in the case of the popular and low cost apparatus, high resolution and high accuracy have been noticeably achieved, and an apparatus has begun to appear which shoots ink at a pitch of 1200 dots per 25.4 mm (one inch).

[0033] In the case where ink is shot at such intervals, needless to say, an ink shooting speed is required to increase, and moreover, high resolution is required of the linear encoder.

[0034] Naturally, it is ideal to use a linear encoder having a resolution of 1200 or more dots per 25.4 mm for a printer having 1200 dots per 25.4 mm.

[0035] However, because of a limit to the cost and the size, a linear encoder has been often used in which 300 dots or 600 dots per 25.4 mm are multiplied.

[0036] In recent years, a linear encoder having 1200 dots per 25.4 mm can be made at a low cost, and such a type that can be used for the general printer has begun to appear.

[0037] However, the influence arising from a shift of the phase and the amplitude of the output signal of the sensor which is generated by the contamination of the parts by ink and the like has become apparent as the preciseness of the linear encoder is increased, and is not negligible.

[0038] U.S. Pat. No. 6,264,303 discloses a cleaning member which slides against the linear scale of the optical encoder and removes a surface contamination.

[0039] Japanese Patent Application Laid-Open No. 2000-141802 discloses a method in which the cleaning member abuts against and separates from the linear scale.

[0040] Japanese Patent Application Laid-Open No. 2001-121721 discloses a cleaning timing and the situation under which the cleaning is performed.

[0041] However, in the case of the optical linear encoder where a ray to be sensed is required to be focused at the sensor side in order to detect a position, the contamination of the sensor has much larger effect than the contamination of the scale.

[0042] Further, associated with high resolution of the linear encoder, the ink droplet to be used has become small, and as a result, minute ink (hereinafter referred to as ink mist) is generated that cannot shoot on the recording medium.

[0043] Since this ink mist is extremely minute, it is prone to soar to the position of the linear encoder associated with the movement of the carriage. Accordingly, there is a great possibility that the mist enters into the sensor of the linear encoder.

[0044] Thus, it has become evident that the sensor of the linear encoder is often contaminated earlier than the scale of the linear encoder.

[0045] As described above, in the conventional apparatus, even when the cleaning of the encoder itself is performed, if the ink mist adheres to the detection sensor, durability of the linear encoder deteriorates.

[0046] There have been also problems such as disarray of print images and shutdown of the apparatus due to a reading error.

[0047] With respect of the contamination of the encoder scale, the replacement thereof by periodic servicing or the cleaning of the surface by the user himself can be easily performed.

[0048] However, with respect to the contamination of the detection sensor of the linear encoder, since a light emitting unit and a light receiving unit are integrally configured, it is extremely difficult to perform the cleaning.

[0049] Further, since these units are configured integrally with the recording apparatus, it is not possible to replace the sensor of the linear encoder unless the recording apparatus is dismantled and taken out.

[0050] In the case where a replacement need arises, the user is forced to put up with an extreme inconvenience of sending the main body to the customer service department to replace the parts thereof.

SUMMARY OF THE INVENTION

[0051] The present invention has been made in view of the above described problems.

[0052] The present invention is directed to a liquid storage container, an ink jet recording head, and an ink jet recording apparatus, which can reduce a reading error of a light transmission type linear encoder due to mist contamination without performing any particular operation.

[0053] In one aspect of the present invention, an ink jet recording head detachably attached to an ink jet recording apparatus having a carriage that makes a reciprocal motion along the recording medium and an optical encoder scale, includes at least one of a light emitting unit configured to emit light to the encoder scale and a light receiving unit configured to receive light through the encoder scale.

[0054] Further, in one embodiment of the present invention, the ink jet recording head has the light emitting unit. Further, the ink jet recording head has integrally an ink storage unit adapted to contain ink.

[0055] In another aspect of the present invention, a liquid storage container detachably attached to an ink jet recording apparatus includes a carriage configured to reciprocally move along a recorded medium and an optical encoder scale has at least one of a light emitting unit configured to emit light to the encoder scale and a light receiving unit configured to receive light through the encoder scale.

[0056] Further, in one embodiment, the liquid storage container includes the light emitting unit as its feature.

[0057] Further, the liquid storage container has a board that includes the light emitting unit and an information recording element configured to hold information relating to the liquid storage container.

[0058] In a further aspect of the present invention, an ink jet recording apparatus includes a carriage configured to reciprocally move along a recording medium, an optical encoder scale, an ink jet recording head having a light emitting unit configured to emit light to the encoder scale, and the carriage having a light receiving unit configured to receive light from the light emitting unit through the encoder scale.

[0059] In the present invention, at least one of the light emitting unit (light emitting diode (LED)) of the linear encoder for performing the position detection of the carriage of the recording apparatus and the light receiving sensor is provided in the ink jet recording head or the liquid storage container detachably attached to the recording apparatus.

[0060] In these configurations, the light emitting unit and the light receiving unit can be periodically exchanged together with the detachable and attachable component parts before the adhesive contamination of the mist and the like arisen from printing is piled up.

[0061] Consequently, the occurrence of the malfunction and the print failure of the recording apparatus can be reduced.

[0062] Further, since the light emitting unit and the light receiving sensor can be configured to be detachably attached to the recording apparatus, the contamination of the light emitting unit and the light receiving sensor can be easily removed without a heavy operation.

[0063] Further features of the present invention will become apparent from the following detailed description of exemplary embodiments with reference to the attached drawings.

BRIEF DESCRIPTION OF THE DRAWINGS

[0064] The accompanying drawings, which are incorporated in and constitute a part of the specification, illustrate embodiments of the invention and, together with the description, serve to explain the principles of the invention.

[0065] FIG. 1 is a schematic cross sectional view of an ink jet recording head unit according to a first embodiment of the present invention.

[0066] FIG. 2 is an explanatory view of an encoder scale.

[0067] FIG. 3 is a cross sectional view in which the arrangement of a light emitting diode (LED) and a light receiving sensor is reversed in the ink jet recording head unit according to the first embodiment of the present invention.

[0068] FIG. 4 is a schematic cross sectional view of an ink jet recording head unit according to a second embodiment of the present invention.

[0069] FIG. 5 is a cross sectional view in which the arrangement of a light emitting diode (LED) and a light receiving sensor is reversed in the ink jet recording head unit according to a second embodiment of the present invention.

[0070] FIG. 6 is a schematic cross sectional view of an ink jet recording head unit according to a third embodiment of the present invention.

[0071] FIG. 7 is a perspective view of the ink jet recording apparatus according to the first embodiment of the present invention.

[0072] FIG. 8 is a perspective view of a conventional ink jet recording apparatus.

DETAILED DESCRIPTION OF THE EMBODIMENTS

[0073] Embodiments of the invention will be described in detail below with reference to the drawings.

First Embodiment

[0074] FIG. 7 is a perspective view of an ink jet recording apparatus 100 according to a first embodiment of the present invention.

[0075] In FIG. 7, reference numeral 101 denotes a recording head that constitutes a recording unit, which is configured to be detachably attached to the ink jet recording apparatus 100.

[0076] FIG. 1 is a schematic cross sectional view showing a cross section in the ink jet recording head unit in the first embodiment.

[0077] Reference numeral 102 denotes an ink tank, and reference numeral 103 denotes a holder unit that holds the ink tank 102.

[0078] The first embodiment will describe a configuration having the ink tank 102 detachably attached to the holder unit 103.

[0079] The holder unit 103 is configured to be integrated with the recording head chip, and a tank containing ink is detachably attached.

[0080] The recording head may be of a disposable type in which a chip unit that performs discharging and an ink tank are integrally configured and cannot be separated.

[0081] Reference numeral 104 denotes an electric board that transmits an electric signal such as a driving signal associated with ink discharging in the ink jet recording apparatus main body and the recording head 101.

[0082] Reference numeral 109 denotes a printer carriage as a transport unit to be mounted with the recording head 101, and the recording head 101 scans the recording medium by the printer carriage 109.

[0083] Reference numeral 108 denotes a connector board provided in the printer carriage 109, and having an electric connecting point to perform an electric connection between the recording head 101 and the recording apparatus 100.

[0084] Reference numeral 107 is an optical encoder scale that shows positional information in a scanning direction, and uses a scale having a light shielding portion printed on a transparent polyester film.

[0085] The encoder scale 107, as another configuration, may use a multi-layer metallic thin plate and the like, such as Ni—Cu—Ni, provided with a light transmission slit.

[0086] Reference numeral 106 denotes a light receiving sensor as a position detection unit to read the encoder scale 107 and detect positional information, in which a photo transistor is arranged. The light receiving sensor 106 is electrically connected to the control unit (not shown) of the recording apparatus 100 through an FPC (flexible print cable) and the carriage board (both not shown).

[0087] Reference numeral 105 denotes a light emitting diode (LED) 105, which emits light that passes through the encoder scale 107 toward the light receiving sensor 106.

[0088] The light receiving sensor 106 is fixed to the printer carriage 109, and the LED 105 is fixed to the recording head 101 opposed to the light receiving sensor 106 where the photo transistor is arranged.

[0089] Reference numeral 112 is an opening provided in the printer carriage 109 to guide a luminous light 114 of the LED 105 to the light receiving sensor 105.

[0090] In the first embodiment, the LED 105 is mounted on the electric board 104 provided in the recording head 101,

and an electric connection between the ink jet recording apparatus **100** and the LED **105** is made by wiring in the electric board **104**.

[0091] The position of the LED **105** is not limited to this configuration. If the LED is positioned opposing the light receiving sensor **106** provided in the recording apparatus **100**, it is possible to dispose the LED at any position on the recording head **101** by electric wiring.

[0092] Further, by guiding the light with the light guide member, flexibility in arranging the LED **105** can be enhanced.

[0093] The led **105** receives the supply of a driving voltage necessary for emission by the above described electric connection and performs the emission.

[0094] Although it is possible to allow the emission always with the recording apparatus **100** at power-on when the recording head **101** is mounted on the carriage **109**, according to the present embodiment, the emission control is performed only when the position detection is required by the recording apparatus **100**.

[0095] In this manner, it is possible to reduce power consumption at print waiting time and the like.

[0096] Since the recording head **101** is fixed to the printer carriage **109**, the light emitting LED **105** provided in the recording head **101** makes a reciprocal motion along the encoder scale **107** together with the scanning of the printer carriage **109**.

[0097] Following this reciprocal motion, the light receiving sensor **106** reads the positional information located on the encoder scale **107**, and outputs a position detection signal.

[0098] Next, the encoder scale **107** will be described using FIG. 2.

[0099] In FIG. 2, marks **110** and **111** show the positional information on the encoder scale **107**.

[0100] For example, the mark **110** is taken as an optical transmission portion, and the mark **111** as an optical reflecting portion (or non-transmission portion).

[0101] The light emitted by the LED **105** transmits the transmission portion **110**, and is received by the light receiving sensor **106**.

[0102] The light emitted by the LED **105** is blocked at the reflecting portion **111**, and is not received by the light receiving unit sensor **106**.

[0103] In such configuration, the output of the light receiving sensor **106** creates mutually opposite results at the transmission portion **110** and the reflecting portion **111**.

[0104] The output from the light receiving sensor **106** is a pulse signal, and by counting this pulse signal, it is possible to detect the position of the printer carriage **109**.

[0105] As described above, by providing the LED **105** in the recording head **101**, at least one time replacement of the recording head **101** is performed with in the life time of the ink jet recording apparatus **100**.

[0106] Hence, it is possible to reduce piling of the contamination on the surface of the LED **105** by ink mist arisen at the printing time and other suspended matters inside the apparatus.

[0107] It is possible to prevent drop of the light emission amount of the LED **105** due to the contamination and malfunction of the recording apparatus **100** due to position detection errors of the printer carriage **109**.

[0108] Further, since the LED **105** is arranged on the exchangeable recording head **101**, it is not always necessary to provide a cover to prevent mist adhesion.

[0109] By detaching the recording head **101**, it is possible to easily clean the LED **105**.

[0110] The contamination by the ink mist and other suspended matters inside the apparatus and the like occurs also on the light receiving sensor **106** and the encoder scale **107** in addition to the LED **105**.

[0111] According to an experiment conducted with the configuration according to the first embodiment, by resetting the contamination of at least one of the LED **105** and the light receiving sensor **106**, the position detection failure of the printer carriage **109** has not occurred within the life of the recording apparatus **100**.

[0112] FIG. 3 shows the arrangement of the LED **105** and the light receiving sensor **106** that reverses the configuration shown in FIG. 1.

[0113] In the present configuration, the output signal of the light receiving sensor **106** is outputted to the recording apparatus **100** through the electric board **104** and the connector board **108**.

[0114] Also in the configuration of FIG. 3, it is possible to reduce the position detection failure of the printer carriage **109** within the life of the recording apparatus **100** by making the light receiving sensor **106** exchangeable.

Second Embodiment

[0115] Next, a second embodiment of the present invention will be described using FIG. 4. The second embodiment changes a position of the LED **105** in the configuration according to the first embodiment. The same component parts as the first embodiment will be identified with the same reference numerals, and the description thereof will be omitted.

[0116] In the schematic cross sectional view of FIG. 4, reference numeral **120** denotes an electric board fixed to an ink tank **102** that includes an electric contact point connected to the electric board **104**.

[0117] By mounting the ink tank **102** on the recording head, the LED **105** is configured in the ink tank **102** to correspond to a position opposed to the light receiving sensor **106** provided in the recording apparatus **100**.

[0118] Further, the LED **105** can emit light only when the ink tank **102** is accurately mounted, and electrical connection between the electric board **104** and the electric board **120** is correctly performed.

[0119] Reference numeral **113** denotes an opening provided in the holder unit **103** to guide light of the LED **105** to the light receiving sensor **106**.

[0120] In the second embodiment, the LED **105** is mounted on the electric board **120** provided in the ink tank **102**.

[0121] Further, on the electric board **120**, a storage element **121** that stores information relating to the ink tank **102** is mounted.

[0122] In this case, based on the information in the storage element **121**, control of the LED **105** such as light emission amount adjustment and the like can be performed by the recording apparatus **100**.

[0123] Further, together with confirmation of the electric connection between the electric board **104** and the electric board **120**, the information in the storage element **121** may be confirmed by the recording apparatus **100**. Thus, the recording apparatus **100** can recognize the case in which the ink tank **102** is erroneously mounted.

[0124] When the ink tank **102** is erroneously mounted, the recording apparatus **100** shuts down the operation or the like, thereby notifying the user of the erroneous mounting of the ink tank **102**, so that print errors can be prevented in advance.

[0125] The driving power can be supplied from the storage element driving power by wiring within the control board.

[0126] The electric connection between the electric board **120** and the recording apparatus **100** is performed through the electric board **104** provided in the recording head **101**. However, in the case where the electric contact point can be disposed on the recording apparatus **100**, the electric board **120** and the recording apparatus **100** may be directly connected.

[0127] In the case where the mounting of the LED **105** on the electric board **120** is difficult due to the limitation imposed on the electric connection position, the electric contact point is constituted by an electric flexible cable.

[0128] By wiring of the electric flexible cable, it is possible to enhance the flexibility of the LED **105** position on the ink tank **102**.

[0129] According to the present configuration, by providing the LED **105** in the ink tank **102** which is exchanged when the ink is consumed, it is possible to exchange the LED **105** in the quantitative printing in the recording apparatus **100**.

[0130] Consequently, occurrence of the malfunction of the recording apparatus **100**, which results from the contamination by ink mist, can be reliably prevented.

[0131] FIG. 5 shows a configuration according to the second embodiment in which the arrangement of the LED **105** and the light receiving sensor **106** is reversed, as similar to the first embodiment.

[0132] With the above configuration, the same effect as described in the first embodiment can be obtained.

Third Embodiment

[0133] Next, a third embodiment of the present invention will be described in reference to FIG. 6.

[0134] The third embodiment changes the configuration with respect to positions of the LED **105** and the light receiving sensor **106** described in the first and second embodiments.

[0135] The same component parts as the first and second embodiments are identified with the same reference numerals and the description thereof will be omitted.

[0136] In the schematic cross sectional view of FIG. 6 that shows a portion of the cross section of an ink jet recording apparatus, reference numeral **130** denotes an encoder scale, which is a reflecting type scale having portions alternately showing high reflectance and low reflectance on a continuous film.

[0137] In the present configuration, the reflecting type encoder scale **130** is used, and both the LED **105** and the light receiving sensor **106** are provided on the ink tank **102**. Though, according to the third embodiment, the LED **105** and the light receiving sensor **106** are provided on the ink tank **102**, it is possible to provide them on the recording head **101**.

[0138] A reflecting plate made of metalized resin film is used in the encoder scale **130**.

[0139] A reflecting portion and a non reflecting portion are provided on this reflecting plate at predetermined pitches, and cord shaped patterns provided at uniform intervals are detected by the light receiving sensor **106** using difference of the reflectance.

[0140] By outputting the output value of the light receiving sensor **106** to the control unit (not shown) of the recording apparatus **100**, the positional information of the carriage **109** is detected.

[0141] Thus, even in the case where the reflecting type encoder scale is used, the present invention is applicable.

[0142] While each of the above embodiments has described the optical linear encoder, the present invention is not limited to this, and for example, the invention is also adaptable to an optical rotary encoder.

[0143] While the present invention has been described with reference to exemplary embodiments, it is to be understood that the invention is not limited to the disclosed exemplary embodiments. The scope of the following claims is to be accorded the broadest interpretation so as to encompass all modifications, equivalent structures and functions.

[0144] This application claims priority from Japanese Patent Application No. 2004-342248 filed Nov. 26, 2004, which is hereby incorporated by reference herein in its entirety.

What is claimed is:

1. An ink jet recording head detachably attached to an ink jet recording apparatus including a carriage operable to reciprocally move along a recording medium, and an optical encoder scale, the ink jet recording head comprising:

at least one of a light emitting unit configured to emit light to the encoder scale, and a light receiving unit configured to receive light through the encoder scale.

2. The ink jet recording head according to claim 1, further comprising the light emitting unit.

3. The ink jet recording head according to claim 1, further comprising an integrated ink storage unit adapted to contain ink.

4. A liquid storage container detachably attached to an ink jet recording apparatus including a carriage operable to reciprocally move along a recording medium, and an optical encoder scale, the liquid storage container comprising:

at least one of a light emitting unit configured to emit light to the encoder scale, and a light receiving unit configured to receive light through the encoder scale.

5. The liquid storage container according to claim 4, further comprising the light emitting unit.

6. The liquid storage container according to claim 5, further comprising a board including the light emitting unit and an information storage element configured to hold information relating to the liquid storage container.

7. An ink jet recording apparatus, comprising:

a carriage configured to reciprocally move along a recording medium;

an optical encoder scale;

an ink jet recording head having a light emitting unit configured to emit light to the encoder scale; and

a carriage having a light receiving unit configured to receive light from the light emitting unit through the encoder scale.

* * * * *