



(12) **EUROPEAN PATENT APPLICATION**

(88) Date of publication A3:
21.08.2013 Bulletin 2013/34

(51) Int Cl.:
B81C 1/00 (2006.01) **B01L 3/00** (2006.01)
B01J 19/00 (2006.01)

(43) Date of publication A2:
01.10.2008 Bulletin 2008/40

(21) Application number: **08006052.8**

(22) Date of filing: **28.03.2008**

(84) Designated Contracting States:
AT BE BG CH CY CZ DE DK EE ES FI FR GB GR HR HU IE IS IT LI LT LU LV MC MT NL NO PL PT RO SE SI SK TR
Designated Extension States:
AL BA MK RS

(72) Inventors:
• **Fujiwara, Takayuki**
Minami-Ashigara-shi,
Kanagawa (JP)
• **Miyoshi, Yoshiyuki**
Minami-Ashigara-shi,
Kanagawa (JP)

(30) Priority: **29.03.2007 JP 2007089631**

(74) Representative: **HOFFMANN EITL**
Patent- und Rechtsanwälte
Arabellastrasse 4
81925 München (DE)

(71) Applicant: **FUJIFILM Corporation**
Minato-ku
Tokyo 106-8620 (JP)

(54) **Microchemical chip and method for fabricating the same**

(57) A microchemical chip (10) having at least one micro channel (12) through which a hydrophilic fluid flows, comprises: a base plate (14) having a hydrophilic part which forms the micro channel on the surface of the plate; a top plate (16) disposed opposite and parallel to the base plate on the side of the micro channel of the base plate; and a channel height adjusting device (18) which adjusts a distance between the base plate and the top plate to adjust a channel height (H) of the micro channel.

FIG.2

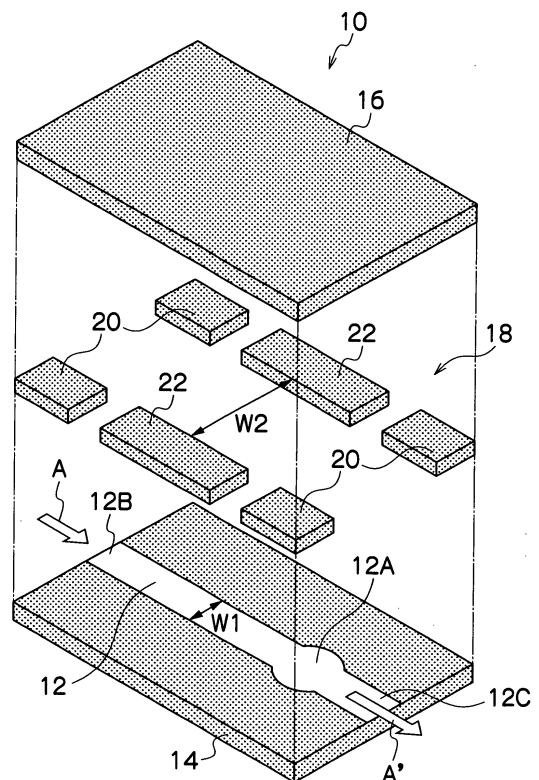



EUROPEAN SEARCH REPORT

Application Number
EP 08 00 6052

DOCUMENTS CONSIDERED TO BE RELEVANT			
Category	Citation of document with indication, where appropriate, of relevant passages	Relevant to claim	CLASSIFICATION OF THE APPLICATION (IPC)
X	WO 2005/098431 A1 (EGOMEDICAL SWISS AG [CH]; STIENE MATTHIAS [DE]) 20 October 2005 (2005-10-20) * figures 5,6 * * page 10, line 8 - page 12, line 2 * * page 26, line 13 - line 22 * * page 27, line 12 - line 20 * -----	1-4,6-17	INV. B81C1/00 B01L3/00 B01J19/00
X	WO 99/29497 A1 (CALIPER TECHN CORP [US]) 17 June 1999 (1999-06-17) * figures 2C, 4 * * page 26, line 13 - line 31 * -----	1-6, 10-14, 16-19	
X	JP 2000 025222 A (BROTHER IND LTD) 25 January 2000 (2000-01-25) * paragraph [0026] - paragraph [0033] * * paragraph [0041] * * figure 5 * -----	1-4,17, 18	
X	JP 2006 087974 A (NTT ADVANCED TECH KK) 6 April 2006 (2006-04-06) * figures 5, 9 * * paragraphs [0018], [0021], [0024] * -----	1-4, 10-14,17	TECHNICAL FIELDS SEARCHED (IPC) B81C B81B B01J B01L
The present search report has been drawn up for all claims			
Place of search Berlin		Date of completion of the search 11 July 2013	Examiner Meister, Martin
CATEGORY OF CITED DOCUMENTS X : particularly relevant if taken alone Y : particularly relevant if combined with another document of the same category A : technological background O : non-written disclosure P : intermediate document		T : theory or principle underlying the invention E : earlier patent document, but published on, or after the filing date D : document cited in the application L : document cited for other reasons ----- & : member of the same patent family, corresponding document	

2
EPO FORM 1503 03.82 (P/4C01)

**ANNEX TO THE EUROPEAN SEARCH REPORT
ON EUROPEAN PATENT APPLICATION NO.**

EP 08 00 6052

This annex lists the patent family members relating to the patent documents cited in the above-mentioned European search report.
The members are as contained in the European Patent Office EDP file on
The European Patent Office is in no way liable for these particulars which are merely given for the purpose of information.

11-07-2013

Patent document cited in search report	Publication date	Patent family member(s)	Publication date
WO 2005098431 A1	20-10-2005	AT 385572 T	15-02-2008
		AU 2004318179 A1	20-10-2005
		BR PI0418539 A	22-05-2007
		CA 2497244 A1	05-09-2005
		CN 1934444 A	21-03-2007
		DE 602005000010 T2	30-11-2006
		DK 1574858 T3	25-09-2006
		EG 25023 A	13-06-2011
		EP 1574858 A1	14-09-2005
		EP 1723412 A1	22-11-2006
		ES 2264118 T3	16-12-2006
		HK 1080146 A1	25-08-2006
		IL 177192 A	30-12-2010
		JP 4630089 B2	09-02-2011
		JP 2005249796 A	15-09-2005
		PT 1574858 E	31-08-2006
		RU 2376603 C2	20-12-2009
		SI 1574858 T1	31-10-2006
		US 2005196747 A1	08-09-2005
		US 2011136249 A1	09-06-2011
WO 2005098431 A1	20-10-2005		
WO 9929497 A1	17-06-1999	AU 1534799 A	28-06-1999
		EP 1039995 A1	04-10-2000
		US 6074725 A	13-06-2000
		US 6509085 B1	21-01-2003
		WO 9929497 A1	17-06-1999
JP 2000025222 A	25-01-2000	NONE	
JP 2006087974 A	06-04-2006	NONE	