



US 20040262139A1

(19) **United States**

(12) **Patent Application Publication** (10) **Pub. No.: US 2004/0262139 A1**

Ieda et al.

(43) **Pub. Date: Dec. 30, 2004**

(54) **PUSH SWITCH APPARATUS**

(30) **Foreign Application Priority Data**

(75) Inventors: **Kiyokazu Ieda**, Chiryu-shi (JP); **Eiji Mushiake**, Chita-gun (JP); **Takeshi Ito**, Chiryu-shi (JP); **Kazuyoshi Mori**, Chita-Shi (JP); **Yuichi Murakami**, Chiryu-shi (JP); **Noriyasu Onishi**, Nishikasugai-gun (JP); **Teruya Tomiyasu**, Toyota-shi (JP)

Apr. 22, 2003 (JP) 2003-117205

Apr. 22, 2003 (JP) 2003-117214

Publication Classification

(51) **Int. Cl.⁷** **H01H 35/00**

(52) **U.S. Cl.** **200/341**

(57) **ABSTRACT**

A push switch apparatus includes a switch case adapted to be a base member, a switch mounted on the switch case, a switch cap made of an elastic material and supported on the switch case for covering the switch, a switch button supported by the base member and having an actuating portion for pushing the switch and an switch plate mounted on the switch case and arranged between the switch cap and the switch button. The switch plate having a contact surface contacts the switch button when the actuating portion of the switch button pushes the switch.

Correspondence Address:

BURNS DOANE SWECKER & MATHIS L L P
POST OFFICE BOX 1404
ALEXANDRIA, VA 22313-1404 (US)

(73) Assignee: **AISIN SEIKI KABUSHIKI KAISHA**, Kariya-shi (JP)

(21) Appl. No.: **10/827,345**

(22) Filed: **Apr. 20, 2004**

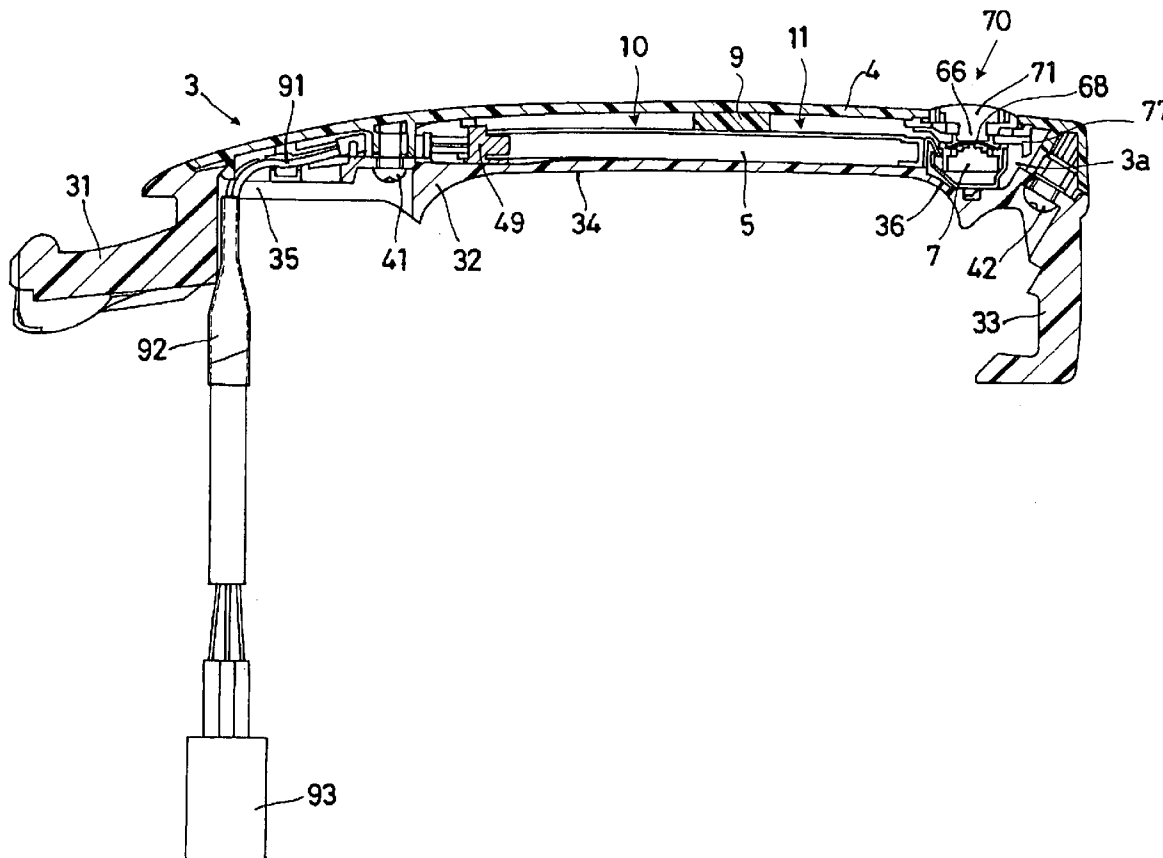

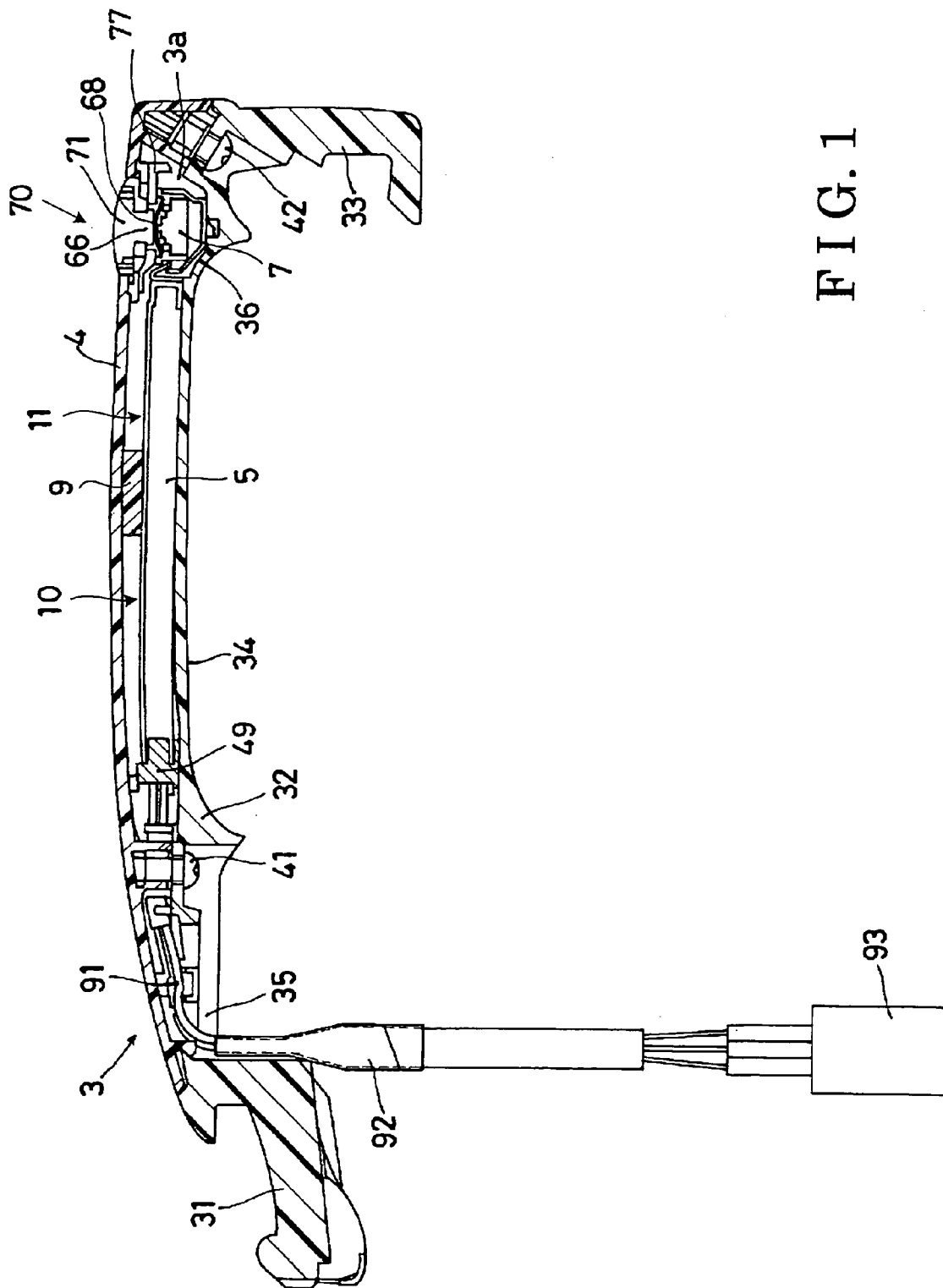

FIG. 2

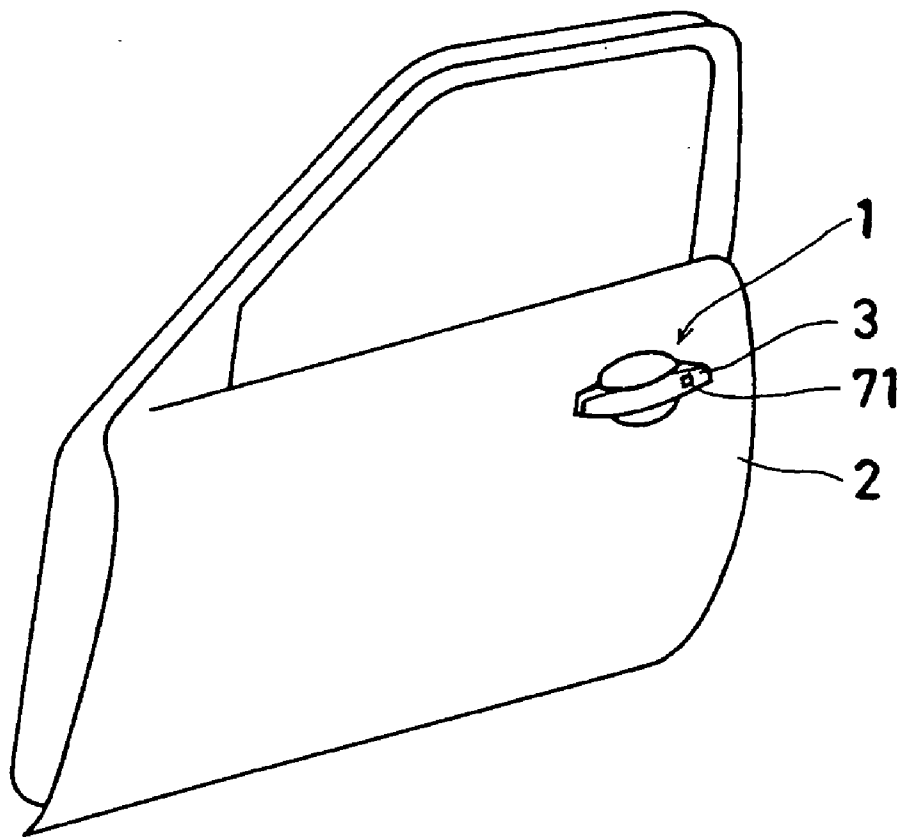

FIG. 3

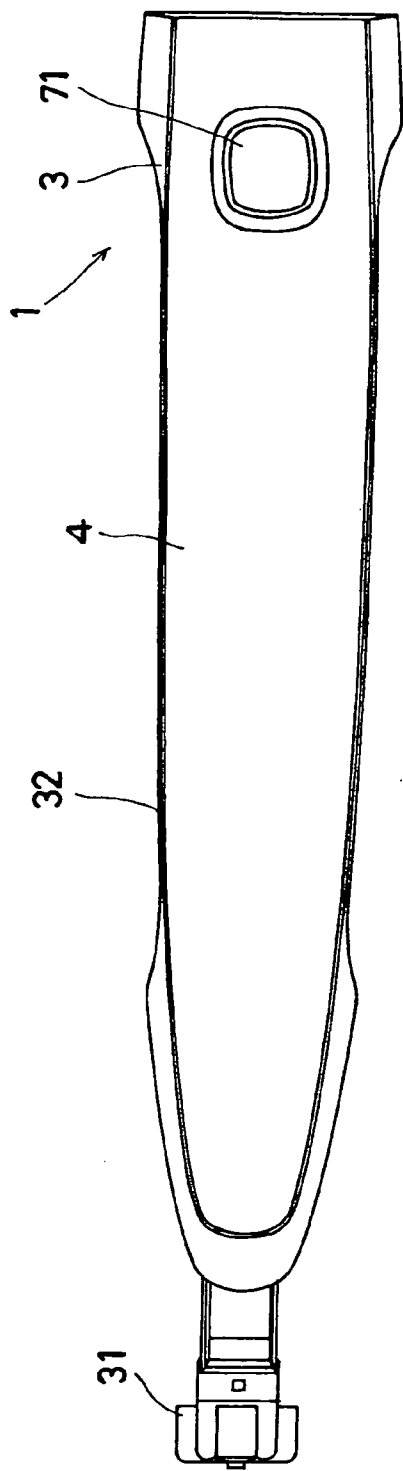

FIG. 4

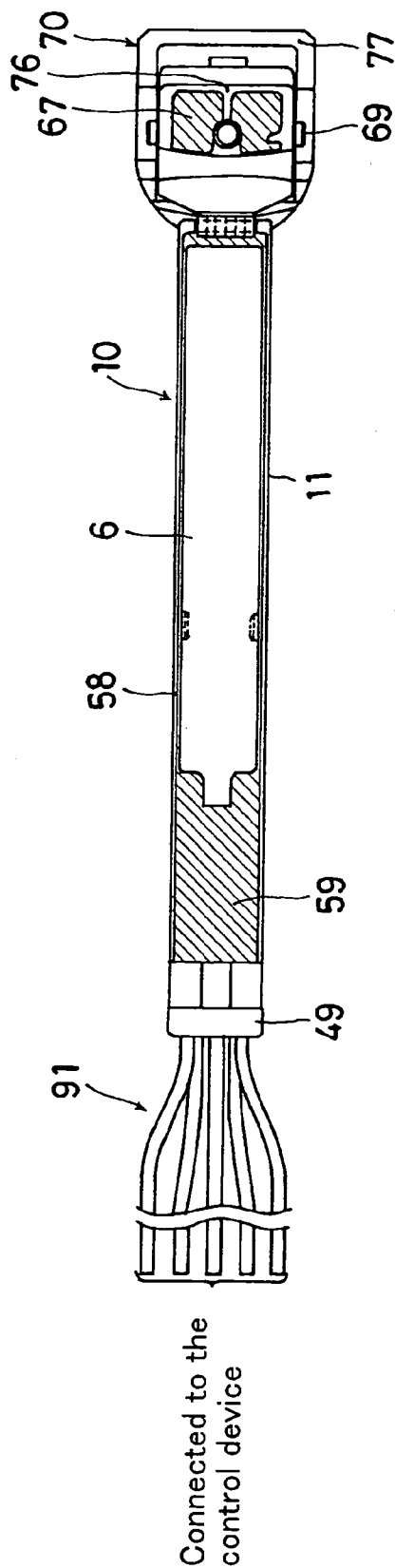

FIG. 5

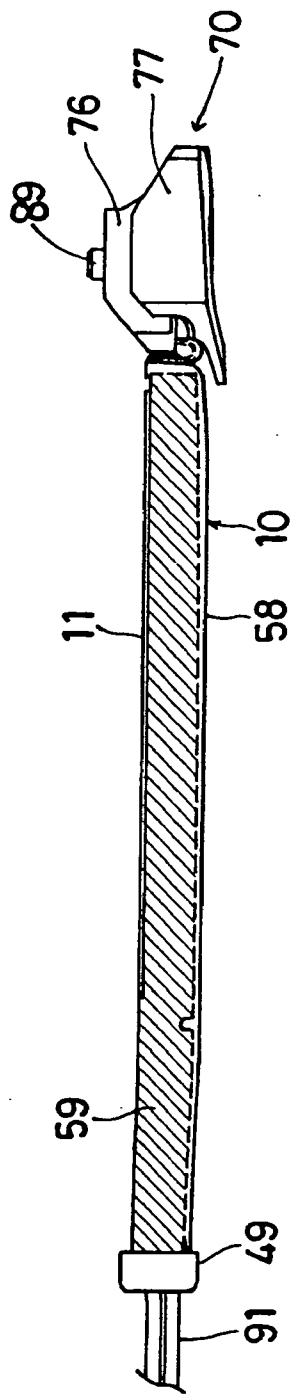

FIG. 6

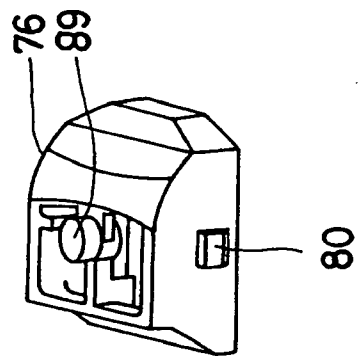

FIG. 7

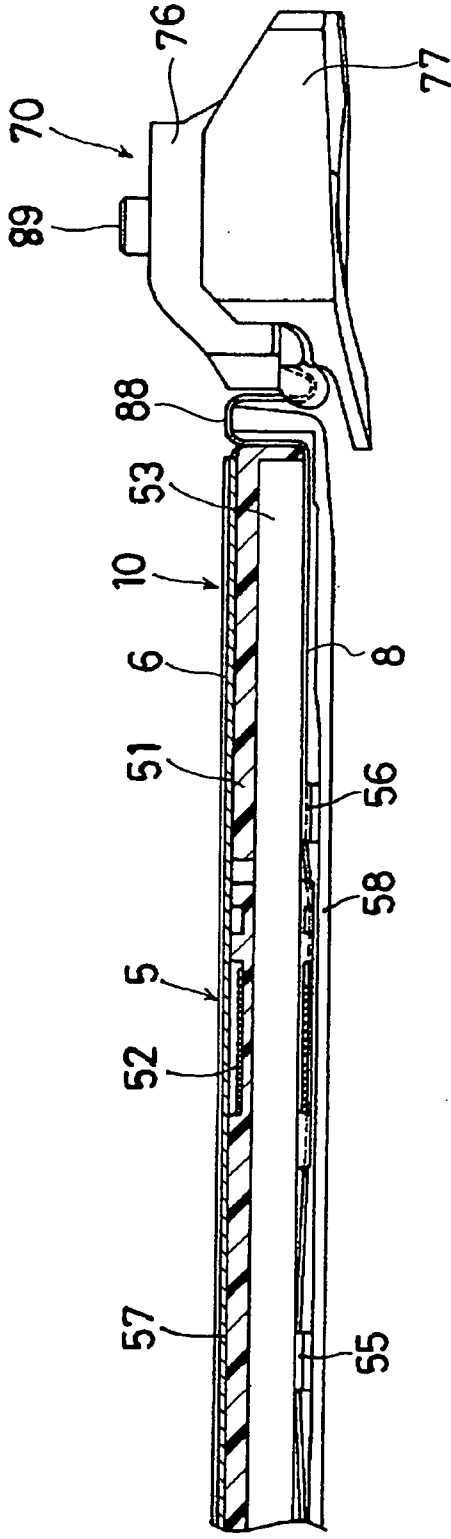

FIG. 8

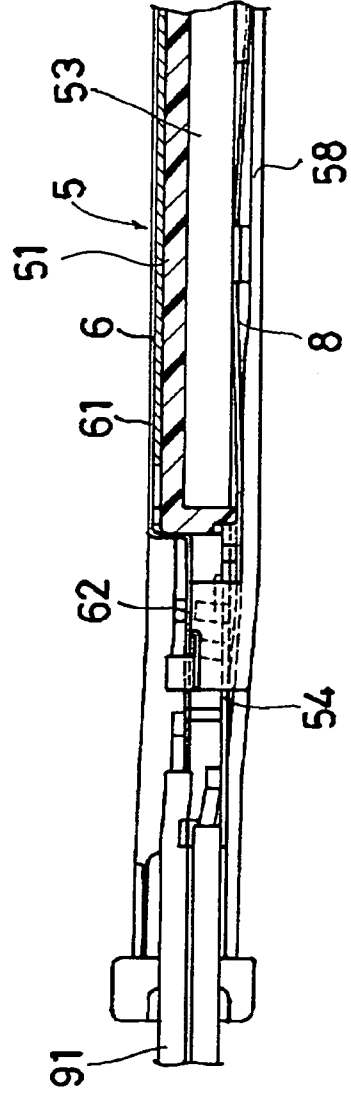

FIG. 9

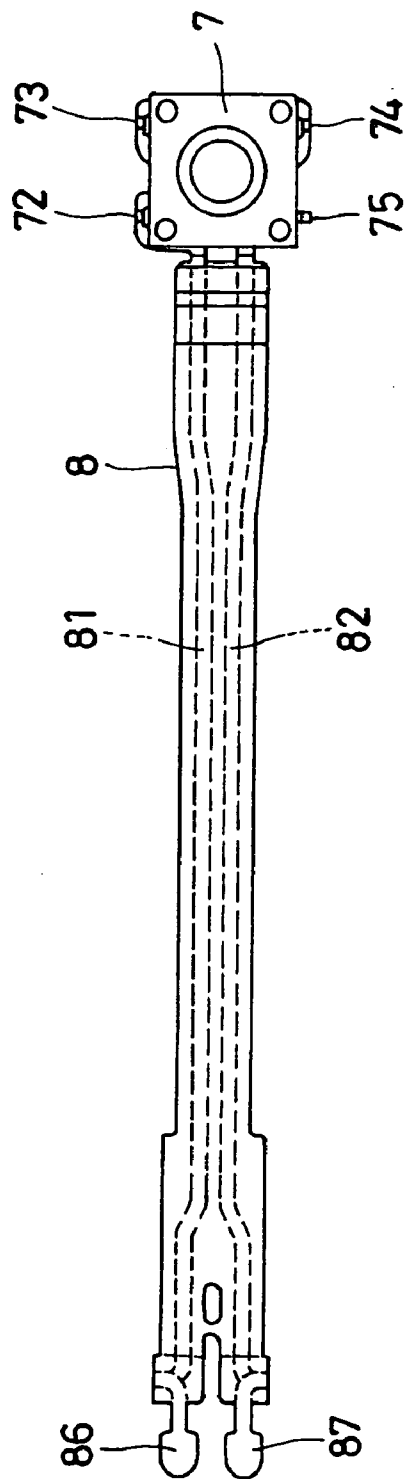

FIG. 10

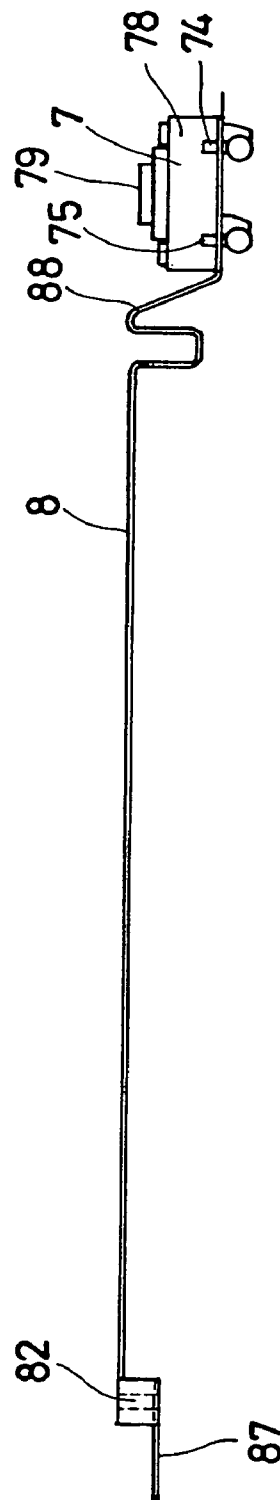

FIG. 11

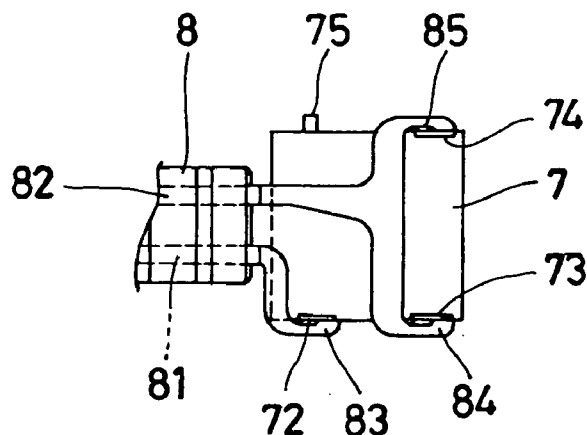

FIG. 12

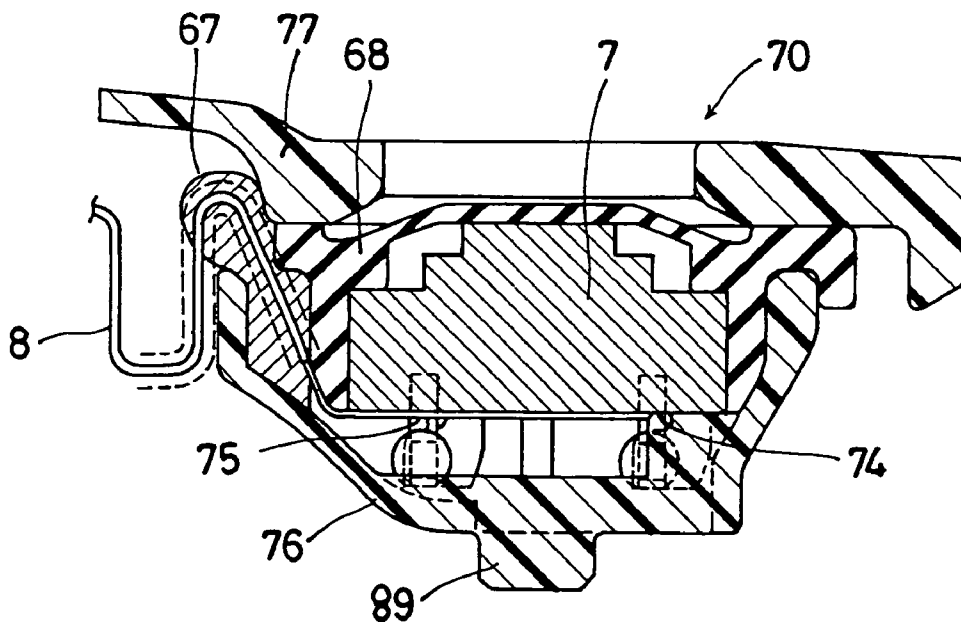

FIG. 13

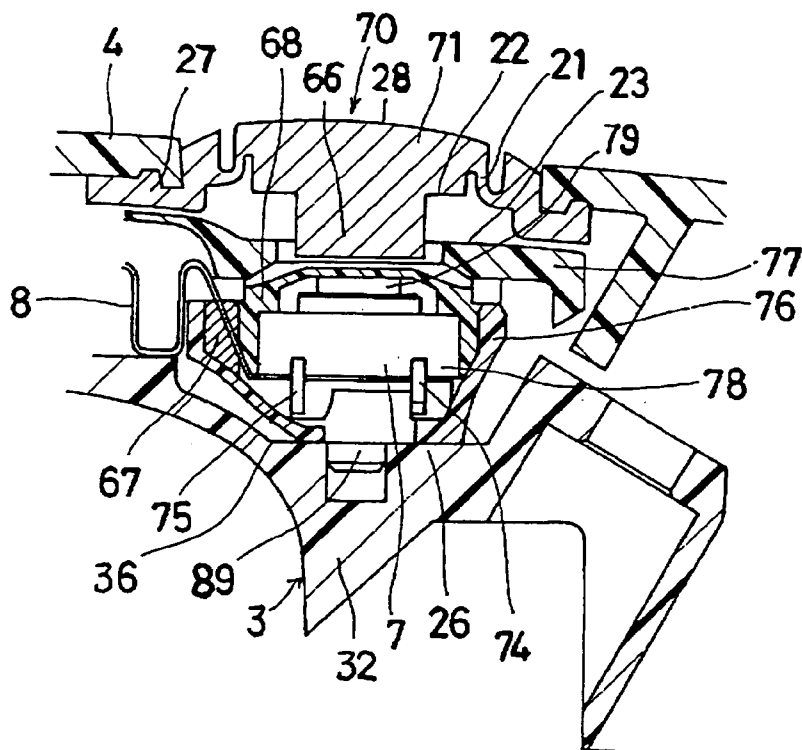
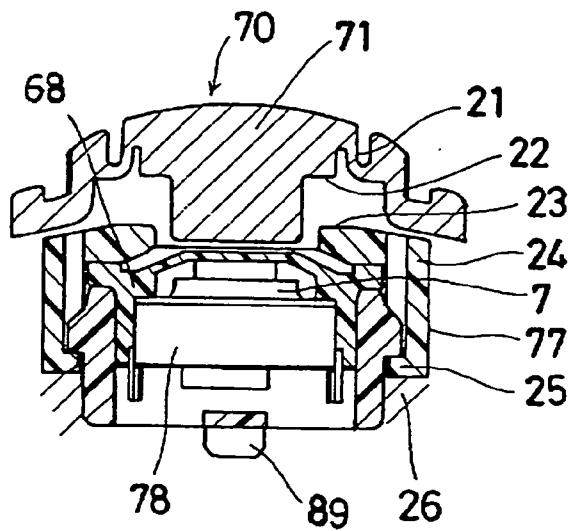

FIG. 14



PUSH SWITCH APPARATUS

[0001] This application is based on and claims priority under 35 U.S.C. § 119 with respect to Japanese Application No. 2003-117205 filed on Apr. 22, 2003, and Japanese Application No. 2003-117214 filed on Apr. 22, 2003, the entire content of which is incorporated herein by reference.

FIELD OF THE INVENTION

[0002] This invention generally relates to a push switch apparatus, more particularly for provided with a vehicle door handle device of a vehicle door.

BACKGROUND OF THE INVENTION

[0003] A known push switch apparatus is disclosed in Japanese Patent Laid-Open Publication No. 2001-182459. The push switch includes a switch case, a switch, a switch cap and a switch button. The switch is arranged in a switch case. The switch cap is supported on the switch button and is fixed to the switch case. The switch cap covers the switch for protects switch from a water. In such configuration, when the switch button is operates, the switch button pushes the switch through the switch cap. Therefore, the switch is generating a signal. However, the push switch is not considering a measure for releasing an excessive operation force relative to the switch, when the switch button is operates.

[0004] A need thus exit for a push switch includes a measure for releasing an excessive operation force.

SUMMARY OF THE INVENTION

[0005] In light of the foregoing, the present invention provides a push switch apparatus, which includes a switch case adapted to be a base member, a switch mounted on the switch case, a switch cap made of an elastic material and supported on the switch case for covering the switch, a switch button supported by the base member and having an actuating portion for pushing the switch and an switch plate mounted on the switch case and arranged between the switch cap and the switch button. The switch plate having a contact surface contacts the switch button when the actuating portion of the switch button pushes the switch.

BRIEF DESCRIPTION OF THE DRAWING FIGURES

[0006] The foregoing and additional features and characteristics of the present invention will become more apparent from the following detailed description considered with reference to the accompanying drawing figures in which like reference numerals designate like elements and wherein:

[0007] FIG. 1 illustrates a cross sectional view indicating an inner configuration of a vehicle door handle device according to an embodiment of the present invention;

[0008] FIG. 2 illustrates a perspective view indicating a vehicle door at which the vehicle door handle device shown in FIG. 1 is assembled;

[0009] FIG. 3 illustrates a front view of the vehicle door handle device according to the embodiment of the present invention;

[0010] FIG. 4 illustrates a diagram indicating a molding unit provided inside the vehicle door handle shown in FIG. 3;

[0011] FIG. 5 illustrates a side view of the molding unit shown in FIG. 4;

[0012] FIG. 6 illustrates a perspective view indicating a form of a switch case shown in FIG. 4;

[0013] FIG. 7 illustrates a partial cross sectional view indicating an inner configuration of the molding unit shown in FIG. 5;

[0014] FIG. 8 illustrates a partial cross sectional view indicating a configuration of a connecting portion of a terminal of the molding unit shown in FIG. 7;

[0015] FIG. 9 illustrates a front view indicating a switch and a flexible circuit board before molded into the molding unit shown in FIG. 4;

[0016] FIG. 10 illustrates a side view of the switch and the flexible circuit board show in FIG. 9;

[0017] FIG. 11 illustrates a partial enlarged view indicating a electrically connecting portion between the switch and the flexible circuit board shown in FIG. 9;

[0018] FIG. 12 illustrates a partial cross sectional view indicating an inner configuration of a door switch shown in FIG. 4;

[0019] FIG. 13 illustrates an enlarged partial cross sectional view indicating an inner configuration of the door switch shown in FIG. 1, and

[0020] FIG. 14 illustrates a partial cross sectional view along a center line of the door switch showing another aspect of the inner configuration of the door switch shown in FIG. 12.

DETAILED DESCRIPTION OF THE INVENTION

[0021] A preferred embodiment of the present invention will be described hereinbelow in detail with reference to the accompanying drawings.

[0022] FIG. 1 illustrates a cross sectional view indicating an internal configuration of a vehicle door handle device 1. As shown in FIG. 2, the vehicle door handle device 1 is provided at the upper rear portion of a vehicle door 2 by which a user gets in or out of the vehicle, and the vehicle door handle device 1 includes an outside handle 3 (a handle body) being shaped as shown in FIG. 3.

[0023] As shown in FIG. 1 and 2, the vehicle door handle device 1 according to this embodiment of the present invention includes the outside handle 3 in which an antenna 5, a sensor electrode 6 (an operation detecting sensor) for detecting an operation of the outside handle 3 and a door switch device 70 (a push switch apparatus) for requiring a locking action of a door lock device (not shown) of the vehicle door 2 are housed.

[0024] The outside handle 3 includes a hinge portion 31, a main body 32, a limiting portion 33 and a handle cover 4. The hinge portion 31 for rotating a rear portion of the vehicle door 2 (the right side in FIG. 1) in the vehicle width direction positioning a fulcrum at a front portion of the vehicle door 2 (the left side in FIG. 1). The main body 32 including a housing portion 3a in which the antenna 5, the sensor electrode 6, the door switch device 70 and the like are housed. The limiting portion 33 being reverse L-shaped in

the cross sectional view shown in **FIG. 1** for limiting an rotation angle of the outside handle **32** not to be exceed equal to or more than a predetermined angle.

[0025] Further, a grip portion **34** being thin at the vehicle door side is formed at the main body **32**. The housing portion **3a** opening outwardly is covered by the handle cover **4** and designing surface of the vehicle door handle device **1**. The handle cover **4** is made by a process of insert molding with two nuts inserted into a form block. The handle cover **4** is attached to the main body **32** by screwing screws **41** and **42** inserted through the main body **32** from the vehicle door side into the two nuts integrally formed at the handle cover **4**.

[0026] As shown in **FIG. 3**, the front portion of the handle cover **4** becomes gradually narrower than the rear portion thereof. The handle cover **4** having a switch button **71** of the door switch device **70** at the rear portion thereof.

[0027] Next, an inner configuration of the housing portion **3a** formed at the main body **32** and components provided inside the housing portion **3a** will be explained.

[0028] As shown in **FIG. 1**, the housing portion **3a** formed along the longitudinal direction of the main body **32** of the outside handle **3** includes an opening **35** at front portion thereof being rectangular for guiding harnesses **91** into a compartment of the vehicle. In addition, a depressed portion **36** at which a cup-shaped switch case **76** of the door switch device **70** for housing a push-type switch **7** of the door switch device **70** is formed at the rear portion of the housing portion **3a**. The depressed portion **36** is being more depressed toward the vehicle door side than a center portion of the housing portion **3a**.

[0029] As shown in **FIG. 1** and **FIGS. 3 through 5**, the door switch device **70** is positioned at a predetermined position of the depressed portion **36**. A molding unit **10** is provided at approximately center portion of the housing portion **3a**. The molding unit **10** includes a main unit portion **11**, the door switch device **70** and the five harnesses **91**. The molding unit **10** provided in the housing portion **3a**.

[0030] The five harnesses **91** of the molding unit **10** is extending from one end of the main unit portion **11** of the molding unit **10**. In addition, a grommet **49** is fitted at the harnesses **91** for water-proofing, a tube **92** is provided for bundling the harnesses **91**, and a connector **93** is attached at the end of the harnesses **91** for water-proofing as shown in **FIG. 1**.

[0031] On condition that the molding unit **10** is provided at the housing portion **3a**, the connector **93** is penetrated through the opening **35** formed at the front portion of the main body **32** and extends inside of the vehicle door **2**.

[0032] An external connector (not shown) is fitted at the connector **91** for transmitting signals to a control device (not shown). Such signals includes a lock requiring signal from the door switch device **70** provided at the housing portion **3a** and a detecting signal indicating an electric capacitance between the sensor electrode **6** and the user, which is detected at the sensor electrode **6**. At the control device, the condition of such signals are determined by a CPU provided in the controlling device, then a drive signal is transmitted to the antenna **5** provided inside the molding unit **10**, and an electric wave (e.g. ID requiring signal) is transmitted to the outside of the vehicle (e.g. to the user having the portable station).

[0033] As shown **FIGS. 7 through 14**, a configuration of the molding unit **10** provided at the housing portion **3a** will be described below. The door switch device **70** is connected to one end of the main unit portion **11**, and the harnesses **91** are connected to the other end of the main unit portion **11**. The main unit **11** includes the antenna **5**, the sensor electrode **6** and a flexible circuit board **8**, the switch **7** of the door switch device **70** is connected to the flexible circuit board **8**. The flexible circuit board **8** being made of resin (polyurethane resin) and molded integrally with the antenna **5** and the sensor electrode **6**.

[0034] A configuration of the antenna **5** will be described below. A ferrite **53** is housed in a rectangular solid antenna case **51** at which two faces are opened. The grommet **49** is attached to the one opening of the antenna case **51**, and the ferrite **53** is inserted through the other opening. A coil **52** is wound on the antenna case **51** in a direction being perpendicular to the longitudinal direction of the antenna case **51** at a predetermined winding number. In this case, the coil **52** is wound at an approximately center portion relative to the longitudinal direction of the antenna case **51** and electrically connected to two terminals **54** attached to one end of the antenna case **51** and extending in the longitudinal direction of the antenna case **51**. The antenna **5** outputs a predetermined electric wave (e.g. ID requiring signal) by applying the drive signal by the control device (not shown) and applying an electric current through the coil **52** wound on the antenna case **51**. Thus, the antenna **5** works as an output antenna, however, such antenna **5** may additionally includes a function as a receiving antenna.

[0035] A configuration of the switch **7** of the door switch device **70** will be explained below. As shown in **FIGS. 9 through 11**, the switch **7** including a switch main unit **78**, a pressed portion **79**, and four terminals **72, 73, 74** and **75** is electrically connected to the flexible board **8**. The flexible board **8** includes conductive patterns **81** and **82** made of conductive material like tin. The conductive patterns **81** and **82** are integrally flattened by resin film such as polyethylene. The flexible board **8** also includes edge portions **83, 84, 85, 86** and **87** at which the conductive patterns **81** and **82** are exposed. As shown in **FIG. 9**, the exposed edge portions **86** and **87** on one side of the conductive patterns **81** and **82** are caulked at caulking portions thereof, then the two harnesses **91** are connected to the caulking portions by resistance welding. On the other hand, the edge portions **83, 84** and **85** on the opposite side of the conductive patterns **81** and **82** are connected to three terminals **72, 73** and **74** of the four terminals **72, 73, 74** and **75** by resistance welding as show in **FIG. 11**. Specifically, the edge portion **83** of the conductive pattern **81** is connected to the terminal **72** of the door switch device **70**. The edge of the conductive pattern **82** on the switch side is bifurcated into two and forms an edge portions **84** and **85** at the back side of the door switch device **70**, and the edge portion **84** is connected to the terminal **73** of the door switch device **70**, and the edge portion **85** is connected to the terminal **74** of the door switch device **70**. In this case, the terminals **72, 73** and **74** are connected by the resistance welding, however, the terminals may be connected electrically by soldering alternatively.

[0036] The end portions **86** and **87** of the flexible board **8** are bent in orthogonal direction relative to the longitudinal direction of the flexible board **8** to be like a pair of parentheses in cross sectional view of **FIG. 10**, so that the

end portions **86** and **87** become terminals at which the harnesses **91** are caulked respectively. The flexible board **8** also includes an adjusting portion **88** at which the flexible board **8** is bent to be approximately S-shaped in **FIG. 10** for adjusting the position of the door switch device **70** connected to the rear (right) portion of flexible board **8**.

[0037] As shown in **FIGS. 4 through 7** and **FIGS. 12 through 14**, the switch **7** is housed in the switch case **76** being shaped as show in **FIG. 6**. The switch case **76** includes two openings at the bottom portion thereof (upper portion in **FIG. 6**), and a cylindrical projecting portion **89** being projecting outwardly at the center portion of the bottom portion of the switch case **76** for positioning the switch case **76** relative to the depressed portion **36** formed at the housing portion **3a** of the out side handle **3**. Thus, the switch **7** is housed in the switch case **76** at a predetermined position. The switch case **76** also includes an opening at the opposite side where the two opening are provided, and the switch **7** is inserted through the opening from the above direction in **FIG. 1**. In addition, a switch cap **68** is fitted to the switch case **76** for covering the opening in order to dampproof the switch **7**.

[0038] The center portion of the switch cap **68** being made of elastomer such as synthesized resin and rubber is thin, so that it is deformed being fitted into the switch case **76**. In addition, a switch plate **77** (intermediate member) is fitted to the switch case **76** being covered by the switch cap **68**. The switch plate **77** includes a depressed portion being approximately a cup-formed at which the switch case **76** is fitted. In this case, the switch case **76** including a pair of pawl portion **80** at both sides thereof as shown in **FIG. 6** is integrally fixed to the switch plate **77** by the pawl portion **80** being fitted into a pair of groove-formed fitting portion **69** formed inside of the switch-plate **77**. In such condition, polyurethane resin fills inside the switch case **76** through two openings formed at the bottom portion of the switch case **76** next to the projecting portion **89**. The polyurethane resin fills around the switch main unit **78** of the switch **7** except the pressed portion **79**, in other words the pressed portion is uncovered by the polyurethane resin. Thus, the connecting portion between the switch **7** and the flexible board **8** are fixed with the polyurethane resin.

[0039] As shown in **FIGS. 1 through 14**, the door switch device **70** is assembled as follows. First, the flexible board **8** is connected to the switch **7** shown in **FIG. 9**, then the switch case **76** and the switch cap **68** are assembled to the door switch device **70**. Next, the pawl portion **80** of the switch case **76** is engages with the switch plate **77**, thus the switch plate **77** is assembled to the switch case **76** to be a sub-assembly (sub-assay). The flexible board **8** of the sub-assay being engaged with the side surface of the ferrite **53** is engaged with two engaging portions **55** and **56** formed at the antenna case **51**. Thus the flexible board **8** is fixed to the antenna case **51**. The sensor electrode **6** is fixed to the opposite side of the bottom portion where the ferrite **53** of the antenna case **51** is housed by means of a double stick tape.

[0040] The sensor electrode **6** includes a rectangular detecting portion **61** provided along the longitudinal direction of the antenna case **51** and a terminal portion **62** continually extending from the detecting portion **61**. A portion between the detecting portion **61** and the terminal

portion **62** is bent to be crank-shaped, and the end portion of the terminal portion **62** further extends in the extending direction of the terminal **54** at which the end portion of the coil **52** is connected keeping a predetermined clearance therebetween. In this case, one of five harnesses **91** at which the grommet **49** is fitted is connected to the end portion of the terminal portion **62** of the sensor electrode **6** by resistance welding. Thus, the flexible board **8** at which the switch **7** is connected is fixed to the antenna case **51**, then an assembly unit including an antenna case **51** at which the sensor electrode **6** is mounted is made, and the assembly unit is housed into a rectangular molding case **58** having an opening at one side thereof. Polyurethane resin **59** fills into the molding case **58** housing the assembling unit. In this way, the molding unit **10** being resin molded is formed by integrally molded the flexible board **8** including the door switch device **70** at the one end thereof, the antenna **5** and the sensor electrode **6**. The grommet **49** if fitted at the harness side of the molding case **58** for preventing water coming into the molding case **58** from the periphery of the harnesses **91**. As shown in **FIG. 4** and **FIG. 5**, the resin **59** fills the connecting portion between the harnesses **91** and the molding unit **10** and around the antenna for securing the electrically connection of the connecting portion. In addition, the door switch device **70** is also filled with the resin as aforementioned before. The switch case **76** is filled with the resin **67** being same polyurethane sealing as the resin **59** through the two openings formed next to the cylindrical projecting portion **89** of the switch case **76**. In this way, the switch main unit **78** of the switch **7** is fixed at the predetermined position inside the switch case **76**, at the same time, the switch **7** is sealed for preventing water coming inside thereof.

[0041] The molding unit **10** having an aforementioned configuration is engaged with the bottom portion of the inner side of the grip portion **34** at the sensor electrode side thereof and provided inside the housing portion of the outside handle **3**. The door switch device **70** is positioned by the projecting portion **89** of the switch case **76** being engaged with a positioning portion at the center of the depressed portion **36** formed at the housing portion **3a** of the outside handle **3**. Thus, the molding unit **10** is provided along the housing portion **3a**.

[0042] A cushion material **9** is applied to the center portion of the molding unit **10** at the opposite side thereof where the sensor electrode **6** is provided. The switch button **71** made of rubber material includes an operating portion being approximately quadrangular-shaped and a boss portion **66** (actuating portion) at the lower center portion thereof in **FIG. 1**. The switch button **71** is assembled at the rear portion of the handle cover **4** from the vehicle door side.

[0043] The handle cover **4** at which the switch button **71** is fitted is assembled to the outside handle **3** for covering the opening of the housing portion **3a** of the outside handle **3**. The handle cover **4** is fixed to the main body **32** of the outside handle **3** by screwing the two screws **41** and **42** into the nuts integrally provided at the handle cover **4** from the vehicle door side of the outside handle **3**. Thus, the vehicle door handle device **1** is configured with the outside handle in which the antenna **5**, the sensor electrode **6**, the door switch device **70** are integrally mounted.

[0044] An example of the operation of the vehicle door handle device will be explained as follows.

[0045] When the user approaches the vehicle and being within the predetermined area, the vehicle and the user becomes a transmittable condition. In such condition, the vehicle outputs a predetermined signal (e.g. ID requiring signal) to the portable station possessed by the user from the antenna 5 for requiring the portable station to output a signal. The portable station receives the signal from the vehicle and outputs an ID signal (various kinds of signals depending on each vehicle) to the vehicle. The vehicle receives the signal from the portable station and compares to information registered in advance. If the controlling device determined that the received ID signal is the registered ID (the user is qualified), the sensor electrode 6 detects whether or not the user demands operating the outside handle 3. In other words, generally the user puts their hand on the grip portion 34 of the outside handle 3 when the user opens or closes the vehicle door 2 (user demands operating), so that the sensor electrode 6 detects the user's intension to operates the vehicle door 2 depending on the electric capacitance between the user's hand and the sensor electrode 6. When the control device determines a distance between the user's hand and the sensor electrode 6 becomes within the predetermined range, the control device determines that the user intends to open the vehicle door 2 and actuates the door lock device to be unlocked.

[0046] On the other hand, when the user get out and close the vehicle door 2, the vehicle door 2 is locked by pressing the switch button 71 without inserting the key into the key cylinder provided at the vehicle door 2 and rotating it. Once the switch button 71 is pressed by the user, the boss portion 66 being integrally provided with the switch button 71 is pressed, then the switch cap 68 provided below the boss portion 66 in FIG. 1 is also pressed. The pressure applied to the switch cap 68 is also applied to the pressed portion 79 of the switch 7 provided below the switch cap 68. In this way, the pressed portion 79 is pressed. The contacting condition of the switch 7 is turned on or off depending on the number that the pressed portion 79 is pressed. When a signal indicating the contacting condition of the door switch device 70 is transmitted into the controlling device, the door lock device (not shown) is actuated depending on determined condition of the switch. Thus, the condition of the door lock device for prohibiting the open/close operation relative to the vehicle door 2 is locked.

[0047] As shown in FIGS. 12 through 14, the door switch device 70 is structured to transmit an excessive pressure applied to the switch button 71 to an outside handle 3 efficiently when a user strongly presses the switch button 71, the handle cover 4 being mounted to the main body 32 of the outside handle 3 includes the opening at the rear portion thereof, and the switch button 71 is fitted into the opening from the vehicle door side as shown in FIG. 13 and FIG. 14. The switch button 71 includes a fitting portion 27 being rectangular-formed and engaged with the handle cover 4, an operating portion 28 being thick and formed inside the fitting portion 27, a thin portion 21 provided between the fitting portion 27 and the operating portion 28, and the boss portion 66 provided at the lower portion of the operating portion 28 in FIG. 13. The boss portion 66 being projecting toward the switch side has a smaller diameter than the operating portion 28 has. Once the operating portion 28 of the switch button 71 is pressed, the boss portion 66 penetrates through an opening formed at the switch plate 77 and having larger diameter than the diameter of the boss portion

66. Then, a switch cap 68 is pressed by the boss portion 66, and the pressed portion 79 of the switch 7 is pressed, as a result, the switch 7 is actuated.

[0048] A surface of a switch case 76 at which the projecting portion 89 is formed engages with the bottom surface of the depressed portion 36 for positioning the switch case 76. The switch cap 68 is provided between the switch case 76 and the switch plate 77 for preventing water coming inside the switch case 76. When the operating portion 28 of the switch button 71 is pressed, the thin portion 21 of the switch button 71 is deformed, then the operating portion 28 of the switch button 71 can moved toward the switch side until a surface 23 of the switch plate 77 at which the opening is formed engages with a surface 22 being at inner side of the operating portion 28 of the switch button 71 as shown in FIG. 13.

[0049] Thus, when the user pressed the switch button 71, and excessive operation force being equal to or more than a predetermined load is applied to the operating portion 28, the boss portion 66 presses and actuates the pressed portion 79 of the switch 7, at the same time, the excessive operation force is applied to surface 23 provided at the peripheral edge of the opening formed at the switch plate 77 due to the engagement between the surface 22 of the operating portion 28 and the surface 23 of the switch plate 77. The excess load applied to the surface 23 is further applied to the peripheral portion of the switch cap 68 in the direction which the pressed portion 79 of the switch 7 is moved, then the excess load is applied to one end portion (at which the switch cap 68 is engaged) of the switch case 76. Because the switch case 76 is supported by the depressed portion 36 of the main unit portion 32, the excess load escapes to a load receiving portion 26 of the main unit portion 32 being engaged with the switch case 76.

[0050] In this case, the switch case 76 are fitted into the approximately cup-shaped depressed portion of the switch plate 77, and an outer peripheral edge of the depressed portion being cup-shaped works as a load loosing portion 24. In this way, a stroke of the operation of the operating portion 28 is limited by the switch plate 77 for protecting the switch 7 by preventing the excessive load applied to the pressed portion 79 of the switch 7 depending on the moving amount of the operating portion 28.

[0051] As aforementioned above, a range of movement of the operating portion 28 becomes equal to a range of movement of the surface 22 of the operating portion 28 until it engages with the surface 23 of the switch plate 77. When the operating portion 28 of the switch button 71 made of rubber is pressed and moved, a top end of the boss portion 66 of the switch button 71 firstly engages with the switch cap 68. As the operating portion 28 is further pressed, the switch cap 68 is deformed by the boss portion 66 being deformed due to the engagement. The movement of the operating portion 28 is stopped when the pressed portion 79 of the switch 7 is pressed to the deepest position. In such condition, a movable area in which the contacting state of the switch 7 is not damaged can be set based on a tolerance of the component of the door switch device 70.

[0052] Alternatively, it may be set in advance that the door lock device is locked or unlocked depending on the number that the switch button 71 is pressed. In addition, a prede-

terminated time may be provided between the last operation of the switch button 71 and the locking or unlocking operation of the vehicle door 2.

[0053] In the embodiment of the current invention, the grip-type outside handle is used, however, the type of the outside handle is not limited to such configuration. A pull-up type outside handle may be used alternatively.

[0054] The principles, preferred embodiment and mode of operation of the present invention have been described in the foregoing specification. However, the invention which is intended to be protected is not to be construed as limited to the particular embodiments disclosed. Further, the embodiments described herein are to be regarded as illustrative rather than restrictive. Variations and changes may be made by others, and equivalents employed, without departing from the spirit of the present invention. Accordingly, it is expressly intended that all such variations, changes and equivalents which fall within the spirit and scope of the present invention as defined in the claims, be embraced thereby.

What is claimed is:

1. A push switch apparatus comprising:

a switch case adapted to be a base member;

a switch mounted on the switch case;

a switch cap made of an elastic material and supported on the switch case for covering the switch; and

a switch button supported by the base member and having an actuating portion for pushing the switch

characterized in that

an switch plate mounted on the switch case and arranged between the switch cap and the switch button, the switch plate having a contact surface contacts the switch button when the actuating portion of the switch button pushes the switch.

2. A push switch apparatus according to claim 1, wherein the base member is a handle body be adapted to a vehicle door.

3. A push switch apparatus according to claim 2, wherein the handle body providing an antenna and an operation detecting sensor.

4. A push switch apparatus according to claim 3, the switch is electrically connected with a flexible circuit board, a coil of the antenna is electrically connected with the flexible circuit board, and the operation detecting sensor is electrically connected with the flexible circuit board, respectively.

* * * * *