



US 20130176833A1

(19) **United States**  
(12) **Patent Application Publication**  
**KAWASHIMA**

(10) **Pub. No.: US 2013/0176833 A1**  
(43) **Pub. Date: Jul. 11, 2013**

(54) **QUARTZ CRYSTAL UNIT, QUARTZ CRYSTAL OSCILLATOR AND ELECTRONIC APPARATUS**

**Publication Classification**

(71) Applicant: **PIEDEK TECHNICAL LABORATORY, Tokyo (JP)**  
(72) Inventor: **Hirofumi KAWASHIMA, Tokyo (JP)**  
(73) Assignee: **PIEDEK TECHNICAL LABORATORY, Tokyo (JP)**  
(21) Appl. No.: **13/743,471**  
(22) Filed: **Jan. 17, 2013**

(51) **Int. Cl.**  
**H01L 41/08** (2006.01)  
**H03B 1/04** (2006.01)  
**G04B 17/00** (2006.01)  
**H01L 41/053** (2006.01)  
(52) **U.S. Cl.**  
CPC ..... **H01L 41/08** (2013.01); **H01L 41/053** (2013.01); **H03B 1/04** (2013.01); **G04B 17/00** (2013.01)  
USPC ..... **368/168**; 310/348; 331/156

**Related U.S. Application Data**

(63) Continuation of application No. 12/657,151, filed on Jan. 14, 2010, now Pat. No. 8,358,052, which is a continuation-in-part of application No. 12/009,284, filed on Jan. 17, 2008, now Pat. No. 7,723,904, which is a continuation of application No. 11/607,276, filed on Nov. 30, 2006, now Pat. No. 7,342,352, which is a continuation of application No. 10/875,114, filed on Jun. 23, 2004, now Pat. No. 7,193,354.

**Foreign Application Priority Data**

Jun. 30, 2003 (JP) ..... 2003-205844  
Dec. 5, 2003 (JP) ..... 2003-436310

(57) **ABSTRACT**

In a quartz crystal unit, the unit comprising a quartz crystal resonator having a base portion, and first and second vibrational arms connected to the base portion, at least one groove being formed in at least one of opposite main surfaces of each of the first and second vibrational arms, a length of the base portion being less than 0.5 mm and an overall length of the quartz crystal resonator being less than 2.1 mm, at least one mounting arm protruding from the base portion and being formed between the first and second vibrational arms, the at least one mounting arm extending in a common direction with the first and second vibrational arms.

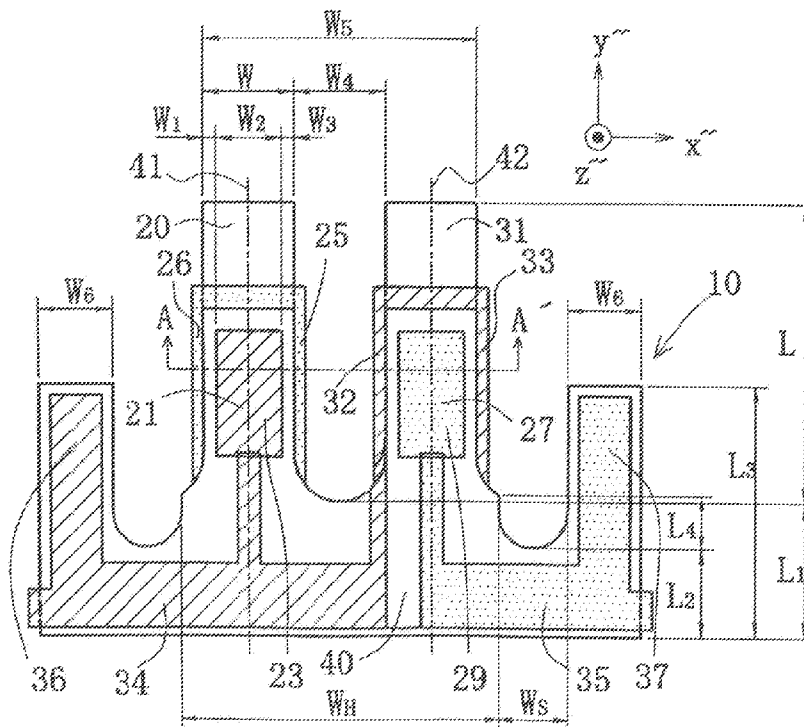

FIG. 1

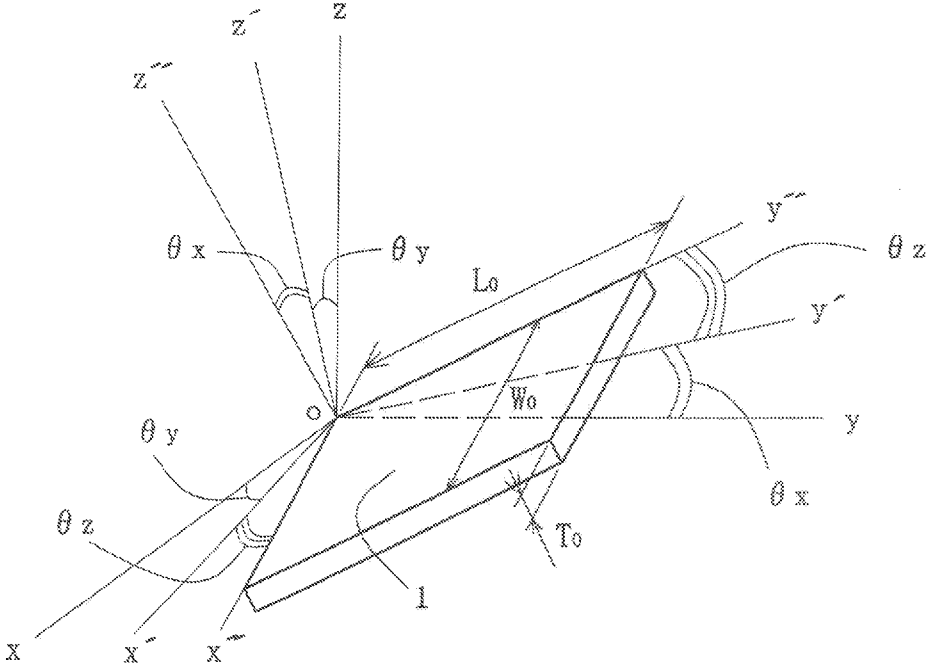





FIG. 4

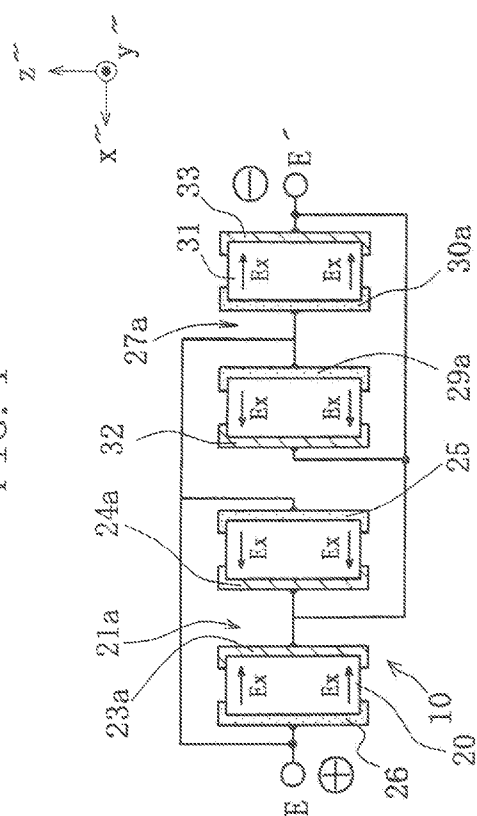

FIG. 5

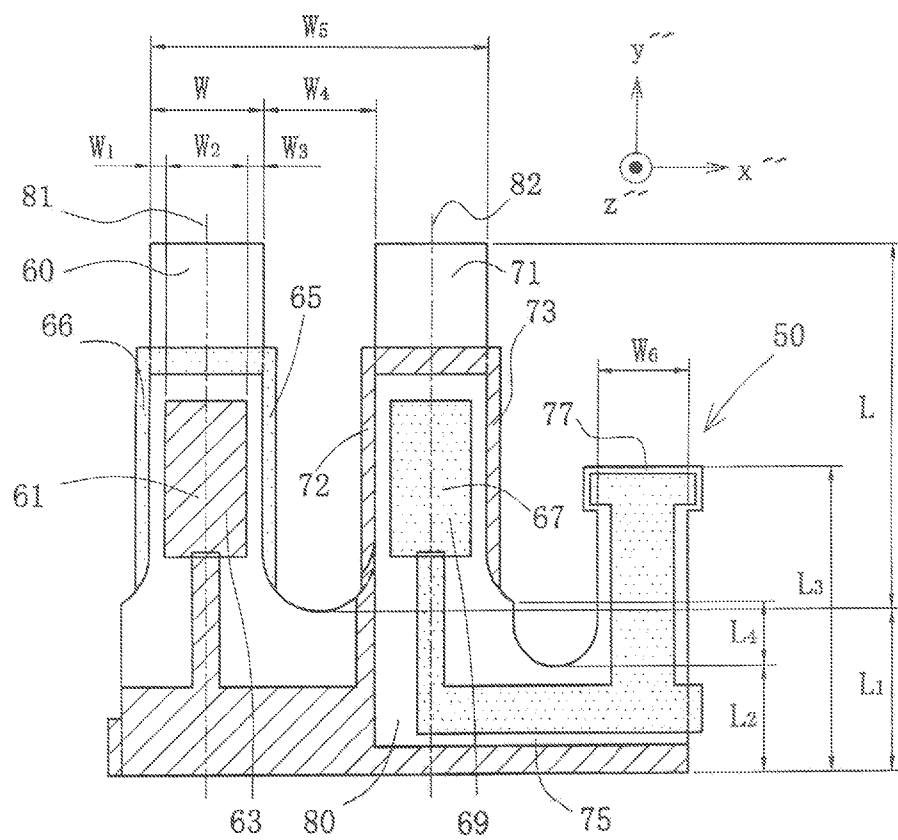

FIG. 6

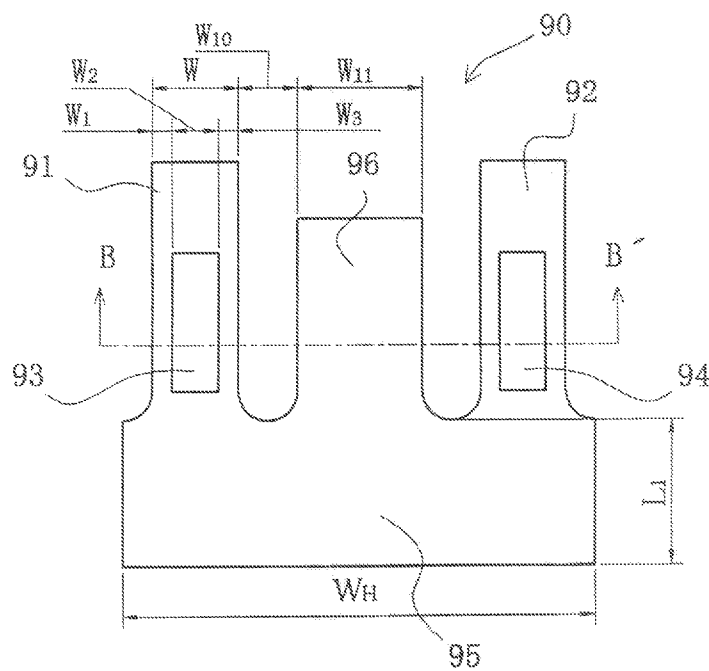

FIG. 7

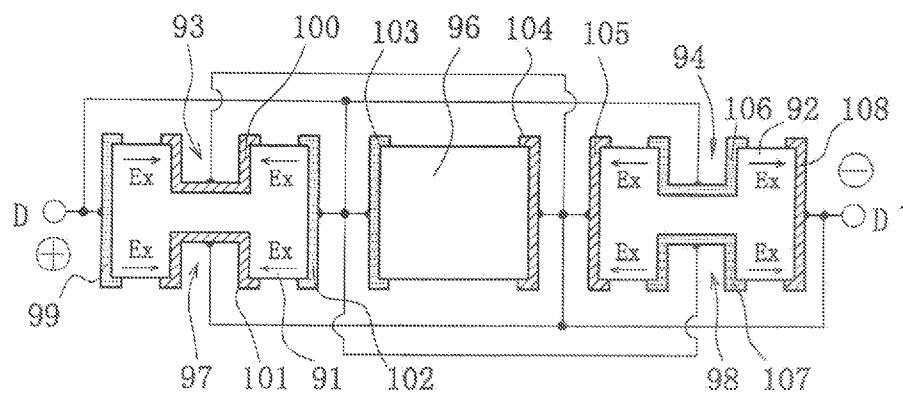



FIG. 8

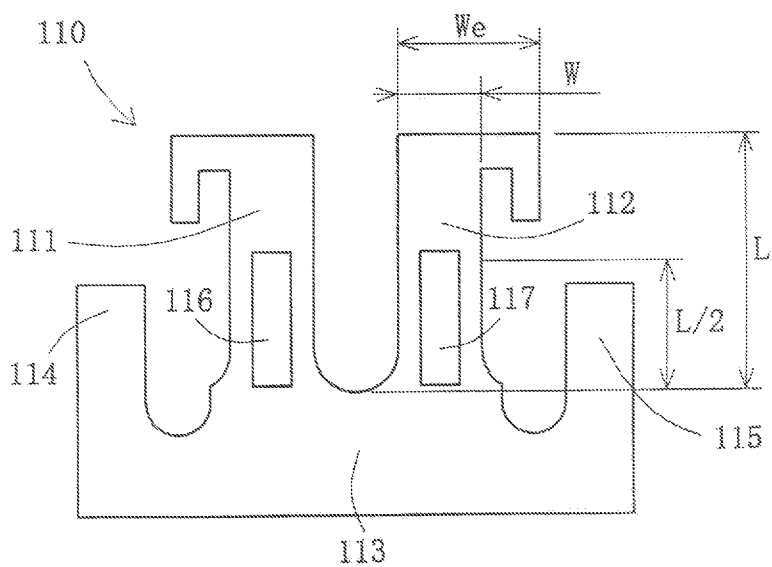

FIG. 9

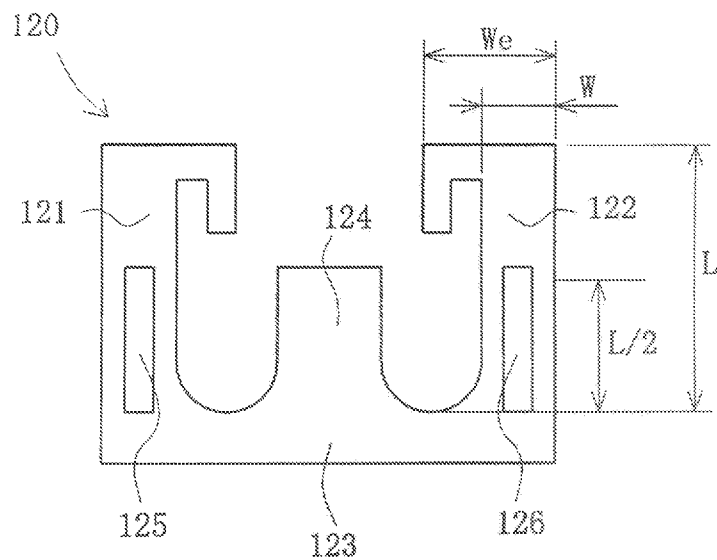

FIG. 10

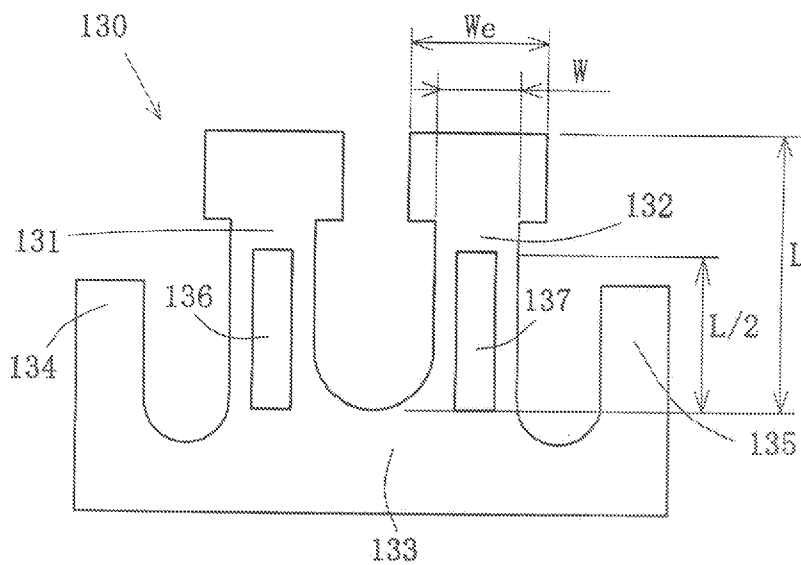

FIG. 11

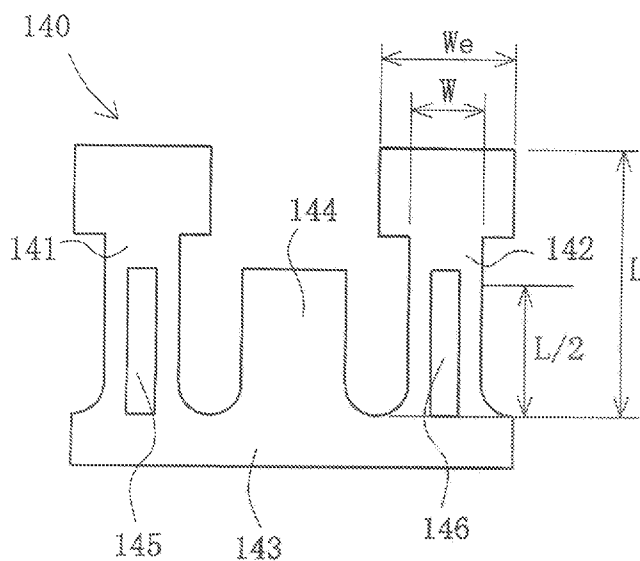

FIG. 12

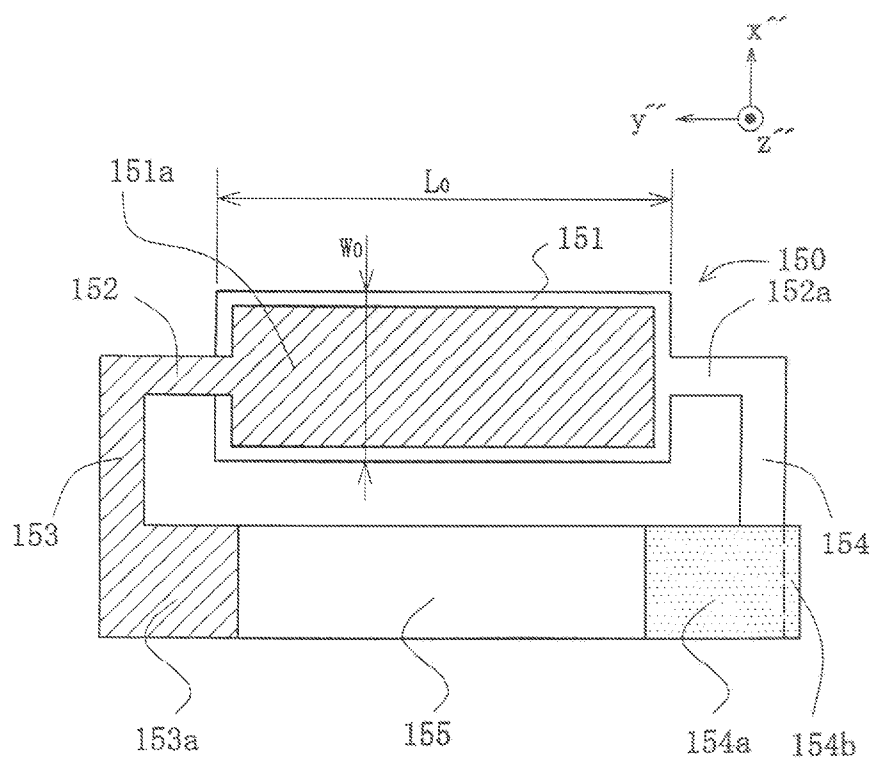

FIG. 13

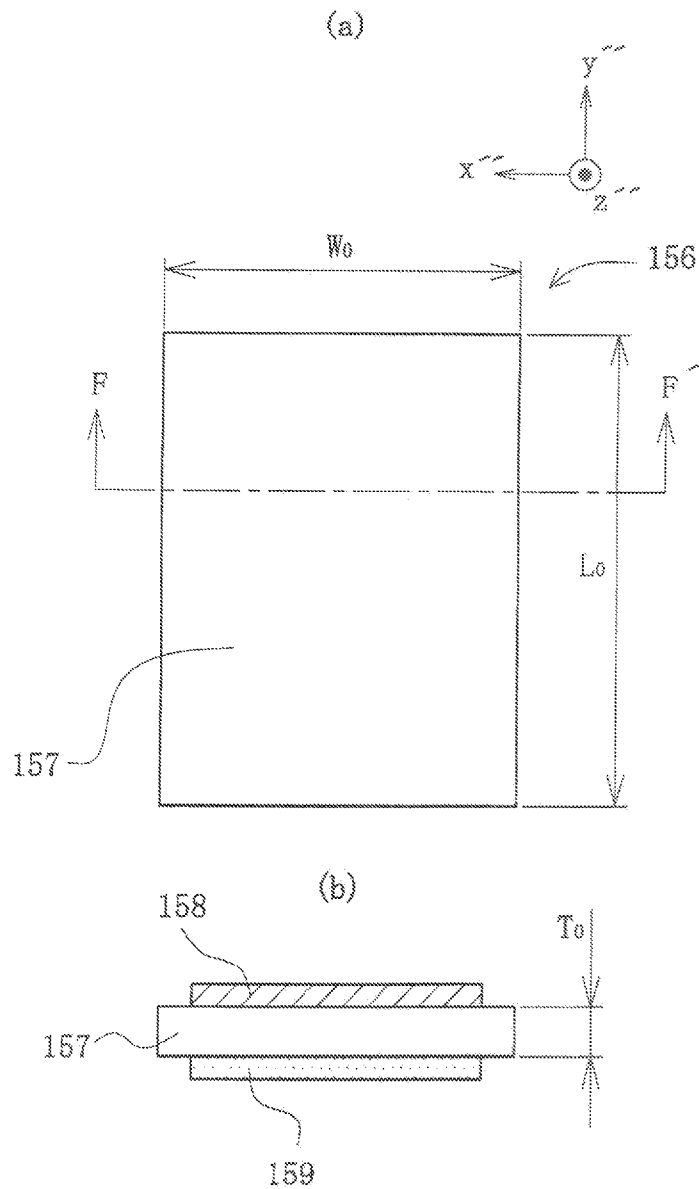

FIG. 14

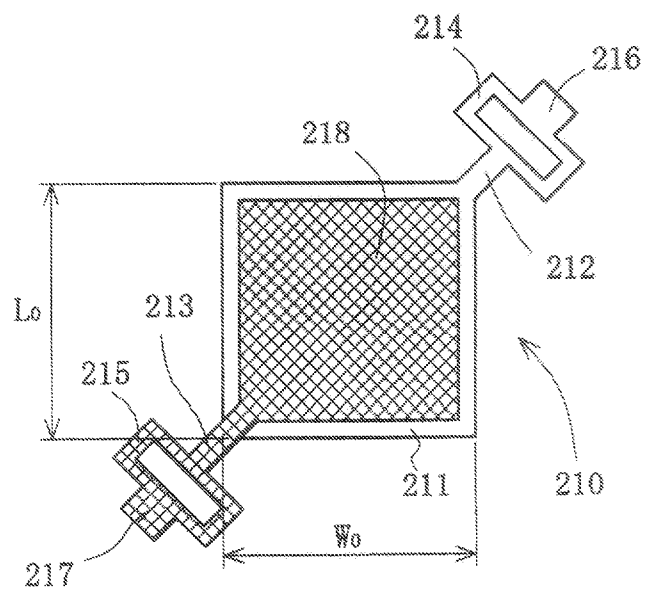

FIG. 15

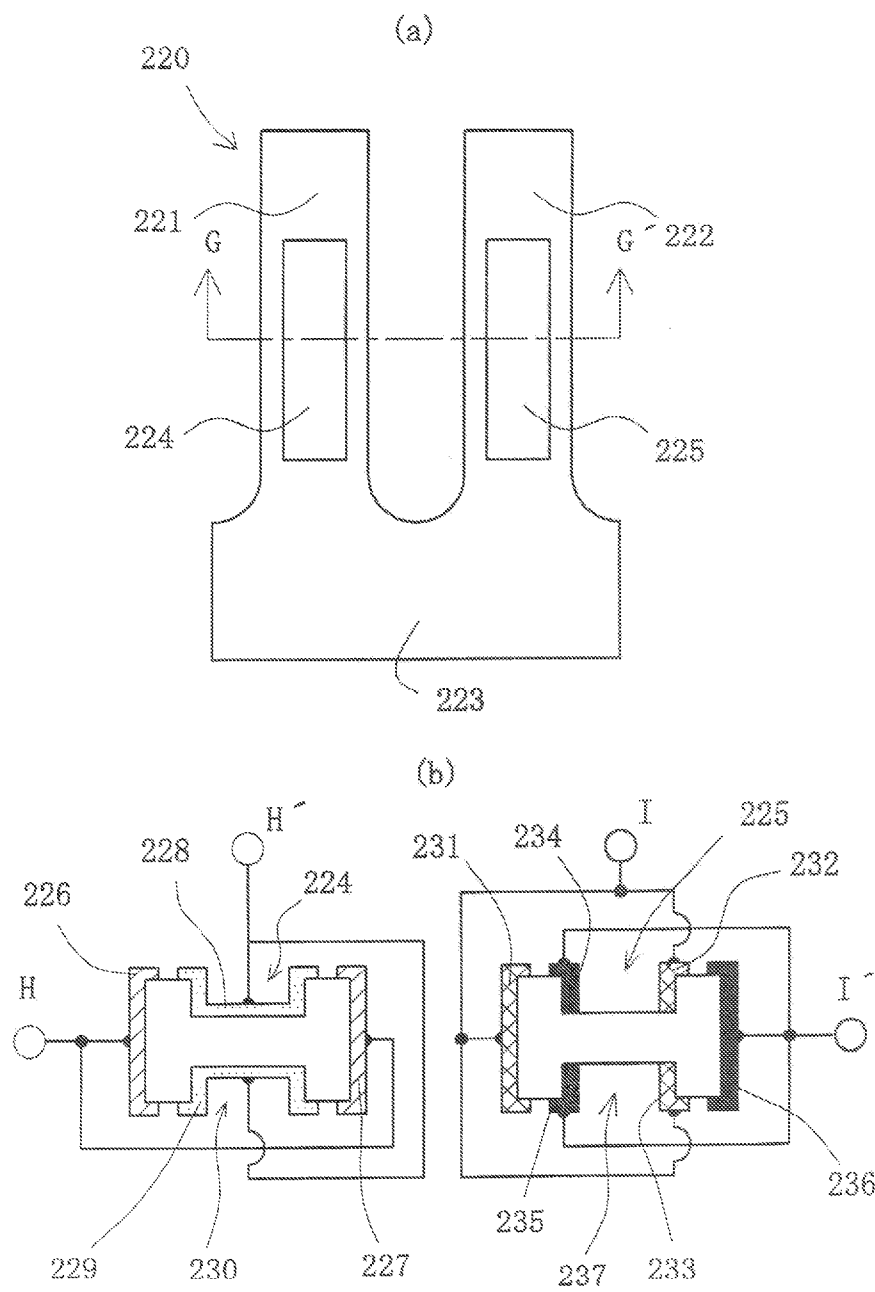



FIG. 16

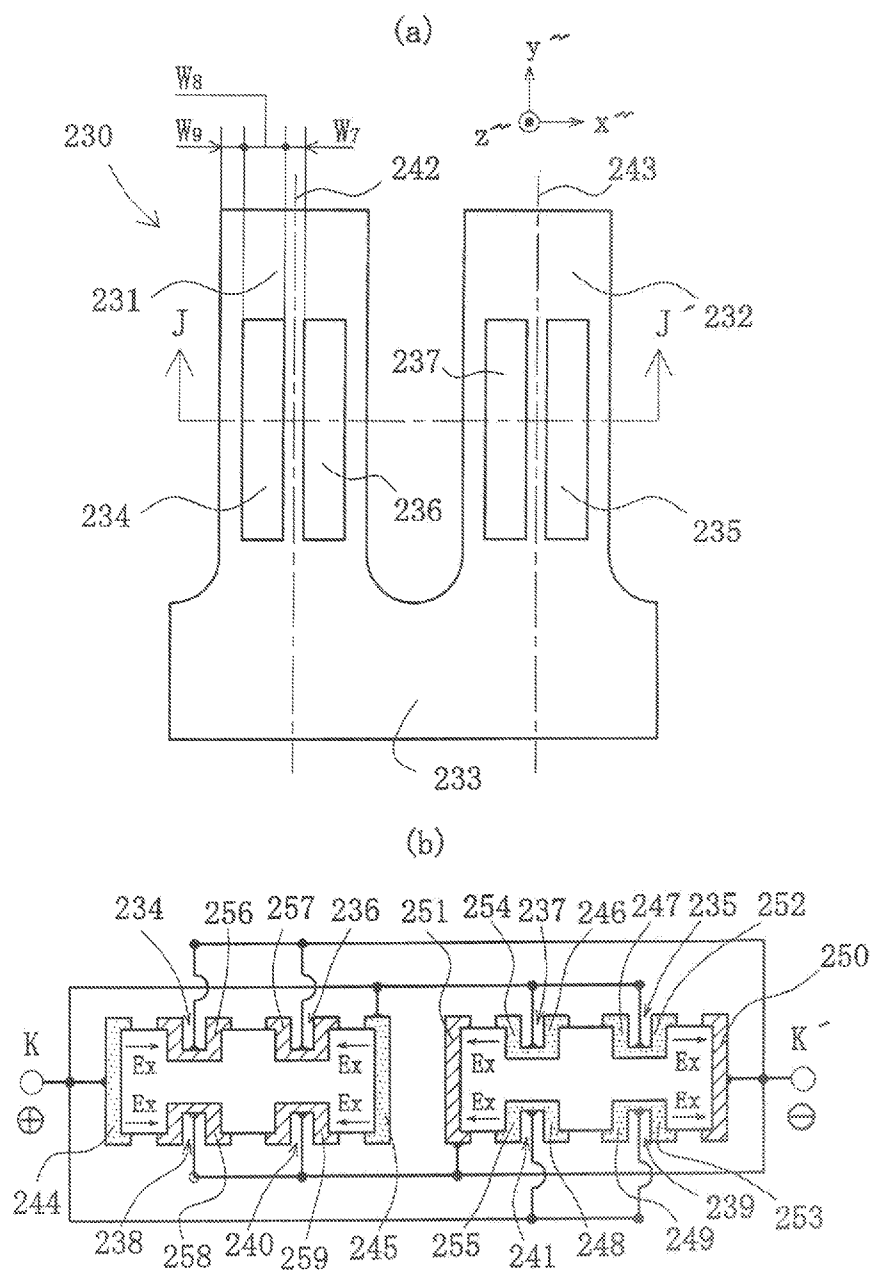

FIG. 17

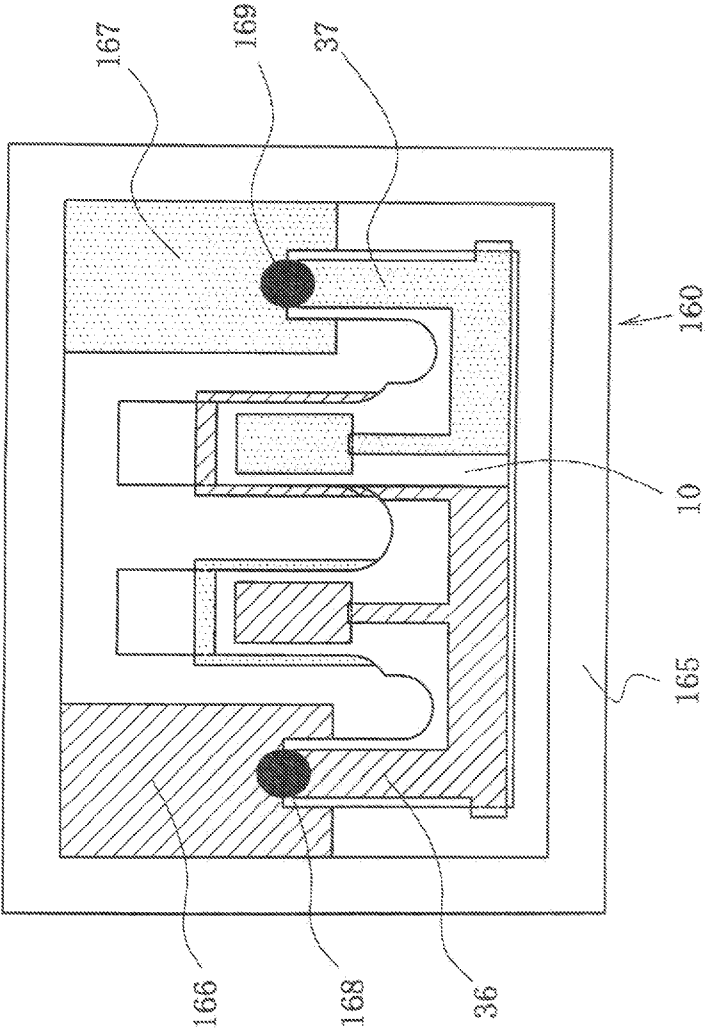

FIG. 18

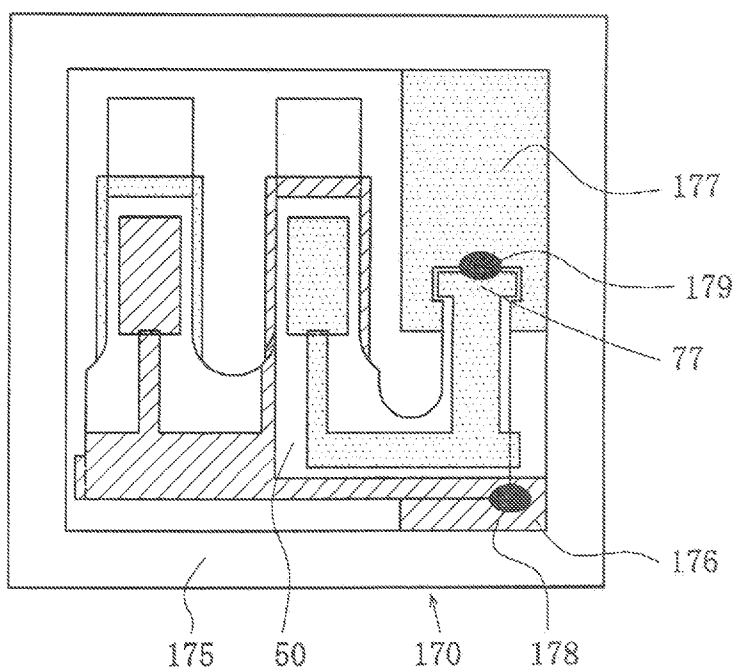

FIG. 19

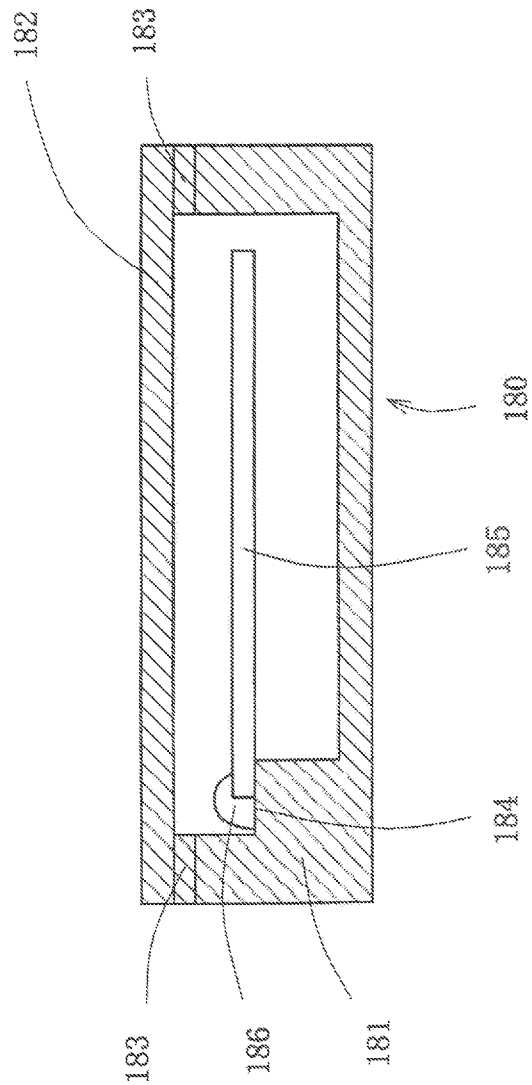



FIG. 21

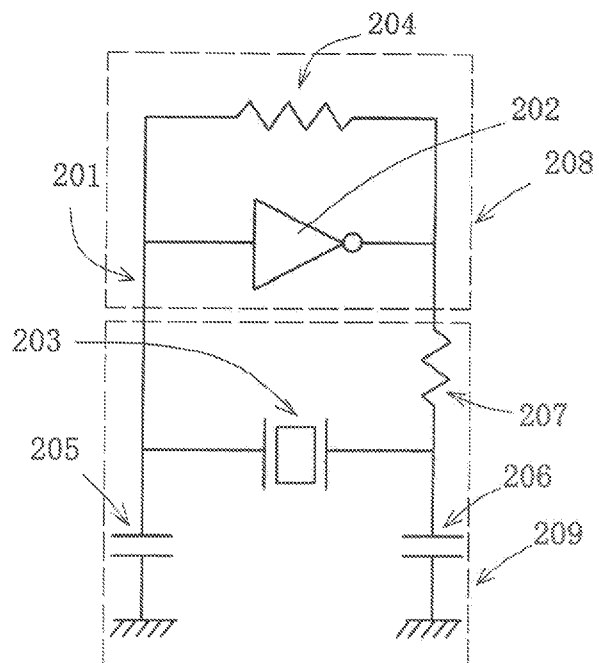

FIG. 22

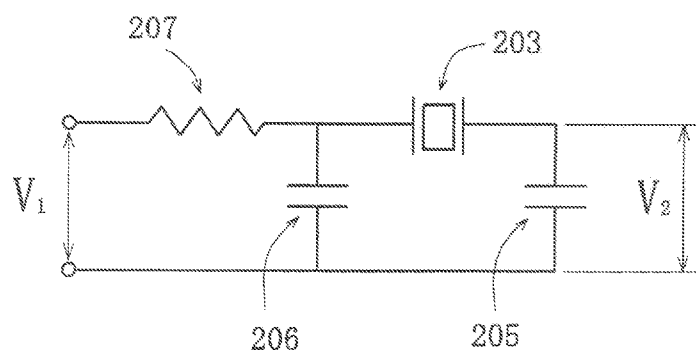
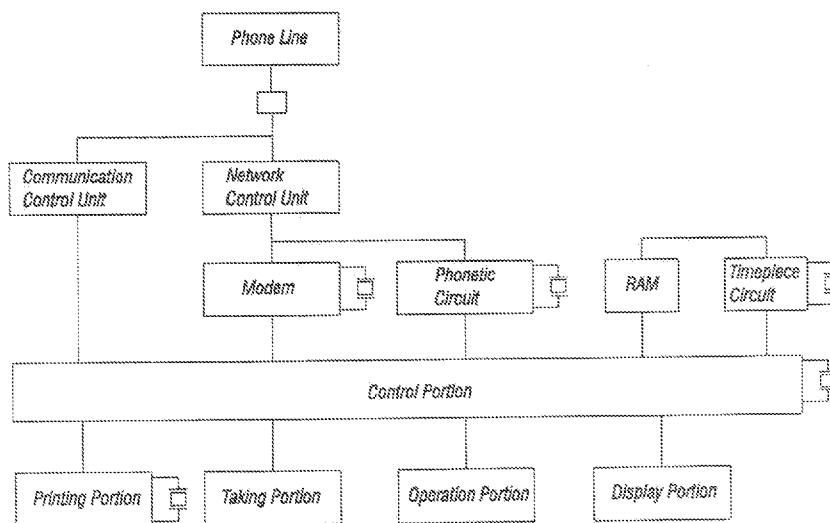

FIG. 23





## QUARTZ CRYSTAL UNIT, QUARTZ CRYSTAL OSCILLATOR AND ELECTRONIC APPARATUS

### FIELD OF THE INVENTION

[0001] The present invention relates to a resonator, a unit having the resonator, an oscillator having the unit and an electronic apparatus having the oscillator, and their manufacturing methods.

### BACKGROUND OF THE INVENTION

[0002] There are many electronic apparatuses comprising a display portion and a quartz crystal oscillator at least. For example, cellular phones, wristwatches, facsimiles, digital cameras and DVD recorders comprising a quartz crystal oscillator are well known. Recently, because of high stability for frequency, miniaturization and the light weight nature of these electronic apparatuses, the need for an electronic apparatus comprising a smaller quartz crystal oscillator with a frequency of high stability has arisen. For example, the quartz crystal oscillator having a quartz crystal tuning fork resonator housed in a unit, which vibrates in a flexural mode, is widely used as a time standard in an electronic apparatus such as the cellular phones, the wristwatches, the facsimiles, the digital cameras and the DVD recorders.

[0003] Similar to this, the same need has also arisen for an electronic apparatus comprising a contour mode resonator such as a length-extensional mode quartz crystal resonator, a width-extensional mode quartz crystal resonator and a Lame mode quartz crystal resonator or a thickness shear mode quartz crystal resonator or a SAW (Surface Acoustic Wave) resonator or a resonator for sensing angular velocity made of a piezoelectric material such as quartz crystal, lithium tantalate ( $\text{LiTaO}_3$ ), lithium niobate ( $\text{LiNbO}_3$ ) and ceramics.

[0004] Heretofore, however, it has been impossible to obtain an electronic apparatus comprising a smaller quartz crystal oscillator with a miniature quartz crystal tuning fork resonator of the prior art, capable of vibrating in a flexural mode, and having a frequency of high stability, a small series resistance and a high quality factor. This is the reason why, when miniaturized, the quartz crystal tuning fork resonator of the prior art, capable of vibrating in a flexural mode has a smaller electromechanical transformation efficiency. As a result, the resonator has a frequency of low stability, a large series resistance and a reduced quality factor.

[0005] Additionally, there has been a big problem in the quartz crystal oscillator of the prior art having the quartz crystal tuning fork resonator of the prior art, such that a frequency of a fundamental mode of vibration of the tuning fork resonator which is an output signal of the oscillator jumps to a second overtone mode of vibration thereof by shock or vibration.

[0006] Similarly, however, it has been impossible to obtain an electronic apparatus comprising a smaller quartz crystal oscillator with a contour mode resonator such as a length-extensional mode quartz crystal resonator, a width-extensional mode quartz crystal resonator and a Lame mode quartz crystal resonator or a thickness shear mode quartz crystal resonator or a SAW resonator or a resonator for sensing angular velocity having a frequency of high stability, a small series resistance and a high quality factor because, when miniaturized, each resonator has a small electromechanical transformation efficiency, as a result, a frequency of low

stability, a large series resistance and a low quality factor, and also is not strong against shock.

[0007] It is, therefore, a general object of the present invention to provide embodiments of a quartz crystal resonator, a quartz crystal unit, a quartz crystal oscillator and an electronic apparatus of the present invention, which overcome or at least mitigate one or more of the above problems.

### SUMMARY OF THE INVENTION

[0008] The present invention relates to a resonator, a unit, an oscillator and an electronic apparatus comprising a display portion and a plurality of oscillators, one of which comprises a quartz crystal oscillator comprising a quartz crystal oscillating circuit having an amplification circuit and a feedback circuit, and also relates to their manufacturing methods, and in particular, relates to a quartz crystal resonator capable of vibrating in a flexural mode, a quartz crystal unit having the quartz crystal resonator and a quartz crystal oscillator having the quartz crystal unit and having an output signal of a frequency of high stability for a fundamental mode of vibration of the quartz crystal resonator, and also to a quartz crystal oscillator having a suppressed second overtone mode of vibration of the quartz crystal resonator, in addition, relates to a quartz crystal oscillator comprising another contour mode resonator such as a length-extensional mode resonator, a width-extensional mode resonator and a Lame mode resonator or a thickness shear mode resonator, each made of quartz crystal or a SAW resonator or a piezoelectric resonator for sensing angular velocity. The quartz crystal oscillator is, therefore, available for the electronic apparatus requiring a miniature quartz crystal oscillator with high time accuracy and shock proof.

[0009] It is an object of the present invention to provide a miniature quartz crystal resonator, capable of vibrating in a flexural mode, and having a high electromechanical transformation efficiency.

[0010] It is another object of the present invention to provide a miniature quartz crystal unit with a quartz crystal resonator, capable of vibrating in a fundamental mode of vibration of a flexural mode, and having a high electromechanical transformation efficiency.

[0011] It is a further object of the present invention to provide a quartz crystal oscillator with a miniature quartz crystal resonator, capable of vibrating in a flexural mode, and having a frequency of high stability, a small series resistance  $R_1$  and a high quality factor  $Q_1$ , whose nominal frequency for a fundamental mode of vibration is within a range of 10 kHz to 200 kHz. Especially, a frequency of about 32.768 kHz is very available for a time standard of a frequency signal.

[0012] It is still another object of the present invention to provide an electronic apparatus comprising a display portion and a plurality of oscillators.

[0013] According to one aspect of the present invention, there is provided a quartz crystal resonator comprising: a plurality of vibrational arms, each of the vibrational arms having a first main surface and a second main surface and side surfaces; and a base portion to which the vibrational arms are attached, in which the resonator has a piezoelectric constant  $e'_{12}$  in the range of  $0.1 \text{ C/m}^2$  to  $0.19 \text{ C/m}^2$  in the absolute value.

[0014] According to a second aspect of the present invention, there is provided a quartz crystal unit comprising: a quartz crystal resonator having a base portion and a plurality of vibrational arms attached to the base portion; a case for

housing the quartz crystal resonator; and a lid for covering an open end of the case, each of the vibrational arms having a first main surface and a second main surface opposite the first main surface and side surfaces, in which the quartz crystal resonator has a cutting angle in the range of ZY1 wt  $(-20^\circ$  to  $+20^\circ)/(-25^\circ$  to  $+25^\circ)/(-18^\circ$  to  $+18^\circ)$  and a piezoelectric constant  $e'_{12}$  of the resonator is within a range of  $0.1 \text{ C/m}^2$  to  $0.19 \text{ C/m}^2$  in the absolute value.

**[0015]** According to a third aspect of the present invention, there is provided a quartz crystal oscillator comprising: a quartz crystal oscillating circuit comprising: an amplification circuit comprising a CMOS inverter and a feedback resistor, and a feedback circuit comprising a quartz crystal resonator capable of vibrating in a flexural mode, a plurality of capacitors and a drain resistor, the quartz crystal resonator being housed in a package comprising a case for housing the quartz crystal resonator and a lid for covering an open end of the case, and comprising: a plurality of vibrational arms, each of the vibrational arms having a first main surface and a second main surface opposite the first main surface and side surfaces; and a base portion to which the vibrational arms are attached, in which the quartz crystal resonator has a cutting angle in the range of ZY1 wt  $(-20^\circ$  to  $+20^\circ)/(-25^\circ$  to  $+25^\circ)/(-18^\circ$  to  $+18^\circ)$  and a piezoelectric constant  $e'_{12}$  of the resonator is within a range of  $0.1 \text{ C/m}^2$  to  $0.19 \text{ C/m}^2$  in the absolute value.

**[0016]** According to a fourth aspect of the present invention, there is provided an electronic apparatus comprising a display portion and a plurality of oscillators, one of the oscillators being a quartz crystal oscillator comprising: a quartz crystal oscillating circuit comprising: an amplification circuit having a CMOS inverter and a feedback resistor, and a feedback circuit having a quartz crystal tuning fork resonator capable of vibrating in a flexural mode of an inverse phase, a plurality of capacitors and a drain resistor, the quartz crystal tuning fork resonator comprising a tuning fork base and a plurality of tuning fork arms connected to the tuning fork base, each of the tuning fork arms having a first main surface and a second main surface opposite the first main surface and side surfaces, the quartz crystal tuning fork resonator being housed in a package comprising a case for housing the resonator and a lid for covering an open end of the case, in which the quartz crystal tuning fork resonator has a fundamental mode of vibration and a second overtone mode of vibration and the amplification circuit of the quartz crystal oscillating circuit has negative resistances  $-RL_1$  and  $-RL_2$  for the fundamental mode of vibration and the second overtone mode of vibration of the quartz crystal tuning fork resonator, in which an absolute value of the negative resistances is defined by  $|-RL_1|$  and  $|-RL_2|$  and a ratio of the  $|-RL_1|$  and  $R_1$  is greater than that of the  $|-RL_2|$  and  $R_2$ , where  $R_1$  and  $R_2$  represent a series resistance of the fundamental mode of vibration and the second overtone mode of vibration of the quartz crystal resonator, respectively, in which an output signal of the quartz crystal oscillating circuit has an oscillation frequency of the fundamental mode of vibration of the quartz crystal tuning fork resonator and is a clock signal which is used to display time at a display portion of the electronic apparatus, and in which the quartz crystal tuning fork resonator has a cutting angle in the range of ZY1 wt  $(-20^\circ$  to  $+20^\circ)/(-25^\circ$  to  $+25^\circ)/(-18^\circ$  to  $+18^\circ)$  and a piezoelectric constant  $e'_{12}$  of the resonator is within a range of  $0.1 \text{ C/m}^2$  to  $0.19 \text{ C/m}^2$  in the absolute value.

**[0017]** Preferably, the piezoelectric constant  $e'_{12}$  is within a range of  $0.12 \text{ C/m}^2$  to  $0.19 \text{ C/m}^2$  in the absolute value.

**[0018]** Preferably, mounting arms protruding from the base portion comprise two.

**[0019]** Preferably, each of the vibrational arms has a groove having a first stepped portion and a second stepped portion.

**[0020]** Preferably, each of the vibrational arms has a through groove.

**[0021]** Preferably, a merit value  $M_2$  of a second overtone mode of vibration of the quartz crystal resonator having vibrational arms and a base portion is less than 30.

**[0022]** Preferably, the quartz crystal oscillator with the quartz crystal resonator is constructed so that a ratio of an amplification rate  $\alpha_1$  of the fundamental mode of vibration and an amplification rate  $\alpha_2$  of the second overtone mode of vibration of the amplification circuit is greater than that of a feedback rate  $\beta_2$  of the second overtone mode of vibration and a feedback rate  $\beta_1$  of the fundamental mode of vibration of the feedback circuit, and a product of the amplification rate  $\alpha_1$  and the feedback rate  $\beta_1$  of the fundamental mode of vibration is greater than 1.

**[0023]** The present invention will be more fully understood by referring to the following detailed specification and claims taken in connection with the appended drawings.

#### BRIEF DESCRIPTION OF THE DRAWINGS

**[0024]** FIG. 1 is a general view of a quartz crystal plate from which a quartz crystal resonator of the present invention is formed;

**[0025]** FIG. 2 shows a plan view of a quartz crystal resonator of a first embodiment of the present invention, and comprising a quartz crystal tuning fork resonator capable of vibrating in a flexural mode;

**[0026]** FIG. 3 shows an A-A' cross-sectional view of the vibrational arms of the quartz crystal resonator in FIG. 2;

**[0027]** FIG. 4 shows an A-A' cross-sectional view of another embodiment of the vibrational arms of the quartz crystal resonator in FIG. 2;

**[0028]** FIG. 5 shows a plan view of a quartz crystal resonator of a second embodiment of the present invention, and comprising a quartz crystal tuning fork resonator capable of vibrating in a flexural mode;

**[0029]** FIG. 6 shows a plan view of a quartz crystal resonator of a third embodiment of the present invention, and comprising a quartz crystal tuning fork resonator capable of vibrating in a flexural mode;

**[0030]** FIG. 7 shows a B-B' cross-sectional view of the vibrational arms of the resonator in FIG. 6;

**[0031]** FIG. 8 shows a plan view of a quartz crystal resonator of a fourth embodiment of the present invention, and comprising a quartz crystal tuning fork resonator capable of vibrating in a flexural mode;

**[0032]** FIG. 9 shows a plan view of a quartz crystal resonator of a fifth embodiment of the present invention, and comprising a quartz crystal tuning fork resonator capable of vibrating in a flexural mode;

**[0033]** FIG. 10 shows a plan view of a quartz crystal resonator of a sixth embodiment of the present invention, and comprising a quartz crystal tuning fork resonator capable of vibrating in a flexural mode;

**[0034]** FIG. 11 shows a plan view of a quartz crystal resonator of a seventh embodiment of the present invention, and comprising a quartz crystal tuning fork resonator capable of vibrating in a flexural mode;

**[0035]** FIG. 12 shows a plan view of a width-extensional mode quartz crystal resonator constructing an electronic apparatus of the present invention;

**[0036]** FIG. 13(a) and FIG. 13(b) show a plan view of a thickness shear mode quartz crystal resonator constructing an electronic apparatus of the present invention and a F-F' sectional view of the resonator;

**[0037]** FIG. 14 shows a plan view of a Lamé mode quartz crystal resonator constructing an electronic apparatus of the present invention;

**[0038]** FIG. 15(a) and FIG. 15(b) show a plan view of a resonator for sensing angular velocity constructing an electronic apparatus of the present invention and a G-G' sectional view of the resonator;

**[0039]** FIG. 16(a) and FIG. 16(b) show a plan view of a quartz crystal resonator of an eighth embodiment of the present invention and comprising a quartz crystal tuning fork resonator, and a J-J' sectional view of the resonator;

**[0040]** FIG. 17 shows a plan view of a quartz crystal unit of a first embodiment of the present invention and omitting a lid;

**[0041]** FIG. 18 shows a plan view of a quartz crystal unit of a second embodiment of the present invention and omitting a lid;

**[0042]** FIG. 19 shows a cross-sectional view of a quartz crystal unit of a third embodiment of the present invention;

**[0043]** FIG. 20 shows a cross-sectional view of a quartz crystal oscillator of a first embodiment of the present invention;

**[0044]** FIG. 21 shows a diagram of an embodiment of a quartz crystal oscillating circuit constructing a quartz crystal oscillator of the present invention;

**[0045]** FIG. 22 shows a diagram of the feedback circuit of FIG. 21; and

**[0046]** FIG. 23 shows a block diagram of an embodiment of an electronic apparatus of the present invention.

#### DETAILED DESCRIPTION OF THE PREFERRED EMBODIMENTS

**[0047]** Referring now to the drawings, the embodiments of the present invention will be described in more detail.

**[0048]** FIG. 1 is a general view of a quartz crystal plate 1 from which a quartz crystal resonator of the present invention is formed, and particularly, a relationship of cutting angles  $\theta_x$ ,  $\theta_y$ , and  $\theta_z$  of the quartz crystal plate 1 and its coordinate system is illustrated in FIG. 1. The coordinate system has original point o, electrical axis x, mechanical axis y and optical axis z of quartz crystal and o-xyz is constructed.

**[0049]** First, a quartz crystal plate perpendicular to z axis, so called, Z plate quartz crystal is taken. The Z plate quartz crystal has a dimension of Width  $W_0$ , length  $L_0$  and thickness  $T_0$  corresponding to a respective direction of x, y and z axes.

**[0050]** Next, this Z plate quartz crystal is, first, rotated with an angle  $\theta_y$  about the y axis, second, rotated with an angle  $\theta_x$  about x' axis which is a new axis of the x axis, and third, rotated with an angle  $\theta_z$  about z'' axis which is a new axis of the z axis. In this case, each of the x, y and z axes changes to x'', y'' and z'' axes, respectively, because each axis is rotated twice about two axes. A quartz crystal resonator of the present invention is, therefore, formed from the quartz crystal plate with the rotation angles.

**[0051]** In other words, according to an expression of IEEE notation, a cutting angle of the quartz crystal resonator of the present invention can be expressed by ZY1 wt( $\theta_y$ )/( $\theta_x$ )/( $\theta_z$ ),

and each of the angles  $\theta_y$ ,  $\theta_x$ ,  $\theta_z$  will be described later in detail according to resonators of the present invention.

**[0052]** FIG. 2 shows a plan view of a quartz crystal resonator 10 of a first embodiment of the present invention and which is a quartz crystal tuning fork resonator. The resonator 10 comprises vibrational arms 20 and 31 and a base portion 40 attached to the vibrational arms, and the base portion 40 has mounting arms 36 and 37 protruding from the base portion, each of which is mounted on a mounting portion of a package comprising a case for housing the resonator and a lid for covering an open end of the case. In addition, each of the vibrational arms 20 and 31 has a first main surface and a second main surface opposite the first main surface and side surfaces, and the vibrational arms 20 and 31 have grooves 21 and 27, respectively, each of which has stepped portions comprising a first stepped portion and a second stepped portion. Also, the resonator 10 has cutting angles  $\theta_y$ ,  $\theta_x$  and  $\theta_z$  which are within a range of  $-20^\circ$  to  $+20^\circ$ ,  $-25^\circ$  to  $+25^\circ$  and  $-18^\circ$  to  $+18^\circ$ , respectively, namely, a cutting angle of the resonator is within a range of ZY1 wt( $-20^\circ$  to  $+20^\circ$ )/( $-25^\circ$  to  $+25^\circ$ )/( $-18^\circ$  to  $+18^\circ$ ). In this embodiment, the quartz crystal tuning fork resonator can vibrate in a flexural mode of a fundamental mode of an inverse phase, and which is one of a contour mode quartz crystal resonator.

**[0053]** In more detail, the groove 21 is constructed to include a portion of a central linear line 41 of the arm 20, and the groove 27 is similarly constructed to include a portion of a central linear line 42 of the arm 31. Each of the grooves 21 and 27 has a width  $W_2$ , and the width  $W_2$  including a portion of the central linear lines 41 and 42, is preferable because a large moment of inertia occurs at the arms 20 and 31 and the arms can vibrate in a flexural mode easily. As a result, the quartz crystal tuning fork resonator capable of vibrating in a fundamental mode can be obtained with a small series resistance  $R_1$  and a high quality factor  $Q_1$ .

**[0054]** In addition, when each of the vibrational arms 20 and 31 has part widths  $W_1$  and  $W_3$ , an arm width  $W$  of the arms 20 and 31 has a relationship of  $W=W_1+W_2+W_3$ , and the part widths  $W_1$  and  $W_3$  are constructed so that  $W_1 \cong W_3$  or  $W_1 < W_3$ . In addition, the width  $W_2$  is constructed so that  $W_2 \cong W_1, W_3$ . In this embodiment, also, the grooves are constructed at the arms so that a ratio  $W_2/W$  of the width  $W_2$  and the arm width  $W$  is greater than 0.35 and less than 1, preferably, within a range of 0.35 to 0.95 and a ratio  $t_1/t$  is less than 0.79, where  $t_1$  and  $t$  are a thickness of the groove and the vibrational arms, as shown in FIG. 3, to obtain a very large moment of inertia of the vibrational arms. That is, the quartz crystal tuning fork resonator, capable of vibrating in the fundamental mode, and having a frequency of high stability can be provided with a small series resistance  $R_1$ , a high quality factor  $Q_1$ , and a small capacitance ratio  $r_1$  because it has a very large electromechanical transformation efficiency.

**[0055]** Likewise, each of the vibrational arms 20 and 31 has a length  $L$  and each of the grooves 21 and 27 has a length  $l_0$  (not shown here). In this embodiment, a ratio of the length  $l_0$  and the length  $L$  is within a range of 0.3 to 0.8 to get a quartz crystal tuning fork resonator with series resistance  $R_1$  of a fundamental mode of vibration smaller than series resistance  $R_2$  of a second overtone mode of vibration. In other words, the length  $l_0$  is within a range of 30% to 80% to the length  $L$ . In general, the length  $l_0$  is greater than 0.25 mm and less than 1.26 mm, preferably, within a range of 0.3 mm to 0.45 mm, or within a range of 0.45 mm to 1.25 mm, more preferably, within a range of 0.45 mm to 0.51 mm. Also, when a plurality

of grooves are formed in at least one of upper and lower faces of the arms and divided in the length direction of the arms, the length  $l_0$  is a total length of the grooves.

[0056] In addition, electrodes **25** and **26** are disposed on side surfaces of the vibrational arm **20** and an electrode **23** is disposed on a surface of the groove **21**, which extends on a surface of the mounting arm **36** having a connecting portion **34**. Similar to this, electrodes **32** and **33** are disposed on side surfaces of the vibrational arm **31** and an electrode **29** is disposed on a surface of the groove **27**, which extends on a surface of the mounting arm **37** having a connecting portion **35**. Each of the connecting portions **34** and **35** has a length  $L_2$  and a width  $W_5$ , and each of the mounting arms has a length  $L_3$  and a width  $W_6$ . Also, the electrode **23** is connected to the electrodes **32** and **33**, and the electrode **29** is connected to the electrodes **25** and **26**.

[0057] In this embodiment, the length  $l_0$  of the groove corresponds to a length  $l_d$  of the electrode disposed inside each of the grooves, when the length  $l_d$  of the electrode is less than the length  $l_0$  of the groove, namely, the length  $l_0$  is of the length  $l_d$  of the electrode. In addition, the base portion **40** has a length  $L_1$  and a width  $W_H$ , the length  $L_1$  is less than 0.5 mm, preferably, within a range of 0.015 mm to 0.49 mm, more preferably, within a range of 0.015 mm to 0.205 mm or within a range of 0.12 mm to 0.45 mm, and an overall length  $L_t$  ( $=L+L_1$ ) in this embodiment is less than 2.1 mm, preferably, within a range of 0.8 mm to 1.95 mm, more preferably, within a range of 1.02 mm to 1.95 mm to obtain a miniature quartz crystal resonator. Also, when a spaced-apart distance  $W_4$  between the vibrational arms is taken, a total width  $W_5$  ( $=2W+W_4$ ) is less than 0.53 mm, preferably, within a range of 0.15 mm to 0.52 mm, and the width  $W_5$  is equal to or less than the  $W_H$  which is less than 0.55 mm, preferably, within a range of 0.15 mm to 0.53 mm.

[0058] In addition, the length  $L_3$  is greater than or equal to the length  $L_2$  and also, the length  $L_1$  is greater than or equal to the length  $L_2$  or the length  $L_1$  is less than the length  $L_2$ . In actual, a value of  $L_1-L_2$  is within a range of -0.1 mm to 0.32 mm, preferably, within a range of -0.1 mm to 0.195 mm or within a range of 0 mm to 0.3 mm, more preferably, 0 mm, namely,  $L_1=L_2$ , especially, when  $W_H$  is greater than  $W_5$ , a distance  $L_4$  between an edge of the connecting portion and an outer edge of the vibrational arm is within a range of 0.012 mm to 0.38 mm. In addition, the base portion **40** has a plurality of cut portions having a first cut portion (not shown here) and a second cut portion (not shown here), each of the first and second cut portions is cut into the base portion **40** from a side surface having the distance  $L_4$  between the edge of the connecting portion and the outer edge of the vibrational arm. Namely, the first cut portion is cut into the base portion **40** from the side surface having the distance  $L_4$  between the edge of the connecting portion **34** and the outer edge of the vibrational arm **20** and the second cut portion is cut into the base portion **40** from the side surface having the distance  $L_4$  between the edge of the connecting portion **35** and the outer edge of the vibrational arm **31**. In more detail, the base portion **40** has a first side surface and a second side surface opposite the first side surface, the first cut portion is cut into the base portion **40** from an arbitrary position of the first side surface of the base portion **40** and the second cut portion is cut into the base portion **40** from an arbitrary position of the second side surface of the base portion **40**, preferably, the first cut portion and the second cut portion are formed symmetrical to an central linear line (portion) of the base portion **40**. Namely,

the first cut portion is formed opposite the second cut portion in the width direction of the base portion **40**. It is needless to say that the vibrational arms **20**, **31** are connected to a side surface of the base portion **40** different from each of the first and second side surfaces of the base portion **40**. In other words, the base portion **40** has first and second base portions each including the width  $W_H$  and two cut portions having the first and second cut portions are formed between the first and second base portions of the base portion **40**. In addition, each of the vibrational arms **20**, **31** is connected to the first base portion of the base portion **40** and each of the connecting portions **34**, is connected to the second base portion of the base portion **40**. Namely, a third base portion having a width less than the width  $W_H$  of each of the first and second base portion of the base portion **40** is formed between the first and second base portions thereof. Also, the width  $W_6$  is less than 0.45 mm, preferably, within a range of 0.08 mm to 0.4 mm, In addition, the width  $W_6$  is greater than the width  $W$  of the vibrational arms **20**, **31**, and the width  $W_6$  is, preferably, within a range of 1.1 times of the width  $W$  to 3.8 times of the width  $W$  to get the quartz crystal tuning fork resonator with the enough resistance against a shock, and the length  $L_3$  is less than 2.1 mm, preferably, within a range of 0.3 mm to 1.85 mm to reduce a leakage energy by vibration, and also, the width  $W_5$  is less than 0.41 mm, preferably, within a range of 0.015 mm to 0.14 mm, and the length  $L_2$  is greater than 0.025 mm and less than 0.55 mm, preferably, within a range of 0.04 mm to 0.5 mm to get a shock proof quartz crystal resonator having a reduced leakage energy by vibration. In addition, the length  $L_2$  is less than the width  $W_6$  to get the shock proof quartz crystal resonator having the reduced leakage energy by vibration.

[0059] Moreover, the distance  $W_4$  and the width  $W_2$  are constructed so that  $W_4 \cong W_2$ , and more, the distance  $W_4$  is within a range of 0.045 mm to 0.65 mm and the width  $W_2$  is within a range of 0.02 mm to 0.12 mm, preferably, within a range of 0.02 mm to 0.04 mm, more preferably, within a range of 0.02 mm to 0.035 mm because it is easy to form a very small-sized resonator shape and grooves formed at the vibrational arms separately by a photo-lithographic process and an etching process, consequently, a frequency stability for a fundamental mode of vibration of the resonator gets higher than that for a second overtone mode of vibration thereof. In this embodiment, a quartz wafer having a thickness  $t$  of 0.045 mm to 0.35 mm is used.

[0060] For example, in order to get a smaller-sized quartz crystal tuning fork resonator, capable of vibrating in a flexural mode, it is necessary that the width  $W_2$  of the groove is less than 0.07 mm and the arm width  $W$  is less than 0.18 mm, and preferably, the  $W$  is greater than 0.05 mm and less than 0.1 mm. Also, the thickness  $t_1$  of the groove is within a range of 0.01 mm to 0.085 mm approximately, and the part widths  $W_1$  and  $W_3$  are less than 0.021 mm, respectively, preferably, less than 0.015 mm and greater than  $2 \times 10^{-4}$  mm or within a range of  $2 \times 10^{-4}$  to  $5 \times 10^{-4}$ , more preferably, greater than  $5 \times 10^{-4}$  mm and less than  $3 \times 10^{-3}$  mm or within a range of 0.003 mm to 0.012 mm. As a result, the small-sized quartz crystal tuning fork resonator is obtained with a small capacitance ratio  $r_1$  and a small series resistance  $R_1$  of a fundamental mode of vibration because even when miniaturized the quartz crystal resonator has very large electromechanical transformation efficiency. In addition, a groove provided on at least one of an

obverse face and a reverse face of the vibrational arms of this embodiment may be a through hole, namely, the thickness of the hole  $t_1=0$ .

**[0061]** In more detail, to obtain a quartz crystal tuning fork resonator, capable of vibrating in a flexural mode, and having a frequency of high stability which achieves high time accuracy, it is necessary to obtain the resonator whose resonance frequency is not influenced by shunt capacitance because quartz crystal is a piezoelectric material and the stability for frequency is very dependent on the shunt capacitance. In order to decrease the influence on the resonance frequency by the shunt capacitance, a merit value  $M_i$  plays an important role. Namely, the merit value  $M_i$  that expresses inductive characteristics, an electromechanical transformation efficiency and a quality factor of a quartz crystal tuning fork resonator, is defined by a ratio  $Q_i/r_i$  of a quality factor  $Q_i$  and capacitance ratio  $r_i$ , namely,  $M_i$  is given by  $M_i=Q_i/r_i$ , where  $i$  shows a vibration order of the resonator, and for example, when  $i=1$  and  $2$ , merit values  $M_1$  and  $M_2$  are for a fundamental mode of vibration of the resonator and a second overtone mode of vibration thereof, respectively.

**[0062]** Also, a frequency difference  $\Delta f$  of resonance frequency  $f_s$  of mechanical series independent on the shunt capacitance and resonance frequency  $f_r$  dependent on the shunt capacitance is inversely proportional to the merit value  $M_i$ . The larger the value  $M_i$  becomes, the smaller the difference  $\Delta f$  becomes. Namely, the influence on the resonance frequency  $f_r$  by the shunt capacitance decreases because it is close to the resonance frequency  $f_s$ . Accordingly, the larger the  $M_i$  becomes, the higher the stability for frequency of the quartz crystal tuning fork resonator becomes because the resonance frequency  $f_r$  of the resonator is almost never dependent on the shunt capacitance. Namely, the quartz crystal tuning fork resonator can be provided with a high time accuracy.

**[0063]** In detail, the quartz crystal tuning fork resonator can be obtained with the merit value  $M_1$  of the fundamental mode of vibration greater than the merit value  $M_2$  of the second overtone mode of vibration by providing the above-described tuning fork shape, grooves and dimensions. That is to say, a relationship of  $M_1>M_2$  is obtained. As an example, when a resonance frequency of a quartz crystal tuning fork resonator capable of vibrating in a flexural mode is about 32.768 kHz for a fundamental mode of vibration and the resonator has a value of  $W_2/W=0.5$ ,  $t_1/t=0.34$  and  $l_1/l=0.48$ , though there is a distribution in production, the resonator has a merit value of  $M_1>65$  for the fundamental mode of vibration and a merit value of  $M_2<30$  for the second overtone mode of vibration, respectively.

**[0064]** Namely, the quartz crystal tuning fork resonator can be provided with high inductive characteristics, good electro-mechanical transformation efficiency (small capacitance ratio  $r_1$  and small series resistance  $R_1$ ) and a high quality factor. As a result, a stability for frequency of the fundamental mode of vibration becomes higher than that of the second overtone mode of vibration, and simultaneously, the second overtone mode of vibration can be suppressed because capacitance ratio  $r_2$  and series resistance  $R_2$  of the second overtone mode of vibration become greater than capacitance ratio  $r_1$  and series resistance  $R_1$  of the fundamental mode of vibration, respectively. In particular,  $r_2$  has a value greater than 1500 in this embodiment. In order to ensure the suppression of the second overtone mode of vibration,  $r_2$  is, preferably, greater than 1800, more preferably, greater than 2000.

**[0065]** Therefore, the resonator capable of vibrating in the fundamental mode vibration can be provided with a high time accuracy because it has the frequency of high stability. Consequently, a quartz crystal oscillator comprising the quartz crystal tuning fork resonator of this embodiment outputs an oscillation frequency of the fundamental mode vibration as an output signal, and the frequency of the output signal has a very high stability, namely, excellent time accuracy. In other words, the quartz crystal oscillator of this embodiment has a remarkable effect such that a frequency change by ageing becomes extremely small. Also, an oscillation frequency of the quartz crystal resonator of this embodiment is adjusted so that a frequency deviation is within a range of  $-100$  PPM to  $+100$  PPM to a nominal frequency, e.g. 32.768 kHz, after mounting it on a mounting portion of a case for housing the resonator.

**[0066]** In addition, the groove thickness  $t_1$ , shown in FIG. 3, of the present invention is the thinnest thickness of the grooves because quartz crystal is an anisotropic material and the groove thickness  $t_1$  has a distribution when it is formed by a chemical etching method. In detail, a groove shape of the sectional view of vibrational arms in FIG. 3 has a rectangular shape, but the groove shape has an about U shape actually. In the above-described embodiments, though the grooves are constructed at the arms, this invention is not limited to this, namely, a relationship of the merit values  $M_1$  and  $M_2$  can be applied to the conventional quartz crystal tuning fork resonator and a relationship of a quartz crystal oscillating circuit comprising an amplification circuit and a feedback circuit can be also applied to the conventional quartz crystal tuning fork resonator to suppress a second overtone mode vibration and to get a high frequency stability for a fundamental mode of vibration of the quartz crystal tuning fork resonator. In addition, the length  $L_3$  of each of the mounting arms 36, 37 is greater than the length  $L_1$  of the base portion 40 and less than the overall length  $L_r (=L+L_r)$  of the quartz crystal resonator 10, as is apparent from FIG. 2.

**[0067]** FIG. 3 shows an A-A' cross-sectional view of the vibrational arms 20 and 31 of the quartz crystal resonator 10 in FIG. 2, and electrode construction within the grooves. The vibrational arm 20 has grooves 21 and 22 cut into it, which include a portion of central linear line of the arm 20. The grooves 21 and 22 have a first set of electrodes 23 and 24 of the same electrical polarity, while the side surfaces of the arm 20 have a second set of electrodes 25 and 26 having an opposite electrical polarity to the first set of electrodes 23 and 24. The vibrational arm 31 has grooves 27 and 28 constructed in a similar manner as the vibrational arm 20. The grooves 27 and 28 have a third set of electrodes 29 and 30 of the same electrical polarity, and the side surfaces of the vibrational arm 31 have a fourth set of electrodes 32 and 33 with the opposite electrical polarity to the third electrodes 29 and 30. The electrodes disposed on the vibrational arms 20 and 31 are connected as shown in FIG. 3, namely, two electrode terminals of different electrical polarity C-C' are obtained.

**[0068]** In detail, the first set of electrodes 23 and 24 disposed on the grooves 21 and 22 of the vibrational arm 20 have the same electrical polarity as the fourth set of electrodes 32 and 33 disposed on both side surfaces of the vibrational arm 31, while the second set of electrodes 25 and 26 disposed on both side surfaces of the vibrational arm 20 have the same electrical polarity as the third set of electrodes 29 and 30 disposed on the grooves 27 and 28 of the arm 31. When a direct voltage is applied between the electrode terminals

C-C', an electric field  $E_x$  occurs along the arrow direction inside the vibrational arms **20** and **31**. As the electric field  $E_x$  occurs perpendicular to the electrodes disposed on the vibrational arms, as shown in the arrow signs, the electric field  $E_x$  has a very large value and a large distortion occurs at the vibrational arms. As a result, a quartz crystal tuning fork resonator capable of vibrating in a flexural mode is obtained with a small series resistance  $R_1$  and a high quality factor  $Q$  because even when miniaturized there is a very large electro-mechanical transformation efficiency for the resonator.

[0069] FIG. 4 shows an A-A' cross-sectional view of another embodiment of the vibrational arms **20** and **31** of the quartz crystal resonator **10** in FIG. 2. The vibrational arm **20** has a through groove **21a**, which include a portion of central linear line of the arm **20**. The through groove **21a** has a first set of electrodes **23a** and **24a** of the same electrical polarity, while the side surfaces of the arm **20** have a second set of electrodes **25** and **26** having an opposite electrical polarity to the first set of electrodes **23a** and **24a**. The vibrational arm **31** has a through groove **27a** constructed in a similar manner as the vibrational arm **20**. The through groove **27a** has a third set of electrodes **29a** and **30a** of the same electrical polarity, and the side surfaces of the vibrational arm **31** have a fourth set of electrodes **32** and **33** with the opposite electrical polarity to the third electrodes **29a** and **30a**. The electrodes disposed on the vibrational arms **20** and **31** are connected as shown in FIG. 4, namely, two electrode terminals of different electrical polarity E-E' are obtained.

[0070] In detail, the first set of electrodes **23a** and **24a** disposed on the through groove **21a** of the vibrational arm **20** have the same electrical polarity as the fourth set of electrodes **32** and **33** disposed on both side surfaces of the vibrational arm **31**, while the second set of electrodes **25** and **26** disposed on both side surfaces of the vibrational arm **20** have the same electrical polarity as the third set of electrodes **29a** and **30a** disposed on the through groove **27a** of the arm **31**. When a direct voltage is applied between the electrode terminals E-E', an electric field  $E_x$  occurs along the arrow direction inside the vibrational arms **20** and **31**. As the electric field  $E_x$  occurs perpendicular to the electrodes disposed on the vibrational arms, as shown in the arrow signs, the electric field  $E_x$  has a very large value and a large distortion occurs at the vibrational arms. As a result, a quartz crystal tuning fork resonator capable of vibrating in a flexural mode is obtained with a small series resistance  $R_1$  and a high quality factor  $Q$  because even when miniaturized there is a very large electromechanical transformation efficiency for the resonator.

[0071] FIG. 5 shows a plan view of a quartz crystal resonator **50** of a second embodiment of the present invention, and which is a quartz crystal tuning fork resonator capable of vibrating in a flexural mode. The resonator **50** comprises vibrational arms **60** and **71** and a base portion **80** attached to the vibrational arms, and the base portion **80** has a mounting arm **77** protruding from the base portion, and the mounting arm **77** is mounted on a mounting portion of a package comprising a case for housing the resonator and a lid for covering an open end of the case. In addition, each of the vibrational arms **60** and **71** has a first main surface and a second main surface and side surfaces, and the vibrational arms **60** and **71** have grooves **61** and **67**, respectively, each of which has stepped portions comprising a first stepped portion and a second stepped portion. Also, the resonator **50** has the same

cutting angles  $\theta_y$ ,  $\theta_x$  and  $\theta_z$  and the same dimensions  $W_1$ ,  $W_2$ ,  $W_3$ ,  $W_4$ ,  $W_5$ ,  $W$ ,  $L_1$ ,  $L_2$ ,  $L_3$ ,  $L_4$  and  $L$  as the resonator of FIG. 2.

[0072] In more detail, the groove **61** is constructed to include a portion of a central linear line **81** of the arm **60**, and the groove **67** is similarly constructed to include a portion of a central linear line **82** of the arm **71**. Each of the grooves **61** and **67** has a width  $W_2$ , and the width  $W_2$  includes a portion of the central linear lines **81** and **82** because a large moment of inertia occurs at the arms **60** and **71**. In this embodiment, the resonator is a quartz crystal tuning fork resonator capable of vibrating in a flexural mode and which can vibrate in a fundamental mode of an inverse phase easily. As a result, the quartz crystal tuning fork resonator capable of vibrating in a fundamental mode of an inverse phase can be obtained with a small series resistance  $R_1$  and a high quality factor  $Q_1$ .

[0073] In addition, electrodes **65** and **66** are disposed on side surfaces of the vibrational arm **60** and an electrode **63** is disposed on a surface of the groove **61**, and which is connected to electrodes **72** and **73** disposed on side surfaces of the vibrational arm **71**. Also, the electrode **63** is connected to an electrode disposed on a surface of the mounting arm **77** through an electrode disposed on a surface of the connecting portion **75**. Similar to this, an electrode **69** is disposed on a surface of the groove **67**, which extends on a surface of the mounting arm **77** having a first mounting arm portion including a first width  $W_6$  and a second mounting arm portion including a second width greater than the first width  $W_6$ , and a connecting portion **75**. Also, the electrode **69** is connected to the electrodes **65** and **66** and is connected to an electrode disposed on a surface of each of the first and second mounting arm portions of the mounting arm **77** through an electrode disposed on a surface of the connecting portion **75**.

[0074] FIG. 6 shows a plan view of a quartz crystal resonator **90** of a third embodiment of the present invention, which is a quartz crystal tuning fork resonator capable of vibrating in a flexural mode. The resonator **90** comprises vibrational arms **91** and **92** and a base portion **95** attached to the vibrational arms, and the base portion **90** has a mounting arm **96** protruding from the base portion. In this embodiment, the mounting arm **96** is between the vibrational arms **91** and **92** and is mounted on a mounting portion of a package comprising a case for housing the resonator and a lid for covering an open end of the case. In addition, each of the vibrational arms **91** and **92** has a first main surface and a second main surface opposite the first main surface and side surfaces, and the vibrational arms **91** and **92** have grooves **93** and **94**, respectively, each of which has stepped portions comprising a first stepped portion and a second stepped portion. Also, the resonator **90** has the same cutting angles  $\theta_y$ ,  $\theta_x$  and  $\theta_z$  as the quartz crystal resonator **10** of FIG. 2. In this embodiment, the quartz crystal tuning fork resonator can vibrate in a flexural mode of a fundamental mode of an inverse phase.

[0075] In detail, similar to the resonator of FIG. 2, the groove **93** is also constructed to include a portion of a central linear line of the arm **91**, and also, the groove **94** is similarly constructed to include a portion of a central linear line of the arm **92**. Each of the grooves **93** and **94** has a width  $W_2$ , and the width  $W_2$  includes a portion of the central linear lines because a large moment of inertia occurs at the vibrational arms **91** and **92** and which can vibrate in a flexural mode easily. As a result, the quartz crystal tuning fork resonator capable of vibrating in a fundamental mode can be obtained with a small series resistance  $R_1$  and a high quality factor  $Q_1$ .

[0076] In addition, the base portion **95** has a length  $L_1$  and a width  $W_H$ . Also, each of the vibrational arms **91** and **92** has a width  $W$ , part widths  $W_1$  and  $W_3$  and a width  $W_2$  of the groove, namely, there is a relationship of  $W=W_1+W_2+W_3$ . In detail, the resonator **90** has the same dimensions  $L_1$ ,  $W_H$ ,  $W_1$ ,  $W_2$ ,  $W_3$ , and  $W$  and the same relationship as the resonator **10** of FIG. 2. Moreover, the mounting arm **96** has a width  $W_{11}$  and there is a distance  $W_{10}$  between the vibrational arm **91** or the vibrational arm **92** and the mounting arm **96**. In order to get a quartz crystal tuning fork resonator with reduced leakage energy by vibration of the vibrational arms, the distance  $W_{10}$  is within a range of 0.032 mm to 0.21 mm and the width  $W_{11}$  is within a range of 0.21 mm to 0.88 mm. In addition, to get a shockproof quartz crystal tuning fork resonator,  $W_{11}$  has a relationship of  $(1.2 \text{ to } 7.6) \times W$ . In this embodiment, a total width  $W_A (=2W + 2W_{10} + W_{11})$  is less than 1.3 mm, preferably, within a range of 0.52 mm to 1.2 mm, to get a miniature quartz crystal, tuning fork resonator.

[0077] FIG. 7 shows a B-B' cross-sectional view of the vibrational arms **91** and **92** of the resonator **90** in FIG. 6. The vibrational arm **91** has grooves **93** and **97** cut into it, and the grooves **93** and **97** have a first set of electrodes **100** and **101** of the same electrical polarity, while the side surfaces of the arm **91** have a second set of electrodes **99** and **102** having an opposite electrical polarity to the first set of electrodes **100** and **101**. The vibrational arm **92** has grooves **94** and **98** constructed in a similar manner as the vibrational arm **91**. The grooves **94** and **98** have a third set of electrodes **106** and **107** of the same electrical polarity, and the side surfaces of the vibrational arm **92** have a fourth set of electrodes **105** and **108** with the opposite electrical polarity to the third electrodes **106** and **107**. The electrodes disposed on the vibrational arms **91** and **92** are connected as shown in FIG. 7, namely, two electrode terminals of different electrical polarity D-D' are obtained.

[0078] In detail, the first set of electrodes **100** and **101** disposed on the grooves **93** and **97** of the vibrational arm **91** have the same electrical polarity as the fourth set of electrodes **105** and **108** disposed on both side surfaces of the vibrational arm **92** and an electrode **104** disposed on the mounting arm **96**, while the second set of electrodes **99** and **102** disposed on both side surfaces of the vibrational arm **91** have the same electrical polarity as the third set of electrodes **106** and **107** disposed on the grooves **94** and **98** of the arm **92** and an electrode **103** disposed on the mounting arm **96**. When a direct voltage is applied between the electrode terminals D-D', an electric field  $E_x$  occurs along the arrow direction inside the vibrational arms **91** and **92**. As the electric field  $E_x$  occurs perpendicular to the electrodes disposed on the vibrational arms, as shown in the arrow signs, the electric field  $E_x$  has a very large value and a large distortion occurs at the vibrational arms. Consequently, a quartz crystal tuning fork resonator capable of vibrating in a flexural mode is obtained with a small series resistance  $R_1$  and a high quality factor  $Q$  because even when miniaturized, there is very large electro-mechanical transformation efficiency for the resonator.

[0079] FIG. 8 shows a plan view of a quartz crystal resonator **110** of a fourth embodiment of the present invention, which is a quartz crystal tuning fork resonator. The resonator **110** comprises vibrational arms **111** and **112** and a base portion **113** attached to the vibrational arms, and the base portion **113** has mounting arms **114** and **115** protruding from the base portion, each of which is mounted on a mounting portion of a package comprising a case for housing the resonator and a lid

for covering an open end of the case. In this embodiment, the vibrational arms **111** and **112** have grooves **116** and **117**, respectively. In more detail, each of the vibrational arms **111** and **112** has an end portion connected to the base portion and a free end portion, when a distance measured from the end portion to the free end portion is a length  $L$ , each of the vibrational arms has a width  $W$  between the end portion and half a length  $L/2$  of each of the vibrational arms and a width  $W_e$  between half the length  $L/2$  and the length  $L$  of the free end portion of each of the vibrational arms, and the width  $W$  is less than the width  $W_e$ . In this embodiment, the quartz crystal tuning fork resonator can vibrate in a flexural mode and vibrate in a fundamental mode of an inverse phase.

[0080] Similar to this, a quartz crystal tuning fork resonator **120** of a fifth embodiment of the present invention is shown in FIG. 9 showing a plan view thereof. The resonator **120** comprises vibrational arms **121** and **122** and a base portion **123** attached to the vibrational arms, and the base portion **123** has a mounting arm **124** protruding from the base portion. In this embodiment, the mounting arm **124** is between the vibrational arms **121** and **122** and the vibrational arms **121** and **122** have grooves **125** and **126**, respectively. For this case the width  $W$  is also less than the width  $W_e$  similar to that of FIG. 8.

[0081] FIG. 10 shows a plan view of a quartz crystal resonator **130** of a sixth embodiment of the present invention, which is a quartz crystal tuning fork resonator. The resonator **130** comprises vibrational arms **131** and **132** and a base portion **133** attached to the vibrational arms, and the base portion **133** has mounting arms **134** and **135** protruding from the base portion, each of which is mounted on a mounting portion of a package comprising a case for housing the resonator and a lid for covering an open end of the case. In this embodiment, the vibrational arms **131** and **132** have grooves **136** and **137**, respectively. In more detail, each of the vibrational arms **131** and **132** has an end portion connected to the base portion and a free end portion, when a distance measured from the end portion to the free end portion is a length  $L$ , each of the vibrational arms has a width  $W$  between the end portion and half a length  $L/2$  of each of the vibrational arms and a width  $W_e$  between half the length  $L/2$  and the length  $L$  of the free end portion of each of the vibrational arms, and the width  $W$  is less than the width  $W_e$ . In this embodiment, the quartz crystal tuning fork resonator can vibrate in a flexural mode and vibrate in a fundamental mode of an inverse phase. As above-described, each of the vibrational arms has the width  $W$  and the width  $W_e$  greater than the width  $W$  in this embodiment, but, this invention is not limited to this, namely, each of the vibrational arms may comprise a plurality of different thicknesses having a first thickness  $T$  and a second thickness  $T_e$  greater than the first thickness  $T$ . In other words, each of the vibrational arms comprises a first vibrational portion having the first thickness  $T$  and a second vibrational portion having the second thickness  $T_e$  greater than the first thickness  $T$ . Namely, the width  $W$  is replaced with the thickness  $T$  and the width  $W_e$  is replaced with the thickness  $L$ . This invention may include the relationships of the thickness  $T_e$  greater than the thickness  $T$  and the width  $W_e$  greater than the width  $W$ . As is shown in FIG. 10, at least one groove is formed in each of upper and lower faces of the first vibrational portion of each of the vibrating arms. In addition, the second vibrational portion having the width  $W_e$  and/or the thickness  $T_e$  has opposite main surfaces and opposite side surfaces, e.g. the opposite main surfaces has a third main surface and a fourth main

surface and the opposite side surfaces has a third side surface and a fourth side surface, and e.g. a plurality of metal films comprising a first metal film having a first thickness and a second metal film having a second thickness greater than the first thickness are disposed on at least one or each of the third and fourth main surfaces of the second vibrational portion of each of the vibrational arms, and the first thickness of the first metal film is less than a half of the second thickness of the second metal film, preferably, one third of the second thickness of the second metal film. Also, at least one of the first and second metal films disposed on at least one of the third and fourth main surfaces of the second vibrational portion of each of the vibrational arms extends on at least one or each of the third and fourth side surfaces of the second vibrational portion of the corresponding one of the vibrational arms and at least one of the first and second metal films comprises gold or silver. For another instance, the second vibrational portion of each of the vibrational arms has a third main surface and a fourth main surface opposite the third main surface and each of the third and fourth main surfaces has a first main portion and a second main portion. In addition, a first metal film is disposed on each of the first and second main portions of at least one of the third and fourth main surfaces of the second vibrational portion of each of the vibrational arms and a second metal film is disposed on the first metal film disposed on each of the first and second main portions of the at least one of the third and fourth main surfaces of the second vibrational portion of each of the vibrational arms. Also, a thickness of the second metal film on the first metal film disposed on the second main portion of the at least one of the third and fourth main surfaces of the second vibrational portion of each of the vibrational arms is greater than a thickness of the second metal film on the first metal film disposed on the first main portion of the at least one of the third and fourth main surfaces of the second vibrational portion of the corresponding one of the vibrational arms, and the second metal film is disposed on the first metal film disposed on the second main portion of the at least one of the third and fourth main surfaces of the second vibrational portion of each of the vibrational arms so that the quartz crystal tuning fork resonator has an oscillation frequency lower than 32.75 kHz. In addition, a thickness of the first metal film disposed on the first main portion of the at least one of the third and fourth main surfaces of the second vibrational portion of each of the vibrational arms is substantially equal to a thickness of the first metal film disposed on the second main portion of the at least one of the third and fourth main surfaces of the second vibrational portion of the corresponding one of the vibrational arms and the first metal film comprises chromium or nickel. For further instance, the second vibrational portion of each of the vibrational arms has a third side surface and a fourth side surface opposite the third side surface, and a fifth side surface free in vibration. The third side surface is connected to the fourth side surface through the fifth side surface, and a third electrode is disposed on the third side surface, a fourth electrode is disposed on the fourth side surface and a fifth electrode is disposed on the fifth side surface, the third electrode disposed on the third side surface is connected to the fourth electrode disposed on the fourth side surface through the fifth electrode disposed on the fifth side surface to prevent the resonator from chipping end portions of the vibrational arms thereof when shocked.

**[0082]** Similar to this, a quartz crystal tuning fork resonator **140** of a seventh embodiment of the present invention is shown in FIG. 11 showing a plan view thereof. The resonator

**140** comprises vibrational arms **141** and **142** and a base portion **143** attached to the vibrational arms, and the base portion **143** has a mounting arm **144** protruding from the base portion. In this embodiment, the mounting arm **144** is between the vibrational arms **141** and **142** and the vibrational arms **141** and **142** have grooves **145** and **146**, respectively. For this case the width  $W$  is also less than the width  $W_e$  similar to that of FIG. 10.

**[0083]** Especially, the quartz crystal tuning fork resonator of the fourth embodiment to the seventh embodiment can be miniaturized with a small series resistance  $R_1$  and a high quality factor  $Q_1$  because it has a width  $W_e$  greater than a width  $W$ , and the width  $W_e$  operates as a mass.

**[0084]** Next, a value of a piezoelectric constant  $e'_{12}$  is described, which is of great importance and necessary to excite a quartz crystal tuning fork resonator capable of vibrating in a flexural mode of the present invention. The larger a value of the piezoelectric constant  $e'_{12}$  becomes, the higher electromechanical transformation efficiency becomes. The piezoelectric constant  $e'_{12}$  of the present invention can be defined by a function of the cutting angles  $\theta_y$ ,  $\theta_x$  and  $\theta_z$  shown in FIG. 1, and piezoelectric constants  $e_{11}=0.171$  C/m<sup>2</sup> and  $e_{14}=-0.0406$  C/m<sup>2</sup> of quartz crystal. In order to obtain a quartz crystal tuning fork resonator, capable of vibrating in a flexural mode and having a small series resistance  $R_1$  and a high quality factor  $Q$ , the piezoelectric constant  $e'_{12}$  of the present invention is within a range of 0.1 C/m<sup>2</sup> to 0.19 C/m<sup>2</sup> in the absolute value. It is, therefore, easily understood that this value is enough large to obtain the quartz crystal tuning fork resonator with a small series resistance  $R_1$  and a high quality factor  $Q$ .

**[0085]** Especially, in order to obtain a quartz crystal tuning fork resonator capable of vibrating in a flexural mode with a much smaller series resistance  $R_1$ , the piezoelectric constant  $e'_{12}$  is preferably within a range of 0.12 C/m<sup>2</sup> to 0.19 C/m<sup>2</sup> in the absolute value.

**[0086]** In addition, as an example, a quartz crystal tuning fork resonator comprises a plurality of vibrational arms having a first vibrational arm and a second vibrational arm, and a groove having a first stepped portion and a second stepped portion is formed in at least one of a first main surface and a second main surface of each of the first and second vibrational arms, in which a first electrode is disposed on the first stepped portion of the groove, a second electrode is disposed on the second stepped portion of the groove, and a third electrode is disposed on each of side surfaces of each of the first and second vibrational arms, in which the piezoelectric constant  $e'_{12}(=e'_{12i})$  is between the first electrode and the third electrode disposed opposite to the first electrode, and the piezoelectric constant  $e'_{12}(=e'_{12o})$  is between the second electrode and the third electrode disposed opposite to the second electrode, and in which the piezoelectric constants  $e'_{12i}$  and  $e'_{12o}$  are within the range of 0.12 C/m<sup>2</sup> to 0.19 C/m<sup>2</sup> in the absolute value, respectively, and a product of the  $e'_{12i}$  and the  $e'_{12o}$  is greater than 0.

**[0087]** As an another example, a quartz crystal tuning fork resonator comprises a plurality of vibrational arms having a first vibrational arm and a second vibrational arm, and a through hole having a first side surface and a second side surface is formed in each of the first and second vibrational arms, in which a first electrode is disposed on the first side surface of the through hole, a second electrode is disposed on the second side surface of the through hole, and a third electrode is disposed on each of side surfaces of each of the first



and second vibrational arms, in which the piezoelectric constant  $e'_{12}(=e'_{12z})$  is between the first electrode and the third electrode disposed opposite to the first electrode, and the piezoelectric constant  $e'_{12}(=e'_{12o})$  is between the second electrode and the third electrode disposed opposite to the second electrode, and in which the piezoelectric constants  $e_{12z}$  and  $e_{12o}$  are within the range of  $0.12 \text{ C/m}^2$  to  $0.19 \text{ C/m}^2$  in the absolute value, respectively, and a product of the  $e'_{12z}$  and the  $e'_{12o}$  is greater than 0.

[0088] Therefore, the quartz crystal tuning fork resonator described above has a small series resistance  $R_1$  and a high quality factor  $Q$ , and also a frequency of high stability.

[0089] FIG. 12 shows a plan view of a width-extensional mode quartz crystal resonator 150 constructing an electronic apparatus of the present invention, and which vibrates in a width-extensional mode. The width-extensional mode resonator 150 comprises a vibrational portion 151, connecting portions 152, 152a and supporting portions 153 and 154 connected to a mounting portion 155 constructing the supporting portions. Namely, the vibrational portion 151 is connected to the supporting portions 153, 154 having the mounting portion 155 through the connecting portions 152, 152a. In addition, an electrode 151a is disposed on an obverse surface of the vibrational portion 151 and an electrode 151b (not visible) is disposed on a reverse surface of the vibrational portion 151.

[0090] In more detail, the electrode 151a disposed on the obverse surface of the vibrational portion 151 is connected to an electrode 153a disposed on the mounting portion 155, while the electrode 151b disposed on the reverse surface of the vibrational portion 151 is connected to an electrode 154a disposed on the mounting portion 155 through an electrode 154b disposed on a side surface of the mounting portion. Namely, a pair of electrodes is disposed on the obverse and reverse surfaces of the vibrational portion 151. Also, the vibrational portion 151 has a width  $W_0$  and a length  $L_0$ . In general, a ratio  $W_0/L_0$  is less than 0.35. In addition, the mounting portion 155 is mounted on a mounting portion of a package comprising a case for housing the resonator and a lid for covering an open end of the case. In this embodiment, a cutting angle of the resonator is within a range of ZY1 wt ( $80^\circ$  to  $100^\circ$ )/( $-10^\circ$  to  $+10^\circ$ )/( $75^\circ$  to  $+115^\circ$ ) and a piezoelectric constant  $e'_{31}$  of the resonator is within a range of  $0.1 \text{ C/m}^2$  to  $0.19 \text{ C/m}^2$  in the absolute value to obtain the resonator with a small series resistance  $R_1$  and a high quality factor  $Q$ .

[0091] Similar to this, a length-extensional mode quartz crystal resonator can be obtained by replacing the width  $W_0$  with the length  $L_0$ . In this case the connecting portions are formed in the width direction. In this embodiment, a cutting angle of the length-extensional mode resonator is within a range of ZY1 wt ( $80^\circ$  to  $100^\circ$ )/( $-10^\circ$  to  $+10^\circ$ )/( $-35^\circ$  to  $+35^\circ$ ) and a piezoelectric constant  $e'_{32}$  of the resonator is within a range of  $0.12 \text{ C/m}^2$  to  $0.19 \text{ C/m}^2$  in the absolute value to obtain the resonator with a small series resistance  $R_1$  and a high quality factor  $Q$ .

[0092] FIG. 13(a) and FIG. 13(b) show a plan view of a thickness shear mode quartz crystal resonator 156 constructing an electronic apparatus of the present invention and a F-F' sectional view of the thickness shear mode resonator 156 capable of vibrating in a thickness shear mode. The resonator 156 comprises a vibrational portion 157 having a width  $W_0$ , a length  $L_0$  and a thickness  $T_0$ , and electrodes 158 and 159 are disposed on an obverse surface and a reverse surface so that the electrodes have opposite electrical polarity each other.

Namely, a pair of electrodes is disposed on the vibrational portion 157. Also, the resonator 156 is housed in a package comprising a case for housing the resonator and a lid for covering an open end of the case. In this embodiment, a cutting angle of the resonator is within a range of ZY1 wt ( $-5^\circ$  to  $+5^\circ$ )/ $\pm(37^\circ$  to  $58^\circ)$ / $(85^\circ$  to  $95^\circ)$  and a piezoelectric constant  $e'_{34}$  of the resonator is within a range of  $0.055 \text{ C/m}^2$  to  $0.14 \text{ C/m}^2$  in the absolute value to obtain the resonator with a small series resistance  $R_1$  and a high quality factor  $Q$ . In order to obtain much smaller series resistance  $R_1$ , the piezoelectric constant  $e'_{34}$  of the resonator is preferably within a range of  $0.085 \text{ C/m}^2$  to  $0.12 \text{ C/m}^2$  in the absolute value.

[0093] FIG. 14 shows a plan view of a Lamé mode quartz crystal resonator 210 constructing an electronic apparatus of the present invention, and vibrating in a Lamé mode. The Lamé mode resonator 210 comprises a vibrational portion 211, connecting portions 212, 213 and supporting portions 214, 215 having mounting portions 216 and 217. Namely, the vibrational portion 211 is connected to the supporting portions 214, 215 through the connecting portions 212, 213. In addition, an electrode 218 is disposed on an obverse surface of the vibrational portion 211 and an electrode 219 (not visible) is disposed on a reverse surface of the vibrational portion 211.

[0094] In more detail, the electrode 218 disposed on the obverse surface of the vibrational portion 211 is extended into the mounting portion 217, while the electrode 219 disposed on the reverse face of the vibrational portion 211 is extended into the mounting portion 216. Namely, a pair of electrodes is disposed on the obverse and reverse surfaces of the vibrational portion 211. Also, the vibrational portion 211 has a width  $W_0$  and a length  $L_0$ . In general, a ratio  $L_0/W_0$  is approximately equal to  $m$  for a fundamental mode of vibration and an overtone mode of vibration of the resonator, where  $m$  is an order of vibration of the resonator and an integer. For example, when a Lamé mode quartz crystal resonator has one of  $m=1, 2, 3$  and  $n$ , the resonator vibrates in a fundamental mode for  $m=1$ , a second overtone mode for  $m=2$ , a third overtone mode for  $m=3$  and an  $n^{\text{th}}$  overtone mode for  $m=n$ .

[0095] Also, the  $m$  has a close relationship to the number of electrodes disposed on the vibrational portion. For example, when an electrode is disposed opposite each other on both of an obverse surface and a reverse surface of the vibrational portion, this is called "the number of two electrodes", in other words, "a pair of electrodes". Namely, the vibrational portion has the number of  $p$  electrodes, where  $p$  is an even number such as 2, 4, 6, 8 and 10. As an example, when  $p$  of the vibrational portion comprises 6, the vibrational portion vibrates in a third overtone mode. In this example, three pairs of electrodes are disposed on the vibrational portion. Namely, the third overtone mode of vibration is a principal vibration. As is apparent from this relationship, there is a relationship of  $m=p/2$ .

[0096] Therefore, the principal vibration vibrates in the order of vibration corresponding to the number of an electrode pair or electrode pairs. For example, the principal vibration vibrates in a fundamental mode of vibration, a second overtone mode of vibration and a third overtone mode of vibration, respectively, for an electrode pair, two electrode pairs and three electrode pair disposed on the vibrational portion. In detail, when  $m_e$  electrode pairs are disposed on the vibrational portion, the principal vibration vibrates in an  $n^{\text{th}}$  overtone mode of vibration, and  $m_e$  corresponds to the  $n$ , where  $m_e$  is an integer. It is needless to say that this concept

can be applied to a width-extensional mode quartz crystal resonator and a length-extensional mode quartz crystal resonator.

[0097] In more detail, an even number of electrodes are disposed on the obverse and reverse surfaces of the vibrational portion and the electrodes disposed opposite each other has an opposite electrical polarity. In addition, each of the mounting portions 216, 217 is mounted on a mounting portion of a package comprising a case for housing the resonator and a lid for covering an open end of the case. In this embodiment, a cutting angle of the resonator is within a range of ZY1 wt ( $-5^\circ$  to  $+5^\circ$ )/ $\pm(35^\circ$  to  $60^\circ)$ / $\pm(40^\circ$  to  $50^\circ)$  and a piezoelectric constant  $e'_{32}$  of the resonator is within a range of  $0.045$  C/m<sup>2</sup> to  $0.13$  C/m<sup>2</sup> in the absolute value to obtain the resonator with a small series resistance  $R_1$  and a high quality factor  $Q$ .

[0098] FIG. 15(a) and FIG. 15(b) show a plan view of a resonator for sensing angular velocity constructing an electronic apparatus of the present invention and a G-G' sectional view of the resonator. In this embodiment, the resonator 220 comprises a quartz crystal tuning fork resonator, capable of vibrating in a flexural mode and comprising vibrational arms 221, 222 and a base portion 223 attached to the vibrational arms, the base portion 223 is mounted on a mounting portion of a package comprising a case for housing the resonator and a lid for covering an open end of the case. In addition, each of the vibrational arms 221 and 222 has a first main surface and a second main surface opposite the first main surface and side surfaces, and the vibrational arm 221 has grooves 224, 230, while the vibrational arm 222 has grooves 225, 237, each of which has stepped portions comprising a first stepped portion and a second stepped portion. Also, a cutting angle of the resonator is within a range of ZY1 wt ( $-20^\circ$  to  $+20^\circ)$ / $(-25^\circ$  to  $+25^\circ)$ / $(-18^\circ$  to  $+18^\circ)$  and a piezoelectric constant  $e'_{12}$  of the resonator is within a range of  $0.1$  C/m<sup>2</sup> to  $0.19$  C/m<sup>2</sup> in the absolute value. The resonator of this embodiment can vibrate in a flexural mode of a fundamental mode and an inverse phase.

[0099] In more detail, electrodes 226 and 227 which are of the same electrical polarity are disposed on the side surfaces such that an electrode terminal H is defined, while an electrode 228 is disposed inside the groove 224 and an electrode 229 which is of the same electrical polarity to the electrode 228 is disposed inside the groove 230 such that an electrode terminal H' of opposite electrical polarity to the electrode terminal H is defined. Namely, two electrode terminals H-H' for an input signal are constructed. On the other hand, electrodes 231, 232, 233 which are of the same electrical polarity are disposed on the side surfaces and inside the grooves 225, 237 such that an electrode terminal I is defined, while electrodes 234, 235, 236 which are of the same electrical polarity are disposed on the side surfaces and inside the grooves 225, 237 such that an electrode terminal I' of opposite electrical polarity to the electrode terminal I is defined. Namely, two electrode terminals I-I' for an output signal are constructed. The resonator of this embodiment is made of quartz crystal, but may be made of a piezoelectric material such as lithium tantalite, lithium niobate and ceramics.

[0100] FIG. 16(a) and FIG. 16(b) show a plan view and a J-J' sectional view of a quartz crystal resonator 230 of an eighth embodiment of the present invention, and which is a quartz crystal tuning fork resonator. The resonator 230 comprises vibrational arms 231 and 232 and a base portion 233 attached to the vibrational arms. In addition, each of the vibrational arms 231 and 232 has a first main surface and a

second main surface opposite the first main surface and side surfaces, and the first and second main surfaces have central linear portions 242, 243, respectively. The vibrational arm 231 has grooves 234, 235 and the vibrational arm 232 has grooves 235, 237. In addition, the grooves 234 and 236 are formed between the central linear portion 242 and an outer edge of the vibrational arm 231, respectively. Similar to this, the grooves 235 and 237 are formed between the central linear portion 243 and an outer edge of the vibrational arm 232, respectively

[0101] Moreover, each of the grooves 234, 235, 236 and 237 has a width  $W_8$ , and a width  $W_7$  including a portion of the central linear lines 242 and 243 is formed in each of the vibrational arms 231 and 232. In addition, a distance  $W_9$  is formed in the width direction of the vibrational arms 231 and 232 between an outer edge of the groove and an outer edge of the vibrational arms. In detail, a width  $W$  of the arms 231 and 232 has generally a relationship of  $W=W_7+2W_8+2W_9$ , and the width  $W_8$  is constructed so that  $W_8 \cong W_7, W_9$ . In this embodiment, also, the grooves are constructed at the arms so that a ratio  $W_8/(W/2)$  of the width  $W_8$  and a half width of the width  $W$  is greater than 0.35 and less than 1, preferably, within a range of 0.35 to 0.95. In addition, the width  $W_7$  is less than 0.05 mm, preferably, less than 0.03 mm and the width  $W_8$  is within a range of 0.015 mm to 0.05 mm to obtain a very large moment of inertia of the vibrational arms. That is, the quartz crystal tuning fork resonator, capable of vibrating in a fundamental mode, and having a frequency of high stability can be provided with a small series resistance  $R_1$ , a high quality factor  $Q_1$  and a small capacitance ratio  $r_1$  because it has a very large electromechanical transformation efficiency.

[0102] In FIG. 16(b), the vibrational arm 231 has grooves 234, 236, 238 and 240 cut into it. The grooves 234, 236, 238 and 240 have a first set of electrodes 256, 257, 258 and 259 of the same electrical polarity, while the side surfaces of the arm 231 have a second set of electrodes 244 and 245 having an opposite electrical polarity to the first set of electrodes 256, 257, 258 and 259. The vibrational arm 232 has grooves 235, 237, 239 and 241 constructed in a similar manner as the vibrational arm 231. The grooves 235, 237, 239 and 241 have a third set of electrodes 252, 253, 254 and 255 of the same electrical polarity, and the side surfaces of the vibrational arm 232 have a fourth set of electrodes 250 and 251 with the opposite electrical polarity to the third electrodes 252, 253, 254 and 255. The electrodes disposed on the vibrational arms 231 and 232 are connected as shown in FIG. 16(b), namely, two electrode terminals of different electrical polarity K-K' are obtained.

[0103] In detail, the first set of electrodes 256, 257, 258 and 259 disposed on the grooves 234, 236, 238 and 240 of the vibrational arm 231 have the same electrical polarity as the fourth set of electrodes 250 and 251 disposed on both side surfaces of the vibrational arm 232, while the second set of electrodes 244 and 245 disposed on both side surfaces of the vibrational arm 231 have the same electrical polarity as the third set of electrodes 252, 253, 254 and 255 disposed on the grooves 235, 237, 239 and 241 of the arm 232. When a direct current voltage is applied between the electrode terminals K-K', an electric field  $E_x$  occurs along the arrow direction inside the vibrational arms 231 and 232. As the electric field  $E_x$  occurs perpendicular to the electrodes disposed on the vibrational arms, as shown in the arrow signs, the electric field  $E_x$  has a very large value and a large distortion occurs at the vibrational arms. As a result, a quartz crystal tuning fork

resonator capable of vibrating in a flexural mode is obtained with a small series resistance  $R_1$  and a high quality factor  $Q$  because even when miniaturized there is a very large electro-mechanical transformation efficiency for the resonator.

[0104] FIG. 17 shows a plan view of a quartz crystal unit of a first embodiment of the present invention and omitting a lid. The quartz crystal unit 160 comprises the quartz crystal tuning fork resonator 10 shown in FIG. 2, a case 165 for housing the resonator and a lid for covering an open end of the case (not shown here). Also, the resonator 10 has mounting arms 36 and 37, each of which is mounted on a mounting portion 166 and a mounting portion 167 of the case 165. In detail, an electrode disposed on the mounting arm 36 is connected to an electrode disposed on the mounting portion 166 by adhesives 168 or a metal such as solder, and similarly, an electrode disposed on the mounting arm 37 is connected to an electrode disposed on the mounting portion 167 by adhesives 169 or a metal.

[0105] FIG. 18 shows a plan view of a quartz crystal unit of a second embodiment of the present invention and omitting a lid. The quartz crystal unit 170 comprises the quartz crystal tuning fork resonator 50 shown in FIG. 5, a case 175 for housing the resonator and a lid for covering an open end of the case (not shown here). Namely, the resonator comprises vibrational arms and a base portion. Also, the case 175 has mounting portions 176 and 177 and the resonator 50 has the mounting arm 77 which is mounted on each of the mounting portions 176 and 177 and has the first mounting arm portion including the first width  $W_6$  (see, FIG. 5) and the second mounting arm portion including the second width greater than the first width  $W_6$  and protruding from the base portion. Namely, the second mounting arm portion including the second width is mounted on the mounting portion 177 of the case 175. In detail, an electrode disposed on a surface of the second mounting arm portion of the mounting arm 77 is connected to an electrode disposed on a surface of the mounting portion 177 by adhesives 179 or a metal such as solder, and similarly, an electrode disposed on the base portion of the resonator 50 is connected to the electrode 63 disposed on the surface of the groove 61 (see, FIG. 5) and an electrode disposed on a surface of the mounting portion 176 by adhesives 178 or a metal such as solder.

[0106] FIG. 19 shows a cross-sectional view of a quartz crystal unit of a third embodiment of the present invention. The quartz crystal unit 180 comprises a contour mode quartz crystal resonator 185 or a thickness shear mode quartz crystal resonator 185, a case 181 and a lid 182. In more detail, the resonator 185 is mounted on a mounting portion 184 of the case 181 by conductive adhesives 76 or solder. Also, the case 181 and the lid 182 are connected through a connecting member 183. For example, the contour mode resonator 185 in this embodiment is the same resonator as one of the quartz crystal tuning fork resonators 10, 50, 90, 110, 120, 130, 140, 220 and 230 described in detail in FIG. 2-FIG. 11 and FIG. 15-FIG. 16.

[0107] In this embodiment, circuit elements are connected at outside of the quartz crystal unit to get a quartz crystal oscillator. Namely, only the quartz crystal tuning fork resonator is housed in the unit and also, it is housed in the unit in vacuum. In this embodiment, the quartz crystal unit of a surface mounting type is shown, but the quartz crystal tuning fork resonator may be housed in a tubular type, namely, a quartz crystal unit of the tubular type. In addition, the quartz crystal unit of the present invention includes any shape of a

quartz crystal unit comprising a quartz crystal resonator, a case and a lid to house the quartz crystal resonator in vacuum. As an example of any shape of the quartz crystal unit, when the quartz crystal tuning fork resonator 10 is formed in a quartz crystal wafer, an end portion of the mounting arm 36 is not connected to an end portion of the mounting arm 37, as is shown in FIGS. 2 and 17, but the end portion of the mounting arm 36 may be connected to the end portion of the mounting arm 37 in the quartz crystal wafer to get a connected (closed) mounting arm. In detail, the connected (closed) mounting arm comprises one end portion and the other end portion each connected to the base portion. Also, each of the connected mounting arm and the base portion has an upper face and a lower face, namely, a first surface and a second surface opposite the first surface. For this case, a quartz crystal unit comprises a case and a lid, and each of the case and the lid has an interior space and an open end. Also, the lower face (the second surface) of each of the connected mounting arm and the base portion is mounted on a mounting portion of the case and the upper face (the first surface) of each of the connected mounting arm and the base portion is mounted on a mounting portion of the lid, namely, the lower face (the second surface) of each of the connected mounting arm and the base portion is connected to the open end of the case and the upper face (the first surface) of each of the connected mounting arm and the base portion is connected to the open end of the lid to cover the open end of each of the case and the lid. A width of the open end of each of the lid and the case is less, preferably, equal to, more preferably, greater than a width of the connected mounting arm and/or the base portion to get a big connected power. When each of the case and the lid has no through hole, at least one of the open end of the case and open end of the lid is connected to the corresponding one of the upper and lower faces of each of the connected mounting arm and the base portion so that the quartz crystal tuning fork resonator is maintained in a vacuum, and when one of the case and the lid has a through hole including a first diameter and a second diameter greater than the first diameter, a metal or a glass is disposed into the through hole of the second diameter to close the through hole of one of the case and the lid in a vacuum after the open end of each of the case and the lid is connected to the corresponding one of the upper and lower faces of each of the connected mounting arm and the base portion. As above-described, the base portion is located between the open end of the case and the open end of the lid, for example, a part having an area of the base portion is located between the open end of the case and the open end of the lid. It is needless to say that the quartz crystal tuning fork tines are located between the interior space of the case and the interior space of the lid. Also, the connection of the open end of the case is performed simultaneously with the connection of the open end of the lid, but, according to the present invention, the connection of the open end of the case may be performed in a step different from the connection of the open end of the lid, namely, the connection of the open end of the case is performed after or before the connection of the open end of the lid is performed. Also, a first electrode (metal film) is disposed on each of a surface of the open end of the lid and the upper face of each of the connected mounting arm and the base portion and a second electrode (metal film) is disposed on each of a surface of the open end of the case and the lower face of each of the connected mounting arm and the base portion. The lid is connected to the connected mounting arm and the base portion through the first electrode disposed on

the surface of the open end of the lid and the first electrode disposed on the upper face of each of the connected mounting arm and the base portion, while the case is connected to the connected mounting arm and the base portion through the second electrode disposed on the surface of the open end of the case and the second electrode disposed on the lower face of each of the connected mounting arm and the base portion. Namely, each of the connection of the lid and the connected mounting arm and the base portion and the connection of the case and the connected mounting arm and the base portion is performed by an anode connection method. In addition, the first electrode disposed on each of the surface of the open end of the lid and the upper face of each of the connected mounting arm and the base portion has an electrical polarity opposite to an electrical polarity of the second electrode disposed on each of the surface of the open end of the case and the lower face of each of the connected mounting arm and the base portion. Also, the case and the lid are made of a piezoelectric material such as quartz crystal or a glass or ceramics and have a thermal expansion coefficient less than that of the quartz crystal tuning fork resonator. In addition, the present invention includes the following example, namely, one of the case and the lid comprises a plurality of through holes having a first through hole and a second through hole and an electrode is disposed on a surface of each of the first and second through holes. In addition, one of the case and the lid comprises a first electrode and a second electrode each of which is disposed on an outer surface of the one of the case and the lid. Also, the vibrational arms shown in FIG. 3 having two electrode terminals including first and second electrode terminals are located between an inner surface in the interior space of the case and an inner surface in the interior space of the lid, and the first electrode terminal of the vibrational arms is connected to the first electrode disposed on the outer surface of the one of the case and the lid through the electrode disposed on the surface of the first through hole and the second electrode terminal of the vibrational arms is connected to the second electrode disposed on the outer surface of the one of the case and the lid through the electrode disposed on the surface of the second through hole. In this embodiment, one of the case and the lid comprises the first and second through holes, but this invention is not limited to this, namely, the lid comprises an outer surface on which a first electrode is disposed and a first through hole having a surface on which an electrode is disposed and the case comprises an outer surface on which a second electrode is disposed and a second through hole having a surface on which an electrode is disposed. For this case, the first electrode terminal of the vibrational arms is connected to the first electrode disposed on the outer surface of the lid through the electrode disposed on the surface of the first through hole of the lid and the second electrode terminal of the vibrational arms is connected to the second electrode disposed on the outer surface of the case through the electrode disposed on the surface of the second through hole of the case. In addition, a metal or a glass is disposed into each of the first and second through holes to close each of the first and second through holes and at least one of the first and second through holes is closed in a vacuum using the metal or the glass.

**[0108]** Also, instead of the quartz crystal tuning fork resonator and the thickness shear mode quartz crystal resonator, one of a length-extensional mode quartz crystal resonator, a width-extensional mode quartz crystal resonator and a Lamé mode quartz crystal resonator which are a contour mode quartz crystal resonator, respectively, or a SAW (Surface

Acoustic Wave) resonator or a piezoelectric resonator for sensing angular velocity (angular velocity sensor) made of quartz crystal or ceramics may be housed in the unit.

**[0109]** In addition, a member of the case and the lid is ceramics or glass and a metal or glass, respectively, and a connecting member is a metal or glass with low melting point. Also, a relationship of the resonator, the case and the lid described in this embodiment is applied to a quartz crystal oscillator of the present invention which will be described in FIG. 20.

**[0110]** FIG. 20 shows a cross-sectional view of a quartz crystal oscillator of a first embodiment of the present invention. The quartz crystal oscillator 190 comprises a quartz crystal oscillating circuit, a case 191 and a lid 192. In this embodiment, circuit elements constructing the oscillating circuit are housed in a quartz crystal unit comprising a contour mode quartz crystal resonator 195 or a thickness shear mode quartz crystal resonator 195, the case 191 and the lid 192. Also, the oscillating circuit of this embodiment comprises an amplifier 197 including a feedback resistor, the resonator 195, a plurality of capacitors (not shown here) and a drain resistor (not shown here), and a CMOS inverter is used as the amplifier 197.

**[0111]** In addition, in this embodiment, the resonator 195 is mounted on a mounting portion 194 of the case 191 by conductive adhesives 196 or solder. As described above, the amplifier 197 is housed in the quartz crystal unit and mounted on the case 191. Also, the case 191 and the lid 192 are connected through a connecting member 193.

**[0112]** FIG. 21 shows a diagram of an embodiment of a quartz crystal oscillating circuit constructing a quartz crystal oscillator of the present invention. The quartz crystal oscillating circuit 201 comprises an amplifier (CMOS inverter) 202, a feedback resistor 204, a drain resistor 207, a plurality of capacitors 205, 206 and a quartz crystal resonator 203. Namely, the oscillating circuit 201 comprises an amplification circuit 208 having the amplifier 202 and the feedback resistor 204, and a feedback circuit 209 having the drain resistor 207, the capacitors 205, 206 and the quartz crystal resonator 203. The quartz crystal resonator 203 is one of the resonators already described above. For example, when the resonator 203 is a quartz crystal tuning fork resonator capable of vibrating in a flexural mode, an output signal of the oscillating circuit 201 is outputted through a buffer circuit (not shown in FIG. 21), and is an oscillating frequency of a fundamental mode of vibration of the resonator.

**[0113]** In other words, the oscillation frequency of the fundamental mode of vibration of the quartz crystal tuning fork resonator is outputted from the oscillating circuit through the buffer circuit as an output signal. According to the present invention, a nominal frequency of the fundamental mode of vibration of the quartz crystal tuning fork resonator is within a range of 10 kHz to 200 kHz. Especially, a frequency of 32.768 kHz is very available for use in an electronic apparatus of the present invention. In general, the output signal has an oscillation frequency which is within a range of -100 PPM to +100 PPM to the nominal frequency, e.g. 32.768 kHz.

**[0114]** In more detail, the quartz crystal oscillator in this example comprises a quartz crystal oscillating circuit and a buffer circuit, namely, the quartz crystal oscillating circuit comprises an amplification circuit and a feedback circuit, and the amplification circuit comprises an amplifier (CMOS inverter) and a feedback resistor and the feedback circuit comprises a quartz crystal tuning fork resonator capable of

vibrating in a flexural mode, a drain resistor and a plurality of capacitors. Also, the quartz crystal tuning fork resonator already described in FIG. 2-FIG. 11 and FIG. 15-FIG. 16 is used in a quartz crystal oscillator of the present invention. Instead of the quartz crystal tuning fork resonator, another contour mode quartz crystal resonator such as a length-extensional mode quartz crystal resonator, a width-extensional mode quartz crystal resonator and a Lamé mode quartz crystal resonator or a thickness shear mode quartz crystal resonator or a resonator for sensing angular velocity may be used.

[0115] FIG. 22 shows a diagram of the feedback circuit of FIG. 21. In this embodiment, the feedback circuit has a quartz crystal tuning fork resonator capable of vibrating in a flexural mode. Now, when angular frequency  $\omega$ , of the quartz crystal tuning fork resonator 203, a resistance value  $R_d$  of the drain resistor 207, capacitance values  $C_g, C_d$  of the capacitors 205, 206, crystal impedance  $R_{ei}$  of the quartz crystal resonator 203, an input voltage  $V_1$ , and an output voltage  $V_2$  are taken, a feedback rate  $\beta_i$  is defined by  $\beta_i = |V_2|/|V_1|$ , where  $i$  shows a vibration order, for example, when  $i=1$  and 2,  $\beta_1$  and  $\beta_2$  are a feedback rate for a fundamental mode of vibration and a second overtone mode of vibration of the resonator, respectively.

[0116] In addition, load capacitance  $C_L$  is given by  $C_L = C_g C_d / (C_g + C_d)$ , and when  $C_g = C_d = C_{gd}$  and  $R_d \gg R_{ei}$ , the feedback rate  $\beta_i$  is given by  $\beta_i = 1 / (1 + k C_L^2)$ , where  $k$  is expressed by a function of  $\omega, R_d$  and  $R_{ei}$ . Also,  $R_{ei}$  is approximately equal to series resistance  $R_i$  of the resonator.

[0117] Thus, it is easily understood from a relationship of the feedback rate  $\beta_i$  and load capacitance  $C_L$  that the feedback rate of a resonance frequency for the fundamental mode of vibration and the overtone mode vibration becomes large, respectively, according to decrease of load capacitance  $C_L$ . Therefore, when  $C_L$  has a small value, an oscillation of the overtone mode occurs very easily, instead of that of the fundamental mode. This is the reason why maximum amplitude of the overtone mode of vibration becomes smaller than that of the fundamental mode of vibration, and the oscillation of the overtone mode satisfies an amplitude condition and a phase condition simultaneously which are the continuous condition of an oscillating circuit.

[0118] As it is also one object of the present invention to provide a quartz crystal oscillator having a flexural mode, quartz crystal tuning fork resonator, capable of vibrating in a fundamental mode and having a frequency of high stability (high time accuracy) of an output signal, and having reduced electric current consumption, load capacitance  $C_L$  is less than 25 pF in this embodiment to reduce electric current consumption. To get much reduced electric current consumption,  $C_L$  is preferably less than 15 pF because the electric current consumption is proportional to  $C_L$ . More preferably,  $C_L$  is greater than 2 pF and less than 15 pF to satisfy each of the reduced electric current consumption and a phase condition of a second overtone mode of vibration of the resonator insufficient in an oscillation circuit of the oscillator.

[0119] In addition, in order to suppress the second overtone mode of vibration of the resonator and to obtain the quartz crystal oscillator having an output signal of an oscillation frequency of a fundamental mode of vibration of the resonator, the quartz crystal oscillator comprising an amplification circuit and a feedback circuit is constructed so that it satisfies a relationship of  $\alpha_1/\alpha_2 > \beta_2/\beta_1$  and  $\alpha_1\beta_1 > 1$ , where  $\alpha_1$  and  $\alpha_2$  are, respectively, an amplification rate of the fundamental mode of vibration and the second overtone mode of vibration

of the amplification circuit, and  $\beta_1$  and  $\beta_2$  are, respectively, a feedback rate of the fundamental mode of vibration and the second overtone mode of vibration of the feedback circuit.

[0120] In other words, the quartz crystal oscillator is constructed so that a ratio of the amplification rate  $\alpha_1$  of the fundamental mode of vibration and the amplification rate  $\alpha_2$  of the second overtone mode of vibration of the amplification circuit is greater than that of the feedback rate  $\beta_2$  of the second overtone mode of vibration and the feedback rate  $\beta_1$  of the fundamental mode of vibration of the feedback circuit, and also a product of the amplification rate  $\alpha_1$  and the feedback rate  $\beta_1$  of the fundamental mode of vibration is greater than 1. A description of a frequency of high stability in the quartz crystal oscillator will be performed later.

[0121] Also, characteristics of the amplifier of the amplification circuit constructing the quartz crystal oscillating circuit of this embodiment can be expressed by negative resistance  $-RL_i$ . For example, when  $i=1$ , negative resistance  $-RL_1$  is for a fundamental mode of vibration of the resonator and when  $i=2$ , negative resistance  $-RL_2$  is for a second overtone mode of vibration of the resonator. In this embodiment, the quartz crystal oscillating circuit is constructed so that a ratio of an absolute value of negative resistance  $-RL_1$  of the fundamental mode of vibration of the amplification circuit and series resistance  $R_1$  of the fundamental mode of vibration is greater than that of an absolute value of negative resistance  $-RL_2$  of the second overtone mode of vibration of the amplification circuit and series resistance  $R_2$  of the second overtone mode of vibration.

[0122] That is, the oscillating circuit is constructed so that it satisfies a relationship of  $|-RL_1|/R_1 > |-RL_2|/R_2$ . By constructing the oscillating circuit like this, an oscillation of the second overtone mode can be suppressed, as a result of which a frequency of oscillation of the fundamental mode of vibration can be output as an output signal because the oscillation of the fundamental mode generates easily in the oscillating circuit. In more detail, an absolute value of the negative resistance  $-RL_1$  is greater than 55 k $\Omega$  and less than 800 k $\Omega$ , preferably, within a range of 60 k $\Omega$  to 500 k $\Omega$ , more preferably, within a range of 60 k $\Omega$  to 285 k $\Omega$ , and an absolute value of the negative resistance  $-RL_2$  is less than 200 k $\Omega$ , preferably, less than 105 k $\Omega$ , more preferably, less than 80 k $\Omega$  to suppress the frequency of oscillation of the second overtone mode of the quartz crystal tuning fork resonator in the oscillating circuit and to obtain the frequency of oscillation of the fundamental mode thereof.

[0123] In this embodiment, a quartz crystal tuning fork resonator is used, but, instead of the tuning fork resonator, another contour mode quartz crystal resonator such as a width-extensional mode quartz crystal resonator, a length-extensional mode quartz crystal resonator and a Lamé mode quartz crystal resonator may be used in a quartz crystal oscillator of the present invention. In this case, a principal vibration of the contour mode quartz crystal resonator is outputted from an oscillating circuit constructing the quartz crystal oscillator through a buffer circuit. In order to suppress a sub-vibration of the contour mode quartz crystal resonator, the quartz crystal oscillator comprising an amplification circuit and a feedback circuit is constructed so that it satisfies a relationship of  $\alpha_p/\alpha_s > \beta_s/\beta_p$  and  $\alpha_p\beta_p > 1$ , where  $\alpha_p$  and  $\alpha_s$  are, respectively, an amplification rate of the principal vibration and the sub-vibration of the amplification circuit, and  $\beta_p$  and  $\beta_s$  are, respectively, a feedback rate of the principal vibration and the sub-vibration of the feedback circuit.

**[0124]** Similar to the quartz crystal tuning fork resonator, for the contour mode quartz crystal resonator, a quartz crystal oscillating circuit of the present invention is constructed so that a ratio of an absolute value of negative resistance  $-RL_p$  of the principal vibration of the amplification circuit and a series resistance  $R_p$  of the principal vibration is greater than that of an absolute value of negative resistance  $-RL_s$  of the sub-vibration of the amplification circuit and a series resistance  $R_s$  of the sub-vibration. That is, the oscillating circuit is constructed so that it satisfies a relationship of  $|-RL_p/R_p| > |-RL_s/R_s|$ . By constructing the oscillating circuit like this, an oscillation of the sub-vibration can be suppressed, as a result of which a frequency of oscillation of the principal vibration can be outputted as an output signal because the oscillation of the principal vibration generates easily in the oscillating circuit. In addition, the principal vibration and the sub-vibration have the same mode of vibration and a different order of vibration each other.

**[0125]** FIG. 23 shows a block diagram of an embodiment of an electronic apparatus of the present invention, and illustrating the diagram of a facsimile apparatus. As shown in FIG. 23, the apparatus generally comprises a modem, a phonetic circuit, a timepiece circuit, a printing portion, a taking portion, an operation portion and a display portion. In this principle, perception and scanning of reflection light of light projected on manuscript in the taking portion are performed by CCD (Charge Coupled Device), in addition, light and shade of the reflection light are transformed into a digital signal, and the signal is modulated by the modem and is sent to a phone line (communication line). Also, in a receiving side, a received signal is demodulated by the modem and is printed on a paper in the print portion by synchronizing the received signal with a signal of a sending side. In addition, the display portion comprises at least one of a liquid crystal display (LCD) portion, a plasma display panel (PDP) portion, a surface-conduction electron-emitter display (SED) portion and an organic electroluminescence display (OED) portion.

**[0126]** In FIG. 23, a quartz crystal resonator is used as a CPU clock of the control portion and the printing portion, as a clock of the phonetic circuit and the modem, and as a time standard of the timepiece. Namely, the resonator constructs a quartz crystal oscillator and an output signal of the oscillator is used. Like this, a plurality of oscillators is used for the electronic apparatus. For example, it is used as a signal to display time at the display portion. In this case, a quartz crystal tuning fork resonator, capable of vibrating in a flexural mode is generally used, and e.g. as the CPU clock, a contour mode quartz crystal resonator such as a length-extensional mode quartz crystal resonator, a width-extensional mode quartz crystal resonator and a Lamé mode quartz crystal resonator or a thickness shear mode quartz crystal resonator is used. To get the facsimile apparatus of this embodiment which operates normally, an accuracy signal of output of the oscillator is required for the facsimile apparatus, which is one of the electronic apparatus of the present invention. Also, a digital display and an analogue display are included in the display of the present invention.

**[0127]** In this embodiment, though the facsimile apparatus is shown as an example of an electronic apparatus of the present invention, the present invention is not limited to this, namely, the present invention includes all electronic apparatus, each of which comprises a quartz crystal oscillator and a display portion at least, for example, cellular phones, telephones, a TV set, cameras, a video set, video cameras, pagers,

personal computers, printers, CD players, MD players, electronic musical instruments, car navigators, car electronics, timepieces, IC cards and so forth. In addition, the electronic apparatus may have another oscillator comprising a piezoelectric resonator for sensing angular velocity made of quartz crystal, ceramics, lithium tantalite and lithium niobate. Also, the electronic apparatus of the present invention may comprise a battery (cell), e.g. a lithium battery or a fuel cell which is housed in the electronic apparatus of the present invention.

**[0128]** Thus, the electronic apparatus of the present invention comprising a display portion and a quartz crystal oscillator at least may operate normally because the quartz crystal oscillator comprises the quartz crystal oscillating circuit with a frequency of high stability, namely, a frequency of high reliability.

**[0129]** Moreover, capacitance ratios  $r_1$  and  $r_2$  of a flexural mode, quartz crystal tuning fork resonator are given by  $r_1 = C_0/C_1$  and  $r_2 = C_0/C_2$ , respectively, where  $C_0$  is shunt capacitance in an electrical equivalent circuit of the resonator, and  $C_1$  and  $C_2$  are, respectively, motional capacitance of a fundamental mode of vibration and a second overtone mode of vibration in the electrical equivalent circuit of the resonator. In addition, the resonator has a quality factor  $Q_1$  for the fundamental mode of vibration and a quality factor  $Q_2$  for the second overtone mode of vibration. Also, the motional capacitance  $C_1$  of the fundamental mode of vibration of the resonator is greater than the motional capacitance  $C_2$  of the second overtone mode of vibration thereof from the relationship of  $r_1$  less than  $r_2$  shown in the paragraph [0037]. In addition, a ratio  $(L_{1m}/L_{2m})$  of a motional inductance  $L_{1m}$  of the fundamental mode of vibration of the resonator and a motional inductance  $L_{2m}$  of the second overtone mode of vibration thereof is less than 42 approximately from the relationships of  $r_1$  less than  $r_2$  and  $\omega_2 = 6.5\omega_1$  approximately, where  $\omega_1$  and  $\omega_2$  represent an angular frequency of the fundamental mode of vibration and the second overtone mode of vibration, respectively, of the resonator. Also the ratio  $(L_{1m}/L_{2m})$  is less than  $6.5(Q_1/Q_2)$  from the relationship of  $R_1 < R_2$ . As a result, an output signal having an oscillation frequency of the fundamental mode of vibration of the resonator is output in an oscillating circuit through a buffer circuit because a phase condition of the fundamental mode of vibration is much better than that of the second overtone mode of vibration in the oscillating circuit.

**[0130]** In detail, the tuning fork resonator of this embodiment is provided so that the influence on resonance frequency of the fundamental mode of vibration by the shunt capacitance becomes smaller than that of the second overtone mode of vibration by the shunt capacitance, namely, so that it satisfies a relationship of  $S_1 = r_1/2Q_1^2 < S_2 = r_2/2Q_2^2$ , preferably,  $S_1 < S_2/2$ , where  $S_1$  and  $S_2$  are called "a stable factor of frequency" of the fundamental mode of vibration and the second overtone mode of vibration. As a result, the tuning fork resonator, capable of vibrating in the fundamental mode and having a frequency of high stability can be provided because the influence on the resonance frequency of the fundamental mode of vibration by the shunt capacitance  $C_0$  is as extremely small as it can be ignored. In this embodiment  $S_2$  has a value greater than  $0.13 \times 10^{-6}$  to suppress the second overtone mode of vibration of the resonator.

**[0131]** In addition, as described above, it will be easily understood that the quartz crystal resonator comprising vibrational arms and a base portion, according to the present invention, may have outstanding effects. Similar to this, the quartz crystal unit and the quartz crystal oscillator, according to the

present invention, may have also outstanding effects. In addition, the electronic apparatus comprising the quartz crystal oscillator comprising the quartz crystal oscillating circuit having the quartz crystal tuning fork resonator, capable of vibrating in a flexural mode, and having novel shapes, novel electrode construction and excellent electrical characteristics, according to the present invention, may have the outstanding effects. Similar to this, it will be easily understood that the electronic apparatus comprising the quartz crystal oscillator comprising the quartz crystal oscillating circuit having the another contour mode quartz crystal resonator or the thickness shear mode quartz crystal resonator or the resonator for sensing angular velocity, according to the present invention, may have also the outstanding effect. In addition to this, while the present invention has been shown and described with reference to preferred embodiments thereof, it will be understood by those skilled in the art that the changes in shape and electrode construction can be made therein without departing from the spirit and scope of the present invention.

What is claimed is:

1. A quartz crystal unit comprising:

a quartz crystal resonator having a base portion, and first and second vibrational arms connected to the base portion, each of the first and second vibrational arms having opposite main surfaces;

wherein at least one groove is formed in at least one of the opposite main surfaces of each of the first and second vibrational arms;

wherein a length of the base portion is less than 0.5 mm and an overall length of the quartz crystal resonator is less than 2.1 mm; and

wherein at least one mounting arm protrudes from the base portion and is formed between the first and second vibrational arms, the at least one mounting arm extending in a common direction with the first and second vibrational arms.

2. A quartz crystal unit according to claim 1; wherein each of the first and second vibrational arms has a width  $W$ ; wherein each of a first spaced-apart distance between the first vibrational arm and the at least one mounting arm and a second spaced-apart distance between the second vibrational arm and the at least one mounting arm is defined by  $W_{10}$ ; wherein the at least one mounting arm has a width  $W_{11}$ ; wherein a width  $W_r$  is defined by  $(2W + 2W_{10} + W_{11})$ ; and wherein the width  $W_r$  is less than 1.3 mm.

3. A quartz crystal unit according to claim 1; wherein the length of the base portion is within a range of 0.015 mm to 0.49 mm; and wherein the at least one groove is formed in the at least one of the opposite main surfaces of each of the first and second vibrational arms so that a width of the at least one groove formed in the at least one of the opposite main surfaces of each of the first and second vibrational arms is less than 0.07 mm and a distance in the width direction of the at least one groove measured from an outer edge of the at least one groove to an outer edge of the corresponding one of the first and second vibrational arms is less than 0.015 mm.

4. A quartz crystal unit according to claim 1; wherein a spaced-apart distance between the first vibrational arm and the at least one mounting arm is within a range of 0.032 mm to 0.21 mm.

5. A quartz crystal unit according to claim 1; wherein each of the first and second vibrational arms has a width  $W$ ;

wherein the at least one mounting arm has a width  $W_{11}$ ; and wherein the width  $W_{11}$  has a value of  $(1.2 \text{ to } 7.6) \times W$ .

6. A quartz crystal unit according to claim 5; wherein the width  $W$  is greater than 0.05 mm and less than 0.1 mm.

7. A quartz crystal unit according to claim 1; wherein each of the first and second vibrational arms comprises a first vibrational portion having a first width  $W$  and a second vibrational portion having a second width  $W_e$  greater than the first width  $W$ , the first vibrational portion of each of the first and second vibrational arms having a first main surface and a second main surface opposite the first main surface; wherein the at least one groove comprises a groove formed in at least one of the first and second main surfaces of the first vibrational portion of each of the first and second vibrational arms so that a width of the groove formed in the at least one of the first and second main surfaces of the first vibrational portion of each of the first and second vibrational arms is less than 0.07 mm and a distance in the width direction of the groove measured from an outer edge of the groove to an outer edge of the corresponding one of the first and second vibrational arms is less than 0.015 mm; and further comprising a case having a mounting portion and a lid for covering an open end of the case; wherein the at least one mounting arm is mounted on the mounting portion of the case; and wherein the lid is connected to the case to cover the open end of the case.

8. A quartz crystal unit according to claim 7; wherein each of a first spaced-apart distance between the first vibrational arm and the at least one mounting arm and a second spaced-apart distance between the second vibrational arm and the at least one mounting arm is defined by  $W_{10}$ ; wherein the at least one mounting arm has a width  $W_{11}$ ; wherein a width  $W_r$  is defined by  $(2W + 2W_{10} + W_{11})$ ; wherein the width  $W_r$  is less than 1.3 mm; wherein each of the first spaced-apart distance  $W_{10}$  and the second spaced-apart distance  $W_{10}$  is within a range of 0.032 mm to 0.21 mm; wherein the at least one mounting arm has first and second arm portions; wherein a first electrode is disposed on a surface of the first arm portion of the at least one mounting arm and a second electrode is disposed on a surface of the second arm portion of the at least one mounting arm; wherein a third electrode is disposed on a surface of the groove formed in the at least one of the first and second main surfaces of the first vibrational portion of each of the first and second vibrational arms; wherein the first electrode disposed on the surface of the first arm portion of the at least one mounting arm is electrically connected to the third electrode disposed on the surface of the groove formed in the at least one of the first and second main surfaces of the first vibrational portion of the first vibrational arm; and wherein the second electrode disposed on the surface of the second arm portion of the at least one mounting arm is electrically connected to the third electrode disposed on the surface of the groove formed in the at least one of the first and second main surfaces of the first vibrational portion of the second vibrational arm.

9. A quartz crystal unit according to claim 1; wherein the opposite main surfaces have a first main surface and a second main surface; wherein the at least one groove comprises a plurality of grooves having a first groove and a second groove formed in at least one of the first and second main surfaces of each of the first and second vibrational arms, each of the first and second grooves having a first outer edge and a second outer edge opposite the first outer edge in the width direction and each of the first and second vibrational arms having a first outer edge and a second outer edge opposite the first outer

edge in the width direction; wherein a width of the first groove formed in the at least one of the first and second main surfaces of each of the first and second vibrational arms is greater than or equal to a first distance in the width direction of the first groove measured from the first outer edge of the first groove to the first outer edge of the corresponding one of the first and second vibrational arms; wherein a width of the second groove formed in the at least one of the first and second main surfaces of each of the first and second vibrational arms is greater than or equal to a second distance in the width direction of the second groove measured from the first outer edge of the second groove to the second outer edge of the corresponding one of the first and second vibrational arms; and further comprising a case having a mounting portion and a lid for covering an open end of the case; wherein the at least one mounting arm is mounted on the mounting portion of the case; and wherein the lid is connected to the case to cover the open end of the case.

**10.** A quartz crystal unit according to claim **9**; wherein a third distance in the width direction of the first and second grooves measured from the second outer edge of the first groove to the second outer edge of the second groove is less than 0.05 mm.

**11.** A quartz crystal unit according to claim **1**; wherein the quartz crystal resonator comprises a quartz crystal tuning fork resonator having a quartz crystal tuning fork base, and first and second quartz crystal tuning fork arms connected to the quartz crystal tuning fork base; wherein an overall length of the quartz crystal tuning fork resonator is less than 2.1 mm and a length of the quartz crystal tuning fork base is within a range of 0.015 mm to 0.49 mm, each of the first and second quartz crystal tuning fork arms having a first main surface and a second main surface opposite the first main surface; wherein the at least one groove comprises a plurality of grooves having a first groove and a second groove formed in at least one of the first and second main surfaces of each of the first and second quartz crystal tuning fork arms; wherein a distance in the width direction of the first and second grooves measured from an outer edge of the first groove to an outer edge of the second groove is defined by  $W_7$ ; wherein the distance  $W_7$  is less than 0.05 mm; wherein the at least one mounting arm comprises a mounting arm connected to the quartz crystal tuning fork base and formed between the first and second quartz crystal tuning fork arms, the mounting arm extending in a common direction with the first and second quartz crystal tuning fork arms; and further comprising a case having a mounting portion and a lid for covering an open end of the case; wherein the mounting arm is mounted on the mounting portion of the case; and wherein the lid is connected to the case to cover the open end of the case.

**12.** A quartz crystal unit according to claim **1**; wherein the quartz crystal resonator comprises a quartz crystal tuning fork resonator having a quartz crystal tuning fork base, and first and second quartz crystal tuning fork arms connected to the quartz crystal tuning fork base, wherein an overall length of the quartz crystal tuning fork resonator is less than 2.1 mm and a length of the quartz crystal tuning fork base is within a range of 0.015 mm to 0.49 mm; wherein the at least one mounting arm comprises a mounting arm connected to the quartz crystal tuning fork base and formed between the first and second quartz crystal tuning fork arms, the mounting arm extending in a common direction with the first and second quartz crystal tuning fork arms; and further comprising a case having a mounting portion and a lid for covering an open end

of the case; wherein the mounting arm is mounted on the mounting portion of the case; and wherein the lid is connected to the case to cover the open end of the case.

**13.** A quartz crystal unit according to claim **12**; wherein each of the first and second quartz crystal tuning fork arms comprises a first vibrational portion having a first width  $W$  and a second vibrational portion having a second width  $W_e$  greater than the first width  $W$ , the first vibrational portion of each of the first and second quartz crystal tuning fork arms having a first main surface and a second main surface opposite the first main surface; and wherein the at least one groove comprises a groove formed in at least one of the first and second main surfaces of the first vibrational portion of each of the first and second quartz crystal tuning fork arms so that a width of the groove formed in the at least one of the first and second main surfaces of the first vibrational portion of each of the first and second quartz crystal tuning fork arms is less than 0.07 mm.

**14.** A quartz crystal unit according to claim **13**; wherein the groove is formed in each of the first and second main surfaces of the first vibrational portion of each of the first and second quartz crystal tuning fork arms so that a distance in the width direction of the groove measured from an outer edge of the groove to an outer edge of the corresponding one of the first and second quartz crystal tuning fork arms is less than 0.015 mm.

**15.** A quartz crystal unit according to claim **12**; wherein each of the first and second quartz crystal tuning fork arms has a first main surface and a second main surface opposite the first main surface; wherein the at least one groove comprises a plurality of grooves having a first groove and a second groove formed in at least one of the first and second main surfaces of each of the first and second quartz crystal tuning fork arms, each of the first and second grooves having a first outer edge; wherein a first distance in the width direction of the first and second grooves measured from the first outer edge of the first groove to the first outer edge of the second groove is defined by  $W_7$ ; and wherein the first distance  $W_7$  is less than 0.05 mm.

**16.** A quartz crystal unit according to claim **15**; wherein each of the first and second grooves formed in the at least one of the first and second main surfaces of each of the first and second quartz crystal tuning fork arms has a second outer edge opposite the first outer edge in the width direction and each of the first and second quartz crystal tuning fork arms has a first outer edge and a second outer edge opposite the first outer edge in the width direction; wherein a width of the first groove formed in the at least one of the first and second main surfaces of each of the first and second quartz crystal tuning fork arms is greater than or equal to a second distance in the width direction of the first groove measured from the second outer edge of the first groove to the first outer edge of the corresponding one of the first and second quartz crystal tuning fork arms;

wherein a width of the second groove formed in the at least one of the first and second main surfaces of each of the first and second quartz crystal tuning fork arms is greater than or equal to a third distance in the width direction of the second groove measured from the second outer edge of the second groove to the second outer edge of the corresponding one of the first and second quartz crystal tuning fork arms.

**17.** A quartz crystal unit according to claim **12**; wherein each of the first and second quartz crystal tuning fork arms has



a width  $W$ ; wherein a first spaced-apart distance between the first quartz crystal tuning fork arm and the mounting arm is defined by  $W_{10}$  and a second spaced-apart distance between the second quartz crystal tuning fork arm and the mounting arm is defined by  $W_{10}$ ; wherein the mounting arm has a width  $W_{11}$ ; wherein a width  $W_z$  is defined by  $(2W + 2W_{10} + W_{11})$ ; wherein the width  $W_z$  is less than 1.3 mm; and wherein each of the first spaced-apart distance  $W_{10}$  and the second spaced-apart distance  $W_{10}$  is within a range of 0.032 mm to 0.21 mm.

**18.** A quartz crystal unit according to claim **1**; wherein the quartz crystal resonator comprises a quartz crystal tuning fork resonator having a quartz crystal tuning fork base, and first and second quartz crystal tuning fork arms connected to the quartz crystal tuning fork base, each of the first and second quartz crystal tuning fork arms comprising a plurality of vibrational portions having a first vibrational portion including a first width  $W$  and a second vibrational portion including a second width  $W_e$  greater than the first width  $W$ , the first vibrational portion of each of the first and second quartz crystal tuning fork arms having a first main surface and a second main surface opposite the first main surface; wherein the at least one groove comprises a groove formed in each of the first and second main surfaces of the first vibrational portion of each of the first and second quartz crystal tuning fork arms so that a width of the groove formed in each of the first and second main surfaces of the first vibrational portion of each of the first and second quartz crystal tuning fork arms is less than 0.07 mm and a length of the groove formed in each of the first and second main surfaces of the first vibrational portion of each of the first and second quartz crystal tuning fork arms is within a range of 0.45 mm to 1.25 mm; wherein an overall length of the quartz crystal tuning fork resonator is less than 2.1 mm and a length of the quartz crystal tuning fork base is within a range of 0.015 mm to 0.49 mm; wherein the at least one mounting arm comprises a mounting arm connected to the quartz crystal tuning fork base and formed between the first and second quartz crystal tuning fork arms, the mounting arm extending in a common direction with the first and second quartz crystal tuning fork arms; wherein each of a first spaced-apart distance between the first quartz crystal tuning fork arm and the mounting arm and a second spaced-apart distance between the second quartz crystal tuning fork arm and the mounting arm is defined by  $W_{10}$ ; wherein the mounting arm has a width  $W_{11}$ ; wherein a width  $W_z$  is defined by  $(2W + 2W_{10} + W_{11})$ ; wherein the width  $W_z$  is less than 1.3 mm; and further comprising a case having a mounting portion and a lid for covering an open end of the case; wherein the mounting arm is mounted on the mounting portion of the case; and wherein the lid is connected to the case to cover the open end of the case.

**19.** A quartz crystal unit according to claim **18**; wherein a first distance in the width direction of the groove measured from a first outer edge of the groove to a first outer edge of the corresponding one of the first and second quartz crystal tuning fork arms is defined by  $W_1$  and a second distance in the width direction of the groove measured from a second outer edge opposite the first outer edge of the groove to a second outer edge opposite the first outer edge of the corresponding one of the first and second quartz crystal tuning fork arms is defined by  $W_3$ ; and wherein at least one of the first distance  $W_1$  and the second distance  $W_3$  is less than 0.015 mm.

**20.** A quartz crystal oscillator comprising: a quartz crystal unit having a quartz crystal resonator including a base portion, and first and second vibrational arms connected to the

base portion, each of the first and second vibrational arms having opposite main surfaces;

wherein at least one groove is formed in at least one of the opposite main surfaces of each of the first and second vibrational arms;

wherein a length of the base portion is less than 0.5 mm and an overall length of the quartz crystal resonator is less than 2.1 mm; and

wherein at least one mounting arm protrudes from the base portion and is formed between the first and second vibrational arms, the at least one mounting arm extending in a common direction with the first and second vibrational arms.

**21.** A quartz crystal oscillator according to claim **20**; wherein each of the first and second vibrational arms comprises a first vibrational portion having a first width  $W$  and a second vibrational portion having a second width  $W_e$  greater than the first width  $W$ , the first vibrational portion of each of the first and second vibrational arms having a first main surface and a second main surface opposite the first main surface; wherein the at least one groove comprises a groove formed in at least one of the first and second main surfaces of the first vibrational portion of each of the first and second vibrational arms so that a width of the groove formed in the at least one of the first and second main surfaces of the first vibrational portion of each of the first and second vibrational arms is less than 0.07 mm; wherein each of a first spaced-apart distance between the first vibrational portion of the first vibrational arm and the at least one mounting arm, and a second spaced-apart distance between the first vibrational portion of the second vibrational arm and the at least one mounting arm is defined by  $W_{10}$ ; wherein a width of the at least one mounting arm is defined by  $W_{11}$ ; wherein a width  $W_z$  is defined by  $(2W + 2W_{10} + W_{11})$ ; wherein the width  $W_z$  is less than 1.3 mm; wherein the length of the base portion is within a range of 0.015 mm to 0.49 mm; and further comprising a case having a mounting portion and a lid for covering an open end of the case; wherein the at least one mounting arm is mounted on the mounting portion of the case; and wherein the lid is connected to the case to cover the open end of the case.

**22.** A quartz crystal oscillator according to claim **21**; wherein the groove is formed in the at least one of the first and second main surfaces of the first vibrational portion of each of the first and second vibrational arms so that a distance in the width direction of the groove measured from an outer edge of the groove to an outer edge of the corresponding one of the first and second vibrational arms is less than 0.015 mm; and wherein each of the first spaced-apart distance  $W_{10}$  and the second spaced-apart distance  $W_{10}$  is within a range of 0.032 mm to 0.21 mm.

**23.** A quartz crystal oscillator according to claim **21**; wherein the width  $W_{11}$  of the at least one mounting arm has a value of  $(1.2 \text{ to } 7.6) \times W$ , where  $W$  represents the first width of the first vibrational portion of each of the first and second vibrational arms.

**24.** An electronic apparatus comprising:

a display portion;

and at least one quartz crystal oscillator having a quartz crystal oscillating circuit comprised of a quartz crystal unit having a quartz crystal resonator including a base portion, and first and second vibrational arms connected to the base portion, each of the first and second vibrational arms having opposite main surfaces;

wherein at least one groove is formed in at least one of the opposite main surfaces of each of the first and second vibrational arms;

wherein a length of the base portion is less than 0.5 mm and an overall length of the quartz crystal resonator is less than 2.1 mm;

wherein at least one mounting arm protrudes from the base portion and is formed between the first and second vibrational arms, the at least one mounting arm extending in a common direction with the first and second vibrational arms; and

wherein an output signal of the at least one quartz crystal oscillator is a clock signal for use in operation of the electronic apparatus to display time information at the display portion.

**25.** An electronic apparatus according to claim **24**; wherein each of the first and second vibrational arms comprises a first vibrational portion having a first width  $W$  and a second vibrational portion having a second width  $W_e$  greater than the first width  $W$ , the first vibrational portion of each of the first and second vibrational arms having a first main surface and a second main surface opposite the first main surface; wherein the at least one groove comprises a groove formed in each of the first and second main surfaces of the first vibrational portion of each of the first and second vibrational arms so that a width of the groove formed in each of the first and second main surfaces of the first vibrational portion of each of the first and second vibrational arms is less than 0.07 mm; wherein each of a first spaced-apart distance between the first vibrational arm and the at least one mounting arm and a second spaced-apart distance between the second vibrational arm and the at least one mounting arm is defined by  $W_{10}$ ; wherein the at least one mounting arm has a width  $W_{11}$ ; wherein a width  $W_z$  is defined by  $(2W + 2W_{10} + W_{11})$ ; wherein the width  $W_z$  is less than 1.3 mm; wherein the length of the base portion is within a range of 0.015 mm to 0.49 mm; wherein the at least one mounting arm has first and second arm portions; wherein a first electrode is disposed on a surface of the first arm portion of the at least one mounting arm and a second electrode is disposed on a surface of the second arm portion of the at least one mounting arm; wherein a third electrode is disposed on a surface of the groove formed in each of the first and second main surfaces of the first vibrational portion of each of the first and second vibrational arms; wherein the first electrode disposed on the surface of the first arm portion of the at least one mounting arm is electrically connected to the third electrode disposed on the surface of the groove formed in each of the first and second main surfaces of the first vibrational portion of the first vibrational arm, and the second electrode disposed on the surface of the second arm portion of the at least one mounting arm is electrically connected to the third electrode disposed on the surface of the groove formed in each of the first and second main surfaces of the first vibrational portion of the second vibrational arm; and further comprising a case having a mounting portion and a lid for covering an open end of the case; wherein the at least one mounting arm is mounted on the mounting portion of the case; and wherein the lid is connected to the case to cover the open end of the case.

**26.** An electronic apparatus according to claim **25**; wherein a distance in the width direction of the groove measured from an outer edge of the groove to an outer edge of the corresponding one of the first and second vibrational arms is less than 0.015 mm.

**27.** An electronic apparatus according to claim **25**; wherein at least one of the first spaced-apart distance  $W_{10}$  and the second spaced-apart distance  $W_{10}$  is within a range of 0.032 mm to 0.21 mm.

**28.** An electronic apparatus according to claim **24**; wherein the quartz crystal resonator comprises a quartz crystal tuning fork resonator having a quartz crystal tuning fork base, and first and second quartz crystal tuning fork arms connected to the quartz crystal tuning fork base, wherein a length of the quartz crystal tuning fork base is within a range of 0.015 mm to 0.49 mm and an overall length of the quartz crystal tuning fork resonator is less than 2.1 mm; wherein each of first and second quartz crystal tuning fork arms has a width  $W$ ; wherein the at least one mounting arm comprises a mounting arm connected to the quartz crystal tuning fork base and formed between the first and second quartz crystal tuning fork arms, the mounting arm extending in a common direction with the first and second quartz crystal tuning fork arms; wherein each of a first spaced-apart distance between the first quartz crystal tuning fork arm and the mounting arm and a second spaced-apart distance between the second quartz crystal tuning fork arm and the mounting arm is defined by  $W_{10}$ ; wherein the mounting arm has a width  $W_{11}$ ; wherein a width  $W_z$  is defined by  $(2W + 2W_{10} + W_{11})$ ; wherein the width  $W_z$  is less than 1.3 mm; and further comprising a case having a mounting portion and a lid for covering an open end of the case; wherein the mounting arm is mounted on the mounting portion of the case; and wherein the lid is connected to the case to cover the open end of the case.

**29.** An electronic apparatus according to claim **28**; wherein each of first and second quartz crystal tuning fork arms has a first main surface and a second main surface opposite the first main surface; and wherein the at least one groove comprises a groove formed in at least one of the first and second main surfaces of each of the first and second quartz crystal tuning fork arms so that a width of the groove formed in the at least one of the first and second main surfaces of each of the first and second quartz crystal tuning fork arms is less than 0.07 mm and a distance in the width direction of the groove measured from an outer edge of the groove to an outer edge of the corresponding one of the first and second quartz crystal tuning fork arms is less than 0.015 mm.

**30.** An electronic apparatus according to claim **28**; wherein the width  $W_{11}$  has a value of  $(1.2 \text{ to } 7.6) \times W$ , where  $W$  represents the width of each of first and second quartz crystal tuning fork arms.

**31.** An electronic apparatus according to claim **28**; wherein the width  $W$  of each of first and second quartz crystal tuning fork arms is greater than 0.05 mm and less than 0.1 mm; wherein each of the first and second quartz crystal tuning fork arms comprises a first vibrational portion having a first width  $W$  and a second vibrational portion having a second width  $W_e$  greater than the first width  $W$ , the first vibrational portion of each of the first and second quartz crystal tuning fork arms having a first main surface and a second main surface opposite the first main surface; and wherein the at least one groove comprises a groove formed in at least one of the first and second main surfaces of the first vibrational portion of each of the first and second quartz crystal tuning fork arms so that a width of the groove formed in the at least one of the first and second main surfaces of the first vibrational portion of each of the first and second quartz crystal tuning fork arms is less than 0.07 mm and a length of the groove having the width less than 0.07 mm is within a range of 0.45 mm to 1.25 mm.

**32.** An electronic apparatus according to claim **24**; wherein the quartz crystal resonator comprises a quartz crystal tuning fork resonator having a quartz crystal tuning fork base, and first and second quartz crystal tuning fork arms connected to the quartz crystal tuning fork base, each of the first and second quartz crystal tuning fork arms comprising a plurality of vibrational portions having a first vibrational portion including a first width  $W$  and a second vibrational portion including a second width  $W_e$  greater than the first width  $W$ , the first vibrational portion of each of the first and second quartz crystal tuning fork arms having a first main surface and a second main surface opposite the first main surface; wherein the at least one groove comprises a groove formed in each of the first and second main surfaces of the first vibrational portion of each of the first and second quartz crystal tuning fork arms so that a width of the groove formed in each of the first and second main surfaces of the first vibrational portion of each of the first and second quartz crystal tuning fork arms is less than 0.07 mm; wherein a length of the quartz crystal tuning fork base is within a range of 0.015 mm to 0.49 mm and an overall length of the quartz crystal tuning fork resonator is less than 2.1 mm; wherein the at least one mounting arm comprises a mounting arm connected to the quartz crystal tuning fork base and formed between the first and second quartz crystal tuning fork arms, the mounting arm extending in a common direction with the first and second quartz crystal tuning fork arms; wherein each of a first spaced-apart distance between the first quartz crystal tuning fork arm and the mounting arm and a second spaced-apart distance between the second quartz crystal tuning fork arm and the mounting arm is defined by  $W_{10}$ ; wherein the mounting arm has a width  $W_{11}$ ; wherein a width  $W_r$  is defined by  $(2W + 2W_{10} + W_{11})$ ; wherein the width  $W_r$  is less than 1.3 mm; wherein the width  $W_{11}$  has a value of  $(1.2 \text{ to } 7.6) \times W$ ; wherein at least one of the first spaced-apart distance  $W_{10}$  and the second spaced-apart distance  $W_{10}$  is within a range of 0.032 mm to 0.21 mm; and further comprising a case having a mounting portion and a lid for covering an open end of the case; wherein the mounting arm is mounted on the mounting portion of the case; and wherein the lid is connected to the case to cover the open end of the case.

**33.** An electronic apparatus according to claim **24**; wherein the quartz crystal resonator comprises a quartz crystal tuning fork resonator having a quartz crystal tuning fork base, and first and second quartz crystal tuning fork arms connected to the quartz crystal tuning fork base; wherein a length of the quartz crystal tuning fork base is within a range of 0.015 mm to 0.49 mm and an overall length of the quartz crystal tuning fork resonator is less than 2.1 mm, each of the first and second quartz crystal tuning fork arms having a first main surface and a second main surface opposite the first main surface; wherein the at least one groove comprises a plurality of grooves having a first groove and a second groove formed in at least one of the first and second main surfaces of each of the first and second quartz crystal tuning fork arms; wherein each of the first and second grooves formed in the at least one of the first and second main surfaces of each of the first and second quartz crystal tuning fork arms has a first outer edge and a second outer edge opposite the first outer edge in the width direction, a distance in the width direction of the first and second grooves measured from the first outer edge of the first groove to the first outer edge of the second groove being defined by  $W_7$ ; wherein the distance  $W_7$  is less than 0.05 mm; wherein the at least one mounting arm comprises a mounting

arm connected to the quartz crystal tuning fork base and formed between the first and second quartz crystal tuning fork arms, the mounting arm extending in a common direction with the first and second quartz crystal tuning fork arms; and further comprising a case having a mounting portion and a lid for covering an open end of the case; wherein the mounting arm is mounted on the mounting portion of the case; and wherein the lid is connected to the case to cover the open end of the case.

**34.** An electronic apparatus according to claim **33**; wherein each of the first and second quartz crystal tuning fork arms has a first outer edge and a second outer edge opposite the first outer edge in the width direction; wherein each of the first and second grooves formed in the at least one of the first and second main surfaces of each of the first and second quartz crystal tuning fork arms has a width  $W_8$ ; wherein the width  $W_8$  of the first groove is greater than or equal to a distance  $W_9$  in the width direction of the first groove measured from the second outer edge of the first groove to the first outer edge of the corresponding one of the first and second quartz crystal tuning fork arms; and wherein the width  $W_8$  of the second groove is greater than or equal to a distance  $W_9$  in the width direction of the second groove measured from the second outer edge of the second groove to the second outer edge of the corresponding one of the first and second quartz crystal tuning fork arms.

**35.** An electronic apparatus according to claim **24**; wherein the at least one oscillator comprises a first oscillator having a first oscillating circuit including a first resonator and a second oscillator having a second oscillating circuit including a second resonator; wherein the first resonator of the first oscillating circuit comprises one of a quartz crystal thickness shear mode resonator, a resonator for sensing an angular velocity and a SAW resonator; wherein an output signal of the first oscillating circuit is a clock signal for use in operation of the electronic apparatus; wherein the second resonator of the second oscillating circuit comprises a quartz crystal tuning fork resonator having a quartz crystal tuning fork base, and first and second quartz crystal tuning fork arms connected to the quartz crystal tuning fork base, each of the first and second quartz crystal tuning fork arms comprising a plurality of vibrational portions having a first vibrational portion including a first width  $W$  and a second vibrational portion including a second width  $W_e$  greater than the first width  $W$ , the first vibrational portion of each of the first and second quartz crystal tuning fork arms having a first main surface and a second main surface opposite the first main surface; wherein the at least one groove comprises a groove formed in each of the first and second main surfaces of the first vibrational portion of each of the first and second quartz crystal tuning fork arms so that a width of the groove formed in each of the first and second main surfaces of the first vibrational portion of each of the first and second quartz crystal tuning fork arms is less than 0.07 mm; wherein a length of the quartz crystal tuning fork base is within a range of 0.015 mm to 0.49 mm and an overall length of the quartz crystal tuning fork resonator is less than 2.1 mm; wherein the at least one mounting arm comprises a mounting arm connected to the quartz crystal tuning fork base and formed between the first and second quartz crystal tuning fork arms, the mounting arm extending in a common direction with the first and second quartz crystal tuning fork arms; wherein each of a first spaced-apart distance between the first quartz crystal tuning fork arm and the mounting arm and a second spaced-apart distance between

the second quartz crystal tuning fork arm and the mounting arm is defined by  $W_{10}$ ; wherein the mounting arm has a width  $W_{11}$ ; wherein a width  $W_z$  is defined by  $(2 W_z + 2 W_{10} + W_{11})$ ; wherein the width  $W_z$  is less than 1.3 mm; wherein at least one of the first spaced-apart distance  $W_{10}$  and the second spaced-apart distance  $W_{10}$  is within a range of 0.032 mm to 0.21 mm; and further comprising a case having a mounting portion and a lid for covering an open end of the case; wherein the mounting arm is mounted on the mounting portion of the case; wherein the lid is connected to the case to cover the open end of the case; and wherein an output signal of the second oscillating circuit comprising the quartz crystal tuning fork resonator is a clock signal for use in operation of the electronic apparatus to display time information at the display portion.

\* \* \* \* \*