



US 2024022888A1

(19) **United States**

(12) **Patent Application Publication**
Bitting et al.

(10) **Pub. No.: US 2024/0228888 A1**

(43) **Pub. Date: Jul. 11, 2024**

(54) **BLEND SMALL AMOUNTS OF PYOIL INTO A LIQUID STREAM PROCESSED INTO A GAS CRACKER**

application No. PCT/US2020/034139 on May 22, 2020.

(60) Provisional application No. 62/852,371, filed on May 24, 2019.

(71) Applicant: **Eastman Chemical Company,**
Kingsport, TN (US)

(72) Inventors: **Daryl Bitting,** Longview, TX (US);
Kenny Randolph Parker, Afton, TN (US);
Michael Gary Polasek, Longview, TX (US);
David Eugene Slivensky, Tatum, TX (US);
Xianchun Wu, Longview, TX (US);
Jerome Leonard Stavinoha, JR., Longview, TX (US)

(73) Assignee: **Eastman Chemical Company,**
Kingsport, TN (US)

(21) Appl. No.: **18/610,557**

(22) Filed: **Mar. 20, 2024**

Related U.S. Application Data

(63) Continuation of application No. 17/595,512, filed on Nov. 18, 2021, now Pat. No. 11,946,000, filed as

Publication Classification

(51) **Int. Cl.**
C10G 3/00 (2006.01)
C10G 1/10 (2006.01)
(52) **U.S. Cl.**
CPC **C10G 3/40** (2013.01); **C10G 1/10** (2013.01); **C10G 2300/1003** (2013.01); **C10G 2300/301** (2013.01); **C10G 2400/20** (2013.01); **C10G 2400/22** (2013.01)

(57) **ABSTRACT**

A hydrocarbon cracker stream is combined with recycle content pyrolysis oil to form a combined cracker stream and the combined cracker stream is cracked in a cracker furnace to provide an olefin-containing effluent. The r-pyoil can be fed to the cracker feed. More specifically the-pyoil is present in said feedstock in an amount of not more than 20% by weight, based on the total weight of the feedstock.

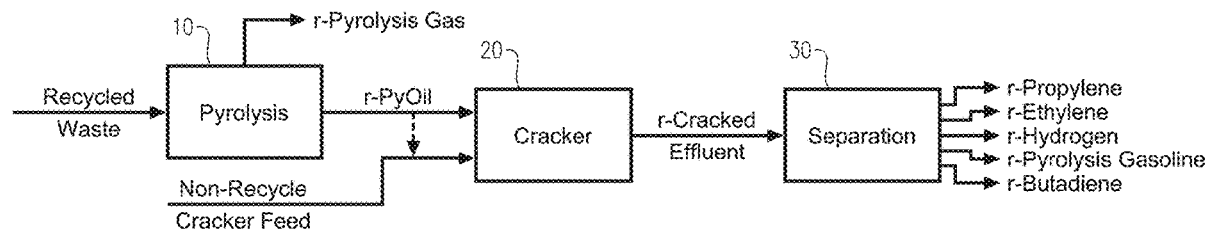

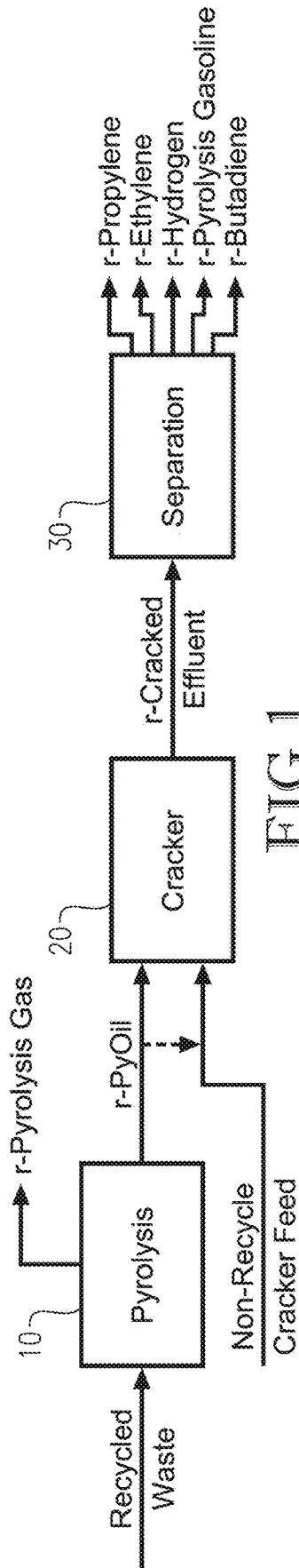

FIG. 1

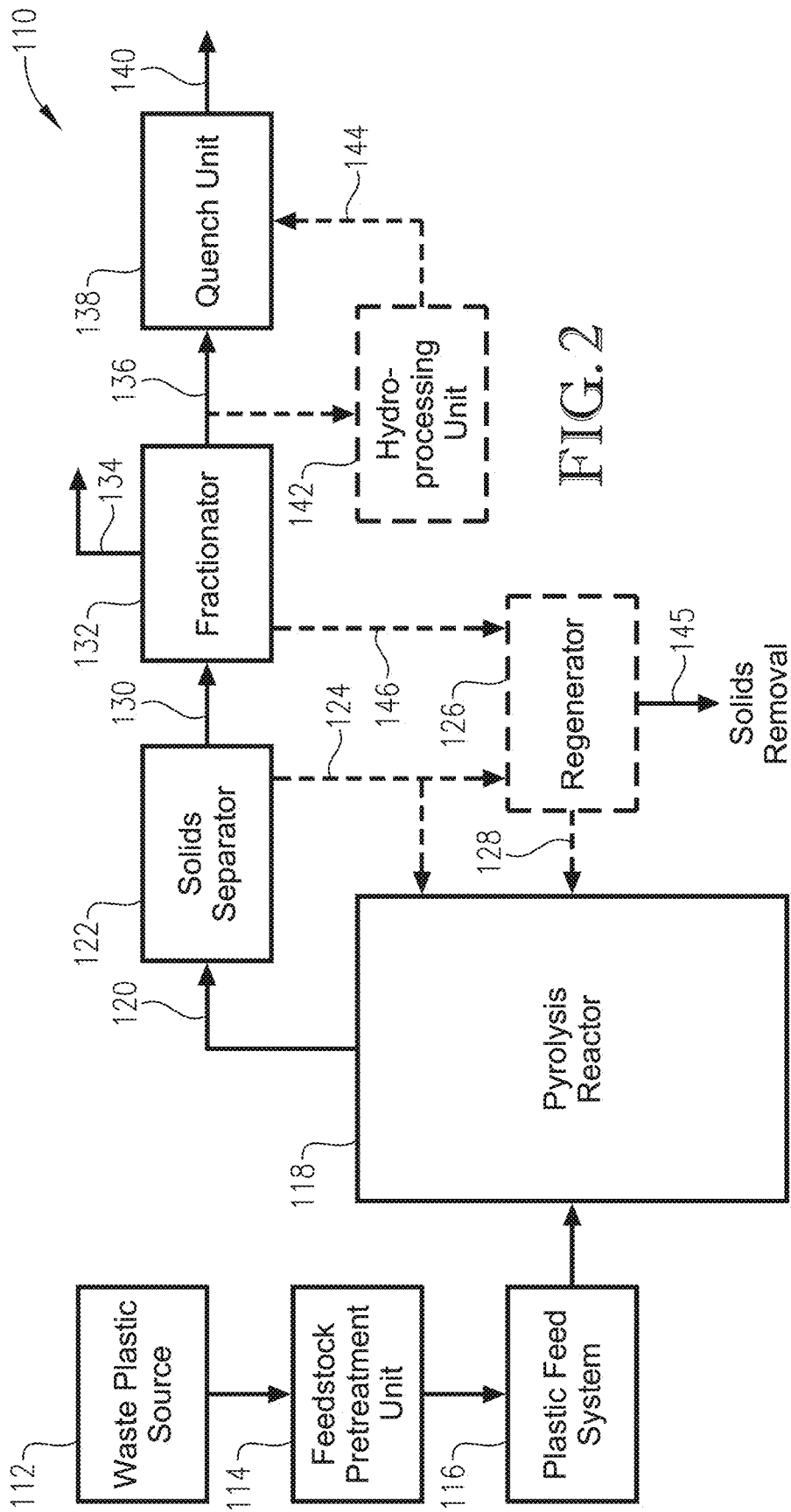

FIG. 2

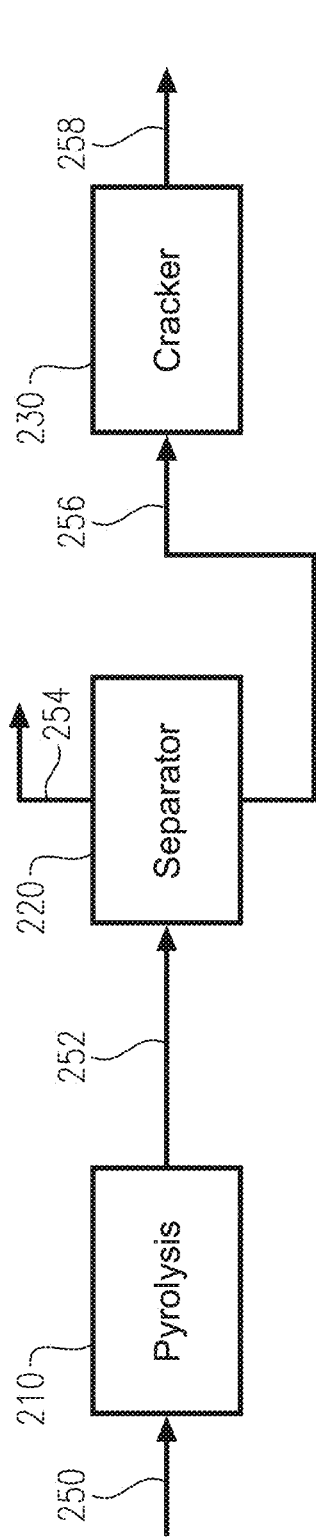

FIG. 3

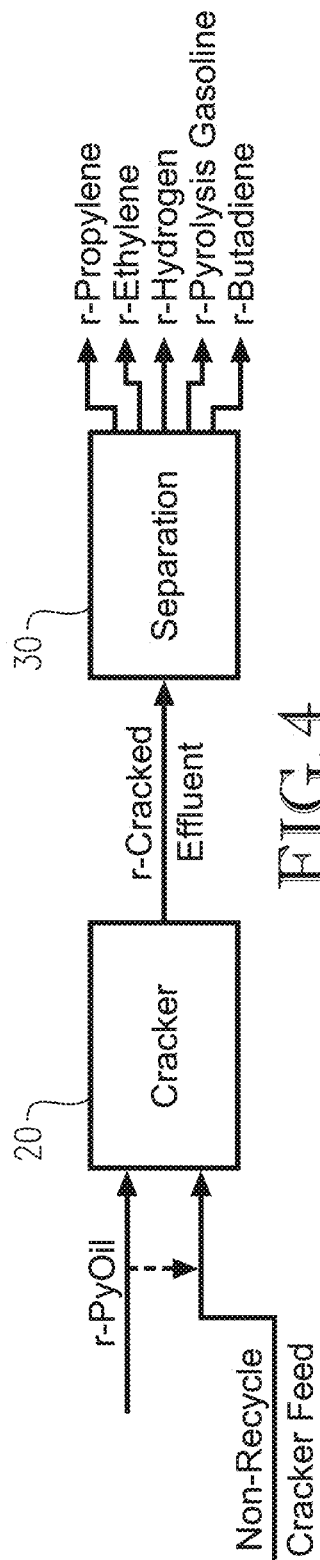

FIG. 4

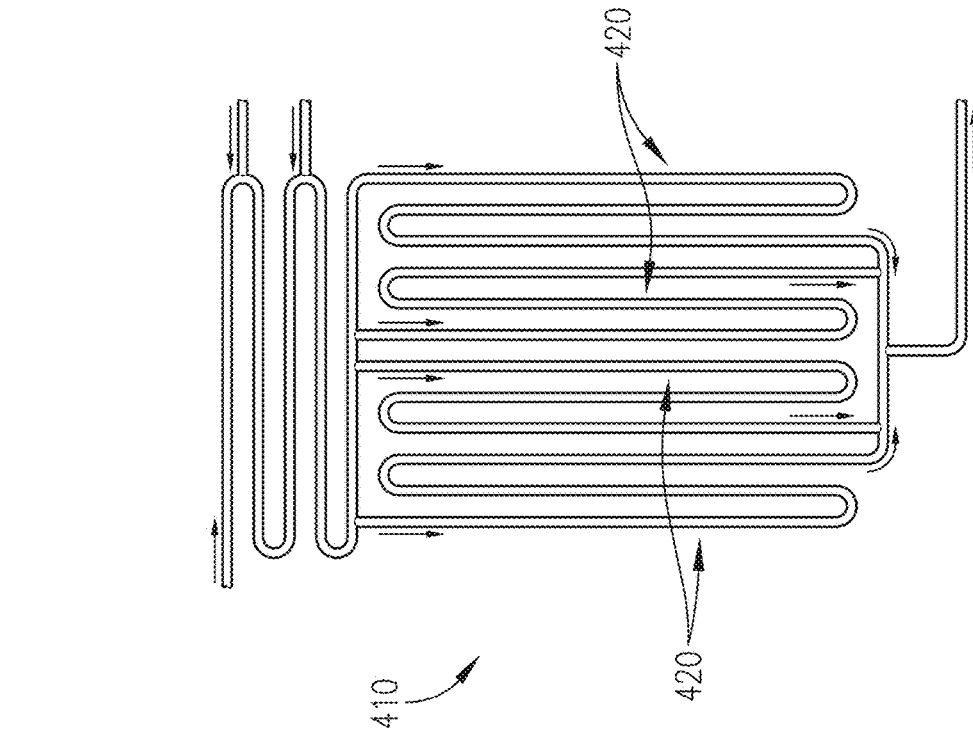

FIG. 6

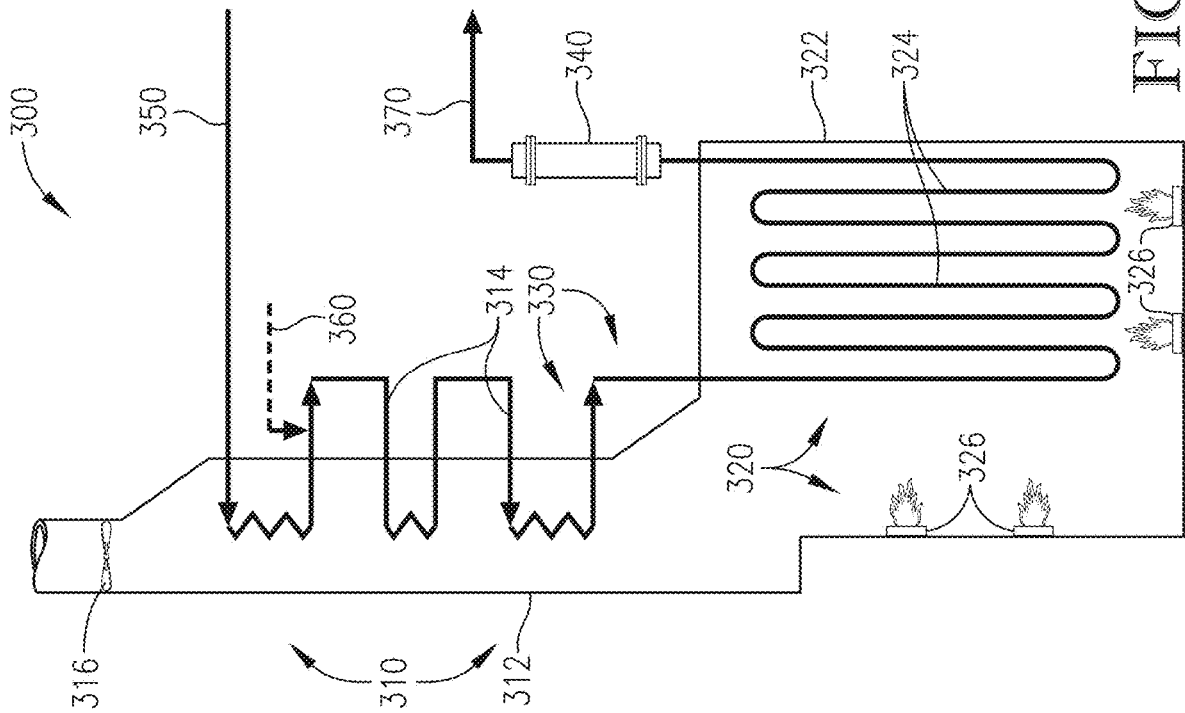
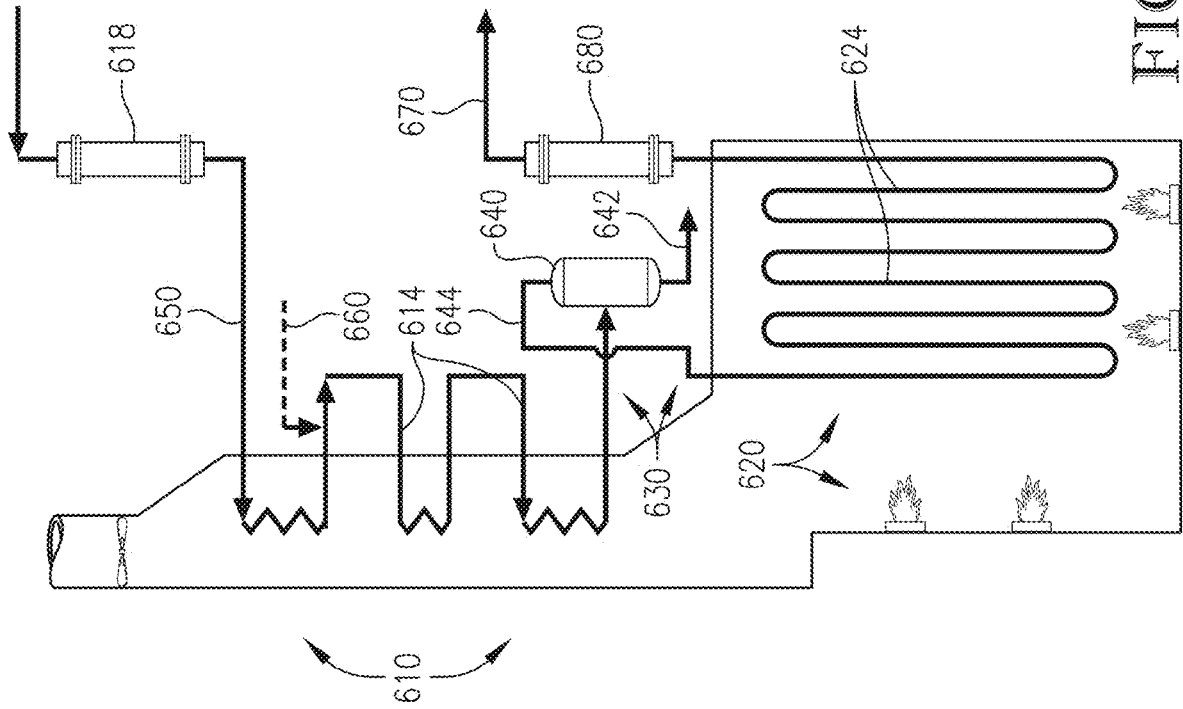
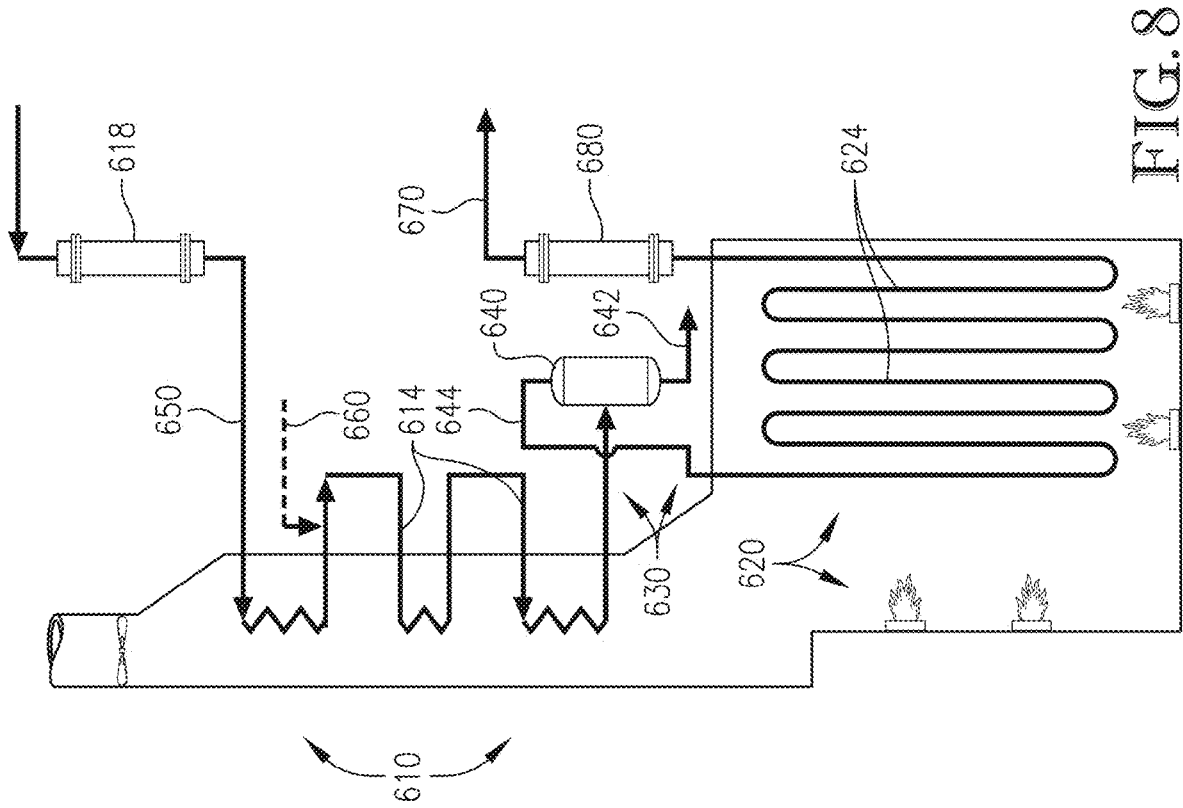

FIG. 5



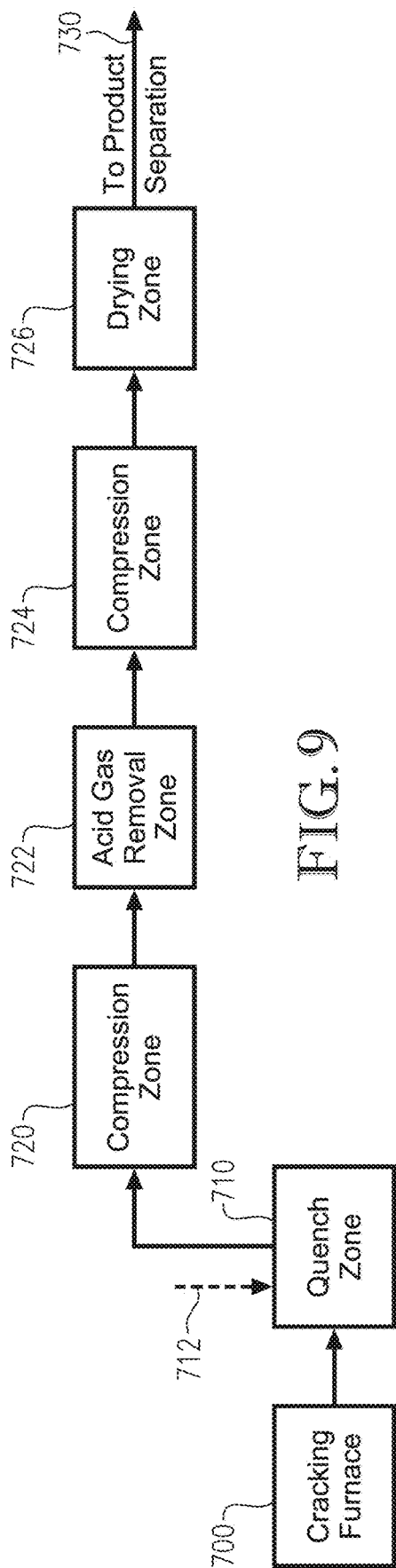

FIG. 9

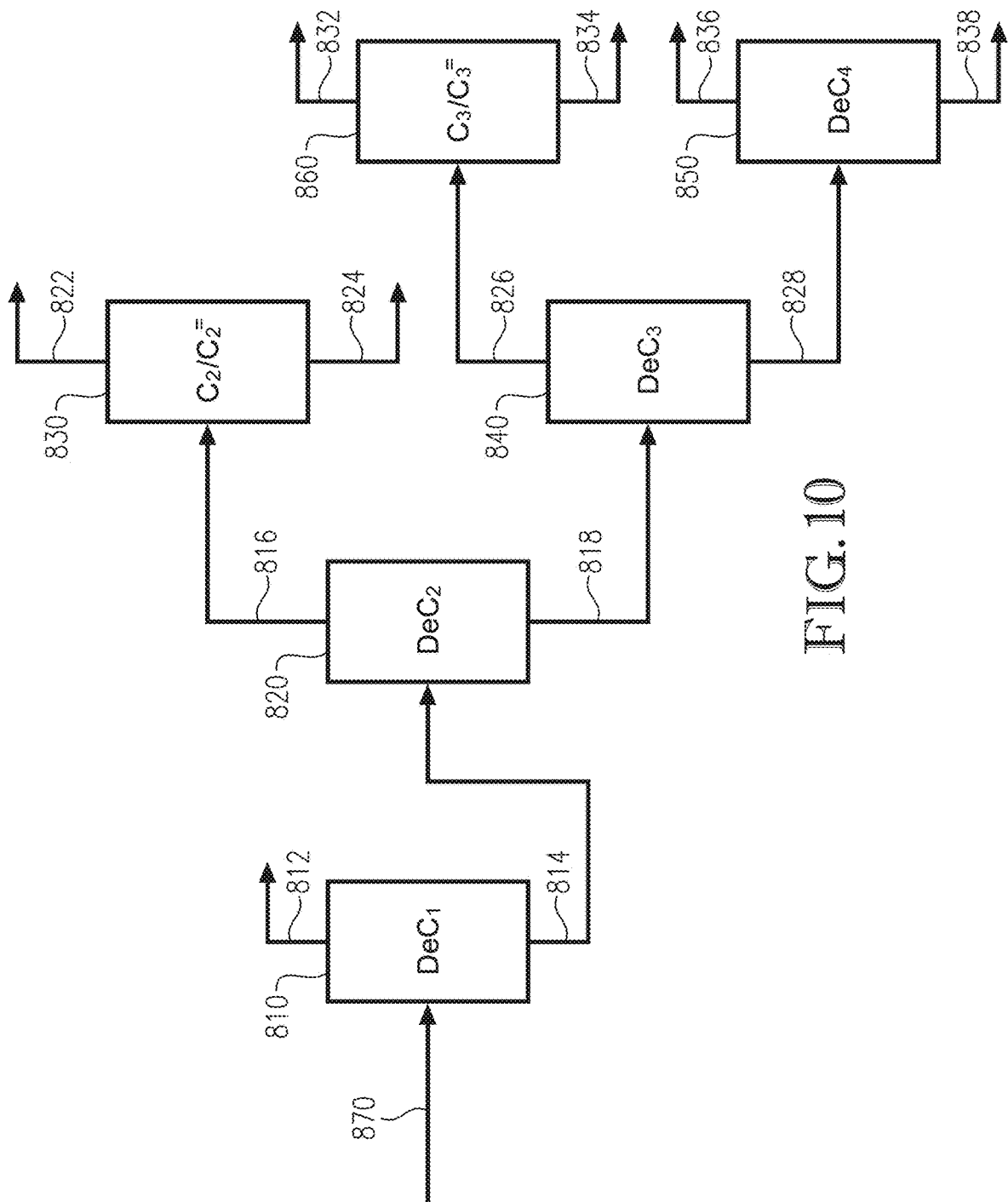

FIG. 10

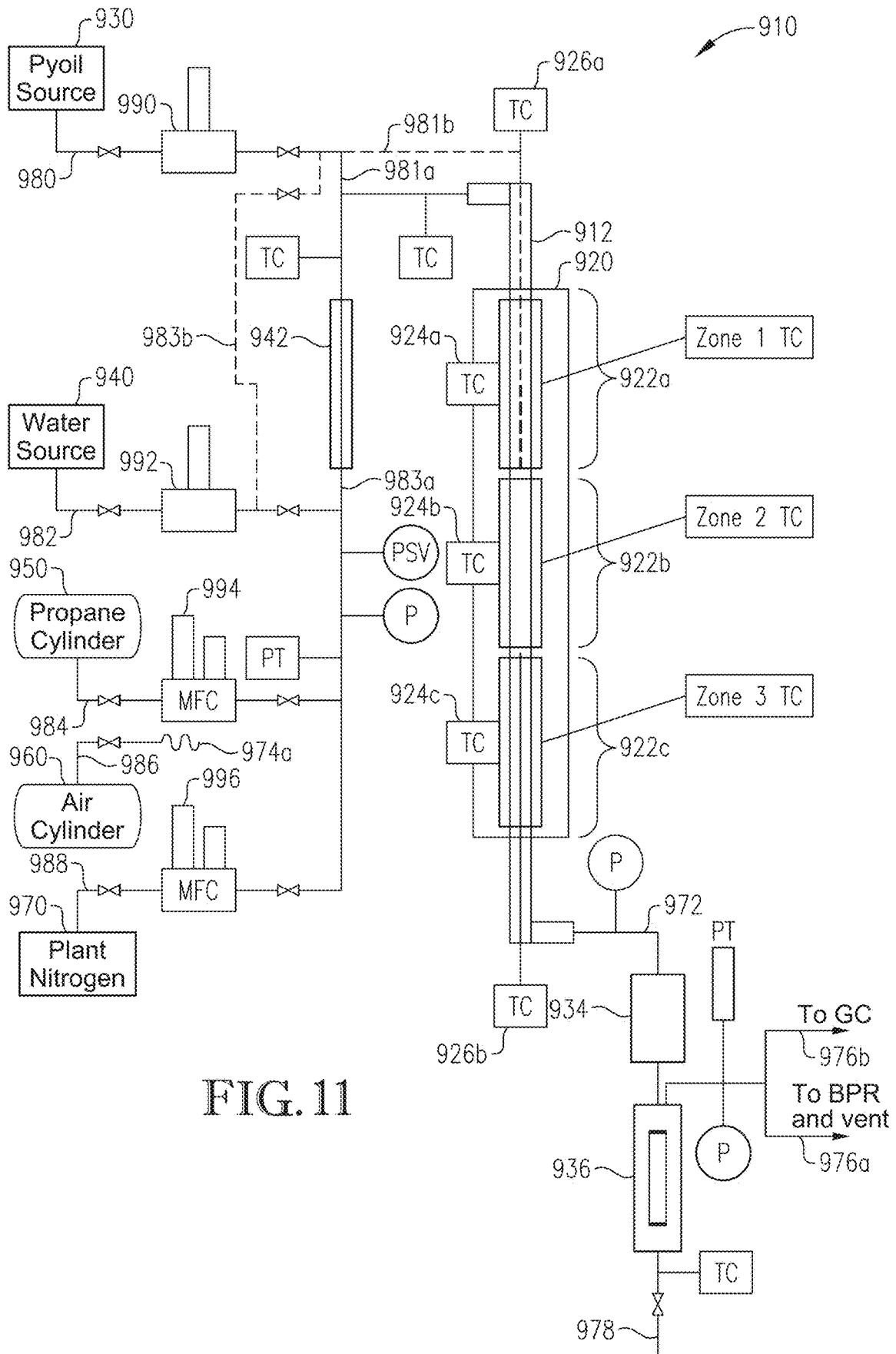

FIG. 11

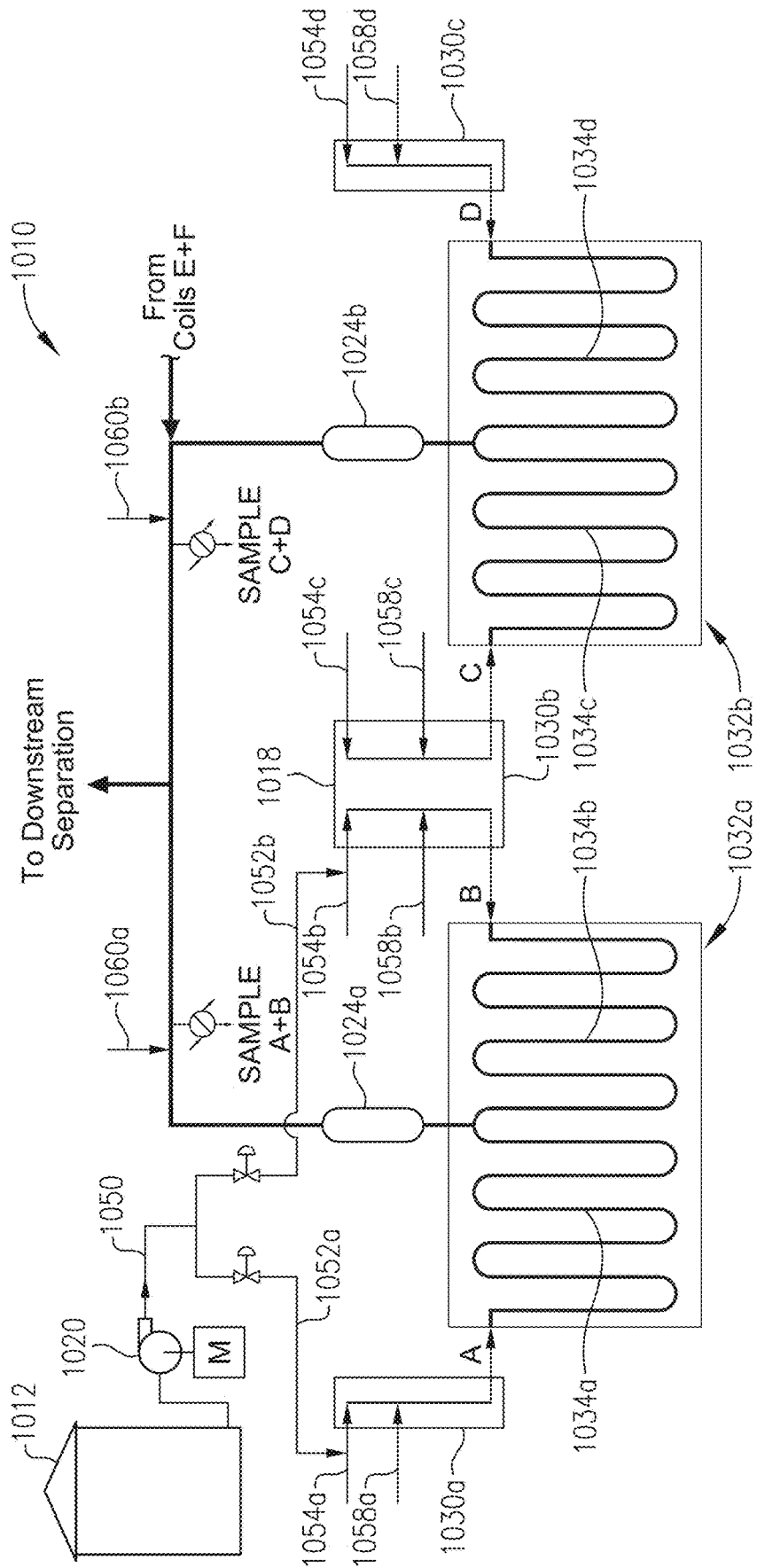

FIG. 12

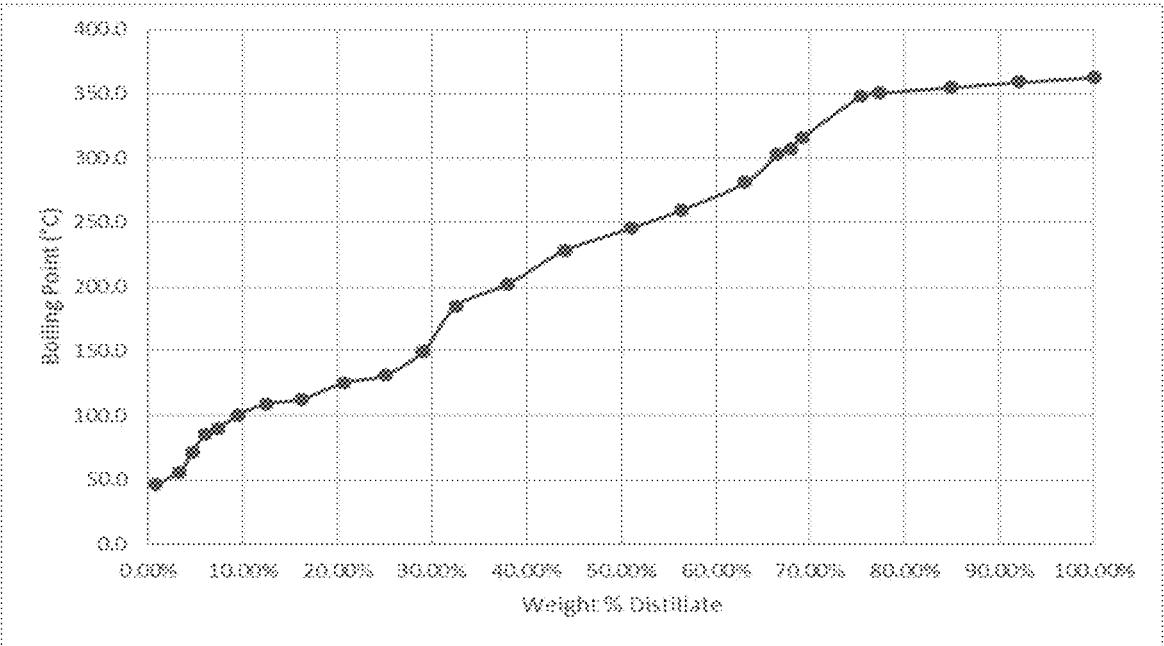

Figure 13

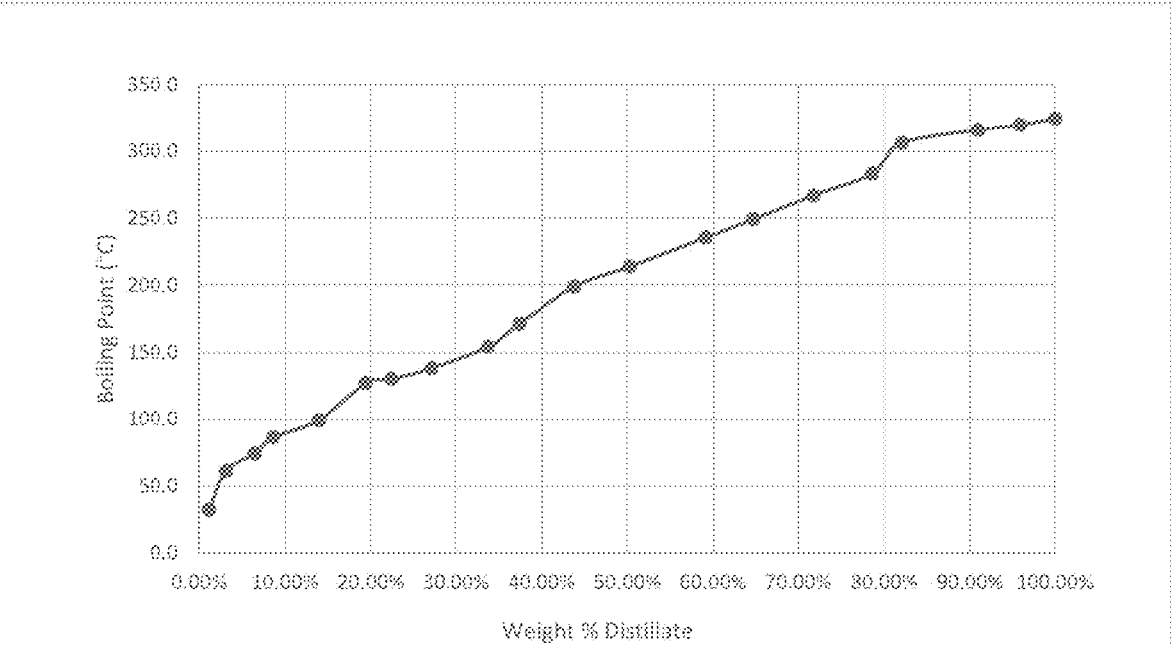

Figure 14

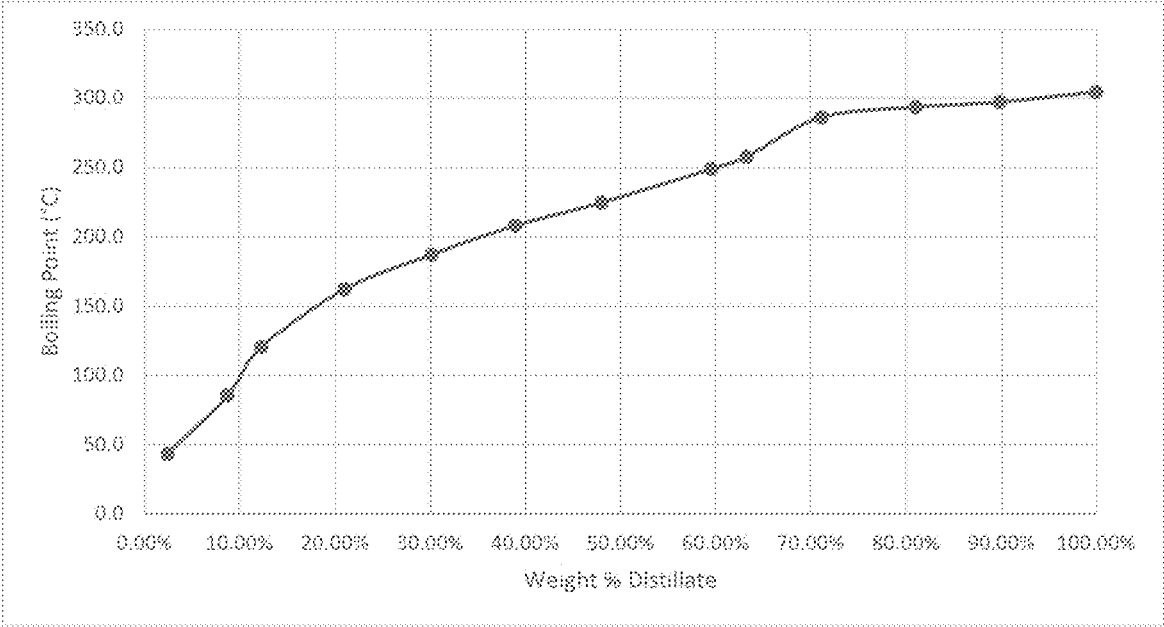

Figure 15

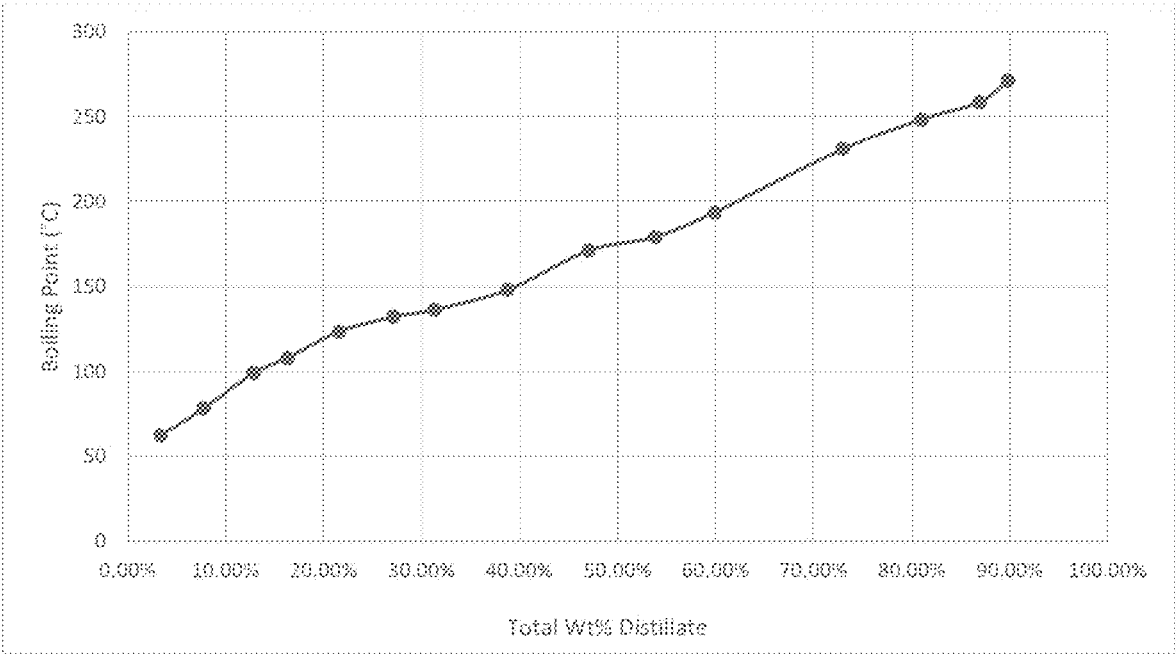

Figure 16

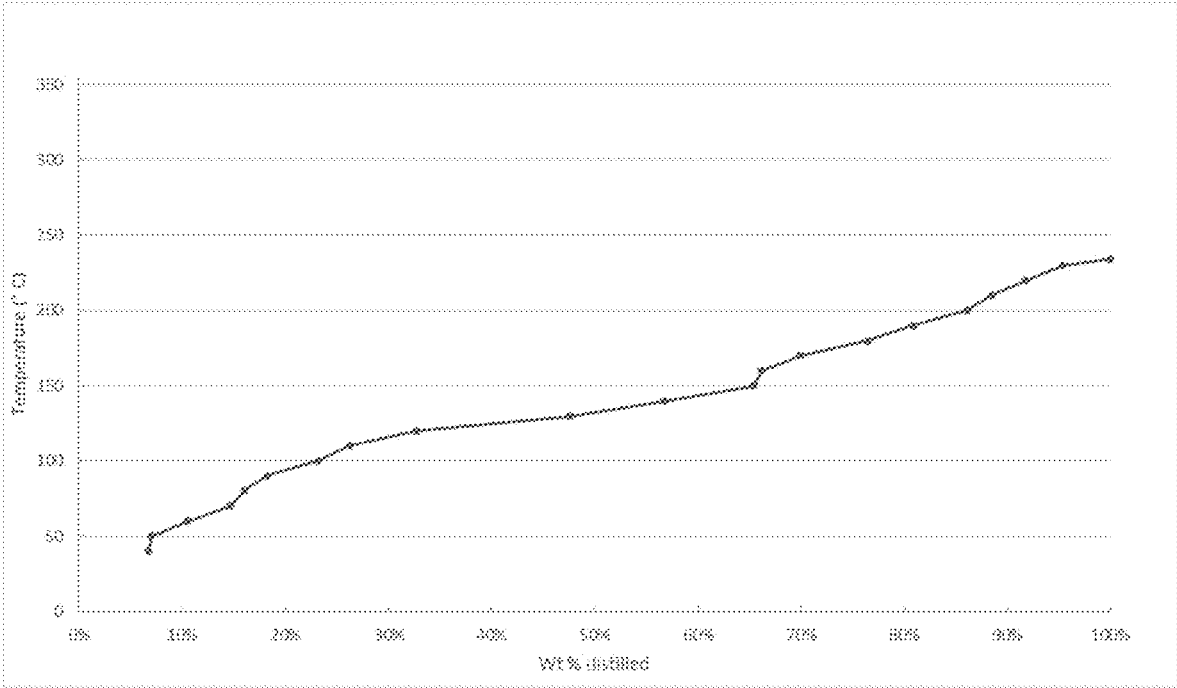

Figure 17

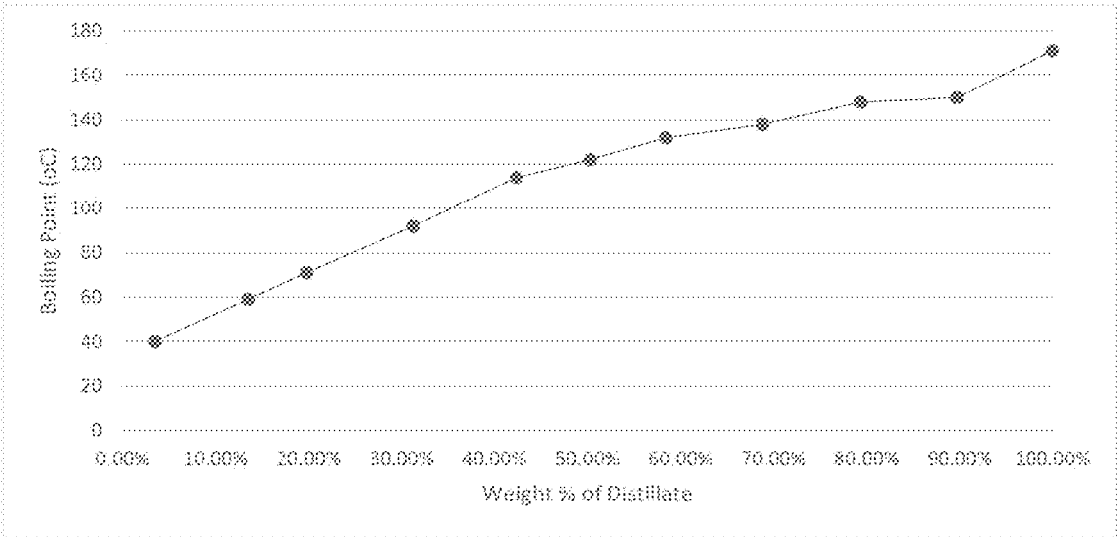

Figure 18

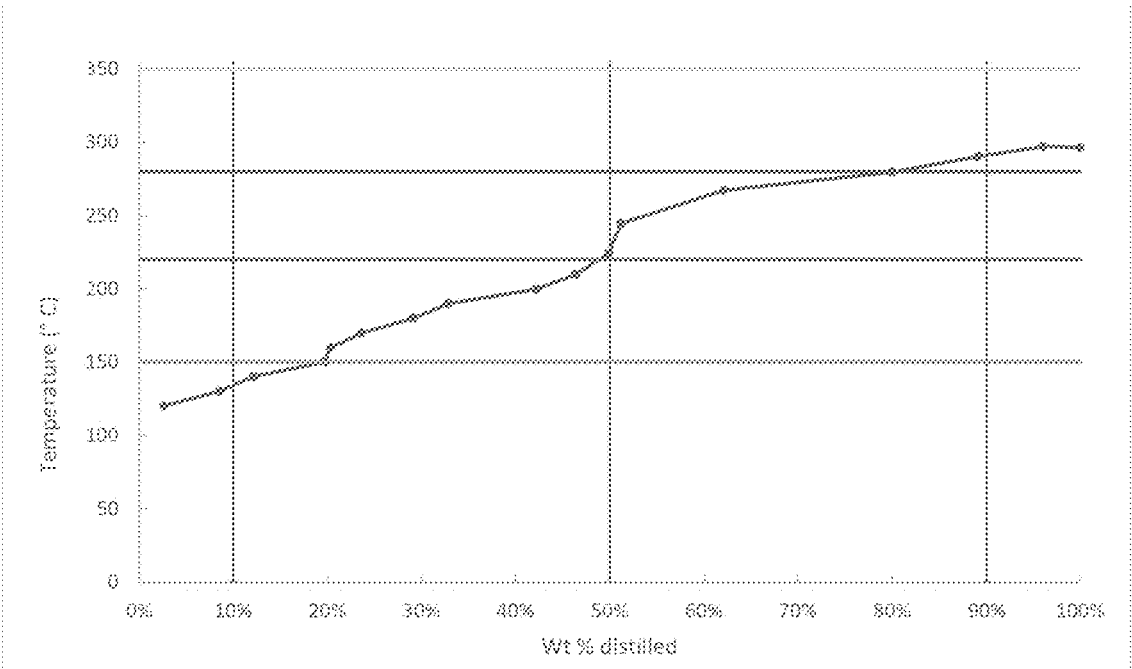

Figure 19

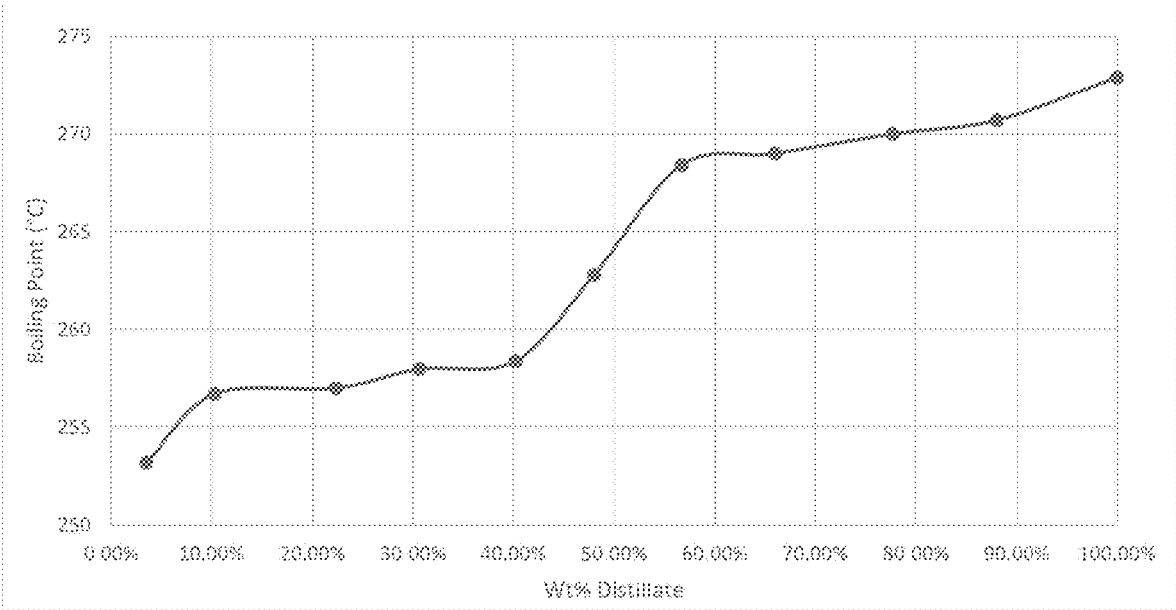

Figure 20

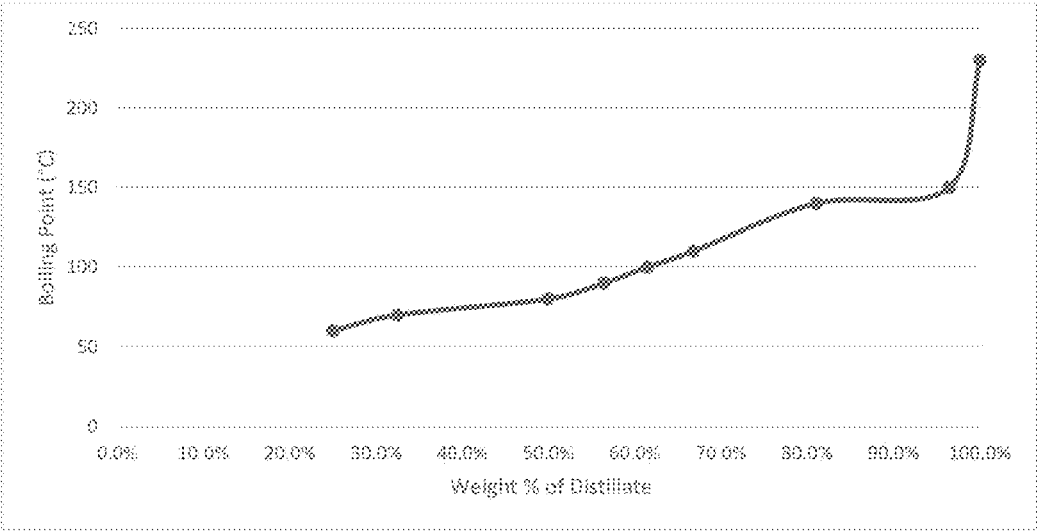

Figure 21

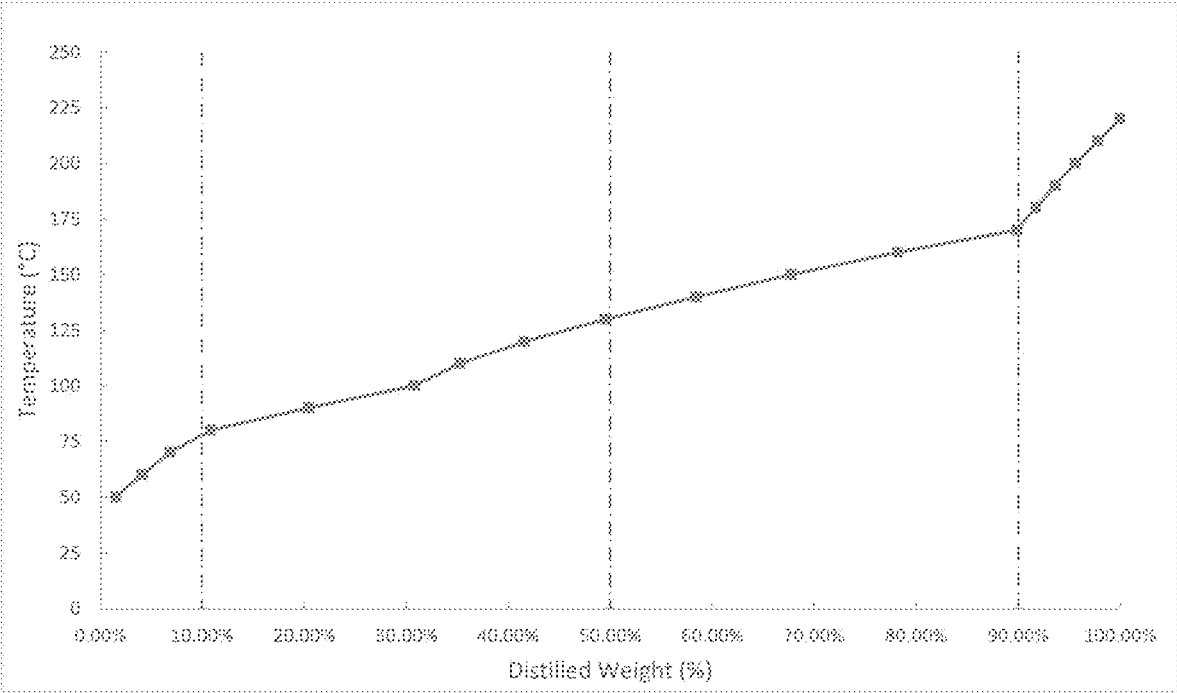

Figure 22

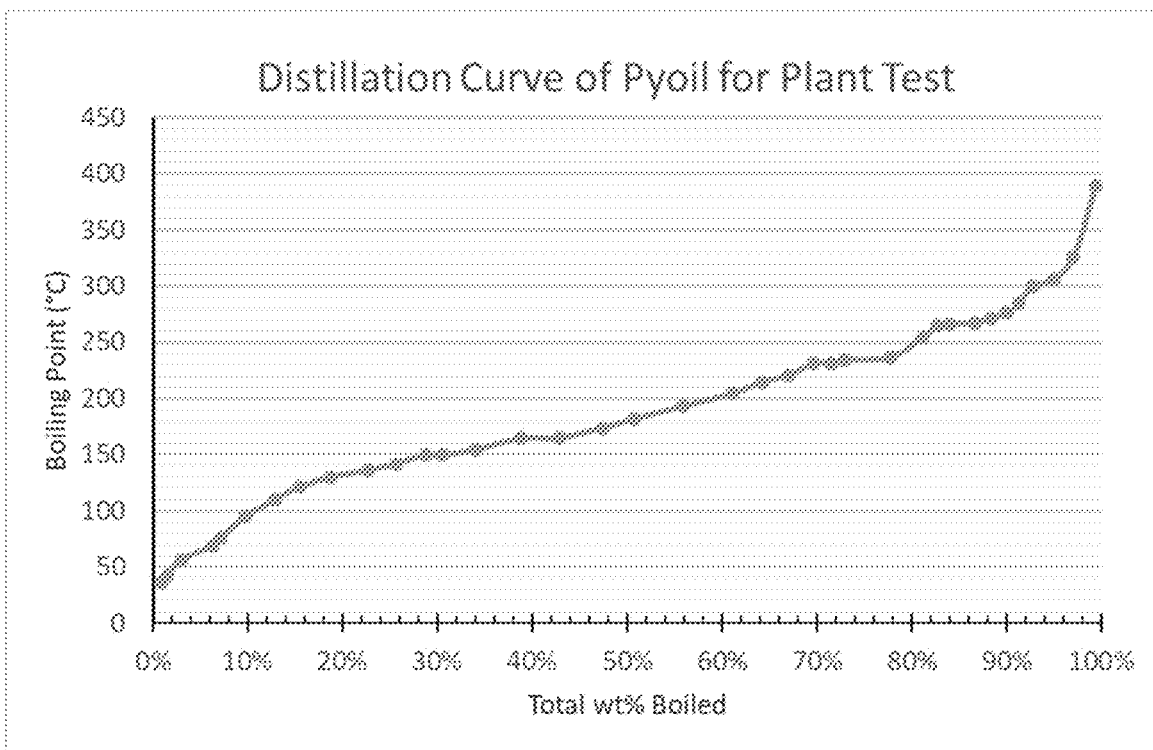

Figure 23

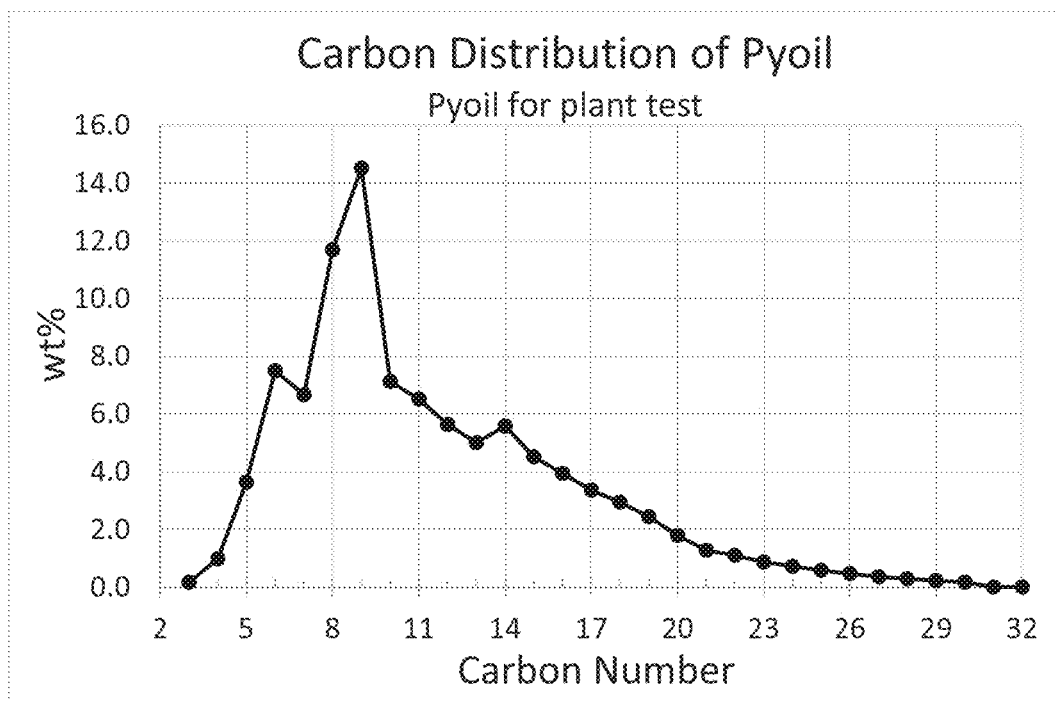

Figure 24

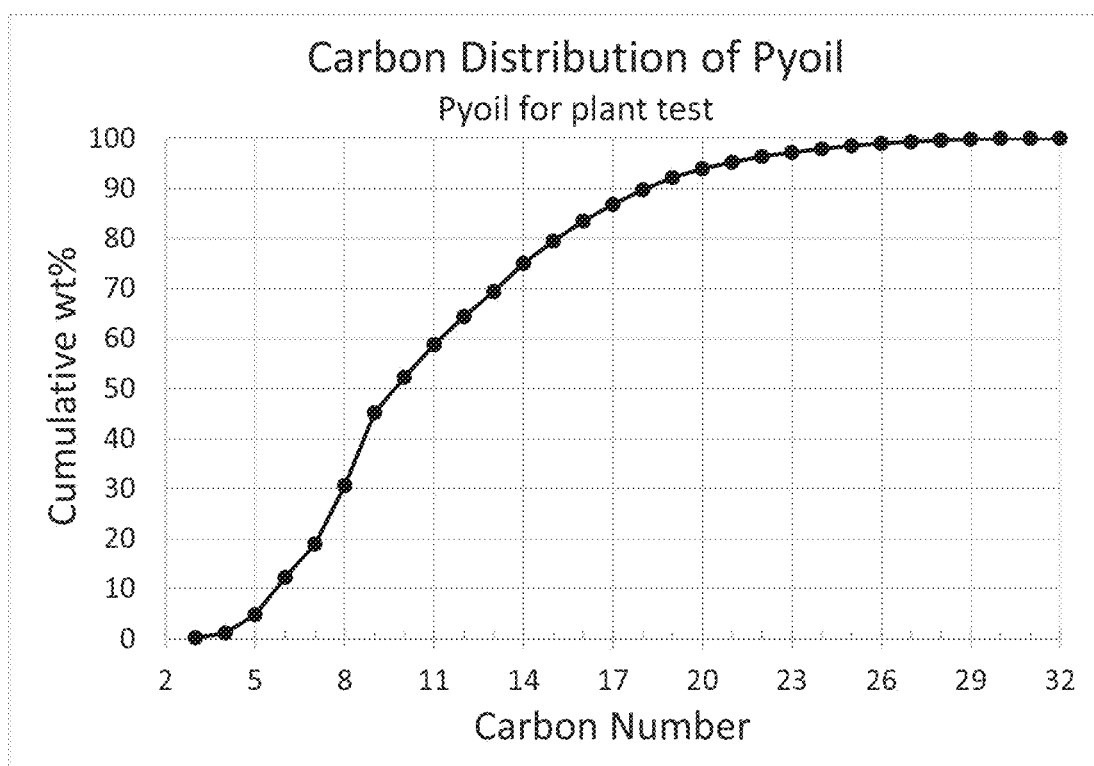

Figure 25

BLEND SMALL AMOUNTS OF PYOIL INTO A LIQUID STREAM PROCESSED INTO A GAS CRACKER

BACKGROUND

[0001] Waste materials, especially non-biodegradable waste materials, can negatively impact the environment when disposed of in landfills after a single use. Thus, from an environmental standpoint, it is desirable to recycle as much waste materials as possible. However, recycling waste materials can be challenging from an economic standpoint.

[0002] While some waste materials are relatively easy and inexpensive to recycle, other waste materials require significant and expensive processing in order to be reused. Further, different types of waste materials often require different types of recycling processes. In many cases, expensive physical sorting of waste materials into relatively pure, single-composition waste volumes is required.

[0003] To maximize recycling efficiency, it would be desirable for large-scale production facilities to be able to process feedstocks having recycle content originating from a variety of waste materials. Commercial facilities involved in the production of non-biodegradable products could benefit greatly from using recycle content feedstocks because the positive environmental impact of using recycle content feeds could offset the negative environmental impact of making non-biodegradable products.

[0004] A crude pyoil stream has a wide variety of carbon number and molecular weights. Crackers accept feeds typically having a fairly narrow range of carbon numbers and the operating conditions are tuned to process such standard feeds. The addition of pyoil to such feeds can be problematic in that heavier components in the pyoil can overcrack, foul, or coke the tubes and reduce the yields to olefins and service time. One technique is to separate the components of pyoil into fractions that more closely resemble the standard feedstock. However, separation equipment is costly and results in problems for use or disposal of the undesirable fraction. It would be desirable to add a pyoil stream to a liquid stream for cracking that leaves open the flexibility to fractionate or not fractionate the pyoil stream prior to cracking.

[0005] In addition, the availability of pyoil is in limited quantities, yet the demand to establish a recycle content in a variety of products continue to grow. It would be desirable to continuously feed a pyoil stream to a cracker without the necessity for campaigning the pyoil feed to establish a recycle content in the products.

SUMMARY

[0006] In certain embodiments, the present invention involves the large-scale production of one or more materials having recycle content. The recycle content of the products can originate from recycled waste and/or from recycle content pyrolysis oil (r-pyoil) produced via pyrolysis of recycled waste. In certain embodiments, a pyrolysis unit producing r-pyoil can be co-located with the production facility. In other embodiments, the r-pyoil can be sourced from a remote pyrolysis unit and transported to the production facility.

[0007] In certain embodiments, the present invention involves a cracker feedstock composition comprising a recycle content pyrolysis oil composition (r-pyoil), wherein

the r-pyoil is present in the feedstock in an amount of not more than 20% by weight, based on the total weight of the feedstock.

[0008] In certain embodiments, the present invention involves a method for making one or more olefins, comprising: (a) combining a recycle content pyrolysis oil composition (r-pyoil) with a non-recycle C5 to C22 hydrocarbon stream to form a cracker feed stream, wherein the r-pyoil is present in the cracker feed stream in an amount of not more than 20% by weight; and (b) cracking the cracker feed stream in a cracker furnace to provide an olefin-containing effluent stream.

[0009] In certain embodiments, the present invention involves a method for making olefins, comprising: (a) providing a recycle content pyrolysis oil composition (r-pyoil) having a first impurity content; (b) providing a C5 to C22 hydrocarbon composition; (c) combining the r-pyoil and the C5 to C22 hydrocarbon composition to provide a cracker feedstock composition, wherein the cracker feedstock composition has a final impurity content at least 50 percent lower than the first impurity content; and (d) cracking a cracker feed stream comprising at least a portion of the cracker feedstock in a cracking furnace to provide an olefin-containing effluent stream.

BRIEF DESCRIPTION OF THE DRAWINGS

[0010] FIG. 1 is an illustration of a process for employing a recycle content pyrolysis oil composition (r-pyoil) to make one or more recycle content compositions into r-compositions.

[0011] FIG. 2 is an illustration of an exemplary pyrolysis system to at least partially convert one or more recycled waste, particularly recycled plastic waste, into various useful r-products.

[0012] FIG. 3 is a schematic depiction of pyrolysis treatment through production of olefin containing products.

[0013] FIG. 4 is a block flow diagram illustrating steps associated with the cracking furnace and separation zones of a system for producing an r-composition obtained from cracking r-pyoil and non-recycle cracker feed.

[0014] FIG. 5 is a schematic diagram of a cracker furnace suitable for receiving r-pyoil.

[0015] FIG. 6 illustrates a furnace coil configuration having multiple tubes.

[0016] FIG. 7 illustrates a variety of feed locations for r-pyoil into a cracker furnace.

[0017] FIG. 8 illustrates a cracker furnace having a vapor-liquid separator.

[0018] FIG. 9 is a block diagram illustrating the treatment of a recycle content furnace effluent.

[0019] FIG. 10 illustrates a fractionation scheme in a Separation section, including a demethanizer, deethanizer, depropanizer, and the fractionation columns to separate and isolate the main r-compositions, including r-propylene, r-ethylene, r-butylene, and others.

[0020] FIG. 11 illustrates the laboratory scale cracking unit design.

[0021] FIG. 12 illustrates design features of a plant-based trial feeding r-pyoil to a gas fed cracker furnace.

[0022] FIG. 13 is a graph of the boiling point curve of a r-pyoil having 74.86% C8+, 28.17% C15+, 5.91% aromatics, 59.72% paraffins, and 13.73% unidentified components by gas chromatography analysis.

[0023] FIG. 14 is a graph of the boiling point curve of a r-pyoil obtained by gas chromatography analysis.

[0024] FIG. 15 is a graph of the boiling point curve of a r-pyoil obtained by gas chromatography analysis.

[0025] FIG. 16 is a graph of the boiling point curve of a r-pyoil distilled in a lab and obtained by chromatography analysis.

[0026] FIG. 17 is a graph of the boiling point curve of r-pyoil distilled in lab with at least 90% boiling by 350° C., 50% boiling between 95° C. and 200° C., and at least 10% boiling by 60° C.

[0027] FIG. 18 is a graph of the boiling point curve of r-pyoil distilled in lab with at least 90% boiling by 150° C., 50% boiling between 80° C. and 145° C., and at least 10% boiling by 60° C.

[0028] FIG. 19 is a graph of the boiling point curve of r-pyoil distilled in lab with at least 90% boiling by 350° C., at least 10% by 150° C., and 50% boiling between 220° C. and 280° C.

[0029] FIG. 20 is a graph of the boiling point curve of r-pyoil distilled in lab with 90% boiling between 250-300° C.

[0030] FIG. 21 is a graph of the boiling point curve of r-pyoil distilled in lab with 50% boiling between 60-80° C.

[0031] FIG. 22 is a graph of the boiling point curve of r-pyoil distilled in lab with 34.7% aromatic content.

[0032] FIG. 23 is a graph of the distillation curve from the r-pyoil use in the plant test

[0033] FIG. 24 is a graph of the carbon distribution of the pyoil base on wt percent in the plant test.

[0034] FIG. 25 is a graph of the carbon distribution of the pyoil base on wt percent in the plant test.

DESCRIPTION

[0035] When a numerical sequence is indicated, it is to be understood that each number is modified the same as the first number or last number in the numerical sequence or in the sentence, e.g., each number is “at least,” or “up to” or “not more than” as the case may be; and each number is in an “or” relationship. For example, “at least 10, 20, 30, 40, 50, 75 wt. % . . .” means the same as “at least 10 wt. %, or at least 20 wt. %, or at least 30 wt. %, or at least 40 wt. %, or at least 50 wt. %, or at least 75 wt. %,” etc.; and “not more than 90 wt. %, 85, 70, 60 . . .” means the same as “not more than 90 wt. %, or not more than 85 wt. %, or not more than 70 wt. % . . .” etc.; and “at least 1%, 2%, 3%, 4%, 5%, 6%, 7%, 8%, 9% or 10% by weight . . .” means the same as “at least 1 wt. %, or at least 2 wt. %, or at least 3 wt. % . . .” etc.; and “at least 5, 10, 15, 20 and/or not more than 99, 95, 90 weight percent” means the same as “at least 5 wt. %, or at least 10 wt. %, or at least 15 wt. % or at least 20 wt. % and/or not more than 99 wt. %, or not more than 95 wt. %, or not more than 90 weight percent . . .” etc.; or “at least 500, 600, 750° C. . .” means the same as “at least 500° C., or at least 600° C., or at least 750° C. . .” etc.

[0036] All concentrations or amounts are by weight unless otherwise stated. An “olefin-containing effluent” is the furnace effluent obtained by cracking a cracker feed containing r-pyoil. A “non-recycle olefin-containing effluent” is the furnace effluent obtained by cracking a cracker feed that does not contain r-pyoil. Units on hydrocarbon mass flow rate, MF1, and MF2 are in kilo pounds/hr (klb/hr), unless otherwise stated as a molar flow rate.

[0037] FIG. 1 is a schematic depiction illustrating an embodiment or in combination with any embodiment mentioned herein of a process for employing a recycle content pyrolysis oil composition (r-pyoil) to make one or more recycle content compositions (e.g., ethylene, propylene, butadiene, hydrogen, and/or pyrolysis gasoline): the r-composition.

[0038] As shown in FIG. 1, recycled waste can be subjected to pyrolysis in pyrolysis unit 10 to produce a pyrolysis product/effluent comprising a recycle content pyrolysis oil composition (r-pyoil). The r-pyoil can be fed to a cracker 20, along with a non-recycle cracker feed (e.g., propene, ethane, and/or natural gasoline). A recycle content cracked effluent (r-cracked effluent) can be produced from the cracker and then subjected to separation in a separation train 30. In an embodiment or in combination with any embodiment mentioned herein or in combination with any of the mentioned embodiments, the r-composition can be separated and recovered from the r-cracked effluent. The r-propylene stream can contain predominantly propylene, while the r-ethylene stream can contain predominately ethylene.

[0039] As used herein, a furnace includes the convection zone and the radiant zone. A convection zone includes the tubes and/or coils inside the convection box that can also continue outside the convection box downstream of the coil inlet at the entrance to the convection box. For example, as shown in FIG. 5, the convection zone 310 includes the coils and tubes inside the convection box 312 and can optionally extend or be interconnected with piping 314 outside the convection box 312 and returning inside the convection box 312. The radiant zone 320 includes radiant coils/tubes 324 and burners 326. The convection zone 310 and radiant zone 320 can be contained in a single unitary box, or in separate discrete boxes. The convection box 312 does not necessarily have to be a separate discrete box. As shown in FIG. 5, the convection box 312 is integrated with the firebox 322.

[0040] Unless otherwise specified, all component amounts provided herein (e.g., for feeds, feedstocks, streams, compositions, and products) are expressed on a dry basis.

[0041] As used herein, a “r-pyoil” or “r-pyrolysis oil” are interchangeable and mean a composition of matter that is liquid when measured at 25° C. and 1 atm, and at least a portion of which is obtained from the pyrolysis of recycled waste (e.g., waste plastic or waste stream).

[0042] As used herein, “r-ethylene” means a composition comprising: (a) ethylene obtained from cracking of a cracker feed containing r-pyoil, or (b) ethylene having a recycle content value or allotment applied to at least a portion of the ethylene and “r-propylene” means a composition comprising: (a) propylene obtained from cracking of a cracker feed containing r-pyoil, or (b) propylene having a recycle content value or allotment applied to at least a portion of the propylene.

[0043] Reference to a “r-ethylene molecule” means an ethylene molecule derived directly from the cracking of a cracker feed containing r-pyoil. Reference to a “r-propylene molecule” means a propylene molecule derived directly from a cracker feed containing cracking of r-pyoil.

[0044] As used herein, the term “predominantly” means more than 50 percent by weight, unless expressed in mole percent, in which case it means more than 50 mole %. For example, a predominantly propane stream, composition, feedstock, or product is a stream, composition, feedstock, or product that contains more than 50 weight percent propane,

or if expressed as mole %, means a product that contains more than 50 mole % propane.

[0045] As used herein, the term “recycle content” is used i) as a noun to refer to a physical component (e.g., compound, molecule, or atom) originating from r-pyoil or ii) as an adjective modifying a particular composition (e.g., a feedstock or product) at least a portion of which is directly or indirectly derived from r-pyoil.

[0046] As used herein, a composition that is “directly derived” from cracking r-pyoil has at least one physical component that is traceable to an r-composition at least a portion of which is obtained by or with the cracking of r-pyoil, while a composition that is “indirectly derived” from cracking r-pyoil has associated with it a recycle content allotment and may or may not contain a physical component that is traceable to an r-composition at least a portion of which is obtained by or with the cracking of r-pyoil.

[0047] A “recycle content value” is a unit of measure representative of a quantity of material having its origin in r-pyoil. The recycle content value can have its origin in any type of r-pyoil and in any type of cracker furnace used to crack the r-pyoil.

[0048] The particular recycle content value can be determined by a mass balance approach or a mass ratio or percentage or any other unit of measure and can be determined according to any system for tracking, allocating, and/or crediting recycle content among various compositions. A recycle content value can be deducted from a recycle content inventory and applied to a product or composition to attribute recycle content to the product or composition. A recycle content value does not have to originate from making or cracking r-pyoil unless so stated. In one embodiment or in combination with any mentioned embodiments, at least a portion of the r-pyoil from which an allotment is obtained is also cracked in a cracking furnace as described throughout the one or more embodiments herein.

[0049] In one embodiment or in combination with any mentioned embodiments, at least a portion of the recycle content allotment or allotment or recycle content value deposited into a recycle content inventory is obtained from r-pyoil. Desirably, at least 60%, or at least 70%, or at least 80%, or at least 90% or at least 95%, or up to 100% of the:

[0050] a. allotments or

[0051] b. deposits into a recycle content inventory, or

[0052] c. recycle content value in a recycle content inventory, or

[0053] d. recycle content value applied to compositions to make a recycle content product, intermediate, or article (Recycle PIA) are obtained from r-pyoil.

[0054] A Recycle PIA is a product, intermediate which can include compounds or compositions containing compounds or polymers, and/or an article having an associated recycle content value. A PIA does not have a recycle content value associated with it. As used herein, the term “recycle content allotment” or “allotment” means a recycle content value that is transferred from an originating composition, at least a portion of which recycle content value is obtained by or with the cracking of r-pyoil, to a receiving composition (the composition receiving the allotment) that may or may not have physical component that is traceable to a composition at least a portion of which is obtained by or with the cracking of r-pyoil, where the recycle content value (whether by mass or percentage or any other unit of measure) is determined according to a standard system for tracking, allocating,

and/or crediting recycle content among various compositions. A “composition” that receives an allotment or recycle content value can include a composition of matter, compound, product, polymer, or article.

[0055] A “recycle content allotment” or “allotment” means a recycle content value that is:

[0056] a. transferred from r-pyoil, or recycle waste used to make r-pyoil (for convenience referred to herein collectively as “r-pyoil”) to a receiving composition or a Recycle PIA that may or may not have a physical component that is traceable to the r-pyoil; or

[0057] b. deposited into a recycle content inventory, at least a portion of which originates from r-pyoil.

[0058] An allotment can be an allocation or a credit.

[0059] In an embodiment or in combination with any embodiment mentioned herein or in combination with any of the mentioned embodiments, the composition receiving the recycle content allotment can be a non-recycle composition, to thereby convert the non-recycle composition to an r-composition. As used herein, “non-recycle” means a composition none of which was directly or indirectly derived from the cracking of r-pyoil. As used herein, a “non-recycle feed” in the context of a feed to the cracker or furnace means a feed that is not obtained from a waste stream or r-pyoil. Once a non-recycle feed or PIA obtains a recycle content allotment (e.g., either through a credit or allocation), it becomes a recycle content feed, composition, or Recycle PIA.

[0060] As used herein, the term “recycle content allocation” is a type of recycle content allotment, where the entity or person supplying the composition sells or transfers the composition to the receiving person or entity, and the person entity making the composition has an allotment at least a portion of which can be associated with the composition sold or transferred by the supplying person or entity to the receiving person or entity. The supplying entity or person can be controlled by the same person or entity or a variety of affiliates that are ultimately controlled or owned at least in part by a parent entity (“Family of Entities”), or they can be from a different Family of Entities. Generally, a recycle content allocation travels with a composition and with the downstream derivatives of the composition. An allocation may be deposited into a recycle content inventory and withdrawn from the recycle content inventory as an allocation and applied to a composition to make an r-composition or a Recycle PIA.

[0061] The term “recycle content credit” means a recycle content allotment, where the allotment is not restricted to an association with compositions made from cracking r-pyoil or their downstream derivatives, but rather have the flexibility of being obtained from r-pyoil and (i) applied to compositions or PIA made from processes other than cracking feedstocks in a furnace, or (ii) applied to downstream derivatives of compositions, through one or more intermediate feedstocks, where such compositions are made from processes other than cracking feedstocks in a furnace, or (iii) available for sale or transfer to persons or entities other than the owner of the allotment, or (iv) available for sale or transfer by other than the supplier of the composition that is transferred to the receiving entity or person. For example, an allotment can be a credit when the allotment is taken from r-pyoil and applied by the owner of the allotment to a BTX composition, or cuts thereof, made by said owner or within its Family of Entities, obtained by refining and fractionation

of petroleum rather than obtained by cracker effluent products; or it can be a credit if the owner of the allotment sells the allotment to a third party to allow the third party to either re-sell the product or apply the credit to one or more of a third party's compositions.

[0062] A credit can be available for sale or transfer or use, or is sold or transferred or used, either:

[0063] a. without the sale of a composition, or

[0064] b. with the sale or transfer of a composition but the allotment is not associated the sale or transfer of the composition, or

[0065] c. is deposited into or withdrawn from a recycle content inventory that does not track the molecules of a recycle content feedstock to the molecules of the resulting compositions which were made with the recycle content feedstocks, or which does have such tracking capability but which did not track the particular allotment as applied to a composition.

[0066] In one embodiment or in combination with any of the mentioned embodiments, an allotment may be deposited into a recycle content inventory, and a credit or allocation may be withdrawn from the inventory and applied to a composition. This would be the case where an allotment is created from a r-pyoil and deposited into a recycle content inventory, and deducting a recycle content value from the recycle content inventory and applying it to a composition to make an r-composition that either has no portion originating from the products of a cracker furnace, or does have a portion originating from the products of a cracker furnace but such products making up the portion of the composition were not obtained by cracking r-pyoil. In this system, one need not trace the source of a reactant back to the cracking r-pyoil olefin-containing effluent olefin-containing effluent olefin-containing effluent or back to any atoms contained in r-pyoil olefin-containing effluent olefin-containing effluent olefin-containing effluent, but rather can use any reactant made by any process and have associated with such reactant a recycle content allotment.

[0067] In one embodiment or in combination with any mentioned embodiments, a composition receiving an allotment is used as a feedstock to make downstream derivatives of the composition, and such composition is a product of cracking a cracker feedstock in a cracker furnace. In one embodiment or in combination with any mentioned embodiments, there is provided a process in which:

[0068] a. a r-pyoil is obtained,

[0069] b. a recycle content value (or allotment) is obtained from the r-pyoil and

[0070] i. deposited into a recycle content inventory, and an allotment (or credit) is withdrawn from the recycle content inventory and applied to any composition to obtain a r-composition, or

[0071] ii. applied directly to any composition, without depositing into a recycle content inventory, to obtain an r-composition; and

[0072] c. at least a portion of the r-pyoil is cracked in a cracker furnace, optionally according to any of the designs or processes described herein; and

[0073] d. optionally at least a portion of the composition in step b. originates from a cracking a cracker feedstock in a cracker furnace, optionally the composition having been obtained by any of the feedstocks, including r-pyoil, and methods described herein.

[0074] The steps b. and c. do not have to occur simultaneously. In one embodiment or in combination with any mentioned embodiments, they occur within a year of each other, or within six (6) months of each other, or within three (3) months of each other, or within one (1) month of each other, or within two (2) weeks of each other, or within one (1) week of each other, or within three (3) days of each other. The process allows for a time lapse between the time an entity or person receiving the r-pyoil and creating the allotment (which can occur upon receipt or ownership of the r-pyoil or deposit into inventory) and the actual processing of the r-pyoil in a cracker furnace.

[0075] As used herein, "recycle content inventory" and "inventory" mean a group or collection of allotments (allocations or credits) from which deposits and deductions of allotments in any units can be tracked. The inventory can be in any form (electronic or paper), using any or multiple software programs, or using a variety of modules or applications that together as a whole tracks the deposits and deductions. Desirably, the total amount of recycle content withdrawn (or applied to compositions) does not exceed the total amount of recycle content allotments on deposit in the recycle content inventory (from any source, not only from cracking of r-pyoil). However, if a deficit of recycle content value is realized, the recycle content inventory is rebalanced to achieve a zero or positive recycle content value available. The timing for rebalancing can be either determined and managed in accordance with the rules of a particular system of accreditation adopted by the olefin-containing effluent manufacturer or by one among its Family of Entities, or alternatively, is rebalanced within one (1) year, or within six (6) months, or within three (3) months, or within one (1) month of realizing the deficit. The timing for depositing an allotment into the recycle content inventory, applying an allotment (or credit) to a composition to make a r-composition, and cracking r-pyoil, need not be simultaneous or in any particular order. In one embodiment or in combination with any mentioned embodiments, the step of cracking a particular volume of r-pyoil occurs after the recycle content value or allotment from that volume of r-pyoil is deposited into a recycle content inventory. Further, the allotments or recycle content values withdrawn from the recycle content inventory need not be traceable to r-pyoil or cracking r-pyoil, but rather can be obtained from any waste recycle stream, and from any method of processing the recycle waste stream. Desirably, at least a portion of the recycle content value in the recycle content inventory is obtained from r-pyoil, and optionally at least a portion of r-pyoil, are processed in the one or more cracking processes as described herein, optionally within a year of each other and optionally at least a portion of the volume of r-pyoil from which a recycle content value is deposited into the recycle content inventory is also processed by any or more of the cracking processes described herein.

[0076] The determination of whether the r-composition is derived directly or indirectly from cracking r-pyoil is not on the basis of whether intermediate steps or entities do or do not exist in the supply chain, but rather whether at least a portion of the r-composition that is fed to the reactor for making an end product can be traced to r-composition made from the cracking of r-pyoil.

[0077] As noted above, the end product is considered to be directly derived from cracking r-pyoil if at least a portion of the atoms or molecules in reactant feedstock used to make

the product can be traced back, optionally through one or more intermediate steps or entities, to at least a portion of the atoms or molecules that make up an r-composition produced during the cracking of r-pyoil fed to the cracking furnace. Any number of intermediaries and intermediate derivatives can be made before the r-composition is made. The r-composition manufacturer can, typically after refining and/or purification and compression to produce the desired grade of the particular r-composition, sell such r-composition to an intermediary entity who then sells the r-composition, or one or more derivatives thereof, to another intermediary for making an intermediate product or directly to the product manufacturer. Any number of intermediaries and intermediate derivatives can be made before the final product is made. The actual r-composition volume, whether condensed as a liquid, supercritical, or stored as a gas, can remain at the facility where it is made, or can be shipped to a different location, or held at an off-site storage facility before utilized by the intermediary or product manufacturer. For purposes of tracing, once r-composition made by cracking r-pyoil is mixed with another volume of the composition (e.g. r-ethylene mixed with non-recycle ethylene), for example in a storage tank, salt dome, or cavern, then the entire tank, dome, or cavern at that point becomes a r-composition source, and for purposes of tracing, withdrawal from such storage facility is withdrawing from an r-composition source until such time as when the entire volume or inventory of the storage facility is turned over or withdrawn and/or replaced with non-recycle compositions after the r-composition feed to the tank stops.

[0078] An r-composition is considered to be indirectly derived from the cracking of r-pyoil if it has associated with it a recycle content allotment and may or may not contain a physical component that is traceable to an r-composition at least a portion of which is obtained by or with the cracking of r-pyoil. For example, the (i) manufacturer of the product can operate within a legal framework, or an association framework, or an industry recognized framework for making a claim to a recycle content through, for example, a system of credits transferred to the product manufacturer regardless of where or from whom the r-composition, or derivatives thereof, or reactant feedstocks to make the product, is purchased or transferred, or (ii) a supplier of the r-composition or a derivative thereof ("supplier") operates within an allotment framework that allows for associating a recycle content value to a portion or all of an olefin-containing effluent or a compound within an olefin-containing effluent or derivative thereof and to transfer the allotment to the manufacturer of the product or any intermediary who obtains a supply of one or more compounds in an olefin-containing effluent, or its derivatives, from the supplier. The transfer can occur by virtue of the supplier transferring an r-compound to the manufacturer of the product or intermediary, or by transferring the allotment (e.g., credit) without associating such allotment to the compound transferred. In this system, one need not trace the source of an olefin volume from cracking r-pyoil, but rather can use any olefin volume made by any process and have associated with such olefin volume a recycle content allotment.

[0079] Examples of where the r-composition is r-olefin (e.g., r-ethylene or r-propylene) and the product is an olefin-derived petrochemical (e.g., reaction product of the r-olefin or blend with the r-olefin) that is directly or indirectly derived from the r-olefin obtained from r-pyoil include:

[0080] a cracker facility in which the r-olefin made at the facility can be in fluid communication, continuously or intermittently, with an olefin-derived petrochemical formation facility (which can be to a storage vessel at the olefin-derived petrochemical facility or directly to the olefin-derived petrochemical formation reactor) through interconnected pipes, optionally through one or more storage vessels and valves or interlocks, and the r-olefin feedstock is drawn through the interconnected piping:

[0081] from the cracker facility while r-olefin is being made or thereafter within the time for the r-olefin to transport through the piping to the olefin-derived petrochemical formation facility or

[0082] from the one or more storage tanks at any time provided that at least one of the storage tanks was fed with r-olefin, and continue for so long as the entire volume of the one or more storage tanks is replaced with a feed that does not contain r-olefin; or

[0083] transporting olefin from a storage vessel, dome, or facility, or in an isotainer via truck or rail or ship or a means other than piping, that contains or has been fed with r-olefin until such time as the entire volume of the vessel, dome or facility has been replaced with an olefin feed that does not contain r-olefin; or

[0084] the manufacturer of the olefin-derived petrochemical certifies, represents to its customers or the public, or advertises that its olefin-derived petrochemical contains recycle content or is obtained from feedstock containing or obtained from recycle content, where such recycle content claim is based in whole or in part on obtaining r-olefin; or

the manufacturer of the olefin-derived petrochemical has acquired:

[0085] an olefin volume made from r-pyoil under a certification, representation, or as advertised, or

[0086] has transferred credits with the supply of olefin to the manufacturer of the olefin-derived petrochemical sufficient to allow the manufacturer of the olefin-derived petrochemical to satisfy the certification requirements or to make its representations or advertisements, or an olefin that has an associated recycle content value where such recycle content value was obtained, through one or more intermediary independent entities, from r-pyoil.

[0087] In an embodiment or in combination with any embodiment mentioned herein or in combination with any of the mentioned embodiments, the recycle content can be directly or indirectly derived from cracking r-pyoil, where at least a portion of the r-pyoil is obtained from the pyrolysis of recycled waste (e.g., waste plastic or waste stream).

[0088] In one embodiment or in combination with any mentioned embodiments, there is provided a variety of methods for apportioning the recycle content among the various olefin-containing effluent volumes, or compounds thereof, made by any one entity or a combination of entities among the Family of Entities olefin-containing effluent. For example, the cracker furnace owner or operator olefin-containing effluent, or any among its Family of Entities, or a Site, can:

[0089] a. adopt a symmetric distribution of recycle content values among at least two compounds within the olefin-containing effluent or among RIA it makes based on the same fractional percentage of recycle

content in one or more feedstocks or based on the amount of allotment received. For example, if 5 wt. % of the entire cracker feedstock to a furnace is r-pyoil, then one or more of the compounds in the olefin-containing effluent may contain 5 wt. % recycle content value, or one or more compounds can contain 5 wt. % recycle content value less any yield losses, or one or more of the PIA can contain a 5% recycle content value. In this case, the amount of recycle content in the compounds is proportional to all the other products receiving the recycle content value; or

[0090] b. adopt an asymmetric distribution of recycle content values among the compounds in the olefin-containing effluent or among its PIA. In this case, the recycle content value associated with a compound or RIA on a can exceed the recycle content value associated with other compounds or RIA. For example, one volume or batch of olefin-containing effluent can receive a greater amount of recycle content value than other batches or volume of olefin-containing effluent, or one or a combination of compounds among the olefin-containing effluent to receive a disproportionately higher amount of recycle content value relative to the other compounds in the olefin-containing effluent or other PIA, some of which may receive no recycle content value. One volume of olefin-containing effluent or PIA can contain 20% recycle content by mass, and another volume or RIA can contain zero 0% recycle content, even though both volumes may be compositionally the same and continuously produced, provided that the amount of recycle content value withdrawn from a recycle content inventory and applied to the olefin-containing effluent does not exceed the amount of recycle content value deposited into the recycle content inventory, or if a deficit is realized, the overdraft is rebalanced to zero or a positive credit available status as described above, or if no recycle content inventory exists, then provided that total amount of recycle content value associated with any one more compounds in the olefin-containing effluent does not exceed the allotment obtained from the r-pyoil or it is exceeded, is then rebalanced. In the asymmetric distribution of recycle content, a manufacturer can tailor the recycle content to volumes of olefin-containing effluent or to the compounds of interest in the olefin-containing effluent or PIA that are sold as needed among customers, thereby providing flexibility among customers some of whom may need more recycle content than others in an r-compound or Recycle PIA.

[0091] In an embodiment or in combination with any embodiment mentioned herein, both the symmetric distribution and the asymmetric distribution of recycle content can be proportional on a Site wide basis, or on a multi-Site basis. In one embodiment or in combination with any of the mentioned embodiments, the recycle content obtained from r-pyoil can be within a Site, and recycle content values from the r-pyoil can be applied to one or more olefin-containing effluent volumes or one or more compounds in a volume of olefin-containing effluent or to one or more PIA made at the same Site from compounds in an olefin-containing effluent. The recycle content values can be applied symmetrically or asymmetrically to one or more different olefin-containing effluent volumes or one or more compounds within an olefin-containing effluent or PIA made at the Site.

[0092] In one embodiment or in combination with any of the mentioned embodiments, the recycle content input or creation (recycle content feedstock or allotments) can be to or at a first Site, and recycle content values from said inputs are transferred to a second Site and applied to one or more compositions made at a second Site. The recycle content values can be applied symmetrically or asymmetrically to the compositions at the second Site. A recycle content value that is directly or indirectly “derived from cracking r-pyoil,” or a recycle content value that is “obtained from cracking r-pyoil” or originating in cracking r-pyoil does not imply the timing of when the recycle content value or allotment is taken, captured, deposited into a recycle content inventory, or transferred. The timing of depositing the allotment or recycle content value into a recycle content inventory, or realizing, recognizing, capturing, or transferring it, is flexible and can occur as early as receipt of r-pyoil onto the site within a Family of Entities, possessing it, or bringing the r-pyoil into inventory by the entity or person, or within the Family of Entities, owning or operating the cracker facility. Thus, an allotment or recycle content value on a volume of r-pyoil can be obtained, captured, deposited into a recycle content inventory, or transferred to a product without having yet fed that volume to cracker furnace and cracked. The allotment can also be obtained during feeding r-pyoil to a cracker, during cracking, or when an r-composition is made. An allotment taken when r-pyoil is owned, possessed, or received and deposited into a recycle content inventory is an allotment that is associated with, obtained from, or originates from cracking r-pyoil even though, at the time of taking or depositing the allotment, the r-pyoil has not yet been cracked, provided that the r-pyoil is at some future point in time cracked.

[0093] In an embodiment, the r-composition, or downstream reaction products thereof, or Recycle PIA, has associated with it, or contains, or is labelled, advertised, or certified as containing recycle content in an amount of at least 0.01 wt. %, or at least 0.05 wt. %, or at least 0.1 wt. %, or at least 0.5 wt. %, or at least 0.75 wt. %, or at least 1 wt. %, or at least 1.25 wt. %, or at least 1.5 wt. %, or at least 1.75 wt. %, or at least 2 wt. %, or at least 2.25 wt. %, or at least 2.5 wt. %, or at least 2.75 wt. %, or at least 3 wt. %, or at least 3.5 wt. %, or at least 4 wt. %, or at least 4.5 wt. %, or at least 5 wt. %, or at least 6 wt. %, or at least 7 wt. %, or at least 10 wt. %, or at least 15 wt. %, or at least 20 wt. %, or at least 25 wt. %, or at least 30 wt. %, or at least 35 wt. %, or at least 40 wt. %, or at least 45 wt. %, or at least 50 wt. %, or at least 55 wt. %, or at least 60 wt. %, or at least 65 wt. % and/or the amount can be up to 100 wt. %, or up to 95 wt. %, or up to 90 wt. %, or up to 80 wt. %, or up to 70 wt. %, or up to 60 wt. %, or up to 50 wt. %, or up to 40 wt. %, or up to 30 wt. %, or up to 25 wt. %, or up to 22 wt. %, or up to 20 wt. %, or up to 18 wt. %, or up to 16 wt. %, or up to 15 wt. %, or up to 14 wt. %, or up to 13 wt. %, or up to 11 wt. %, or up to 10 wt. %, or up to 8 wt. %, or up to 6 wt. %, or up to 5 wt. %, or up to 4 wt. %, or up to 3 wt. %, or up to 2 wt. %, or up to 1 wt. %, or up to 0.9 wt. %, or up to 0.8 wt. %, or up to 0.7 wt. %. The recycle content value associated with the r-composition, r-compounds or downstream reaction products thereof can be associated by applying an allotment (credit or allocation) to any composition, compound, PIA made or sold. The allotment can be contained in an inventory of allotments created, maintained or operated by or for the Recycle PIA or r-composition

manufacturer. The allotment can be obtained from any source along any manufacturing chain of products provided that its origin is in cracking a feedstock containing r-pyoil.

[0094] In one embodiment or in combination with any mentioned embodiments, the Recycle PIA manufacturer can make a Recycle PIA, or process a reactant to make a Recycle PIA by obtaining, from any source, a reactant (e.g. any of the compounds of an olefin-containing cracker effluent) from a supplier (e.g. a cracker manufacturer or one among its Family of Entities), whether or not such reactant has any recycle content, and either:

[0095] i. from the same supplier of the reactant, also obtain a recycle content allotment applied to the reactant, or

[0096] ii. from any person or entity, obtaining a recycle content allotment without a supply of a reactant from said person or entity transferring said recycle content allotment.

[0097] The allotment in (i) is obtained from a reactant supplier who also supplies a reactant to the Recycle PIA manufacturer or within its Family of Entities. The circumstance described in (i) allows a Recycle PIA manufacturer to obtain a supply of a reactant that is a non-recycle content reactant yet obtain a recycle content allotment from the reactant supplier. In one embodiment or in combination with any mentioned embodiments, the reactant supplier transfers a recycle content allotment to the Recycle PIA manufacturer and a supply of a reactant (e.g., propylene, ethylene, butylene, etc.) to the Recycle PIA manufacturer, where the recycle content allotment is not associated with the reactant supplied, or even not associated with any reactant made by the reactant supplier. The recycle content allotment does not have to be tied to the reactant supplied or tied to an amount of recycle content in a reactant used to make Recycle PIA, olefin-containing effluent olefin-containing effluent This allows flexibility among the reactant supplier and Recycle PIA manufacturer to apportion a recycle content among the variety of products they each make. In each of these cases, however, the recycle content allotment is associated with cracking r-pyoil.

[0098] In one embodiment or in combination with any mentioned embodiments, the reactant supplier transfers a recycle content allotment to the Recycle PIA manufacturer and a supply of reactant to the Recycle PIA manufacturer, where the recycle content allotment is associated with the reactant. The transfer of the allotment can occur merely by virtue of supplying the reactant having an associated recycle content. Optionally, the reactant being supplied is an r-compound separated from an olefin-containing effluent made by cracking r-pyoil and at least a portion of the recycle content allotment is associated with the r-compound (or r-reactant). The recycle content allotment transferred to the Recycle PIA manufacturer can be up front with the reactant supplied, optionally in installments, or with each reactant installment, or apportioned as desired among the parties.

[0099] The allotment in (ii) is obtained by the Recycle PIA manufacturer (or its Family of Entities) from any person or entity without obtaining a supply of reactant from the person or entity. The person or entity can be a reactant manufacturer that does not supply reactant to the Recycle PIA manufacturer or its Family of Entities, or the person or entity can be a manufacturer that does not make the reactant. In either case, the circumstances of (ii) allows a Recycle PIA manufacturer to obtain a recycle content allotment without having

to purchase any reactant from the entity or person supplying the recycle content allotment. For example, the person or entity may transfer a recycle content allotment through a buy/sell model or contract to the Recycle PIA manufacturer or its Family of Entities without requiring purchase or sale of an allotment (e.g., as a product swap of products that are not a reactant), or the person or entity may outright sell the allotment to the Recycle PIA manufacturer or one among its Family of Entities. Alternatively, the person or entity may transfer a product, other than a reactant, along with its associated recycle content allotment to the Recycle PIA manufacturer. This can be attractive to a Recycle PIA manufacturer that has a diversified business making a variety of PIA other than those requiring made from the supplied reactant.

[0100] The allotment can be deposited into a recycle content inventory (e.g., an inventory of allotments). In one embodiment or in combination with any mentioned embodiments, the allotment is created by the manufacturer of the olefin-containing effluent olefin-containing effluent olefin-containing effluent. The manufacturer can also make a PIA, whether or not a recycle content is applied to the PIA and whether or not recycle content, if applied to the PIA, is drawn from the recycle content inventory. For example, the olefin-containing effluent olefin-containing effluent manufacturer of the olefin-containing effluent may:

[0101] a. deposit the allotment into an inventory and merely store it; or

[0102] b. olefin-containing effluent olefin-containing effluent deposit the allotment into an inventory and apply allotments from the inventory to a compound or compounds within the olefin-containing effluent or to any PIA made by the manufacturer, or

[0103] c. sell or transfer the allotment to a third party from the recycle content inventory into which at least one allotment, obtained as noted above, was deposited.

[0104] If desired, any recycle content allotment can be deducted in any amount and applied to a PIA to make a Recycle PIA or applied to a non-recycle olefin-containing effluent to make an olefin-containing effluent. For example, allotments can be generated having a variety of sources for creating the allotments. Some recycle content allotments (credits) can have their origin in methanolysis of recycle waste, or from gasification of other types of recycle waste, or from mechanical recycling of waste plastic or metal recycling, or from any other chemical or mechanical recycling technology. The recycle content inventory may or may not track the origin or basis of obtaining a recycle content value, or the inventory may not allow one to associate the origin or basis of an allotment to the allotment applied to r-composition. It is sufficient that an allotment is deducted from a the recycle content inventory and applied to a PIA or a non-recycle olefin-containing effluent regardless of the source or origin of the allotment, provided that a recycle content allotment derived from r-pyoil is present in the recycle content inventory at the time of withdrawal, or a recycle content allotment is obtained by the Recycle PIA manufacturer as specified in step (i) or step (ii), whether or not that recycle content allotment is actually deposited into the recycle content inventory.

[0105] In one embodiment or in combination with any mentioned embodiments, the recycle content allotment obtained in step (i) or (ii) is deposited into an inventory of allotments. In one embodiment or in combination with any

mentioned embodiments, the recycle content allotment deducted from the recycle content inventory and applied to PIA or a non-recycle olefin-containing effluent (or any compounds therein) originates from r-pyoil.

[0106] As used throughout, the recycle content inventory can be owned by the owner of a cracker furnace that processes r-pyoil or one among its Family of Entities, olefin-containing effluent or by the Recycle PIA manufacturer, or operated by either of them, or owned or operated by neither but at least in part for the benefit of either of them, or licensed by or to either of them. Also, cracker olefin-containing effluent manufacturer or the Recycle PIA manufacturer may also include either of their Family of Entities. For example, while either of them may not own or operate the inventory, one among its Family of Entities may own such a platform, or license it from an independent vendor, or operate it for either of them. Alternatively, an independent entity may own and/or operate the inventory and for a service fee operate and/or manage at least a portion of the inventory for either of them.

[0107] In one embodiment or in combination with any mentioned embodiments, the Recycle PIA manufacturer obtains a supply of reactant from a supplier, and also obtains an allotment from the supplier, where such allotment is derived from r-pyoil, and optionally the allotment is associated with the reactant supplied by the supplier. In one embodiment or in combination with any mentioned embodiments, at least a portion of the allotment obtained by the Recycle PIA manufacturer is either:

[0108] a. applied to PIA made by the supply of the reactant;

[0109] b. applied to PIA made by the same type of reactant but not made by the volume of reactant supplied, such as would be the case where PIA made with the same type of reactant is already made and stored in inventory or future made PIA; or

[0110] c. deposited into an inventory from which is deducted an allotment that is applied to PIA made by other than the type of reactant supplied, or

[0111] d. deposited into an inventory and stored.

[0112] It is not necessary in all embodiments that r-reactant is used to make Recycle PIA or that the Recycle PIA was obtained from a recycle content allotment associated with a reactant. Further, it is not necessary that an allotment be applied to the feedstock for making the Recycle PIA to which recycle content is applied. Rather, as noted above, the allotment, even if associated with a reactant when the reactant is obtained, can be deposited into an electronic inventory. In one embodiment or in combination with any mentioned embodiments, however, reactant associated with the allotment is used to make the Recycle PIA. In one embodiment or in combination with any mentioned embodiments, the Recycle PIA is obtained from a recycle content allotment associated with an r-reactant, or r-pyoil, or with cracking r-pyoil. In one embodiment or in combination with any mentioned embodiments,

[0113] In one embodiment or in combination with any mentioned embodiments, the olefin-containing effluent olefin-containing effluent olefin-containing effluent manufacturer generates an allotment from r-pyoil, and either:

[0114] a. Applies the allotment to any PIA made directly or indirectly (e.g., through a reaction scheme of several intermediates) from cracking r-pyoil olefin-containing effluent olefin-containing effluent; or

[0115] b. Applies the allotment to any PIA not made directly or indirectly from cracking r-pyoil olefin-containing effluent olefin-containing effluent, such as would be the case where the PIA is already made and stored in inventory or future made PIA; or

[0116] c. deposited into an inventory from which is deducted any allotment that is applied to PIA; and the deposited allotment either is or is not associated with the particular allotment applied to the PIA; or

[0117] d. is deposited into an inventory and stored for use at a later time.

[0118] There is now also be provided a package or a combination of a Recycle PIA and a recycle content identifier associated with Recycle PIA, where the identifier is or contains a representation that the Recycle PIA contains or is sourced from or associated with a recycle content. The package can be any suitable package for containing a polymer and/or article, such as a plastic or metal drum, railroad car, isotainer, totes, polytote, bale, IBC totes, bottles, compressed bales, jerricans, and polybags, spools, roving, winding, or cardboard packaging. The identifier can be a certificate document, a product specification stating the recycle content, a label, a logo or certification mark from a certification agency representing that the article or package contains contents or the Recycle PIA contains, or is made from sources or associated with recycle content, or it can be electronic statements by the Recycle PIA manufacturer that accompany a purchase order or the product, or posted on a website as a statement, representation, or a logo representing that the Recycle PIA contains or is made from sources that are associated with or contain recycle content, or it can be an advertisement transmitted electronically, by or in a website, by email, or by television, or through a tradeshow, in each case that is associated with Recycle PIA. The identifier need not state or represent that the recycle content is derived from r-pyoil. Rather, the identifier can merely convey or communicate that the Recycle PIA has or is sourced from a recycle content, regardless of the source. However, the Recycle PIA has a recycle content allotment that, at least in part, associated with r-pyoil.

[0119] In one embodiment or in combination with any mentioned embodiments, one may communicate recycle content information about the Recycle PIA to a third party where such recycle content information is based on or derived from at least a portion of the allocation or credit. The third party may be a customer of the olefin-containing effluent olefin-containing effluent manufacturer or of the Recycle PIA manufacturer or may be any other person or entity or governmental organization other than the entity owning the either of them. The communication may electronic, by document, by advertisement, or any other means of communication.

[0120] In one embodiment or in combination with any mentioned embodiments, there is provided a system or package comprising:

[0121] a. Recycle PIA, and

[0122] b. an identifier such as a credit, label or certification associated with said PIA, where the identifier is a representation that the PIA has, or is sourced from, a recycle content (which does not have to identify the source of the recycle content or allotment)

provided that the Recycle PIA made thereby has an allotment, or is made from a reactant, at least in part associated with r-pyoil.

[0123] The system can be a physical combination, such as package having at least Recycle PIA as its contents and the package has a label, such as a logo, that the contents such as the Recycle PIA has or is sourced from a recycle content. Alternatively, the label or certification can be issued to a third party or customer as part of a standard operating procedure of an entity whenever it transfers or sells Recycle PIA having or sourced from recycle content. The identifier does not have to be physically on the Recycle PIA or on a package and does not have to be on any physical document that accompanies or is associated with the Recycle PIA or package. For example, the identifier can be an electronic document, certification, or accreditation logo associated with the sale of the Recycle PIA to a customer. The identifier itself need only convey or communicate that the Recycle PIA has or is sourced from a recycle content, regardless of the source. In one embodiment or in combination with any mentioned embodiments, articles made from the Recycle PIA may have the identifier, such as a stamp or logo embedded or adhered to the article or package. In one embodiment or in combination with any mentioned embodiments, the identifier is an electronic recycle content credit from any source. In one embodiment or in combination with any mentioned embodiments, the identifier is an electronic recycle content credit having its origin in r-pyoil.

[0124] The Recycle PIA is made from a reactant, whether or not the reactant is a recycle content reactant. Once a PIA is made, it can be designated as having recycle content based on and derived from at least a portion of the allotment. The allotment can be withdrawn or deducted from a recycle content inventory. The amount of the deduction and/or applied to the PIA can correspond to any of the method e.g., a mass balance approach.

[0125] In an embodiment, a Recycle PIA can be made by having a recycle content inventory, and reacting a reactant in a synthetic process to make PIA, withdrawing an allotment from the recycle content inventory having a recycle content value, and applying the recycle content value to the PIA to thereby obtain a Recycle PIA. The amount of allotment deducted from inventory is flexible and will depend on the amount of recycle content applied to the PIA. It should be at least sufficient to correspond with at least a portion if not the entire amount of recycle content applied to the PIA. The recycle content allotment applied to the PIA does not have to have its origin in r-pyoil, and instead can have its origin in any other method of generating allotments from recycle waste, such as through methanolysis or gasification of recycle waste, provided that the recycle content inventory also contains an allotment or has an allotment deposit having its origin in r-pyoil. In one embodiment or in combination with any mentioned embodiments, however, the recycle content allotment applied to the PIA is an allotment obtained from r-pyoil.

[0126] The following are examples of applying a recycle content to PIA or to non-recycle olefin-containing effluents or compounds therein:

[0127] 1. A PIA manufacturer applies at least a portion of an allotment to a PIA to obtain Recycle PIA where the allotment is associated with r-pyoil and the reactant used to make the PIA did not contain any recycle content; or

[0128] 2. A PIA manufacturer applies at least a portion of an allotment to PIA to obtain Recycle PIA, where the

allotment is obtained from a recycle content reactant, whether or not such reactant volume is used to make the Recycle PIA; or

[0129] 3. A PIA manufacturer applies at least a portion of an allotment to a PIA to make Recycle PIA where the allotment is obtained from r-pyoil, and:

[0130] a. all of the recycle content in the r-pyoil is applied to determine the amount of recycle content in the Recycle PIA, or

[0131] b. only a portion of the recycle content in the r-pyoil feedstock is applied to determine the amount of recycle content in the Recycle PIA, the remainder stored in a recycle content inventory for future use or for application to other PIA, or to increase the recycle content on an existing Recycle PIA, or a combination thereof, or

[0132] c. none of the recycle content in the r-pyoil feedstock is applied to the PIA and instead is stored in an inventory, and a recycle content from any source or origin is deducted from the inventory and applied to PIA to make Recycle PIA; or

[0133] 4. A Recycle PIA manufacturer applies at least a portion of an allotment to a reactant used to make a PIA to thereby obtain a Recycle PIA, where the allotment was obtained with the transfer or purchase of the same reactant used to make the PIA and the allotment is associated with the recycle content in a reactant; or

[0134] 5. A Recycle PIA manufacturer applies at least a portion of an allotment to a reactant used to make a PIA to thereby obtain a Recycle PIA, where the allotment was obtained with the transfer or purchase of the same reactant used to make the PIA and the allotment is not associated with the recycle content in a reactant but rather on the recycle content of a monomer used to make the reactant; or

[0135] 6. A Recycle PIA manufacturer applies at least a portion of an allotment to a reactant used to make a PIA to thereby obtain a Recycle PIA, where the allotment was not obtained with the transfer or purchase of the reactant and the allotment is associated with the recycle content in the reactant; or

[0136] 7. A Recycle PIA manufacturer applies at least a portion of an allotment to a reactant used to make a PIA to thereby obtain a Recycle PIA, where the allotment was not obtained with the transfer or purchase of the reactant and the allotment is not associated with the recycle content in the reactant but rather with the recycle content of any monomers used to make the reactant; or

[0137] 8. A Recycle PIA manufacturer obtains an allotment having its origin r-pyoil, and:

[0138] a. no portion of the allotment is applied to a reactant to make PIA and instead at least a portion of the allotment is applied to the PIA to make a Recycle PIA; or

[0139] b. less than the entire portion is applied to a reactant used to make PIA and the remainder is stored in inventory or is applied to future made PIA or is applied to existing Recycle PIA in inventory to increase its recycle content value.

[0140] In one embodiment or in combination with any mentioned embodiments, the Recycle PIA, or articles made thereby, can be offered for sale or sold as Recycle PIA containing or obtained with recycle content. The sale or offer

for sale can be accompanied with a certification or representation of the recycle content claim made in association with the Recycle PIA.

[0141] The designation of at least a portion of the Recycle PIA or olefin-containing effluent as corresponding to at least a portion of the allotment (e.g., allocation or credit) can occur through a variety of means and according to the system employed by the Recycle PIA manufacturer or the olefin-containing effluent manufacturer, which can vary from manufacturer to manufacturer. For example, the designation can occur internally merely through a log entry in the books or files of the manufacturer or other inventory software program, or through an advertisement or statement on a specification, on a package, on the product, by way of a logo associated with the product, by way of a certification declaration sheet associated with a product sold, or through formulas that compute the amount deducted from inventory relative to the amount of recycle content applied to a product.

[0142] Optionally, the Recycle PIA can be sold. In one embodiment or in combination with any mentioned embodiments, there is provided a method of offering to sell or selling polymer and/or articles by:

[0143] a. A Recycle PIA manufacturer or an olefin-containing effluent manufacturer, or any among their Family of Entities (collectively the Manufacturer) obtains or generates a recycle content allotment, and the allotment can be obtained by any of the means described herein and can be deposited into a recycle content inventory, the recycle content allotment having its origin in r-pyoil,

[0144] b. converting a reactant in a synthetic process to make PIA, and the reactant can be any reactant or a r-reactant,

[0145] c. designating (e.g., assigning or associating) a recycle content to at least a portion of the PIA from a recycle content inventory to make a Recycle PIA, where the inventory contains at least one entry that is an allotment associated with r-pyoil. The designation can be the amount of allotment deducted from inventory, or the amount of recycle content declared or determined by the Recycle PIA manufacturer in its accounts. Thus, the amount of recycle content does not necessarily have to be applied to the Recycle PIA product in a physical fashion. The designation can be an internal designation to or by the Manufacturer or a service provider in contractual relationship to the Manufacturer, and

[0146] d. offering to sell or selling the Recycle PIA as containing or obtained with recycle content corresponding at least in part with such designation. The amount of recycle content represented as contained in the Recycle PIA sold or offered for sale has a relationship or linkage to the designation. The amount of recycle content can be a 1:1 relationship in the amount of recycle content declared on a Recycle PIA offered for sale or sold and the amount of recycle content assigned or designated to the Recycle PIA by the Recycle PIA manufacturer.

[0147] The steps described need not be sequential and can be independent from each other. For example, the step a) of obtaining an allotment and the step of making Recycle PIA can be simultaneous.

[0148] As used throughout, the step of deducting an allotment from a recycle content inventory does not require its application to a Recycle PIA product. The deduction also does not mean that the quantity disappears or is removed from the inventory logs. A deduction can be an adjustment of an entry, a withdrawal, an addition of an entry as a debit, or any other algorithm that adjusts inputs and outputs based on an amount recycle content associated with a product and one or a cumulative amount of allotments on deposit in the inventory. For example, a deduction can be a simple step of a reducing/debit entry from one column and an addition/credit to another column within the same program or books, or an algorithm that automates the deductions and entries/additions and/or applications or designations to a product slate. The step of applying an allotment to a PIA where such allotment was deducted from inventory also does not require the allotment to be applied physically to a Recycle PIA product or to any document issued in association with the Recycle PIA product sold. For example, a Recycle PIA manufacturer may ship Recycle PIA product to a customer and satisfy the "application" of the allotment to the Recycle PIA product by electronically transferring a recycle content credit to the customer.

[0149] There is also provided a use for r-pyoil, the use including converting r-pyoil in a gas cracker furnace to make an olefin-containing effluent.

[0150] There is also provided a use for a r-pyoil that includes converting a reactant in a synthetic process to make a PIA and applying at least a portion of an allotment to the PIAPIA, where the allotment is associated with r-pyoil or has its origin in an inventory of allotments where at least one deposit made into the inventory is associated with r-pyoil.

[0151] In one embodiment or in combination with any mentioned embodiments, there is provided a PIAPIA that is obtained by any of the methods described above.

[0152] The reactant can be stored in a storage vessel and transferred to a Recycle PIA manufacturing facility by way of truck, pipe, or ship, or as further described below, the olefin-containing effluent production facility can be integrated with the PIA facility. The reactant may be shipped or transferred to the operator or facility that makes the polymer and/or article.

[0153] In an embodiment, the process for making Recycle PIA can be an integrated process. One such example is a process to make Recycle PIA by:

[0154] a. cracking r-pyoil to make an olefin-containing effluent olefin-containing effluent; and

[0155] b. separating compounds in said olefin-containing effluent to obtain a separated compound; and

[0156] c. reacting any reactant in a synthetic process to make a PIA;

[0157] d. depositing an allotment into an inventory of allotments, said allotment originating from r-pyoil; and

[0158] e. applying any allotment from said inventory to the PIA to thereby obtain a Recycle PIA.

[0159] In one embodiment or in combination with any mentioned embodiments, one may integrate two or more facilities and make Recycle PIA. The facilities to make Recycle PIA, or the olefin-containing effluent, can be stand-alone facilities or facilities integrated to each other. For example, one may establish a system of producing and consuming a reactant, as follows:

[0160] a. provide an olefin-containing effluent manufacturing facility configured to produce a reactant;

[0161] b. provide a PIA manufacturing facility having a reactor configured to accept a reactant from the olefin-containing effluent manufacturing facility; and

[0162] c. a supply system providing fluid communication between these two facilities and capable of supplying a reactant from the olefin-containing effluent manufacturing facility to the PIA manufacturing facility,

wherein the olefin-containing effluent manufacturing facility generates or participates in a process to generate allotments and cracks r-pyoil, and:

[0163] (i) said allotments are applied to the reactants or to the PIA, or

[0164] (ii) are deposited into an inventory of allotments, and optionally an allotment is withdrawn from the inventory and applied to the reactants or to the PIA.

[0165] The Recycle PIA manufacturing facility can make Recycle PIA by accepting any reactant from the olefin-containing effluent manufacturing facility and applying a recycle content to Recycle PIA made with the reactant by deducting allotments from its inventory and applying them to the PIA.

[0166] In one embodiment or in combination with any mentioned embodiments, there is also provided a system for producing Recycle PIA as follows:

[0167] a. provide an olefin-containing effluent manufacturing facility configured to produce an output composition comprising an olefin-containing effluent;

[0168] b. provide a reactant manufacturing facility configured to accept a compound separated from the olefin-containing effluent and making, through a reaction scheme one or more downstream products of said compound to make an output composition comprising a reactant;

[0169] c. provide a PIA manufacturing facility having a reactor configured to accept a reactant and making an output composition comprising PIA; and

[0170] d. a supply system providing fluid communication between at least two of these facilities and capable of supplying the output composition of one manufacturing facility to another one or more of said manufacturing facilities.

[0171] The PIA manufacturing facility can make Recycle PIA. In this system, the olefin-containing effluent manufacturing facility can have its output in fluid communication with the reactant manufacturing facility which in turn can have its output in fluid communication with the PIA manufacturing facility. Alternatively, the manufacturing facilities of a) and b) alone can be in fluid communication, or only b) and c). In the latter case, the PIA manufacturing facility can make Recycle PIA by deducting allotments from its recycle content inventory and applying them to the PIA. The allotments obtained and stored in inventory can be obtained by any of the methods described above,

[0172] The fluid communication can be gaseous or liquid or both. The fluid communication need not be continuous and can be interrupted by storage tanks, valves, or other purification or treatment facilities, so long as the fluid can be transported from the manufacturing facility to the subsequent facility through an interconnecting pipe network and without the use of truck, train, ship, or airplane. Further, the facilities may share the same site, or in other words, one site may contain two or more of the facilities. Additionally, the facilities may also share storage tank sites, or storage tanks

for ancillary chemicals, or may also share utilities, steam or other heat sources, etc., yet also be considered as discrete facilities since their unit operations are separate. A facility will typically be bounded by a battery limit.

[0173] In one embodiment or in combination with any mentioned embodiments, the integrated process includes at least two facilities co-located within 5, or within 3, or within 2, or within 1 mile of each other (measured as a straight line). In one embodiment or in combination with any mentioned embodiments, at least two facilities are owned by the same Family of Entities.

[0174] In an embodiment, there is also provided an integrated Recycle PIA generating and consumption system. This system includes:

[0175] a. provide an olefin-containing effluent manufacturing facility configured to produce an output composition comprising an olefin-containing effluent;

[0176] b. provide a reactant manufacturing facility configured to accept a compound separated from the olefin-containing effluent and making, through a reaction scheme one or more downstream products of said compound to make an output composition comprising a reactant;

[0177] c. provide a PIA manufacturing facility having a reactor configured to accept a reactant and making an output composition comprising PIA; and

[0178] d. a piping system interconnecting at least two of said facilities, optionally with intermediate processing equipment or storage facilities, capable of taking off the output composition from one facility and accept said output at any one or more of the other facilities.

[0179] The system does not necessarily require a fluid communication between the two facilities, although fluid communication is desirable. For example, the compound separated from the olefin-containing effluent can be delivered to the reactant facility through the interconnecting piping network that can be interrupted by other processing equipment, such as treatment, purification, pumps, compression, or equipment adapted to combine streams, or storage facilities, all containing optional metering, valving, or interlock equipment. The equipment can be fixed to the ground or fixed to structures that are fixed to the ground. The interconnecting piping does not need to connect to the reactant reactor or the cracker, but rather to a delivery and receiving point at the respective facilities. The interconnecting pipework need not connect all three facilities to each other, but rather the interconnecting pipework can be between facilities a)-b), or b)-c), or between a)-b)-c).

[0180] There is also provided a circular manufacturing process comprising:

[0181] 1. providing a r-pyoil, and

[0182] 2. cracking the r-pyoil to produce an olefin-containing effluent, and

[0183] (i) reacting a compound separated from said olefin-containing effluent to make a Recycle PIA, or

[0184] (ii) associating a recycle content allotment, obtained from said r-pyoil, to the PIA made from compounds separated from a non-recycle olefin-containing effluent, to produce a Recycle PIA; and

[0185] 3. taking back at least a portion of any of said Recycle PIA or any other articles, compounds, or polymer made from said Recycle PIA, as a feedstock to make said r-pyoil.

[0186] In the above described process, an entirely circular or closed loop process is provided in which Recycle PIA can be recycled multiple times.

[0187] Examples of articles that are included in PIA are fibers, yarns, tow, continuous filaments, staple fibers, rovings, fabrics, textiles, flake, film (e.g., polyolefin films), sheet, compounded sheet, plastic containers, and consumer articles.

[0188] In one embodiment or in combination with any mentioned embodiments, the Recycle PIA is a polymer or article of the same family or classification of polymers or articles used to make r-pyoil.

[0189] As used herein, the terms “recycled waste,” “waste stream,” and “recycled waste stream” are used interchangeably to mean any type of waste or waste-containing stream that is reused in a production process, rather than being permanently disposed of (e.g., in a landfill or incinerator). The recycled waste stream is a flow or accumulation of waste from industrial and consumer sources that is at least in part recovered. A recycled waste stream includes materials, products, and articles (collectively “material(s)” when used alone). Waste materials can be solid or liquid. Examples of a solid waste stream include plastics, rubber (including tires), textiles, wood, biowaste, modified celluloses, wet laid products, and any other material capable of being pyrolyzed. Examples of liquid waste streams include industrial sludge, oils (including those derived from plants and petroleum), recovered lube oil, or vegetable oil or animal oil, and any other chemical streams from industrial plants.

[0190] In an embodiment or in combination with any embodiment mentioned herein or in combination with any of the mentioned embodiments, the recycled waste stream that is pyrolyzed includes a stream containing at least in part post-industrial, or post-consumer, or both a post-industrial and post-consumer materials. In an embodiment or in combination with any embodiment mentioned herein or in combination with any of the mentioned embodiments, a post-consumer material is one that has been used at least once for its intended application for any duration of time regardless of wear, or has been sold to an end use customer, or which is discarded into a recycle bin by any person or entity other than a manufacturer or business engaged in the manufacture or sale of the material. In an embodiment or in combination with any embodiment mentioned herein or in combination with any of the mentioned embodiments, a post-industrial material is one which has been created and has not been used for its intended application, or has not been sold to the end use customer, or discarded by a manufacturer or any other entity engaged in the sale of the material. Examples of post-industrial materials include rework, regrind, scrap, trim, out of specification materials, and finished materials transferred from a manufacturer to any downstream customer (e.g., manufacturer to wholesaler to distributor) but not yet used or sold to the end use customer.

[0191] The form of the recycled waste stream fed to a pyrolysis unit is not limited, and can include any of the forms of articles, products, materials, or portions thereof. A portion of an article can take the form of sheets, extruded shapes, moldings, films, laminates, foam pieces, chips, flakes, particles, agglomerates, briquettes, powder, shredded pieces, long strips, or randomly shaped pieces having a wide

variety of shapes, or any other form other than the original form of the article and adapted to feed a pyrolysis unit.

[0192] In an embodiment or in combination with any embodiment mentioned herein or in combination with any of the mentioned embodiments, the waste material is size reduced. Size reduction can occur through any means, including chopping, shredding, harrowing, confrication, pulverizing, cutting a feedstock, molding, compression, or dissolution in a solvent.

[0193] Recycled waste plastics can be isolated as one type of polymer stream or may be a stream of mixed waste plastics. The plastics can be any organic synthetic polymer that is solid at 25° C. at 1 atm. The plastics can be thermosetting, thermoplastic, or elastomeric plastics. Examples of plastics include high density polyethylene and copolymers thereof, low density polyethylene and copolymers thereof, polypropylene and copolymers thereof, other polyolefins, polystyrene, polyvinyl chloride (PVC), polyvinylidene chloride (PVDC), polyesters including polyethylene terephthalate, copolyesters and terephthalate copolyesters (e.g. containing residues of TMCD, CHDM, propylene glycol, or NPG monomers), polyethylene terephthalate, polyamides, poly(methyl methacrylate), polytetrafluoroethylene, acrylobutadienestyrene (ABS), polyurethanes, cellulose and derivatives thereof, epoxy, polyamides, phenolic resins, polyacetal, polycarbonates, polyphenylene-based alloys, polypropylene and copolymers thereof, polystyrene, styrenic compounds, vinyl based compounds, styrene acrylonitrile, thermoplastic elastomers, and urea based polymers and melamine containing polymers.

[0194] Suitable recycled waste plastics also include any of those having a resin ID code numbered 1-7 within the chasing arrow triangle established by the SPI. In an embodiment or in combination with any embodiment mentioned herein or in combination with any of the mentioned embodiments, the r-pyoil is made from a recycled waste stream at least a portion of which contains plastics that are not generally recycled. These would include plastics having numbers 3 (polyvinyl chloride), 5 (polypropylene), 6 (polystyrene), and 7 (other). In an embodiment or in combination with any embodiment mentioned herein or in combination with any of the mentioned embodiments, the waste stream that is pyrolyzed contains less than 10 weight percent, or not more than 5 weight percent, or not more than 3 weight percent, or not more than 2 weight percent, or not more than 1 weight percent, or not more than 0.5 weight percent, or not more than 0.2 weight percent, or not more than 0.1 weight percent, or not more and 0.05 weight percent plastics with a number 3 designation (polyvinyl chloride), or optionally plastics with a number 3 and 6 designation, or optionally with a number 3, 6 and 7 designation.

[0195] Examples of recycled rubber include natural and synthetic rubber. The form of the rubber is not limited and includes tires.

[0196] Examples of recycled waste wood include soft and hard woods, chipped, pulped, or as finished articles. The source of much waste wood is industrial, construction, or demolition.

[0197] Examples of recycled biowaste includes household biowaste (e.g., food), green or garden biowaste, and biowaste from the industrial food processing industry.

[0198] Examples of recycled textiles includes natural and/or synthetic fibers, rovings, yarns, nonwoven webs, cloth, fabrics and products made from or containing any of the

forementioned items. Textiles can be woven, knitted, knotted, stitched, tufted, pressing of fibers together such as would be done in a felting operation, embroidered, laced, crocheted, braided, or nonwoven webs and materials. Textiles include fabrics, and fibers separated from a textile or other product containing fibers, scrap or off spec fibers or yarns or fabrics, or any other source of loose fibers and yarns. A textile also includes staple fibers, continuous fibers, threads, tow bands, twisted and/or spun yarns, grey fabrics made from yarns, finished fabrics produced by wet processing gray fabrics, and garments made from the finished fabrics or any other fabrics. Textiles include apparels, interior furnishings, and industrial types of textiles.

[0199] Examples of recycled textiles in the apparel category (things humans wear or made for the body) include sports coats, suits, trousers and casual or work pants, shirts, socks, sportswear, dresses, intimate apparel, outerwear such as rain jackets, cold temperature jackets and coats, sweaters, protective clothing, uniforms, and accessories such as scarves, hats, and gloves. Examples of textiles in the interior furnishing category include furniture upholstery and slip-covers, carpets and rugs, curtains, bedding such as sheets, pillow covers, duvets, comforters, mattress covers; linens, tablecloths, towels, washcloths, and blankets. Examples of industrial textiles include transportation (auto, airplanes, trains, buses) seats, floor mats, trunk liners, and headliners; outdoor furniture and cushions, tents, backpacks, luggage, ropes, conveyor belts, calendar roll felts, polishing cloths, rags, soil erosion fabrics and geotextiles, agricultural mats and screens, personal protective equipment, bullet proof vests, medical bandages, sutures, tapes, and the like.

[0200] The recycled nonwoven webs can also be dry laid nonwoven webs. Examples of suitable articles that may be formed from dry laid nonwoven webs as described herein can include those for personal, consumer, industrial, food service, medical, and other types of end uses. Specific examples can include, but are not limited to, baby wipes, flushable wipes, disposable diapers, training pants, feminine hygiene products such as sanitary napkins and tampons, adult incontinence pads, underwear, or briefs, and pet training pads. Other examples include a variety of different dry or wet wipes, including those for consumer (such as personal care or household) and industrial (such as food service, health care, or specialty) use. Nonwoven webs can also be used as padding for pillows, mattresses, and upholstery, batting for quilts and comforters. In the medical and industrial fields, nonwoven webs of the present invention may be used for medical and industrial face masks, protective clothing, caps, and shoe covers, disposable sheets, surgical gowns, drapes, bandages, and medical dressings. Additionally, nonwoven webs may be used for environmental fabrics such as geotextiles and tarps, oil and chemical absorbent pads, as well as building materials such as acoustic or thermal insulation, tents, lumber and soil covers and sheeting. Nonwoven webs may also be used for other consumer end use applications, such as for, carpet backing, packaging for consumer, industrial, and agricultural goods, thermal or acoustic insulation, and in various types of apparel. The dry laid nonwoven webs may also be used for a variety of filtration applications, including transportation (e.g., automotive or aeronautical), commercial, residential, industrial, or other specialty applications. Examples can include filter elements for consumer or industrial air or liquid filters (e.g., gasoline, oil, water), including nanofiber webs used for

microfiltration, as well as end uses like tea bags, coffee filters, and dryer sheets. Further, nonwoven webs may be used to form a variety of components for use in automobiles, including, but not limited to, brake pads, trunk liners, carpet tufting, and under padding.

[0201] The recycled textiles can include single type or multiple type of natural fibers and/or single type or multiple type of synthetic fibers. Examples of textile fiber combinations include all natural, all synthetic, two or more type of natural fibers, two or more types of synthetic fibers, one type of natural fiber and one type of synthetic fiber, one type of natural fibers and two or more types of synthetic fibers, two or more types of natural fibers and one type of synthetic fibers, and two or more types of natural fibers and two or more types of synthetic fibers.

[0202] Examples of recycled wet laid products include cardboard, office paper, newsprint and magazine, printing and writing paper, sanitary, tissue/toweling, packaging/container board, specialty papers, apparel, bleached board, corrugated medium, wet laid molded products, unbleached Kraft, decorative laminates, security paper and currency, grand scale graphics, specialty products, and food and drink products.

[0203] Examples of modified cellulose include cellulose acetate, cellulose diacetate, cellulose triacetate, regenerated cellulose such as viscose, rayon, and Lyocel™ products, in any form, such as tow bands, staple fibers, continuous fibers, films, sheets, molded or stamped products, and contained in or on any article such as cigarette filter rods, ophthalmic products, screwdriver handles, optical films, and coatings.

[0204] Examples of recycled vegetable oil or animal oil include the oils recovered from animal processing facilities and waste from restaurants.

[0205] The source for obtaining recycled post-consumer or post-industrial waste is not limited and can include waste present in and/or separated from municipal solid waste streams ("MSW"). For example, an MSW stream can be processed and sorted to several discrete components, including textiles, fibers, papers, wood, glass, metals, etc. Other sources of textiles include those obtained by collection agencies, or by or for or on behalf of textile brand owners or consortiums or organizations, or from brokers, or from postindustrial sources such as scrap from mills or commercial production facilities, unsold fabrics from wholesalers or dealers, from mechanical and/or chemical sorting or separation facilities, from landfills, or stranded on docks or ships.

[0206] In an embodiment or in combination with any embodiment mentioned herein or in combination with any of the mentioned embodiments, the feed to the pyrolysis unit can comprise at least 30, or at least 35, or at least 40, or at least 45, or at least 50, or at least 55, or at least 60, or at least 65, or at least 70, or at least 75, or at least 80, or at least 85, or at least 90, or at least 95, or at least 99, in each case weight percent of at least one, or at least two, or at least three, or at least four, or at least five, or at least six different kinds of recycled waste. Reference to a "kind" is determined by resin ID code 1-7. In an embodiment or in combination with any embodiment mentioned herein or in combination with any of the mentioned embodiments, the feed to the pyrolysis unit contains less than 25, or not more than 20, or not more than 15, or not more than 10, or not more than 5, or not more than 1, in each case weight percent of polyvinyl chloride and/or polyethylene terephthalate. In an embodiment or in combination with any embodiment mentioned herein or in com-

bination with any of the mentioned embodiments, the recycled waste stream contains at least one, two, or three kinds of plasticized plastics.

[0207] FIG. 2 depicts an exemplary pyrolysis system 110 that may be employed to at least partially convert one or more recycled waste, particularly recycled plastic waste, into various useful pyrolysis-derived products. It should be understood that the pyrolysis system shown in FIG. 2 is just one example of a system within which the present disclosure can be embodied. The present disclosure may find application in a wide variety of other systems where it is desirable to efficiently and effectively pyrolyze recycled waste, particularly recycled plastic waste, into various desirable end products. The exemplary pyrolysis system illustrated in FIG. 2 will now be described in greater detail.

[0208] As shown in FIG. 2, the pyrolysis system 110 may include a waste plastic source 112 for supplying one or more waste plastics to the system 110. The plastic source 112 can be, for example, a hopper, storage bin, railcar, over-the-road trailer, or any other device that may hold or store waste plastics. In an embodiment or in combination with any of the embodiments mentioned herein, the waste plastics supplied by the plastic source 112 can be in the form of solid particles, such as chips, flakes, or a powder. Although not depicted in FIG. 2, the pyrolysis system 110 may also comprise additional sources of other types of recycled wastes that may be utilized to provide other feed types to the system 110.

[0209] In an embodiment or in combination with any of the embodiments mentioned herein, the waste plastics can include one or more post-consumer waste plastic such as, for example, high density polyethylene, low density polyethylene, polypropylene, other polyolefins, polystyrene, polyvinyl chloride (PVC), polyvinylidene chloride (PVDC), polyethylene terephthalate, polyamides, poly(methyl methacrylate), polytetrafluoroethylene, or combinations thereof. In an embodiment or in combination with any of the embodiments mentioned herein, the waste plastics may include high density polyethylene, low density polyethylene, polypropylene, or combinations thereof. As used herein, “post-consumer” refers to non-virgin plastics that have been previously introduced into the consumer market.

[0210] In an embodiment or in combination with any of the embodiments mentioned herein, a waste plastic-containing feed may be supplied from the plastic source 112. In an embodiment or in combination with any of the embodiments mentioned herein, the waste plastic-containing feed can comprise, consist essentially of, or consist of high density polyethylene, low density polyethylene, polypropylene, other polyolefins, polystyrene, polyvinyl chloride (PVC), polyvinylidene chloride (PVDC), polyethylene terephthalate, polyamides, poly(methyl methacrylate), polytetrafluoroethylene, or combinations thereof.

[0211] In an embodiment or in combination with any of the embodiments mentioned herein, the waste plastic-containing feed can comprise at least 30, or at least 35, or at least 40, or at least 45, or at least 50, or at least 55, or at least 60, or at least 65, or at least 70, or at least 75, or at least 80, or at least 85, or at least 90, or at least 95, or at least 99, in each case weight percent of at least one, two, three, or four different kinds of waste plastic. In an embodiment or in combination with any of the embodiments mentioned herein, the plastic waste may comprise not more than 25, or not more than 20, or not more than 15, or not more than 10, or not more than 5, or not more than 1, in each case weight

percent of polyvinyl chloride and/or polyethylene terephthalate. In an embodiment or in combination with any of the embodiments mentioned herein, the waste plastic-containing feed can comprise at least one, two, or three kinds of plasticized plastics. Reference to a “kind” is determined by resin ID code 1-7.

[0212] As depicted in FIG. 2, the solid waste plastic feed from the plastic source 112 can be supplied to a feedstock pretreatment unit 114. While in the feedstock pretreatment unit 114, the introduced waste plastics may undergo a number of pretreatments to facilitate the subsequent pyrolysis reaction. Such pretreatments may include, for example, washing, mechanical agitation, flotation, size reduction or any combination thereof. In an embodiment or in combination with any of the embodiments mentioned herein, the introduced plastic waste may be subjected to mechanical agitation or subjected to size reduction operations to reduce the particle size of the plastic waste. Such mechanical agitation can be supplied by any mixing, shearing, or grinding device known in the art which may reduce the average particle size of the introduced plastics by at least 10, or at least 25, or at least 50, or at least 75, in each case percent.

[0213] Next, the pretreated plastic feed can be introduced into a plastic feed system 116. The plastic feed system 116 may be configured to introduce the plastic feed into the pyrolysis reactor 118. The plastic feed system 116 can comprise any system known in the art that is capable of feeding the solid plastic feed into the pyrolysis reactor 118. In an embodiment or in combination with any of the embodiments mentioned herein, the plastic feed system 116 can comprise a screw feeder, a hopper, a pneumatic conveyance system, a mechanic metal train or chain, or combinations thereof.

[0214] While in the pyrolysis reactor 118, at least a portion of the plastic feed may be subjected to a pyrolysis reaction that produces a pyrolysis effluent comprising a pyrolysis oil (e.g., r-pyoil) and a pyrolysis gas (e.g., r-pyrolysis gas). The pyrolysis reactor 118 can be, for example, an extruder, a tubular reactor, a tank, a stirred tank reactor, a riser reactor, a fixed bed reactor, a fluidized bed reactor, a rotary kiln, a vacuum reactor, a microwave reactor, an ultrasonic or supersonic reactor, or an autoclave, or a combination of these reactors.

[0215] Generally, pyrolysis is a process that involves the chemical and thermal decomposition of the introduced feed. Although all pyrolysis processes may be generally characterized by a reaction environment that is substantially free of oxygen, pyrolysis processes may be further defined, for example, by the pyrolysis reaction temperature within the reactor, the residence time in the pyrolysis reactor, the reactor type, the pressure within the pyrolysis reactor, and the presence or absence of pyrolysis catalysts.

[0216] In an embodiment or in combination with any of the embodiments mentioned herein, the pyrolysis reaction can involve heating and converting the plastic feed in an atmosphere that is substantially free of oxygen or in an atmosphere that contains less oxygen relative to ambient air. In an embodiment or in combination with any of the embodiments mentioned herein, the atmosphere within the pyrolysis reactor 118 may comprise not more than 5, or not more than 4, or not more than 3, or not more than 2, or not more than 1, or not more than 0.5, in each case weight percent of oxygen gas.

[0217] In an embodiment or in combination with any of the embodiments mentioned herein, the pyrolysis process may be carried out in the presence of an inert gas, such as nitrogen, carbon dioxide, and/or steam. Additionally, or alternatively, in an embodiment or in combination with any of the embodiments mentioned herein, the pyrolysis process can be carried out in the presence of a reducing gas, such as hydrogen and/or carbon monoxide.

[0218] In an embodiment or in combination with any of the embodiments mentioned herein, the temperature in the pyrolysis reactor **118** can be adjusted to as to facilitate the production of certain end products. In an embodiment or in combination with any of the embodiments mentioned herein, the pyrolysis temperature in the pyrolysis reactor **118** can be at least 325° C., or at least 350° C., or at least 375° C., or at least 400° C., or at least 425° C., or at least 450° C., or at least 475° C., or at least 500° C., or at least 525° C., or at least 550° C., or at least 575° C., or at least 600° C., or at least 625° C., or at least 650° C., or at least 675° C., or at least 700° C., or at least 725° C., or at least 750° C., or at least 775° C., or at least 800° C. Additionally, or alternatively, in an embodiment or in combination with any of the embodiments mentioned herein, the pyrolysis temperature in the pyrolysis reactor **118** can be not more than 1,100° C., or not more than 1,050° C., or not more than 1,000° C., or not more than 950° C., or not more than 900° C., or not more than 850° C., or not more than 800° C., or not more than 750° C., or not more than 700° C., or not more than 650° C., or not more than 600° C., or not more than 550° C., or not more than 525° C., or not more than 500° C., or not more than 475° C., or not more than 450° C., or not more than 425° C., or not more than 400° C. In an embodiment or in combination with any of the embodiments mentioned herein, the pyrolysis temperature in the pyrolysis reactor **118** can range from 325 to 1,100° C., 350 to 900° C., 350 to 700° C., 350 to 550° C., 350 to 475° C., 500 to 1,100° C., 600 to 1,100° C., or 650 to 1,000° C.

[0219] In an embodiment or in combination with any of the embodiments mentioned herein, the residence times of the pyrolysis reaction can be at least 1, or at least 2, 3 or at least 4, in each case seconds, or at least 10, or at least 20, or at least 30, or at least 45, or at least 60, or at least 75, or at least 90, in each case minutes. Additionally, or alternatively, in an embodiment or in combination with any of the embodiments mentioned herein, the residence times of the pyrolysis reaction can be not more than 6 hours, or not more than 5, or not more than 4, or not more than 3, 2 or not more than 1, or not more than 0.5, 1, or not more than 0.5, in each case hours. In an embodiment or in combination with any of the embodiments mentioned herein, the residence times of the pyrolysis reaction can range from 30 minutes to 4 hours, or 30 minutes to 3 hours, or 1 hour to 3 hours, or 1 hour to 2 hours.

[0220] In an embodiment or in combination with any of the embodiments mentioned herein, the pressure within the pyrolysis reactor **118** can be maintained at a pressure of at least 0.1, or at least 0.2, or at least 0.3, in each case bar and/or not more than 60, or not more than 50, or not more than 40, or not more than 30, or not more than 20, or not more than 10, or not more than 8, or not more than 5, or not more than 2, or not more than 1.5, or not more than 1.1, in each case bar. In an embodiment or in combination with any of the embodiments mentioned herein, the pressure within the pyrolysis reactor **18** can be maintained at about atmo-

spheric pressure or within the range of 0.1 to 100 bar, or 0.1 to 60 bar, or 0.1 to 30 bar, or 0.1 to 10 bar, or 1.5 bar, 0.2 to 1.5 bar, or 0.3 to 1.1 bar.

[0221] In an embodiment or in combination with any of the embodiments mentioned herein, a pyrolysis catalyst may be introduced into the plastic feed prior to introduction into the pyrolysis reactor **118** and/or introduced directly into the pyrolysis reactor **118** to produce an r-catalytic pyoil, or an r-pyoil made by a catalytic pyrolysis process. In an embodiment or in combination with any embodiment mentioned herein or in combination with any of the embodiments mentioned herein, the catalyst can comprise: (i) a solid acid, such as a zeolite (e.g., ZSM-5, Mordenite, Beta, Ferrierite, and/or zeolite-Y); (ii) a super acid, such as sulfonated, phosphated, or fluorinated forms of zirconia, titania, alumina, silica-alumina, and/or clays; (iii) a solid base, such as metal oxides, mixed metal oxides, metal hydroxides, and/or metal carbonates, particularly those of alkali metals, alkaline earth metals, transition metals, and/or rare earth metals; (iv) hydrotalcite and other clays; (v) a metal hydride, particularly those of alkali metals, alkaline earth metals, transition metals, and/or rare earth metals; (vi) an alumina and/or a silica-alumina; (vii) a homogeneous catalyst, such as a Lewis acid, a metal tetrachloroaluminate, or an organic ionic liquid; (viii) activated carbon; or (ix) combinations thereof.

[0222] In an embodiment or in combination with any of the embodiments mentioned herein, the pyrolysis reaction in the pyrolysis reactor **118** occurs in the substantial absence of a catalyst, particularly the above-referenced catalysts. In such embodiments, a non-catalytic, heat-retaining inert additive may still be introduced into the pyrolysis reactor **118**, such as sand, in order to facilitate the heat transfer within the reactor **118**.

[0223] In an embodiment or in combination with any of the embodiments mentioned herein, the pyrolysis reaction in the pyrolysis reactor **118** may occur in the substantial absence of a pyrolysis catalyst, at a temperature in the range of 350 to 550° C., at a pressure ranging from 0.1 to 60 bar, and at a residence time of 0.2 seconds to 4 hours, or 0.5 hours to 3 hours.

[0224] Referring again to FIG. 2, the pyrolysis effluent **120** exiting the pyrolysis reactor **118** generally comprises pyrolysis gas, pyrolysis vapors, and residual solids. As used herein, the vapors produced during the pyrolysis reaction may interchangeably be referred to as a “pyrolysis oil,” which refers to the vapors when condensed into their liquid state. In an embodiment or in combination with any of the embodiments mentioned herein, the solids in the pyrolysis effluent **20** may comprise particles of char, ash, unconverted plastic solids, other unconverted solids from the feedstock, and/or spent catalyst (if a catalyst is utilized).

[0225] In an embodiment or in combination with any of the embodiments mentioned herein, the pyrolysis effluent **120** may comprise at least 20, or at least 25, or at least 30, or at least 40, or at least 45, or at least 50, or at least 55, or at least 60, or at least 65, or at least 70, or at least 75, or at least 80, in each case weight percent of the pyrolysis vapors, which may be subsequently condensed into the resulting pyrolysis oil (e.g., r-pyoil). Additionally, or alternatively, in an embodiment or in combination with any of the embodiments mentioned herein, the pyrolysis effluent **120** may comprise not more than 99, or not more than 95, or not more than 90, or not more than 85, or not more than 80, or not more than 75, or not more than 70, or not more than

65, or not more than 60, or not more than 55, or not more than 50, or not more than 45, or not more than 40, or not more than 35, or not more than 30, in each case weight percent of the pyrolysis vapors. In an embodiment or in combination with any of the embodiments mentioned herein, the pyrolysis effluent **120** may comprise in the range of 20 to 99 weight percent, 40 to 90 weight percent, or 55 to 90 weight percent of the pyrolysis vapors.

[0226] In an embodiment or in combination with any of the embodiments mentioned herein, the pyrolysis effluent **120** may comprise at least 1, or at least 5, or at least 6, or at least 7, or at least 8, or at least 9, or at least 10, or at least 11, or at least 12, in each case weight percent of the pyrolysis gas (e.g., r-pyrolysis gas). As used herein, a “pyrolysis gas” refers to a composition that is produced via pyrolysis and is a gas at standard temperature and pressure (STP). Additionally, or alternatively, in an embodiment or in combination with any of the embodiments mentioned herein, the pyrolysis effluent **20** may comprise not more than 90, or not more than 85, or not more than 80, or not more than 75, or not more than 70, or not more than 65, or not more than 60, or not more than 55, or not more than 50, or not more than 45, or not more than 40, or not more than 35, or not more than 30, or not more than 25, or not more than 20, or not more than 15, in each case weight percent of the pyrolysis gas. In an embodiment or in combination with any of the embodiments mentioned herein, the pyrolysis effluent **120** may comprise 1 to 90 weight percent, or 5 to 60 weight percent, or 10 to 60 weight percent, or 10 to 30 weight percent, or 5 to 30 weight percent of the pyrolysis gas.

[0227] In an embodiment or in combination with any of the embodiments mentioned herein, the pyrolysis effluent **120** may comprise not more than 15, or not more than 10, or not more than 9, or not more than 8, or not more than 7, or not more than 6, or not more than 5, or not more than 4 or not more than 3, in each case weight percent of the residual solids.

[0228] In one embodiment or in combination of any mentioned embodiments, there is provided a cracker feed stock composition containing pyrolysis oil (r-pyoil), and the r-pyoil composition contains recycle content catalytic pyrolysis oil (r-catalytic pyoil) and a recycle content thermal pyrolysis oil (r-thermal pyoil). An r-thermal pyoil is pyoil made without the addition of a pyrolysis catalyst. The cracker feedstock can include at least 5, 10, 15, or 20 weight percent r-catalytic pyoil, optionally that has been hydrotreated. The r-pyoil containing t-thermal pyoil and r-catalytic pyoil can be cracked according to any of the processes described herein to provide an olefin-containing effluent stream. The r-catalytic pyoil can be blended with r-thermal pyoil to form a blended stream cracked in the cracker unit. Optionally, the blended stream can contain not more than 10, 5, 3, 2, 1 weight percent of r-catalytic pyoil that has not been hydrotreated.

[0229] In one embodiment or in combination with any mentioned embodiment, the r-pyoil does not contain r-catalytic pyoil.

[0230] As depicted in FIG. 2, the conversion effluent **120** from the pyrolysis reactor **118** can be introduced into a solids separator **122**. The solids separator **122** can be any conventional device capable of separating solids from gas and vapors such as, for example, a cyclone separator or a gas filter or combination thereof. In an embodiment or in combination with any of the embodiments mentioned herein, the

solids separator **122** removes a substantial portion of the solids from the conversion effluent **120**. In an embodiment or in combination with any of the embodiments mentioned herein, at least a portion of the solid particles **24** recovered in the solids separator **122** may be introduced into an optional regenerator **126** for regeneration, generally by combustion. After regeneration, at least a portion of the hot regenerated solids **128** can be introduced directly into the pyrolysis reactor **118**. In an embodiment or in combination with any of the embodiments mentioned herein, at least a portion of the solid particles **124** recovered in the solids separator **122** may be directly introduced back into the pyrolysis reactor **118**, especially if the solid particles **124** contain a notable amount of unconverted plastic waste. Solids can be removed from the regenerator **126** through line **145** and discharged out of the system.

[0231] Turning back to FIG. 2, the remaining gas and vapor conversion products **130** from the solids separator **122** may be introduced into a fractionator **132**. In the fractionator **132**, at least a portion of the pyrolysis oil vapors may be separated from the pyrolysis gas to thereby form a pyrolysis gas product stream **134** and a pyrolysis oil vapor stream **136**. Suitable systems to be used as the fractionator **132** may include, for example, a distillation column, a membrane separation unit, a quench tower, a condenser, or any other known separation unit known in the art. In an embodiment or in combination with any of the embodiments mentioned herein, any residual solids **146** accrued in the fractionator **132** may be introduced in the optional regenerator **126** for additional processing.

[0232] In an embodiment or in combination with any of the embodiments mentioned herein, at least a portion of the pyrolysis oil vapor stream **136** may be introduced into a quench unit **138** in order to at least partially quench the pyrolysis vapors into their liquid form (i.e., the pyrolysis oil). The quench unit **138** may comprise any suitable quench system known in the art, such as a quench tower. The resulting liquid pyrolysis oil stream **140** may be removed from the system **110** and utilized in the other downstream applications described herein. In an embodiment or in combination with any of the embodiments mentioned herein, the liquid pyrolysis oil stream **140** may not be subjected to any additional treatments, such as hydrotreatment and/or hydrogenation, prior to being utilized in any of the downstream applications described herein.

[0233] In an embodiment or in combination with any embodiment mentioned herein or in combination with any of the embodiments mentioned herein, at least a portion of the pyrolysis oil vapor stream **136** may be introduced into a hydroprocessing unit **142** for further refinement. The hydroprocessing unit **142** may comprise a hydrocracker, a catalytic cracker operating with a hydrogen feed stream, a hydrotreatment unit, and/or a hydrogenation unit. While in the hydroprocessing unit **142**, the pyrolysis oil vapor stream **136** may be treated with hydrogen and/or other reducing gases to further saturate the hydrocarbons in the pyrolysis oil and remove undesirable byproducts from the pyrolysis oil. The resulting hydroprocessed pyrolysis oil vapor stream **144** may be removed and introduced into the quench unit **138**. Alternatively, the pyrolysis oil vapor may be cooled, liquified, and then treated with hydrogen and/or other reducing gases to further saturate the hydrocarbons in the pyrolysis oil. In this case, the hydrogenation or hydrotreating is

performed in a liquid phase pyrolysis oil. No quench step is required in this embodiment post-hydrogenation or post-hydrotreating.

[0234] The pyrolysis system **110** described herein may produce a pyrolysis oil (e.g., r-pyoil) and pyrolysis gases (e.g., r-pyrolysis gas) that may be directly used in various downstream applications based on their desirable formulations. The various characteristics and properties of the pyrolysis oils and pyrolysis gases are described below. It should be noted that, while all of the following characteristics and properties may be listed separately, it is envisioned that each of the following characteristics and/or properties of the pyrolysis oils or pyrolysis gases are not mutually exclusive and may be combined and present in any combination.

[0235] The pyrolysis oil may predominantly comprise hydrocarbons having from 4 to 30 carbon atoms per molecule (e.g., C₄ to C₃₀ hydrocarbons). As used herein, the term “Cx” or “Cx hydrocarbon,” refers to a hydrocarbon compound including x total carbons per molecule, and encompasses all olefins, paraffins, aromatics, and isomers having that number of carbon atoms. For example, each of normal, iso, and tert butane and butene and butadiene molecules would fall under the general description “C₄.”

[0236] In an embodiment or in combination with any of the embodiments mentioned herein, the pyrolysis oil fed to the cracking furnace may have a C₄-C₃₀ hydrocarbon content of at least 55, or at least 60, or at least 65, or at least 70, or at least 75, or at least 80, or at least 85, or at least 90, or at least 95, in each case weight percent based on the weight of the pyrolysis oil.

[0237] In an embodiment or in combination with any of the embodiments mentioned herein, the pyrolysis oil fed to the furnace can predominantly comprise C₅-C₂₅, C₅-C₂₂, or C₅-C₂₀ hydrocarbons, or may comprise at least about 55, or at least 60, or at least 65, or at least 70, or at least 75, or at least 80, or at least 85, or at least 90, or at least 95, in each case weight percent of C₅-C₂₅, C₅-C₂₂, or C₅-C₂₀ hydrocarbons, based on the weight of the pyrolysis oil.

[0238] The gas furnace can tolerate a wide variety of hydrocarbon numbers in the pyrolysis oil feedstock, thereby avoiding the necessity for subjecting a pyrolysis oil feedstock to separation techniques to deliver a smaller or lighter hydrocarbon cut to the cracker furnace. In one embodiment or in any of the mentioned embodiments, the pyrolysis oil after delivery from a pyrolysis manufacturer is not subjected a separation process for separating a heavy hydrocarbon cut from a lighter hydrocarbon cut, relative to each other, prior to feeding the pyrolysis oil to a cracker furnace. The feed of pyrolysis oil to a gas furnace allows one to employ a pyrolysis oil that contains heavy tail ends or higher carbon numbers at or above 12. In one embodiment or in any of the mentioned embodiments, the pyrolysis oil fed to a cracker furnace is a C₅ to C₂₅ hydrocarbon stream containing at least 3 wt. %, or at least 5 wt. %, or at least 8 wt. %, or at least 10 wt. %, or at least 12 wt. %, or at least 15 wt. %, or at least 18 wt. %, or at least 20 wt. %, or at least 25 wt. % or at least 30 wt. %, or at least 35 wt. %, or at least 40 wt. %, or at least 45 wt. %, or at least 50 wt. %, or at least 55 wt. %, or at least 60 wt. % hydrocarbons within a range from C₁₂ to C₂₅, inclusive, or within a range of C₁₄ to C₂₅, inclusive, or within a range of C₁₆ to C₂₅, inclusive.

[0239] In an embodiment or in combination with any of the embodiments mentioned herein, the pyrolysis oil may

have a C₆ to C₁₂ hydrocarbon content of at least 10, or at least 15, or at least 20, or at least 25, or at least 30, or at least 35, or at least 40, or at least 45, or at least 50, or at least 55, in each case weight percent, based on the weight of the pyrolysis oil. Additionally, or alternatively, in an embodiment or in combination with any of the embodiments mentioned herein, the pyrolysis oil may have a C₆-C₁₂ hydrocarbon content of not more than 95, or not more than 90, or not more than 85, or not more than 80, or not more than 75, or not more than 70, or not more than 65, or not more than 60, in each case weight percent. In an embodiment or in combination with any of the embodiments mentioned herein, the pyrolysis oil may have a C₆-C₁₂ hydrocarbon content in the range of 10 to 95 weight percent, 20 to 80 weight percent, or 35 to 80 weight percent.

[0240] In an embodiment or in combination with any of the embodiments mentioned herein, the pyrolysis oil may have a C₁₃ to C₂₃ hydrocarbon content of at least 1, or at least 5, or at least 10, or at least 15, or at least 20, or at least 25, or at least 30, in each case weight percent. Additionally, or alternatively, in an embodiment or in combination with any of the embodiments mentioned herein, the pyrolysis oil may have a C₁₃ to C₂₃ hydrocarbon content of not more than 80, or not more than 75, or not more than 70, or not more than 65, or not more than 60, or not more than 55, or not more than 50, or not more than 45, or not more than 40, in each case weight percent. In an embodiment or in combination with any of the embodiments mentioned herein, the pyrolysis oil may have a C₁₃ to C₂₃ hydrocarbon content in the range of 1 to 80 weight percent, 5 to 65 weight percent, or 10 to 60 weight percent.

[0241] In an embodiment or in combination with any of the embodiments mentioned herein, the r-pyrolysis oil, or r-pyoil fed to a cracker furnace, or r-pyoil fed to a cracker furnace that, prior to feeding-pyoil, accepts a predominately C₂-C₄ feedstock (and the mention of r-pyoil or pyrolysis oil throughout includes any of these embodiments), may have a C₂₄₊ hydrocarbon content of at least 1, or at least 2, or at least 3, or at least 4, or at least 5, in each case weight percent. Additionally, or alternatively, in an embodiment or in combination with any of the embodiments mentioned herein, the pyrolysis oil may have a C₂₄₊ hydrocarbon content of not more than 15, or not more than 10, or not more than 9, or not more than 8, or not more than 7, or not more than 6, in each case weight percent. In an embodiment or in combination with any of the embodiments mentioned herein, the pyrolysis oil may have a C₂₄₊ hydrocarbon content in the range of 1 to 15 weight percent, 3 to 15 weight percent, 2 to 5 weight percent, or 5 to 10 weight percent.

[0242] The pyrolysis oil may also include various amounts of olefins, aromatics, and other compounds. In an embodiment or in combination with any of the embodiments mentioned herein, the pyrolysis oil includes at least 1, or at least 2, or at least 5, or at least 10, or at least 15, or at least 20, in each case weight percent olefins and/or aromatics. Additionally, or alternatively, in an embodiment or in combination with any of the embodiments mentioned herein, the pyrolysis oil may include not more than 50, or not more than 45, or not more than 40, or not more than 35, or not more than 30, or not more than 25, or not more than 20, or not more than 15, or not more than 10, or not more than 5, or not more than 2, or not more than 1, in each case weight percent olefins and/or aromatics.

[0243] In an embodiment or in combination with any of the embodiments mentioned herein, the pyrolysis oil may have an aromatic content of not more than 25, or not more than 20, or not more than 15, or not more than 14, or not more than 13, or not more than 12, or not more than 11, or not more than 10, or not more than 9, or not more than 8, or not more than 7, or not more than 6, or not more than 5, or not more than 4, or not more than 3, or not more than 2, or not more than 1, in each case weight percent. In one embodiment or in combination with any mentioned embodiments, the pyrolysis oil has an aromatic content that is not higher than 15, or not more than 10, or not more than 8, or not more than 6, in each case weight percent.

[0244] In an embodiment or in combination with any of the embodiments mentioned herein, the pyrolysis oil may have a naphthene content of at least 1, or at least 2, or at least 3, or at least 4, or at least 5, or at least 6, or at least 7, or at least 8, or at least 9, or at least 10, or at least 11, or at least 12, or at least 13, or at least 14, or at least 15, in each case weight percent. Additionally, or alternatively, in an embodiment or in combination with any of the embodiments mentioned herein, the pyrolysis oil may have a naphthene content of not more than 50, or not more than 45, or not more than 40, or not more than 35, or not more than 30, or not more than 25, or not more than 20, or not more than 10, or not more than 5, or not more than 2, or not more than 1, or not more than 0.5, or no detectable amount, in each case weight percent. In an embodiment or in combination with any of the embodiments mentioned herein, the pyrolysis oil may have a naphthene content of not more than 5, or not more than 2, or not more than 1 wt. %, or no detectable amount, or naphthenes. Alternatively, the pyrolysis oil may contain in the range of 1 to 50 weight percent, 5 to 50 weight percent, or 10 to 45 weight percent naphthenes, especially if the r-pyoil was subjected to a hydrotreating process.

[0245] In an embodiment or in combination with any of the embodiments mentioned herein, the pyrolysis oil may have a paraffin content of at least 25, or at least 30, or at least 35, or at least 40, or at least 45, or at least 50, in each case weight percent. Additionally, or alternatively, in an embodiment or in combination with any of the embodiments mentioned herein, the pyrolysis oil may have a paraffin content of not more than 90, or not more than 85, or not more than 80, or not more than 75, or not more than 70, or not more than 65, or not more than 60, or not more than 55, in each case weight percent. In an embodiment or in combination with any of the embodiments mentioned herein, the pyrolysis oil may have a paraffin content in the range of 25 to 90 weight percent, 35 to 90 weight percent, or 40 to 80, or 40-70, or 40-65 weight percent.

[0246] In an embodiment or in combination with any of the embodiments mentioned herein, the pyrolysis oil may have an n-paraffin content of at least 5, or at least 10, or at least 15, or at least 25, or at least 30, or at least 35, or at least 40, or at least 45, or at least 50, in each case weight percent. Additionally, or alternatively, in an embodiment or in combination with any of the embodiments mentioned herein, the pyrolysis oil may have an n-paraffin content of not more than 90, or not more than 85, or not more than 80, or not more than 75, or not more than 70, or not more than 65, or not more than 60, or not more than 55, in each case weight percent. In an embodiment or in combination with any of the embodiments mentioned herein, the pyrolysis oil may have

an n-paraffin content in the range of 25 to 90 weight percent, 35 to 90 weight percent, or 40-70, or 40-65, or 50 to 80 weight percent.

[0247] In an embodiment or in combination with any of the embodiments mentioned herein, the pyrolysis oil may have a paraffin to olefin weight ratio of at least 0.2:1, or at least 0.3:1, or at least 0.4:1, or at least 0.5:1, or at least 0.6:1, or at least 0.7:1, or at least 0.8:1, or at least 0.9:1, or at least 1:1. Additionally, or alternatively, in an embodiment or in combination with any of the embodiments mentioned herein, the pyrolysis oil may have a paraffin to olefin weight ratio not more than 3:1, or not more than 2.5:1, or not more than 2:1, or not more than 1.5:1, or not more than 1.4:1, or not more than 1.3:1. In an embodiment or in combination with any of the embodiments mentioned herein, the pyrolysis oil may have a paraffin to olefin weight ratio in the range of 0.2:1 to 5:1, or 1:1 to 4.5:1, or 1.5:1 to 5:1, or 1.5:1:4.5:1, or 0.2:1 to 4:1, or 0.2:1 to 3:1, 0.5:1 to 3:1, or 1:1 to 3:1.

[0248] In an embodiment or in combination with any of the embodiments mentioned herein, the pyrolysis oil may have an n-paraffin to i-paraffin weight ratio of at least 0.001:1, or at least 0.1:1, or at least 0.2:1, or at least 0.5:1, or at least 1:1, or at least 2:1, or at least 3:1, or at least 4:1, or at least 5:1, or at least 6:1, or at least 7:1, or at least 8:1, or at least 9:1, or at least 10:1, or at least 15:1, or at least 20:1. Additionally, or alternatively, in an embodiment or in combination with any of the embodiments mentioned herein, the pyrolysis oil may have an n-paraffin to i-paraffin weight ratio of not more than 100:1, 7 or not more than 5:1, or not more than 50:1, or not more than 40:1, or not more than 30:1. In an embodiment or in combination with any of the embodiments mentioned herein, the pyrolysis oil may have an n-paraffin to i-paraffin weight ratio in the range of 1:1 to 100:1, 4:1 to 100:1, or 15:1 to 100:1.

[0249] It should be noted that all of the above-referenced hydrocarbon weight percentages may be determined using gas chromatography-mass spectrometry (GC-MS).

[0250] In an embodiment or in combination with any of the embodiments mentioned herein, the pyrolysis oil may exhibit a density at 15° C. of at least 0.6 g/cm³, or at least 0.65 g/cm³, or at least 0.7 g/cm³. Additionally, or alternatively, in an embodiment or in combination with any of the embodiments mentioned herein, the pyrolysis oil may exhibit a density at 15° C. of not more than 1 g/cm³, or not more than 0.95 g/cm³, or not more than 0.9 g/cm³, or not more than 0.85 g/cm³. In an embodiment or in combination with any of the embodiments mentioned herein, the pyrolysis oil exhibits a density at 15° C. at a range of 0.6 to 1 g/cm³, 0.65 to 0.95 g/cm³, or 0.7 to 0.9 g/cm³.

[0251] In an embodiment or in combination with any of the embodiments mentioned herein, the pyrolysis oil may exhibit an API gravity at 15° C. of at least 28, or at least 29, or at least 30, or at least 31, or at least 32, or at least 33. Additionally, or alternatively, in an embodiment or in combination with any of the embodiments mentioned herein, the pyrolysis oil may exhibit an API gravity at 15° C. of not more than 50, or not more than 49, or not more than 48, or not more than 47, or not more than 46, or not more than 45, or not more than 44. In an embodiment or in combination with any of the embodiments mentioned herein, the pyrolysis oil exhibits an API gravity at 15° C. at a range of 28 to 50, 29 to 58, or 30 to 44.

[0252] In an embodiment or in combination with any of the embodiments mentioned herein, the pyrolysis oil may

have a mid-boiling point of at least 75° C., or at least 80° C., or at least 85° C., or at least 90° C., or at least 95° C., or at least 100° C., or at least 105° C., or at least 110° C., or at least 115° C. The values can be measured according to the procedures described in either according to ASTM D-2887, or in the working examples. A mid-boiling point having the stated value are satisfied if the value is obtained under either method. Additionally, or alternatively, in an embodiment or in combination with any of the embodiments mentioned herein, the pyrolysis oil may have a mid-boiling point of not more than 250° C., or not more than 245° C., or not more than 240° C., or not more than 235° C., or not more than 230° C., or not more than 225° C., or not more than 220° C., or not more than 215° C., or not more than 210° C., or not more than 205° C., or not more than 200° C., or not more than 195° C., or not more than 190° C., or not more than 185° C., or not more than 180° C., or not more than 175° C., or not more than 170° C., or not more than 165° C., or not more than 160° C., or not more than 155° C., or not more than 150° C., or not more than 145° C., or not more than 140° C., or not more than 135° C., or not more than 130° C., or not more than 125° C., or not more than 120° C. The values can be measured according to the procedures described in either according to ASTM D-2887, or in the working examples. A mid-boiling point having the stated value are satisfied if the value is obtained under either method. In an embodiment or in combination with any of the embodiments mentioned herein, the pyrolysis oil may have a mid-boiling point in the range of 75 to 250° C., 90 to 225° C., or 115 to 190° C. As used herein, “mid-boiling point” refers to the median boiling point temperature of the pyrolysis oil when 50 weight percent of the pyrolysis oil boils above the mid-boiling point and 50 weight percent boils below the mid-boiling point.

[0253] In an embodiment or in combination with any of the embodiments mentioned herein, the boiling point range of the pyrolysis oil may be such that not more than 10 percent of the pyrolysis oil has a final boiling point (FBP) of 250° C., 280° C., 290° C., 300° C., or 310° C. To determine the FBP, the procedures described in either according to ASTM D-2887, or in the working examples, can be employed and a FBP having the stated values are satisfied if the value is obtained under either method.

[0254] Turning to the pyrolysis gas, the pyrolysis gas can have a methane content of at least 1, or at least 2, or at least 5, or at least 10, or at least 11, or at least 12, or at least 13, or at least 14, or at least 15, or at least 16, or at least 17, or at least 18, or at least 19, or at least 20 weight percent. Additionally, or alternatively, in an embodiment or in combination with any of the embodiments mentioned herein, the pyrolysis gas can have a methane content of not more than 50, or not more than 45, or not more than 40, or not more than 35, or not more than 30, or not more than 25, in each case weight percent. In an embodiment or in combination with any of the embodiments mentioned herein, the pyrolysis gas can have a methane content in the range of 1 to 50 weight percent, 5 to 50 weight percent, or 15 to 45 weight percent.

[0255] In an embodiment or in combination with any of the embodiments mentioned herein, the pyrolysis gas can have a C₃ hydrocarbon content of at least 1, or at least 2, or at least 3, or at least 4, or at least 5, or at least 6, or at least 7, or at least 8, or at least 9, or at least 10, or at least 15, or at least 20, or at least 25, in each case weight percent.

Additionally, or alternatively, in an embodiment or in combination with any of the embodiments mentioned herein, the pyrolysis gas can have a C₃ hydrocarbon content of not more than 50, or not more than 45, or not more than 40, or not more than 35, or not more than 30, in each case weight percent. In an embodiment or in combination with any of the embodiments mentioned herein, the pyrolysis gas can have a C₃ hydrocarbon content in the range of 1 to 50 weight percent, 5 to 50 weight percent, or 20 to 50 weight percent.

[0256] In an embodiment or in combination with any of the embodiments mentioned herein, the pyrolysis gas can have a C₄ hydrocarbon content of at least 1, or at least 2, or at least 3, or at least 4, or at least 5, or at least 6, or at least 7, or at least 8, or at least 9, or at least 10, or at least 11, or at least 12, or at least 13, or at least 14, or at least 15, or at least 16, or at least 17, or at least 18, or at least 19, or at least 20, in each case weight percent. Additionally, or alternatively, in an embodiment or in combination with any of the embodiments mentioned herein, the pyrolysis gas can have a C₄ hydrocarbon content of not more than 50, or not more than 45, or not more than 40, or not more than 35, or not more than 30, or not more than 25, in each case weight percent. In an embodiment or in combination with any of the embodiments mentioned herein, the pyrolysis gas can have a C₄ hydrocarbon content in the range of 1 to 50 weight percent, 5 to 50 weight percent, or 20 to 50 weight percent.

[0257] In an embodiment or in combination with any of the embodiments mentioned herein, the pyrolysis oils of the present invention may be a recycle content pyrolysis oil composition (r-pyoil).

[0258] Various downstream applications that may utilize the above-disclosed pyrolysis oils and/or the pyrolysis gases are described in greater detail below. In an embodiment or in combination with any of the embodiments mentioned herein, the pyrolysis oil may be subjected to one or more treatment steps prior to being introduced into downstream units, such as a cracking furnace. Examples of suitable treatment steps can include, but are not limited to, separation of less desirable components (e.g., nitrogen-containing compounds, oxygenates, and/or olefins and aromatics), distillation to provide specific pyrolysis oil compositions, and preheating.

[0259] Turning now to FIG. 3, a schematic depiction of a treatment zone for pyrolysis oil according to an embodiment or in combination with any of the embodiments mentioned herein is shown.

[0260] As shown in the treatment zone 220 illustrated in FIG. 3, at least a portion of the r-pyoil 252 made from a recycle waste stream 250 in the pyrolysis system 210 may be passed through a treatment zone 220 such as, for example, a separator, which may separate the r-pyoil into a light pyrolysis oil fraction 254 and a heavy pyrolysis oil fraction 256. The separator 220 employed for such a separation can be of any suitable type, including a single-stage vapor liquid separator or “flash” column, or a multi-stage distillation column. The vessel may or may not include internals and may or may not employ a reflux and/or boil-up stream.

[0261] In an embodiment or in combination with any of the embodiments mentioned herein, the heavy fraction may have a C₄ to C₇ content or a C₈+ content of at least 10, 15, 20, 25, 30, 35, 40, 45, 50, 55, 60, 65, 70, 75, 80, or 85 weight percent. The light fraction may include at least about 10, 15, 20, 25, 30, 35, 40, 45, 50, 55, 60, 65, 70, 75, 80, or 85 percent of C₃ and lighter (C₃₋) or C₇ and lighter (C₇₋)

content. In some embodiments, separator may concentrate desired components into the heavy fraction, such that the heavy fraction may have a C_4 to C_7 content or a C_{8+} content that is at least 10, 15, 20, 25, 30, 35, 40, 45, 50, 55, 60, 65, 70, 75, 80, 85, 90, 95, 100, 105, 110, 115, 120, 125, 130, 135, 140, 145, or 150% greater than the C_4 to C_7 content or the C_{8+} content of the pyrolysis oil withdrawn from the pyrolysis zone. As shown in FIG. 3, at least a portion of the heavy fraction may be sent to the cracking furnace 230 for cracking as or as part of the r-pyoil composition to form an olefin-containing effluent 258, as discussed in further detail below.

[0262] In an embodiment or in combination with any of the embodiments mentioned herein, the pyrolysis oil is hydrotreated in a treatment zone, while, in other embodiments, the pyrolysis oil is not hydrotreated prior to entering downstream units, such as a cracking furnace. In an embodiment or in combination with any of the embodiments mentioned herein, the pyrolysis oil is not pretreated at all before any downstream applications and may be sent directly from the pyrolysis oil source. The temperature of the pyrolysis oil exiting the pre-treatment zone can be in the range of 15 to 55° C., 30 to 55° C., 49 to 40° C., 15 to 50° C., 20 to 45° C., or 25 to 40° C.

[0263] In an embodiment or in combination with any of the embodiments mentioned herein, the r-pyoil may be combined with the non-recycle cracker stream in order to minimize the amount of less desirable compounds present in the combined cracker feed. For example, when the r-pyoil has a concentration of less desirable compounds (such as, for example, impurities like oxygen-containing compounds, aromatics, or others described herein), the r-pyoil may be combined with a cracker feedstock in an amount such that the total concentration of the less desirable compound in the combined stream is at least 40, 50, 55, 60, 65, 70, 75, 80, 85, 90, or 95 percent less than the original content of the compound in the r-pyoil stream (calculated as the difference between the r-pyoil and combined streams, divided by the r-pyoil content, expressed as a percentage). In some cases, the amount of non-recycle cracker feed to combine with the r-pyoil stream may be determined by comparing the measured amount of the one or more less desirable compounds present in the r-pyoil with a target value for the compound or compounds to determine a difference and, then, based on that difference, determining the amount of non-recycle hydrocarbon to add to the r-pyoil stream. The amounts of r-pyoil and non-recycle hydrocarbon are within one or more ranges described herein.

[0264] At least a portion of the r-ethylene is derived directly or indirectly from the cracking of r-pyoil. The process for obtaining r-olefins from cracking (r-pyoil) can be as follows and as described in FIG. 4.

[0265] Turning now to FIG. 4, a block flow diagram illustrating steps associated with the cracking furnace 20 and separation zones 30 of a system for producing an r-composition obtained from cracking r-pyoil. As shown in FIG. 4, a feed stream comprising r-pyoil (the r-pyoil containing feed stream) may be introduced into a cracking furnace 20, alone or in combination with a non-recycle cracker feed stream. A pyrolysis unit producing r-pyoil can be co-located with the production facility. In other embodiments, the r-pyoil can be sourced from a remote pyrolysis unit and transported to the production facility.

[0266] In an embodiment or in combination with any of the embodiments mentioned herein, the r-pyoil containing

feed stream may contain r-pyoil in an amount of at least 1, or at least 5, or at least 10, or at least 15, or at least 20, or at least 25, or at least 30, or at least 35, or at least 40, or at least 45, or at least 50, or at least 55, or at least 60, or at least 65, or at least 70, or at least 75, or at least 80, or at least 85, or at least 90, or at least 95, or at least 97, or at least 98, or at least 99, or at least 100, in each case weight percent and/or not more than 95, or not more than 90, or not more than 85, or not more than 80, or not more than 75, or not more than 70, or not more than 65, or not more than 60, or not more than 55, or not more than 50, or not more than 45, or not more than 40, or not more than 35, or not more than 30, or not more than 25, or not more than 20, in each case weight percent, based on the total weight of the r-pyoil containing feed stream.

[0267] In an embodiment or in combination with any of the embodiments mentioned herein, at least 1, or at least 5, or at least 10, or at least 15, or at least 20, or at least 25, or at least 30, or at least 35, or at least 40, or at least 45, or at least 50, or at least 55, or at least 60, or at least 65, or at least 70, or at least 75, or at least 80, or at least 85, or at least 90 or at least 97, or at least 98, or at least 99, or 100, in each case weight percent and/or not more than 95, or not more than 90, or not more than 85, or not more than 80, or not more than 75, or not more than 70, or not more than 65, or not more than 60, or not more than 55, or not more than 50, or not more than 45, or not more than 40, or not more than 35, or not more than 30, or not more than 25, or not more than 20, or not more than 15 or not more than 10, in each case weight percent of the r-pyoil is obtained from the pyrolysis of a waste stream. In an embodiment or in combination with any of the embodiments mentioned herein, at least a portion of the r-pyoil is obtained from pyrolysis of a feedstock comprising plastic waste. Desirably, at least 90, or at least 95, or at least 97, or at least 98, or at least 99, or at least 100, in each case wt. %, of the r-pyoil is obtained from pyrolysis of a feedstock comprising plastic waste, or a feedstock comprising at least 50 wt. % plastic waste, or a feedstock comprising at least 80 wt. % plastic waste, or a feedstock comprising at least 90 wt. % plastic waste, or a feedstock comprising at least 95 wt. % plastic waste.

[0268] In an embodiment or in combination with any of the embodiments mentioned herein, the r-pyoil can have any one or combination of the compositional characteristics described above with respect to pyrolysis oil.

[0269] In an embodiment or in combination with any of the embodiments mentioned herein, the r-pyoil may comprise at least 55, or at least 60, or at least 65, or at least 70, or at least 75, or at least 80, or at least 85, or at least 90, or at least 95, in each case weight percent of C_4 - C_{30} hydrocarbons, and as used herein, hydrocarbons include aliphatic, cycloaliphatic, aromatic, and heterocyclic compounds. In an embodiment or in combination with any of the embodiments mentioned herein, the r-pyoil can predominantly comprise C_5 - C_{25} , C_5 - C_{22} , or C_5 - C_{20} hydrocarbons, or may comprise at least 55, 60, 65, 70, 75, 80, 85, 90, or 95 weight percent of C_5 - C_{25} , C_5 - C_{22} , or C_5 - C_{20} hydrocarbons.

[0270] In an embodiment or in combination with any embodiment mentioned herein or in combination with any of the mentioned embodiments, the r-pyoil composition can comprise C_4 - C_{12} aliphatic compounds (branched or unbranched alkanes and alkenes including diolefins, and alicyclics) and C_{13} - C_{22} aliphatic compounds in a weight ratio of more than 1:1, or at least 1.25:1, or at least 1.5:1, or

at least 2:1, or at least 2.5:1, or at least 3:1, or at least 4:1, or at least 5:1, or at least 6:1, or at least 7:1, 10:1, 20:1, or at least 40:1, each by weight and based on the weight of the r-pyoil.

[0271] In an embodiment or in combination with any embodiment mentioned herein or in combination with any of the mentioned embodiments, the r-pyoil composition can comprise C₁₃-C₂₂ aliphatic compounds (branched or unbranched alkanes and alkenes including diolefins, and alicyclics) and C₄-C₁₂ aliphatic compounds in a weight ratio of more than 1:1, or at least 1.25:1, or at least 1.5:1, or at least 2:1, or at least 2.5:1, or at least 3:1, or at least 4:1, or at least 5:1, or at least 6:1, or at least 7:1, 10:1, 20:1, or at least 40:1, each by weight and based on the weight of the r-pyoil.

[0272] In an embodiment, the two aliphatic hydrocarbons (branched or unbranched alkanes and alkenes, and alicyclics) having the highest concentration in the r-pyoil are in a range of C₅-C₁₈, or C₅-C₁₆, or C₅-C₁₄, or C₅-C₁₀, or C₅-C₈, inclusive.

[0273] The r-pyoil includes one or more of paraffins, naphthenes or cyclic aliphatic hydrocarbons, aromatics, aromatic containing compounds, olefins, oxygenated compounds and polymers, heteroatom compounds or polymers, and other compounds or polymers.

[0274] For example, in an embodiment or in combination with any of the embodiments mentioned herein, the r-pyoil may comprise at least 5, or at least 10, or at least 15, or at least 20, or at least 25, or at least 30, or at least 35, or at least 40, or at least 45, or at least 50, or at least 55, or at least 60, or at least 65, or at least 70, or at least 75, or at least 80, or at least 85, or at least 90, or at least 95, in each case weight percent and/or not more than 99, or not more than 97, or not more than 95, or not more than 93, or not more than 90, or not more than 87, or not more than 85, or not more than 83, or not more than 80, or not more than 78, or not more than 75, or not more than 70, or not more than 65, or not more than 60, or not more than 55, or not more than 50, or not more than 45, or not more than 40, or not more than 35, or not more than 30, or not more than 25, or not more than 20, or not more than 15, in each case weight percent of paraffins (or linear or branched alkanes), based on the total weight of the r-pyoil. In an embodiment or in combination with any of the embodiments mentioned herein, the pyrolysis oil may have a paraffin content in the range of 25 to 90, 35 to 90, or 40 to 80, or 40-70, or 40-65 weight percent, or 5-50, or 5 to 40, or 5 to 35, or 10- to 35, or 10 to 30, or 5 to 25, or 5 to 20, in each case as wt. % based on the weight of the r-pyoil composition.

[0275] In an embodiment or in combination with any of the embodiments mentioned herein, the r-pyoil can include naphthenes or cyclic aliphatic hydrocarbons in amount of zero, or at least 1, or at least 2, or at least 5, or at least 8, or at least 10, or at least 15, or at least 20, in each case weight percent and/or not more than 50, or not more than 45, or not more than 40, or not more than 35, or not more than 30, or not more than 25, or not more than 20, or not more than 15, or not more than 10, or not more than 5, or not more than 2, or not more than 1, or not more than 0.5, or no detectable amount, in each case weight percent. In an embodiment or in combination with any of the embodiments mentioned herein, the r-pyoil may have a naphthene content of not more than 5, or not more than 2, or not more than 1 wt. %, or no detectable amount, or naphthenes. Examples of ranges for

the amount of naphthenes (or cyclic aliphatic hydrocarbons) contained in the r-pyoil is from 0-35, or 0-30, or 0-25, or 2-20, or 2-15, or 2-10, or 1-10, in each case as wt. % based on the weight of the r-pyoil composition.

[0276] In an embodiment or in combination with any of the embodiments mentioned herein, the r-pyoil may have a paraffin to olefin weight ratio of at least 0.2:1, or at least 0.3:1, or at least 0.4:1, or at least 0.5:1, or at least 0.6:1, or at least 0.7:1, or at least 0.8:1, or at least 0.9:1, or at least 1:1. Additionally, or alternatively, in an embodiment or in combination with any of the embodiments mentioned herein, the r-pyoil may have a paraffin to olefin weight ratio not more than 3:1, or not more than 2.5:1, or not more than 2:1, or not more than 1.5:1, or not more than 1.4:1, or not more than 1.3:1. In an embodiment or in combination with any of the embodiments mentioned herein, the r-pyoil may have a paraffin to olefin weight ratio in the range of 0.2:1 to 5:1, or 1:1 to 4.5:1, or 1.5:1 to 5:1, or 1.5:1:4.5:1, or 0.2:1 to 4:1, or 0.2:1 to 3:1, 0.5:1 to 3:1, or 1:1 to 3:1.

[0277] In an embodiment or in combination with any of the embodiments mentioned herein, the r-pyoil may have an n-paraffin to i-paraffin weight ratio of at least 0.001:1, or at least 0.1:1, or at least 0.2:1, or at least 0.5:1, or at least 1:1, or at least 2:1, or at least 3:1, or at least 4:1, or at least 5:1, or at least 6:1, or at least 7:1, or at least 8:1, or at least 9:1, or at least 10:1, or at least 15:1, or at least 20:1. Additionally, or alternatively, in an embodiment or in combination with any of the embodiments mentioned herein, the r-pyoil may have an n-paraffin to i-paraffin weight ratio of not more than 100:1, or not more than 50:1, or not more than 40:1, or not more than 30:1. In an embodiment or in combination with any of the embodiments mentioned herein, the r-pyoil may have an n-paraffin to i-paraffin weight ratio in the range of 1:1 to 100:1, 4:1 to 100:1, or 15:1 to 100:1.

[0278] In an embodiment, the r-pyoil comprises not more than 30, or not more than 25, or not more than 20, or not more than 15, or not more than 10, or not more than 8, or not more than 5, or not more than 2, or not more than 1, in each case weight percent of aromatics, based on the total weight of the r-pyoil. As used herein, the term "aromatics" refers to the total amount (in weight) of benzene, toluene, xylene, and styrene. The r-pyoil may include at least 1, or at least 2, or at least 5, or at least 8, or at least 10, in each case weight percent of aromatics, based on the total weight of the r-pyoil.

[0279] In an embodiment or in combination with any of the embodiments mentioned herein, the r-pyoil can include aromatic containing compounds in an amount of not more than 30, or not more than 25, or not more than 20, or not more than 15, or not more than 10, or not more than 8, or not more than 5, or not more than 2, or not more than 1, in each case weight, or not detectable, based on the total weight of the r-pyoil. Aromatic containing compounds includes the above-mentioned aromatics and any compounds containing an aromatic moiety, such as terephthalate residues and fused ring aromatics such as the naphthalenes and tetrahydronaphthalene.

[0280] In an embodiment or in combination with any of the embodiments mentioned herein, the r-pyoil can include olefins in amount of at least 1, or at least 2, or at least 5, or at least 8, or at least 10, or at least 15, or at least 20, or at least 30, or at least 40, or at least 45, or at least 50, or at least 55, or at least 60, or at least or at least 65, in each case weight percent olefins and/or not more than 85, or not more than 80, or not more than 75, or not more than 70, or not more than

65, or not more than 60, or not more than 55, or not more than 50, or not more than 45, or not more than 40, or not more than 35, or not more than 30, or not more than 25, or not more than 20, or not more than 15, or not more than 10, in each case weight percent, based on the weight of a r-pyoil. Olefins include mono- and di-olefins. Examples of suitable ranges include olefins present in an amount ranging from 5 to 45, or 10-35, or 15 to 30, or 40-85, or 45-85, or 50-85, or 55-85, or 60-85, or 65-85, or 40-80, or 45-80, or 50-80, or 55-80, or 60-80, or 65-80, or 45-80, or 50-80, or 55-80, or 60-80, or 65-80, or 40-75, or 45-75, or 50-75, or 55-75, or 60-75, or 65-75, or 40-70, or 45-70, or 50-70, or 55-70, or 60-70, or 65-70, or 40-65, or 45-65, or 50-65, or 55-65, in each case as wt. % based on the weight of the r-pyoil.

[0281] In an embodiment or in combination with any of the embodiments mentioned herein, the r-pyoil can include oxygenated compounds or polymers in amount of zero or at least 0.01, or at least 0.1, or at least 1, or at least 2, or at least 5, in each case weight percent and/or not more than 20, or not more than 15, or not more than 10, or not more than 8, or not more than 6, or not more than 5, or not more than 3, or not more than 2, in each case weight percent oxygenated compounds or polymers, based on the weight of a r-pyoil. Oxygenated compounds and polymers are those containing an oxygen atom. Examples of suitable ranges include oxygenated compounds present in an amount ranging from 0-20, or 0-15, or 0-10, or 0.01-10, or 1-10, or 2-10, or 0.01-8, or 0.1-6, or 1-6, or 0.01-5, in each case as wt. % based on the weight of the r-pyoil.

[0282] In an embodiment or in combination with any embodiment mentioned herein or in combination with any of the mentioned embodiments, the amount of oxygen atoms in the r-pyoil can be not more than 10, or not more than 8, or not more than 5, or not more than 4, or not more than 3, or not more than 2.75, or not more than 2.5, or not more than 2.25, or not more than 2, or not more than 1.75, or not more than 1.5, or not more than 1.25, or not more than 1, or not more than 0.75, or not more than 0.5, or not more than 0.25, or not more than 0.1, or not more than 0.05, in each case wt. %, based on the weight of the r-pyoil. Examples of the amount of oxygen in the r-pyoil can be from 0-8, or 0-5, or 0-3, or 0-2.5 or 0-2, or 0.001-5, or 0.001-4, or 0.001-3, or 0.001-2.75, or 0.001-2.5, or 0.001-2, or 0.001-1.5, or 0.001-1, or 0.001-0.5, or 0.001-0.1, in each case as wt. % based on the weight of the r-pyoil.

[0283] In an embodiment or in combination with any of the embodiments mentioned herein, the r-pyoil can include heteroatom compounds or polymers in amount of at least 1, or at least 2, or at least 5, or at least 8, or at least 10, or at least 15, or at least 20, in each case weight percent and/or not more than 25, or not more than 20, or not more than 15, or not more than 10, or not more than 8, or not more than 6, or not more than 5, or not more than 3, or not more than 2, in each case weight percent, based on the weight of a r-pyoil. A heterocompound or polymer is defined in this paragraph as any compound or polymer containing nitrogen, sulfur, or phosphorus. Any other atom is not regarded as a heteroatom for purposes of determining the quantity of heteroatoms, heterocompounds, or heteropolymers present in the r-pyoil. The r-pyoil can contain heteroatoms present in an amount of not more than 5, or not more than 4, or not more than 3, or not more than 2.75, or not more than 2.5, or not more than 2.25, or not more than 2, or not more than 1.75, or not more than 1.5, or not more than 1.25, or not more than 1, or not

more than 0.75, or not more than 0.5, or not more than 0.25, or not more than 0.1, or not more than 0.075, or not more than 0.05, or not more than 0.03, or not more than 0.02, or not more than 0.01, or not more than 0.008, or not more than 0.006, or not more than 0.005, or not more than 0.003, or not more than 0.002, in each case wt. %, based on the weight of the r-pyoil.

[0284] In an embodiment or in combination with any embodiment mentioned herein or in combination with any of the embodiments mentioned herein, the solubility of water in the r-pyoil at 1 atm and 25° C. is less than 2 wt. %, water, or not more than 1.5, or not more than 1, or not more than 0.5, or not more than 0.1, or not more than 0.075, or not more than 0.05, or not more than 0.025, or not more than 0.01, or not more than 0.005, in each case wt. % water based on the weight of the r-pyoil. Desirably, the solubility of water in the r-pyoil is not more than 0.1 wt. % based on the weight of the r-pyoil. In an embodiment or in combination with any embodiment mentioned herein or in combination with any of the embodiments mentioned herein, the r-pyoil contains not more than 2 wt. %, water, or not more than 1.5, or not more than 1, or not more than 0.5, desirably or not more than 0.1, or not more than 0.075, or not more than 0.05, or not more than 0.025, or not more than 0.01, or not more than 0.005, in each case wt. % water based on the weight of the r-pyoil.

[0285] In an embodiment or in combination with any embodiment mentioned herein or in combination with any of the embodiments mentioned herein, the solids content in the r-pyoil does not exceed 1, or is not more than 0.75, or not more than 0.5, or not more than 0.25, or not more than 0.2, or not more than 0.15, or not more than 0.1, or not more than 0.05, or not more than 0.025, or not more than 0.01, or not more than 0.005, or does not exceed 0.001, in each case wt. % solids based on the weight of the r-pyoil.

[0286] In an embodiment or in combination with any embodiment mentioned herein or in combination with any of the embodiments mentioned herein the sulfur content of the r-pyoil does not exceed 2.5 wt. %, or is not more than 2, or not more than 1.75, or not more than 1.5, or not more than 1.25, or not more than 1, or not more than 0.75, or not more than 0.5, or not more than 0.25, or not more than 0.1, or not more than 0.05, desirably or not more than 0.03, or not more than 0.02, or not more than 0.01, or not more than 0.008, or not more than 0.006, or not more than 0.004, or not more than 0.002, or is not more than 0.001, in each case wt. % based on the weight of the r-pyoil.

[0287] In an embodiment or in combination with any embodiment mentioned herein or in combination with any of the embodiments mentioned herein, the r-pyoil can have the following compositional content:

[0288] carbon atom content of at least 75 wt. %, or at least or at least 77, or at least 80, or at least 82, or at least 85, in each case wt. %, and/or up to 90, or up to 88, or not more than 86, or not more than 85, or not more than 83, or not more than 82, or not more than 80, or not more than 77, or not more than 75, or not more than 73, or not more than 70, or not more than 68, or not more than 65, or not more than 63, or up to 60, in each case wt. %, desirably at least 82% and up to 93%, and/or

[0289] hydrogen atom content of at least 10 wt. %, or at least 13, or at least 14, or at least 15, or at least 16, or at least 17, or at least 18, or not more than 19, or not

more than 18, or not more than 17, or not more than 16, or not more than 15, or not more than 14, or not more than 13, or up to 11, in each case wt. %.

[0290] an oxygen atom content not to exceed 10, or not more than 8, or not more than 5, or not more than 4, or not more than 3, or not more than 2.75, or not more than 2.5, or not more than 2.25, or not more than 2, or not more than 1.75, or not more than 1.5, or not more than 1.25, or not more than 1, or not more than 0.75, or not more than 0.5, or not more than 0.25, or not more than 0.1, or not more than 0.05, in each case wt. %.

[0291] in each case based on the weight of the r-pyoil.

[0292] In an embodiment or in combination with any embodiment mentioned herein or in combination with any of the mentioned embodiments, the amount of hydrogen atoms in the r-pyoil can be in a range of from 10-20, or 10-18, or 11-17, or 12-16 or 13-16, or 13-15, or 12-15, in each case as wt. % based on the weight of the r-pyoil.

[0293] In an embodiment or in combination with any embodiment mentioned herein or in combination with any of the embodiments mentioned herein, the metal content of the r-pyoil is desirably low, for example, not more than 2 wt. %, or not more than 1, or not more than 0.75, or not more than 0.5, or not more than 0.25, or not more than 0.2, or not more than 0.15, or not more than 0.1, or not more than 0.05, in each case wt. % based on the weight of the r-pyoil.

[0294] In an embodiment or in combination with any embodiment mentioned herein or in combination with any of the embodiments mentioned herein, the alkali metal and alkaline earth metal or mineral content of the r-pyoil is desirably low, for example, not more than 2 wt. %, or not more than 1, or not more than 0.75, or not more than 0.5, or not more than 0.25, or not more than 0.2, or not more than 0.15, or not more than 0.1, or not more than 0.05, in each case wt. % based on the weight of the r-pyoil.

[0295] In an embodiment or in combination with any embodiment mentioned herein or in combination with any of the embodiments mentioned herein, the weight ratio of paraffin to naphthene in the r-pyoil can be at least 1:1, or at least 1.5:1, or at least 2:1, or at least 2.2:1, or at least 2.5:1, or at least 2.7:1, or at least 3:1, or at least 3.3:1, or at least 3.5:1, or at least 3.75:1, or at least 4:1, or at least 4.25:1, or at least 4.5:1, or at least 4.75:1, or at least 5:1, or at least 6:1, or at least 7:1, or at least 8:1, or at least 9:1, or at least 10:1, or at least 13:1, or at least 15:1, or at least 17:1, based on the weight of the r-pyoil.

[0296] In an embodiment or in combination with any embodiment mentioned herein or in combination with any of the embodiments mentioned herein, the weight ratio of paraffin and naphthene combined to aromatics can be at least 1:1, or at least 1.5:1, or at least 2:1, or at least 2.5:1, or at least 2.7:1, or at least 3:1, or at least 3.3:1, or at least 3.5:1, or at least 3.75:1, or at least 4:1, or at least 4.5:1, or at least 5:1, or at least 7:1, or at least 10:1, or at least 15:1, or at least 20:1, or at least 25:1, or at least 30:1, or at least 35:1, or at least 40:1, based on the weight of the r-pyoil. In an embodiment or in combination with any embodiment mentioned herein or in combination with any of the mentioned embodiments, the ratio of paraffin and naphthene combined to aromatics in the r-pyoil can be in a range of from 50:1-1:1, or 40:1-1:1, or 30:1-1:1, or 20:1-1:1, or 30:1-3:1, or 20:1-1:1, or 20:1-5:1, or 50:1-5:1, or 30:1-5:1, or 1:1-7:1, or 1:1-5:1, 1:1-4:1, or 1:1-3:1.

[0297] In an embodiment or in combination with any of the embodiments mentioned herein, the r-pyoil may have a boiling point curve defined by one or more of its 10%, its 50%, and its 90% boiling points, as defined below. As used herein, "boiling point" refers to the boiling point of a composition as determined by ASTM D2887 or according to the procedure described in the working examples. A boiling point having the stated values are satisfied if the value is obtained under either method. Additionally, as used herein, an "x % boiling point," refers to a boiling point at which x percent by weight of the composition boils per either of these methods.

[0298] As used throughout, an x % boiling at a stated temperature means at least x % of the composition boils at the stated temperature. In an embodiment or in combination with any of the embodiments mentioned herein, the 90% boiling point of the cracker feed stream or composition can be not more than 350, or not more than 325, or not more than 300, or not more than 295, or not more than 290, or not more than 285, or not more than 280, or not more than 275, or not more than 270, or not more than 265, or not more than 260, or not more than 255, or not more than 250, or not more than 245, or not more than 240, or not more than 235, or not more than 230, or not more than 225, or not more than 220, or not more than 215, not more than 200, not more than 190, not more than 180, not more than 170, not more than 160, not more than 150, or not more than 140, in each case ° C. and/or at least 200, or at least 205, or at least 210, or at least 215, or at least 220, or at least 225, or at least 230, in each case ° C. and/or not more than 25, 20, 15, 10, 5, or 2 weight percent of the r-pyoil may have a boiling point of 300° C. or higher.

[0299] Referring again to FIG. 3, the r-pyoil may be introduced into a cracking furnace or coil or tube alone (e.g., in a stream comprising at least 85, or at least 90, or at least 95, or at least 99, or 100, in each case wt. % percent pyrolysis oil based on the weight of the cracker feed stream), or combined with one or more non-recycle cracker feed streams. When introduced into a cracker furnace, coil, or tube with a non-recycle cracker feed stream, the r-pyoil may be present in an amount of at least 1, or at least 2, or at least 5, or at least 8, or at least 10, or at least 12, or at least 15, or at least 20, or at least 25, or at least 30, in each case wt. % and/or not more than 40, or not more than 35, or not more than 30, or not more than 25, or not more than 20, or not more than 15, or not more than 10, or not more than 8, or not more than 5, or not more than 2, in each case weight percent based on the total weight of the combined stream. Thus, the non-recycle cracker feed stream or composition may be present in the combined stream in an amount of at least 20, or at least 25, or at least 30, or at least 35, or at least 40, or at least 45, or at least 50, or at least 55, or at least 60, or at least 65, or at least 70, or at least 75, or at least 80, or at least 85, or at least 90, in each case weight percent and/or not more than 99, or not more than 95, or not more than 90, or not more than 85, or not more than 80, or not more than 75, or not more than 70, or not more than 65, or not more than 60, or not more than 55, or not more than 50, or not more than 45, or not more than 40, in each case weight percent based on the total weight of the combined stream. Unless otherwise noted herein, the properties of the cracker feed stream as described below apply either to the non-recycle cracker feed stream prior to (or absent) combination with the

stream comprising r-pyoil, as well as to a combined cracker stream including both a non-recycle cracker feed and a r-pyoil feed.

[0300] In an embodiment or in combination with any of the embodiments mentioned herein, the cracker feed stream may comprise a predominantly C₂-C₄ hydrocarbon containing composition, or a predominantly C₅-C₂₂ hydrocarbon containing composition. As used herein, the term “predominantly C₂-C₄ hydrocarbon,” refers to a stream or composition containing at least 50 weight percent of C₂-C₄ hydrocarbon components. Examples of specific types of C₂-C₄ hydrocarbon streams or compositions include propane, ethane, butane, and LPG. In an embodiment or in combination with any of the embodiments mentioned herein, the cracker feed may comprise at least 50, or at least 55, or at least 60, or at least 65, or at least 70, or at least 75, or at least 80, or at least 85, or at least 90, or at least 95, in each case wt. % based on the total weight of the feed, and/or not more than 100, or not more than 99, or not more than 95, or not more than 92, or not more than 90, or not more than 85, or not more than 80, or not more than 75, or not more than 70, or not more than 65, or not more than 60, in each case weight percent C₂-C₄ hydrocarbons or linear alkanes, based on the total weight of the feed. The cracker feed can comprise predominantly propane, predominantly ethane, predominantly butane, or a combination of two or more of these components. These components may be non-recycle components. The cracker feed can comprise predominantly propane, or at least 50 mole % propane, or at least 80 mole % propane, or at least 90 mole % propane, or at least 93 mole % propane, or at least 95 mole % propane (inclusive of any recycle streams combined with virgin feed). The cracker feed can comprise HD5 quality propane as a virgin or fresh feed. The cracker can comprise at more than 50 mole % ethane, or at least 80 mole % ethane, or at least 90 mole % ethane, or at least 95 mole % ethane. These components may be non-recycle components.

[0301] In an embodiment or in combination with any of the embodiments mentioned herein, the cracker feed stream may comprise a predominantly C₅-C₂₂ hydrocarbon containing composition. As used herein, “predominantly C₅-C₂₂ hydrocarbon” refers to a stream or composition comprising at least 50 weight percent of C₅-C₂₂ hydrocarbon components. Examples include gasoline, naphtha, middle distillates, diesel, kerosene. In an embodiment or in combination with any of the embodiments mentioned herein, the cracker feed stream or composition may comprise at least 20, or at least 25, or at least 30, or at least 35, or at least 40, or at least 45, or at least 50, or at least 55, or at least 60, or at least 65, or at least 70, or at least 75, or at least 80, or at least 85, or at least 90, or at least 95, in each case wt. % and/or not more than 100, or not more than 99, or not more than 95, or not more than 92, or not more than 90, or not more than 85, or not more than 80, or not more than 75, or not more than 70, or not more than 65, or not more than 60, in each case weight percent C₅-C₂₂, or C₅-C₂₀ hydrocarbons, based on the total weight of the stream or composition. In an embodiment or in combination with any of the embodiments mentioned herein, the cracker feed may have a C₁₅ and heavier (C₁₅+) content of at least 0.5, or at least 1, or at least 2, or at least 5, in each case weight percent and/or not more than 40, or not more than 35, or not more than 30, or not more than 25, or not more than 20, or not more than 18, or not more than 15, or not more than 12, or not more than 10, or not more

than 5, or not more than 3, in each case weight percent, based on the total weight of the feed.

[0302] The cracker feed may have a boiling point curve defined by one or more of its 10%, its 50%, and its 90% boiling points, the boiling point being obtained by the methods described above. Additionally, as used herein, an “x % boiling point,” refers to a boiling point at which x percent by weight of the composition boils per the methods described above. In an embodiment or in combination with any of the embodiments mentioned herein, the 90% boiling point of the cracker feed stream or composition can be not more than 360, or not more than 355, or not more than 350, or not more than 345, or not more than 340, or not more than 335, or not more than 330, or not more than 325, or not more than 320, or not more than 315, or not more than 300, or not more than 295, or not more than 290, or not more than 285, or not more than 280, or not more than 275, or not more than 270, or not more than 265, or not more than 260, or not more than 255, or not more than 250, or not more than 245, or not more than 240, or not more than 235, or not more than 230, or not more than 225, or not more than 220, or not more than 215, in each case ° C. and/or at least 200, or at least 205, or at least 210, or at least 215, or at least 220, or at least 225, or at least 230, in each case ° C.

[0303] In an embodiment or in combination with any of the embodiments mentioned herein, the 10% boiling point of the cracker feed stream or composition can be at least 40, at least 50, at least 60, at least 70, at least 80, at least 90, at least 100, at least 110, at least 120, at least 130, at least 140, at least 150, or at least 155, in each case ° C. and/or not more than 250, not more than 240, not more than 230, not more than 220, not more than 210, not more than 200, not more than 190, not more than 180, or not more than 170 in each case ° C.

[0304] In an embodiment or in combination with any of the embodiments mentioned herein, the 50% boiling point of the cracker feed stream or composition can be at least 60, at least 65, at least 70, at least 75, at least 80, at least 85, at least 90, at least 95, at least 100, at least 110, at least 120, at least 130, at least 140, at least 150, at least 160, at least 170, at least 180, at least 190, at least 200, at least 210, at least 220, or at least 230, in each case ° C. and/or not more than 300, not more than 290, not more than 280, not more than 270, not more than 260, not more than 250, not more than 240, not more than 230, not more than 220, not more than 210, not more than 200, not more than 190, not more than 180, not more than 170, not more than 160, not more than 150, or not more than 145° C. The 50% boiling point of the cracker feed stream or composition can be in the range of 65 to 160, 70 to 150, 80 to 145, 85 to 140, 85 to 230, 90 to 220, 95 to 200, 100 to 190, 110 to 180, 200 to 300, 210 to 290, 220 to 280, 230 to 270, in each case in ° C.

[0305] In an embodiment or in combination with any of the embodiments mentioned herein, the 90% boiling point of the cracker feedstock or stream or composition can be at least 350° C., the 10% boiling point can be at least 60° C.; and the 50% boiling point can be in the range of from 95° C. to 200° C. In an embodiment or in combination with any of the embodiments mentioned herein, the 90% boiling point of the cracker feedstock or stream or composition can be at least 150° C., the 10% boiling point can be at least 60° C., and the 50% boiling point can be in the range of from 80 to 145° C. In an embodiment or in combination with any of the embodiments mentioned herein, the cracker feedstock or

stream has a 90% boiling point of at least 350° C., a 10% boiling point of at least 150° C., and a 50% boiling point in the range of from 220 to 280° C.

[0306] In an embodiment or in combination with any embodiment mentioned herein or in combination with any of the embodiments mentioned herein, the r-pyoil is cracked in a gas furnace. A gas furnace is a furnace having at least one coil which receives (or operated to receive), at the inlet of the coil at the entrance to the convection zone, a predominately vapor-phase feed (more than 50% of the weight of the feed is vapor) (“gas coil”). In an embodiment or in combination with any embodiment mentioned herein or in combination with any of the mentioned embodiments, the gas coil can receive a predominately C₂-C₄ feedstock, or a predominately a C₂-C₃ feedstock to the inlet of the coil in the convection section, or alternatively, having at least one coil receiving more than 50 wt. % ethane and/or more than 50% propane and/or more than 50% LPG, or in any one of these cases at least 60 wt. %, or at least 70 wt. %, or at least 80 wt. %, based on the weight of the cracker feed to the coil, or alternatively based on the weight of the cracker feed to the convection zone. The gas furnace may have more than one gas coil. In an embodiment or in combination with any embodiment mentioned herein or in combination with any of the mentioned embodiments, at least 25% of the coils, or at least 50% of the coils, or at least 60% of the coils, or all the coils in the convection zone or within a convection box of the furnace are gas coils. In an embodiment or in combination with any embodiment mentioned herein or in combination with any of the mentioned embodiments, the gas coil receives, at the inlet of the coil at the entrance to the convection zone, a vapor-phase feed in which at least 60 wt. %, or at least 70 wt. %, or at least 80 wt. %, or at least 90 wt. %, or at least 95 wt. %, or at least 97 wt. %, or at least 98 wt. %, or at least 99 wt. %, or at least 99.5 wt. %, or at least 99.9 wt. % of feed is vapor.

[0307] In an embodiment or in combination with any embodiment mentioned herein or in combination with any of the mentioned embodiments, the r-pyoil is cracked in a split furnace. A split furnace is a type of gas furnace. A split furnace contains at least one gas coil and at least one liquid coil within the same furnace, or within the same convection zone, or within the same convection box. A liquid coil is a coil which receives, at the inlet of coil at the entrance to the convection zone, a predominately liquid phase feed (more than 50% of the weight of the feed is liquid) (“liquid coil”). In an embodiment or in combination with any embodiment mentioned herein or in combination with any of the mentioned embodiments, the liquid coil can receive a predominately C₅+ feedstock to the inlet of the coil at the entrance of the convection section (“liquid coil”). In an embodiment or in combination with any embodiment mentioned herein or in combination with any of the mentioned embodiments, the liquid coil can receive a predominately C₆-C₂₂ feedstock, or a predominately a C₇-C₁₆ feedstock to the inlet of the coil in the convection section, or alternatively, having at least one coil receiving more than 50 wt. % naphtha, and/or more than 50% natural gasoline, and/or more than 50% diesel, and/or more than JP-4, and/or more than 50% Stoddard Solvent, and/or more than 50% kerosene, and/or more than 50% fresh creosote, and/or more than 50% JP-8 or Jet-A, and/or more than 50% heating oil, and/or more than 50% heavy fuel oil, and/or more than 50% bunker C, and/or more than 50% lubricating oil, or in any one of these cases at least 60 wt. %,

or at least 70 wt. %, or at least 80 wt. %, or at least 90 wt. %, or at least 95 wt. %, or at least 98 wt. %, or at least 99 wt. %, based on the weight of the cracker feed to the liquid coil, or alternatively based on the weight of the cracker feed to the convection zone. In an embodiment or in combination with any embodiment mentioned herein or in combination with any of the mentioned embodiments, at least one coil and not more than 75% of the coils, or not more than 50% of the coils, or not more than at least 40% of the coils in the convection zone or within a convection box of the furnace are liquid coils. In an embodiment or in combination with any embodiment mentioned herein or in combination with any of the mentioned embodiments, the liquid coil receives, at the inlet of the coil at the entrance to the convection zone, a liquid-phase feed in which at least 60 wt. %, or at least 70 wt. %, or at least 80 wt. %, or at least 90 wt. %, or at least 95 wt. %, or at least 97 wt. %, or at least 98 wt. %, or at least 99 wt. %, or at least 99.5 wt. %, or at least 99.9 wt. % of feed is liquid.

[0308] In an embodiment or in combination with any embodiment mentioned herein or in combination with any of the mentioned embodiments, the r-pyoil is cracked in a thermal gas cracker.

[0309] In an embodiment or in combination with any embodiment mentioned herein or in combination with any of the mentioned embodiments, the r-pyoil is cracked in a thermal steam gas cracker in the presence of steam. Steam cracking refers to the high-temperature cracking (decomposition) of hydrocarbons in the presence of steam.

[0310] In an embodiment or in combination with any embodiment mentioned herein or in combination with any of the mentioned embodiments, the r-composition is derived directly or indirectly from cracking r-pyoil in a gas furnace. The coils in the gas furnace can consist entirely of gas coils or the gas furnace can be a split furnace.

[0311] When the r-pyoil containing feed stream is combined with the non-recycle cracker feed, such a combination may occur upstream of, or within, the cracking furnace or within a single coil or tube. Alternatively, the r-pyoil containing feed stream and non-recycle cracker feed may be introduced separately into the furnace, and may pass through a portion, or all, of the furnace simultaneously while being isolated from one another by feeding into separate tubes within the same furnace (e.g., a split furnace). Ways of introducing the r-pyoil containing feed stream and the non-recycle cracker feed into the cracking furnace according to an embodiment or in combination with any of the embodiments mentioned herein are described in further detail below.

[0312] Turning now to FIG. 5, a schematic diagram of a cracker furnace suitable for use in an embodiment or in combination with any of the embodiments mentioned herein is shown.

[0313] In one embodiment or in combination of any of the mentioned embodiments, there is provided a method for making one or more olefins including:

[0314] (a) feeding a first cracker feed comprising a recycle content pyrolysis oil composition (r-pyoil) to a cracker furnace;

[0315] (b) feeding a second cracker feed into said cracker furnace, wherein said second cracker feed comprises none of said r-pyoil or less of said r-pyoil, by weight, than said first cracker feed stream; and

[0316] (c) cracking said first and said second cracker feeds in respective first and second tubes to form an olefin-containing effluent stream.

[0317] The r-pyoil can be combined with a cracker stream to make a combined cracker stream, or as noted above, a first cracker stream. The first cracker stream can be 100% r-pyoil or a combination of a non-recycle cracker stream and r-pyoil. The feeding of step (a) and/or step (b) can be performed upstream of the convection zone or within the convection zone. The r-pyoil can be combined with a non-recycle cracker stream to form a combined or first cracker stream and fed to the inlet of a convection zone, or alternatively the r-pyoil can be separately fed to the inlet of a coil or distributor along with a non-recycle cracker stream to form a first cracker stream at the inlet of the convection zone, or the r-pyoil can be fed downstream of the inlet of the convection zone into a tube containing non-recycle cracker feed, but before a crossover, to make a first cracker stream or combined cracker stream in a tube or coil. Any of these methods includes feeding the first cracker stream to the furnace.

[0318] The amount of r-pyoil added to the non-recycle cracker stream to make the first cracker stream or combined cracker stream can be as described above; e.g. in an amount of at least 1, 5, 10, 15, 20, 25, 30, 35, 40, 45, 50, 55, 60, 65, 70, 75, 80, 85, 90, or 95, in each case weight percent and/or not more than 95, 90, 85, 80, 75, 70, 65, 60, 55, 50, 45, 40, 35, 30, 25, 20, 15, or 1, in each case weight percent, based on the total weight of the first cracker feed or combined cracker feed (either as introduced into the tube or within the tube as noted above). Further examples include 5-50, 5-40, 5-35, 5-30, 5-25, 5-20, or 5-15 wt. %.

[0319] The first cracker stream is cracked in a first coil or tube. The second cracker stream is cracked in a second coil or tube. Both the first and second cracker streams and the first and second coils or tubes can be within the same cracker furnace.

[0320] The second cracker stream can have none of the r-pyoil or less of said r-pyoil, by weight, than the first cracker feed stream. Also, the second cracker stream can contain only non-recycle cracker feed in the second coil or tube. The second cracker feed stream can be predominantly C_2 to C_4 , or hydrocarbons (e.g., non-recycle content), or ethane, propane, or butane, in each case in amounts of at least 55, 60, 65, 70, 75, 80, 85, or at least 90 weight percent based on the second cracker feed within a second coil or tube. If r-pyoil is included in the second cracker feed, the amount of such r-pyoil can be at least 10% less, 20, 30, 40, 50, 60, 70, 80, 90, 95, 97, or 99% less by weight than the amount of r-pyoil in the first cracker feed.

[0321] In an embodiment or in combination with any embodiment mentioned herein or in combination with any of the mentioned embodiments, although not shown, a vaporizer can be provided to vaporize a condensed feedstock of C_2 - C_5 hydrocarbons 350 to ensure that the feed to the inlet of the coils in the convection box 312, or the inlet of the convection zone 310, is a predominately vapor phase feed.

[0322] The cracking furnace shown in FIG. 5 includes a convection section or zone 310, a radiant section or zone 320, and a cross-over section or zone 330 located between the convection and radiant sections 310 and 320. The convection section 310 is the portion of the furnace 300 that receives heat from hot flue gases and includes a bank of tubes or coils 324 through which a cracker stream 350

passes. In the convection section 310, the cracker stream 350 is heated by convection from the hot flue gases passing therethrough. The radiant section 320 is the section of the furnace 300 into which heat is transferred into the heater tubes primarily by radiation from the high-temperature gas. The radiant section 320 also includes a plurality of burners 326 for introducing heat into the lower portion of the furnace. The furnace includes a fire box 322 which surrounds and houses the tubes within the radiant section 320 and into which the burners are oriented. The cross-over section 330 includes piping for connecting the convection 310 and radiant sections 320 and may transfer the heated cracker stream internally or externally from one section to the other within the furnace 300.

[0323] As hot combustion gases ascend upwardly through the furnace stack, the gases may pass through the convection section 310, wherein at least a portion of the waste heat may be recovered and used to heat the cracker stream passing through the convection section 310. In an embodiment or in combination with any of the embodiments mentioned herein, the cracking furnace 300 may have a single convection (preheat) section 310 and a single radiant 320 section, while, in other embodiments, the furnace may include two or more radiant sections sharing a common convection section. At least one induced draft (I.D.) fan 316 near the stack may control the flow of hot flue gas and heating profile through the furnace, and one or more heat exchangers 340 may be used to cool the furnace effluent 370. In an embodiment or in combination with any of the embodiments mentioned herein (not shown), a liquid quench may be used in addition to, or alternatively with, the exchanger (e.g., transfer line heat exchanger or TLE) shown in FIG. 5, for cooling the cracked olefin-containing effluent.

[0324] The furnace 300 also includes at least one furnace coil 324 through which the cracker streams pass through the furnace. The furnace coils 324 may be formed of any material inert to the cracker stream and suitable for withstanding high temperatures and thermal stresses within the furnace. The coils may have any suitable shape and can, for example, have a circular or oval cross-sectional shape.

[0325] The coils in the convection section 310, or tubes within the coil, may have a diameter of at least 1, or at least 1.5, or at least 2, or at least 2.5, or at least 3, or at least 3.5, or at least 4, or at least 4.5, or at least 5, or at least 5.5, or at least 6, or at least 6.5, or at least 7, or at least 7.5, or at least 8, or at least 8.5, or at least 9, or at least 9.5, or at least 10, or at least 10.5, in each case cm and/or not more than 12, or not more than 11.5, or not more than 11, 1 or not more than 0.5, or not more than 10, or not more than 9.5, or not more than 9, or not more than 8.5, or not more than 8, or not more than 7.5, or not more than 7, or not more than 6.5, in each case cm. All or a portion of one or more coils can be substantially straight, or one or more of the coils may include a helical, twisted, or spiral segment. One or more of the coils may also have a U-tube or split U-tube design. In an embodiment or in combination with any of the embodiments mentioned herein, the interior of the tubes may be smooth or substantially smooth, or a portion (or all) may be roughened in order to minimize coking. Alternatively, or in addition, the inner portion of the tube may include inserts or fins and/or surface metal additives to prevent coke build up.

[0326] In an embodiment or in combination with any of the embodiments mentioned herein, all or a portion of the furnace coil or coils 324 passing through in the convection

section 310 may be oriented horizontally, while all, or at least a portion of, the portion of the furnace coil passing through the radiant section 322 may be oriented vertically. In an embodiment or in combination with any of the embodiments mentioned herein, a single furnace coil may run through both the convection and radiant section. Alternatively, at least one coil may split into two or more tubes at one or more points within the furnace, so that cracker stream may pass along multiple paths in parallel. For example, the cracker stream (including r-pyoil) 350 may be introduced into multiple coil inlets in the convection zone 310, or into multiple tube inlets in the radiant 320 or cross-over sections 330. When introduced into multiple coil or tube inlets simultaneously, or nearly simultaneously, the amount of r-pyoil introduced into each coil or tube may not be regulated. In an embodiment or in combination with any of the embodiments mentioned herein, the r-pyoil and/or cracker stream may be introduced into a common header, which then channels the r-pyoil into multiple coil or tube inlets.

[0327] A single furnace can have at least 1, or at least 2, or at least 3, or at least 4, or at least 5, or at least 6, or at least 7, or at least 8 or more, in each case coils. Each coil can be from 5 to 100, 10 to 75, or 20 to 50 meters in length and can include at least 1, or at least 2, or at least 3, or at least 4, or at least 5, or at least 6, or at least 7, or at least 8, or at least 10, or at least 12, or at least 14 or more tubes. Tubes of a single coil may be arranged in many configurations and in an embodiment or in combination with any of the embodiments mentioned herein may be connected by one or more 180° (“U”) bends. One example of a furnace coil 410 having multiple tubes 420 is shown in FIG. 6.

[0328] An olefin plant can have a single cracking furnace, or it can have at least 2, or at least 3, or at least 4, or at least 5, or at least 6, or at least 7, or at least 8 or more cracking furnaces operated in parallel. Any one or each furnace(s) may be gas cracker, or a liquid cracker, or a split furnace. In an embodiment or in combination with any embodiment mentioned herein or in combination with any of the mentioned embodiments, the furnace is a gas cracker receiving a cracker feed stream containing at least 50 wt. %, or at least 75 wt. %, or at least 85 wt. % or at least 90 wt. % ethane, propane, LPG, or a combination thereof through the furnace, or through at least one coil in a furnace, or through at least one tube in the furnace, based on the weight of all cracker feed to the furnace. In an embodiment or in combination with any embodiment mentioned herein or in combination with any of the mentioned embodiments, the furnace is a liquid or naphtha cracker receiving a cracker feed stream containing at least 50 wt. %, or at least 75 wt. %, or at least 85 wt. % liquid (when measured at 25° C. and 1 atm) hydrocarbons having a carbon number from C₅-C₂₂, through the furnace, or through at least one coil in a furnace, or through at least one tube in the furnace, based on the weight of all cracker feed to the furnace. In an embodiment or in combination with any embodiment mentioned herein or in combination with any of the mentioned embodiments, the cracker is a split furnace receiving a cracker feed stream containing at least 50 wt. %, or at least 75 wt. %, or at least 85 wt. % or at least 90 wt. % ethane, propane, LPG, or a combination thereof through the furnace, or through at least one coil in a furnace, or through at least one tube in the furnace, and receiving a cracker feed stream containing at least 0.5 wt. %, or at least 0.1 wt. %, or at least 1 wt. %, or

at least 2 wt. %, or at least 5 wt. %, or at least 7 wt. %, or at least 10 wt. %, or at least 13 wt. %, or at least 15 wt. %, or at least 20 wt. % liquid and/or r-pyoil (when measured at 25° C. and 1 atm), each based on the weight of all cracker feed to the furnace.

[0329] Turning now to FIG. 7, several possible locations for introducing the r-pyoil containing feed stream and the non-recycle cracker feed stream into a cracking furnace are shown.

[0330] In an embodiment or in combination with any of the embodiments mentioned herein, an r-pyoil containing feed stream 550 may be combined with the non-recycle cracker feed 552 upstream of the convection section to form a combined cracker feed stream 554, which may then be introduced into the convection section 510 of the furnace. Alternatively, or in addition, the r-pyoil containing feed 550 may be introduced into a first furnace coil, while the non-recycle cracker feed 552 is introduced into a separate or second furnace coil, within the same furnace, or within the same convection zone. Both streams may then travel in parallel with one another through the convection section 510 within a convection box 512, cross-over 530, and radiant section 520 within a radiant box 522, such that each stream is substantially fluidly isolated from the other over most, or all, of the travel path from the inlet to the outlet of the furnace. The pyoil stream introduced into any heating zone within the convection section 510 can flow through the convection section 510 and flow through as a vaporized stream 514b into the radiant box 522. In other embodiments, the r-pyoil containing feed stream 550 may be introduced into the non-recycle cracker stream 552 as it passes through a furnace coil in the convection section 510 flowing into the cross-over section 530 of the furnace to form a combined cracker stream 514a, as also shown in FIG. 7.

[0331] In an embodiment or in combination with any embodiment mentioned herein or in combination with any of the mentioned embodiments, the r-pyoil 550 may be introduced into the first furnace coil, or an additional amount introduced into the second furnace coil, at either a first heating zone or a second heating zone as shown in FIG. 7. The r-pyoil 550 may be introduced into the furnace coil at these locations through a nozzle. A convenient method for introducing the feed of r-pyoil is through one or more dilution steam feed nozzles that are used to feed steam into the coil in the convection zone. The service of one or more dilution steam nozzles may be employed to inject r-pyoil, or a new nozzle can be fastened to the coil dedicated to the injection of the r-pyoil. In an embodiment or in combination with any embodiment mentioned herein or in combination with any of the mentioned embodiments, both steam and r-pyoil can be co-fed through a nozzle into the furnace coil downstream of the inlet to the coil and upstream of a crossover, optionally at the first or second heating zone within the convection zone as shown in FIG. 7.

[0332] The non-recycle cracker feed stream may be mostly liquid and have a vapor fraction of less than 0.25 by volume, or less than 0.25 by weight, or it may be mostly vapor and have a vapor fraction of at least 0.75 by volume, or at least 0.75 by weight, when introduced into the furnace and/or when combined with the r-pyoil containing feed. Similarly, the r-pyoil containing feed may be mostly vapor or mostly liquid when introduced into the furnace and/or when combined with the non-recycle cracker stream.

[0333] In an embodiment or in combination with any of the embodiments mentioned herein, at least a portion or all of the r-pyoil stream or cracker feed stream may be preheated prior to being introduced into the furnace. As shown in FIG. 8, the preheating can be performed with an indirect heat exchanger 618 heated by a heat transfer media (such as steam, hot condensate, or a portion of the olefin-containing effluent) or via a direct fired heat exchanger 618. The preheating step can vaporize all or a portion of the stream comprising r-pyoil and may, for example, vaporize at least 50, 55, 60, 65, 70, 75, 80, 85, 90, 95, or 99 weight percent of the stream comprising r-pyoil.

[0334] The preheating, when performed, can increase the temperature of the r-pyoil containing stream to a temperature that is within about 50, 45, 40, 35, 30, 25, 20, 15, 10, 5, or 2° C. of the bubble point temperature of the r-pyoil containing stream. Additionally, or in the alternative, the preheating can increase the temperature of the stream comprising r-pyoil to a temperature at least 5, 10, 15, 20, 25, 30, 35, 40, 45, 50, 55, 60, 65, 70, 75, 80, 85, 90, or 100° C. below the coking temperature of the stream. In an embodiment or in combination with any of the embodiments mentioned herein, the preheated r-pyoil stream can have a temperature of at least 200, 225, 240, 250, or 260° C. and/or not more than 375, 350, 340, 330, 325, 320, or 315° C., or at least 275, 300, 325, 350, 375, or 400° C. and/or not more than 600, 575, 550, 525, 500, or 475° C. When the atomized liquid (as explained below) is injected into the vapor phase, heated cracker stream, the liquid may rapidly evaporate such that, for example, the entire combined cracker stream is vapor (e.g., 100 percent vapor) within 5, 4, 3, 2, or 1 second after injection.

[0335] In an embodiment or in combination with any of the embodiments mentioned herein, the heated r-pyoil stream (or cracker stream comprising the r-pyoil and the non-recycle cracker stream) can optionally be passed through a vapor-liquid separator to remove any residual heavy or liquid components, when present. The resulting light fraction may then be introduced into the cracking furnace, alone or in combination with one or more other cracker streams as described in various embodiments herein. For example, in an embodiment or in combination with any of the embodiments mentioned herein, the r-pyoil stream can comprise at least 1, 2, 5, 8, 10, or 12 weight percent C_{15} and heavier components. The separation can remove at least 50, 55, 60, 65, 70, 75, 80, 85, 90, 95, or 99 weight percent of the heavier components from the r-pyoil stream.

[0336] Turning back to FIG. 7, the cracker feed stream (either alone or when combined with the r-pyoil feed stream) may be introduced into a furnace coil at or near the inlet of the convection section. The cracker stream may then pass through at least a portion of the furnace coil in the convection section 510, and dilution steam may be added at some point in order to control the temperature and cracking severity in the furnace. In an embodiment or in combination with any of the embodiments mentioned herein, the steam may be added upstream of or at the inlet to the convection section, or it may be added downstream of the inlet to the convection section—either in the convection section, at the cross-over section, or upstream of or at the inlet to the radiant section. Similarly, the stream comprising the r-pyoil and the non-recycle cracker stream (alone or combined with the steam) may also be introduced into or upstream or at the inlet to the convection section, or downstream of the inlet to

the convection section—either within the convection section, at the cross-over, or at the inlet to the radiant section. The steam may be combined with the r-pyoil stream and/or cracker stream and the combine stream may be introduced at one or more of these locations, or the steam and r-pyoil and/or non-recycle cracker stream may be added separately.

[0337] When combined with steam and fed into or near the cross-over section of the furnace, the r-pyoil and/or cracker stream can have a temperature of 500, 510, 520, 530, 540, 550, 560, 570, 580, 590, 600, 610, 620, 630, 640, 650, 660, 670, or 680° C. and/or not more than 850, 840, 830, 820, 810, 800, 790, 780, 770, 760, 750, 740, 730, 720, 710, 705, 700, 695, 690, 685, 680, 675, 670, 665, 660, 655, or 650° C. The resulting steam and r-pyoil stream can have a vapor fraction of at least 0.75, 0.80, 0.85, 0.90, or at least 0.95 by weight, or at least 0.75, 0.80, 0.85, 0.90, and 0.95 by volume.

[0338] When combined with steam and fed into or near the inlet to the convection section 510, the r-pyoil and/or cracker stream can have a temperature of at least 30, 35, 40, 45, 50, 55, 60, or 65 and/or not more than 100, 90, 80, 70, 60, 50, or 45° C.

[0339] The amount of steam added may depend on the operating conditions, including feed type and desired product, but can be added to achieve a steam-to-hydrocarbon ratio can be at least 0.10:1, 0.15:1, 0.20:1, 0.25:1, 0.27:1, 0.30:1, 0.32:1, 0.35:1, 0.37:1, 0.40:1, 0.42:1, 0.45:1, 0.47:1, 0.50:1, 0.52:1, 0.55:1, 0.57:1, 0.60:1, 0.62:1, 0.65:1 and/or not more than about 1:1, 0.95:1, 0.90:1, 0.85:1, 0.80:1, 0.75:1, 0.72:1, 0.70:1, 0.67:1, 0.65:1, 0.62:1, 0.60:1, 0.57:1, 0.55:1, 0.52:1, 0.50:1, or it can be in the range of from 0.1:1 to 1.0:1, 0.15:1 to 0.9:1, 0.2:1 to 0.8:1, 0.3:1 to 0.75:1, or 0.4:1 to 0.6:1. When determining the “steam-to-hydrocarbon” ratio, all hydrocarbon components are included and the ratio is by weight. In an embodiment or in combination with any of the embodiments mentioned herein, the steam may be produced using separate boiler feed water/steam tubes heated in the convection section of the same furnace (not shown in FIG. 7). Steam may be added to the cracker feed (or any intermediate cracker stream within the furnace) when the cracker stream has a vapor fraction of 0.60 to 0.95, or 0.65 to 0.90, or 0.70 to 0.90.

[0340] When the r-pyoil containing feed stream is introduced into the cracking furnace separately from a non-recycle feed stream, the molar flow rate of the r-pyoil and/or the r-pyoil containing stream may be different than the molar flow rate of the non-recycle feed stream. In one embodiment or in combination with any other mentioned embodiment, there is provided a method for making one or more olefins by:

[0341] (a) feeding a first cracker stream having r-pyoil to a first tube inlet in a cracker furnace;

[0342] (b) feeding a second cracker stream containing, or predominately containing C_2 to C_4 hydrocarbons to a second tube inlet in the cracker furnace, wherein said second tube is separate from said first tube and the total molar flow rate of the first cracker stream fed at the first tube inlet is lower than the total molar flow rate of the second cracker stream to the second tube inlet, calculated without the effect of steam. The feeding of step (a) and step (b) can be to respective coil inlets.

[0343] For example, the molar flow rate of the r-pyoil or the first cracker stream as it passes through a tube in the cracking furnace may be at least 5, 7, 10, 12, 15, 17, 20, 22, 25, 27, 30, 35, 40, 45, 50, 55, or 60 percent lower than the

flow rate of the hydrocarbon components (e.g., C₂-C₄ or C₅-C₂₂) components in the non-recycle feed stream, or the second cracker stream, passing through another or second tube. When steam is present in both the r-pyoil containing stream, or first cracker stream, and in the second cracker stream or the non-recycle feed stream, the total molar flow rate of the r-pyoil containing stream, or first cracker stream, (including r-pyoil and dilution steam) may be at least 5, 7, 10, 12, 15, 17, 20, 22, 25, 27, 30, 35, 40, 45, 50, 55, or 60 percent higher than the total molar flow rate (including hydrocarbon and dilution steam) of the non-recycle cracker feedstock, or second cracker stream (wherein the percentage is calculated as the difference between the two molar flow rates divided by the flow rate of the non-recycle stream).

[0344] In an embodiment or in combination with any of the embodiments mentioned herein, the molar flow rate of the r-pyoil in the r-pyoil containing feed stream (first cracker stream) within the furnace tube may be at least 0.01, 0.02, 0.025, 0.03, 0.035 and/or not more than 0.06, 0.055, 0.05, 0.045 kmol-lb/hr lower than the molar flow rate of the hydrocarbon (e.g., C₂-C₄ or C₅-C₂₂) in the non-recycle cracker stream (second cracker stream). In an embodiment or in combination with any of the embodiments mentioned herein, the molar flow rates of the r-pyoil and the cracker feed stream may be substantially similar, such that the two molar flow rates are within 0.005, 0.001, or 0.0005 kmol-lb/hr of one another. The molar flow rate of the r-pyoil in the furnace tube can be at least 0.0005, 0.001, 0.0025, 0.005, 0.01, 0.02, 0.03, 0.04, 0.05, 0.06, 0.07, 0.08, 0.09, 0.10, 0.11, 0.12, 0.13, 0.14, or 0.15 kilo moles-pound per hour (kmol-lb/hr) and/or not more than 0.25, 0.24, 0.23, 0.22, 0.21, 0.20, 0.19, 0.18, 0.17, 0.16, 0.15, 0.14, 0.13, 0.08, 0.05, 0.025, 0.01, or 0.008 kmol-lb/hr, while the molar flow rate of the hydrocarbon components in the other coil or coils can be at least 0.02, 0.03, 0.04, 0.05, 0.06, 0.07, 0.08, 0.09, 0.10, 0.11, 0.12, 0.13, 0.14, 0.15, 0.16, 0.17, 0.18 and/or not more than 0.30, 0.29, 0.28, 0.27, 0.26, 0.25, 0.24, 0.23, 0.22, 0.21, 0.20, 0.19, 0.18, 0.17, 0.16, 0.15 kmol-lb/hr.

[0345] In an embodiment or in combination with any of the embodiments mentioned herein, the total molar flow rate of the r-pyoil containing stream (first cracker stream) can be at least 0.01, 0.02, 0.03, 0.04, 0.05, 0.06, 0.07, 0.08, 0.09 and/or not more than 0.30, 0.25, 0.20, 0.15, 0.13, 0.10, 0.09, 0.08, 0.07, or 0.06 kmol-lb/hr lower than the total molar flow rate of the non-recycle feed stream (second cracker stream), or the same as the total molar flow rate of the non-recycle feed stream (second cracker stream). The total molar flow rate of the r-pyoil containing stream (first cracker stream) can be at least 0.01, 0.02, 0.03, 0.04, 0.05, 0.06, 0.07 and/or not more than 0.10, 0.09, 0.08, 0.07, or 0.06 kmol-lb/hr higher than the total molar flow rate of the second cracker stream, while the total molar flow rate of the non-recycle feed stream (second cracker stream) can be at least 0.20, 0.21, 0.22, 0.23, 0.24, 0.25, 0.26, 0.27, 0.28, 0.29, 0.30, 0.31, 0.32, 0.33 and/or not more than 0.50, 0.49, 0.48, 0.47, 0.46, 0.45, 0.44, 0.43, 0.42, 0.41, 0.40 kmol-lb/hr.

[0346] In an embodiment or in combination with any of the embodiments mentioned herein, the r-pyoil containing stream, or first cracker stream, has a steam-to-hydrocarbon ratio that is at least 5, 10, 15, 20, 25, 30, 35, 40, 45, 50, 55, 60, 65, 70, 75, or 80 percent different than the steam-to-hydrocarbon ratio of the non-recycle feed stream, or second cracker stream. The steam-to-hydrocarbon ratio can be higher or lower. For example, the steam-to-hydrocarbon

ratio of the r-pyoil containing stream or first cracker stream can be at least 0.01, 0.025, 0.05, 0.075, 0.10, 0.125, 0.15, 0.175, or 0.20 and/or not more than 0.3, 0.27, 0.25, 0.22, or 0.20 different than the steam-to-hydrocarbon ratio of the non-recycle feed stream or second cracker stream. The steam-to-hydrocarbon ratio of the r-pyoil containing stream or first cracker stream can be at least 0.3, 0.32, 0.35, 0.37, 0.4, 0.42, 0.45, 0.47, 0.5 and/or not more than 0.7, 0.67, 0.65, 0.62, 0.6, 0.57, 0.55, 0.52, or 0.5, and the steam-to-hydrocarbon ratio of the non-recycle cracker feed or second cracker stream can be at least 0.02, 0.05, 0.07, 0.10, 0.12, 0.15, 0.17, 0.20, 0.25 and/or not more than 0.45, 0.42, 0.40, 0.37, 0.35, 0.32, or 0.30.

[0347] In an embodiment or in combination with any embodiments mentioned herein, the temperature of the r-pyoil containing stream as it passes through a cross-over section in the cracking furnace can be different than the temperature of the non-recycle cracker feed as it passes through the cross-over section, when the streams are introduced into and passed through the furnace separately. For example, the temperature of the r-pyoil stream (or first cracker stream) as it passes through the cross-over section may be at least 0.01, 0.5, 1, 1.5, 2, 5, 10, 15, 20, 25, 30, 35, 40, 45, 50, 55, 60, 65, 70, or 75 percent different than the temperature of the non-recycle hydrocarbon stream, or second cracker stream (e.g., C₂-C₄ or C₅-C₂₂) passing through the cross-over section in another coil. The percentage can be calculated based on the temperature of the non-recycle stream according to the following formula:

$$\frac{(\text{temperature of r-pyoil stream} - \text{temperature of non-recycle cracker stream})}{(\text{temperature of non-recycle cracker stream})}, \text{ expressed as a percentage.}$$

[0348] The difference can be higher or lower. The average temperature of the r-pyoil containing stream at the cross-over section can be at least 400, 425, 450, 475, 500, 525, 550, 575, 580, 585, 590, 595, 600, 605, 610, 615, 620, or 625° C. and/or not more than 705, 700, 695, 690, 685, 680, 675, 670, 665, 660, 655, 650, 625, 600, 575, 550, 525, or 500° C., while the average temperature of the non-recycle cracker feed can be at least 401, 426, 451, 476, 501, 526, 551, 560, 565, 570, 575, 580, 585, 590, 595, 600, 605, 610, 615, 620, or 625° C. and/or not more than 705, 700, 695, 690, 685, 680, 675, 670, 665, 660, 655, 650, 625, 600, 575, 550, 525, or 500° C.

[0349] The heated cracker stream, which usually has a temperature of at least 500, 510, 520, 530, 540, 550, 560, 570, 580, 590, 600, 610, 620, 630, 640, 650, 660, 670, or 680° C. and/or not more than 850, 840, 830, 820, 810, 800, 790, 780, 770, 760, 750, 740, 730, 720, 710, 705, 700, 695, 690, 685, 680, 675, 670, 665, 660, 655, or 650° C., or in the range of from 500 to 710° C., 620 to 740° C., 560 to 670° C., or 510 to 650° C., may then pass from the convection section of the furnace to the radiant section via the cross-over section.

[0350] In an embodiment or in combination with any of the embodiments mentioned herein, the r-pyoil containing feed stream may be added to the cracker stream at the cross-over section. When introduced into the furnace in the cross-over section, the r-pyoil may be at least partially vaporized by, for example, preheating the stream in a direct or indirect heat exchanger. When vaporized or partially vaporized, the r-pyoil containing stream has a vapor fraction of at least 0.5, 0.55, 0.6, 0.65, 0.7, 0.75, 0.8, 0.85, 0.9, 0.95,

or 0.99 by weight, or in one embodiment or in combination with any mentioned embodiments, by volume.

[0351] When the r-pyoil containing stream is atomized prior to entering the cross-over section, the atomization can be performed using one or more atomizing nozzles. The atomization can take place within or outside the furnace. In an embodiment or in combination with any of the embodiments mentioned herein, an atomizing agent may be added to the r-pyoil containing stream during or prior to its atomization. The atomizing agent can include steam, or it may include predominantly ethane, propane, or combinations thereof. When used the atomizing agent may be present in the stream being atomized (e.g., the r-pyoil containing composition) in an amount of at least 1, 2, 4, 5, 8, 10, 12, 15, 10, 25, or 30 weight percent and/or not more than 50, 45, 40, 35, 30, 25, 20, 15, or 10 weight percent.

[0352] The atomized or vaporized stream of r-pyoil may then be injected into or combined with the cracker stream passing through the cross-over section. At least a portion of the injecting can be performed using at least one spray nozzle. At least one of the spray nozzles can be used to inject the r-pyoil containing stream into the cracker feed stream may be oriented to discharge the atomized stream at an angle within about 45, 50, 35, 30, 25, 20, 15, 10, 5, or 0° from the vertical. The spray nozzle or nozzles may also be oriented to discharge the atomized stream into a coil within the furnace at an angle within about 30, 25, 20, 15, 10, 8, 5, 2, or 1° of being parallel, or parallel, with the axial centerline of the coil at the point of introduction. The step of injecting the atomized r-pyoil may be performed using at least two, three, four, five, six or more spray nozzles, in the cross-over and/or convection section of the furnace.

[0353] In an embodiment or in combination with any embodiments mentioned herein, atomized r-pyoil can be fed, alone or in combination with an at least partially non-recycle cracker stream, into the inlet of one or more coils in the convection section of the furnace. The temperature of such an atomization can be at least 30, 35, 40, 45, 50, 55, 60, 65, 70, 75, or 80° C. and/or not more than 120, 110, 100, 90, 95, 80, 85, 70, 65, 60, or 55° C.

[0354] In an embodiment or in combination with any embodiments mentioned herein, the temperature of the atomized or vaporized stream can be at least 5, 10, 15, 20, 25, 30, 35, 40, 45, 50, 75, 100, 125, 150, 175, 200, 225, 250, 275, 300, 325, 350° C. and/or not more than 550, 525, 500, 475, 450, 425, 400, 375, 350, 325, 300, 275, 250, 225, 200, 175, 150, 125, 100, 90, 80, 75, 70, 60, 55, 50, 45, 40, 30, or 25° C. cooler than the temperature of the cracker stream to which it is added. The resulting combined cracker stream comprises a continuous vapor phase with a discontinuous liquid phase (or droplets or particles) dispersed there-through. The atomized liquid phase may comprise r-pyoil, while the vapor phase may include predominantly C₂-C₄ components, ethane, propane, or combinations thereof. The combined cracker stream may have a vapor fraction of at least 0.7, 0.75, 0.8, 0.85, 0.9, 0.95, or 0.99 by weight, or in one embodiment or in combination with any mentioned embodiments, by volume.

[0355] The temperature of the cracker stream passing through the cross-over section can be at least 500, 510, 520, 530, 540, 550, 555, 560, 565, 570, 575, 580, 585, 590, 595, 600, 605, 610, 615, 620, 625, 630, 635, 640, 645, 650, 660, 670, or 680° C. and/or not more than 850, 840, 830, 820, 810, 800, 795, 790, 785, 780, 775, 770, 765, 760, 755, 750,

745, 740, 735, 730, 725, 720, 715, 710, 705, 700, 695, 690, 685, 680, 675, 670, 665, 660, 655, 650, 645, 640, 635, or 630° C., or in the range of from 620 to 740° C., 550 to 680° C., 510 to 630° C.

[0356] The resulting cracker feed stream then passes into the radiant section. In an embodiment or in combination with any of the embodiments mentioned herein, the cracker stream (with or without the r-pyoil) from the convection section may be passed through a vapor-liquid separator to separate the stream into a heavy fraction and a light fraction before cracking the light fraction further in the radiant section of the furnace. One example of this is illustrated in FIG. 8.

[0357] In an embodiment or in combination with any of the embodiments mentioned herein, the vapor-liquid separator **640** may comprise a flash drum, while in other embodiments it may comprise a fractionator. As the stream **614** passes through the vapor-liquid separator **640**, a gas stream impinges on a tray and flows through the tray, as the liquid from the tray fall to an underflow **642**. The vapor-liquid separator may further comprise a demister or chevron or other device located near the vapor outlet for preventing liquid carry-over into the gas outlet from the vapor-liquid separator **640**.

[0358] Within the convection section **610**, the temperature of the cracker stream may increase by at least 50, 75, 100, 150, 175, 200, 225, 250, 275, or 300° C. and/or not more than about 650, 600, 575, 550, 525, 500, 475, 450, 425, 400, 375, 350, 325, 300, or 275° C., so that the passing of the heated cracker stream exiting the convection section **610** through the vapor-liquid separator **640** may be performed at a temperature of least 400, 425, 450, 475, 500, 525, 550, 575, 600, 625, 650° C. and/or not more than 800, 775, 750, 725, 700, 675, 650, 625° C. When heavier components are present, at least a portion or nearly all of the heavy components may be removed in the heavy fraction as an underflow **642**. At least a portion of the light fraction **644** from the separator **640** may be introduced into the cross-over section or the radiant zone tubes **624** after the separation, alone or in combination with one or more other cracker streams, such as, for example, a predominantly C₅-C₂₂ hydrocarbon stream or a C₂-C₄ hydrocarbon stream.

[0359] Referencing FIGS. 5 and 6, the cracker feed stream (either the non-recycle cracker feed stream or when combined with the r-pyoil feed stream) **350** and **650** may be introduced into a furnace coil at or near the inlet of the convection section. The cracker feed stream may then pass through at least a portion of the furnace coil in the convection section **310** and **610**, and dilution steam **360** and **660** may be added at some point in order to control the temperature and cracking severity in the radiant section **320** and **620**. The amount of steam added may depend on the furnace operating conditions, including feed type and desired product distribution, but can be added to achieve a steam-to-hydrocarbon ratio in the range of from 0.1 to 1.0, 0.15 to 0.9, 0.2 to 0.8, 0.3 to 0.75, or 0.4 to 0.6, calculated by weight. In an embodiment or in combination with any of the embodiments mentioned herein, the steam may be produced using separate boiler feed water/steam tubes heated in the convection section of the same furnace (not shown in FIG. 5). Steam **360** and **660** may be added to the cracker feed (or any intermediate cracker feed stream within the furnace) when the cracker feed stream has a vapor fraction of 0.60 to 0.95,

or 0.65 to 0.90, or 0.70 to 0.90 by weight, or in one embodiment or in combination with any mentioned embodiments, by volume.

[0360] The heated cracker stream, which usually has a temperature of at least 500, or at least 510, or at least 520, or at least 530, or at least 540, or at least 550, or at least 560, or at least 570, or at least 580, or at least 590, or at least 600, or at least 610, or at least 620, or at least 630, or at least 640, or at least 650, or at least 660, or at least 670, or at least 680, in each case °C and/or not more than 850, or not more than 840, or not more than 830, or not more than 820, or not more than 810, or not more than 800, or not more than 790, or not more than 780, or not more than 770, or not more than 760, or not more than 750, or not more than 740, or not more than 730, or not more than 720, or not more than 710, or not more than 705, or not more than 700, or not more than 695, or not more than 690, or not more than 685, or not more than 680, or not more than 675, or not more than 670, or not more than 665, or not more than 660, or not more than 655, or not more than 650, in each case °C, or in the range of from 500 to 710° C., 620 to 740° C., 560 to 670° C., or 510 to 650° C., may then pass from the convection section **610** of the furnace to the radiant section **620** via the cross-over section **630**. In an embodiment or in combination with any of the embodiments mentioned herein, the r-pyoil containing feed stream **550** may be added to the cracker stream at the cross-over section **530** as shown in FIG. 6. When introduced into the furnace in the cross-over section, the r-pyoil may be at least partially vaporized or atomized prior to being combined with the cracker stream at the cross-over. The temperature of the cracker stream passing through the cross-over **530** or **630** can be at least 400, 425, 450, 475, or at least 500, or at least 510, or at least 520, or at least 530, or at least 540, or at least 550, or at least 560, or at least 570, or at least 580, or at least 590, or at least 600, or at least 610, or at least 620, or at least 630, or at least 640, or at least 650, or at least 660, or at least 670, or at least 680, in each case ° C. and/or not more than 850, or not more than 840, or not more than 830, or not more than 820, or not more than 810, or not more than 800, or not more than 790, or not more than 780, or not more than 770, or not more than 760, or not more than 750, or not more than 740, or not more than 730, or not more than 720, or not more than 710, or not more than 705, or not more than 700, or not more than 695, or not more than 690, or not more than 685, or not more than 680, or not more than 675, or not more than 670, or not more than 665, or not more than 660, or not more than 655, or not more than 650, or not more than 645, in each case ° C., or in the range of from 620 to 740° ° C., 550 to 680° C., 510 to 630° ° C.

[0361] The resulting cracker feed stream then passes through the radiant section, wherein the r-pyoil containing feed stream is thermally cracked to form lighter hydrocarbons, including olefins such as ethylene, propylene, and/or butadiene. The residence time of the cracker feed stream in the radiant section can be at least 0.1, or at least 0.15, or at least 0.2, or at least 0.25, or at least 0.3, or at least 0.35, or at least 0.4, or at least 0.45, in each case seconds and/or not more than 2, or not more than 1.75, or not more than 1.5, or not more than 1.25, or not more than 1, or not more than 0.9, or not more than 0.8, or not more than 0.75, or not more than 0.7, or not more than 0.65, or not more than 0.6, or not more than 0.5, in each case seconds. The temperature at the inlet of the furnace coil is at least 500, or at least 510, or at least 520, or at least 530, or at least 540, or at least 550, or at least

560, or at least 570, or at least 580, or at least 590, or at least 600, or at least 610, or at least 620, or at least 630, or at least 640, or at least 650, or at least 660, or at least 670, or at least 680, in each case ° C. and/or not more than 850, or not more than 840, or not more than 830, or not more than 820, or not more than 810, or not more than 800, or not more than 790, or not more than 780, or not more than 770, or not more than 760, or not more than 750, or not more than 740, or not more than 730, or not more than 720, or not more than 710, or not more than 705, or not more than 700, or not more than 695, or not more than 690, or not more than 685, or not more than 680, or not more than 675, or not more than 670, or not more than 665, or not more than 660, or not more than 655, or not more than 650, in each case ° ° C., or in the range of from 550 to 710° C., 560 to 680° C., or 590 to 650° ° C., or 580 to 750° ° C., 620 to 720° ° C., or 650 to 710° C.

[0362] The coil outlet temperature can be at least 640, or at least 650, or at least 660, or at least 670, or at least 680, or at least 690, or at least 700, or at least 720, or at least 730, or at least 740, or at least 750, or at least 760, or at least 770, or at least 780, or at least 790, or at least 800, or at least 810, or at least 820, in each case ° C. and/or not more than 1000, or not more than 990, or not more than 980, or not more than 970, or not more than 960, or not more than 950, or not more than 940, or not more than 930, or not more than 920, or not more than 910, or not more than 900, or not more than 890, or not more than 880, or not more than 875, or not more than 870, or not more than 860, or not more than 850, or not more than 840, or not more than 830, in each case ° C., in the range of from 730 to 900° C., 750 to 875° C., or 750 to 850° C.

[0363] The cracking performed in the coils of the furnace may include cracking the cracker feed stream under a set of processing conditions that include a target value for at least one operating parameter. Examples of suitable operating parameters include, but are not limited to maximum cracking temperature, average cracking temperature, average tube outlet temperature, maximum tube outlet temperature, and average residence time. When the cracker stream further includes steam, the operating parameters may include hydrocarbon molar flow rate and total molar flow rate. When two or more cracker streams pass through separate coils in the furnace, one of the coils may be operated under a first set of processing conditions and at least one of the other coils may be operated under a second set of processing conditions. At least one target value for an operating parameter from the first set of processing conditions may differ from a target value for the same parameter in the second set of conditions by at least 0.01, 0.03, 0.05, 0.1, 0.25, 0.5, 1, 2, 5, 7, 10, 15, 20, 25, 30, 35, 40, 45, 50, 55, 60, 65, 70, 75, 80, 85, 90, or 95 percent and/or not more than about 95, 90, 85, 80, 75, 70, 65, 60, 55, 50, 45, 40, 35, 30, 25, 20, or 15 percent. Examples include 0.01 to 30, 0.01 to 20, 0.01 to 15, 0.03 to 15 percent. The percentage is calculated according to the following formula:

$$\frac{[(\text{measured value for operating parameter}) - (\text{target value for operating parameter})]}{[(\text{target value for operating parameter})]}, \text{ expressed as a percentage. As used herein, the term "different," means higher or lower.}$$

[0364] The coil outlet temperature can be at least 640, 650, 660, 670, 680, 690, 700, 720, 730, 740, 750, 760, 770, 780, 790, 800, 810, 820° C. and/or not more than 1000, 990, 980, 970, 960, 950, 940, 930, 920, 910, 900, 890, 880, 875, 870,

860, 850, 840, 830° C., in the range of from 730 to 900° C., 760 to 875° C., or 780 to 850° C.

[0365] In an embodiment or in combination with any of the embodiments mentioned herein, the addition of r-pyoil to a cracker feed stream may result in changes to one or more of the above operating parameters, as compared to the value of the operating parameter when an identical cracker feed stream is processed in the absence of r-pyoil. For example, the values of one or more of the above parameters may be at least 0.01, 0.03, 0.05, 0.1, 0.25, 0.5, 1, 2, 5, 7, 10, 15, 20, 25, 30, 35, 40, 45, 50, 55, 60, 65, 70, 75, 80, 85, 90, or 95 percent different (e.g., higher or lower) than the value for the same parameter when processing an identical feed stream without r-pyoil, ceteris paribus. The percentage is calculated according to the following formula:

$$\frac{[(\text{measured value for operating parameter}) - (\text{target value for operating parameter})]}{[(\text{target value for operating parameter})]}, \text{ expressed as a percentage.}$$

[0366] One example of an operating parameter that may be adjusted with the addition of r-pyoil to a cracker stream is coil outlet temperature. For example, in an embodiment or in combination with any embodiment mentioned herein, the cracking furnace may be operated to achieve a first coil outlet temperature (COT1) when a cracker stream having no r-pyoil is present. Next, r-pyoil may be added to the cracker stream, via any of the methods mentioned herein, and the combined stream may be cracked to achieve a second coil outlet temperature (COT2) that is different than COT1.

[0367] In some cases, when the r-pyoil is heavier than the cracker stream, COT2 may be less than COT1, while, in other case, when the r-pyoil is lighter than the cracker stream, COT2 may be greater than or equal to COT1. When the r-pyoil is lighter than the cracker stream, it may have a 50% boiling point that is at least 5, 10, 15, 20, 25, 30, 35, 40, 45, or 50 and/or not more than 80, 75, 70, 65, 60, 55, or 50 percent higher than the 50% boiling point of the cracker stream. The percentage is calculated according to the following formula:

$$\frac{[(50\% \text{ boiling point of r-pyoil in } ^\circ \text{R}) - (50\% \text{ boiling point of cracker stream})]}{[(50\% \text{ boiling point of cracker stream})]}, \text{ expressed as a percentage.}$$

[0368] Alternatively, or in addition, the 50% boiling point of the r-pyoil may be at least 5, 10, 15, 20, 25, 30, 35, 40, 45, 50, 55, 60, 65, 70, 75, 80, 85, 90, 95, or 100° C. and/or not more than 300, 275, 250, 225, or 200° C. lower than the 50% boiling point of the cracker stream. Heavier cracker streams can include, for example, vacuum gas oil (VGO), atmospheric gas oil (AGO), or even coker gas oil (CGO), or combinations thereof.

[0369] When the r-pyoil is lighter than the cracker stream, it may have a 50% boiling point that is at least 5, 10, 15, 20, 25, 30, 35, 40, 45, or 50 and/or not more than 80, 75, 70, 65, 60, 55, or 50 percent lower than the 50% boiling point of the cracker stream. The percentage is calculated according to the following formula:

$$\frac{[(50\% \text{ boiling point of r-pyoil}) - (50\% \text{ boiling point of cracker stream})]}{[(50\% \text{ boiling point of cracker stream})]}, \text{ expressed as a percentage.}$$

[0370] Additionally, or in the alternative, the 50% boiling point of the r-pyoil may be at least 5, 10, 15, 20, 25, 30, 35, 40, 45, 50, 55, 60, 65, 70, 75, 80, 85, 90, 95, or 100° C. and/or not more than 300, 275, 250, 225, or 200° C. higher

than the 50% boiling point of the cracker stream. Lighter cracker streams can include, for example, LPG, naphtha, kerosene, natural gasoline, straight run gasoline, and combinations thereof.

[0371] In some cases, COT1 can be at least 5, 10, 15, 20, 25, 30, 35, 40, 45, 50° C. and/or not more than about not more than 150, 140, 130, 125, 120, 110, 105, 100, 90, 80, 75, 70, or 65° C. different (higher or lower) than COT2, or COT1 can be at least 0.3, 0.6, 1, 2, 5, 10, 15, 20, or 25 and/or not more than 80, 75, 70, 65, 60, 50, 45, or 40 percent different than COT2 (with the percentage here defined as the difference between COT1 and COT2 divided by COT1, expressed as a percentage). At least one or both of COT1 and COT2 can be at least 730, 750, 77, 800, 825, 840, 850, 860, 870, 880, 890, 900, 910, 920, 930, 940, 950, 960, 970, 980, 990 and/or not more than 1200, 1175, 1150, 1140, 1130, 1120, 1110, 1100, 1090, 1080, 1070, 1060, 1050, 1040, 1030, 1020, 1010, 1000, 990, 980, 970, 960, 950, 940, 930, 920, 910, or 900° C.

[0372] In an embodiment or in combination with any of the embodiments mentioned herein, the mass velocity of the cracker feed stream through at least one, or at least two radiant coils (for clarity as determine across the entire coil as opposed to a tube within a coil) is in the range of 60 to 165 kilograms per second (kg/s) per square meter (m²) of cross-sectional area (kg/s/m²), 60 to 130 (kg/s/m²), 60 to 110 (kg/s/m²), 70 to 110 (kg/s/m²), or 80 to 100 (kg/s/m²). When steam is present, the mass velocity is based on the total flow of hydrocarbon and steam.

[0373] In one embodiment or in combination with any mentioned embodiments, there is provided a method for making one or more olefins by:

[0374] (a) cracking a cracker stream in a cracking unit at a first coil outlet temperature (COT1);

[0375] (b) subsequent to step (a), adding a stream comprising a recycle content pyrolysis oil composition (r-pyoil) to said cracker stream to form a combined cracker stream; and

[0376] (c) cracking said combined cracker stream in said cracking unit at a second coil outlet temperature (COT2), wherein said second coil outlet temperature is lower, or at least 3°C lower, or at least 5° C. lower than said first coil outlet temperature.

[0377] The reason or cause for the temperature drop in the second coil outlet temperature (COT2) is not limited, provided that COT2 is lower than the first coil outlet temperature (COT1). In one embodiment or in combination with any mentioned embodiments, In one embodiment or in combination with any other mentioned embodiments, the COT2 temperature on the r-pyoil fed coils can be set to a temperature that lower than, or at least 1, 2, 3, 4, or at least 5° C. lower than COT1 (“Set” Mode), or it can be allowed to change or float without setting the temperature on the r-pyoil fed coils (“Free Float” Mode”).

[0378] The COT2 can be set at least 5° C. lower than COT1 in a Set Mode. All coils in a furnace can be r-pyoil containing feed streams, or at least 1, or at least two of the coils can be r-pyoil containing feed streams. In either case, at least one of the r-pyoil containing coils can be in a Set Mode. By reducing the cracking severity of the combined cracking stream, one can take advantage of the lower heat energy required to crack r-pyoil when it has an average number average molecular weight that is higher than the cracker feed stream, such as a gaseous C₂-C₄ feed. While the

cracking severity on the cracker feed (e.g., C₂-C₄) can be reduced and thereby increase the amount of unconverted C₂-C₄ feed in a single pass, the higher amount of unconverted feed (e.g., C₂-C₄ feed) is desirable to increase the ultimate yield of olefins such as ethylene and/or propylene through multiple passes by recycling the unconverted C₂-C₄ feed through the furnace. Optionally, other cracker products, such as the aromatic and diene content, can be reduced.

[0379] In one embodiment or in combination with any mentioned embodiments, in one embodiment or in combination with any other mentioned embodiments, the COT2 in a coil can be fixed in a Set Mode to be lower than, or at least 1, 2, 3, 4, or at least 5° C. lower than the COT1 when the hydrocarbon mass flow rate of the combined cracker stream in at least one coil is the same as or less than the hydrocarbon mass flow rate of the cracker stream in step (a) in said coil. The hydrocarbon mass flow rate includes all hydrocarbons (cracker feed and if present the r-pyoil and/or natural gasoline or any other types of hydrocarbons) and other than steam. Fixing the COT2 is advantageous when the hydrocarbon mass flow rate of the combined cracker stream in step (b) is the same as or less than the hydrocarbon mass flow rate of the cracker stream in step (a) and the pyoil has a higher average molecular weight than the average molecular weight of the cracker stream. At the same hydrocarbon mass flow rates, when pyoil has a heavier average molecular weight than the cracker stream, the COT2 will tend to rise with the addition of pyoil because the higher molecular weight molecules require less thermal energy to crack. If one desires to avoid overcracking the pyoil, the lowered COT2 temperature can assist to reduce by-product formation, and while the olefin yield in the single pass is also reduced, the ultimate yield of olefins can be satisfactory or increased by recycling unconverted cracker feed through the furnace.

[0380] In a Set Mode, the temperature can be fixed or set by adjusting the furnace fuel rate to burners.

[0381] In one embodiment or in combination with any other mentioned embodiments, the COT2 is in a Free Float Mode and is as a result of feeding pyoil and allowing the COT2 to rise or fall without fixing a temperature to the pyoil fed coils. In this embodiment, not all of the coils contain r-pyoil. The heat energy supplied to the r-pyoil containing coils can be supplied by keeping constant temperature on, or fuel feed rate to the burners on the non-recycle cracker feed containing coils. Without fixing or setting the COT2, the COT2 can be lower than COT1 when pyoil is fed to the cracker stream to form a combined cracker stream that has a higher hydrocarbon mass flow rate than the hydrocarbon mass flow rate of the cracker stream in step (a). Pyoil added to a cracker feed to increase the hydrocarbon mass flow rate of the combined cracker feed lowers the COT2 and can outweigh the temperature rise effect of using a higher average molecular weight pyoil. These effects can be seen while other cracker conditions are held constant, such as the dilution steam ratio, feed locations, composition of the cracker feed and pyoil, and fuel feed rates to the firebox burners in the furnace on the tubes containing only cracker feed and no feed of r-pyoil.

[0382] The COT2 can be lower than, or at least 1, 2, 3, 4, 5, 8, 10, 12, 15, 18, 20, 25, 30, 35, 40, 45, 50° C. and/or not more than about not more than 150, 140, 130, 125, 120, 110, 105, 100, 90, 80, 75, 70, or 65° C. lower than COT1.

[0383] Independent of the reason or cause of the temperature drop in COT2, the time period for engaging step (a) is

flexible, but ideally, step (a) reaches a steady state before engaging step (b). In one embodiment or in combination with any mentioned embodiments, step (a) is in operation for at least 1 week, or at least 2 weeks, or at least 1 month, or at least 3 months, or at least 6 months, or at least 1 year, or at least 1.5 years, or at least 2 years. The step (a) can be represented by a cracker furnace in operation that has never accepted a feed of pyoil or a combined feed of cracker feed and pyoil. Step (b) can be the first time a furnace has accepted a feed of pyoil or a combined cracker feed containing pyoil. In one embodiment or in combination with any other mentioned embodiments, steps (a) and (b) can be cycled multiple times per year, such as at least 2x/yr, or at least 3x/yr, or at least 4x/yr, or at least 5x/yr, or at least 6x/yr, or at least 8x/yr, or at least 12x/yr, as measured on a calendar year. Campaigning a feed of pyoil is representative of multiple cycling of steps (a) and (b). When the feed supply of pyoil is exhausted or shut off, the COT1 is allowed to reach a steady state temperature before engaging step (b).

[0384] Alternatively, the feed of pyoil to a cracker feed can be continuous over the entire course of at least 1 calendar year, or at least 2 calendar years.

[0385] In one embodiment or in combination with any other mentioned embodiments, the cracker feed composition used in steps (a) and (b) remains unchanged, allowing for regular compositional variations observed during the course of a calendar year. In one embodiment or in combination with any other mentioned embodiments, the flow of cracker feed in step (a) is continuous and remains continuous as pyoil is to the cracker feed to make a combined cracker feed. The cracker feed in steps (a) and (b) can be drawn from the same source, such as the same inventory or pipeline.

[0386] In one embodiment or in combination with any mentioned embodiments, the COT2 is lower than, or at least 1, 2, 3, 4, or at least 5° C. lower for at least 30% of the time that the pyoil is fed to the cracker stream to form the combined cracker stream, or at least 40% of the time, or at least 50% of the time, or at least 60% of the time, or at least 70% of the time, or at least 80% of the time, or at least 85% of the time, or at least 90% of the time, or at least 95% of the time, the time measured as when all conditions, other than COT's, are held constant, such as cracker and pyoil feed rates, steam ratio, feed locations, composition of the cracker feed and pyoil, etc.

[0387] In one embodiment or in combination with any mentioned embodiments, the hydrocarbon mass flow rate of combined cracker feed can be increased. There is now provided a method for making one or more olefins by:

[0388] (a) cracking a cracker stream in a cracking unit at a first hydrocarbon mass flow rate (MF1);

[0389] (b) subsequent to step (a), adding a stream comprising a recycle content pyrolysis oil composition (r-pyoil) to said cracker stream to form a combined cracker stream having a second hydrocarbon mass flow rate (MF2) that is higher than MF1; and

[0390] (c) cracking said combined cracker stream at MF2 in said cracking unit to obtain an olefin-containing effluent that has a combined output of ethylene and propylene that same as or higher than the output of ethylene and propylene obtained by cracking only said cracker stream at MF1.

[0391] The output refers to the production of the target compounds in weight per unit time, for example, kg/hr. Increasing the mass flow rate of the cracker stream by

addition of r-pyoil can increase the output of combined ethylene and propylene, thereby increasing the throughput of the furnace. Without being bound to a theory, it is believed that this is made possible because the total energy of reaction is not as endothermic with the addition of pyoil relative to total energy of reaction with a lighter cracker feed such as propane or ethane. Since the heat flux on the furnace is limited and the total heat of reaction of pyoil is less endothermic, more of the limited heat energy becomes available to continue cracking the heavy feed per unit time. The MF2 can be increased by at least 1, 2, 3, 4, 5, 7, 10, 10, 13, 15, 18, or 20% through a r-pyoil fed coil, or can be increased by at least 1, 2, 3, 5, 7, 10, 10, 13, 15, 18, or 20% as measured by the furnace output provided that at least one coil processes r-pyoil. Optionally, the increase in combined output of ethylene and propylene can be accomplished without varying the heat flux in the furnace, or without varying the r-pyoil fed coil outlet temperature, or without varying the fuel feed rate to the burners assigned to heat the coils containing only non-recycle content cracker feed, or without varying the fuel feed rate to any of the burners in the furnace. The MF2 higher hydrocarbon mass flow rate in the r-pyoil containing coils can be through one or at least one coil in a furnace, or two or at least two, or 50% or at least 50%, or 75% or at least 75%, or through all of the coils in a furnace.

[0392] The olefin-containing effluent stream can have a total output of propylene and ethylene from the combined cracker stream at MF2 that is the same as or higher than the output of propylene and ethylene of an effluent stream obtained by cracking the same cracker feed but without r-pyoil by at least 0.5%, or at least 1%, or at least 2%, or at least 2.5%, determined as:

$$\% \text{ increase} = \frac{Omf2 - Omf1}{Omf1} \times 100$$

[0393] where O_{mf1} is the combined output of propylene and ethylene content in the cracker effluent at MF1 made without r-pyoil; and

[0394] O_{mf2} is the combined output of propylene and ethylene content in the cracker effluent at MF2 made with r-pyoil.

[0395] The olefin-containing effluent stream can have a total output of propylene and ethylene from the combined cracker stream at MF2 that is least 1, 5, 10, 15, 20%, and/or up to 80, 70, 65% of the mass flow rate increase between MF2 and MF1 on a percentage basis. Examples of suitable ranges include 1 to 80, or 1 to 70, or 1 to 65, or 5 to 80, or 5 to 70, or 5 to 65, or 10 to 80, or 10 to 70, or 10 to 65, or 15 to 80, or 15 to 70, or 15 to 65, or 20 to 80, or 20 to 70, or 20 to 65, or 25 to 80, or 25 to 70, or 26 to 65, or 35 to 80, or 35 to 70, or 35 to 65, or 40 to 80, or 40 to 70, or 40 to 65, each expressed as a percent %. For example, if the percentage difference between MF2 and MF1 is 5%, and the total output of propylene and ethylene is increased by 2.5%, the olefin increase as a function of mass flow increase is 50% (2.5%/5% x 100). This can be determined as:

$$\% \text{ relative increase} = \frac{\Delta O \%}{\Delta MF \%} \times 100$$

[0396] where ΔO % is percentage increase between the combined output of propylene and ethylene content in the cracker effluent at MF1 made without r-pyoil and MF2 made with r-pyoil (using the aforementioned equation); and

[0397] ΔMF % is the percentage increase of MF2 over MF1.

[0398] Optionally, the olefin-containing effluent stream can have a total wt. % of propylene and ethylene from the combined cracker stream at MF2 that is the same as or higher than the wt. % of propylene and ethylene of an effluent stream obtained by cracking the same cracker feed but without r-pyoil by at least 0.5%, or at least 1%, or at least 2%, or at least 2.5%, determined as:

$$\% \text{ increase} = \frac{Emf2 - Emf1}{Emf1} \times 100$$

[0399] where E_{mf1} is the combined wt. % of propylene and ethylene content in the cracker effluent at MF1 made without r-pyoil; and

[0400] E_{mf2} is the combined wt. % of propylene and ethylene content in the cracker effluent at MF2 made with r-pyoil.

[0401] There is also provided a method for making one or more olefins, said method comprising:

[0402] (a) cracking a cracker stream in a cracking furnace to provide a first olefin-containing effluent exiting the cracking furnace at a first coil outlet temperature (COT1);

[0403] (b) subsequent to step (a), adding a stream comprising a recycle content pyrolysis oil composition (r-pyoil) to said cracker stream to form a combined cracker stream; and

[0404] (c) cracking said combined cracker stream in said cracking unit to provide a second olefin-containing effluent exiting the cracking furnace at a second coil outlet temperature (COT2),

[0405] wherein, when said r-pyoil is heavier than said cracker stream, COT2 is equal to or less than COT1,

[0406] wherein, when said r-pyoil is lighter than said cracker stream, COT2 is greater than or equal to COT1.

[0407] In this method, the embodiments described above for a COT2 at lower than COT1 are also applicable here. The COT2 can be in a Set Mode or Free Float Mode. In one embodiment or in combination with any other mentioned embodiments, the COT2 is in a Free Float Mode and the hydrocarbon mass flow rate of the combined cracker stream in step (b) is higher than the hydrocarbon mass flow rate of the cracker stream in step (a). In one embodiment or in combination with any mentioned embodiments, the COT2 is in a Set Mode.

[0408] In one embodiment or in combination with any mentioned embodiments, there is provided a method for making one or more olefins by:

[0409] (a) cracking a cracker stream in a cracking unit at a first coil outlet temperature (COT1);

[0410] (b) subsequent to step (a), adding a stream comprising a recycle content pyrolysis oil composition (r-pyoil) to said cracker stream to form a combined cracker stream; and

[0411] (c) cracking said combined cracker stream in said cracking unit at a second coil outlet temperature

(COT2), wherein said second coil outlet temperature is higher than the first coil outlet temperature.

[0412] The COT2 can be at least 5, 8, 10, 12, 15, 18, 20, 25, 30, 35, 40, 45, 50° C. and/or not more than about not more than 150, 140, 130, 125, 120, 110, 105, 100, 90, 80, 75, 70, or 65° C. higher than COT1.

[0413] In one embodiment or in combination with any other mentioned embodiments, r-pyoil is added to the inlet of at least one coil, or at least two coils, or at least 50%, or at least 75%, or all of the coils, to form at least one combined cracker stream, or at least two combined cracker streams, or at least the same number of combined cracker streams as coils accepting a feed of r-pyoil. At least one, or at least two of the combined cracker streams, or at least all of the r-pyoil fed coils can have a COT2 that is higher than their respective COT1. In one embodiment or in combination with any mentioned embodiments, at least one, or at least two coils, or at least 50%, or at least 75% of the coils within said cracking furnace contain only non-recycle content cracker feed, with at least one of the coils in the cracking furnace being fed with r-pyoil, and the coil or at least some of multiple coils fed with r-pyoil having a COT2 higher than their respective COT1.

[0414] In one embodiment or in combination with any mentioned embodiments, the hydrocarbon mass flow rate of the combined stream in step (b) is substantially the same as or lower than the hydrocarbon mass flow rate of the cracker stream in step (a). By substantially the same is meant not more than a 2% difference, or not more than a 1% difference, or not more than a 0.25% difference. When the hydrocarbon mass flow rate of the combined cracker stream in step (b) is substantially the same as or lower than the hydrocarbon mass flow rate of the cracker stream (a), and the COT2 is allowed to operate in a Free Float Mode (where at least 1 of the tubes contains non-recycle content cracker stream), the COT2 on the r-pyoil containing coil can rise relative to COT1. This is the case even though the pyoil, having a larger number average molecular weight compared to the cracker stream, requires less energy to crack. Without being bound to a theory, it is believed that one or a combination of factors contribute to the temperature rise, including the following:

[0415] a. Lower heat energy is required to crack pyoil in the combined stream; or

[0416] b. The occurrence of exothermic reactions among cracked products of pyoil, such as diels-alder reactions.

[0417] This effect can be seen when the other process variables are constant, such as the firebox fuel rate, dilution steam ratio, location of feeds, and composition of the cracker feed.

[0418] In one embodiment or in combination with any mentioned embodiments, the COT2 can be set or fixed to a higher temperature than COT1 (the Set Mode). This is more applicable when the hydrocarbon mass flow rate of the combined cracker stream is higher than the hydrocarbon mass flow rate of the cracker stream which would otherwise lower the COT2. The higher second coil outlet temperature (COT2) can contribute to an increased severity and a decreased output of unconverted lighter cracker feed (e.g., C₂-C₄ feed), which can assist with downstream capacity restricted fractionation columns.

[0419] In one embodiment or in combination with any mentioned embodiments, whether the COT2 is higher or lower than COT1, the cracker feed compositions are the

same when a comparison is made between COT2 with a COT1. Desirably, the cracker feed composition in step (a) is the same cracker composition as used to make the combined cracker stream in step (b). Optionally, the cracker composition feed in step (a) is continuously fed to the cracker unit, and the addition of pyoil in step (b) is to the continuous cracker feed in step (a). Optionally, the feed of pyoil to the cracker feed is continuous for at least 1 day, or at least 2 days, or at least 3 days, or at least 1 week, or at least 2 weeks, or at least 1 month, or at least 3 months, or at least 6 months or at least 1 year.

[0420] The amount of raising or lowering the cracker feed in step (b) in any of the mentioned embodiments can be at least 2%, or at least 5%, or at least 8%, or at least 10%. In one embodiment or in combination with any mentioned embodiments, the amount of lowering the cracker feed in step (b) can be an amount that corresponds to the addition of pyoil by weight. In one embodiment or in combination with any mentioned embodiments, the mass flow of the combined cracker feed is at least 1%, or at least 5%, or at least 8%, or at least 10% higher than the hydrocarbon mass flow rate of the cracker feed in step (a).

[0421] In any or all of the mentioned embodiments, the cracker feed or combined cracker feed mass flows and COT relationships and measurements are satisfied if any one coil in the furnace satisfies the stated relationships but can also be present in multiple tubes depending on how the pyoil is fed and distributed.

[0422] In an embodiment or in combination with any of the embodiments mentioned herein, the burners in the radiant zone provide an average heat flux into the coil in the range of from 60 to 160 kW/m² or 70 to 145 kW/m² or 75 to 130 kW/m². The maximum (hottest) coil surface temperature is in the range of 1035 to 1150° C. or 1060 to 1180° C. The pressure at the inlet of the furnace coil in the radiant section is in the range of 1.5 to 8 bar absolute (bara), or 2.5 to 7 bara, while the outlet pressure of the furnace coil in the radiant section is in the range of from 1.03 to 2.75 bara, or 1.03 to 2.06 bara. The pressure drop across the furnace coil in the radiant section can be from 1.5 to 5 bara, or 1.75 to 3.5 bara, or 1.5 to 3 bara, or 1.5 to 3.5 bara.

[0423] In an embodiment or in combination with any of the embodiments mentioned herein, the yield of olefin—ethylene, propylene, butadiene, or combinations thereof—can be at least 15, or at least 20, or at least 25, or at least 30, or at least 35, or at least 40, or at least 45, or at least 50, or at least 55, or at least 60, or at least 65, or at least 70, or at least 75, or at least 80, in each case percent. As used herein, the term “yield” refers to the mass of product/mass of feedstock x 100%. The olefin-containing effluent stream comprises at least about 30, or at least 40, or at least 50, or at least 60, or at least 70, or at least 75, or at least 80, or at least 85, or at least 90, or at least 95, or at least 97, or at least 99, in each case weight percent of ethylene, propylene, or ethylene and propylene, based on the total weight of the effluent stream.

[0424] In an embodiment or in combination with one or more embodiments mentioned herein, the olefin-containing effluent stream **670** can comprise C₂ to C₄ olefins, or propylene, or ethylene, or C₄ olefins, in an amount of at least 5, 10, 15, 20, 25, 30, 35, 40, 45, 50, 55, 60, 65, 70, 75, 80, 85, or 90 weight percent, based on the weight of the olefin-containing effluent. The stream may comprise predominantly ethylene, predominantly propylene, or predominantly

ethylene and propylene, based on the olefins in the olefin-containing effluent, or based on the weight of the C₁-C₅ hydrocarbons in the olefin-containing effluent, or based on the weight of the olefin-containing effluent stream. The weight ratio of ethylene-to-propylene in the olefin-containing effluent stream can be at least about 0.2:1, 0.3:1, 0.4:1, 0.5:1, 0.6:1, 0.7:1, 0.8:1, 0.9:1, 1:1, 1.1:1, 1.2:1, 1.3:1, 1.4:1, 1.5:1, 1.6:1, 1.7:1, 1.8:1, 1.9:1, or 2:1 and/or not more than 3:1, 2.9:1, 2.8:1, 2.7:1, 2.5:1, 2.3:1, 2.2:1, 2.1:1, 2:1, 1.7:1, 1.5:1, or 1.25:1. In an embodiment or in combination with one or more embodiments mentioned herein, the olefin-containing effluent stream can have a ratio of propylene:ethylene that is higher than the propylene:ethylene ratio of an effluent stream obtained by cracking the same cracker feed but without r-pyoil at equivalent dilution steam ratios, feed locations, cracker feed compositions (other than the r-pyoil), and allowing the coils fed with r-pyoil to be in the Float Mode, or if all coils in a furnace are fed with r-pyoil, then at the same temperature prior to feeding r-pyoil. As discussed above, this is possible when the mass flow of the cracker feed remains substantially the same resulting in a higher hydrocarbon mass flow rate of the combined cracker stream when r-pyoil is added relative to the original feed of the cracker stream.

[0425] The olefin-containing effluent stream can have a ratio of propylene:ethylene that is at least 1% higher, or at least 2% higher, or at least 3% higher, or at least 4% higher, or at least 5% higher or at least 7% higher or at least 10% higher or at least 12% higher or at least 15% higher or at least 17% higher or at least 20% higher than the propylene:ethylene ratio of an effluent stream obtained by cracking the same cracker feed but without r-pyoil. Alternatively or in addition, the olefin-containing effluent stream can have a ratio of propylene:ethylene that is up to 50% higher, or up to 45% higher, or up to 40% higher, or up to 35% higher, or up to 25% higher, or up to 20% higher than the propylene:ethylene ratio of an effluent stream obtained by cracking the same cracker feed but without r-pyoil, in each case determined as:

$$\% \text{ increase} = \frac{Er - E}{E} \times 100$$

[0426] where E is the propylene:ethylene ratio by wt. % in the cracker effluent made without r-pyoil; and

[0427] E_r is the propylene:ethylene ratio by wt. % in the cracker effluent made with r-pyoil.

[0428] In an embodiment or in combination with any of the embodiments mentioned herein, the amount of ethylene and propylene can remain substantially unchanged or increased in the cracked olefin-containing effluent stream relative to an effluent stream without r-pyoil. It is surprising that a liquid r-pyoil can be fed to a gas fed furnace that accepts and cracks a predominant C₂-C₄ composition and obtain an olefin-containing effluent stream that can remain substantially unchanged or improved in certain cases relative to a C₂-C₄ cracker feed without r-pyoil. The heavy molecular weight of r-pyoil could have predominately contributed to the formation of aromatics and participate in the formation of olefins (ethylene and propylene in particular) in only a minor amount. However, we have found that the combined weight percent of ethylene and propylene, and even the output, does not significantly drop, and in many

cases stays the same or can increase when r-pyoil is added to a cracker feed to form a combined cracker feed at the same hydrocarbon mass flow rates relative to a cracker feed without r-pyoil. The olefin-containing effluent stream can have a total wt. % of propylene and ethylene that is the same as or higher than the propylene and ethylene content of an effluent stream obtained by cracking the same cracker feed but without r-pyoil by at least 0.5%, or at least 1%, or at least 2%, or at least 2.5%, determined as:

$$\% \text{ increase} = \frac{Er - E}{E} \times 100$$

[0429] where E is the combined wt. % of propylene and ethylene content in the cracker effluent made without r-pyoil; and

[0430] E_r is the combined wt. % of propylene and ethylene content in the cracker effluent made with r-pyoil.

[0431] In an embodiment or in combination with one or more embodiments mentioned herein, the wt % of propylene can improve in an olefin-containing effluent stream when the dilution steam ratio (ratio of steam:hydrocarbons by weight) is above 0.3, or above 0.35, or at least 0.4. The increase in the wt. % of propylene when the dilution steam ratio is at least 0.3, or at least 0.35, or at least 0.4 can be up to 0.25 wt. %, or up to 0.4 wt. %, or up to 0.5 wt. %, or up to 0.7 wt. %, or up to 1 wt. %, or up to 1.5 wt. %, or up to 2 wt. %, where the increase is measured as the simple difference between the wt. % of propylene between an olefin-containing effluent stream made with r-pyoil at a dilution steam ratio of 0.2 and an olefin-containing effluent stream made with r-pyoil at a dilution steam ratio of at least 0.3, all other conditions being the same.

[0432] When the dilution steam ratio is increased as noted above, the ratio of propylene:ethylene can also increase, or can be at least 1% higher, or at least 2% higher, or at least 3% higher, or at least 4% higher, or at least 5% higher or at least 7% higher or at least 10% higher or at least 12% higher or at least 15% higher or at least 17% higher or at least 20% higher than the propylene:ethylene ratio of an olefin-containing effluent stream made with r-pyoil at a dilution steam ratio of 0.2.

[0433] In an embodiment or in combination with one or more embodiments mentioned herein, when the dilution steam ratio is increased, the olefin-containing effluent stream can have a reduced wt. % of methane, when measured relative to an olefin-containing effluent stream at a dilution steam ratio of 0.2. The wt. % of methane in the olefin-containing effluent stream can be reduced by at least 0.25 wt. %, or by at least 0.5 wt. %, or by at least 0.75 wt. %, or by at least 1 wt. %, or by at least 1.25 wt. %, or by at least 1.5 wt. %, measured as the absolute value difference in wt. % between the olefin-containing effluent stream at a dilution steam ratio of 0.2 and at the higher dilution steam ratio value.

[0434] In an embodiment or in combination with one or more embodiments mentioned herein, the amount of unconverted products in the olefin-containing effluent is decreased, when measured relative to a cracker feed that does not contain r-pyoil and all other conditions being the same, including hydrocarbon mass flow rate. For example, the amount of propane and/or ethane can be decreased by

addition of r-pyoil. This can be advantageous to decrease the mass flow of the recycle loop to thereby (a) decrease cryogenic energy costs and/or (b) potentially increase capacity on the plant if the plant is already capacity constrained. Further it can debottleneck the propylene fractionator if it is already to its capacity limit. The amount of unconverted products in the olefin containing effluent can decrease by at least 2%, or at least 5%, or at least 8%, or at least 10%, or at least 13%, or at least 15%, or at least 18%, or at least 20%.

[0435] In an embodiment or in combination with one or more embodiments mentioned herein, the amount of unconverted products (e.g., combined propane and ethane amount) in the olefin-containing effluent is decreased while the combined output of ethylene and propylene does not drop and is even improved, when measured relative to a cracker feed that does not contain r-pyoil. Optionally, all other conditions are the same including the hydrocarbon mass flow rate and with respect to temperature, where the fuel feed rate to heat the burners to the non-recycle content cracker fed coils remains unchanged, or optionally when the fuel feed rate to all coils in the furnace remains unchanged. Alternatively, the same relationship can hold true on a wt. % basis rather than an output basis.

[0436] For example, the combined amount (either or both of output or wt. %) of propane and ethane in the olefin containing effluent can decrease by at least 2%, or at least 5%, or at least 8%, or at least 10%, or at least 13%, or at least 15%, or at least 18%, or at least 20%, and in each case up to 40% or up to 35% or up to 30%, in each case without a decrease in the combined amount of ethylene and propylene, and even can accompany an increase in the combined amount of ethylene and propylene. In another example, the amount of propane in the olefin containing effluent can decrease by at least 2%, or at least 5%, or at least 8%, or at least 10%, or at least 13%, or at least 15%, or at least 18%, or at least 20%, and in each case up to 40% or up to 35% or up to 30%, in each case without a decrease in the combined amount of ethylene and propylene, and even can accompany an increase in the combined amount of ethylene and propylene. In any one of these embodiments, the cracker feed (other than r-pyoil and as fed to the inlet of the convection zone) can be predominately propane by moles, or at least 90 mole % propane, or at least 95 mole % propane, or at least 96 mole % propane, or at least 98 mole % propane; or the fresh supply of cracker feed can be at least HD5 quality propane.

[0437] In an embodiment or in combination with one or more embodiments mentioned herein, the ratio of propane:(ethylene and propylene) in the olefin-containing effluent can decrease with the addition of r-pyoil to the cracker feed when measured relative to the same cracker feed without pyoil and all other conditions being the same, measured either as wt. % or output. The ratio of propane:(ethylene and propylene combined) in the olefin-containing effluent can be not more than 0.50:1, or less than 0.50:1, or not more than 0.48:1, or not more than 0.46:1, or no more than 0.43:1, or no more than 0.40:1, or no more than 0.38:1, or no more than 0.35:1, or no more than 0.33:1, or no more than 0.30:1. The low ratios indicate that a high amount of ethylene+propylene can be achieved or maintained with a corresponding drop in unconverted products such as propane.

[0438] In an embodiment or in combination with one or more embodiments mentioned herein, the amount of C₆+ products in the olefin-containing effluent can be increased, if

such products are desired such as for a BTX stream to make derivatives thereof, when r-pyoil and steam are fed downstream of the inlet to the convection box, or when one or both of r-pyoil and steam are fed at the cross-over location. The amount of C₆+ products in the olefin-containing effluent can be increased by 5%, or by 10%, or by 15%, or by 20%, or by 30% when r-pyoil and steam are fed downstream of the inlet to the convection box, when measured against feeding r-pyoil at the inlet to the convection box, all other conditions being the same. The % increase can be calculated as:

$$\% \text{ increase} = \frac{E_i - E_d}{E_i} \times 100$$

[0439] where

[0440] E_i is the C₆+ content in the olefin-containing cracker effluent made by introducing r-pyoil at the inlet of the convection box; and

[0441] E_d is the C₆+ content in the olefin-containing cracker effluent made by introducing r-pyoil and steam downstream of the inlet of the convection box.

[0442] In an embodiment or in combination with any of the embodiments mentioned herein, the cracked olefin-containing effluent stream may include relatively minor amounts of aromatics and other heavy components. For example, the olefin-containing effluent stream may include at least 0.5, 1, 2, or 2.5 weight percent and/or not more than about 20, 19, 18, 17, 16, 15, 14, 13, 12, 11, 10, 9, 8, 7, 6, 5, 4, 3, 2, or 1 weight percent of aromatics, based on the total weight of the stream. We have found that the level of C₆+ species in the olefin-containing effluent can be not more than 5 wt. %, or not more than 4 wt. %, or not more than 3.5 wt. %, or not more than 3 wt. %, or not more than 2.8 wt. %, or not more than 2.5 wt. %. The C₆+ species includes all aromatics, as well as all paraffins and cyclic compounds having a carbon number of 6 or more. As used throughout, the mention of amounts of aromatics can be represented by amounts of C₆+ species since the amount of aromatics would not exceed the amount of C₆+ species.

[0443] The olefin-containing effluent may have an olefin-to-aromatic ratio, by weight %, of at least 2:1, 3:1, 4:1, 5:1, 6:1, 7:1, 8:1, 9:1, 10:1, 11:1, 12:1, 13:1, 14:1, 15:1, 16:1, 17:1, 18:1, 19:1, 20:1, 21:1, 22:1, 23:1, 24:1, 25:1, 26:1, 27:1, 28:1, 29:1, or 30:1 and/or not more than 100:1, 90:1, 85:1, 80:1, 75:1, 70:1, 65:1, 60:1, 55:1, 50:1, 45:1, 40:1, 35:1, 30:1, 25:1, 20:1, 15:1, 10:1, or 5:1. As used herein, "olefin-to-aromatic ratio" is the ratio of total weight of C₂ and C₃ olefins to the total weight of aromatics, as defined previously. In an embodiment or in combination with any of the embodiments mentioned herein, the effluent stream can have an olefin-to-aromatic ratio of at least 2.5:1, 2.75:1, 3.5:1, 4.5:1, 5.5:1, 6.5:1, 7.5:1, 8.5:1, 9.5:1, 10.5:1, 11.5:1, 12.5:1, or 13.5:1.

[0444] The olefin-containing effluent may have an olefin:C₆+ ratio, by weight %, of at least 8.5:1, or at least 9.5:1, or at least 10:1, or at least 10.5:1, or at least 12:1, or at least 13:1, or at least 15:1, or at least 17:1, or at least 19:1, or at least 20:1, or at least 25:1, or at least 28:1, or at least 30:1. In addition or in the alternative, the olefin-containing effluent may have an olefin:C₆+ ratio of up to 40:1, or up to 35:1, or up to 30:1, or up to 25:1, or up to 23:1. As used herein,

“olefin-to-aromatic ratio” is the ratio of total weight of C₂ and C₃ olefins to the total weight of aromatics, as defined previously.

[0445] Additionally, or in the alternative, the olefin-containing effluent stream can have an olefin-to-C₆+ ratio of at least about 1.5:1, 1.75:1, 2:1, 2.25:1, 2.5:1, 2.75:1, 3:1, 3.25:1, 3.5:1, 3.75:1, 4:1, 4.25:1, 4.5:1, 4.75:1, 5:1, 5.25:1, 5.5:1, 5.75:1, 6:1, 6.25:1, 6.5:1, 6.75:1, 7:1, 7.25:1, 7.5:1, 7.75:1, 8:1, 8.25:1, 8.5:1, 8.75:1, 9:1, 9.5:1, 10:1, 10.5:1, 12:1, 13:1, 15:1, 17:1, 19:1, 20:1, 25:1, 28:1, or 30:1.

[0446] In an embodiment or in combination with any of the embodiments mentioned herein, the olefin:aromatic ratio decreases with an increase in the amount of r-pyoil added to the cracker feed. Since r-pyoil cracks at a lower temperature, it will crack earlier than propane or ethane, and therefore has more time to react to make other products such as aromatics. Although the aromatic content in the olefin-containing effluent increases with an increasing amount of pyoil, the amount of aromatics produced is remarkably low as noted above.

[0447] The olefin-containing composition may also include trace amounts of aromatics. For example, the composition may have a benzene content of at least 0.25, 0.3, 0.4, 0.5 weight percent and/or not more than about 2, 1.7, 1.6, 1.5 weight percent. Additionally, or in the alternative, the composition may have a toluene content of at least 0.005, 0.010, 0.015, or 0.020 and/or not more than 0.5, 0.4, 0.3, or 0.2 weight percent. Both percentages are based on the total weight of the composition.

[0448] Alternatively, or in addition, the effluent can have a benzene content of at least 0.2, 0.3, 0.4, 0.5, or 0.55 and/or not more than about 2, 1.9, 1.8, 1.7, or 1.6 weight percent and/or a toluene content of at least 0.01, 0.05, or 0.10 and/or not more than 0.5, 0.4, 0.3, or 0.2 weight percent.

[0449] In an embodiment or in combination with any of the embodiments mentioned herein, the olefin-containing effluent withdrawn from a cracking furnace which has cracked a composition comprising r-pyoil may include an elevated amount of one or more compounds or by-products not found in olefin-containing effluent streams formed by processing conventional cracker feed. For example, the cracker effluent formed by cracking r-pyoil (r-olefin) may include elevated amounts of 1,3-butadiene, 1,3-cyclopentadiene, dicyclopentadiene, or a combination of these components. In an embodiment or in combination with any of the embodiments mentioned herein, the total amount (by weight) of these components may be at least 5, 10, 15, 20, 25, 30, 35, 40, 45, 50, 55, 60, 65, 70, 75, 80, or 85 percent higher than an identical cracker feed stream processed under the same conditions and at the same mass feed rate, but without r-pyoil. The total amount (by weight) of 1,3-butadiene may be at least 5, 10, 15, 20, 25, 30, 35, 40, 45, 50, 55, 60, 65, 70, 75, 80, or 85 percent higher than an identical cracker feed stream processed under the same conditions and at the same mass feed rate, but without r-pyoil. The total amount (by weight) of 1,3-cyclopentadiene may be at least 5, 10, 15, 20, 25, 30, 35, 40, 45, 50, 55, 60, 65, 70, 75, 80, or 85 percent higher than an identical cracker feed stream processed under the same conditions and at the same mass feed rate, but without r-pyoil. The percent difference is calculated by dividing the

difference in weight percent of one or more of the above components in the r-pyoil and conventional streams by the amount (in weight percent) of the component in the conventional stream, or:

$$\% \text{ increase} = \frac{Er - E}{E} \times 100$$

[0450] where E is the wt. % of the component in the cracker effluent made without r-pyoil; and

[0451] E_r is the wt. % of the component in the cracker effluent made with r-pyoil.

[0452] In an embodiment or in combination with any of the embodiments mentioned herein, the olefin-containing effluent stream may comprise acetylene. The amount of acetylene can be at least 2000 ppm, at least 5000 ppm, at least 8000 ppm, or at least 10,000 ppm based on the total weight of the effluent stream from the furnace. It may also be not more than 50,000 ppm, not more than 40,000 ppm, not more than 30,000 ppm, or not more than 25,000 ppm, or not more than 10,000 ppm, or not more than 6,000 ppm, or not more than 5000 ppm.

[0453] In an embodiment or in combination with any of the embodiments mentioned herein, the olefin-containing effluent stream may comprise methyl acetylene and propadiene (MAPD). The amount of MAPD may be at least 2 ppm, at least 5 ppm, at least 10 ppm, at least 20 ppm, at least 50 ppm, at least 100 ppm, at least 500 ppm, at least 1000 ppm, at least 5000 ppm, or at least 10,000 ppm, based on the total weight of the effluent stream. It may also be not more than 50,000 ppm, not more than 40,000 ppm, or not more than 30,000 ppm, or not more than 10,000 ppm, or not more than 6,000 ppm, or not more than 5,000 ppm.

[0454] In an embodiment or in combination with any of the embodiments mentioned herein, the olefin-containing effluent stream may comprise low or no amounts of carbon dioxide. The olefin-containing effluent stream can have an amount, in wt. %, of carbon dioxide that is not more than the amount of carbon dioxide in an effluent stream obtained by cracking the same cracker feed but without r-pyoil at equivalent conditions, or an amount this is not higher than 5%, or not higher than 2% of the amount of carbon dioxide, in wt. %, or the same amount as a comparative effluent stream without r-pyoil. Alternatively or in addition, the olefin-containing effluent stream can have an amount of carbon dioxide that is not more than 1000 ppm, or not more than 500 ppm, or not more than 100 ppm, or not more than 80 ppm, or not more than 50 ppm, or not more than 25 ppm, or not more than 10 ppm, or not more than 5 ppm.

[0455] Turning now to FIG. 9, a block diagram illustrating the main elements of the furnace effluent treatment section are shown.

[0456] As shown in FIG. 9, the olefin-containing effluent stream from the cracking furnace 700, which includes recycle content) is cooled rapidly (e.g., quenched) in a transfer line exchange (“TLE”) 680 as shown in FIG. 8 in order to prevent production of large amounts of undesirable by-products and to minimize fouling in downstream equipment, and also to generate steam. In an embodiment or in combination with any of the embodiments mentioned herein, the temperature of the r-composition-containing effluent from the furnace can be reduced by 35 to 485° C., 35 to 375° C., or 90 to 550° C. to a temperature of 500 to

760° C. The cooling step is performed immediately after the effluent stream leaves the furnace such as, for example, within 1 to 30, 5 to 20, or 5 to 15 milliseconds. In an embodiment or in combination with any of the embodiments mentioned herein, the quenching step is performed in a quench zone **710** via indirect heat exchange with high-pressure water or steam in a heat exchanger (sometimes called a transfer line exchanger as shown in FIG. **5** as TLE **340** and FIG. **8** as TLE **680**), while, in other embodiments, the quench step is carried out by directly contacting the effluent with a quench liquid **712** (as generally shown in FIG. **9**). The temperature of the quench liquid can be at least 65, or at least 80, or at least 90, or at least 100, in each case °C and/or not more than 210, or not more than 180, or not more than 165, or not more than 150, or not more than 135, in each case ° C. When a quench liquid is used, the contacting may occur in a quench tower and a liquid stream may be removed from the quench tower comprising gasoline and other similar boiling-range hydrocarbon components. In some cases, quench liquid may be used when the cracker feed is predominantly liquid, and a heat exchanger may be used when the cracker feed is predominantly vapor.

[0457] The resulting cooled effluent stream is then vapor liquid separated and the vapor is compressed in a compression zone **720**, such as in a gas compressor having, for example, between 1 and 5 compression stages with optional inter-stage cooling and liquid removal. The pressure of the gas stream at the outlet of the first set of compression stages is in the range of from 7 to 20 bar gauge (barg), 8.5 to 18 psig (0.6~1.3 barg), or 9.5 to 14 barg.

[0458] The resulting compressed stream is then treated in an acid gas removal zone **722** for removal of acid gases, including CO, CO₂, and H₂S by contact with an acid gas removal agent. Examples of acid gas removal agents can include, but are not limited to, caustic and various types of amines. In an embodiment or in combination with any of the embodiments mentioned herein, a single contactor may be used, while, in other embodiments, a dual column absorber-stripper configuration may be employed.

[0459] The treated compressed olefin-containing stream may then be further compressed in another compression zone **724** via a compressor, optionally with inter-stage cooling and liquid separation. The resulting compressed stream, which has a pressure in the range of 20 to 50 barg, 25 to 45 barg, or 30 to 40 barg. Any suitable moisture removal method can be used including, for example, molecular sieves or other similar process to dry the gas in a drying zone **726**. The resulting stream **730** may then be passed to the fractionation section, wherein the olefins and other components may be separated in to various high-purity product or intermediate streams.

[0460] Turning now to FIG. **10**, a schematic depiction of the main steps of the fractionation section is provided. In an embodiment or in combination with any of the embodiments mentioned herein, the initial column of the fractionation train may not be a demethanizer **810**, but may be a deethanizer **820**, a depropanizer **840**, or any other type of column. As used herein, the term “demethanizer,” refers to a column whose light key is methane. Similarly, “deethanizer,” and “depropanizer,” refer to columns with ethane and propane as the light key component, respectively.

[0461] As shown in FIG. **10**, a feed stream **870** from the quench section may introduced into a demethanizer (or other) column **810**, wherein the methane and lighter (CO,

CO₂, H₂) components **812** are separated from the ethane and heavier components **814**. The demethanizer is operated at a temperature of at least -145, or at least -142, or at least -140, or at least -135, in each case ° C. and/or not more than -120, -125, -130, -135° C. The bottoms stream **814** from the demethanizer column, which includes at least 50, or at least 55, or at least 60, or at least 65, or at least 70, or at least 75, or at least 80, or at least 85, or at least 90, or at least 95 or at least 99, in each case percent of the total amount of ethane and heavier components introduced into the column, is then introduced into a deethanizer column **820**, wherein the C₂ and lighter components **816** are separated from the C₃ and heavier components **818** by fractional distillation. The de-ethanizer **820** can be operated with an overhead temperature of at least -35, or at least -30, or at least -25, or at least -20, in each case ° C. and/or not more than -5, -10, -10, -20° ° C., and an overhead pressure of at least 3, or at least 5, or at least 7, or at least 8, or at least 10, in each case barg and/or not more than 20, or not more than 18, or not more than 17, or not more than 15, or not more than 14, or not more than 13, in each case barg. The deethanizer column **820** recovers at least 60, or at least 65, or at least 70, or at least 75, or at least 80, or at least 85, or at least 90, or at least 95, or at least 97, or at least 99, in each case percent of the total amount of C₂ and lighter components introduced into the column in the overhead stream. In an embodiment or in combination with any of the embodiments mentioned herein, the overhead stream **816** removed from the deethanizer column comprises at least 50, or at least 55, or at least 60, or at least 65, or at least 70, or at least 75, or at least 80, or at least 85, or at least 90, or at least 95, in each case weight percent of ethane and ethylene, based on the total weight of the overhead stream.

[0462] As shown in FIG. **10**, the C₂ and lighter overhead stream **816** from the deethanizer **820** is further separated in an ethane-ethylene fractionator column (ethylene fractionator) **830**. In the ethane-ethylene fractionator column **830**, an ethylene and lighter component stream **822** can be withdrawn from the overhead of the column **830** or as a side stream from the top ½ of the column, while the ethane and any residual heavier components are removed in the bottoms stream **824**. The ethylene fractionator **830** may be operated at an overhead temperature of at least -45, or at least -40, or at least -35, or at least -30, or at least -25, or at least -20, in each case °C and/or not more than -15, or not more than -20, or not more than -25, in each case °C, and an overhead pressure of at least 10, or at least 12, or at least 15, in each case barg and/or not more than 25, 22, 20 barg. The overhead stream **822**, which is enriched in ethylene, can include at least 70, or at least 75, or at least 80, or at least 85, or at least 90, or at least 95, or at least 97, or at least 98, or at least 99, in each case weight percent ethylene, based on the total weight of the stream and may be sent to downstream processing unit for further processing, storage, or sale. The overhead ethylene stream **822** produced during the cracking of a cracker feedstock containing r-pyoil is a r-ethylene composition or stream. In an embodiment or in combination with any of the embodiments mentioned herein, the r-ethylene stream may be used to make one or more petrochemicals.

[0463] The bottoms stream from the ethane-ethylene fractionator **824** may include at least 40, or at least 45, or at least 50, or at least 55, or at least 60, or at least 65, or at least 70, or at least 75, or at least 80, or at least 85, or at least 90, or

at least 95, or at least 98, in each case weight percent ethane, based on the total weight of the bottoms stream. All or a portion of the recovered ethane may be recycled to the cracker furnace as additional feedstock, alone or in combination with the r-pyoil containing feed stream, as discussed previously.

[0464] The liquid bottoms stream **818** withdrawn from the deethanizer column, which may be enriched in C3 and heavier components, may be separated in a depropanizer **840**, as shown in FIG. 10. In the depropanizer **840**, C3 and lighter components are removed as an overhead vapor stream **826**, while C4 and heavier components may exit the column in the liquid bottoms **828**. The depropanizer **840** can be operated with an overhead temperature of at least 20, or at least 35, or at least 40, in each case ° C. and/or not more than 70, 65, 60, 55° C., and an overhead pressure of at least 10, or at least 12, or at least 15, in each case barg and/or not more than 20, or not more than 17, or not more than 15, in each case barg. The depropanizer column **840** recovers at least 60, or at least 65, or at least 70, or at least 75, or at least 80, or at least 85, or at least 90, or at least 95, or at least 97, or at least 99, in each case percent of the total amount of C3 and lighter components introduced into the column in the overhead stream **826**. In an embodiment or in combination with any of the embodiments mentioned herein, the overhead stream **826** removed from the depropanizer column **840** comprises at least or at least 50, or at least 55, or at least 60, or at least 65, or at least 70, or at least 75, or at least 80, or at least 85, or at least 90, or at least 95, or at least 98, in each case weight percent of propane and propylene, based on the total weight of the overhead stream **826**.

[0465] The overhead stream **826** from the depropanizer **840** are introduced into a propane-propylene fractionator (propylene fractionator) **860**, wherein the propylene and any lighter components are removed in the overhead stream **832**, while the propane and any heavier components exit the column in the bottoms stream **834**. The propylene fractionator **860** may be operated at an overhead temperature of at least 20, or at least 25, or at least 30, or at least 35, in each case °C and/or not more than 55, 50, 45, 40° ° C., and an overhead pressure of at least 12, or at least 15, or at least 17, or at least 20, in each case barg and/or not more than 20, or not more than 17, or not more than 15, or not more than 12, in each case barg. The overhead stream **860**, which is enriched in propylene, can include at least 70, or at least 75, or at least 80, or at least 85, or at least 90, or at least 95, or at least 97, or at least 98, or at least 99, in each case weight percent propylene, based on the total weight of the stream and may be sent to downstream processing unit for further processing, storage, or sale. The overhead propylene stream produced during the cracking of a cracker feedstock containing r-pyoil is a r-propylene composition or stream. In an embodiment or in combination with any of the embodiments mentioned herein, the stream may be used to make one or more petrochemicals.

[0466] The bottoms stream **834** from the propane-propylene fractionator **860** may include at least 40, or at least 45, or at least 50, or at least 55, or at least 60, or at least 65, or at least 70, or at least 75, or at least 80, or at least 85, or at least 90, or at least 95, or at least 98, in each case weight percent propane, based on the total weight of the bottoms stream **834**. All or a portion of the recovered propane may

be recycled to the cracker furnace as additional feedstock, alone or in combination with r-pyoil, as discussed previously.

[0467] Referring again to FIG. 10, the bottoms stream **828** from the depropanizer column **840** may be sent to a debutanizer column **850** for separating C4 components, including butenes, butanes and butadienes, from C5+ components. The debutanizer can be operated with an overhead temperature of at least 20, or at least 25, or at least 30, or at least 35, or at least 40, in each case ° C. and/or not more than 60, or not more than 65, or not more than 60, or not more than 55, or not more than 50, in each case ° C. and an overhead pressure of at least 2, or at least 3, or at least 4, or at least 5, in each case barg and/or not more than 8, or not more than 6, or not more than 4, or not more than 2, in each case barg. The debutanizer column recovers at least 60, or at least 65, or at least 70, or at least 75, or at least 80, or at least 85, or at least 90, or at least 95, or at least 97, or at least 99, in each case percent of the total amount of C4 and lighter components introduced into the column in the overhead stream **836**. In an embodiment or in combination with any of the embodiments mentioned herein, the overhead stream **836** removed from the debutanizer column comprises at least 30, or at least 35, or at least 40, or at least 45, or at least 50, or at least 55, or at least 60, or at least 65, or at least 70, or at least 75, or at least 80, or at least 85, or at least 90, or at least 95, in each case weight percent of butadiene, based on the total weight of the overhead stream. The overhead stream **836** produced during the cracking of a cracker feedstock containing r-pyoil is a r-butadiene composition or stream. The bottoms stream **838** from the debutanizer includes mainly C5 and heavier components, in an amount of at least 50, or at least 60, or at least 70, or at least 80, or at least 90, or at least 95 weight percent, based on the total weight of the stream. The debutanizer bottoms stream **838** may be sent for further separation, processing, storage, sale or use.

[0468] The overhead stream **836** from the debutanizer, or the C4s, can be subjected to any conventional separation methods such as extraction or distillation processes to recover a more concentrated stream of butadiene.

EXAMPLES

r-Pyoil Examples 1-4

[0469] Table 1 shows the composition of r-pyoil samples by gas chromatography. The r-pyoil samples produced the material from waste high and low density polyethylene, polypropylene, and polystyrene. Sample 4 was a lab-distilled sample in which hydrocarbons greater than C21 were removed. The boiling point curves of these materials are shown in FIGS. 13-16.

TABLE 1

Components	r-Pyoil Feed Examples			
	1	2	3	4
Propene	0.00	0.00	0.00	0.00
Propane	0.00	0.19	0.20	0.00
1,3-Butadiene	0.00	0.93	0.99	0.31
Pentene	0.16	0.37	0.39	0.32
Pentane	1.81	3.21	3.34	3.05

TABLE 1-continued

Gas Chromatography Analysis of r-Pyoil Examples				
Components	r-Pyoil Feed Examples			
	1	2	3	4
1,3-cyclopentadiene	0.00	0.00	0.00	0.00
2-methyl-Pentene	1.53	2.11	2.16	2.25
2-methyl-Pentane	2.04	2.44	2.48	3.03
Hexane	1.37	1.80	1.83	2.10
2-methyl-1,3-cyclopentadiene	0.00	0.00	0.00	0.00
1-methyl-1,3-cyclopentadiene	0.00	0.00	0.00	0.00
2,4 dimethylpentene	0.32	0.18	0.18	0.14
Benzene	0.00	0.16	0.16	0.00
5-methyl-1,3-cyclopentadiene	0.00	0.17	0.17	0.20
Heptene	1.08	1.15	1.15	1.55
Heptane	2.51	0.17	2.89	3.61
Toluene	0.58	1.05	1.09	0.84
4-methylheptane	1.50	1.67	1.68	1.99
Octene	1.37	1.35	1.37	1.88
Octane	2.56	2.72	2.78	3.40
2,4-dimethylheptene	1.25	1.54	1.55	1.60
2,4-dimethylheptane	5.08	4.01	4.05	6.40
Ethylbenzene	1.85	3.10	3.12	2.52
m,p-xylene	0.73	0.69	0.24	0.90
Styrene	0.40	0.13	1.13	0.53
o-xylene	0.12	0.36	0.00	0.00
Nonane	2.66	2.81	2.84	3.47
Nonene	1.12	0.00	0.00	1.65
MW140	2.00	1.76	1.75	2.50
Cumene	0.56	0.96	0.97	0.73
Decene/methylstyrene	1.29	1.17	1.18	1.60
Decane	3.14	3.23	3.25	3.90
Unknown 1	0.68	0.71	0.72	0.80
Indene	0.18	0.20	0.21	0.22
Indane	0.23	0.34	0.26	0.26
C11 Alkene	1.50	1.32	1.33	1.77
C11 Alkane	3.30	3.30	3.33	3.88
C12 Alkene	1.49	1.30	0.00	0.09
Naphthalene	0.10	0.12	3.24	3.73
C12 Alkane	3.34	3.21	1.31	1.66
C13 Alkane	3.20	2.90	2.97	3.40
C13 Alkene	1.46	1.20	1.17	1.53
2-methylnaphthalene	0.86	0.63	0.64	0.85
C14 Alkene	1.07	0.84	0.84	1.04
C14 Alkane	3.34	3.04	3.05	3.24
Acenaphthene	0.31	0.28	0.28	0.28
C15 Alkene	1.16	0.87	0.87	0.96
C15 Alkane	3.41	3.00	3.02	2.84
C16 Alkene	0.85	0.58	0.58	0.56
C16 Alkane	3.25	2.67	2.68	2.12
C17 Alkene	0.70	0.46	0.46	0.35
C17 Alkane	3.04	2.43	2.44	1.50
C18 Alkene	0.51	0.33	0.33	0.19
C18 Alkane	2.71	2.11	2.13	0.99
C19 Alkane	2.39	1.82	0.38	0.15
C19 Alkene	0.60	0.38	1.83	0.61
C20 Alkene	0.42	0.18	0.26	0.00
C20 Alkane	2.05	1.55	1.55	0.37
C21 Alkene	0.31	0.00	0.00	0.00
C21 Alkane	1.72	1.45	1.30	0.23
C22 Alkene	0.00	0.00	0.00	0.00
C22 Alkane	1.43	1.11	1.12	0.00
C23 Alkene	0.00	0.00	0.00	0.00
C23 Alkane	1.09	0.87	0.88	0.00
C24 Alkene	0.00	0.00	0.00	0.00
C24 Alkane	0.82	0.72	0.72	0.00
C25 Alkene	0.00	0.00	0.00	0.00
C25 Alkane	0.61	0.58	0.56	0.00
C26 Alkene	0.00	0.00	0.00	0.00
C26 Alkane	0.44	0.47	0.44	0.00
C27 Alkane	0.31	0.37	0.32	0.00
C28 Alkane	0.22	0.29	0.23	0.00
C29 Alkane	0.16	0.22	0.15	0.00
C30 Alkane	0.00	0.16	0.00	0.00
C31 Alkane	0.00	0.00	0.00	0.00
C32 Alkane	0.00	0.00	0.00	0.00

TABLE 1-continued

Gas Chromatography Analysis of r-Pyoil Examples				
Components	r-Pyoil Feed Examples			
	1	2	3	4
Unidentified	13.73	18.59	15.44	15.91
Percent C8+	74.86	67.50	67.50	66.69
Percent C15+	28.17	22.63	22.25	10.87
Percent Aromatics	5.91	8.02	11.35	10.86
Percent Paraffins	59.72	54.85	54.19	51.59
Percent C4 to C7	11.41	13.72	16.86	17.40

r-Pyoil Examples 5-10

[0470] Six r-pyoil compositions were prepared by distillation of r-pyoil samples. They were prepared by processing the material according to the procedures described below.

Example 5. r-Pyoil with at Least 90% Boiling by 350° C., 50% Boiling Between 95° C. and 200° C., and at Least 10% Boiling by 60° C.

[0471] A 250 g sample of r-pyoil from Example 3 was distilled through a 30-tray glass Oldershaw column fitted with glycol chilled condensers, thermowells containing thermometers, and a magnet operated reflux controller regulated by electronic timer. Batch distillation was conducted at atmospheric pressure with a reflux rate of 1:1. Liquid fractions were collected every 20 mL, and the overhead temperature and mass recorded to construct the boiling curve presented in FIG. 17. The distillation was repeated until approximately 635 g of material was collected.

Example 6. r-Pyoil with at Least 90% Boiling by 150° C., 50% Boiling Between 80° C. and 145° C., and at Least 10% Boiling by 60° C.

[0472] A 150 g sample of r-pyoil from Example 3 was distilled through a 30-tray glass Oldershaw column fitted with glycol chilled condensers, thermowells containing thermometers, and a magnet operated reflux controller regulated by electronic timer. Batch distillation was conducted at atmospheric pressure with a reflux rate of 1:1. Liquid fractions were collected every 20 mL, and the overhead temperature and mass recorded to construct the boiling curve presented in FIG. 18. The distillation was repeated until approximately 200 g of material was collected.

Example 7. r-Pyoil with at Least 90% Boiling by 350° C., at Least 10% by 150° C., and 50% Boiling Between 220° C. and 280° C.

[0473] A procedure similar to Example 8 was followed with fractions collected from 120° C. to 210° C. at atmospheric pressure and the remaining fractions (up to 300° C., corrected to atmospheric pressure) under 75 torr vacuum to give a composition of 200 g with a boiling point curve described by FIG. 19.

Example 8. r-Pyoil with 90% Boiling Between 250-300° C.

[0474] Approximately 200 g of residuals from Example 6 were distilled through a 20-tray glass Oldershaw column fitted with glycol chilled condensers, thermowells contain-

ing thermometers, and a magnet operated reflux controller regulated by electronic timer. One neck of the base pot was fitted with a rubber septum, and a low flow N₂ purge was bubbled into the base mixture by means of an 18" long, 20-gauge steel thermometer. Batch distillation was conducted at 70 torr vacuum with a reflux rate of 1:2. Temperature measurement, pressure measurement, and timer control were provided by a Camille Laboratory Data Collection System. Liquid fractions were collected every 20 mL, and the overhead temperature and mass recorded. Overhead temperatures were corrected to atmospheric boiling point by means of the Clausius-Clapeyron Equation to construct the boiling curve presented in FIG. 20 below. Approximately 150 g of overhead material was collected.

Example 9. r-Pyoil with 50% Boiling Between 60-80° C.

[0475] A procedure similar to Example 5 was followed with fractions collected boiling between 60° C. and 230° C. to give a composition of 200 g with a boiling point curve described by FIG. 21.

Example 10. r-Pyoil with High Aromatic Content

[0476] A 250 g sample of r-pyoil with high aromatic content was distilled through a 30-tray glass Oldershaw column fitted with glycol chilled condensers, thermowells containing thermometers, and a magnet operated reflux controller regulated by electronic timer. Batch distillation was conducted at atmospheric pressure with a reflux rate of 1:1. Liquid fractions were collected every 10-20 mL, and the overhead temperature and mass recorded to construct the boiling curve presented in FIG. 22. The distillation ceased after approximately 200 g of material were collected. The material contains 34 weight percent aromatic content by gas chromatography analysis.

[0477] Table 2 shows the composition of Examples 5-10 by gas chromatography analysis.

TABLE 2

Gas Chromatography Analysis of r-Pyoil Examples 5-10.						
Components	r-Pyoil Examples					
	5	6	7	8	9	10
Propene	0.00	0.00	0.00	0.00	0.00	0.00
Propane	0.00	0.10	0.00	0.00	0.00	0.00
1,3-r-Butadiene	0.27	1.69	0.00	0.00	0.00	0.18
Pentene	0.44	1.43	0.00	0.00	0.00	0.48
Pentane	3.95	4.00	0.00	0.00	0.37	4.59
Unknown 1	0.09	0.28	0.00	0.00	0.00	0.07
1,3-cyclopentadiene	0.00	0.13	0.00	0.00	0.00	0.00
2-methyl-Pentene	2.75	3.00	0.00	0.00	5.79	4.98
2-methyl-Pentane	2.63	6.71	0.00	0.00	9.92	5.56
Hexane	0.75	4.77	0.00	0.00	11.13	3.71
2-methyl-1,3-cyclopentadiene	0.00	0.20	0.00	0.00	0.96	0.30
1-methyl-1,3-cyclopentadiene	0.00	0.00	0.00	0.00	0.00	0.00
2,4 dimethylpentene	0.00	0.35	0.00	0.00	2.06	0.26
Benzene	0.00	0.24	0.00	0.00	1.11	0.26
5-methyl-1,3-cyclopentadiene	0.00	0.09	0.00	0.00	0.15	0.15
Heptene	0.52	5.50	0.00	0.00	6.22	2.97
Heptane	0.13	7.35	0.17	0.00	10.16	6.85
Toluene	1.18	2.79	0.69	0.00	2.39	6.98
4-methylheptane	2.54	2.46	3.29	0.00	1.16	3.92
Octene	3.09	4.72	2.50	0.00	0.48	2.62
Octane	5.77	6.27	3.49	0.00	0.65	4.50
2,4-dimethylheptene	3.92	2.30	0.61	0.00	0.96	2.58

TABLE 2-continued

Gas Chromatography Analysis of r-Pyoil Examples 5-10.						
Components	r-Pyoil Examples					
	5	6	7	8	9	10
2,4-dimethylheptane	9.47	5.80	1.30	0.00	3.74	0.00
Ethylbenzene	0.00	0.00	1.32	0.00	2.43	7.81
m,p-xylene	7.48	4.36	0.23	0.00	1.09	15.18
Styrene	0.90	1.80	0.40	0.00	2.32	1.47
o-xylene	0.28	0.00	0.12	0.00	0.00	0.00
Nonane	3.74	5.94	0.41	0.00	6.15	2.55
Nonene	1.45	3.87	0.84	0.00	2.53	1.14
MW140	2.36	1.94	1.63	0.00	3.69	2.35
Cumene	1.30	1.23	0.54	0.00	2.13	2.43
Decene/methylstyrene	1.54	1.60	1.55	0.00	0.30	0.48
Decane	4.31	1.68	4.34	0.00	0.48	1.08
Unknown 2	0.96	0.15	0.97	0.00	0.00	0.24
Indene	0.25	0.00	0.21	0.00	0.00	0.00
Indane	0.33	0.00	0.33	0.00	0.00	0.08
C11 Alkene	1.83	0.22	1.83	0.00	0.00	0.19
C11 Alkane	4.54	0.18	4.75	0.00	0.00	0.39
C12 Alkene	1.68	0.08	2.34	0.00	0.18	0.08
Naphthalene	0.09	0.00	0.11	0.00	0.00	0.00
C12 Alkane	4.28	0.09	6.14	0.00	0.84	0.16
C13 Alkene	4.11	0.00	6.80	3.32	0.68	0.08
C13 Alkane	1.67	0.00	2.85	0.38	0.37	0.00
2-methylnaphthalene	0.70	0.00	0.00	0.93	0.14	0.00
C14 Alkene	0.08	0.00	1.81	3.52	0.00	0.00
C14 Alkane	0.14	0.09	6.20	14.12	0.00	0.00
Acenaphthylene	0.00	0.00	0.75	0.00	0.00	0.00
C15 Alkene	0.00	0.00	2.70	3.55	0.00	0.00
C15 Alkane	0.00	0.09	9.40	14.16	0.00	0.07
C16 Alkene	0.00	0.00	1.61	2.20	0.00	0.00
C16 Alkane	0.00	0.10	5.44	12.40	0.00	0.00
C17 Alkene	0.00	0.00	0.10	3.35	0.00	0.00
C17 Alkane	0.00	0.10	0.26	16.81	0.00	0.00
C18 Alkene	0.00	0.00	0.00	0.67	0.00	0.00
C18 Alkane	0.00	0.10	0.00	3.31	0.00	0.00
C19 Alkene	0.00	0.00	0.00	0.13	0.00	0.00
C19 Alkane	0.00	0.00	0.00	0.00	0.00	0.00
C20 Alkene	0.00	0.00	0.00	0.00	0.00	0.00
C20 Alkane	0.00	0.00	0.00	0.00	0.00	0.00
C21 Alkene	0.00	0.00	0.00	0.00	0.00	0.00
Unidentified	18.51	16.18	21.95	21.13	19.45	13.24
Percent C4-C7	12.71	38.55	0.85	0.00	50.25	37.35
Percent C8+	68.78	45.17	77.20	78.87	30.30	49.41
Percent C15+	0.00	0.38	19.52	56.60	0.00	0.07
Percent Aromatics	14.04	12.02	6.27	0.93	11.90	34.70
Percent Paraffins	52.35	59.75	55.64	64.26	56.08	44.89

Examples 11-58 Involving Steam Cracking r-Pyoil in a Lab Unit

[0478] The invention is further illustrated by the following steam cracking examples. Examples were performed in a laboratory unit to simulate the results obtained in a commercial steam cracker. A drawing of the lab steam cracker is shown in FIG. 11. Lab Steam Cracker 910 consisted of a section of 3/8 inch Incoloy™ tubing 912 that was heated in a 24-inch Applied Test Systems three zone furnace 920. Each zone (Zone 1 922a, Zone 2 922b, and Zone 3 922c) in the furnace was heated by a 7-inch section of electrical coils. Thermocouples 924a, 924b, and 924c were fastened to the external walls at the mid-point of each zone for temperature control of the reactor. Internal reactor thermocouples 926a and 926b were also placed at the exit of Zone 1 and the exit of Zone 2, respectively. The r-pyoil source 930 was fed through line 980 to Isco syringe pump 990 and fed to the reactor through line 981a. The water source 940 was fed through line 982 to ICSO syringe pump 992 and fed to

preheater 942 through line 983a for conversion to steam prior to entering the reactor in line 981a with pyoil. A propane cylinder 950 was attached by line 984 to mass flow controller 994. The plant nitrogen source 970 was attached by line 988 to mass flow controller 996. The propane or nitrogen stream was fed through line 983a to preheater 942 to facilitate even steam generation prior to entering the reactor in line 981a. Quartz glass wool was placed in the 1 inch space between the three zones of the furnace to reduce temperature gradients between them. In an optional configuration, the top internal thermocouple 922a was removed for a few examples to feed r-pyoil either at the mid-point of Zone 1 or at the transition between Zone 1 and Zone 2 through a section of 1/8 inch diameter tubing. The dashed lines in FIG. 11 show the optional configurations. A heavier dashed line extends the feed point to the transition between Zone 1 and Zone 2. Steam was also optionally added at these positions in the reactor by feeding water from Isco syringe pump 992 through the dashed line 983b. r-Pyoil, and optionally steam, were then fed through dashed line 981b to the reactor. Thus, the reactor can be operated by feeding various combinations of components and at various locations. Typical operating conditions were heating the first zone to 600° C., the second zone to about 700° C., and the third zone to 375° C. while maintaining 3 psig at the reactor exit. Typical flow rates of hydrocarbon feed and steam resulted in a 0.5 sec residence time in one 7-inch section of the furnace. The first 7-inch section of the furnace 922a was operated as the convection zone and the second 7-inch section 922b as the radiant zone of a steam cracker. The gaseous effluent of the reactor exited the reactor through line 972. The stream was cooled with shell and tube condenser 934 and any condensed liquids were collected in glycol cooled sight glass 936. The liquid material was removed periodically through line 978 for weighing and gas chromatography analysis. The gas stream was fed through line 976a for venting through a back-pressure regulator that maintained about 3 pig on the unit. The flow rate was measured with a Sensidyne Gilian Gilibrator-2 Calibrator. Periodically a portion of the gas stream was sent in line 976b to a gas chromatography sampling system for analysis. The unit could be operated in a decoking mode by physically disconnecting propane line 984 and attaching air cylinder 960 with line 986 and flexible tubing line 974a to mass flow controlled 994.

[0479] Analysis of reaction feed components and products was done by gas chromatography. All percentages are by weight unless specified otherwise. Liquid samples were analyzed on an Agilent 7890A using a Restek RTX-1 column (30 meters×320 micron ID, 0.5 micron film thickness) over a temperature range of 35° C. to 300° C. and a flame ionization detector. Gas samples were analyzed on an Agilent 8890 gas chromatograph. This GC was configured to analyze refinery gas up to C₆ with H₂S content. The system used four valves, three detectors, 2 packed columns, 2

micro-packed columns, and 2 capillary columns. The columns used were the following: 2 ft x 1/16 in, 1 mm i.d. HayeSep A 80/100 mesh UltiMetal Plus 41 mm; 1.7 m x 1/16 in, 1 mm i.d. HayeSep A 80/100 mesh UltiMetal Plus 41 mm; 2 m x 1/16 in, 1 mm i.d. MolSieve 13×80/100 mesh UltiMetal Plus 41 mm; 3 ft x 1/8 in, 2.1 mm i.d. HayeSep Q 80/100 mesh in UltiMetal Plus; 8 ft x 1/8 in, 2.1 mm i.d. Molecular Sieve 5A 60/80 mesh in UltiMetal Plus; 2m x 0.32 mm, 5 um thickness DB-1 (123-1015, cut); 25 m x 0.32 mm, 8 um thickness HP-AL/S (19091P-S12). The FID channel was configured to analyze the hydrocarbons with the capillary columns from C₁ to C₅, while C₆/C₆₊ components are backflushed and measured as one peak at the beginning of the analysis. The first channel (reference gas He) was configured to analyze fixed gases (such as CO₂, CO, O₂, N₂, and H₂S.). This channel was run isothermally, with all micro-packed columns installed inside a valve oven. The second TCD channel (third detector, reference gas N₂) analyzed hydrogen through regular packed columns. The analyses from both chromatographs were combined based on the mass of each stream (gas and liquid where present) to provide an overall assay for the reactor. A typical run was made as follows:

[0480] Nitrogen (130 sccm) was purged through the reactor system, and the reactor was heated (zone1, zone 2, zone 3 setpoints 300° C., 450° C., 300° ° C., respectively). Preheaters and cooler for post-reactor liquid collection were powered on. After 15 minutes and the preheater was above 100° C., 0.1 mL/min water was added to the preheater to generate steam. The reactor temperature setpoints were raised to 450° C., 600° ° C., and 350° C. for zones 1, 2, and 3, respectively. After another 10 minutes, the reactor temperature setpoints were raised to 600° ° C., 700° C., and 375° C. for zones 1, 2, and 3, respectively. The N₂ was decreased to zero as the propane flow was increased to 130 sccm. After 100 min at these conditions either r-pyoil or r-pyoil in naphtha was introduced, and the propane flow was reduced. The propane flow was 104 sccm, and the r-pyoil feed rate was 0.051 g/hr for a run with 80% propane and 20% r-pyoil. This material was steam cracked for 4.5 hr (with gas and liquid sampling). Then, 130 sccm propane flow was reestablished. After 1 hr, the reactor was cooled and purged with nitrogen.

Steam Cracking with r-Pyoil Example 1

[0481] Table 3 contains examples of runs made in the lab steam cracker with propane, r-pyoil from Example 1, and various weight ratios of the two. Steam was fed to the reactor in a 0.4 steam to hydrocarbon ratio in all runs. Nitrogen (5% by weight relative to the hydrocarbon) was fed with steam in the run with only r-pyoil to aid in even steam generation. Comparative Example 1 is an example involving cracking only propane.

TABLE 3

Steam Cracking Examples using r-pyoil from Example 1.

Examples	Comparative					
	Example 1	11	12	13	14	15
Zone 2 Control Temp	700	700	700	700	700	700
Propane (wt %)	100	85	80	67	50	0
r-Pyoil (wt %)	0	15	20	33	50	100*

TABLE 3-continued

Steam Cracking Examples using r-pyoil from Example 1.						
Examples	Comparative Example 1	11	12	13	14	15
Feed Wt, g/hr	15.36	15.43	15.35	15.4	15.33	15.35
Steam/Hydrocarbon Ratio	0.4	0.4	0.4	0.4	0.4	0.4
Total Accountability, %	103.7	94.9	94.5	89.8	87.7	86
Total Products	Weight Percent					
C6+	1.15	2.61	2.62	4.38	7.78	26.14
methane	18.04	18.40	17.68	17.51	17.52	12.30
ethane	2.19	2.59	2.46	2.55	2.88	2.44
ethylene	30.69	32.25	31.80	32.36	32.97	23.09
propane	24.04	19.11	20.25	16.87	11.66	0.33
propylene	17.82	17.40	17.63	16.80	15.36	7.34
i-butane	0.00	0.04	0.04	0.03	0.03	0.01
n-butane	0.03	0.02	0.02	0.02	0.02	0.02
propyldiene	0.07	0.14	0.13	0.15	0.17	0.14
acetylene	0.24	0.40	0.40	0.45	0.48	0.41
r-2-butene	0.00	0.19	0.00	0.00	0.00	0.11
1-butene	0.16	0.85	0.19	0.19	0.20	0.23
i-butylene	0.92	0.34	0.87	0.81	0.66	0.81
c-2-butene	0.12	0.15	0.40	0.56	0.73	0.11
i-pentane	0.13	0.00	0.00	0.00	0.00	0.00
n-pentane	0.00	0.01	0.01	0.02	0.02	0.02
1,3-butadiene	1.73	2.26	2.31	2.63	3.02	2.88
methyl acetylene	0.20	0.26	0.26	0.30	0.32	0.28
r-2-pentene	0.11	0.08	0.12	0.12	0.12	0.05
2-methyl-2-butene	0.02	0.01	0.03	0.03	0.02	0.02
1-pentene	0.05	0.09	0.01	0.02	0.02	0.03
c-2-pentene	0.06	0.01	0.03	0.03	0.03	0.01
pentadiene 1	0.00	0.01	0.02	0.02	0.02	0.08
pentadiene 2	0.01	0.04	0.04	0.05	0.06	0.16
pentadiene 3	0.12	0.21	0.23	0.27	0.30	0.26
1,3-Cyclopentadiene	0.48	0.85	0.81	1.01	1.25	1.58
pentadiene 4	0.00	0.08	0.08	0.09	0.10	0.07
pentadiene 5	0.06	0.17	0.17	0.20	0.23	0.31
CO2	0.00	0.00	0.00	0.00	0.00	0.00
CO	0.12	0.11	0.05	0.00	0.12	0.74
hydrogen	1.40	1.31	1.27	1.21	1.13	0.67
Unidentified	0.00	0.00	0.10	1.33	2.79	19.37
Olefin/Aromatics Ratio	45.42	21.07	20.91	12.62	7.11	1.42
Total Aromatics	1.15	2.61	2.62	4.38	7.78	26.14
Propylene + Ethylene	48.51	49.66	49.43	49.16	48.34	30.43
Ethylene/Propylene Ratio	1.72	1.85	1.80	1.93	2.15	3.14

*5% N2 was also added to facilitate steam generation. Analysis has been normalized to exclude it.

[0482] As the amount of r-pyoil used is increased relative to propane, there was an increase in the formation of dienes. For example, both r-butadiene and cyclopentadiene increased as more r-pyoil is added to the feed. Additionally, aromatics (C6+) increased considerably with increased r-pyoil in the feed.

[0483] Accountability decreased with increasing amounts of r-pyoil in these examples. It was determined that some r-pyoil in the feed was being held up in the preheater section. Due to the short run times, accountability was negatively affected. A slight increase in the slope of the reactor inlet line corrected the issue (see Example 24). Nonetheless, even with an accountability of 86% in Example 15, the trend was clear. The overall yield of r-ethylene and r-propylene decreased from about 50% to less than about 35% as the amount of r-pyoil in the feed increased. Indeed, feeding r-pyoil alone produced about 40% of aromatics (C6+) and unidentified higher boilers (see Example 15 and Example 24).

[0484] r-Ethylene Yield-r-Ethylene yield showed an increase from 30.7% to >32% as 15% r-pyoil was co-cracked with propane. The yield of r-ethylene then remained

about 32% until >50% r-pyoil was used. With 100% r-pyoil, the yield of r-ethylene decreased to 21.5% due to the large amount of aromatics and unidentified high boilers (>40%). Since r-pyoil cracks faster than propane, a feed with an increased amount of r-pyoil will crack faster to more r-propylene. The r-propylene can then react to form r-ethylene, diene and aromatics. When the concentration of r-pyoil was increased the amount of r-propylene cracked products was also increased. Thus, the increased amount of dienes can react with other dienes and olefins (like r-ethylene) leading to even more aromatics formation. So, at 100% r-pyoil in the feed, the amount of r-ethylene and r-propylene recovered was lower due to the high concentration of aromatics that formed. In fact, the olefin/aromatic dropped from 45.4 to 1.4 as r-pyoil was increased to 100% in the feed. Thus, the yield of r-ethylene increased as more r-pyoil was added to the feed mixture, at least to about 50% r-pyoil. Feeding pyoil in propane provides a way to increase the ethylene/propylene ratio on a steam cracker.

[0485] r-Propylene Yield-r-Propylene yield decreased with more r-pyoil in the feed. It dropped from 17.8% with propane only to 17.4% with 15% r-pyoil and then to 6.8%

as 100% r-pyoil was cracked. r-Propylene formation did not decrease in these cases. r-Pyoil cracks at lower temperature than propane. As r-propylene is formed earlier in the reactor it has more time to be converted to other materials-like dienes and aromatics and r-ethylene. Thus, feeding r-pyoil with propane to a cracker provides a way to increase the yield of ethylene, dienes and aromatics.

[0486] The r-ethylene/r-propylene ratio increased as more r-pyoil was added to the feed because an increase concentration of r-pyoil made r-propylene faster, and the r-propylene reacted to other cracked products-like dienes, aromatics and r-ethylene.

[0487] The ethylene to propylene ratio increased from 1.72 to 3.14 going from 100% propane to 100% r-pyoil cracking. The ratio was lower for 15% r-pyoil (0.54) than 20% r-pyoil (0.55) due to experimental error with the small change in r-pyoil feed and the error from having just one run at each condition.

[0488] The olefin/aromatic ratio decreased from 45 with no r-pyoil in the feed to 1.4 with no propane in the feed. The decrease occurred mainly because r-pyoil cracked more readily than propane and thus more r-propylene was produced faster. This gave the r-propylene more time to react further—to make more r-ethylene, dienes, and aromatics. Thus, aromatics increased, and r-propylene decreased with the olefin/aromatic ratio decreasing as a result.

[0489] r-Butadiene increased as the concentration of r-pyoil in the feed increased, thus providing a way to increase r-butadiene yield. r-Butadiene increased from 1.73% with propane cracking, to about 2.3% with 15-20% r-pyoil in the feed, to 2.63% with 33% r-pyoil, and to 3.02% with 50% r-pyoil. The amount was 2.88% at 100% r-pyoil. Example 24 showed 3.37% r-butadiene observed in another run with 100% r-pyoil. This amount may be a more accurate value based on the accountability problems that occurred in Example 15. The increase in r-butadiene was the result of more severity in cracking as products like r-propylene continued to crack to other materials.

[0490] Cyclopentadiene increased with increasing r-pyoil except for the decrease in going from 15%-20% r-pyoil (from 0.85 to 0.81). Again, some experimental error was likely. Thus, cyclopentadiene increased from 0.48% cracking propane only, to about 0.85% at 15-20% r-pyoil in the reactor feed, to 1.01% with 33% r-pyoil, to 1.25 with 50% r-pyoil, and 1.58% with 100% r-pyoil. The increase in cyclobutadiene was also the result of more severity in cracking as products like r-propylene continued to crack to other materials. Thus, cracking r-pyoil with propane provided a way to increase cyclopentadiene production.

[0491] Operating with r-pyoil in the feed to the steam cracker resulted in less propane in the reactor effluent. In commercial operation, this would result in a decreased mass flow in the recycle loop. The lower flow would decrease cryogenic energy costs and potentially increase capacity on the plant if it is capacity constrained. Additionally, lower propane in the recycle loop would debottleneck the r-propylene fractionator if it is already capacity limited.

Steam Cracking with r-Pyoil Examples 1-4

[0492] Table 4 contains examples of runs made with the r-pyoil samples found in Table 1 with a propane/r-pyoil weight ratio of 80/20 and 0.4 steam to hydrocarbon ratio.

TABLE 4

Examples using r-PyOil Examples 1-4 under similar conditions.				
Examples	16	17	18	19
r-Pyoil from Table 1	1	2	3	4
Zone 2 Control Temp	700	700	700	700
Propane (wt %)	80	80	80	80
r-Pyoil (wt %)	20	20	20	20
N2 (wt %)	0	0	0	0
Feed Wt, g/hr	15.35	15.35	15.35	15.35
Steam/Hydrocarbon Ratio	0.4	0.4	0.4	0.4
Total Accountability, %	94.5	96.4	95.6	95.3
Total Products	Weight Percent			
C6+	2.62	2.86	3.11	2.85
methane	17.68	17.36	17.97	17.20
ethane	2.46	2.55	2.67	2.47
ethylene	31.80	30.83	31.58	30.64
propane	20.25	21.54	19.34	21.34
propylene	17.63	17.32	17.18	17.37
i-butane	0.04	0.04	0.04	0.04
n-butane	0.02	0.01	0.02	0.03
propadiene	0.13	0.06	0.09	0.12
acetylene	0.40	0.11	0.26	0.37
t-2-butene	0.00	0.00	0.00	0.00
1-butene	0.19	0.19	0.20	0.19
i-butylene	0.87	0.91	0.91	0.98
c-2-butene	0.40	0.44	0.45	0.52
i-pentane	0.00	0.14	0.16	0.16
n-pentane	0.01	0.03	0.03	0.03
1,3-butadiene	2.31	2.28	2.33	2.27
methyl acetylene	0.26	0.23	0.23	0.24
t-2-pentene	0.12	0.13	0.14	0.13
2-methyl-2-butene	0.03	0.04	0.04	0.03
1-pentene	0.01	0.02	0.02	0.02
c-2-pentene	0.03	0.06	0.05	0.04
pentadiene 1	0.02	0.00	0.00	0.00
pentadiene 2	0.04	0.02	0.02	0.01
pentadiene 3	0.23	0.17	0.00	0.25
1,3-Cyclopentadiene	0.81	0.72	0.76	0.71
pentadiene 4	0.08	0.00	0.00	0.00
pentadiene 5	0.17	0.08	0.09	0.08
CO2	0.00	0.00	0.00	0.00
CO	0.05	0.00	0.00	0.00
hydrogen	1.27	1.22	1.26	1.21
Unidentified	0.10	0.65	1.04	0.69
Olefin/Aromatics Ratio	20.91	18.66	17.30	18.75
Total Aromatics	2.62	2.86	3.11	2.85
Propylene + Ethylene	49.43	48.14	48.77	48.01
Ethylene/Propylene Ratio	1.80	1.78	1.84	1.76

[0493] Steam cracking of the different r-pyoil Examples 1-4 at the same conditions gave similar results. Even the lab distilled sample of r-pyoil (Example 19) cracked like the other samples. The highest r-ethylene and r-propylene yield was for Example 16, but the range was 48.01-49.43. The r-ethylene/r-propylene ratio varied from 1.76 to 1.84. The amount of aromatics (C6+) only varied from 2.62 to 3.11. Example 16 also produced the smallest yield of aromatics. The r-pyoil used for this example (r-Pyoil Example 1, Table 1) contained the largest amount of paraffins and the lowest amount of aromatics. Both are desirable for cracking to r-ethylene and r-propylene.

Steam Cracking with r-Pyoil Example 2

[0494] Table 5 contains runs made in the lab steam cracker with propane (Comparative Example 2), r-pyoil Example 2, and four runs with a propane/pyrolysis oil weight ratio of 80/20. Comparative Example 2 and Example 20 were run with a 0.2 steam to hydrocarbon ratio. Steam was fed to the reactor in a 0.4 steam to hydrocarbon ratio in all other

examples. Nitrogen (5% by weight relative to the r-pyoil) was fed with steam in the run with only r-pyoil (Example 24).

amount of other components: r-ethylene, C6+(aromatics), r-butadiene, cyclopentadiene, etc., than found in Example 20.

TABLE 5

Examples using r-Pyoil Example 2.						
Examples	Comparative Example 2	20	21	22	23	24
Zone 2 Control Temp	700° C.	700° C.	700° C.	700° C.	700° C.	700° C.
Propane (wt %)	100	80	80	80	80	0
r-Pyoil (wt %)	0	20	20	20	20	100*
Feed Wt, g/hr	15.36	15.35	15.35	15.35	15.35	15.35
Steam/Hydrocarbon Ratio	0.2	0.2	0.4	0.4	0.4	0.4
Total Accountability, %	100.3	93.8	99.1	93.4	96.4	97.9
Total Products	Weight Percent					
C6+	1.36	2.97	2.53	2.98	2.86	22.54
methane	18.59	19.59	17.34	16.64	17.36	11.41
ethane	2.56	3.09	2.26	2.35	2.55	3.00
ethylene	30.70	32.51	31.19	29.89	30.83	24.88
propane	23.00	17.28	21.63	23.84	21.54	0.38
propylene	18.06	16.78	17.72	17.24	17.32	10.94
i-butane	0.04	0.03	0.03	0.05	0.04	0.02
n-butane	0.01	0.03	0.03	0.03	0.01	0.09
propadiene	0.05	0.10	0.12	0.12	0.06	0.12
acetylene	0.12	0.35	0.40	0.36	0.11	0.31
t-2-butene	0.00	0.00	0.00	0.00	0.00	0.00
1-butene	0.17	0.20	0.18	0.18	0.19	0.25
i-butylene	0.87	0.80	0.91	0.94	0.91	1.22
c-2-butene	0.14	0.40	0.40	0.44	0.44	1.47
i-pentane	0.14	0.13	0.00	0.00	0.14	0.13
n-pentane	0.00	0.01	0.02	0.03	0.03	0.01
1,3-butadiene	1.74	2.35	2.20	2.18	2.28	3.37
methyl acetylene	0.18	0.22	0.26	0.24	0.23	0.23
t-2-pentene	0.13	0.14	0.12	0.12	0.13	0.14
2-methyl-2-butene	0.03	0.04	0.03	0.04	0.04	0.10
1-pentene	0.01	0.03	0.01	0.01	0.02	0.05
c-2-pentene	0.04	0.04	0.03	0.04	0.06	0.18
pentadiene 1	0.00	0.01	0.01	0.02	0.00	0.14
pentadiene 2	0.01	0.02	0.03	0.02	0.02	0.19
pentadiene 3	0.00	0.24	0.19	0.24	0.17	0.50
1,3-Cyclopentadiene	0.52	0.83	0.65	0.71	0.72	1.44
pentadiene 4	0.00	0.00	0.00	0.00	0.00	0.01
pentadiene 5	0.06	0.09	0.08	0.08	0.08	0.15
CO2	0.00	0.00	0.00	0.00	0.00	0.00
CO	0.07	0.00	0.00	0.00	0.00	0.19
hydrogen	1.36	1.28	1.28	1.21	1.22	0.63
Unidentified	0.00	0.00	0.34	0.00	0.65	15.89
Olefin/Aromatics Ratio	38.54	18.39	21.26	17.55	18.66	2.00
Total Aromatics	1.36	2.97	2.53	2.98	2.86	22.54
Propylene + Ethylene	48.76	49.29	48.91	47.13	48.14	35.82
Ethylene/Propylene Ratio	1.70	1.94	1.76	1.73	1.78	2.27

*5% N2 was also added to facilitate steam generation. Analysis has been normalized to exclude it.

[0495] Comparing Example 20 to Examples 21-23 shows that the increased feed flow rate (from 192 sccm in Example 20 to 255 sccm with more steam in Examples 21-23) resulted in less conversion of propane and r-pyoil due to the 25% shorter residence time in the reactor (r-ethylene and r-propylene: 49.3% for Example 20 vs 47.1, 48.1, 48.9% for Examples 21-23). r-Ethylene was higher in Example 21 with the increased residence time since propane and r-pyoil cracked to higher conversion of r-ethylene and r-propylene and some of the r-propylene can then be converted to additional r-ethylene. And conversely, r-propylene was higher in the higher flow examples with a higher steam to hydrocarbon ratio (Example 21-23) since it has less time to continue reacting. Thus, Examples 21-23 produced a smaller

[0496] Examples 21-23 were run at the same conditions and showed that there was some variability in operation of the lab unit, but it was sufficiently small that trends can be seen when different conditions are used.

[0497] Example 24, like example 15, showed that the r-propylene and r-ethylene yield decreased when 100% r-pyoil was cracked compared to feed with 20% r-pyoil. The amount decreased from about 48% (in Examples 21-23) to 36%. Total aromatics was greater than 20% of the product as in Example 15.

Steam Cracking with r-Pyoil Example 3

[0498] Table 6 contains runs made in the lab steam cracker with propane and r-pyoil Example 3 at different steam to hydrocarbon ratios.

TABLE 6

Examples using r-Pyoil Example 3.		
Examples	25	26
Zone 2 Control Temp	700° C.	700° C.
Propane (wt %)	80	80
r-Pyoil (wt %)	20	20
N2 (wt %)	0	0
Feed Wt, g/hr	15.33	15.33
Steam/Hydrocarbon Ratio	0.4	0.2
Total Accountability, %	95.6	92.1
Total Products	Weight Percent	
C6+	3.11	3.42
methane	17.97	18.57
ethane	2.67	3.01
ethylene	31.58	31.97
propane	19.34	17.43
propylene	17.18	17.17
i-butane	0.04	0.04
n-butane	0.02	0.03
propadiene	0.09	0.10
acetylene	0.26	0.35
t-2-butene	0.00	0.00
1-butene	0.20	0.20
i-butylene	0.91	0.88
c-2-butene	0.45	0.45
i-pentane	0.16	0.17
n-pentane	0.03	0.02
1,3-butadiene	2.33	2.35
methyl acetylene	0.23	0.22
t-2-pentene	0.14	0.15
2-methyl-2-butene	0.04	0.04
1-pentene	0.02	0.02
c-2-pentene	0.05	0.04
pentadiene 1	0.00	0.00
pentadiene 2	0.02	0.02
pentadiene 3	0.00	0.25
1,3-Cyclopentadiene	0.76	0.84
pentadiene 4	0.00	0.00
pentadiene 5	0.09	0.10
CO2	0.00	0.00
CO	0.00	0.00
hydrogen	1.26	1.24
Unidentified	1.04	0.92
Olefin/Aromatics Ratio	17.30	15.98
Total Aromatics	3.11	3.42
Propylene + Ethylene	48.77	49.14
Ethylene/Propylene Ratio	1.84	1.86

TABLE 7

Examples using Pyrolysis Oil Example 4.		
Examples	27	28
Zone 2 Control Temp	700° C.	700° C.
Propane (wt %)	80	80
r-Pyoil (wt %)	20	20
N2 (wt %)	0	0
Feed Wt, g/hr	15.35	15.35
Steam/Hydrocarbon Ratio	0.4	0.6
Total Accountability, %	95.3	95.4
Total Products	Weight Percent	
C6+	2.85	2.48
methane	17.20	15.37
ethane	2.47	2.09
ethylene	30.64	28.80
propane	21.34	25.58
propylene	17.37	17.79
i-butane	0.04	0.05
n-butane	0.03	0.03
propadiene	0.12	0.12
acetylene	0.37	0.35
t-2-butene	0.00	0.00
1-butene	0.19	0.19
i-butylene	0.98	1.03
c-2-butene	0.52	0.53
i-pentane	0.16	0.15
n-pentane	0.03	0.05
1,3-butadiene	2.27	2.15
methyl acetylene	0.24	0.25
t-2-pentene	0.13	0.12
2-methyl-2-butene	0.03	0.04
1-pentene	0.02	0.02
c-2-pentene	0.04	0.05
pentadiene 1	0.00	0.00
pentadiene 2	0.01	0.02
pentadiene 3	0.25	0.27
1,3-Cyclopentadiene	0.71	0.65
pentadiene 4	0.00	0.00
pentadiene 5	0.08	0.08
CO2	0.00	0.00
CO	0.00	0.00
hydrogen	1.21	1.15
Unidentified	0.69	0.63
Olefin/Aromatics Ratio	18.75	20.94
Total Aromatics	2.85	2.48
Propylene + Ethylene	48.01	46.59
Ethylene/Propylene Ratio	1.76	1.62

[0499] The same trends observed from cracking with r-pyoil Examples 1-2 were demonstrated for cracking with propane and r-pyoil Example 3. Example 25 compared to Example 26 showed that a decrease in the feed flow rate (to 192 sccm in Example 26 with less steam from 255 sccm in Example 25) resulted in greater conversion of the propane and r-pyoil due to the 25% greater residence time in the reactor (r-ethylene and r-propylene: 48.77% for Example 22 vs 49.14% for the lower flow in Example 26). r-Ethylene was higher in Example 26 with the increased residence time since propane and r-pyoil cracked to higher conversion of r-ethylene and r-propylene and some of the r-propylene was then converted to additional r-ethylene. Thus, Example 25, with the shorter residence time produced a smaller amount of other components: r-ethylene, C6+(aromatics), r-butadiene, cyclopentadiene, etc., than found in Example 26.

Steam Cracking with r-Pyoil Example 4

[0500] Table 7 contains runs made in the lab steam cracker with propane and pyrolysis oil sample 4 at two different steam to hydrocarbon ratios.

[0501] The results in Table 7 showed the same trends as discussed with Example 20 vs Examples 21-23 in Table 5 and Example 25 vs Example 26 in Table 6. At a smaller steam to hydrocarbon ratio, higher amounts of r-ethylene and r-propylene and higher amounts of aromatics were obtained at the increased residence time. The r-ethylene/r-propylene ratio was also greater.

[0502] Thus, comparing Example 20 with Examples 21-23 in Table 5, Example 25 with Example 26, and Example 27 with Example 28 showed the same effect. Decreasing the steam to hydrocarbon ratio decreased the total flow in the reactor. This increased the residence time. As a result, there was an increase in the amount of r-ethylene and r-propylene produced. The r-ethylene to r-propylene ratio was larger which indicated that some r-propylene reacted to other products like r-ethylene. There was also an increase in aromatics (C6+) and dienes.

Examples of Cracking r-Py oils from Table 2 with Propane

[0503] Table 8 contains the results of runs made in the lab steam cracker with propane (Comparative example 3) and

the six r-pyoil samples listed in Table 2. Steam was fed to the reactor in a 0.4 steam to hydrocarbon ratio in all runs.

[0504] Examples 30, 33, and 34 were the results of runs with r-pyoil having greater than 35% C4-C7. The r-pyoil used in Example 40 contained 34.7% aromatics. Comparative Example 3 was a run with propane only. Examples 29, 31, and 32 were the results of runs with r-pyoil containing less than 35% C4-C7.

aromatic content (using r-pyoil Example 10 in Example 34). Except for that difference, the r-pyoils performed similarly, and any of them can be fed with C-2 to C-4 in a steam cracker. r-Pyoils having high aromatic content like r-pyoil Example 10 may not be the preferred feed for a steam cracker, and a r-pyoil having less than about 20% aromatic content should be considered a more preferred feed for co-cracking with ethane or propane.

TABLE 8

Examples of steam cracking with propane and r-pyoils.							
Examples	Comparative Example 3	29	30	31	32	33	34
r-Pyoil Feed from Table 2		5	6	7	8	9	10
Zone 2 Control Temp, ° C.	700	700	700	700	700	700	700
Propane (wt %)	100	80	80	80	80	80	80
r-Pyoil (wt %)	0	20	20	20	20	20	20
Feed Wt, g/hr	15.36	15.32	15.33	15.33	15.35	15.35	15.35
Steam/Hydrocarbon Ratio	0.4	0.4	0.4	0.4	0.4	0.4	0.4
Total Accountability, %	103	100	100.3	96.7	96.3	95.7	97.3
Total Products	Weight Percent						
C6+	1.13	2.86	2.64	3.03	2.34	3.16	3.00
methane	17.69	17.17	15.97	17.04	16.42	18.00	16.41
ethane	2.27	2.28	2.12	2.26	2.59	2.63	2.19
ethylene	29.85	31.03	29.23	30.81	30.73	30.80	28.99
propane	24.90	21.86	25.13	21.70	23.79	20.99	24.57
propylene	18.11	17.36	17.78	17.23	18.08	17.90	17.32
i-butane	0.05	0.04	0.05	0.04	0.05	0.04	0.05
n-butane	0.02	0.02	0.04	0.02	0.00	0.00	0.02
propadiene	0.08	0.14	0.12	0.14	0.04	0.04	0.10
acetylene	0.31	0.42	0.36	0.42	0.04	0.06	0.31
t-2-butene	0.00	0.00	0.00	0.00	0.00	0.00	0.00
1-butene	0.16	0.18	0.19	0.18	0.19	0.20	0.18
i-butylene	0.91	0.93	1.00	0.92	0.93	0.90	0.95
c-2-butene	0.13	0.51	0.50	0.50	0.34	0.68	0.61
i-pentane	0.14	0.00	0.15	0.00	0.16	0.16	0.15
n-pentane	0.00	0.04	0.05	0.04	0.00	0.00	0.06
1,3-butadiene	1.64	2.28	2.15	2.26	2.48	2.23	2.04
methyl acetylene	0.19	0.28	0.24	0.28	n/a	0.24	0.24
t-2-pentene	0.12	0.12	0.12	0.12	0.13	0.13	0.11
2-methyl-2-butene	0.03	0.03	0.03	0.03	0.04	0.03	0.03
1-pentene	0.11	0.02	0.02	0.02	0.01	0.02	0.02
c-2-pentene	0.01	0.03	0.04	0.03	0.11	0.10	0.05
pentadiene 1	0.00	0.02	0.00	0.02	0.00	0.00	0.00
pentadiene 2	0.01	0.03	0.03	0.04	0.01	0.05	0.02
pentadiene 3	0.14	0.25	0.00	0.25	0.00	0.00	0.00
1,3-Cyclopentadiene	0.44	0.77	0.69	0.77	0.22	0.30	0.63
pentadiene 4	0.00	0.00	0.00	0.00	0.00	0.00	0.00
pentadiene 5	0.06	0.08	0.08	0.08	0.09	0.08	0.07
CO ₂	0.00	0.00	0.00	0.00	0.00	0.00	0.00
CO	0.11	0.00	0.07	0.00	0.00	0.00	0.11
hydrogen	1.36	1.26	1.21	1.25	1.18	1.25	1.22
unidentified	0.00	0.00	0.00	0.52	0.00	0.00	0.56
Olefin/Aromatics Ratio	45.81	18.79	19.66	17.64	22.84	16.91	17.06
Total Aromatics	1.13	2.86	2.64	3.03	2.34	3.16	3.00
Propylene + Ethylene	47.96	48.39	47.01	48.04	48.82	48.70	46.31
Ethylene/Propylene Ratio	1.65	1.79	1.64	1.79	1.70	1.72	1.67

[0505] The examples in Table 8 involved using an 80/20 mix of propane with the various distilled r-pyoils. The results were like those in previous examples involving cracking r-pyoil with propane. All the examples produced an increase in aromatics and dienes relative to cracking propane only. As a result, the olefins to aromatic ratio was lower for cracking the combined feeds. The amount of r-propylene and r-ethylene produced was 47.01-48.82% for all examples except for the 46.31% obtained with the r-pyoil with 34.7%

Example of Steam Cracking r-Pyoils from Table 2 with Natural Gasoline

[0506] Table 9 contains the results of runs made in the lab steam cracker with a natural gasoline sample from a supplier and the r-pyoils listed in Table 2. The natural gasoline material was greater than 99% C₅-C₈ and contained greater than 70% identified paraffins and about 6% aromatics. The material had an initial boiling point of 100° F., a 50% boiling point of 128°F, a 95% boiling point of 208°F, and a final boiling point of 240° F. No component greater than C₉ were

identified in the natural gasoline sample. It was used as a typical naphtha stream for the examples.

[0507] The results presented in Table 9 include examples involving cracking the natural gasoline (Comparative example 4), or cracking a mixture of natural gasoline and the r-pyoil samples listed in Table 2. Steam was fed to the reactor in a 0.4 steam to hydrocarbon ratio in all runs. Nitrogen (5% by weight relative to the hydrocarbon) was fed with water to facilitate even steam generation. Examples 35, 37, and 38 involved runs with r-pyoils containing very little C₁₅₊. Example 38 illustrated the results of a run with greater than 50% C₁₅₊ in the r-pyoil.

[0508] The gas flow of the reactor effluent and the gas chromatography analysis of the stream were used to determine the weight of gas product, and then the weight of other liquid material needed for 100% accountability was calculated. This liquid material was typically 50-75% aromatics, and more typically 60-70%. An actual assay of the liquid sample was difficult for these examples. The liquid product in most of these examples was an emulsion that was hard to separate and assay. Since the gas analysis was reliable, this method allowed an accurate comparison of the gaseous products while still having an estimate of the liquid product if it was completely recovered.

TABLE 9

Results of Cracking r-Pyoil with Natural Gasoline.							
Examples	Comparative Example 4	35	36	37	38	39	40
r-Pyoil Feed from Table 2	Natural Gasoline	5	6	7	8	9	10
Zone 2 Control Temp	700	700	700	700	700	700	700
Natural Gasoline (wt %)	100	80	80	80	80	80	80
r-Pyoil (wt %)	0	20	20	20	20	20	20
N2 (wt %)	5*	5*	5*	5*	5*	5*	5*
Feed Wt, g/hr	15.4	15.3	15.4	15.4	15.4	15.4	15.4
Gas Exit Flow, scfm	221.2	206.7	204.5	211.8	211.3	202.6	207.8
Gas Weight Accountability, %	92.5	83.1	81.5	79.9	83.9	81.7	84.3
Total Products	Weight Percent						
C6+	9.54	7.86	6.32	8.05	7.23	7.15	5.75
methane	19.19	18.33	16.98	17.80	19.46	17.88	15.67
ethane	3.91	3.91	3.24	3.86	4.02	3.52	2.77
ethylene	27.34	26.14	28.24	24.96	27.74	26.42	29.39
propane	0.42	0.40	0.38	0.36	0.37	0.37	0.42
propylene	12.97	12.49	13.61	10.87	11.80	12.34	16.10
i-butane	0.03	0.03	0.03	0.02	0.02	0.02	0.03
n-butane	0.11	0.07	0.00	0.05	0.00	0.05	0.00
propadiene	0.22	0.18	0.10	0.18	0.08	0.22	0.11
acetylene	0.40	0.34	0.11	0.33	0.09	0.41	0.13
t-2-butene	0.00	0.00	0.00	0.00	0.00	0.00	0.00
1-butene	0.44	0.39	0.40	0.32	0.38	0.39	0.46
i-butylene	0.91	0.89	0.91	0.65	0.76	0.86	1.30
c-2-butene	2.98	2.85	2.98	2.28	2.58	2.94	3.58
i-pentane	0.08	0.03	0.02	0.05	0.04	0.03	0.02
n-pentane	5.55	1.95	0.84	2.21	1.72	1.45	1.33
1,3-butadiene	3.17	3.09	3.77	2.94	3.54	3.48	3.78
methyl acetylene	0.37	0.32	0.40	0.31	0.36	0.39	n/a
t-2-pentene	0.14	0.12	0.12	0.12	0.14	0.12	0.12
2-methyl-2-butene	0.07	0.06	0.04	0.07	0.08	0.07	0.06
1-pentene	0.10	0.08	0.08	0.09	0.11	0.10	0.09
c-2-pentene	0.20	0.17	0.07	0.19	0.12	0.09	0.08
pentadiene 1	0.35	0.12	0.02	0.19	0.13	0.09	0.06
pentadiene 2	0.80	0.52	0.16	0.59	0.54	0.40	0.29
pentadiene 3	0.48	0.10	0.00	0.46	0.00	0.00	0.00
1,3-Cyclopentadiene	1.03	1.00	0.56	0.98	0.56	1.09	0.56
pentadiene 4	0.00	0.00	0.00	0.00	0.00	0.00	0.00
pentadiene 5	0.11	0.11	0.13	0.10	0.13	0.12	0.00
CO2	0.01	0.00	0.00	0.00	0.00	0.00	0.00
CO	0.00	0.00	0.10	0.00	0.00	0.06	0.13
hydrogen	1.00	0.92	0.94	0.87	0.95	0.93	1.03
Other High Boilers-calculated**	8.09	17.54	19.45	21.12	17.06	19.01	16.75
C6+ and Other Calculated High Boilers	17.63	25.40	25.77	29.17	24.28	26.17	22.50
Ethylene and Propylene	40.31	38.63	41.86	35.83	39.54	38.76	45.48
Ethylene/Propylene Ratio	2.11	2.09	2.07	2.30	2.35	2.14	1.83
Olefin/Aromatics in gas effluent	5.38	6.15	8.10	5.59	6.74	6.81	9.74

*5% Nitrogen was also added to facilitate steam generation. Analysis has been normalized to exclude it.

**Calculated theoretical amount needed for 100% accountability based on the actual reactor effluent gas flow rate and gas chromatography analysis.

[0509] The cracking examples in Table 9 involved using an 80/20 mix of natural gasoline with the various distilled r-pyoils. The natural gasoline and r-pyoils examples produced an increase in C₆₊(aromatics), unidentified high boilers, and dienes relative to cracking propane only or r-pyoil and propane (see Table 8). The increase in aromatics in the gas phase was about double compared to cracking 20% by weight r-pyoil with propane. Since the liquid product was typically greater than 60% aromatics, the total amount of aromatics was probably 5 times greater than cracking 20% by weight r-pyoil with propane. The amount of r-propylene and r-ethylene produced was generally lower by about 10%. The r-ethylene and r-propylene yield ranged from 35.83-41.86% for all examples except for the 45.48% obtained with high aromatic r-pyoil (using Example 10 material in Example 40). This is almost in the range of the yields obtained from cracking r-pyoil and propane (46.3-48.8% in Table 7). Example 40 produced the highest amount of r-propylene (16.1%) and the highest amount of r-ethylene (29.39%). This material also produced the lowest r-ethylene/r-propylene ratio which suggests that there was less conversion of r-propylene to other products than in the other examples. This result was unanticipated. The high concen-

tration of aromatics (34.7%) in the r-pyoil feed appeared to inhibit further reaction of r-propylene. It is thought that r-pyoils having an aromatic content of 25-50% will see similar results. Co-cracking this material with natural gasoline also produced the lowest amount of C₆₊ and unidentified high boilers, but this stream produced the most r-butadiene. The natural gasoline and r-pyoil both cracked easier than propane so the r-propylene that formed reacted to give the increase in r-ethylene, aromatics, dienes, and others. Thus, the r-ethylene/r-propylene ratio was above 2 in all these examples, except in Example 40. The ratio in this example (1.83) was similar to the 1.65-1.79 range observed in Table 8 for cracking r-pyoil and propane. Except for these differences, the r-pyoils performed similarly and any of them can be fed with naphtha in a steam cracker.

Steam Cracking r-Pyoil with Ethane

[0510] Table 10 shows the results of cracking ethane and propane alone, and cracking with r-pyoil Example 2. The examples from cracking either ethane or ethane and r-pyoil were operated at three Zone 2 control temperatures: 700° C., 705° C., and 710° C.

TABLE 10

Examples of Cracking Ethane and r-pyoil at different temperatures.								
Examples	Comparative Example 5	41	Comparative Example 6	42	Comparative Example 7	43	Comparative Example 3	Comparative Example 8
Zone 2 Control Temp	700° C.	700° C.	705° C.	705° C.	710° C.	710° C.	700° C.	700° C.
Propane or Ethane in Feed	Ethane	Ethane	Ethane	Ethane	Ethane	Ethane	Propane	Propane
Propane or Ethane (wt %)	100	80	100	80	100	80	100	80
r-Pyoil (wt %)	0	20	0	20	0	20	0	20
Feed Wt, g/hr	10.48	10.47	10.48	10.47	10.48	10.47	15.36	15.35
Steam/Hydrocarbon Ratio	0.4	0.4	0.4	0.4	0.4	0.4	0.4	0.4
Total Accountability, %	107.4	94.9	110.45	97.0	104.4	96.8	103.0	96.4
Total Products	Weight Percent							
C6+	0.22	1.42	0.43	2.18	0.64	2.79	1.13	2.86
methane	1.90	6.41	2.67	8.04	3.69	8.80	17.69	17.36
ethane	46.36	39.94	38.75	33.77	32.15	26.82	2.27	2.55
ethylene	44.89	44.89	51.27	48.53	55.63	53.41	29.85	30.83
propane	0.08	0.18	0.09	0.18	0.10	0.16	24.90	21.54
propylene	0.66	2.18	0.84	1.99	1.03	1.86	18.11	17.32
i-butane	0.00	0.00	0.00	0.00	0.00	0.00	0.05	0.04
n-butane	0.00	0.00	0.00	0.00	0.00	0.00	0.02	0.01
propadiene	0.41	0.26	0.37	0.22	0.31	0.19	0.08	0.06
acetylene	0.00	0.01	0.00	0.01	0.00	0.01	0.31	0.11
t-2-butene	0.00	0.00	0.00	0.00	0.00	0.00	0.00	0.00
1-butene	0.04	0.07	0.05	0.07	0.06	0.07	0.16	0.19
i-butylene	0.00	0.15	0.00	0.15	0.00	0.14	0.91	0.91
c-2-butene	0.12	0.19	0.13	0.11	0.13	0.08	0.13	0.44
i-pentane	0.59	0.05	0.04	0.06	0.05	0.06	0.14	0.14
n-pentane	0.01	0.01	0.00	0.00	0.00	0.00	0.00	0.03
1,3-butadiene	0.96	1.45	1.34	1.69	1.72	2.06	1.64	2.28
methyl acetylene	n/a	n/a	n/a	n/a	n/a	n/a	0.19	0.23
t-2-pentene	0.03	0.04	0.02	0.04	0.03	0.05	0.12	0.13
2-methyl-2-butene	0.02	0.00	0.03	0.00	0.03	0.00	0.03	0.04
1-pentene	0.00	0.00	0.00	0.00	0.00	0.00	0.11	0.02
c-2-pentene	0.03	0.04	0.03	0.04	0.03	0.03	0.01	0.06
pentadiene 1	0.00	0.00	0.00	0.00	0.00	0.00	0.00	0.00
pentadiene 2	0.00	0.00	0.00	0.00	0.00	0.00	0.01	0.02
pentadiene 3	0.00	0.00	0.00	0.00	0.00	0.00	0.14	0.17
1,3-Cyclopentadiene	0.03	0.06	0.02	0.05	0.02	0.05	0.44	0.72
pentadiene 4	0.00	0.00	0.00	0.00	0.00	0.00	0.00	0.00
pentadiene 5	0.00	0.03	0.00	0.03	0.00	0.03	0.06	0.08
CO ₂	0.00	0.00	0.00	0.00	0.00	0.00	0.00	0.00
CO	0.00	0.00	0.00	0.00	0.00	0.00	0.11	0.00
hydrogen	3.46	2.66	3.94	2.90	4.36	3.43	1.36	1.22

TABLE 10-continued

Examples of Cracking Ethane and r-pyoil at different temperatures.								
Examples	Comparative Example 5	41	Comparative Example 6	42	Comparative Example 7	43	Comparative Example 3	Comparative Example 8
unidentified	0.00	0.00	0.00	0.00	0.00	0.00	0.00	0.65
Olefin/Aromatics	216.63	34.87	126.61	24.25	91.78	20.80	45.81	18.66
Total Aromatics	0.22	1.42	0.43	2.18	0.64	2.79	1.13	2.86
Propylene + Ethylene	45.56	47.07	52.11	50.52	56.65	55.28	47.96	48.14
Ethylene/Propylene Ratio	67.53	20.59	60.95	24.44	54.13	28.66	1.65	1.78

[0511] A limited number of runs with ethane were made. As can be seen in the Comparative Examples 5-7 and Comparative Example 3, conversion of ethane to products occurred more slowly than with propane. Comparative Example 5 with ethane and Comparative Example 3 with propane were run at the same molar flow rates and temperatures. However, conversion of ethane was only 52% (100%-46% ethane in product) vs 75% for propane. However, the r-ethylene/r-propylene ratio was much higher (67.53 vs 1.65) as ethane cracking produced mainly r-ethylene. The olefin to aromatics ratio for ethane cracking was also much higher for ethane cracking. The Comparative Examples 5-7 and Examples 41-43 compare cracking ethane to an 80/20 mixture of ethane and r-pyoil at 700° C., 705° C. and 710° C. Production of total r-ethylene plus r-propylene increased with both ethane feed and the combined feed when the temperature was increased (an increase from about 46% to about 55% for both). Although the r-ethylene to r-propylene ratio decreased for ethane cracking with increasing temperature (from 67.53 at 700° C. to 60.95 at 705° C. to 54.13 at 710° C.), the ratio increased for the mixed feed (from 20.59 to 24.44 to 28.66). r-Propylene was produced from the r-pyoil and some continued to crack generating more cracked products such as r-ethylene, dienes and aromatics.

The amount of aromatics in propane cracking with r-pyoil at 700° C. (2.86% in Comparative Example 8) was about the same as cracking ethane and r-pyoil at 710° C. (2.79% in Example 43).

[0512] Co-cracking ethane and r-pyoil required higher temperature to obtain more conversion to products compared to co-cracking with propane and r-pyoil. Ethane cracking produced mainly r-ethylene. Since a high temperature was required to crack ethane, cracking a mixture of ethane and r-pyoil produced more aromatics and dienes as some r-propylene reacted further. Operation in this mode would be appropriate if aromatics and dienes were desired with minimal production of r-propylene.

Examples of Cracking r-Pyoil and Propane 5° C. Higher or Lower than Cracking Propane

[0513] Table 11 contains runs made in the lab steam cracker with propane at 695° C., 700° C., and 705° C. (Comparative examples 3, 9-10) and Examples 44-46 using 80/20 propane/r-pyoil weight ratios at these temperatures. Steam was fed to the reactor in a 0.4 steam to hydrocarbon ratio in all runs. r-Pyoil Example 2 was cracked with propane in these examples.

TABLE 11

Examples using r-Pyoil Example 2 at 700° C. +/- 5° C.						
Examples	Comparative Example 9	Comparative Example 3	Comparative Example 10	44	45	46
Zone 2 Control Temp, ° C.	695	700	705	695	700	705
Propane (wt %)	100	100	100	80	80	80
r-Pyoil Example 2 (wt %)	0	0	0	20	20	20
Zone 2 Exit Temp, ° C.	683	689	695	685	691	696
Feed Wt, g/hr	15.36	15.36	15.36	15.35	15.35	15.35
Steam/Hydrocarbon Ratio	0.4	0.4	0.4	0.4	0.4	0.4
Total Accountability, %	105	103	100.2	99.9	96.4	94.5
Total Products	Weight Percent					
C6+	0.76	1.13	1.58	2.44	2.86	4.02
methane	15.06	17.69	20.02	14.80	17.36	19.33
ethane	1.92	2.27	2.49	2.20	2.55	2.63
ethylene	25.76	29.85	33.22	27.14	30.83	33.06
propane	33.15	24.90	18.96	28.21	21.54	15.38
propylene	18.35	18.11	16.61	17.91	17.32	15.43
i-butane	0.05	0.05	0.03	0.06	0.04	0.03
n-butane	0.02	0.02	0.02	0.03	0.01	0.02
propadiene	0.07	0.08	0.10	0.10	0.06	0.12
acetylene	0.22	0.31	0.42	0.27	0.11	0.47
t-2-butene	0.00	0.00	0.00	0.00	0.00	0.00
1-butene	0.15	0.16	0.16	0.19	0.19	0.17
i-butylene	0.95	0.91	0.80	1.01	0.91	0.72
c-2-butene	0.11	0.13	0.13	0.49	0.44	0.33
i-pentane	0.12	0.14	0.13	0.15	0.14	0.12

TABLE 11-continued

Examples using r-Pyoil Example 2 at 700° C. +/- 5° C.						
Examples	Comparative Example 9	Comparative Example 3	Comparative Example 10	44	45	46
n-pentane	0.00	0.00	0.00	0.02	0.03	0.02
1,3-butadiene	1.22	1.64	2.00	1.93	2.28	2.39
methyl acetylene	0.14	0.19	0.23	0.20	0.23	0.26
t-2-pentene	0.11	0.12	0.12	0.12	0.13	0.12
2-methyl-2-butene	0.02	0.03	0.02	0.04	0.04	0.03
1-pentene	0.11	0.11	0.05	0.02	0.02	0.01
c-2-pentene	0.01	0.01	0.06	0.04	0.06	0.03
pentadiene 1	0.00	0.00	0.00	0.01	0.00	0.00
pentadiene 2	0.00	0.01	0.01	0.01	0.02	0.01
pentadiene 3	0.12	0.14	0.16	0.24	0.17	0.22
1,3-Cyclopentadiene	0.30	0.44	0.59	0.59	0.72	0.83
pentadiene 4	0.00	0.00	0.00	0.00	0.00	0.00
pentadiene 5	0.05	0.06	0.06	0.07	0.08	0.08
CO ₂	0.00	0.00	0.00	0.00	0.00	0.00
CO	0.00	0.11	0.47	0.00	0.00	0.00
hydrogen	1.21	1.36	1.50	1.09	1.22	1.32
unidentified	0.00	0.00	0.00	0.61	0.65	2.84
Olefin/Aromatics Ratio	62.38	45.81	34.23	20.43	18.66	13.33
Total Aromatics	0.76	1.13	1.58	2.44	2.86	4.02
Propylene + Ethylene	44.12	47.96	49.83	45.05	48.14	48.49
Ethylene/Propylene Ratio	1.40	1.65	2.00	1.52	1.78	2.14

[0514] Operating at a higher temperature in the propane tube gave a higher conversion of propane—mainly to r-ethylene and r-propylene (increasing from 44.12% to 47.96% to 49.83% in Comparative Example 9, 3, and 10 respectively). The higher the temperature the more r-ethylene was produced at the expense of r-propylene (r-ethylene/r-propylene ratio increased from 1.40 to 1.65 to 2.0 in Comparative Examples 9, 3, and 10). Aromatics also increased with higher temperature. The same trends were observed with cracking the mixed streams in Examples 44-46: increased r-ethylene and r-propylene from 45.05% to 48.49%), increased r-ethylene/r-propylene ratio (from 1.52 to 2.14), and an increase in total aromatics (from 2.44% to 4.02%). It is known that r-pyoil conversion to cracked products is greater at a given temperature relative to propane.

[0515] For the condition where the mixed feed has a 5° C. lower reactor outlet temperature consider the following two cases:

[0516] Case A. Comparative Example 3 (Propane at 700° C.) and Example 441 (80/20 at) 695° C.

[0517] Case B. Comparative Example 103 (Propane at 705° C.) and Example 452 (80/20 at 700° C.)

[0518] Operating the combined tube at 5° C. lower temperature allowed isolation of more r-propylene relative to the higher temperature. For example, operating at 700° C. in Example 45 vs 705° C. in Example 46, r-propylene was 17.32% vs 15.43%. Similarly, operating at 695° C. in Example 44 vs 700° C. in Example 45, r-propylene was 17.91% vs 17.32%. r-Propylene and r-ethylene yield increased as temperature was increased, but this occurred at the expense of r-propylene as shown by the increasing r-ethylene to r-propylene ratio (from 1.52 at 695° C. in Example 44 to 2.14 at 705° C. in Example 46). The ratio also increased for propane feed, but it started from a slightly lower level. Here, the ratio increased from 1.40 at 695° C. to 2.0 at 705° C.

[0519] The lower temperature in the combined tube still gave almost as good conversion to r-ethylene and r-propylene (For Case A: 47.96% for propane cracking vs 45.05%

for combined cracking and for Case B: 49.83% for propane cracking vs 48.15% combined). Operation of the combined tube at lower temperature also decreased aromatics and dienes. Thus, this mode is preferred if more r-propylene is desired relative to r-ethylene while minimizing production of C₆₊(aromatics) and dienes.

[0520] For the condition where the mixed tube has a 5° C. higher reactor outlet temperature, consider the following two cases:

[0521] Case A. Comparative Example 3 (Propane at 700° C. and Example 46 (80/20 at) 705° C.

[0522] Case B. Comparative Example 9 (Propane at 695° C.) and Example 45 (80/20 at) 700° C.

[0523] Running lower temperature in the propane tube decreased the conversion of propane and decreased the r-ethylene to r-propylene ratio. The ratio was lower at lower temperatures for both the combined feed and the propane feed cases. The r-pyoil conversion to cracked products was greater at a given temperature relative to propane. It was seen that operating 5° C. higher in the combined tube caused production of more r-ethylene and less r-propylene relative to the lower temperature. This mode—with the higher temperature in the combined tube—gave an increased conversion to r-ethylene plus r-propylene (For Case A: 47.96% for propane cracking in Comparative Example 3 vs 48.49% in Example 46 for combined cracking, and for Case B: 44.11% for propane cracking (Comparative Example 9) vs 48.15% for combined cracking (Example 45) at 5° C. higher temperature).

[0524] Operation in this mode (5° C. higher temperature in the combined tube) increases production of r-ethylene, aromatics, and dienes, if so desired. By operating the propane tube at a lower temperature—which operates at a lower ethylene to propylene ratio—the r-propylene production can be maintained compared to running both tubes at the same temperature. For example, operating the combined tube at 700° C. and the propane tube at 695° C. resulted in 18.35% and 17.32%, respectively, of r-propylene. Running both at 695° C. would give 0.6% more r-propylene in the combined

tube. Thus, this mode is preferred if more aromatics, dienes, and slightly more r-ethylene is desired while minimizing production loss of r-propylene.

[0525] The temperatures were measured at the exit of Zone 2 which is operated to simulate the radiant zone of the cracking furnace. These temperatures are shown in Table 11. Although there were considerable heat losses in operating a small lab unit, the temperatures showed that the exit temperatures for the combined feed cases were 1-2° C. higher than for the corresponding propane only feed case. Steam

Examples Feeding r-Pyoil or r-Pyoil and Steam at Various Locations

[0526] Table 12 contains runs made in the lab steam cracker with propane and r-pyoil Example 3. Steam was fed to the reactor in a 0.4 steam to hydrocarbon ratio in all runs. r-Pyoil and steam were fed at different locations (see configurations in FIG. 11). In Example 48, the reactor inlet temperature was controlled at 380° C., and r-pyoil was fed as a gas. The reactor inlet temperature was usually controlled at 130-150° C. when r-pyoil was fed as a liquid (Example 49) in the typical reactor configuration.

TABLE 12

Examples with r-Pyoil and Steam Fed at Different Locations.						
Examples*	47	48	49	50	51	52
Zone 2 Control Temp	700° C.	700° C.	700° C.	700° C.	700° C.	700° C.
Propane (wt %)	80	80	80	80	80	80
r-Pyoil (wt %)	20	20	20	20	20	20
Feed Wt, g/hr	15.33	15.33	15.33	15.33	15.33	15.33
Steam/hydrocarbon ratio	0.4	0.4	0.4	0.4	0.4	0.4
Total Accountability, %	95.8	97.1	97.83	97.33	96.5	97.3
Total Products	Weight Percent					
C6+	3.03	3.66	4.50	3.32	3.03	3.38
methane	17.37	18.49	19.33	17.46	19.85	17.38
ethane	2.58	3.04	3.27	2.60	3.18	2.35
ethylene	30.30	31.07	31.53	30.93	32.10	30.75
propane	21.90	19.10	16.57	20.11	17.79	21.96
propylene	16.82	16.78	15.97	17.24	16.64	16.14
i-butane	0.04	0.04	0.03	0.04	0.03	0.04
n-butane	0.04	0.03	0.03	0.03	0.03	0.03
propadiene	0.10	0.09	0.09	0.11	0.11	0.12
acetylene	0.35	0.33	0.33	0.36	0.34	0.40
t-2-butene	0.00	0.00	0.00	0.00	0.00	0.00
1-butene	0.19	0.19	0.19	0.19	0.18	0.18
i-butylene	0.94	0.79	0.72	0.86	0.73	0.86
c-2-butene	0.43	0.39	0.39	0.43	0.37	0.39
i-pentane	0.16	0.16	0.16	0.16	0.15	0.15
n-pentane	0.04	0.02	0.02	0.03	0.02	0.04
1,3-butadiene	2.15	2.16	2.22	2.28	2.20	2.29
methyl acetylene	0.21	0.21	0.20	0.23	0.22	0.24
t-2-pentene	0.13	0.13	0.13	0.13	0.12	0.12
2-methyl-2-butene	0.04	0.03	0.03	0.03	0.03	0.03
1-pentene	0.02	0.01	0.02	0.02	0.02	0.02
c-2-pentene	0.05	0.03	0.03	0.03	0.03	0.04
pentadiene 1	0.00	0.00	0.01	0.00	0.00	0.00
pentadiene 2	0.03	0.02	0.02	0.02	0.01	0.01
pentadiene 3	0.25	0.07	0.22	0.24	0.22	0.24
1,3-Cyclopentadiene	0.72	0.76	0.83	0.80	0.79	0.81
pentadiene 4	0.00	0.00	0.00	0.00	0.00	0.00
pentadiene 5	0.08	0.08	0.08	0.08	0.08	0.08
CO ₂	0.00	0.00	0.00	0.00	0.05	0.00
CO	0.00	0.00	0.00	0.00	0.23	0.00
hydrogen	1.24	1.23	1.23	1.21	1.42	1.25
Unidentified	0.79	1.09	1.80	1.06	0.00	0.71
Olefin/Aromatics Ratio	17.27	14.36	11.67	16.08	17.71	15.43
Total Aromatics	3.03	3.66	4.50	3.32	3.03	3.38
Propylene + Ethylene	47.12	47.85	47.50	48.17	48.75	46.89
Ethylene/Propylene Ratio	1.80	1.85	1.97	1.79	1.93	1.91

*Example 47 -r-Pyoil fed between zone 1 and zone 2: Proxy For Crossover

*Example 48- r-Pyoil and steam fed between zone 1 and zone 2: Proxy for Crossover

*Example 49- r-Pyoil and steam fed at midpoint of zone 1: Proxy for Downstream of Inlet

*Example 50- r-Pyoil fed at midpoint of zone 1: Proxy for Downstream of Inlet

*Example 51- r-Pyoil fed as gas at inlet of zone 1

*Example 49- r-Pyoil fed as liquid at inlet of zone 1

cracking is an endothermic process. There is less heat needed in cracking with pyoil and propane than when cracking propane alone, and thus the temperature does not decrease as much.

[0527] Feeding propane and r-pyoil as a gas at reactor inlet (Example 51) gave a higher conversion to r-ethylene and r-propylene compared to Example 52 where the r-pyoil was fed as a liquid. Some conversion was due to heating the

stream to near 400° C. where some cracking occurred. Since the r-pyoil was vaporized outside the reactor, no heat supplied for that purpose was required by the furnace. Thus, more heat was available for cracking. As a result, a greater amount of r-ethylene and r-propylene (48.75%) was obtained compared to that obtained when the r-pyoil was fed as a liquid at the top of the reactor (46.89% in Example 52). Additionally, r-pyoil entering the reactor as a gas decreased residence time in the reactor which resulted in lower total aromatics and an increased olefin/aromatics ratio for Example 51.

[0528] In the other examples (47-50) either r-pyoil or r-pyoil and steam was fed at the simulated crossover between the convection zone and the radiant zone of a steam cracking furnace (between Zone 1 and Zone 2 of the lab furnace) or at the mid-point of Zone 1. There was little difference in the cracking results except for the aromatic content in Example 49. Feeding r-pyoil and steam at the midpoint of Zone 1 resulted in the greatest amount of aromatics. The number of aromatics was also high when steam was cofed with r-pyoil between Zone 1 and Zone 2 (Example 48). Both examples had a longer overall residence time for propane to react before the streams were combined compared to the other Examples in the table. Thus, the particular combination of longer residence time for cracking propane and a slightly shorter residence time for r-pyoil cracking in Example 49 resulted in a greater amount of aromatics as cracked products.

[0529] Feeding r-pyoil as a liquid at the top of reactor (Example 52) gave the lowest conversion of all the conditions. This was due to the r-pyoil requiring vaporization which needed heat. The lower temperature in Zone 1 resulted in less cracking when compared to Example 51.

[0530] Higher conversion to r-ethylene and r-propylene was obtained by feeding the r-pyoil at the crossover or the midpoint of the convection section for one main reason. The propane residence time in the top of the bed—before introduction of r-pyoil or r-pyoil and steam—was lower. Thus, propane can achieve higher conversion to r-ethylene and r-propylene relative to Example 52 with a 0.5 sec residence time for the entire feed stream. Feeding propane and r-pyoil as a gas at reactor inlet (Example 51) gave the highest conversion to r-ethylene and r-propylene because none of the furnace heat was used in vaporization of r-pyoil as was required for the other examples.

Decoking Examples from Cracking r-Pyoil Example 5 with Propane or Natural Gasoline.

[0531] Propane was cracked at the same temperature and feed rate as an 80/20 mixture of propane and r-pyoil from Example 5 and an 80/20 mixture of natural gasoline and r-pyoil from Example 5. All examples were operated in the same way. The examples were run with a Zone 2 control temperature of 700° C. When the reactor was at stable temperature, propane was cracked for 100 minutes, followed by 4.5 hr of cracking propane, or propane and r-pyoil, or natural gasoline and r-pyoil, followed by another 60 min of propane cracking. The steam/hydrocarbon ratio was varied in these comparative examples from 0.1 to 0.4. The propane cracking results are shown in Table 13 as Comparative Examples 11-13. The results presented in Table 14 include examples (Examples 53-58) involving cracking an 80/20 mixture of propane or natural gasoline with r-pyoil from Example 5 at different steam to hydrocarbon ratios. Nitrogen (5% by weight relative to the hydrocarbon) was fed with

steam in the examples with natural gasoline and r-pyoil to provide even steam generation. In the examples involving cracking r-pyoil with natural gasoline, the liquid samples were not analyzed. Rather, the measured reactor effluent gas flow rate and gas chromatography analysis were used to calculate the theoretical weight of unidentified material for 100% accountability.

[0532] Following each steam cracking run, decoking of the reactor tube was performed. Decoking involved heating all three zones of the furnace to 700° C. under 200 sccm N2 flow and 124 sccm steam. Then, 110 sccm air was introduced to bring the oxygen concentration to 5%. Then, the air flow was slowly increased to 310 sccm as the nitrogen flow was decreased over two hours. Next, the furnace temperature was increased to 825° C. over two hours. These conditions were maintained for 5 hours. Gas chromatography analysis were performed every 15 minutes beginning with the introduction of the air stream. The amount of carbon was calculated based on the amount of CO2 and CO in each analysis. The amount of carbon was totalized until no CO was observed, and the amount of CO2 was less than 0.05%. The results (mg carbon by gas chromatography analysis) from decoking the propane comparative examples are found in Table 13. The results from the r-pyoil examples is found in Table 14.

TABLE 13

Comparative Examples of Cracking with Propane.			
	Examples		
	Comparative Example 11	Comparative Example 12	Comparative Example 13
Zone 2 Control Temp, ° C.	700° C.	700° C.	700° C.
Propane (wt %)	100	100	100
r-Pyoil (wt %)	0	0	0
N2 (wt %)	0	0	0
Feed Wt, g/hr	15.36	15.36	15.36
Steam/Hydrocarbon Ratio	0.1	0.2	0.4
Total Accountability, %	98.71	101.30	99.96
Total Products	Weight Percent		
C6+	1.71	1.44	1.10
Methane	20.34	19.92	17.98
Ethane	3.04	2.83	2.25
Ethylene	32.48	32.29	30.43
Propane	19.04	20.26	24.89
Propylene	17.72	17.88	18.19
i-butane	0.04	0.04	0.04
n-butane	0.03	0.00	0.00
Propadiene	0.08	0.04	0.04
Acetylene	0.31	0.03	0.04
t-2-butene	0.00	0.00	0.00
1-butene	0.18	0.18	0.17
i-butylene	0.78	0.82	0.93
c-2-butene	0.15	0.14	0.13
i-pentane	0.15	0.15	0.14
n-pentane	0.00	0.00	0.00
1,3-butadiene	1.93	1.90	1.68
methyl acetylene	0.18	0.18	0.19
t-2-pentene	0.14	0.14	0.12
2-methyl-2-butene	0.03	0.03	0.03
1-pentene	0.01	0.01	0.01
c-2-pentene	0.01	0.11	0.10
pentadiene 1	0.00	0.00	0.00
pentadiene 2	0.01	0.01	0.01
pentadiene 3	0.00	0.00	0.00
1,3-Cyclopentadiene	0.17	0.16	0.14
pentadiene 4	0.00	0.00	0.00

TABLE 13-continued

Comparative Examples of Cracking with Propane.			
	Examples		
	Comparative Example 11	Comparative Example 12	Comparative Example 13
pentadiene 5	0.07	0.00	0.01
CO ₂	0.00	0.00	0.00
CO	0.00	0.00	0.00
Hydrogen	1.41	1.43	1.39
Unidentified	0.00	0.00	0.00
Olefin/Aromatics Ratio	31.53	37.20	47.31

TABLE 13-continued

Comparative Examples of Cracking with Propane.			
	Examples		
	Comparative Example 11	Comparative Example 12	Comparative Example 13
Total Aromatics	1.71	1.44	1.10
Propylene + Ethylene	50.20	50.17	48.62
Ethylene/Propylene Ratio	1.83	1.81	1.67
Carbon from Decoking, mg	16	51	1.5

TABLE 14

Examples of Cracking Propane or Natural Gasoline and r-Pyoil.						
Examples	53	54	55	56	57	58
Propane or Natural Gasoline	Propane	Propane	Propane	Nat Gas	Nat Gas	Nat Gas
Zone 2 Control Temp	700	700	700	700	700	700
Propane/Nat Gas (wt %)	80	80	80	80	80	80
r-Pyoil (wt %)	20	20	20	20	20	20
N ₂ (wt %)	0	0	0	5*	5*	5*
Feed Wt, g/hr	15.32	15.32	15.32	15.29	15.29	15.29
Steam/Hydrocarbon Ratio	0.1	0.2	0.4	0.4	0.6	0.7
Total Accountability, %	95.4	99.4	97.5	100**	100**	100**
Total Products	Weight Percent					
C6+	2.88	2.13	2.30	5.69	4.97	5.62
Methane	18.83	16.08	16.62	15.60	16.81	18.43
Ethane	3.56	2.85	2.27	2.97	3.43	3.63
Ethylene	30.38	28.17	30.20	27.71	27.74	26.94
Propane	19.81	25.60	24.07	0.40	0.43	0.36
Propylene	18.37	18.83	18.13	14.76	14.48	12.04
i-butane	0.04	0.06	0.05	0.03	0.03	0.02
n-butane	0.00	0.00	0.00	0.00	0.00	0.00
Propadiene	0.05	0.05	0.04	0.09	0.09	0.08
Acetylene	0.04	0.04	0.05	0.12	0.10	0.10
t-2-butene	0.00	0.00	0.00	0.00	0.00	0.00
1-butene	0.23	0.22	0.19	0.45	0.43	0.44
i-butylene	0.81	0.97	0.97	1.27	1.02	1.04
c-2-butene	0.63	0.76	0.55	3.38	3.31	2.94
i-pentane	0.19	0.18	0.16	0.02	0.02	0.03
n-pentane	0.01	0.01	0.04	1.27	1.12	2.08
1,3-butadiene	2.11	2.29	2.45	3.64	3.52	3.45
methyl acetylene	0.17	n/a	n/a	0.41	0.37	0.37
t-2-pentene	0.16	0.13	0.12	0.12	0.12	0.13
2-methyl-2-butene	0.03	0.03	0.03	0.05	0.06	0.09
1-pentene	0.02	0.02	0.02	0.08	0.10	0.12
c-2-pentene	0.11	0.10	0.09	0.08	0.09	0.11
pentadiene 1	0.00	0.00	0.00	0.05	0.08	0.14
pentadiene 2	0.01	0.03	0.02	0.23	0.36	0.53
pentadiene 3	0.00	0.00	0.00	0.00	0.00	0.00
1,3-Cyclopentadiene	0.26	0.26	0.25	0.50	0.55	0.58
pentadiene 4	0.00	0.00	0.00	0.00	0.00	0.00
pentadiene 5	0.09	0.08	0.08	0.00	0.00	0.12
CO ₂	0.00	0.00	0.00	0.02	0.00	0.00
CO	0.00	0.00	0.00	0.06	0.06	0.03
Hydrogen	1.21	1.12	1.24	0.96	0.95	0.95
Unidentified	0.00	0.00	0.00	20.04	19.77	19.63
Olefin/Aromatics Ratio	18.48	24.43	23.07	9.22	10.46	8.67
Total Aromatics	2.88	2.13	2.30	5.69	4.97	5.62
Propylene + Ethylene	48.75	47.00	48.33	42.47	42.22	38.98
Ethylene/Propylene Ratio	1.65	1.50	1.67	1.88	1.92	2.24
Carbon from Decoking, mg	96	44	32	90	71	23

*5% N₂ was also added to facilitate steam generation. Analysis has been normalized to exclude it.

**100% accountability based on actual reactor effluent gas flow rate and gas chromatography analysis and calculation to give theoretical mass of unidentified products.

[0533] The cracking results showed the same general trends that were seen in the other cases, such as r-propylene and r-ethylene yield and total aromatics increasing with a lower steam to hydrocarbon ratio due to the longer residence time in the reactor. These runs were made to determine the amount of carbon generated when a r-pyoil was cracked with propane or natural gasoline. These were short runs but they were sufficiently accurate to see trends in coking. Cracking propane produced the least coking. The carbon produced ranged from 16 to 51 mg at 0.2 or less steam/hydrocarbon ratio. Coking was the smallest at a 0.4 steam/hydrocarbon ratio. In fact, only 1.5 mg of carbon was determined after decoking in Comparative 13. A much longer run time is needed to improve accuracy. Since most commercial plants operate at a steam to hydrocarbon ratio of 0.3 or higher, the 51 mg obtained at 0.2 ratio may not be unreasonable and may be considered a baseline for other feeds. For the r-pyoil/propane feed in Examples 53-55, increasing the ratio from 0.1 to 0.2 to 0.4 decreased the amount of carbon obtained from 96 mg (Example 53) to 32 mg (Example 55). Even the 44 mg of carbon at a 0.2 ratio (Example 54) was not unreasonable. Thus, using a 0.4 ratio for the combined r-pyoil and propane feed inhibited coke formation similar to using a 0.2-0.4 ratio for propane. Cracking r-pyoil with natural gasoline required a 0.7 ratio (Example 58) to decrease the carbon obtained to the 20-50 mg range. At a 0.6 ratio, (Example 57) 71 mg of carbon was still obtained. Thus, operation of an 80/20 mixture of natural gasoline and r-pyoil should use a ratio of 0.7 or greater to provide runtimes typical for operation of propane cracking.

[0534] Increasing the steam to hydrocarbon ratio decreased the amount of coke formed in cracking propane, propane and r-pyoil, and natural gasoline and r-pyoil. A higher ratio was required as a heavier feedstock was cracked. Thus, propane required the lowest ratio to obtain low coke formation. Cracking propane and r-pyoil required a ratio of about 0.4. A range of 0.4 to 0.6 would be adequate to allow typical commercial runtimes between decoking. For the natural gasoline and r-pyoil mixture, even a higher ratio was required. In this case, a ratio of 0.7 or above is needed. Thus, operating at a steam to hydrocarbon ratio of 0.7 to 0.9 would be adequate to allow typical commercial runtimes between decoking.

Example 59—Plant Test

[0535] About 13,000 gallons from tank **1012** of r-pyoil were used in the plant test as show in FIG. 12. The furnace coil outlet temperature was controlled either by the testing coil (Coil-A **1034a** or Coil-B **1034b**) outlet temperature or by the propane coil (Coil C **1034c**, coil D **1034d** through F) outlet temperature, depending on the objective of the test. In FIG. 12 the steam cracking system with r-pyoil **1010**; **1012** is the r-pyoil tank; **1020** is the r-pyoil tank pump; **1024a** and **1226b** are TLE (transfer line exchanger); **1030a, b, c** is the furnace convection section; **1034a, b, c, d** are the coils in furnace firebox (the radiant section); **1050** is the r-pyoil transfer line; **1052a, b** are the r-pyoil feed that is added into the system; **1054a, b, c, d** are the regular hydrocarbon feed; **1058a, b, c, d**—are dilution steam; **1060a** and **1060b** are cracked effluent. The furnace effluent is quenched, cooled to ambient temperature and separated out condensed liquid, the gas portion is sampled and analyzed by gas chromatograph.

[0536] For the testing coils, propane flow **1054a** and **1054b** were controlled and measured independently. Steam flow **1058a** and **1058b** were either controlled by Steam/HC ratio controller or in an AUTO mode at a constant flow, depending on the objective of the test. In the non-testing coils, the propane flow was controlled in AUTO mode and steam flow was controlled in a ratio controller at Steam/Propane=0.3.

[0537] r-pyoil was obtained from tank **1012** through r-pyoil flow meters and flow control valves into propane vapor lines, from where r-pyoil flowed along with propane into the convection section of the furnace and further down into the radiant section also called the firebox. FIG. 12 shows the process flow.

[0538] The r-pyoil properties are shown in and Table 15 and FIG. 23. The r-pyoil contained a small amount of aromatics, less than 8 wt %, but a lot of alkanes (more than 50%), thus making this material as a preferred feedstock for steam cracking to light olefins. However, the r-pyoil had a wide distillation range, from initial boiling point of about 40° C. to an end point of about 400° C., as shown in Table 15 and FIGS. 24 and 25, covering a wide range of carbon numbers (C₄ to C₃₀ as shown in Table 15). Another good characteristic of this r-pyoil is its low sulfur content of less than 100 ppm, but the r-pyoil had high nitrogen (327 ppm) and chlorine (201 ppm) content. The composition of the r-pyoil by gas chromatography analysis is shown in Table 16.

TABLE 15

Properties of r-pyoil for plant test.	
Physical Properties	
Density, 22.1° C., g/ml	0.768
Viscosity, 22.1 C., cP	1.26
Initial Boiling Point, ° C.	45
Flash Point, ° C.	Below -1.1
Pour Point, ° C.	-5.5
Impurities	
Nitrogen, ppmw	327
Sulfur, ppmw	74
Chlorine, ppmw	201
Hydrocarbons, wt %	
Total Identified alkanes	58.8
Total Identified Aromatics	7.2
Total Identified Olefins	16.7
Total Identified Dienes	1.1
Total Identified Hydrocarbons	83.5

TABLE 16

r-Pyoil composition.							
Component	wt % Component	wt % Component	wt % Component	wt % Component	wt % Component	wt %	
Propane	0.17	2,4-dimethylheptene	1.52	C12-Alkane	3.21	C19-Alkane	1.81
1,3-Butadiene	0.97	2,4-dimethylheptane	3.98	C13-Alkene	1.19	C20-Alkene	0.25
Pentene	0.40	Ethylbenzene	3.07	C13-Alkane	2.91	C20-Alkane	1.53
Pentane	3.13	m,p-xylene	0.66	2-methylnaphthalene	0.62	C21-Alkene	0.00
2-methyl-Pentene	2.14	Styrene	1.11	C14-Alkene	0.83	C21-Alkane	1.28
2-methyl-Pentane	2.46	Mol. Weight = 140	1.73	C14-Alkane	3.02	C22-Alkane	1.10
Hexane	1.83	Nonane	2.81	acenaphthalene	0.19	C23-Alkane	0.87
2,4-dimethylpentene	0.20	Cumene	0.96	C15-alkene	0.86	C24-Alkane	0.72
Benzene	0.17	Decene/methylstyrene	1.16	C15-alkane	3.00	C25-Alkane	0.57
5-methyl-1,3-cyclopentadiene	0.17	Decane	3.16	C16-Alkene	0.58	C26-Alkane	0.47
Heptene	1.15	Indene	0.20	C16-Alkane	2.56	C27-Alkane	0.36
Heptane	2.87	Indane	0.26	C17-Alkene	0.46	c28-Alkane	0.28
Toluene	1.07	C11-Alkene	1.31	C17-Alkene	2.42	c29-Alkane	0.22
4-methylheptane	1.65	C11-Alkane	3.29	C18-Alkene	0.32	C30-Alkane	0.17
Octene	1.51	Napthalene	0.00	C18-Alkane	2.10	Total Identified	83.5%
Octane	2.77	C12-Alkene	1.29	C19-Alkene	0.37		

[0539] Before the plant test started, eight (8) furnace conditions (more specifically speaking, eight conditions on the testing coils) were chosen. These included r-pyoil content, coil outlet temperature, total hydrocarbon feeding rate, and the ratio of steam to total hydrocarbon. The test plan, objective and furnace control strategy are shown in Table 17. “Float Mode” means the testing coil outlet temperature is not controlling the furnace fuel supply. The furnace fuel supply is controlled by the non-testing coil outlet temperature, or the coils that do not contain r-pyoil.

TABLE 17

Plan for the plant test of r-pyoil co-cracking with propane.								
Con- dition	COT, ° F.	Pyoil w %	Py/ C ₃ H ₈	TOTAL, KLB/HR	Pyoil/ coil, GPM	Pyoil/ coil, lb/hr	Stm/ HC ratio	Pro- pane/ coil, klb/hr
Base- line	1500	0	0.000	6.0	0.00	0	0.3	6.00
1A	Float	5	0.053	6.0	0.79	300	0.3	5.70
1B	Float	10	0.111	6.0	1.58	600	0.3	5.40
1C & 2A	Float	15	0.176	6.0	2.36	900	0.3	5.10
2B	Lower by at least 10 F. than the base- line	15	0.176	6.0	2.36	900	0.3	5.10
3A & 2C	1500	15	0.176	6.0	2.36	900	0.3	5.10
3B	1500	15	0.176	6.9	2.72	1035	0.3	5.87
4A	1500	15	0.176	6.0	2.36	900	0.4	5.10
4B	1500	15	0.176	6.0	2.36	900	0.5	5.10
5A	Float	4.8	0.050	6.3	0.79	300	0.3	6.00
5B	At 2B COT	4.8	0.050	6.3	0.79	302	0.3	6.00

[0540] The results of r-Pyoil addition can be observed differently depending on how propane flow, steam/HC ratio and furnace are controlled. Temperatures at crossover and

coil outlet changed differently depending on how propane flow and steam flow are maintained and how the furnace (the fuel supply to the firebox) was controlled. There were six coils in the testing furnace. There were several ways to control the furnace temperature via the fuel supply to the firebox. One of them was to control the furnace temperature by an individual coil outlet temperature, which was used in the test. Both a testing coil and a non-testing coil were used to control the furnace temperature for different test conditions.

Example 59.1—at Fixed Propane Flow, Steam/HC Ratio and Furnace Fuel Supply (Condition 5A)

[0541] In order to check the r-pyoil 1052a addition effect, propane flow and steam/HC ratio were held constant, and furnace temperature was set to control by a non-testing coil (Coil-C) outlet temperature. Then r-pyoil 1052a, in liquid form, without preheating, was added into the propane line at about 5% by weight.

[0542] Temperature changes: After the r-pyoil 1052a addition, the crossover temperature dropped about 10° F. for A and B coil, COT dropped by about 7° F. as shown in Table 18. There are two reasons that the crossover and COT temperature dropped. One, there was more total flow in the testing coils due to r-pyoil 1052a addition, and two, r-pyoil 1052a evaporation from liquid to vapor in the coils at the convection section needed more heat thus dropping the temperature down. With a lower coil inlet temperature at the radiant section, the COT also dropped. The TLE exit temperature went up due to a higher total mass flow through the TLE on the process side.

[0543] Cracked gas composition change: As can be seen from the results in Table 18, methane and r-ethylene decreased by about 1.7 and 2.1 percentage points, respectively, while r-propylene and propane increased by 0.5 and 3.0 percentage points, respectively. The propylene concentration increased as did the propylene:ethylene ratio relative to the baseline of no pyoil addition. This was the case even though the propane concentration also increased. Others did not change much. The change in r-ethylene and methane was due to the lower propane conversion at the higher flow rate, which was shown by a much higher propane content in the cracked gas.

TABLE 18

Changes When Hydrocarbon Mass Flow Increases By Adding r-pyoil To Propane At 5% At Constant Propane Flow, Steam/HC Ratio And Firebox Condition.			
	Base-line	Base-line	5A Add in Pyoil
A&B Propane flow, klb/hr	11.87	11.86	11.85
A&B Pyoil Flow, lb/hr	0	0	593
A&B Steam flow, lb/hr	3562	3556	3737
A&B total HC flow, klb/hr	11.87	11.86	12.44
Pyoil/(poil + propane), %	0.0	0.0	4.8
Steam/HC, ratio	0.30	0.30	0.30
A&B Crossover T, F	1092	1091	1081
A&B COT, F	1499	1499	1492
A&B TLE Exit T, F	691	691	698
A&B TLE Inlet, PSIG	10.0	10.0	10.0
A&B TLE Exit T, PSIG	9.0	9.0	9.0
<hr/>			
Cracked Gas Product	wt %	wt %	wt %
Hydrogen	1.26	1.39	1.29
Methane	18.83	18.89	17.15
Ethane	4.57	4.54	4.38
Ethylene	31.25	31.11	28.94
Acetylene	0.04	0.04	0.04
Propane	20.13	21.25	24.15
Propylene	17.60	17.88	18.36
MAPD	0.26	0.25	0.25
Butanes	0.11	0.12	0.15
Butadiene	1.73	1.67	1.65
Butenes + CPD	1.41	1.41	1.62
Other C5s	0.42	0.37	0.40
C6s+	1.34	0.93	1.55
CO2	0.046	0.022	0.007
CO	1.001	0.134	0.061
Aver. M.W.	24.5	24.2	25.1

Example 59.2 at Fixed Total HC Flow, Steam/HC Ratio and Furnace Fuel Supply (Conditions 1A, 1B, & 1C)

[0544] In order to check how the temperatures and crack gas composition changed when the total mass of hydrocarbons to the coil was held constant while the percent of r-pyoil 1052a in the coil varied, steam flow to the testing coil was held constant in AUTO mode, and the furnace was set to control by a non-testing coil (Coil-C) outlet temp to allow the testing coils to be in Float Mode. The r-pyoil 1052a, in liquid form, without preheating, was added into propane line at about 5, 10 and 15% by weight, respectively. When r-pyoil 1052a flow was increased, propane flow was decreased accordingly to maintain the same total mass flow of hydrocarbon to the coil. Steam/HC ratio was maintained at 0.30 by a constant steam flow.

[0545] Temperature Change: As the r-pyoil 1052a content increased to 15%, crossover temperature dropped modestly by about 5°F, COT increased greatly by about 15°F, and TLE exit temperature just slightly increased by about 3°F, as shown in Table 19.

[0546] Cracked gas composition change: As r-pyoil 1052a content in the feed increased to 15%, methane, ethane, r-ethylene, r-butadiene and benzene in cracked gas all went up by about 0.5, 0.2, 2.0, 0.5, and 0.6 percentage points, respectively. r-Ethylene/r-propylene ratio went up. Propane dropped significantly by about 3.0 percentage points, but r-propylene did not change much, as shown in Table 19A. These results showed the propane conversion increased. The increased propane conversion was due to the higher COT. When the total hydrocarbon feed to coil, steam/HC ratio and furnace fuel supply are held constant, the COT should go down when crossover temperature drops. However, what was seen in this test was opposite. The crossover temperature declined but COT went up, as shown in Table 19a. This indicates that r-pyoil 1052a cracking does not need as much heat as propane cracking on the same mass basis.

TABLE 19A

Variation of R-pyoil content and its effect on cracked gas and temperatures (Steam/HC ratio and furnace firebox were held constant).								
	Base-line	Base-line	1A, 5% Pyoil	1A, 5% Pyoil	1B, 10% Pyoil	1B, 10% Pyoil	1C, 15% Pyoil	1C, 15% pyoil
A&B Propane flow, klb/hr	11.87	11.86	11.25	11.25	10.66	10.68	10.06	10.07
A&B Pyoil Flow, lb/hr	0	0	537	536	1074	1074	1776	1778
A&B Steam flow, lb/hr	3562	3556	3544	3543	3523	3523	3562	3560
A&B total HC flow, klb/hr	11.87	11.86	11.79	11.78	11.74	11.75	11.84	11.85
Pyoil/(poil + propane), %	0.0	0.0	4.6	4.6	9.2	9.1	15.0	15.0
Steam/HC, ratio	0.30	0.30	0.30	0.30	0.30	0.30	0.30	0.30
A&B Crossover T, F.	1092	1091	1092	1092	1090	1090	1088	1087
A&B COT, F.	1499	1499	1503	1503	1509	1509	1514	1514
A&B TLE Exit T, F.	691	691	692	692	692	692	693	693
A&B TLE Inlet, PSIG	10.0	10.0	10.5	10.5	10.0	10.0	10.0	10.0
A&B TLE Exit T, PSIG	9.0	9.0	9.0	9.0	9.0	9.0	9.0	9.0
<hr/>								
Cracked Gas Product	wt %	wt %	wt %	wt %	wt %	wt %	wt %	wt %
Hydrogen	1.26	1.39	1.40	1.32	1.33	1.28	1.31	1.18
Methane	18.83	18.89	18.96	18.74	19.31	19.08	19.61	19.16
Ethane	4.57	4.54	4.59	4.69	4.70	4.81	4.67	4.85
Ethylene	31.25	31.11	31.52	31.62	32.50	32.63	33.06	33.15
Acetylene	0.04	0.04	0.04	0.04	0.05	0.05	0.05	0.05
Propane	20.13	21.25	20.00	19.95	18.58	18.65	16.97	17.54
Propylene	17.60	17.88	17.85	17.86	17.79	17.85	17.58	17.81
MAPD	0.26	0.25	0.27	0.27	0.29	0.29	0.30	0.30
Butanes	0.11	0.12	0.11	0.11	0.10	0.10	0.10	0.10
Butadiene	1.73	1.67	1.86	1.86	2.04	2.03	2.23	2.17
Butenes + CPD	1.41	1.41	1.52	1.52	1.59	1.57	1.67	1.65
Other C5s	0.42	0.37	0.38	0.38	0.38	0.37	0.40	0.39

TABLE 20-continued

Effect of COT on cracked gas composition. (Steam/HC ratio, R-pyoil 1052a content in the feed and total hydrocarbon mass flow were all held constant)

	1C, 15% Pyoil	1C, 15% pyoil	2B, 15% Pyoil	2B, 15% Pyoil	2C, 15% Pyoil	2C, 15% Pyoil	5A, Add in Pyoil 5% to C ₃ H ₈	5B, Pyoil 5%@low T
A&B Crossover T, F	1088	1087	1055	1059	1075	1076	1081	1062
A&B COT, F	1514	1514	1479	1479	1497	1497	1492	1478
A&B TLE Exit T, F	693	693	688	688	690	691	698	697
A&B TLE Inlet, PSIG	10.0	10.0	10.0	10.0	10.0	10.0	10.0	10.0
A&B TLE Exit T, PSIG	9.0	9.0	9.0	9.0	9.0	9.0	9.0	9.0
Cracked Gas Product	wt %	wt %	wt %	wt %	wt %	wt %	wt %	wt %
Hydrogen	1.31	1.18	1.12	1.13	1.25	1.25	1.29	1.20
Methane	19.61	19.16	16.60	16.23	18.06	17.87	17.15	16.07
Ethane	4.67	4.85	4.81	4.65	4.72	4.75	4.38	4.28
Ethylene	33.06	33.15	29.33	28.51	31.03	30.73	28.94	27.37
Acetylene	0.05	0.05	0.04	0.04	0.04	0.04	0.04	0.03
Propane	16.97	17.54	24.01	25.51	21.17	21.10	24.15	27.33
Propylene	17.58	17.81	18.45	18.59	18.29	18.30	18.36	18.57
MAPD	0.30	0.30	0.27	0.25	0.27	0.28	0.25	0.23
Butanes	0.10	0.10	0.14	0.16	0.13	0.13	0.15	0.17
Butadiene	2.23	2.17	1.94	1.76	1.87	1.99	1.65	1.50
Butenes + CPD	1.67	1.65	1.65	1.73	1.71	1.77	1.62	1.63
Other C5s	0.40	0.39	0.35	0.35	0.37	0.40	0.40	0.40
C6s+	1.95	1.56	1.21	1.03	1.00	1.30	1.55	1.17
CO ₂	0.007	0.008	0.010	0.007	0.009	0.009	0.007	0.007
CO	0.086	0.084	0.065	0.054	0.070	0.072	0.061	0.047
Aver. M.W.	24.2	24.6	25.7	25.9	24.8	24.9	25.1	25.8

Example 59.5 Effect of Steam/HC Ratio (Conditions 4A & 4B)

[0551] Steam/HC ratio effect is listed in Table 21A. In this test, r-pyoil 1052a content in the feed was held constant at 15%. COT in the testing coils was held constant in SET mode, while the COTs at non-testing coils were allowed to float. Total hydrocarbon mass flow to each coil was held constant.

[0552] On temperature. When steam/HC ratio was increased from 0.3 to 0.5, the crossover temperature dropped by about 17°F since the total flow in the coils in the convection section increased due to more dilution steam, even though the COT of the testing coil was held constant. Due to the same reason, TLE exit temperature went up by about 13 F.

[0553] On cracked gas composition. In the cracked gas, methane and r-ethylene were reduced by 1.6 and 1.4 percentage points, respectively, and propane was increased by 3.7 percentage points. The increased propane in the cracked gas indicated propane conversion dropped. This was due to, firstly, a shorter residence time, since in the 4B condition, the total moles (including steam) going into the coils was about 1.3 times of that in 2° C. condition (assuming the average molecular weight of r-pyoil 1052a was 160), and secondly, to the lower crossover temperature, which was the inlet temperature for the radiant coil, making the average cracking temperature lower.

TABLE 21A

Effect of steam/HC ratio. (r-Pyoil in the HC feed at 15%, total hydrocarbon mass flow and COT were held constant).

	2C, 15% Pyoil	2C, 15% Pyoil	4A, Stm ratio 0.4	4B, Stm ratio 0.5
A&B Propane flow, klb/hr	10.07	10.06	10.08	10.08
A&B Pyoil Flow, lb/hr	1777	1776	1778	1778
A&B Steam flow, lb/hr	3560	3559	4748	5933
A&B total HC flow, klb/hr	11.84	11.84	11.85	11.85
Pyoil/(poil + propane), %	15.0	15.0	15.0	15.0
Steam/HC, ratio	0.30	0.30	0.40	0.50
A&B Crossover T, F	1075	1076	1063	1058
A&B COT, F	1497	1497	1498	1498
A&B TLE Exit T, F	690	691	698	703
A&B Feed Pres, PSIG	69.5	69.5	67.0	67.0
A&B TLE Inlet, PSIG	10.0	10.0	10.0	11.0
A&B TLE Exit T, PSIG	9.0	9.0	9.0	9.0
Cracked Gas Product	wt %	wt %	wt %	wt %
Hydrogen	1.26	1.25	0.87	1.12
Methane	18.06	17.87	16.30	16.18
Ethane	4.72	4.75	4.55	4.38
Ethylene	31.03	30.73	29.92	29.52
Acetylene	0.04	0.04	0.05	0.05
Propane	21.17	21.10	23.40	24.88
Propylene	18.29	18.30	18.67	18.49
MAPD	0.27	0.28	0.29	0.28
Butanes	0.13	0.13	0.15	0.16
Butadiene	1.87	1.99	2.01	1.85
Butenes + CPD	1.71	1.77	1.89	1.81
Other C5s	0.37	0.40	0.43	0.37
C6s+	1.00	1.30	1.38	0.84

TABLE 21A-continued

Effect of steam/HC ratio. (r-Pyoil in the HC feed at 15%, total hydrocarbon mass flow and COT were held constant).				
	2C, 15% Pyoil	2C, 15% Pyoil	4A, Stm ratio 0.4	4B, Stm ratio 0.5
CO ₂	0.009	0.009	0.026	0.008
CO	0.070	0.072	0.070	0.061

[0554] On cracked gas composition. In the cracked gas, methane and r-ethylene were reduced by 1.6 and 1.4 percentage points, respectively, and propane was increased

[0555] Renormalized cracked gas composition. In order to see what the lighter product composition could be if ethane and propane in the cracked gas would be recycled, the cracked gas composition in Table 21A was renormalized by taking off propane or ethane+propane, respectively. The resulting composition is listed in Table 21B. It can be seen, olefin (r-ethylene+r-propylene) content went up with steam/HC ratio.

TABLE 21B

Renormalized cracked gas composition. (R-pyoil in the HC feed at 15%, total hydrocarbon mass flow and COT were held constant).				
	2C, 15% Pyoil	4A, Stm ratio 0.4	4B, Stm ratio 0.5	
A&B Propane, flow, klb/hr	10.07	10.08	10.08	
Pyoil/(poil + propane), %	15.0	15.0	15.0	
Steam/HC, ratio	0.30	0.40	0.50	
A&B Crossover T, F	1075	1063	1058	
A&B COT, F	1497	1498	1498	
Renorm. w/o Propane	wt %	wt %	wt %	
Hydrogen	1.60	1.14	1.49	
Methane	22.91	21.28	21.54	
Ethane	5.99	5.94	5.83	
Ethylene	39.36	39.06	39.29	
Acetylene	0.05	0.06	0.06	
Propylene	23.21	24.37	24.62	
MAPD	0.34	0.38	0.38	
Butanes	0.17	0.20	0.21	
Butadiene	2.37	2.63	2.46	
Butenes + CPD	2.16	2.47	2.41	
Other C5s	0.46	0.56	0.50	
C6s+	1.27	1.80	1.12	
CO ₂	0.011	0.033	0.010	
CO	0.089	0.091	0.081	
C ₂ H ₄ + C ₃ H ₆	62.57	63.43	63.91	
Renorm. w/o C ₂ H ₆ + C ₃ H ₈	wt %	wt %	wt %	
Hydrogen	1.70	1.21	1.58	
Methane	24.37	22.62	22.87	
Ethylene	41.87	41.52	41.73	
Acetylene	0.06	0.06	0.06	
Propylene	24.69	25.91	26.15	
MAPD	0.36	0.40	0.40	
Butanes	0.18	0.21	0.22	
Butadiene	2.52	2.79	2.61	
Butenes + CPD	2.30	2.62	2.55	
Other C5s	0.49	0.60	0.53	
C6s+	1.35	1.91	1.19	
CO ₂	0.012	0.035	0.011	
CO	0.094	0.097	0.086	
C ₂ H ₄ + C ₃ H ₆	66.55	67.43	67.87	

[0556] Effect of total hydrocarbon feed flow (Conditions 2C & 3B) An increase in total hydrocarbon flow to the coil

means a higher throughput but a shorter residence time, which reduces conversion. With r-pyoil **1052a** at 15% in the HC feed, a 10% increase of the total HC feed brought about a slight increase in the propylene:ethylene ratio along with an increase in the concentration of propane without a change in ethane, when COT was held constant. Other changes were seen on methane and r-ethylene. Each dropped about 0.5–0.8 percentage points. The results are listed in Table 22.

TABLE 22

Comparison of more feed to coil (Steam/HC ratio = 0.3, COT is held constant at 1497F).				
	2C, 15% Pyoil	2C, 15% Pyoil	3B, 10% more FD	3B, 10% more FD
A&B Propane flow, klb/hr	10.07	10.06	11.09	11.09
A&B Pyoil Flow, lb/hr	1777	1776	1956	1957
A&B Steam flow, lb/hr	3560	3559	3916	3916
A&B total HC flow, klb/hr	11.84	11.84	13.04	13.05
Pyoil/(poil + propane), %	15.0	15.0	15.0	15.0
Steam/HC, ratio	0.30	0.30	0.30	0.30
A&B Crossover T, F	1075	1076	1066	1065
A&B COT, F	1497	1497	1497	1497
A&B TLE Exit T, F	690	691	698	699
A&B TLE Inlet, PSIG	10.0	10.0	10.3	10.3
A&B TLE Exit T, PSIG	9.0	9.0	9.0	9.0
Cracked Gas Product	wt %	wt %	wt %	wt %
Hydrogen	1.26	1.25	1.19	1.24
Methane	18.06	17.87	17.23	17.31
Ethane	4.72	4.75	4.76	4.79
Ethylene	31.03	30.73	30.02	29.95
Acetylene	0.04	0.04	0.04	0.04
Propane	21.17	21.10	22.51	22.31
Propylene	18.29	18.30	18.44	18.28
MAPD	0.27	0.28	0.28	0.28
Butanes	0.13	0.13	0.15	0.14
Butadiene	1.87	1.99	1.93	1.95
Butenes + CPD	1.71	1.77	1.82	1.82
Other C5s	0.37	0.40	0.41	0.42
C6s+	1.00	1.30	1.15	1.39
CO ₂	0.009	0.009	0.009	0.008
CO	0.070	0.072	0.065	0.066

[0557] r-pyoil **1052a** is successfully co-cracked with propane in the same coil on a commercial scale furnace.

What is claimed is:

1. A cracker feedstock composition comprising a recycle content pyrolysis oil composition (r-pyoil), wherein said r-pyoil is present in said feedstock in an amount of 1% to 20% by weight, based on the total weight of the feedstock; wherein at least 50 weight percent of said r-pyoil is obtained from the pyrolysis of recycled waste plastic; wherein said composition is suitable for use in a thermal steam cracking of alkanes to alkenes.

2. The composition of claim 1, wherein at least 60 weight percent of said r-pyoil is obtained from the pyrolysis of recycled waste plastic.

3. The composition of claim 2, wherein at least 95 weight percent of said r-pyoil is obtained from the pyrolysis of recycled waste.

4. The composition of claim 3, wherein said recycled waste comprises waste plastics, waste textiles, waste carpet fibers, waste modified cellulose, waste biomass, post-industrial waste streams, intermediate industrial waste streams, or combinations thereof.

5. The composition of claim 4, wherein at least 70 weight percent of said r-pyoil is obtained from the pyrolysis of waste plastic.

6. The composition of claim 1, wherein said cracker feedstock has not been hydrotreated.

7. The composition of claim 1, wherein said r-pyoil is present in said cracker feedstock in an amount of from 10% to 20% by weight percent.

8. The composition of claim 7, wherein said cracker feedstock composition comprises at least 60 weight percent and/or not more than 100 weight percent of non-recycle C5 to C22 hydrocarbons.

9. The composition of claim 8, wherein said cracker feedstock has a final boiling point of not more than 360° C. and/or at least 200, ° C.

10. The composition of claim 9, wherein not more than 25 weight percent of the cracker feedstock has a boiling point of 300° C. or more.

11. The composition of claim 10, wherein at least 0.5 weight percent of said cracker feedstock has a boiling point of 300° C. or more.

12. The composition of claim 11, wherein said cracker feedstock has a total C15+ content of not more than 25 weight percent, based on the total weight of the stream.

13. The composition of claim 12, wherein said cracker feedstock has a total C15+ content of at least 0.5 weight percent, based on the total weight of the stream.

14. The composition of claim 13, wherein said cracker feedstock has a total chlorine content of not more than 20 ppm.

15. The composition of claim 14, wherein said cracker feedstock has a total chlorine content of at least 0.25 ppm.

16. The composition of claim 15, wherein said r-pyoil comprises not more than about 30 weight percent total aromatics, based on the total weight of said r-pyoil.

17. The composition of claim 16, wherein said r-pyoil comprises at least 1 weight percent of total aromatics, based on the total weight of said r-pyoil.

18. The composition of claim 17, wherein said r-pyoil comprises at least 15 weight percent and/or not more than 80 weight percent of paraffins, based on the total weight of said r-pyoil.

19. The composition of claim 18, wherein said cracker feedstock comprises not more than about 15 weight percent of oxygen-containing hydrocarbons.

20. A method for making one or more olefins, comprising:

(a) combining a recycle content pyrolysis oil composition (r-pyoil) with a non-recycle C5 to C22 hydrocarbon stream to form a cracker feed stream, wherein said r-pyoil is present in said cracker feed stream in an amount of 5% to 20% by weight; wherein at least 50 of said r-pyoil is obtained from the pyrolysis of recycled waste plastic; and wherein said cracker feed stream is suitable for use in a thermal steam cracking of alkanes to alkenes; and

(b) cracking said cracker feed stream in a cracker furnace to provide an olefin-containing effluent stream.

* * * * *