

(19) World Intellectual Property
Organization
International Bureau



(43) International Publication Date
20 January 2005 (20.01.2005)

PCT

(10) International Publication Number
WO 2005/005247 A1

(51) International Patent Classification⁷: **B63H 9/10**

PH, PL, PT, RO, RU, SC, SD, SE, SG, SK, SL, SY, TJ, TM, TN, TR, TT, TZ, UA, UG, US, UZ, VC, VN, YU, ZA, ZM, ZW.

(21) International Application Number:
PCT/EP2004/006428

(22) International Filing Date: 11 June 2004 (11.06.2004)

(25) Filing Language: English

(26) Publication Language: English

(30) Priority Data:
03425432.6 1 July 2003 (01.07.2003) EP

(84) Designated States (*unless otherwise indicated, for every kind of regional protection available*): ARIPO (BW, GH, GM, KE, LS, MW, MZ, NA, SD, SL, SZ, TZ, UG, ZM, ZW), Eurasian (AM, AZ, BY, KG, KZ, MD, RU, TJ, TM), European (AT, BE, BG, CH, CY, CZ, DE, DK, EE, ES, FI, FR, GB, GR, HU, IE, IT, LU, MC, NL, PL, PT, RO, SE, SI, SK, TR), OAPI (BF, BJ, CF, CG, CI, CM, GA, GN, GQ, GW, ML, MR, NE, SN, TD, TG).

(71) Applicant and
(72) Inventor: **RAIMONDO, Antonio** [IT/IT]; Via Mercadante 8, I-20124 Milano (IT).

Declaration under Rule 4.17:
— *of inventorship (Rule 4.17(iv)) for US only*

(81) Designated States (*unless otherwise indicated, for every kind of national protection available*): AE, AG, AL, AM, AT, AU, AZ, BA, BB, BG, BR, BW, BY, BZ, CA, CH, CN, CO, CR, CU, CZ, DE, DK, DM, DZ, EC, EE, EG, ES, FI, GB, GD, GE, GH, GM, HR, HU, ID, IL, IN, IS, JP, KE, KG, KP, KR, KZ, LC, LK, LR, LS, LT, LU, LV, MA, MD, MG, MK, MN, MW, MX, MZ, NA, NI, NO, NZ, OM, PG,

Published:
— *with international search report*
— *before the expiration of the time limit for amending the claims and to be republished in the event of receipt of amendments*

For two-letter codes and other abbreviations, refer to the "Guidance Notes on Codes and Abbreviations" appearing at the beginning of each regular issue of the PCT Gazette.

(54) Title: BOOM VANG FOR SAILBOATS

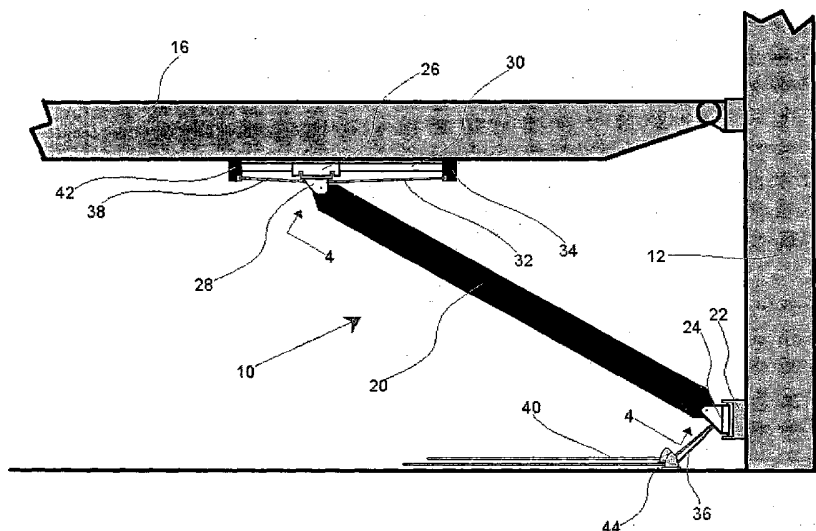

(57) Abstract: A vang assembly for manipulating a sailboat boom which is hingedly connected to the lower portion of a sailboat mast (12). The vang assembly includes a rigid and unextensive vang (strut) (20) connected both to the mast (12) and to the boom. The first end portion is hingedly attached to the lower portion of the mast below the boom, and the second end portion is hingedly attached to a traveller (26) sliding on track (30) fixed to the boom at a location spaced outwardly from the lower portion of the mast. Traveller fore and aft movements are controlled by block and tackle system. Traveller sliding allows to control boom vertical position. When traveller is pulled forward (toward the mast), the boom is forced upwardly by rigid vang working as a strut, when traveller is pulled aftward (opposite the mast), boom is forced downward by the rigid vang working as a tie rod.

WO 2005/005247 A1

TITLE

Boom vang for sailboats

FIELD OF INVENTION

[0001] This invention relates to a vang assembly for controlling the boom of a sailboat.

BACKGROUND OF THE INVENTION

[0002] A vang is an adjustable device fitted to the underside of a boom to control the raising or lowering of the boom.

Vangs typology can be divided into two basic types: soft vang and mechanical vang. The most widely used vang, in particular for smaller boat are soft vang. A typical soft vang includes a multiple purchase block and tackle system including two or more blocks or pulleys attached to the boom, and a single line having one end secured to one of the pulley systems, with the line having a free end which is pulled out and released manually by the sailor. A soft vang increases sail efficiency by pulling down on the boom in medium or heavy air, thereby increasing the tension in the leech and reducing the spill of wind.

[0003] Soft vang can only be used to pull down the boom. Thus, in slight winds or when docked, a wire or rope topping lift must be used to support the boom. Use of a topping lift is extremely undesirable because it increases the wind drag of the sailboat.

Mechanical vang represent an improvement over soft vang in that they may both pull down on the boom and hold up the boom, thus eliminating the need for a wire or rope topping lift. There are four basic varieties of mechanical vang.

[0004] The first variety is a tackle-equipped rigid vang. These vang generally comprise a set of telescoping spring-loaded aluminum tubes with a tackle rigging longitudinally associated therewith. When the tackle rigging is tightened, it applies a downward force on the boom and compresses the spring within the telescoping aluminum tubes. As the rigging is loosened, the spring within the telescoping aluminum tubes extends, thus providing support for the boom. Typically, the spring comprises a steel coil; however, compressed-gas cylinder springs are also used.

[0005] A second variety of mechanical vang are screwdriven or "rotary" vang. In a screw-driven vang, a large turnbuckle is lengthened or shortened by turning a wheel or a pair of handles in the middle of the turnbuckle. Although capable of providing both tension in the leech and supporting the boom, screw-driven vang have the serious disadvantage of being difficult and slow to adjust because of their heavy nature.

[0006] A third variety of mechanical vang are hydraulic vang. Hydraulic vang typically consist of a cylinder filled with hydraulic oil and a piston. A hydraulic pump controlled from the cockpit actuates the piston inward or outward to control the height of the boom.

[0007] The fourth variety of mechanical vang are flexible column actuated vang. This type of vang is actuated with a device that is capable of being moved between a contracted position and an extended position. When the adjustment mechanism is

moved to a contracted position, the column is forced to bow arcuately to an arched position and the boom is forced in a downward direction. When the adjustment mechanism is released to extended position, the arcuately bowed column straightens and exerts forces pushing the boom upwardly.

[0008] Mechanical vang systems have several serious problems. For the first three types, the telescoping tubes must be carefully maintained to avoid corrosion. In addition, if water is allowed to leak into the telescoping tubes, the metal springs may be particularly subject to corrosion. The telescoping springloaded tubes of these vangs must also be carefully machined, making them relatively expensive. Finally, these vangs are susceptible to denting and bending from transverse forces. Such damage inhibits the telescoping of the tubes, degrading the vang's performance. The fourth type of mechanical vang does not give a lower limit to the boom movement, making some mainsail operation difficult. Moreover first and fourth mechanical vang type have the serious limitation that the boom hold up control come from a constant elastic force that always needs pull down tackle rigging in force to maintain the boom at the desired level even in slight wind or when docked.

[0009] For these reasons there is an unresolved need in the art of boom vang system to have a simpler and lighter mechanism with high boom control performance.

OBJECT OF THE INVENTION

[0010] It is an object of the invention to provide a vang system made of a rigid and unextensible strut hingedly attached to the mast and hingedly attached to a traveller sliding on a boom fixed track.

SUMMARY OF THE INVENTION

[0011] The present invention comprises a vang assembly for manipulating a sailboat boom which is hingedly connected to the lower portion of a sailboat mast. The vang assembly includes a rigid and unextensible vang (strut) connected both to the mast and to the boom. The first end portion is hingedly attached to the lower portion of the mast below the boom, and the second end portion is hingedly attached to a traveller sliding on track fixed to the boom at a location spaced outwardly from the lower portion of the mast. Traveller fore and aft movements are controlled by block and tackle system.

[0012] Traveller sliding allows to control boom vertical position. When traveller is pulled forward (toward the mast), the boom is forced upwardly by rigid vang working as a strut, when traveller is pulled aftward (opposite the mast), boom is forced downward by the rigid vang working as a tie rod.

[0013] A simpler configuration of the system includes traveller forward movement control

only and therefore the upward boom forcing control. In this case the downward boom forcing control is made by a block and tackle traditional vang.

[0014] The boom vang system of the invention completely eliminates the problems above referred to the other mechanical system, in particular avoids any complex mechanical part, such as spring, telescopic pipe, hydraulic pump etc. and therefore avoids necessity of maintenance.

[0015] Boom control is made by a track and traveller system that is a well known extremely reliable and absolutely durable system. The rigid strut made by aluminium, composites or other materials is a strong, light and durable (no maintenance) component of the system.

[0016] Up and down boom control can be easily performed also without tension to the pull down tackle rigging in particular in light wind or when docked. All the mainsail operation become very easy.

One of the most important advantage of this system, particularly appreciated by racing boat, is the saving of weight with respect to other mechanical system. Another significant advantage is the possibility to easily use special strut section profile to reduce wind drag.

[0017] The above brief description sets forth rather broadly the more important features and advantages of the present disclosure so that the detailed description that follows may be better understood, and so that the present contributions to the art may be better appreciated. There are, of course, additional features of the disclosure that will be described hereinafter which will form the subject matter of the claims appended hereto. In this respect, before explaining the embodiment of the disclosure in detail, it is to be understood that the disclosure is not limited in its application to the details of the construction and the arrangements set forth in the following description or illustrated in the drawings. The present invention is capable of other embodiments and of being practiced and carried out in various ways, as will be appreciated by those skilled in the art. Also, it is to be understood that the phraseology and terminology employed herein are for description and not limitation.

BRIEF DESCRIPTION OF THE DRAWINGS

[0018]

FIG. 1 is a side elevational view illustrating a first embodiment of the mechanical vang of the present invention disposed between the mast and the boom of a sailboat.

FIG. 2 is a sectional side plan view of the strut (20) of FIG.1 showing inside pulling down rigging.

FIG. 3 is a sectional side plan view of the strut (20) of FIG.1 showing inside hold up rigging.

FIG. 4 is a plan of strut 20, with an inside view, along the line 4-4 of FIG. 1.

FIG. 5 is a sectional view along the line 5-5 of FIG. 4

FIG. 6 is a side view of an additional embodiment of the mechanical vang of the present invention.

FIG. 7 is a side view of an additional embodiment of the mechanical vang of the present invention.

DESCRIPTION OF THE PREFERRED EMBODIMENTS

[0019] A vang assembly, generally designated 10, of the present invention is shown in FIG. 1 positioned between a lower portion of a mast 12 and a boom 16 of a sailboat. The vang assembly broadly includes a rigid strut, generally designated 20, hingedly connected to the mast 12 with a tang 22 via hinge 24 and hingedly connected to a traveller 26 via hinge 28. The traveller 26 is sliding on a track 30 fixed below the boom 16. This embodiment includes an hollow strut 20 made by aluminium or composite material pipe. Sliding traveller 26 is controlled in his forward and aft movements by two rigging systems.

[0020] To pull traveller 26 forward (toward the mast), forcing boom upwardly, a block and tackle system (better described in FIG. 3) inside the hollow strut 20 is provided. This block and tackle system (better described in FIG. 3) ends with ropes 32 and 40. Rope 32 is coming out from the high end of strut 20 and is attached to the forward end 34 of the track 30, rope 40 is coming out from the the low end of strut 20 and, through blocks 44, is carried in a proper position in the boat where a clam cleat or similar fixing device can be positioned. Rope 40 is a dynamic type to work as boom shock absorber.

[0021] To pull traveller 26 aftward (opposite the mast), forcing boom downward, a block

and tackle system (better described in FIG. 2) inside the hollow strut 20 is provided. This block and tackle system (better described in FIG. 2) ends with ropes 38 and 36. Rope or wire 38 is coming out from the high end of strut 20 and is attached to the aft end 42 of the track 30, rope 36 is coming out from the low end of the strut 20 and trought blocks 44 is carried in a proper position in the boat where a clam cleat or similar fixing device can be positioned.

[0022] FIG 2 is the sectional plan, viewing inside, of hollow strut 20, described above, with the representation, generally designated 50 of the block and tackle system foreseen for aftward pulling (opposite the mast) of traveller 26. Rope or wire 38 is attached to the aft end 42 of track 30, going inside hollow strut 20 trought pulley 54, and is attached to pulley 57. Rope 58 is attached to pulley 55, reeves into pulley 57 and is attached to pulley 56. Rope 36 is attached to pulley 55, reeves into pulley 56 and 55, going out from low end of strut 20, and trought block 44 is carried in a proper position in the boat where a clam cleat or similar fixing device can be positioned. Pulleys 54 and 55 are hinged with pins to the high and to the low end of strut 20, while pulley 56 and 57 are free to move inside hollow strut 20. Rigging system made by ropes 38, 58 and 36 and pulleys 54, 55,56 and 57 provides a mechanical advantage. As will be appreciated by those knowledgeable in the art, there are other well known block and tackle system that can be used for the same purpose of the present invention.

[0023] FIG. 3 is the sectional plan, viewing inside of hollow strut 20, described above, with the representation, generally designated 60, of the block and tackle system foreseen for forward pulling (toward the mast) of traveller 26. Rope 32 is attached to forward end 34 of track 30, going inside hollow strut 20 trought pulley 62 and is attached to pulley 63. Rope 40 is attached to pulley 64, reeves into pulley 63 and 64, going out from low end of strut 20, and trought block 44 is carried in a proper position in the boat where a clam cleat or similar fixing device can be positioned. Pulleys 62 and 64 are hinged with pins to the high and to the low part of strut 20, while pulley 63 is free to move inside hollow strut 20. Rigging system made by ropes 32 and 40 and blocks 62 63 and 64 provide a mechanical advantage. As will be appreciated by those knowledgeable in the art, there are other well known block and tackle system that can be used for the same purpose of the present invention.

[0024] FIG. 4 provide a plan (view 4-4 of FIG.1) with an inside view of strut 20. This view shows both the boom pulling up system, formed by pulley 63, 64, 62 and rope 32, 40, and boom pulling down system, formed by pulley 54,55,56,57 and rope 36,38,58. Pulley 56,57 and 63 are free to move inside the hollow strut 20. Pulley 54 and 62 are hinged together with strut 20 and hinge 28 via pin 21; pulley 55 and 64 are hinged together with strut 20 and hinge 24 via pin 23.

For this embodiment a strut with wing contour type section profile has been used (see FIG.5) for wind drag reduction.

It is understood that, even if, this profile is a preferred choice for wind drag reduction, every other suitable profile section could be used.

FIG. 5 is section view 5-5 of FIG. 4, showing the internal space of strut 20 foreseen for the movement of pulley systems. In this section pulley 57 and 63 can be seen.

[0025] In addition to that above described, there is another embodiment, generally described 100 in FIG. 6, where strut 120 doesn't foresee inside space for block and tackle. Strut 120 can be made by aluminium or composite material and in comparison with strut 20 of FIG. 1 is thinner giving less wind drag and less production costs. This vang assembly broadly includes a rigid strut 120 hingedly connected to the mast 112 with a tang 122 via hinge 124 and hingedly connected to a traveller 126 via hinge 128. The traveller 126 is sliding on a track 130 fixed below the boom 116.

Sliding traveller 126 is controlled in his forward and aft movements by two rigging system.

[0026] To pull traveller 126 forward (toward the mast), forcing boom upwardly, a block 150 and a rope 152 are provided. Rope 152 is attached to forward end 134 of track 130, reeves into blocks 150, 170 and 180 going in a proper position where a fixing device can be installed. Rope 152 is a dynamic type to work as boom shock absorber. Rope 152 and block 150 provide a mechanical advantage. As will be appreciated by those knowledgeable in the art, there are other well known block and tackle system that can be used for the same purpose.

[0027] To pull traveller 126 aftward (opposite the mast), forcing boom downward, a block and tackle system 160 is provided. A rope 163 is reeved between block 161 and 162 for providing mechanical advantage between the two blocks. A first free end of rope 163 passes through a pulley fixed in the aft end 142 of track 130, going forward inside the hollow track 130 and through blocks 170 and 180 going in a proper position where a fixing device can be installed. A second free end of rope 163 is attached to either block 161 or block 162. As will be appreciated by those knowledgeable in the art, there are other well known block and tackle system that can be used for the same purpose.

[0028] In addition to that above described, there is another embodiment, generally described 200 in FIG. 7, where strut 220 doesn't foresee inside space for block and tackle. Strut 220 can be made by aluminium or composite material and in comparison with strut 120 of FIG. 6 it has only the boom upwardly control leaving downwardly boom control to a traditional soft block and tackle system 270. This vang assembly broadly includes a rigid strut, generally designated 220, hingedly connected to the mast 212 with a tang 222 via hinge 240 and hingedly connected to a traveller 226 via hinge 228. The traveller 226 is sliding on a track 230 fixed below the boom 216. Sliding traveller 226 is controlled in his forward movement by a rigging system.

[0029] To pull traveller 126 forward (toward the mast), forcing boom upwardly, a block 250 and a rope 252 are provided. Rope 252 is attached to forward end 234 of track 230, reeves into block 250, going to a cam cleat 254 for pulling. Rope 252 is a dynamic type to work as boom shock absorber. Rope 252 and block 250 provide a mechanical advantage. Rope 252 can be also carried in a proper position of the boat where a fixing device can be installed. As will be appreciated by those knowledgeable in the art, there

are other well known block and tackle system that can be used for the same purpose.

[0030] For downward boom control a soft standard vang 270 is installed. A rope 278 is reeved between block 272 and 276 for providing mechanical advantage between the two blocks. A first free end of rope 278 passes through cam cleat 276 for pulling. Rope 278 can be also carried in a proper position of the boat where a fixing device can be installed. A second free end of rope 278 is attached to either block 272 or block 276.

As will be appreciated by those knowledgeable in the art, there are other well known block and tackle system that can be used for the same purpose.

[0031] While preferred embodiments and example configurations have been shown, it is to be understood that various further modifications and additional configurations will be apparent to those skilled in the art. It is intended that the specific embodiments and configurations herein disclosed are illustrative of the preferred and best modes for practicing the invention, and should not be interpreted as limitations on the scope of the invention as defined by the appended claims.

CLAIMS

1. A vang assembly (10) for manipulating a sailboat boom (16) in which a supporting part is hingedly connectable to the lower portion of a sailboat mast (12) with first end portion hingedly attachable to the lower portion of the mast (12) below the boom, and the second end portion hingedly attached to a traveller (26) sliding on track (30) fixable to the boom (16) at a location spaced outwardly from the lower portion of the mast (12), characterized in that:
said supporting part is a rigid unextensible strut (20) and
said traveller (26) fore and aft movements are controlled by adjustment means.
Adjustment means to pull traveller (26) forward (toward the mast), so to force boom (16) upwardly and to pull traveller (26) aftward (opposite the mast), so to force boom (16) downward.
2. A vang assembly as specified in claim 1 in which the rigid unextensible strut is an hollow profile.
3. A vang assembly as specified in claim 2 in which the adjustment means are block and tackle assemblies, positioned inside the hollow strut.
4. A vang assembly as specified in claim 3 in which for block and tackle system that pull traveller forward (toward the mast) a dynamic type rope is used.
5. A vang assembly as specified in claim 2 in which the strut is made with a wing contour type section profile to reduce wind drag.
6. A vang assembly as specified in claim 1 in which the adjustment means are block and tackle assemblies attached to the traveller and to the aft end and forward end of track.
7. A vang assembly as specified in claim 6 in which an hollow track allow aftward pulling rope to return toward the mast passing inside the track.
8. A vang assembly as specified in claim 6 in which for block and tackle system that pull traveller forward (toward the mast) a dynamic type rope is used.
9. A vang assembly as specified in claim 6 in which the strut is made with a wing contour type section profile to reduce wind drag
10. A vang assembly (200) for manipulating a sailboat boom (216) comprising a soft

block and tackle vang (270) independently connectable both to the boom (216) and to the mast (212) to force boom (216) downward and a supporting part with first end portion hingedly attachable to the lower portion of the mast (212) below the boom, and the second end portion hingedly attached to a traveller (226) sliding on track (230) fixable to the boom (216) at a location spaced outwardly from the lower portion of the mast (212), characterized in that:

said supporting part is a rigid unextensible strut (220) and

said traveller (226) fore movements are controlled by adjustment means.

Adjustment means to pull traveller (226) forward (toward the mast), so to force boom (216) upwardly.

11. A vang assembly as specified in claim 10 in which the adjustment means to control traveller in forward movement (toward the mast) is a block and tackle assembly.
12. A vang assembly as specified in claim 10 in which for block and tackle system that pull traveller forward (toward the mast) a dynamic type rope is used.
13. A vang assembly as specified in claim 10 in which the strut is made with a wing contour type section profile to reduce wind drag.

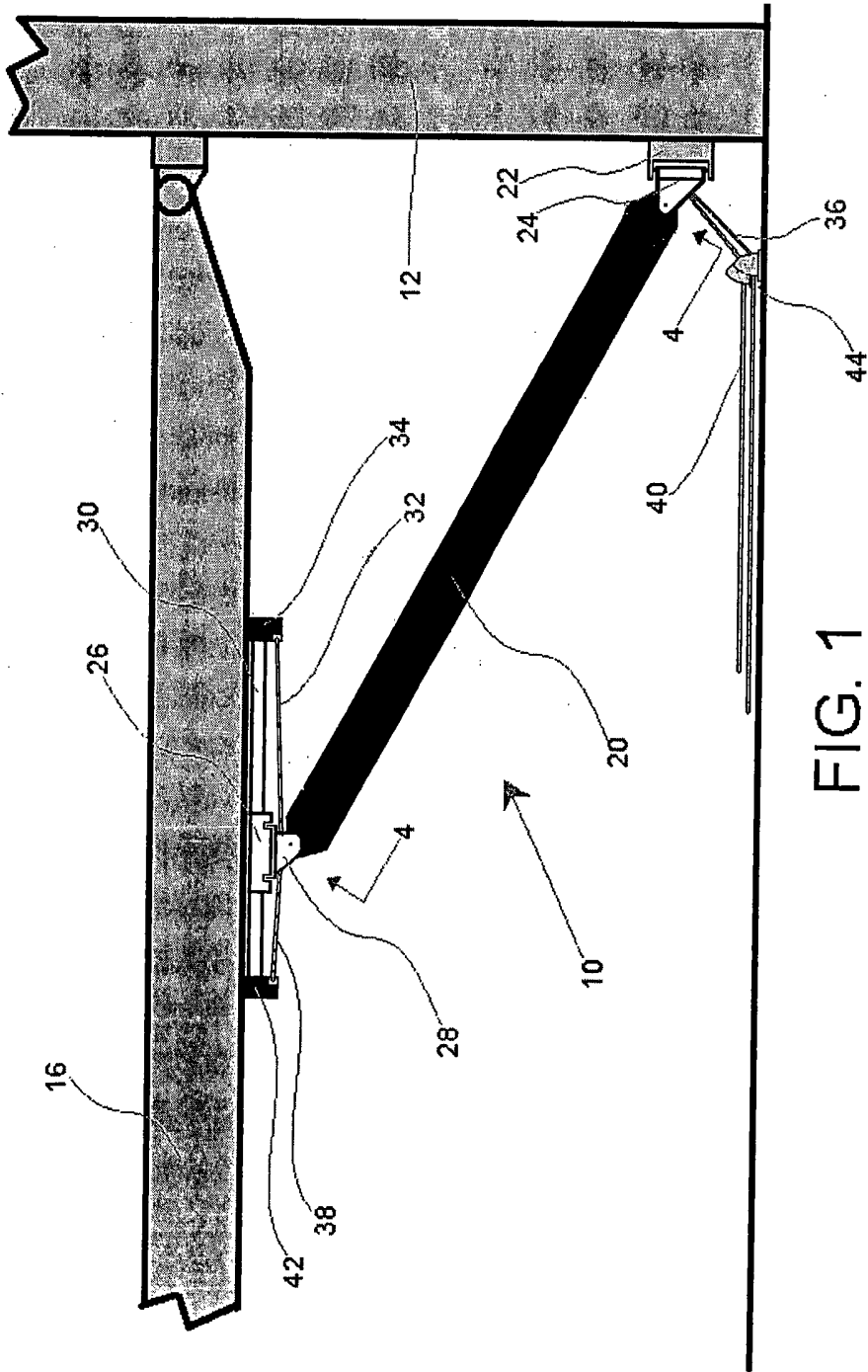

FIG. 1

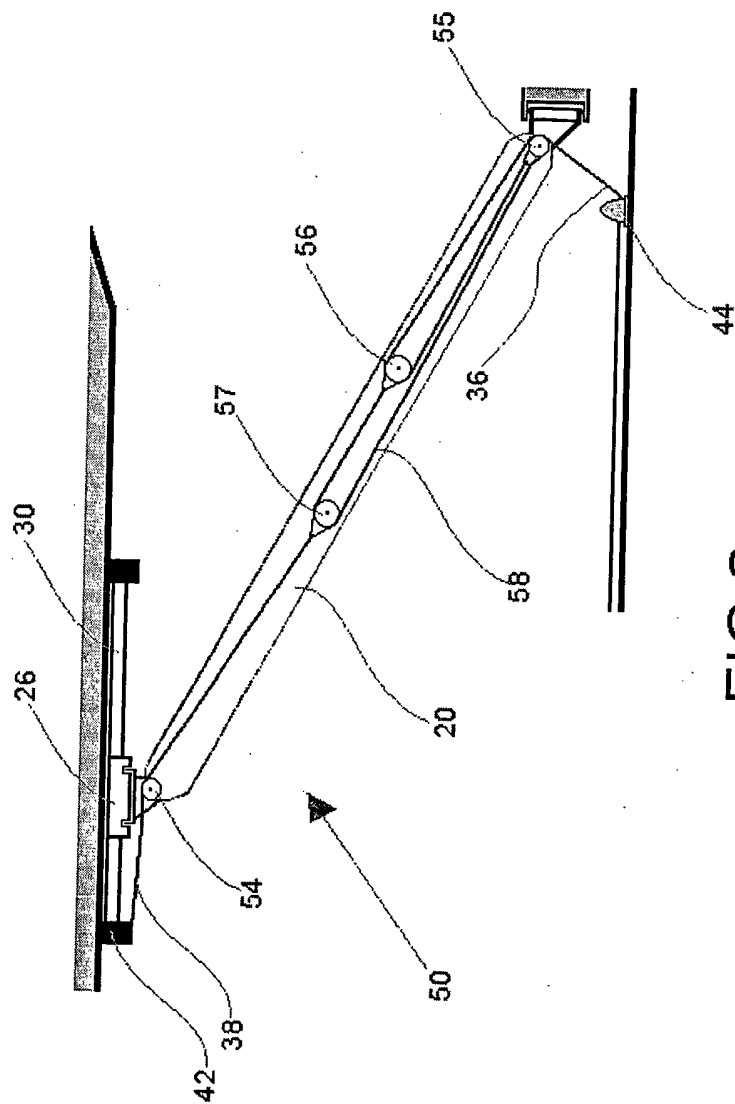

FIG.2

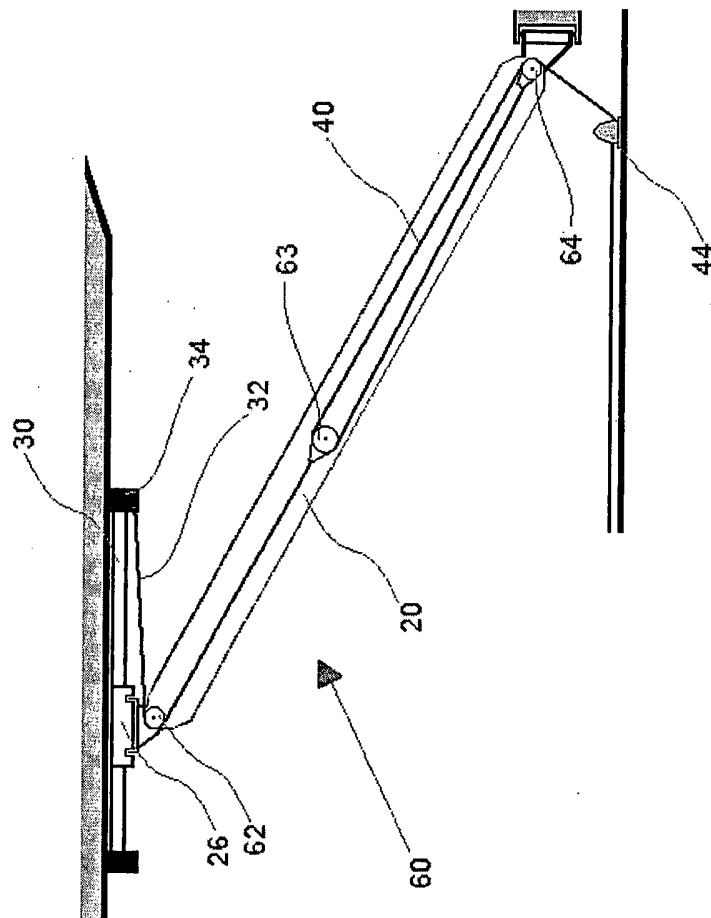

FIG. 3

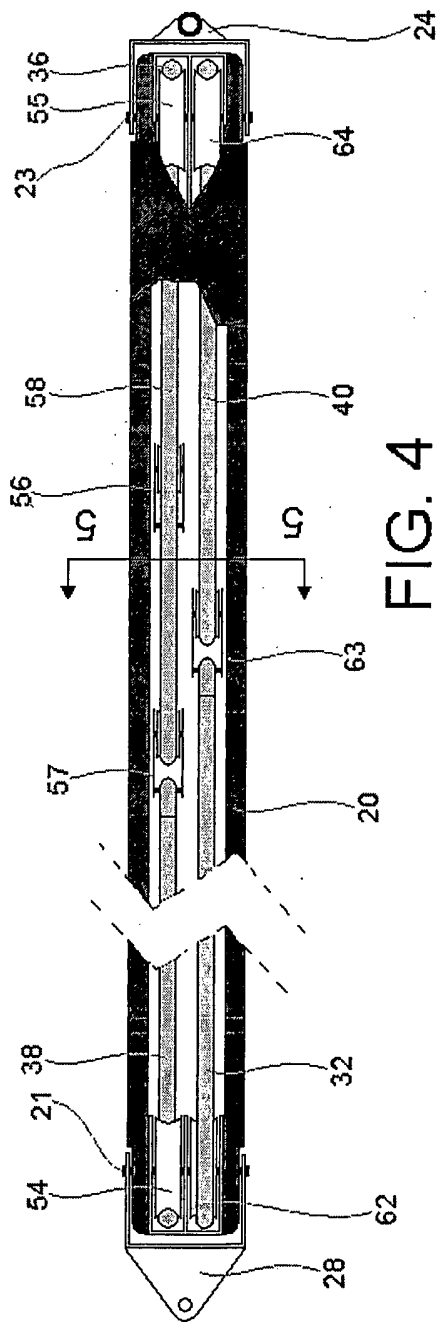

FIG. 4

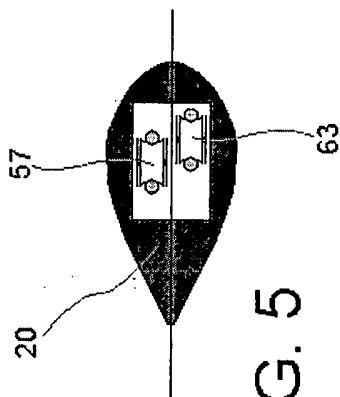

FIG. 5

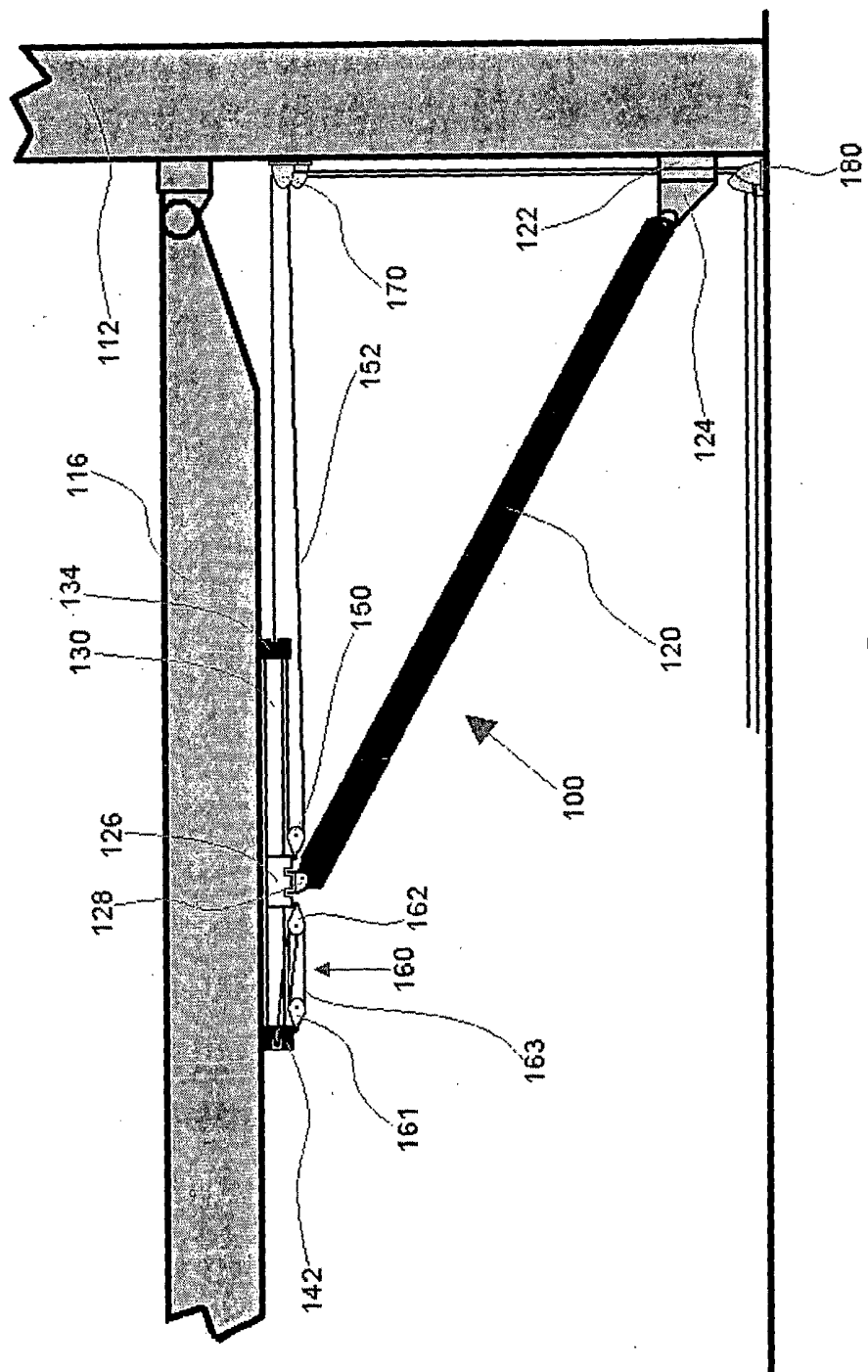

FIG. 6

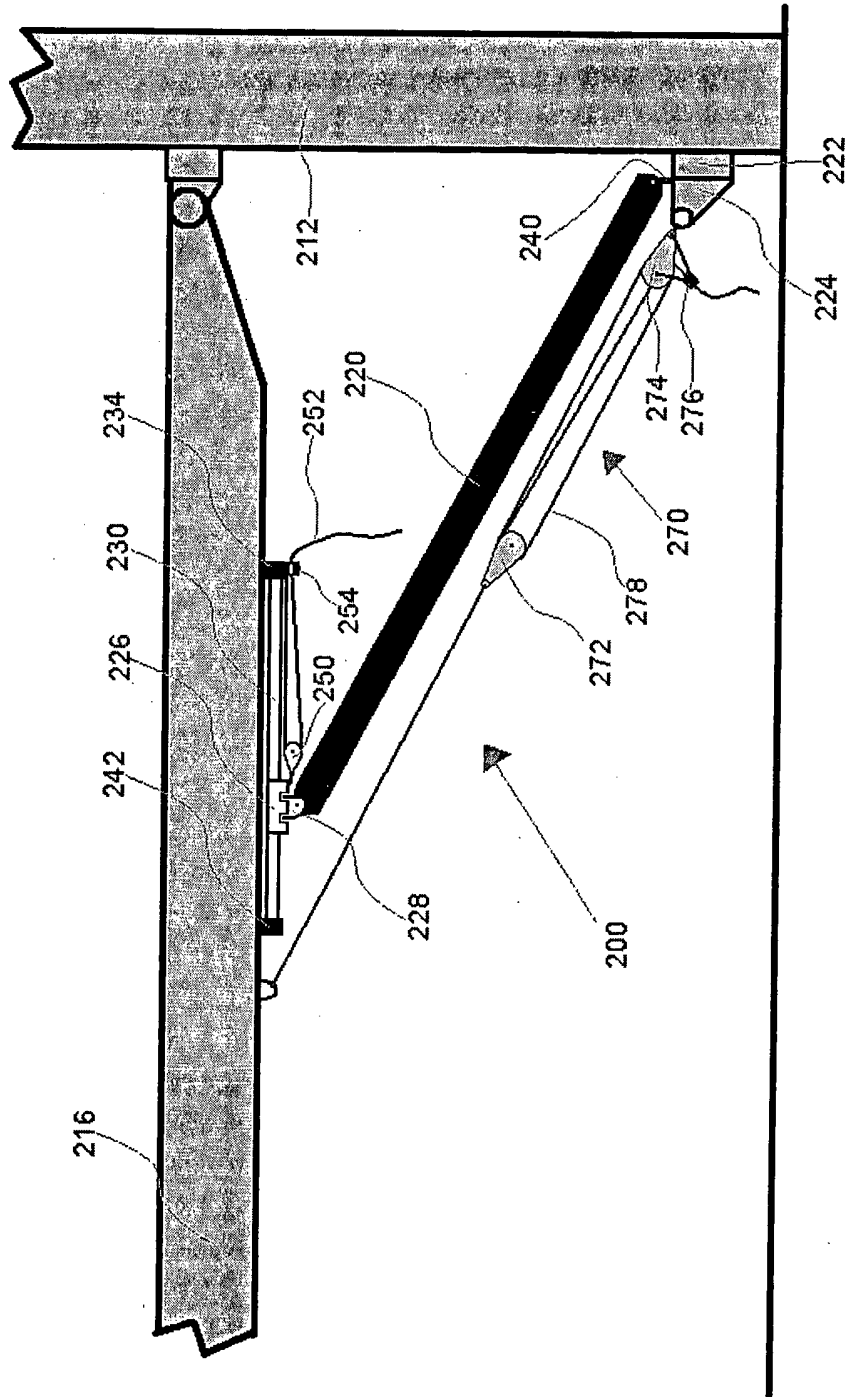

FIG. 7

INTERNATIONAL SEARCH REPORT

International Application No
PCT/EP2004/006428

A. CLASSIFICATION OF SUBJECT MATTER IPC 7 B63H9/10		
According to International Patent Classification (IPC) or to both national classification and IPC		
B. FIELDS SEARCHED		
Minimum documentation searched (classification system followed by classification symbols) IPC 7 B63H		
Documentation searched other than minimum documentation to the extent that such documents are included in the fields searched		
Electronic data base consulted during the international search (name of data base and, where practical, search terms used) EPO-Internal		
C. DOCUMENTS CONSIDERED TO BE RELEVANT		
Category °	Citation of document, with indication, where appropriate, of the relevant passages	Relevant to claim No.
A	US 4 406 240 A (ANDERSEN HELGE B) 27 September 1983 (1983-09-27) column 3, line 12 - line 22; figure 1 -----	1,10
A	US 5 115 752 A (MITCHELL ANDREW) 26 May 1992 (1992-05-26) column 2, line 31 - line 56; figures 1,2 -----	1,10
<input type="checkbox"/> Further documents are listed in the continuation of box C. <input checked="" type="checkbox"/> Patent family members are listed in annex.		
° Special categories of cited documents :		
"A" document defining the general state of the art which is not considered to be of particular relevance "E" earlier document but published on or after the international filing date "L" document which may throw doubts on priority claim(s) or which is cited to establish the publication date of another citation or other special reason (as specified) "O" document referring to an oral disclosure, use, exhibition or other means "P" document published prior to the international filing date but later than the priority date claimed		"T" later document published after the international filing date or priority date and not in conflict with the application but cited to understand the principle or theory underlying the invention "X" document of particular relevance; the claimed invention cannot be considered novel or cannot be considered to involve an inventive step when the document is taken alone "Y" document of particular relevance; the claimed invention cannot be considered to involve an inventive step when the document is combined with one or more other such documents, such combination being obvious to a person skilled in the art. "&" document member of the same patent family
Date of the actual completion of the international search 24 November 2004		Date of mailing of the international search report 01/12/2004
Name and mailing address of the ISA European Patent Office, P.B. 5818 Patentlaan 2 NL - 2280 HV Rijswijk Tel. (+31-70) 340-2040, Tx. 31 651 epo nl, Fax: (+31-70) 340-3016		Authorized officer DE SENA HERNANDORENA

INTERNATIONAL SEARCH REPORT

Information on patent family members

International Application No

PCT/EP2004/006428

Patent document cited in search report		Publication date	Patent family member(s)	Publication date
US 4406240	A	27-09-1983	DK 335679 A	14-11-1980
			AU 539331 B2	20-09-1984
			AU 6221680 A	03-03-1981
			CA 1134210 A1	26-10-1982
			DE 3049780 T0	04-03-1982
			DE 8034995 U1	16-06-1982
			WO 8100388 A1	19-02-1981
			EP 0033331 A1	12-08-1981
			FI 802460 A	11-02-1981
			GB 2071594 A ,B	23-09-1981
			IT 1132376 B	02-07-1986
			NL 8020287 A	01-07-1981
			NZ 194546 A	18-11-1983
			SE 422186 B	22-02-1982
			SE 8102245 A	08-04-1981
US 5115752	A	26-05-1992	GB 2237546 A	08-05-1991
			FR 2653740 A1	03-05-1991