



(19) **United States**

(12) **Patent Application Publication**
Chung

(10) **Pub. No.: US 2003/0168905 A1**

(43) **Pub. Date: Sep. 11, 2003**

(54) **INDEPENDENTLY ROTATING WHEELS**

Publication Classification

(76) Inventor: **I-Chao Chung, Troy, MI (US)**

(51) **Int. Cl.⁷ B60B 11/00**

(52) **U.S. Cl. 301/36.2**

Correspondence Address:

CARLSON, GASKEY & OLDS, P.C.
400 WEST MAPLE ROAD
SUITE 350
BIRMINGHAM, MI 48009 (US)

(57) **ABSTRACT**

A wheel end assembly having a dual wheel configuration includes independently rotating wheel hubs to reduce tire wear. Each wheel hub is supported on an axle spindle via a bearing member. Another bearing member is mounted between the wheel hubs to allow each wheel hub to rotate independently from the other. A fastening assembly retains the hubs on the spindle to prevent linear movement along the spindle.

(21) Appl. No.: **10/091,630**

(22) Filed: **Mar. 6, 2002**

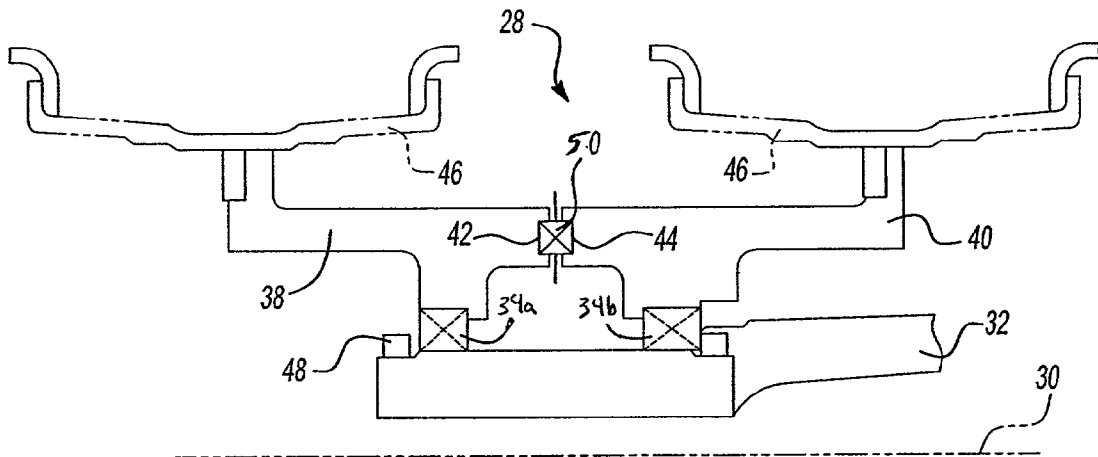

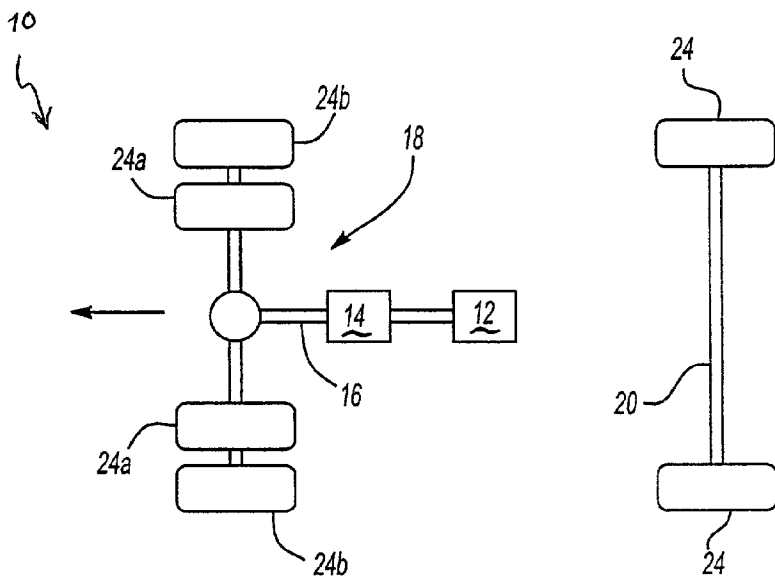

Fig-1A

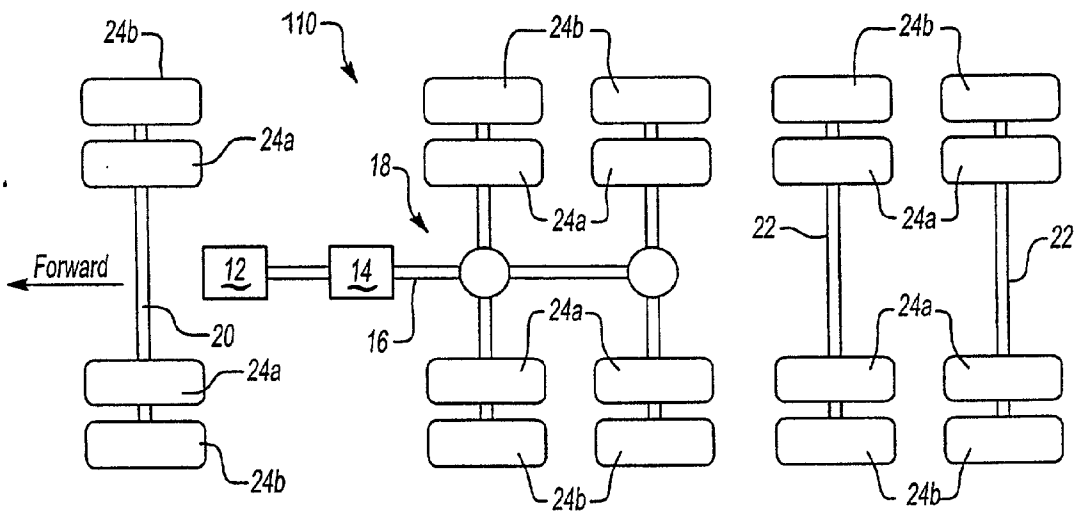

Fig-1B

Fig-2

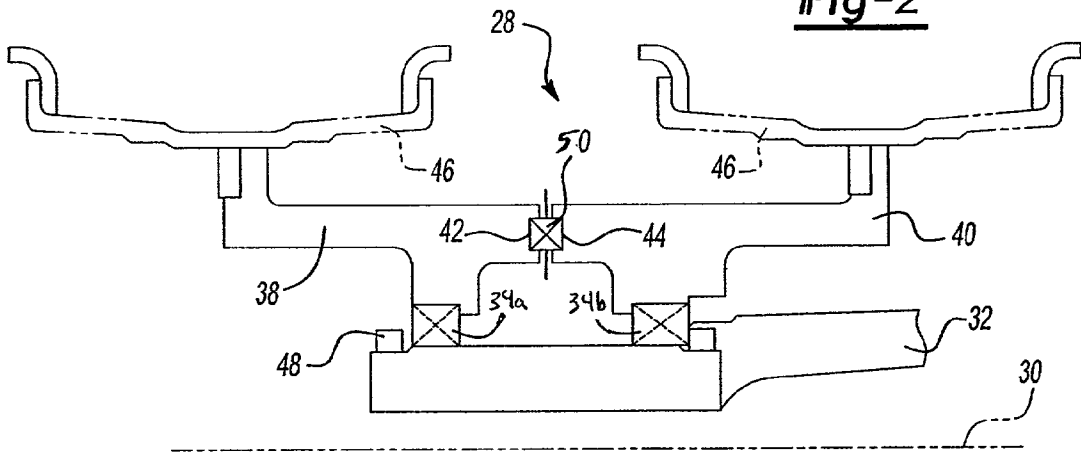
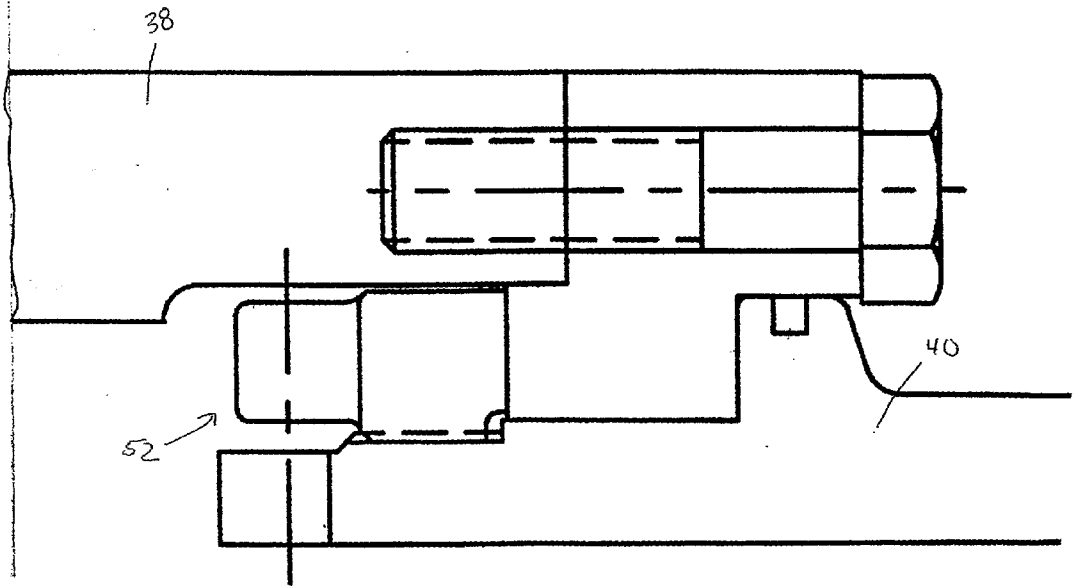
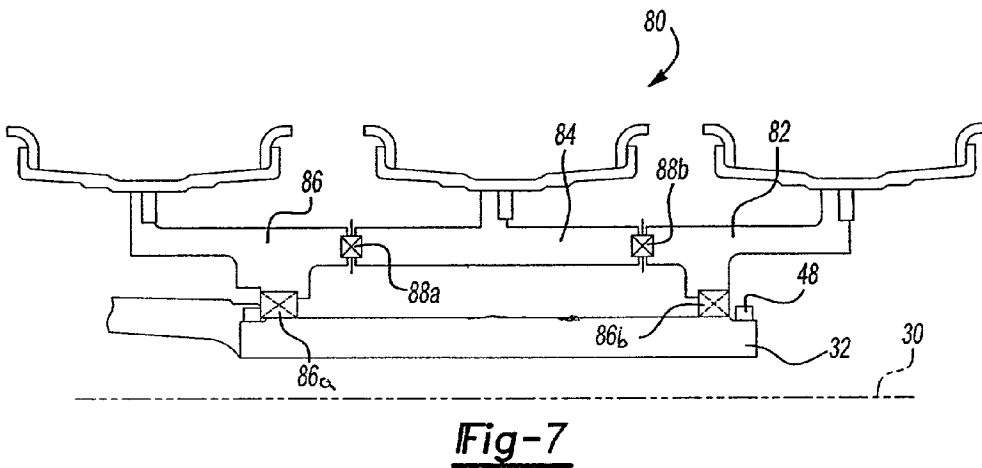
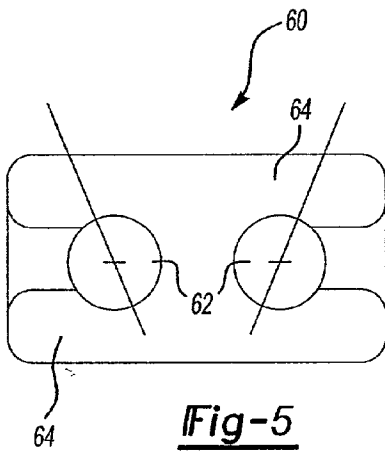
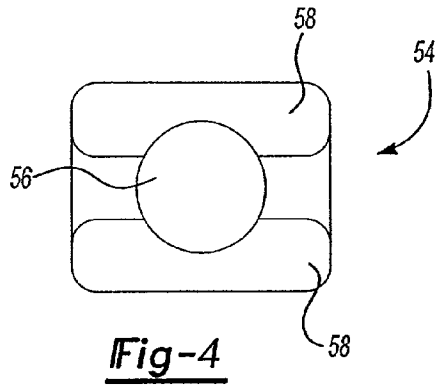

Fig. 3





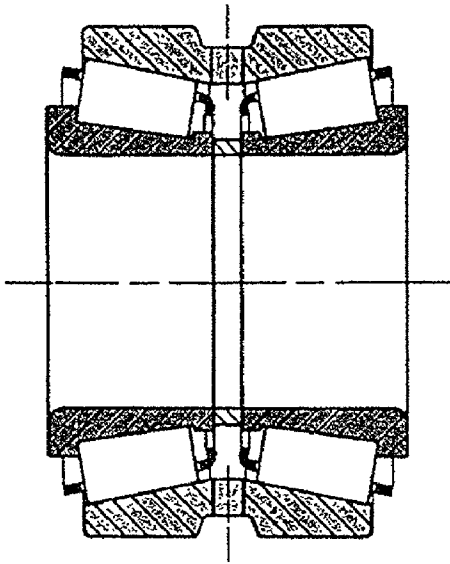

Fig. 6A

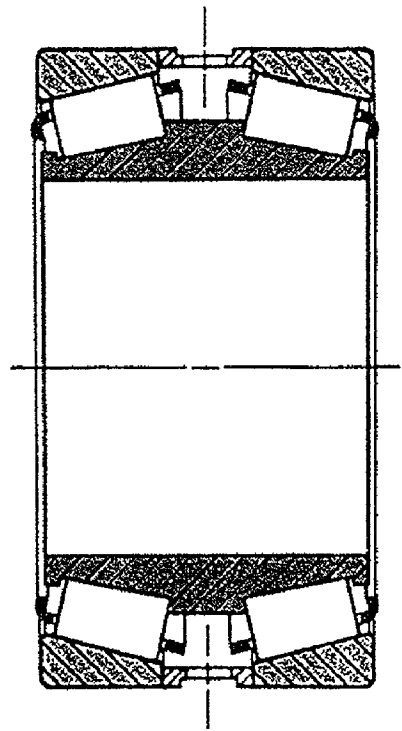

Fig. 6B

INDEPENDENTLY ROTATING WHEELS

BACKGROUND OF THE INVENTION

[0001] This invention relates to an axle assembly having multiple wheels at each end of the axle in which one wheel on one axle end is permitted to rotate relative to the other wheels on the same axle end. More specifically, the invention relates to bearing members that support adjacent wheel hubs to achieve independent relative rotation during turns.

[0002] Axle assemblies have typically incorporated dual wheels on either end of the axle to increase the load bearing capacity for heavy duty vehicles. Typically the pair of wheels on each end of the axle assembly is secured together so that they rotate at the same speed about an axis even during turns. Most off-highway vehicles, such as lift trucks, container handlers, front end loaders, etc., have duty cycles that include numerous turning maneuvers, which cause significant tire wear. The tire wear is a direct result of tire scrub, or drag, caused by wheels that are rigidly secured together for rotation at the same speed but which must travel different distances at the inside and outside of the turning radius. Tire wear and maintenance on heavy duty off-highway vehicles due to scrub cost thousands of dollars annually per vehicle.

[0003] Additionally, tire scrub reduces vehicle stability during turning maneuvers. As a vehicle moves through a turn, tire scrub detracts from the net ground coefficient necessary for traction, braking, and side forces in turns. Tire scrub also causes premature wear of various wheel end components, such as wheel rims. The wheel rims can fail prematurely due to added stresses caused by repeated tire scrub. Finally, tire scrub increases fuel consumption as well as powertrain wear and tear in drive axles.

[0004] For the above reasons, it would be desirable to reduce tire scrub by having a wheel end that allows adjacent wheel hubs to rotate independently relative to one other to allow each tire to rotate at different speeds through a turn.

SUMMARY OF THE INVENTION

[0005] A wheel end assembly having a dual wheel configuration includes independently rotating wheel hubs to reduce tire wear. In a disclosed embodiment of this invention, the wheel end assembly includes a spindle defining an axis of rotation a first wheel hub supported on the spindle by a first bearing member and a second wheel hub supported on the spindle by a second bearing member for rotation about the axis. A third bearing member is mounted between the first and second wheel hubs to support and permit the first and second wheel hubs to rotate independently from each other under predetermined conditions. In straight path operation the wheel hubs rotate together at the same speed, but during turns the third bearing member allows each wheel hub to turn at an ideal speed for that respective wheel hub.

[0006] Preferably a fastening assembly is mounted at one end of the spindle to retain the wheel hubs on the spindle. The fastening assembly also prohibits linear movement of the wheel hubs along the axis.

[0007] In one disclosed embodiment, the third bearing member is positioned between the first and second bearing members along the axis. Preferably, the third bearing mem-

ber is solely supported between the first and second wheel hubs to allow each wheel hub to rotate independently from the other.

[0008] The subject invention offers a simple and compact design for independently rotating wheel hubs that significantly reduces tire wear resulting in less vehicle down time and which decreases overall maintenance cost. Further, because tire scrub is eliminated vehicle stability is improved and fuel economy is improved. The subject invention, described above for a dual wheel configuration, can easily be extended to multiple-wheel configurations.

[0009] These and other features of the present invention can be best understood from the following specifications and drawings, the following of which is a brief description.

BRIEF DESCRIPTION OF THE DRAWINGS

[0010] FIG. 1A is a schematic view of a typical off-highway vehicle powertrain.

[0011] FIG. 1B is a schematic view of a typical on-highway vehicle powertrain.

[0012] FIG. 2 is a cross-sectional view of a top half of one embodiment of a wheel end assembly incorporating the subject invention.

[0013] FIG. 3 is a cross-sectional view of a bushing.

[0014] FIG. 4 is a schematic view of a ball bearing assembly.

[0015] FIG. 5 is a schematic view of a double-row angular contact ball bearing.

[0016] FIG. 6a is a schematic view of a taper roller bearing.

[0017] FIG. 6b is an alternate view of a taper roller bearing.

[0018] FIG. 7 is a cross-sectional view of a top half of an alternate embodiment of a wheel end assembly incorporating the subject invention and showing more than two wheels on the same axle end.

DETAILED DESCRIPTION OF A PREFERRED EMBODIMENT

[0019] FIG. 1A shows an overhead schematic view of a typical vehicle driveline 10 for a heavy-duty off-highway vehicle. FIG 1B shows a typical on-highway vehicle driveline 110. The drivelines 10, 110 include an engine 12 coupled to a transmission 14, which together provide driving input torque to a drive shaft 16 that extends to a drive axle 18. The drive axle 18 can be a single drive axle or a tandem drive axle. The vehicle also typically includes non-driving axles such as a front non-drive steer axle 20 and in the on-highway configuration, trailer axles 22.

[0020] Typically each axle 18, 20, 22 includes a wheel end assembly with dual wheels 24a, 24b on either end of the respective axle to increase the load bearing capacity for the heavy duty vehicle. As the vehicle maneuvers through a turn, the outer wheel 24b on the wheel end on the outside of the turn has a greater distance to travel than the inner wheel 24a. Conversely, on the inside of the turn, the inner wheel 24a travels farther than the outer wheel 24b. Typically, the dual wheels are rigidly connected to each other so that each

wheel **24a**, **24b** rotates at the same speed through the turn. This causes tire scrub, which results in premature tire wear and wheel end component wear.

[0021] The subject invention allows each of the wheels **24a**, **24b** to rotate independently from each other so that tire scrub is eliminated during turning operations. It should be understood that this invention can be used in any type of axle that incorporates dual wheels and that while the invention is especially useful in off-highway vehicle applications as shown in **FIG. 1A**, the invention can also be used in an on-highway configuration, shown in **FIG. 1B**. A preferred application is a heavy-duty lift truck that utilizes a single front drive axle **18** as shown in **FIG. 1A** with dual wheels **24a**, **24b** on each end.

[0022] A wheel end assembly **28** is shown in **FIG. 2**. The wheel end assembly **28** includes a spindle **32** or other support shaft member that defines a wheel axis of rotation **30**. As discussed above, the wheel end assembly **28** can be used on either a driving or non-driving axle. The wheel end assembly **28** further includes a first wheel hub **38** and a second wheel hub **40** that are supported adjacent to each other on the spindle **32** via bearings **34a**, **34b**. Typically, taper roller bearings are used for heavy-duty applications. Further, it should be understood that bearings **34a**, **34b** can be the same but do not have to be equal with each other.

[0023] A third bearing member **50** is mounted between the hubs **38**, **40** to permit the hubs **38**, **40** to rotate relative to one another about the axis **30**. Preferably, the third bearing member **50** is solely supported between the hubs **38**, **40**, i.e., the bearing member **50** is not supported on the spindle **32**. The third bearing member **50** is mounted on opposing faces **42**, **44** of the hubs **38**, **40** and is not supported by the spindle **32**. Wheel rims **46** are mounted to each hub **38**, **40** and the tires **24a**, **24b** are mounted to the respective rims **46**. A fastening assembly is used to hold the assembly together on the spindle **32**. Preferably, a nut **48** mounted on the outer end of the spindle **32** retains the hubs **38**, **40** in the proper axial location and prevents any linear movement along the axis **30**. While a nut **48** is preferred, other known fasteners could also be used.

[0024] Typically, each hub **38**, **40** is supported on the spindle **32** with a pair of bearings, however, because the third bearing member **50** is incorporated between the hubs **38**, **40** only a single bearing **34a**, **34b** is needed to support each hub **38**, **40** on the spindle **32**. This reduces the number of bearings required and eases the bearing preload process for the wheel, which in turn reduces cost and assembly time.

[0025] Preferably, the third bearing member **50** is positioned between the bearings **34** and has a diameter that extends greater radial distance away from the axis **30** than the diameters of the bearings **34a**, **34b** supported by the spindle **32**.

[0026] Any suitable type of bearing member known in the art can be used for the third bearing member **50**, however, the preferred bearing configuration is a bushing **52**, shown in **FIG. 3**, that supports bi-directional axial and radial loads. The bushing can be made from a single type of material or can include a coating. For example, the bushing can be a typical bronze bushing such as that found in traditional planet pinion shafts or a nylon-coated steel bushing.

[0027] Other alternate bearing configurations include a radial four-point-contact ball bearing, a radial crossed roller

bearing, a double-row angular-contact ball bearing, or a double-row taper roller bearing. A typical ball bearing **54** is shown in **FIG. 4** and includes a plurality of spherical balls **56** supported on races **58** in a single row. A double-row angular-contact ball bearing **60** is shown in **FIG. 5** and includes two (2) rows of spherical ball members **62** supported on a pair of races **64**. Alternate embodiments of a double-row tapered roller bearing **66** are shown in **FIGS. 6a** and **6b**, each of which includes two (2) rows of cylindrical bearing members **68** supported on races **70**.

[0028] The third bearing member **50** can be of lower capacity than typical wheel bearing members because the number of revolutions is significantly reduced as it rotates only during turns.

[0029] An alternate embodiment of a wheel end assembly **80** is shown in **FIG. 7**, illustrating that the concept can be extended to more than two wheels. This wheel end assembly **80** includes an outer hub **82**, a middle hub **84**, and an inner hub **86**. The inner **86** and outer **82** hubs are supported on the spindle **32** via bearings **86a**, **86b** for rotation about the axis **30**. It should be understood that bearings **86a**, **86b** can be the same but do not have to be equal with each other. The fastening assembly retains the hubs **82**, **84**, **86** on the spindle **32**. Wheel rims **46** are mounted to each of the hubs **82**, **84**, **86** as is known in the art. Bearing members **88a**, **88b** are positioned between the hubs **82**, **84**, **86** to allow independent rotation of the hubs **82**, **84**, **86** relative to each other. A first bearing member **88a** is positioned between the inner **86** and middle **84** hubs and a second bearing member **88b** is positioned between the outer **82** and middle hubs **84**. The bearing members **88a**, **88b** are similar to those discussed above with regard to **FIG. 2**.

[0030] The subject invention provides a multiple wheel end assembly with independently rotating wheel hubs that greatly reduces tire wear, increase fuel economy, improves vehicle stability, and reduces premature wheel end component wear.

[0031] Although a preferred embodiment of this invention has been disclosed, a worker of ordinary skill in this art would recognize that certain modifications would come within the scope of this invention. For that reason, the following claims should be studied to determine the true scope and content of this invention.

1. A wheel end assembly comprising:
 - a spindle defining an axis of rotation;
 - a first wheel hub supported on said spindle by at least one first bearing member for rotation about said axis;
 - a second wheel hub supported on said spindle adjacent to said first wheel hub by at least one second bearing member for rotation about said axis; and
 - at least one third bearing member mounted between said first and second wheel hubs to permit said first and second wheel hubs to rotate independently from each other.
2. An assembly as set forth in claim 1 including a fastener mounted on one end of said spindle to prevent linear movement of said first and second wheel hubs along said axis.

3. An assembly as set forth in claim 1 wherein said at least one first bearing member is a single bearing and said at least one second bearing member is a single bearing.

4. An assembly as set forth in claim 1 including a third wheel hub positioned on an opposite side of said second wheel hub from said first wheel hub for rotation about said axis and including at least one fourth bearing member for allowing said third and second wheel hubs to rotate independently from each other wherein said third bearing member is mounted between said first and second wheel hubs and said fourth bearing member is mounted between said second and third wheel hubs.

5. An assembly as set forth in claim 4 wherein said at least one third bearing member is solely supported between said first and second wheel hubs to permit said first and second wheel hubs to rotate independently from each other under and wherein said at least one fourth bearing member is solely supported between said second and third wheel hubs.

6. An assembly as set forth in claim 1 wherein said at least one third bearing member is a bushing that can support bi-directional axial and radial loads.

7. An assembly as set forth in claim 6 wherein said bushing is a bronze bushing.

8. An assembly as set forth in claim 6 wherein said bushing is a nylon-coated steel bushing.

9. An assembly as set forth in claim 1 wherein said at least one third bearing member is solely supported between said first and second wheel hubs to permit said first and second wheel hubs to rotate independently from each other under predetermined conditions.

10. An assembly as set forth in claim 1 wherein said at least one third bearing member is a radial four-point-contact ball bearing.

11. An assembly as set forth in claim 1 wherein said at least one third bearing member is a double-row angular-contact ball bearing.

12. An assembly as set forth in claim 1 wherein said at least one third bearing is a double-row taper roller bearing.

13. A wheel end assembly comprising:

a spindle defining an axis of rotation;

a first wheel hub supported on said spindle by a first bearing member for rotation about said axis;

a second wheel hub supported on said spindle for rotation about said axis by a second bearing member spaced apart from said first bearing member;

a third bearing member solely supported between said first and second wheel hubs to permit said first and second wheel hubs to rotate independently from each other under predetermined conditions; and

at least one fastening element for retaining said first and second wheel hubs on said spindle to prevent linear movement of said hubs along said axis.

14. An assembly as set forth in claim 13 wherein said third bearing member is positioned between said first and second bearing members.

15. An assembly as set forth in claim 13 wherein said third bearing member is located at a greater radial distance away from said axis than said first or second bearing members.

16. An assembly as set forth in claim 13 wherein said second wheel hub is comprised of an inner hub member and an outer hub member wherein said outer hub member is supported on said spindle via said second bearing member and said third bearing member is solely supported between said first wheel hub and said inner hub member and including a fourth bearing member solely supported between said inner hub member and said outer hub member such that said first wheel hub and said inner hub member can rotate independently from one another and said inner and outer hub members can rotate independently from one another.

17. An assembly as set forth in claim 16 wherein said inner bearing member is solely supported by said third and fourth bearing members for rotation about said axis.

* * * * *