



(19) **United States**

(12) **Patent Application Publication**
Steigerwald et al.

(10) **Pub. No.: US 2003/0230754 A1**

(43) **Pub. Date: Dec. 18, 2003**

(54) **CONTACTING SCHEME FOR LARGE AND SMALL AREA SEMICONDUCTOR LIGHT EMITTING FLIP CHIP DEVICES**

(52) **U.S. Cl. 257/91**

(76) **Inventors: Daniel A. Steigerwald**, Cupertino, CA (US); **Jerome C. Bhat**, San Francisco, CA (US); **Michael J. Ludowise**, San Jose, CA (US)

(57) **ABSTRACT**

Correspondence Address:
Rachel V. Leiterman
Patent Law Group LLP
Suite 223
2635 North First Street
San Jose, CA 95134-2049 (US)

In accordance with the invention, a light emitting device includes a substrate, a layer of first conductivity type overlying the substrate, a light emitting layer overlying the layer of first conductivity type, and a layer of second conductivity type overlying the light emitting layer. A plurality of vias are formed in the layer of second conductivity type, down to the layer of first conductivity type. The vias may be formed by, for example, etching, ion implantation, or selective growth of the layer of second conductivity type. A set of first contacts electrically contacts the layer of first conductivity type through the vias. A second contact electrically contacts the layer of second conductivity type. In some embodiments, the area of the second contact is at least 75% of the area of the device. In some embodiments, the vias are between 2 and 100 microns wide and spaced between 5 and 1000 microns apart.

(21) **Appl. No.: 10/172,311**

(22) **Filed: Jun. 13, 2002**

Publication Classification

(51) **Int. Cl.⁷ H01L 33/00**

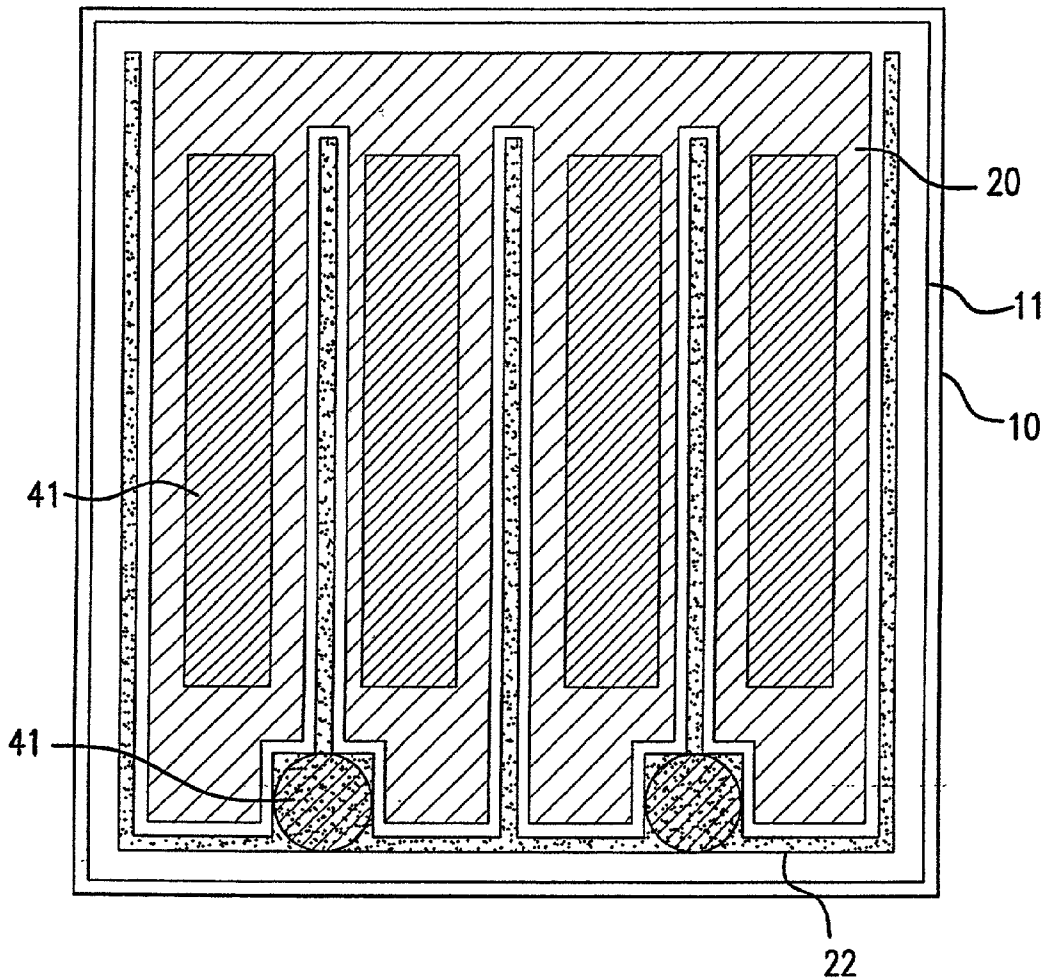

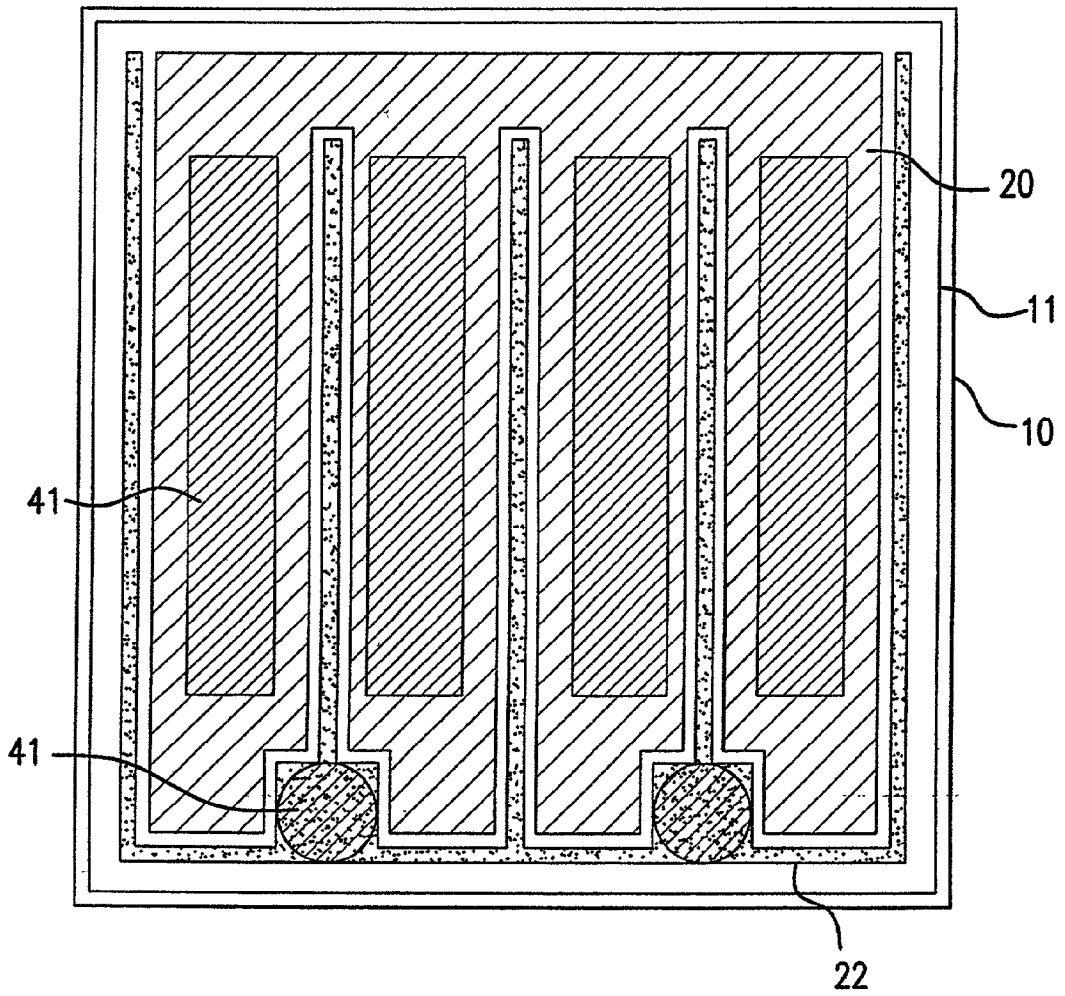

FIG. 1

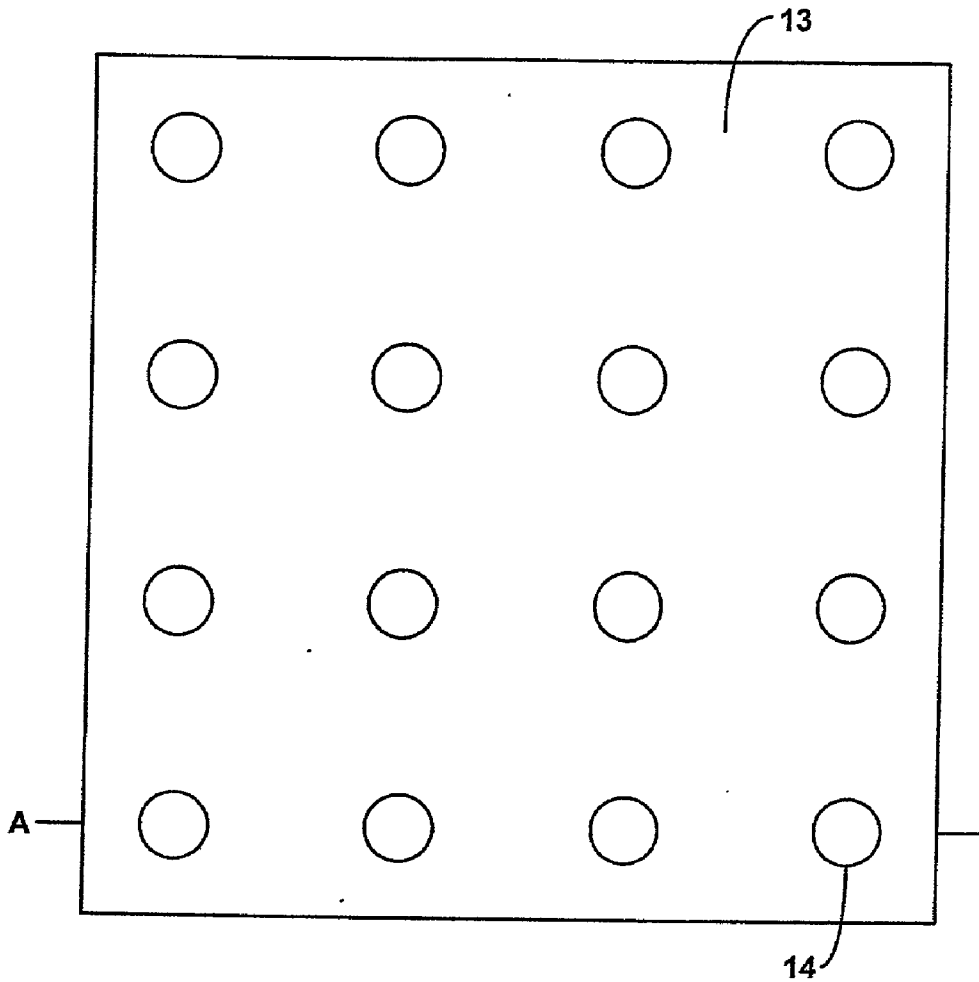

Fig. 2

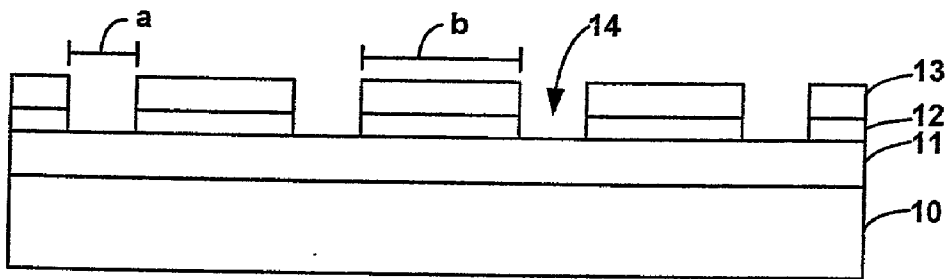

Fig. 3

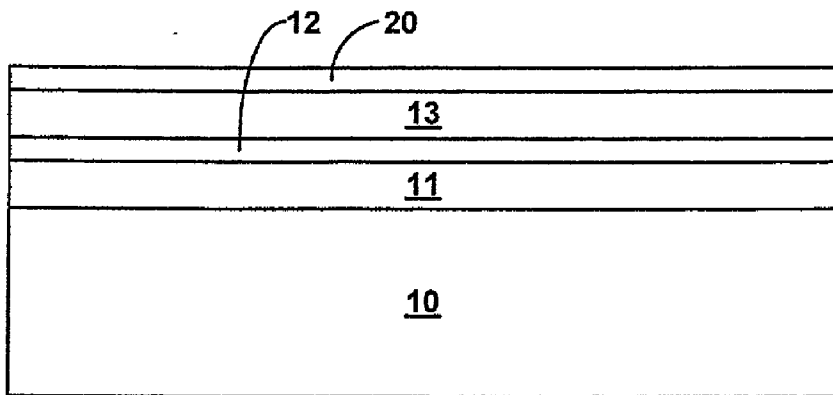

Fig. 4A

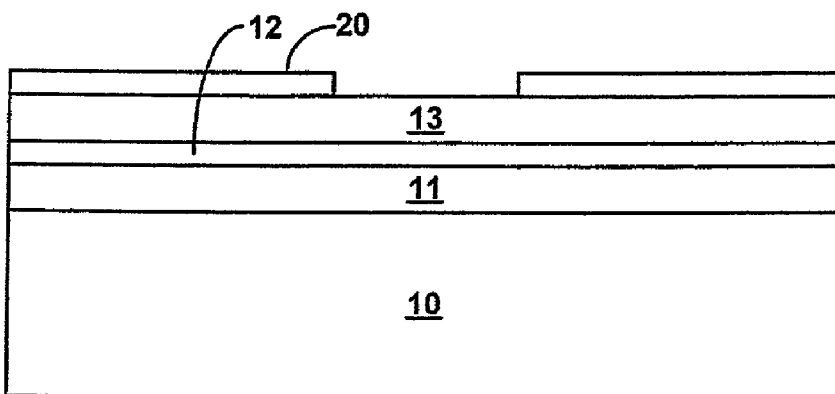

Fig. 4B

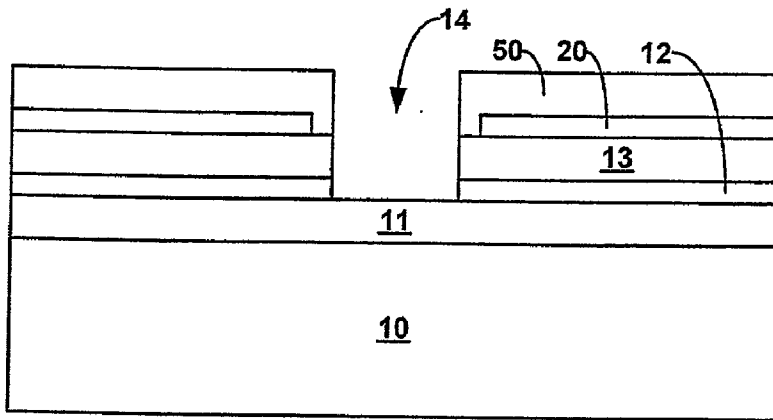

Fig. 4C

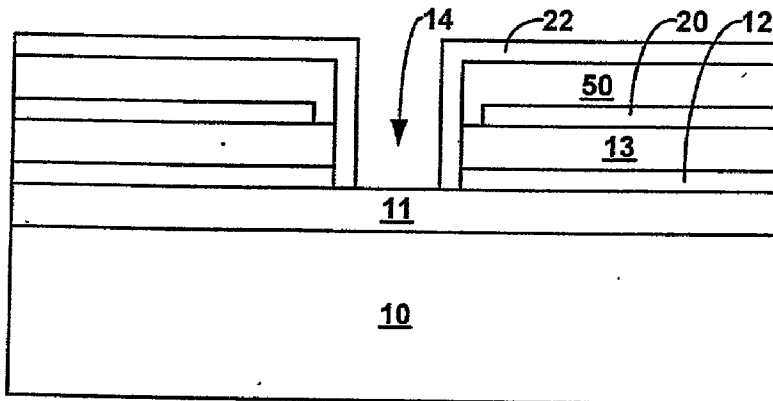

Fig. 4D

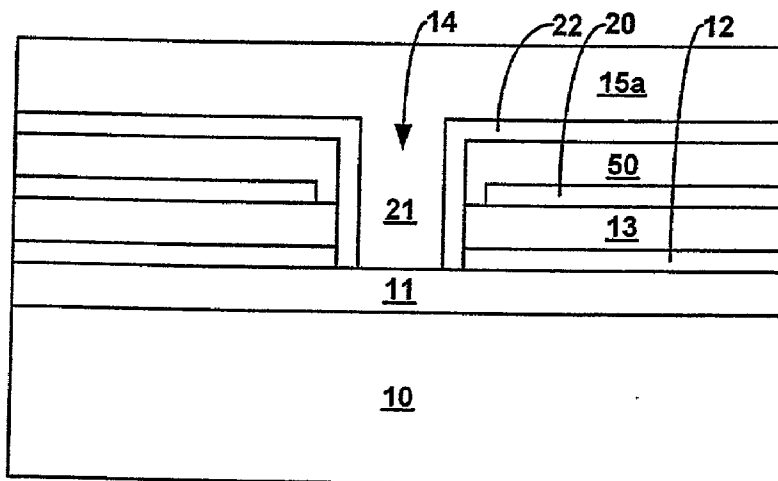

Fig. 4E

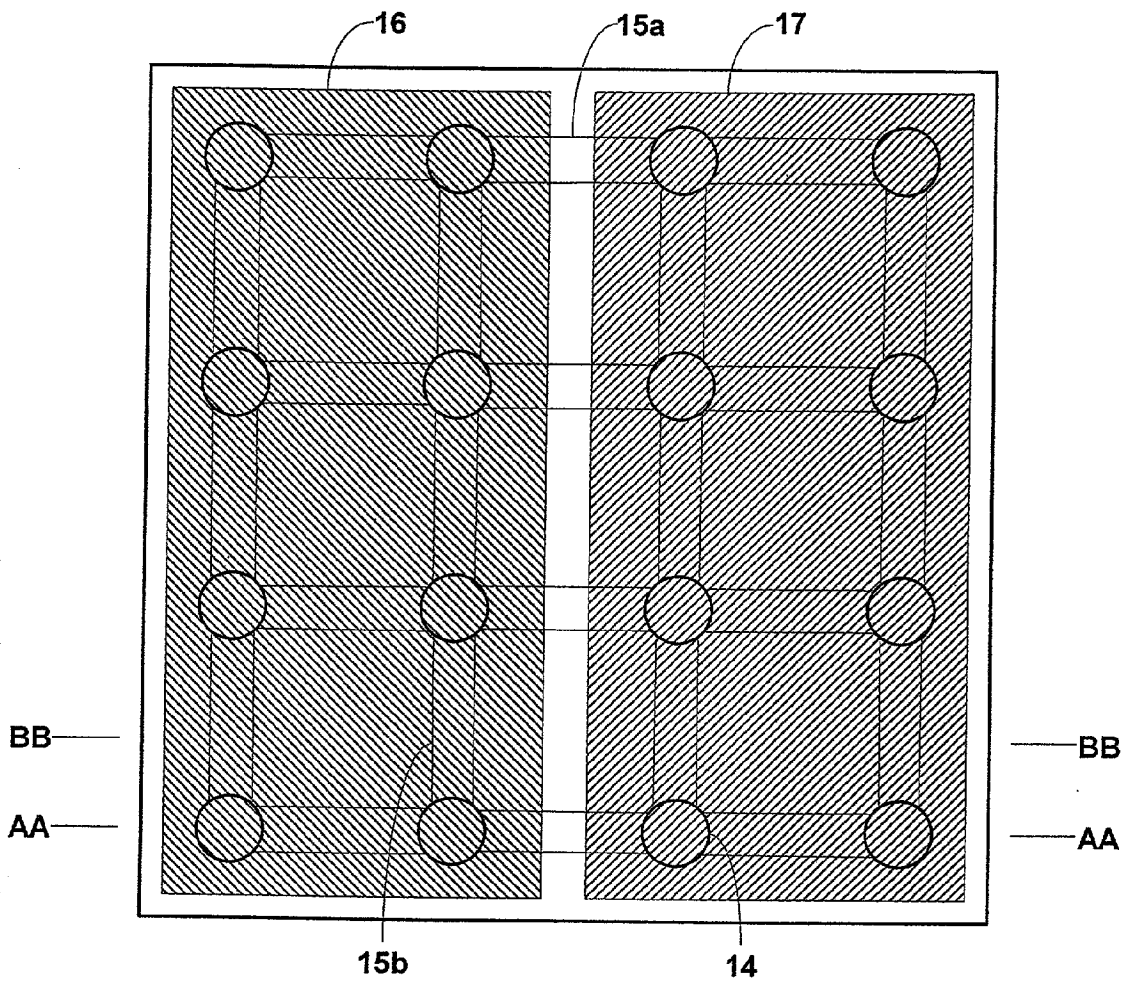

Fig. 5

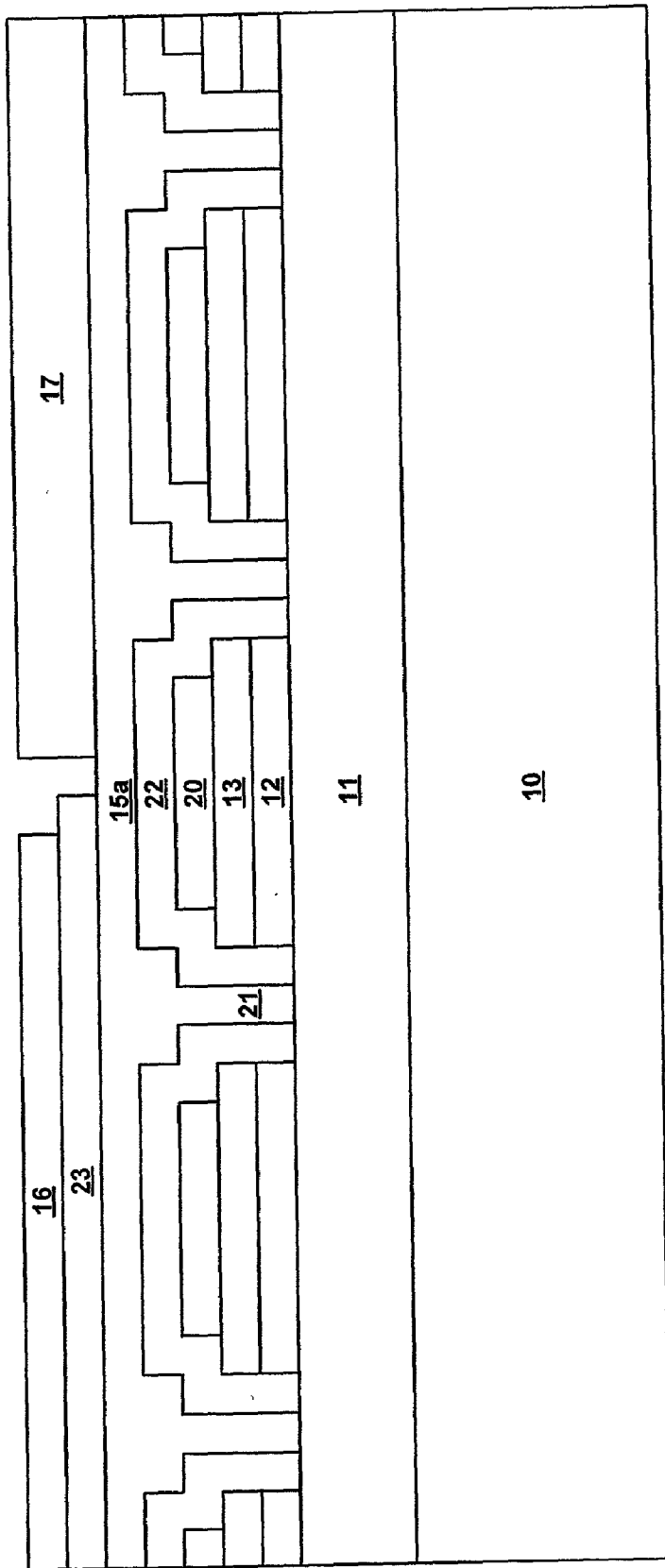

Fig. 6

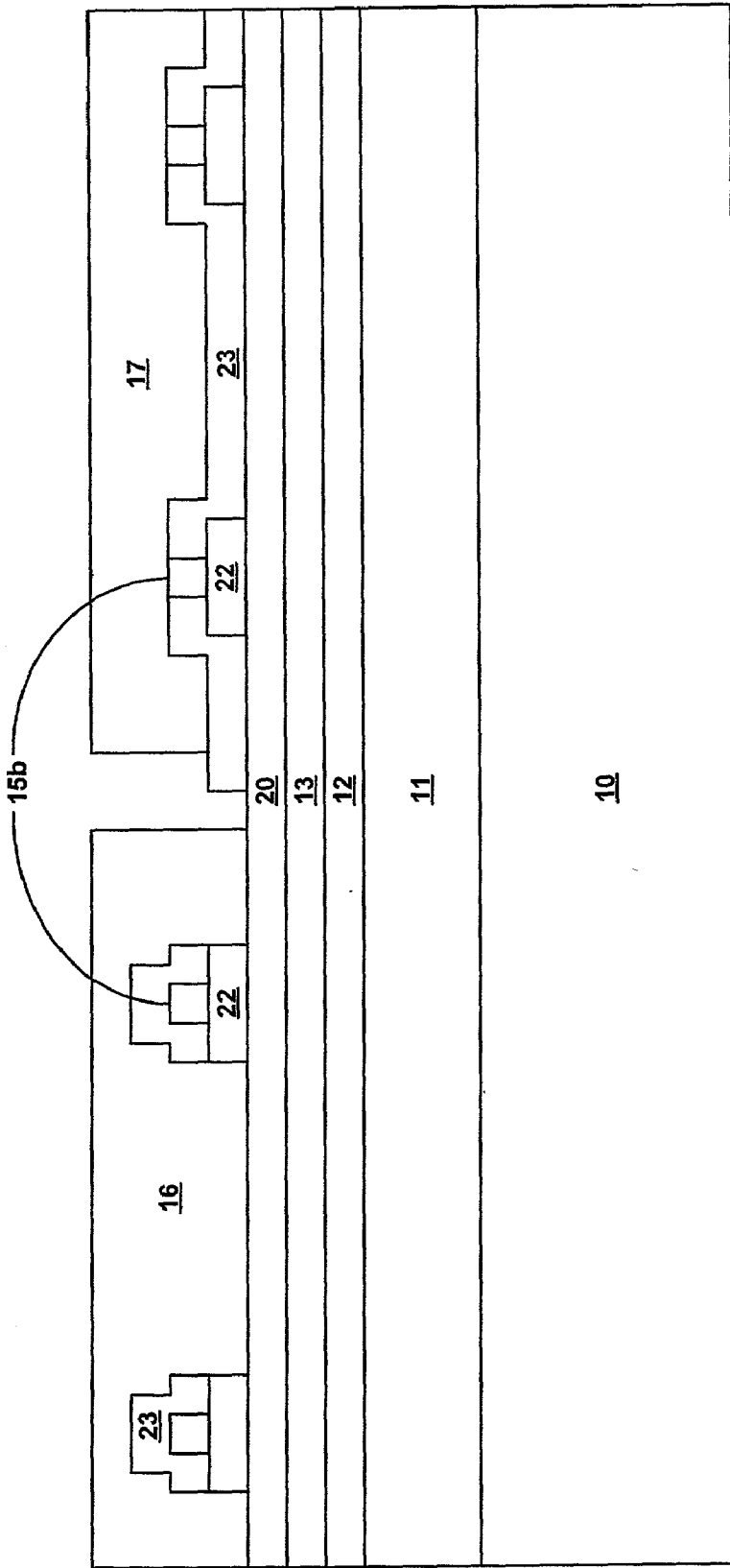

Fig. 7

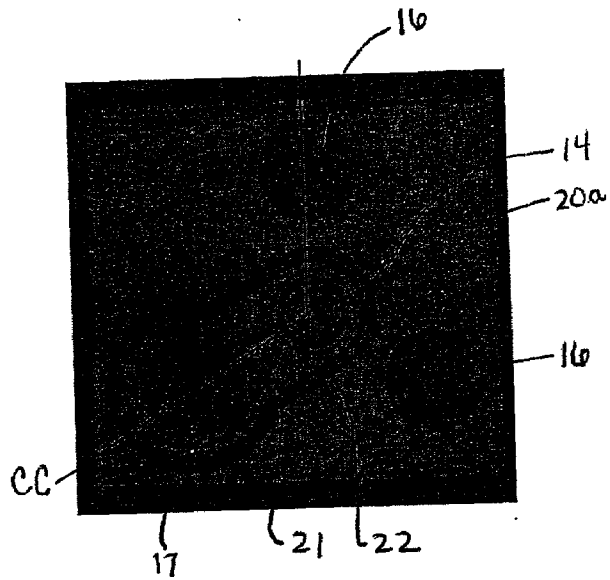

FIG. 8

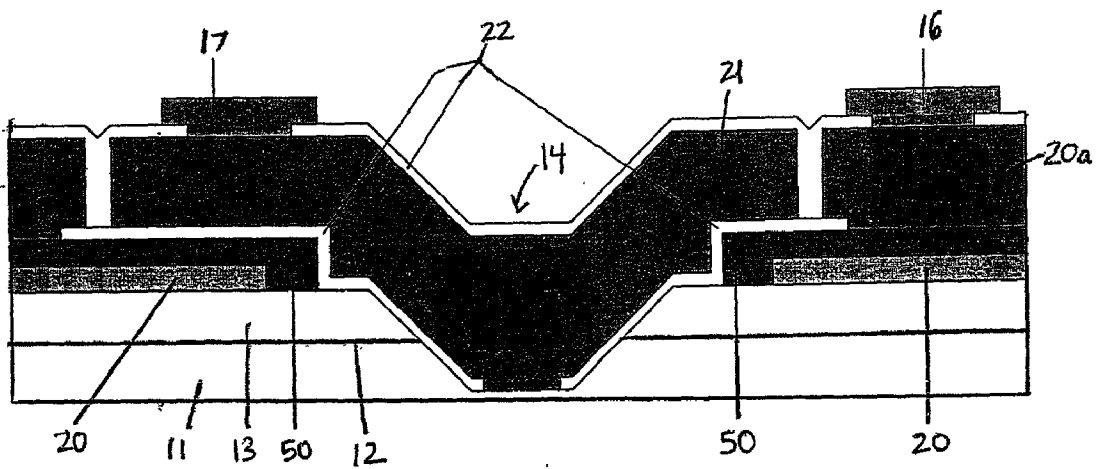

FIG. 9

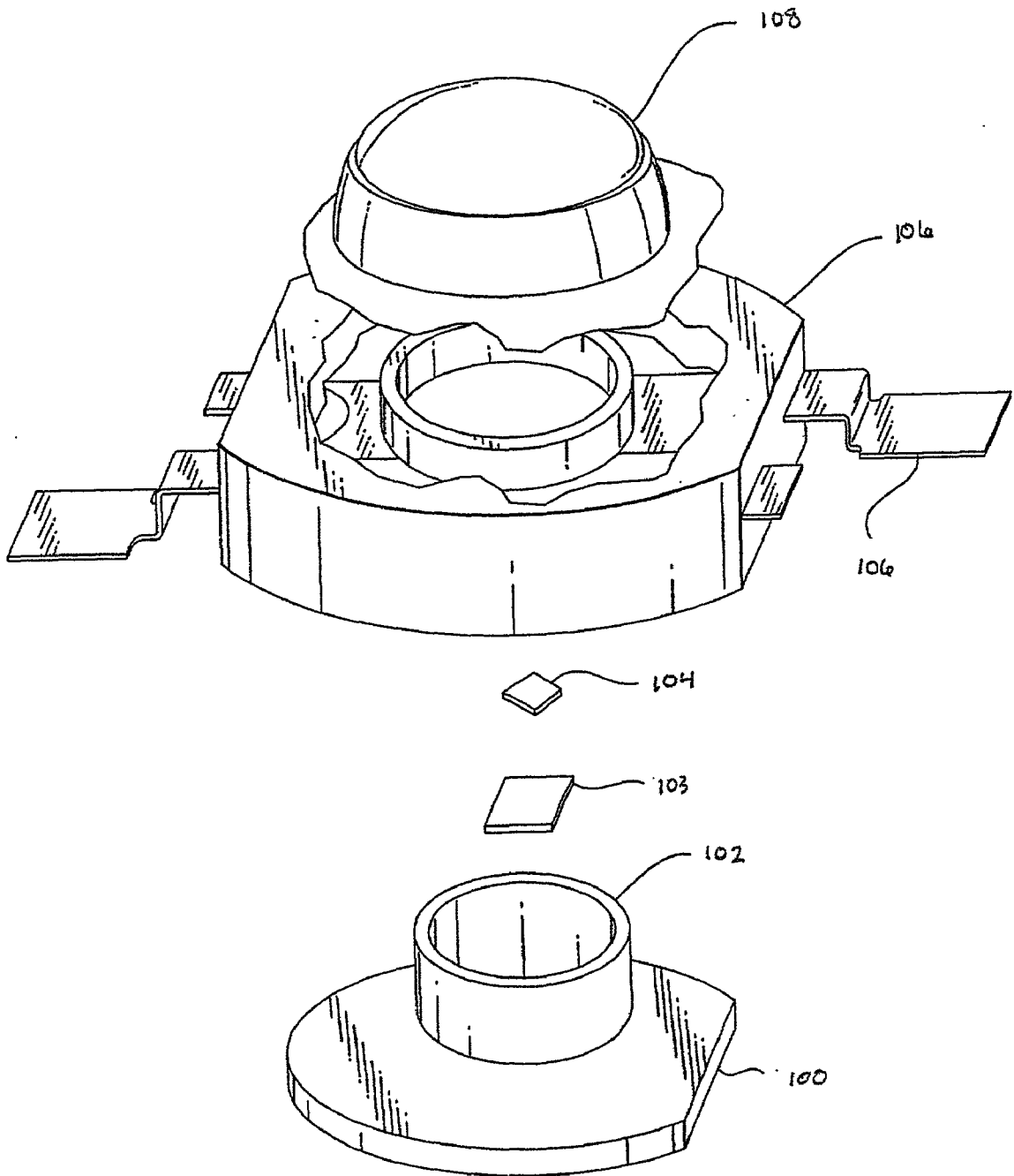

Figure 10

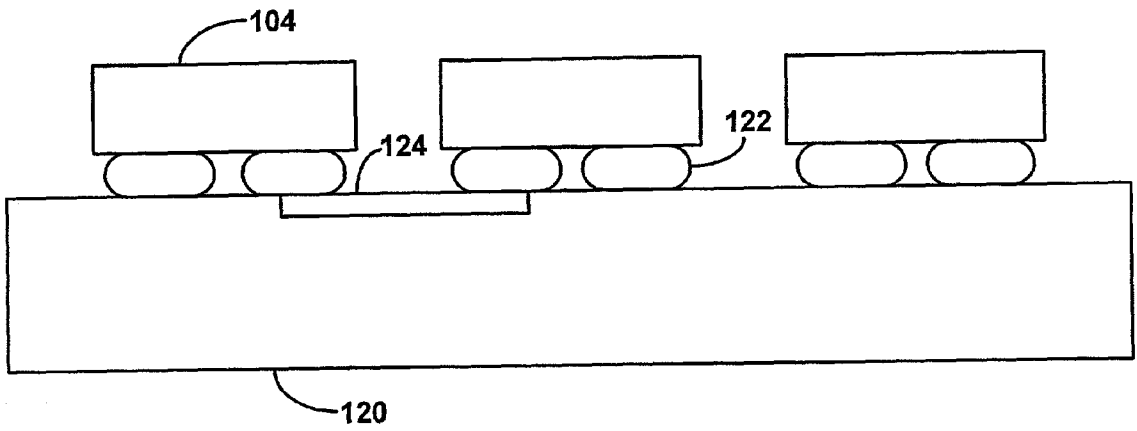

Fig. 11

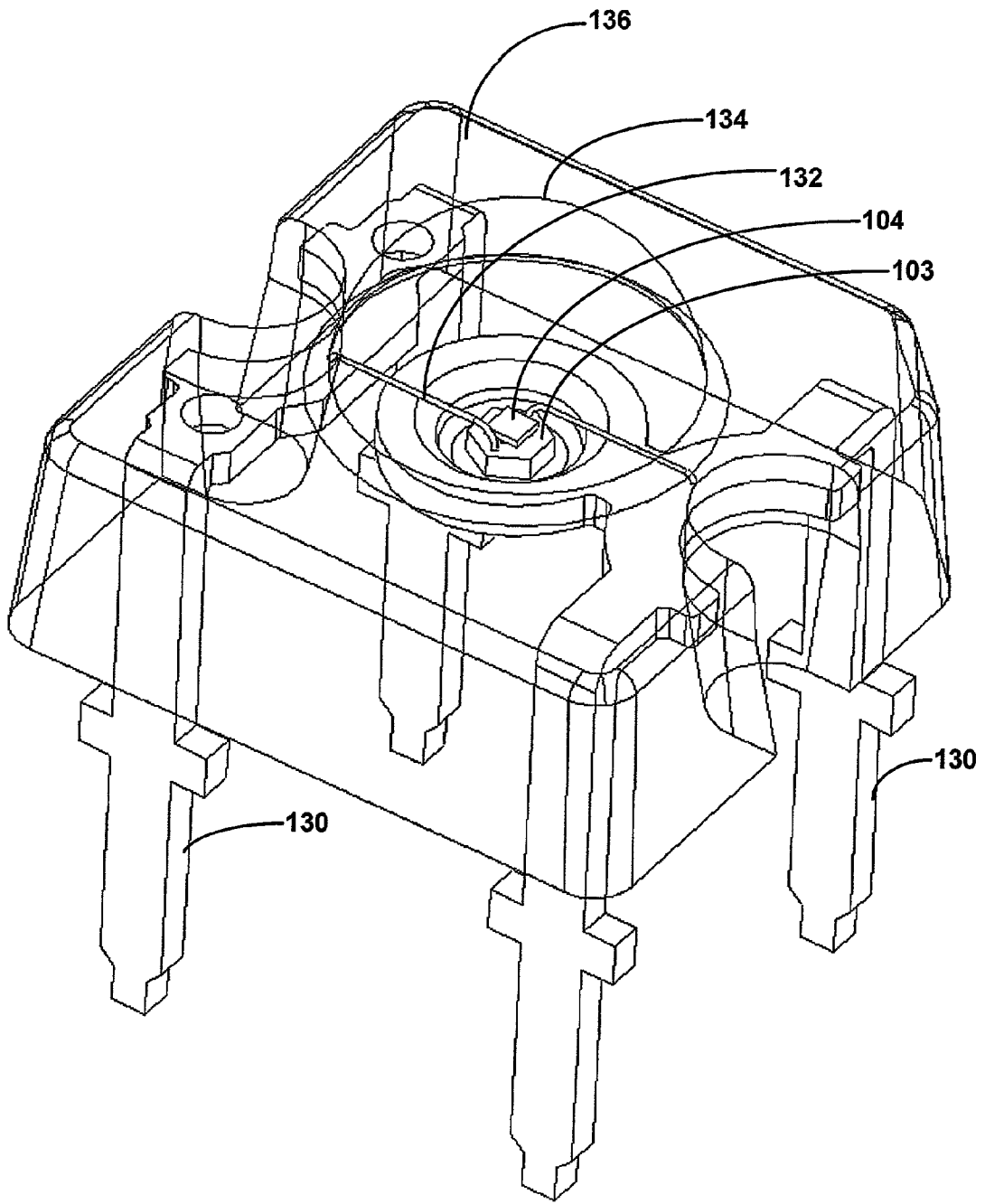

Fig. 12

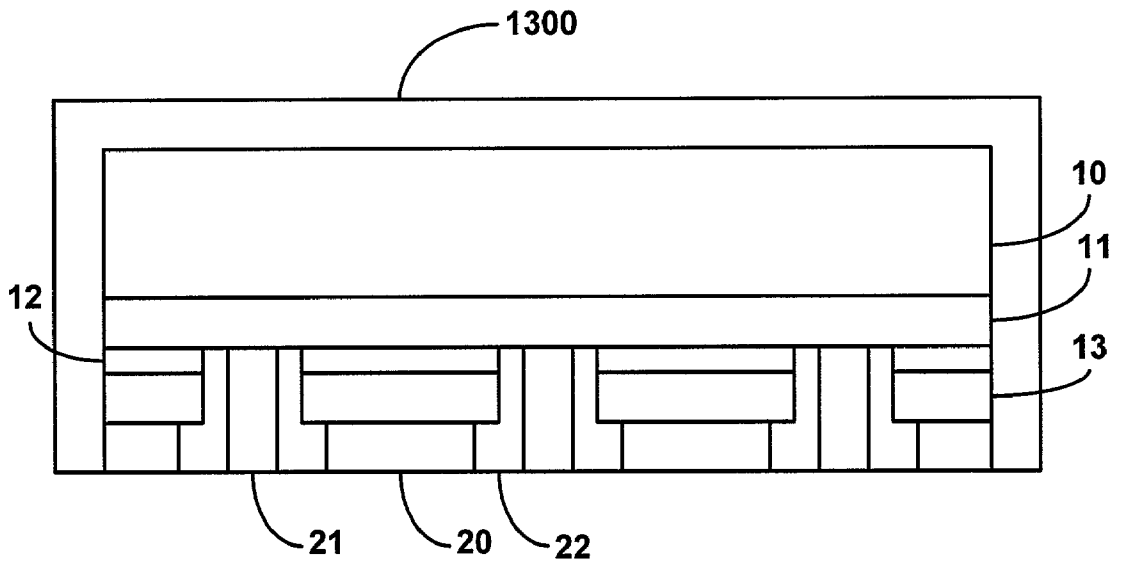

Fig. 13

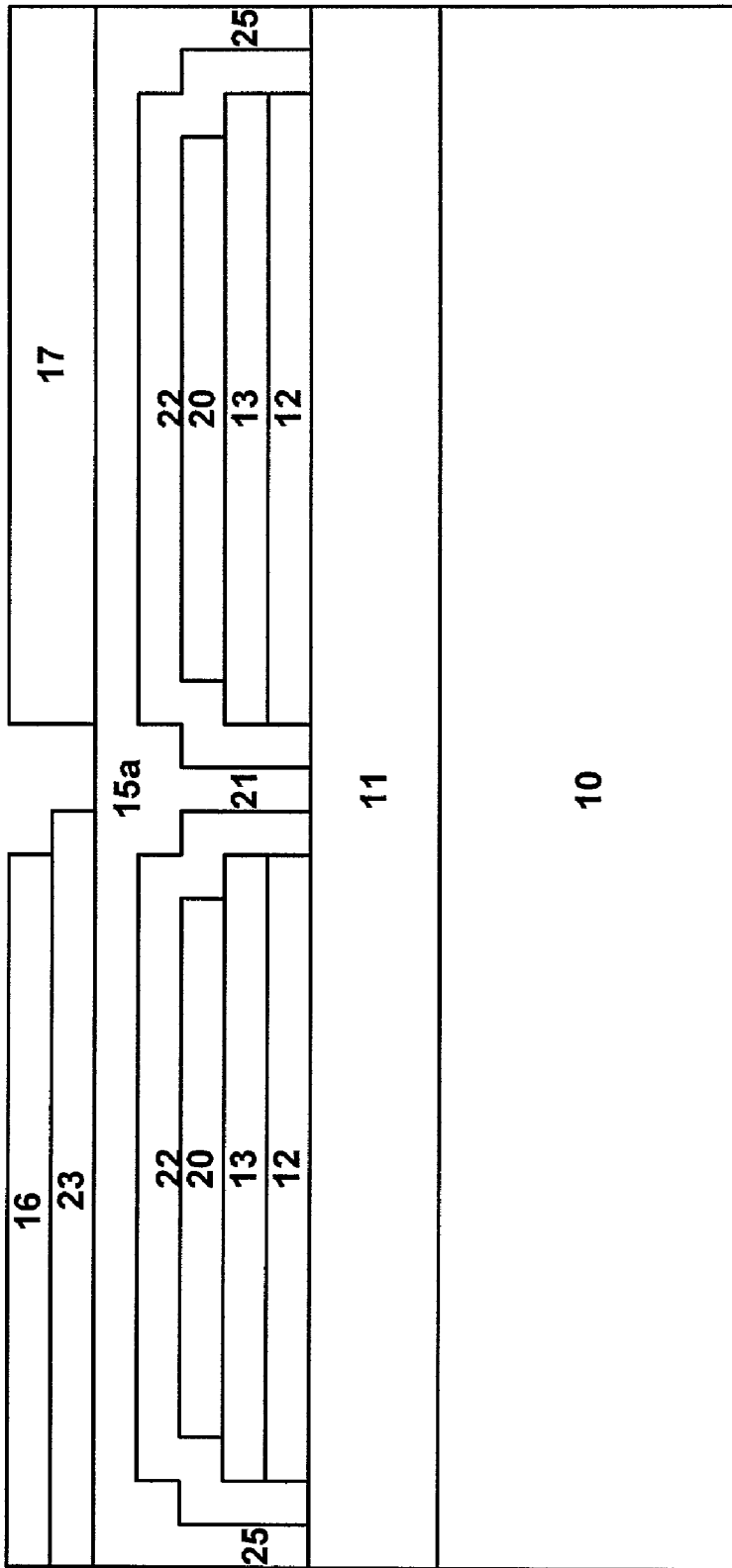

Fig. 14

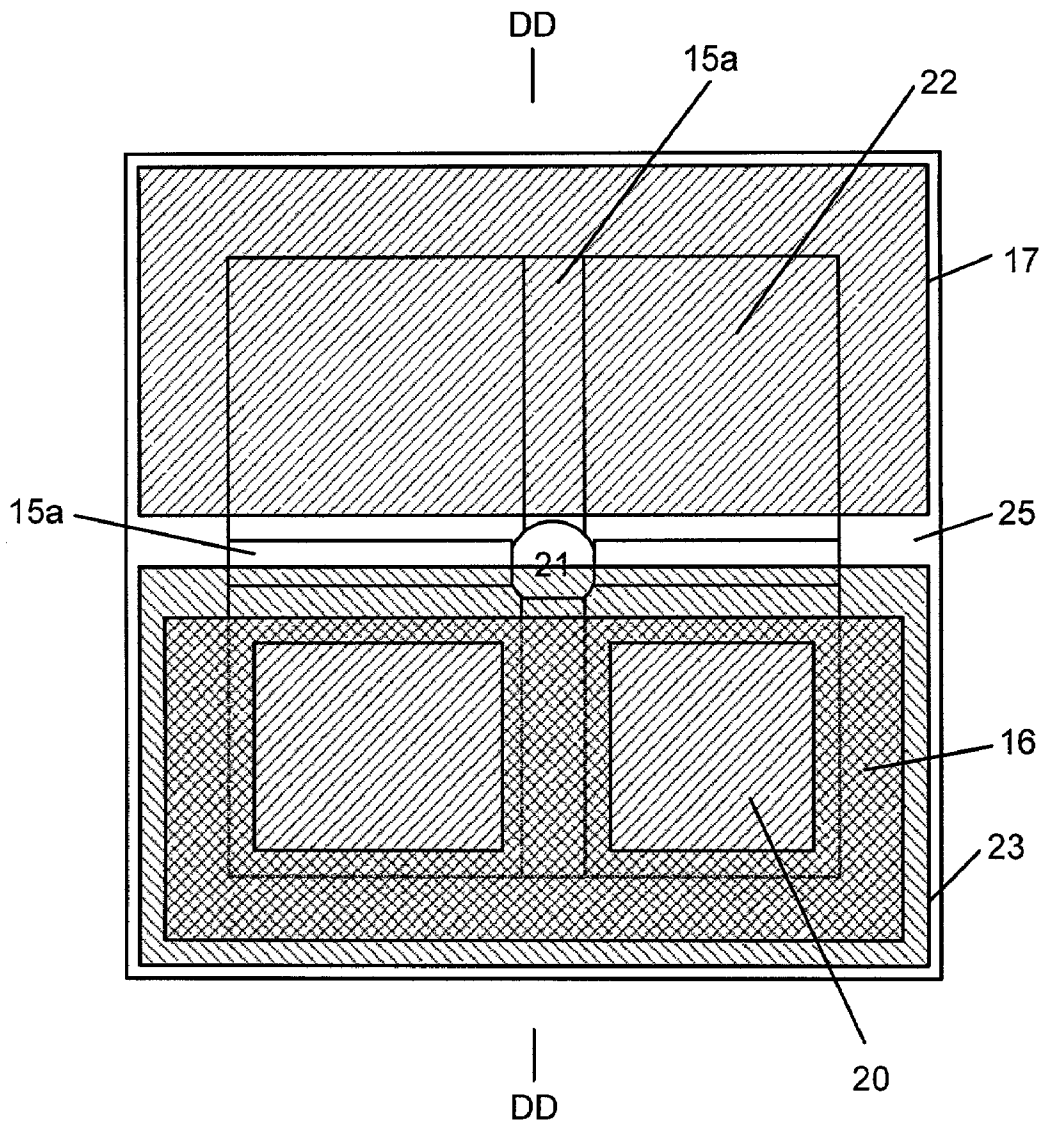

Fig. 15

CONTACTING SCHEME FOR LARGE AND SMALL AREA SEMICONDUCTOR LIGHT EMITTING FLIP CHIP DEVICES

FIELD OF THE INVENTION

[0001] This invention relates generally to light emitting diodes and more specifically to contacts for light emitting diodes.

BACKGROUND

[0002] Semiconductor light emitting devices such as light emitting diodes (LEDs) are among the most efficient light sources currently available. Material systems currently of interest in the manufacture of high brightness LEDs capable of operation across the visible spectrum include group III-V semiconductors, particularly binary, ternary, and quaternary alloys of gallium, aluminum, indium, and nitrogen, also referred to as III-nitride materials; and binary, ternary, and quaternary alloys of gallium, aluminum, indium, and phosphorus, also referred to as III-phosphide materials. Often III-nitride devices are epitaxially grown on sapphire, silicon carbide, or III-nitride substrates and III-phosphide devices are epitaxially grown on gallium arsenide by metal organic chemical vapor deposition (MOCVD) molecular beam epitaxy (MBE) or other epitaxial techniques. Often, an n-type layer (or layers) is deposited on the substrate, then an active region is deposited on the n-type layers, then a p-type layer (or layers) is deposited on the active region. The order of the layers may be reversed such that the p-type layers are adjacent to the substrate.

[0003] Some of these substrates are insulating or poorly conducting. In some instances, a window is attached to the semiconductor layers to enhance optical extraction. Devices fabricated from semiconductor crystals grown on or affixed to poorly conducting substrates must have both the positive and the negative polarity electrical contacts to the epitaxially grown semiconductor on the same side of the device. In contrast, semiconductor devices grown on conducting substrates can be fabricated such that one electrical contact is formed on the epitaxially grown material and the other electrical contact is formed on the substrate. However, devices fabricated on conducting substrates may also be designed to have both contacts on the same side of the device on which the epitaxial material is grown so as to improve light extraction from the LED chip. There are two types of devices with both the p- and n-contacts formed on the same side. In the first (also known as the flip chip), the light is extracted through the substrate or window material. In the second (also known as an epi-up structure), the light is extracted through the contacts, through the uppermost semiconductor layers of the device, or through the edges of the devices.

SUMMARY

[0004] In accordance with one embodiment of the invention, a light emitting device includes a substrate, a layer of first conductivity type, a light emitting layer, and a layer of second conductivity type. A plurality of vias are formed in the layer of second conductivity type, down to the layer of first conductivity type. The vias may be formed by, for example, etching, ion implantation, diffusion, or selective growth of at least one layer of second conductivity type. A

set of first contacts electrically contacts the layer of first conductivity type through the vias. A second contact electrically contacts the layer of second conductivity type. In some embodiments, the area of the second contact is at least 75% of the area of the device. In some embodiments, the vias are between about 2 and about 100 microns wide and spaced between about 5 and about 1000 microns apart. In some embodiments, the vias are formed in a square array, a hexagonal array, a rhombohedral array, or an arbitrary arrangement.

[0005] A light emitting device according to the present invention may offer several advantages. First, since the distance over which current must laterally spread within the semiconductor is reduced, the series resistance of the device may be reduced. Second, more light may be generated and extracted from the device since the area of the active region and the area of the second contact are larger than a device with a single first contact. Third, the invention may simplify the geometry of the interconnections between the device and the submount, enabling the use of, for example, low cost solder deposition methods.

[0006] In one embodiment, the first contacts are connected by a set of interconnects. An insulating layer is formed over the device. On one portion of the insulating layer, openings aligned with the second contacts are made in the insulating layer. On another portion of the insulating layer, openings aligned with the first contacts and the interconnects are made in the insulating layer. A first layer of a submount connection material such as solder is deposited on one portion of the device and a second layer of submount connection material is deposited on the other portion of the device. The two submount connection layers can then be used to connect the device to a submount.

BRIEF DESCRIPTION OF THE DRAWINGS

[0007] FIG. 1 is an example of a large junction light emitting device.

[0008] FIG. 2 is a plan view of a large junction light emitting device with vias.

[0009] FIG. 3 is a cross sectional view of the device shown in FIG. 2 along axis A.

[0010] FIGS. 4A-4E illustrate an embodiment of the present invention at various stages during fabrication.

[0011] FIG. 5 is a plan view of a light emitting device with vias and solder connections.

[0012] FIG. 6 is a cross sectional view of the device shown in FIG. 5 along axis AA.

[0013] FIG. 7 is a cross sectional view of the device shown in FIG. 5 along axis BB.

[0014] FIG. 8 is a plan view of a small junction light emitting device with vias.

[0015] FIG. 9 is a cross sectional view of the device shown in FIG. 8 along axis CC.

[0016] FIG. 10 is an exploded view of a light emitting device incorporated into a package.

[0017] FIG. 11 is a cross sectional view of multiple light emitting devices mounted on a board.

[0018] FIG. 12 illustrates a light emitting device incorporated into a package.

[0019] FIG. 13 illustrates a light emitting device with a wavelength converting material.

[0020] FIG. 14 is a cross sectional view of an alternative embodiment of a small junction light emitting device.

[0021] FIG. 15 is a plan view of an alternative embodiment of a small junction light emitting device.

DETAILED DESCRIPTION

[0022] In accordance with embodiments of the invention, a light emitting device such as a light emitting diode is formed with an n-contact comprising a plurality of vias. Such light emitting devices may be any suitable material system, including, for example, II-VI materials systems and III-V materials systems such as III-nitride, III-phosphide, and III-arsenide.

[0023] FIG. 1 illustrates an example of a large area III-nitride flip chip light emitting device. A large area device is a device with an area greater than or equal to about 0.2 square millimeter, while a small area device is a device with an area less than about 0.2 square millimeter. A small area device may be, for example, 0.3 mm by 0.4 mm. The device illustrated in FIG. 1 may be, for example, 1 mm on a side. The device shown in FIG. 1 is described in more detail in application Ser. No. 09/469,657, titled "III-Nitride Light-Emitting Device With Increased Light Generating Capability," filed Dec. 22, 1999 on an invention of Krames et al., and incorporated herein by reference. The device shown in FIG. 1 has a single, large n-contact and a single, large p-contact.

[0024] Because of the high resistivity of the p-type layers, III-nitride light emitting devices employ a metal layer overlying the p-type layers to provide p-side current spreading. When both contacts are formed on the same side of the device, the n-side current spreading must occur through the n-type III-nitride layers. In III-phosphide devices formed on conducting substrates, n-side current spreading may also occur through the substrate. In both III-nitride and III-phosphide devices, the distance over which current spreading within the semiconductor is required should be minimized, since requiring current spreading over large distances causes higher resistance and less uniform current density. Increased driving voltages must be applied to the devices in order to get the required current density at every point in the n-type layers. In the III-nitride device shown in FIG. 1, for example, the distance required for current spreading by the n-type layer may be kept less than about 200 microns, meaning no part of the p-contact is more than 200 microns from the nearest part of the n-contact

[0025] Current spreading can be a particular problem in the case of large area devices, in which the current in the lower semiconductor layers must spread some considerable lateral distance. In order to circumvent this problem, the concept of using the current spreading fingers as shown in FIG. 1 has been proposed. However, in devices with current spreading fingers on the n-contact as shown in FIG. 1, considerable active region must be sacrificed in order to provide fingers for increased current spreading. In small area chips, i.e. devices with an area less than 0.2 square millimeter, efficient current spreading may be less of an issue

than in large area chips. However, LED active region area must still be sacrificed in order to make contact to the semiconductor layer. Typically, the minimum absolute area required to make such a contact would be fixed by the minimum size to which it is possible to make electrical contact to the chip. In the case of a flip chip, the minimal manufacturable size of a solder bump would determine the minimum size of the underlying contact area. In the case of an epi-up structure, the minimum area to which wire bonds could be made reproducibly would determine this minimum contact area. Therefore, as the area of LED chips decrease, the fractional area of the chip required to make the contact to the n-type semiconductor layer increases and the fractional active region area of the LED decreases.

[0026] FIG. 2 illustrates a plan view of an example of an LED formed in accordance with the present invention. Rather than using a single, large n-contact as shown in the device in FIG. 1, the device of FIG. 2 makes contact to the n-layer of the device through a series of vias 14 which are etched through the active region and the p-layers of the device.

[0027] FIG. 3 is a cross section of the device shown in FIG. 2, taken through axis A. In FIGS. 2 and 3 only the semiconductor layers, and not metal contacts, are shown for clarity. As shown in FIG. 3, one or more n-type layers 11 are formed over a substrate 10. An active region 12 is formed over the one or more n-type layers and one or more p-type layers 13 are formed over the active region. Several vias 14 are formed in the device down to n-type layers 11 by etching away p-type layers 13 and active region 12 with, for example, a reactive ion etch; by ion implantation; by dopant diffusion; or by selective growth of active region 12 and p-type layers 13. The diameter (dimension a in FIG. 3) of the via may be, for example, between about 2 microns and about 100 microns, and is usually between about 10 microns and about 50 microns. The spacing between vias (dimension b in FIG. 3) may be, for example, about 5 microns to about 1000 microns, and is usually about 50 microns to about 200 microns. The device illustrated in FIG. 2 has a 4x4 rectangular array of vias. A rectangular array of a different size (for example, 6x6 or a 9x9) may also be used, as well as a hexagonal array, a rhombohedral array, a face-centered cubic array, an arbitrary arrangement, or any other suitable arrangement.

[0028] A p-contact is formed on what remains of p-type layers 13, and n-contacts are deposited in vias 14. The p- and n-contacts are usually selected for low optical absorption of light and low contact resistivity. For a III-nitride device, the p-contact may consist of, for example, Ag, Al, Au, Rh, Pt. A multilayer contact may include a very thin semitransparent ohmic contact in conjunction with a thick reflective layer which acts as a current spreading layer. An optional barrier layer is included between the ohmic layer and the reflective layer. One example of such a p-type multilayer contact is a gold/nickel oxide/aluminum contact. Typical thicknesses for this type of contact are 30 angstroms of gold, 100 angstroms of nickel oxide, and 1500 angstroms of aluminum. The n-contact of a III-nitride device may be, for example, Al, Ag, or a multilayer n-type III-nitride multilayer contact is titanium and aluminum with typical thicknesses of 30 angstroms of titanium and 1500 angstroms of aluminum. For a III-phosphide device, the p-contact may be, for example, Au:Zn, Au:Be, Al, Pt, Pd, Rh, or Ag. The

n-contact of a III-phosphide device may be, for example, Au:Te, Au:Sn, Au:Ge, Ag, Al, Pt, Rh, or Pd.

[0029] FIGS. 4A-4E illustrate an embodiment of the present invention at various stages during fabrication. In FIG. 4A, one or more n-type layers 11 are deposited epitaxially on a substrate 10. N-type layers 11 may include, for example, a buffer layer, a contact layer, an undoped crystal layer, and n-type layers of varying composition and dopant concentration. N-type layers may be deposited by, for example, MOCVD. An active region 12 is then formed on n-type layers 11. Active region 12 may include, for example, a set of quantum well layers separated by a set of barrier layers. One or more p-type layers 13 are then formed on the active region. P-type layers 13 may include, for example, an electron confining layer, a contact layer, and other p-type layers of various composition and dopant concentration. One or more p-metal layers 20 which will form the electrode or contact to p-type layers 13 is then deposited on p-type layers 13. P-metal 20 may be a highly reflective metal such as, for example, silver. When silver is used as p-metal 20, a thin metal layer for making ohmic contact, such as nickel, is optionally deposited under p-metal 20.

[0030] P-metal 20 is then patterned as shown in FIG. 4B, using for example photolithography along with etching, or a lift-off process. The patterning removes any p-metal 20 that will not be used as a p-contact. The patterning thus removes any p-metal 20 overlying vias 14 shown in FIGS. 2 and 3.

[0031] In FIG. 4C, an optional guard metal layer 50 is deposited over the remaining p-metal 20 and the exposed p-type layers 13. Guard metal layer 50 is used for example when silver is used as p-metal 20. Guard metal layer 50 prevents the silver p-metal from migrating to other parts of the device. Guard metal layer 50 is then patterned and etched in one or more etching steps to form vias 14. Rather than etching, vias 14 may be formed by selectively growing p-type layers 13 such that no p-type layer is grown where the vias are to be located. Or, vias 14 may be formed by implanting or diffusing n-type ions into the p-type region and active region located in the vias to form an n-type region in the vias, rather than etching away the p-type layer and active region in the via locations. Thus, vias 14 are not necessarily openings formed in the p-type layers 13 and the active region 12.

[0032] A dielectric layer 22, such as for example aluminum oxide, is deposited in FIG. 4D to electrically isolate p-metal 20 and guard metal 50 from an n-metal to be deposited in via 14. Dielectric layer 22 may be any material that electrically isolates two materials on either side of dielectric layer 22. Dielectric layer 22 is patterned to remove a portion of the dielectric material covering n-type layer 11 at the bottom of via 14. Dielectric layer 22 must have a low density of pinholes to prevent short circuiting between the p- and n-contacts. In some embodiments, dielectric layer 22 is multiple dielectric layers.

[0033] In FIG. 4E, n-metal 21 is deposited in via 14. Interconnect 15a, which connect the n-metal deposited in each via, may also be deposited at this time.

[0034] Making contact to the n-type layers of a light emitting device using an array of vias 14 as shown in FIG. 2 may offer several advantages. First, the use of vias reduces

the amount of lateral current spreading required in the device by reducing the maximum distance from any point underlying the p-contact to any point underlying the n-contact. Calculations show that the current spreading resistance in the n-type layers of large area LEDs having the n-type layer contacted in an array of vias can be reduced by a factor of 10 to 20. Reduction of the device resistance also reduces the normal operating voltage of the device, which enhances the wall plug efficiency of the device. The wall plug efficiency of a device is defined as the ratio of optical watts out to electrical watts put into the device. Thus, for injection of the same current density through the active region, a device such as that shown in FIG. 2 would require less forward voltage than a device such as that shown in FIG. 1. Furthermore, the reduced distance over which current spreading occurs in the n-type semiconductor layer results in more uniform current density in the active region which leads to more uniform operation and light output of the device. In addition, less resistance means that less heat is generated in the device, which also leads to more efficient light generation through reduced junction temperature. A reduction in heat output may also simplify submount design, since less heat needs to be dissipated by the connection to the submount.

[0035] Second, when vias are used to make contact to the n-type layer instead of a single large contact as shown in FIGS. 1 and 2, the area utilization ratio of the device increases. The area utilization ratio is defined as the ratio of the p-metal area to the surface area of the side of the device on which the contacts are formed. An increase in area utilization ratio means that the device has more active region, since the active region underlies the p-metal, and therefore can generate more light. Also, an increase in area utilization ratio means an increase in the area of the highly-reflective p-contact. Thus, a greater fraction of the light incident on the contact side of the device is incident on the highly-reflective p-contact, thereby decreasing the absorption of the light which is generated within the device. For a 1 square millimeter device using vias for the n-contact, the area utilization ratio may exceed 80%, compared to 68% for a finger-contact scheme as shown in the device of FIG. 1.

[0036] Third, the use of vias instead of a large n-contact can simplify the design of the submount, by making the arrangement of the submount connections to the p-metal and n-metal arbitrary. The ability to make arbitrarily-arranged submount connections is illustrated in FIGS. 5, 6, and 7. FIG. 5 is a plan view of a large junction device (i.e. an area greater than or equal to 0.2 square millimeters) using vias. Vias 14 are interconnected by horizontal interconnections 15a and vertical interconnections 15b. Interconnections 15a and 15b may be, for example, 10 microns wide. FIG. 5 also shows a possible submount connection. Submount connection layers 16 and 17 make electrical connection between the light emitting device and the submount while providing a thermal path for heat removal during operation. Submount connection layers 16 and 17 may be solder layers, or any other type of conductive connection between the submount and the device such as elemental metals, metal alloys, semiconductor-metal alloys, thermally and electrically conductive pastes or compounds (e.g. epoxies), eutectic joints between dissimilar metals between the light emitting device and the submount (e.g. Pd-In-Pd), gold stud-bumps, or solder bumps. Submount connection 16 connects to portions of the p-metal of the device, and submount connection 17

connects to the n-metal deposited in some vias and the interconnects **15a** and **15b** connecting the vias.

[0037] As is shown in **FIG. 5**, the interconnected vias form a grid over the device. Though only the n-metal in vias **14** contact the n-type layer, interconnects **15a** and **15b** are electrically connected to the vias and are thus electrically connected to the n-type layers. Accordingly, both vias **14** and interconnects **15a** and **15b** are available as n-contacts to a submount. Unlike the n-contact shown in **FIG. 1**, vias **14** and interconnects **15a** and **15b** are not confined to a particular area on the chip. Similarly, the grid formed by vias **14** and interconnects **15a** and **15b** encloses an array of nine p-contact sections available as p-contacts to a submount. Like the n-contacts, the p-contact sections are not confined to a particular area on the chip. Thus, since p-contacts and n-contacts are located in many places on the chip, the submount connections are not limited by the shape and location of the p- and n-contacts.

[0038] **FIG. 6** is a cross section of the device shown in **FIG. 5**, taken along axis AA. The n-type layers **11**, active region **12**, p-type layers **13**, and p-metal **20** are formed for example as described above in reference to **FIGS. 4A-4E**. Optional guard layer **50** is omitted for clarity. The vias are isolated from the p-type layers and p-metal contacts by dielectric layer **22**. An n-metal may then be deposited over the entire chip and patterned to form n-contacts **21** in vias **14** and interconnects **15a** and **15b**. A horizontal interconnect **15a** is shown in **FIG. 6**. A second dielectric layer **23** is then deposited over the chip. The second dielectric layer **23** is patterned to create a first set of openings aligned with p-metal regions **20** on the side of the device underlying submount connection **16**, and a second set of openings aligned with vias **14** and interconnects **15a** and **15b** on the side of the device underlying submount connection **17**. Since submount connection **16** is the p-contact to the submount, dielectric layer **23** isolates submount connection **16** from interconnects **15a** and **15b**. Since submount connection **17** is the n-contact to the submount, dielectric layer **23** is removed from the interconnects and vias underlying layer **17** such that submount connection **17** can make electrical contact with vias **14** and interconnects **15a** and **15b**.

[0039] **FIG. 7** is a cross section of the device shown in **FIG. 5**, taken along axis BB. Submount connection **16** is to make contact to p-metal **20**, thus in the area directly underlying submount connection **16**, all of dielectric layer **23** is removed, except the portion covering vertical interconnects **15b**. Submount connection **17** is to make contact to the n-metal and interconnects, thus in the area underlying submount connection **17** dielectric layer **23** is removed only from the top surface of vertical interconnects **15b**. P-metal layer **20** is thus isolated from submount connection **17** by dielectric layer **23**. Submount connections **16** and **17** need not be deposited as shown in **FIG. 5**. Other configurations are possible by properly patterning dielectric layer **23**.

[0040] The ability to make arbitrary connections to the submount provides several advantages. Large conductive submount connections as shown in **FIG. 5** may be easier and cheaper to deposit on the device than one or multiple smaller submount connections. For example, in the device shown in **FIG. 5**, solder layers can easily be deposited for submount connections **16** and **17** by screen or stencil printing. In contrast, the device shown in **FIG. 1** requires solder bumps

in order to contact the n-electrode. Solder bumps are costly and require tight manufacturing tolerances. Screen printing solder is comparatively cheaper and simpler. Also, large conductive submount connections dissipate more heat from the LED flip chip than smaller connections. As is known in the art, cooler light emitting devices typically generate more light than warmer devices and offer improved operation lifetime.

[0041] **FIG. 8** is a plan view of a small junction device (i.e. an area less than one square millimeter) using vias. **FIG. 9** is a cross section of the device shown in **FIG. 8**, taken along axis CC. The device shown in **FIGS. 8 and 9** has a single via **14** etched down to n-type layer **11**. An n-contact **21** is deposited in via **14**. N-via **14** is located at the center of the device to provide improved uniformity of current and light emission. A highly reflective p-contact **20** is deposited on p-type layer **13**. An optional guard metal layer **50** covers reflective p-contact **20**, and a thick p-metal layer **20a** is deposited over guard metal layer **50**. N-contact **21** is separated from the three p-metal layers **20**, **50**, and **20a** by one or more dielectric layers **22**. A p-submount connection **16** connects to p-metal layer **20a** and an n-submount connection **17** connects to n-metal layer **21**, for connecting the device to a submount.

[0042] As illustrated in **FIG. 8**, the device is connected to a submount by three submount connections, two p-submount connections **16** and one n-submount connection **17**. N-submount connection **17** may be located anywhere within n-contact region **21** (surrounded by insulating layer **22**) and need not be located directly over via **14**. Similarly, p-submount connections **16** may be located anywhere on p-metal layer **20a**. As a result, the connection of the device to a submount is not limited by the shape or placement of p-contact **20a** and n-contact **21**.

[0043] In large or small junction devices, vias may be used in conjunction with larger contacts. **FIG. 15** is a plan view of a small junction device. **FIG. 14** is a cross section along axis DD of the device shown in **FIG. 15**. As illustrated in **FIG. 15**, a device may include one or more vias **21** together with a continuous n-contact ring **25** surrounding the active region. **FIG. 14** illustrates that via **21** and ring **25** are electrically connected by interconnect **15a**. Ring **25** reduces the distance current must spread laterally and hence reduces the series resistance of the device. The device illustrated in **FIGS. 14 and 15** shows a small junction device with a single via. Ring **25** from **FIGS. 14 and 15** may also be used in large junction devices with more than one via **21**.

[0044] Although the examples above describe the interconnects between the light emitting device die and the submount as being solder, any suitable interconnect may be used. For example, the interconnects may be elemental metals, metal alloys, semiconductor-metal alloys, solders, thermally and electrically conductive pastes or compounds such as epoxy, eutectic joints such as Pd-In-Pd, Au stud bumps, or solder bumps.

[0045] **FIG. 10** is an exploded view of a packaged light emitting device. A heat-sinking slug **100** is placed into an insert-molded leadframe **106**. The insert-molded leadframe **106** is, for example, a filled plastic material molded around a metal frame that provides an electrical path. Slug **100** may include an optional reflector cup **102**. The light emitting device die **104**, which may be any of the devices described

herein, is mounted directly or indirectly via a thermally conducting submount **103** to slug **100**. An optical lens **108** may be added.

[0046] **FIG. 12** illustrates an alternative embodiment of a packaged light emitting device. Light emitting device **104**, which may be any of the devices described herein, is mounted on and electrically connected to a submount **103**, which is placed in a housing **136**. Electrical leads **132** connect the positive and negative terminals of submount **103** to the positive and negative terminals **130** of the package. A lens **134** may cover light emitting device **104**. Lens **134** and housing **136** may be formed of, for example, transparent epoxy.

[0047] **FIG. 11** illustrates a cross sectional view of multiple LEDs mounted on a board. LEDs **104**, which may be any of the devices described herein, are connected to a board **120** by interconnections **122**. Interconnections **122** may be, for example, solder. Traces **124** on board **120** electrically connect LEDs **104**.

[0048] **FIG. 13** illustrates a cross sectional view of an embodiment of the invention which includes a wavelength converting layer **1300**. Wavelength-converting layer **1300** may be a fluorescent material such as a phosphor. Wavelength-converting layer **1300** absorbs light emitted from active region **12** and converts the wavelength of that light. The conversion efficiency of a wavelength-converting material such as phosphor in a device such as that shown in **FIG. 13** depends on the reflectivity of contacts **20** and **21**. Wavelength-converting layer **1300** emits light isotropically, hence a large fraction of the wavelength-converted light is incident on contacts **20** and **21**. Also, light undergoes optical scattering when exiting wavelength-converting layer **1300**, again directing a large fraction of the wavelength-converted light to contacts **20** and **21**. Thus, the higher the overall reflectivity of contacts **20** and **21**, the greater the fraction of light that exits the device.

[0049] The overall reflectivity of a device may be expressed as an area weighted reflectivity. The area weighted reflectivity is the sum of the reflectivity of each contact multiplied by the percentage of the area of the device covered by that contact. A device with a single large n-contact may have, for example, a silver p-contact (92% reflectivity) that covers 50% of the area of the device and an aluminum n-contact (82% reflectivity) that covers 20% of the area of the device. Such a device would have an area weighted reflectivity of $0.92*0.5+0.82*0.2=0.62$. In contrast, a device with multiple n-contacts formed in vias may have a silver p-contact that covers 80% of the device and multiple aluminum n-contacts that cover 2% of the device, for an area weighted reflectivity of $0.92*0.8+0.82*0.02=0.75$. Any area weighted reflectivity over 0.65 may increase the conversion efficiency of a device including a wavelength converting layer.

[0050] Although the present invention is described in connection with certain specific embodiments for instructional purposes, the present invention is not limited thereto. The depictions of various structures in the various diagrams are illustrative. For example, the invention is not limited to III-nitride or III-phosphide devices, and can be used with any device where both the p- and the n-contacts are formed on the same side of the device. Various modifications, adaptations, and combinations of various features of the

described embodiments can be practiced without departing from the scope of the invention as defined in the following claims.

We claim:

1. A light emitting device comprising:
 - a substrate;
 - a layer of first conductivity type overlying the substrate;
 - a light emitting layer overlying the layer of first conductivity type;
 - a layer of second conductivity type overlying the light emitting layer;
 - a plurality of vias formed in the layer of second conductivity type, the plurality of vias extending to the layer of first conductivity type;
 - a plurality of first contacts electrically contacting the layer of first conductivity type through the plurality of vias; and
 - at least one second contact electrically contacting the layer of second conductivity type.
2. The light emitting device of claim 1 wherein the layer of first conductivity type and the layer of second conductivity type comprise gallium and nitrogen.
3. The light emitting device of claim 1 wherein the layer of first conductivity type and the layer of second conductivity type comprise aluminum and phosphorus.
4. The light emitting device of claim 1 wherein each of the plurality of vias has a width ranging from about 2 μm to about 100 μm .
5. The light emitting device of claim 1 wherein each of the plurality of vias has a width ranging from about 10 μm to about 50 μm .
6. The light emitting device of claim 1 wherein each of the plurality of vias is located between about 5 μm to about 1000 μm from another via.
7. The light emitting device of claim 1 wherein each of the plurality of vias is located between about 50 μm to about 250 μm from another via.
8. The light emitting device of claim 1 wherein the plurality of vias are formed in an arrangement selected from the group consisting of rectangular, hexagonal, rhombohedral, face-centered cubic, and arbitrary.
9. The light emitting device of claim 1 further comprising:
 - a first insulating layer formed over the plurality of first contacts and the second contact;
 - a first plurality of openings in the first insulating layer, the first plurality of openings being aligned with the plurality of vias; and
 - a plurality of interconnects formed over the first insulating layer, the plurality of interconnects connecting the plurality of first contacts.
10. The light emitting device of claim 9 further comprising:
 - a second insulating layer formed over the first insulating layer and the plurality of interconnects;
 - at least one first opening in the second insulating layer, the first opening being located on a first portion of the device and being aligned with at least a portion of the second contact; and

- at least one second opening in the second insulating layer, the second opening being located on a second portion of the device and being aligned with at least a portion of the plurality of interconnects and the plurality of vias.
- 11.** The light emitting device of claim 10 further comprising:
- a first submount connection overlying the first portion of the device; and
 - a second submount connection overlying the second portion of the device.
- 12.** The light emitting device of claim 11 further comprising:
- a submount connected to the first submount connection and the second submount connection;
 - a plurality of leads connected to the submount; and
 - a lens underlying the submount.
- 13.** The light emitting device of claim 12 further comprising:
- a heat sink disposed between the leads and the submount.
- 14.** The light emitting device of claim 11 further comprising:
- a board connected to the first submount connection and the second submount connection, wherein the board comprises a trace coupled to one of the first submount connection and the second submount connection.
- 15.** The light emitting device of claim 1 further comprising an insulating layer formed between the layer of second conductivity type and the plurality of first contacts.
- 16.** The light emitting device of claim 1 wherein the second contact comprises a material selected from the group consisting of Ag, Al, Au, Rh, Pt, Au:Zn, Au:Be, and Pd.
- 17.** The light emitting device of claim 1 wherein at least one of the first contacts comprises a material selected from the group consisting of Au:Te, Au:Sn, Au:Ge, Ag, Al, Pt, Rh, and Pd.
- 18.** The light emitting device of claim 1 wherein an area of the second contact comprises at least 75% of an area of the device.
- 19.** The light emitting device of claim 1 further comprising a wavelength converting layer underlying at least a portion of the substrate.
- 20.** The light emitting device of claim 1 wherein the device has an area weighted reflectivity greater than about 0.65.
- 21.** The light emitting device of claim 1 further comprising a ring electrically contacting the layer of first conductivity type, wherein the ring surrounds the light emitting layer.
- 22.** The light emitting device of claim 21 wherein the ring is electrically connected to the plurality of first contacts.
- 23.** A method of forming a light emitting device, the method comprising:
- providing a substrate;
 - forming a layer of first conductivity type overlying the substrate;
 - forming an active region overlying the layer of first conductivity type;
 - forming a layer of second conductivity type overlying the active region;
 - forming a plurality of vias in the layer of second conductivity type, the plurality of vias contacting the layer of first conductivity type;
 - forming a plurality of first contacts, the plurality of first contacts contacting the layer of first conductivity type through the vias; and
 - forming a second contact on the layer of second conductivity type.
- 24.** The method of claim 23 wherein forming a plurality of vias comprises etching away portions of the layer of second conductivity type.
- 25.** The method of claim 24 wherein etching comprises using a reactive ion etch.
- 26.** The method of claim 23 wherein forming a plurality of vias comprises implanting ions of the first conductivity type in portions of the layer of second conductivity type.
- 27.** The method of claim 23 wherein depositing a layer of second conductivity type and forming a plurality of vias comprise selectively growing at least one layer of second conductivity type over portions of the layer of first conductivity type.
- 28.** The method of claim 23 wherein forming a plurality of vias comprises diffusing atomic species of the first conductivity type in portions of the layer of second conductivity type.
- 29.** A light emitting device comprising:
- a substrate;
 - a layer of first conductivity type overlying the substrate;
 - a light emitting layer overlying the layer of first conductivity type;
 - a layer of second conductivity type overlying the light emitting layer;
 - a via formed in the layer of second conductivity type, the via extending to the layer of first conductivity type;
 - a first contact electrically contacting the layer of first conductivity type through the via;
 - a second contact electrically contacting the layer of second conductivity type;
 - a submount interconnect electrically contacting the first contact, wherein at least a portion of the submount interconnect overlies the second contact.
- 30.** The light emitting device of claim 29 further comprising an insulating layer interposing the submount interconnect and the second contact.
- 31.** The light emitting device of claim 29 wherein the submount interconnect comprises solder.
- 32.** The light emitting device of claim 29 further comprising:
- a submount connected to the submount interconnect;
 - a leadframe connected to the submount; and
 - a lens underlying the submount.

33. The light emitting device of claim 32 wherein the leadframe comprises:

- a first polarity lead comprising two legs; and
- a second polarity lead comprising two legs.

34. The light emitting device of claim 32 further comprising:

- a body overlying the submount, wherein the body and the lens comprise transparent epoxy.

35. The light emitting device of claim 29 further comprising:

a board connected to the first submount connection and the second submount connection, wherein the board comprises a trace coupled to one of the first submount connection and the second submount connection.

36. The light emitting device of claim 29 wherein the device has an area less than about 0.2 square millimeter.

37. The light emitting device of claim 29 further comprising a ring electrically contacting the layer of first conductivity type, wherein the ring surrounds the light emitting layer and is electrically connected to the first contact.

* * * * *