

(12) **United States Patent**  
**Turner et al.**

(10) **Patent No.:** **US 12,053,807 B2**  
(45) **Date of Patent:** **\*Aug. 6, 2024**

- (54) **PIPELINE INSPECTION DEVICE**
- (71) Applicant: **MILWAUKEE ELECTRIC TOOL CORPORATION**, Brookfield, WI (US)
- (72) Inventors: **Christopher J. Turner**, Lannon, WI (US); **Gareth Mueckl**, Milwaukee, WI (US); **Samuel J. Krohlow**, Wauwatosa, WI (US)
- (73) Assignee: **MILWAUKEE ELECTRIC TOOL CORPORATION**, Brookfield, WI (US)

(\*) Notice: Subject to any disclaimer, the term of this patent is extended or adjusted under 35 U.S.C. 154(b) by 0 days.

This patent is subject to a terminal disclaimer.

- (21) Appl. No.: **18/117,929**
- (22) Filed: **Mar. 6, 2023**

(65) **Prior Publication Data**  
US 2023/0201893 A1 Jun. 29, 2023

**Related U.S. Application Data**

- (63) Continuation of application No. 17/387,313, filed on Jul. 28, 2021, now Pat. No. 11,623,254, which is a (Continued)
- (51) **Int. Cl.**  
**G03B 37/00** (2021.01)  
**B08B 9/043** (2006.01)  
(Continued)
- (52) **U.S. Cl.**  
CPC ..... **B08B 9/043** (2013.01); **B65H 75/403** (2013.01); **B65H 75/4471** (2013.01); **E03F 7/12** (2013.01)

(58) **Field of Classification Search**  
CPC .. B08B 9/043; B65H 75/403; B65H 75/4471; B65H 75/364; B65H 75/4484; E03F 7/12  
See application file for complete search history.

(56) **References Cited**  
**U.S. PATENT DOCUMENTS**

2,301,104 A 11/1942 Lloyd  
D196,100 S 8/1963 O'Neill  
(Continued)

**FOREIGN PATENT DOCUMENTS**

DE 202005002976 U1 8/2005  
EP 0987541 A1 3/2000  
(Continued)

**OTHER PUBLICATIONS**

Extended European Search Report for Application No. 17881028.9 dated Oct. 13, 2020 (8 pages).  
(Continued)

*Primary Examiner* — John R Schnurr  
(74) *Attorney, Agent, or Firm* — Michael Best & Friedrich LLP

(57) **ABSTRACT**

A hub for use with a pipeline inspection device including a reel and a cable disposed at least partially within the reel, the cable including a camera. The hub includes a body configured to be selectively coupled to the reel, a mating member positioned on the body, where the mating member is configured to removably secure the body to the reel, a wireless communication module positioned within the body, where the wireless communication module is configured to create a wireless connection between the hub and a remote device including a display, a battery receptacle on the body, and a battery removably coupled to the battery receptacle, the battery configured to provide power to the camera.

**20 Claims, 23 Drawing Sheets**

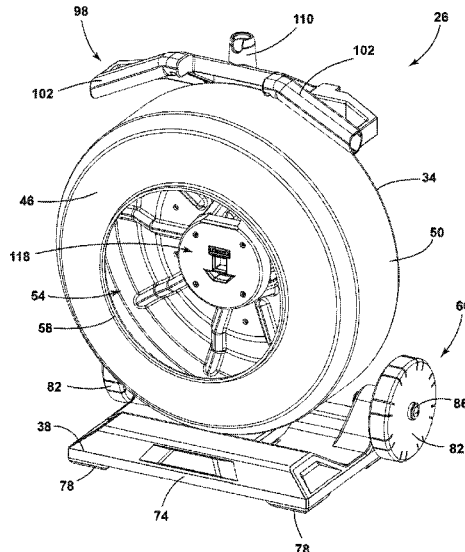

| <b>Related U.S. Application Data</b> |   |              |         |                   |  |
|--------------------------------------|---|--------------|---------|-------------------|--|
|                                      | continuation of application No. 16/591,342, filed on Oct. 2, 2019, now Pat. No. 11,110,495, which is a continuation of application No. 15/844,270, filed on Dec. 15, 2017, now Pat. No. 10,434,547. |              |         |                   |  |
| (60)                                 | Provisional application No. 62/447,102, filed on Jan. 17, 2017, provisional application No. 62/434,786, filed on Dec. 15, 2016.   |              |         |                   |  |
| (51)                                 | <b>Int. Cl.</b>   |              |         |                   |  |
|                                      | <b>B65H 75/40</b> (2006.01)   |              |         |                   |  |
|                                      | <b>B65H 75/44</b> (2006.01)   |              |         |                   |  |
|                                      | <b>E03F 7/12</b> (2006.01)  |              |         |                   |  |
| (56)                                 | <b>References Cited</b>   |              |         |                   |  |
|                                      | U.S. PATENT DOCUMENTS   |              |         |                   |  |
|                                      | 3,400,230 A 9/1968 Becker et al.  | 8,013,610 B1 | 9/2011  | Merewether et al. |  |
|                                      | 3,976,260 A 8/1976 Irik   | 8,033,677 B1 | 10/2011 | Olsson et al.     |  |
|                                      | D257,576 S 12/1980 Bobrovniczky   | 8,035,390 B2 | 10/2011 | Olsson et al.     |  |
|                                      | 4,255,762 A 3/1981 Takeyasu et al.  | 8,074,916 B2 | 12/2011 | Penumatcha et al. |  |
|                                      | D260,985 S 9/1981 Moylan  | 8,106,660 B1 | 1/2012  | Merewether et al. |  |
|                                      | 4,576,097 A 3/1986 Foster   | 8,167,468 B1 | 5/2012  | Olsson et al.     |  |
|                                      | 4,611,360 A 9/1986 Irwin  | 8,172,434 B1 | 5/2012  | Olsson            |  |
|                                      | D286,134 S 10/1986 Schwartz   | 8,176,593 B2 | 5/2012  | Gress et al.      |  |
|                                      | D286,503 S 11/1986 Bobrovniczky   | 8,203,343 B1 | 6/2012  | Olsson et al.     |  |
|                                      | 4,725,883 A 2/1988 Clark, Jr. et al.  | 8,248,056 B1 | 8/2012  | Olsson et al.     |  |
|                                      | 4,913,558 A 4/1990 Wettervik et al.   | 8,264,226 B1 | 9/2012  | Olsson et al.     |  |
|                                      | 4,974,168 A 11/1990 Marx  | 8,279,278 B2 | 10/2012 | Park et al.       |  |
|                                      | 4,987,584 A 1/1991 Doenges  | 8,289,385 B2 | 10/2012 | Olsson et al.     |  |
|                                      | 5,014,925 A 5/1991 Cump   | 8,395,661 B1 | 3/2013  | Olsson et al.     |  |
|                                      | 5,309,595 A 5/1994 Salecker et al.  | 8,400,154 B1 | 3/2013  | Olsson et al.     |  |
|                                      | 5,649,674 A 7/1997 Ciekler  | 8,413,347 B2 | 4/2013  | Gress et al.      |  |
|                                      | 5,754,220 A 5/1998 Smalser, Sr.   | 8,540,429 B1 | 9/2013  | Olsson et al.     |  |
|                                      | 6,457,669 B1 10/2002 Chuang   | 8,547,428 B1 | 10/2013 | Olsson et al.     |  |
|                                      | 6,545,704 B1 4/2003 Olsson et al.   | 8,564,295 B2 | 10/2013 | Olsson et al.     |  |
|                                      | D475,277 S 6/2003 Wu  | 8,587,648 B2 | 11/2013 | Olsson et al.     |  |
|                                      | 6,697,102 B1 2/2004 Olsson et al.   | 8,616,725 B2 | 12/2013 | Olsson et al.     |  |
|                                      | 6,831,679 B1 12/2004 Olsson et al.  | 8,616,734 B2 | 12/2013 | Olsson            |  |
|                                      | 6,846,285 B2 1/2005 Hasegawa et al.   | 8,632,230 B2 | 1/2014  | Olsson et al.     |  |
|                                      | 6,862,945 B2 3/2005 Chapman et al.  | 8,635,043 B1 | 1/2014  | Olsson et al.     |  |
|                                      | 6,889,701 B2 5/2005 Kovacik et al.  | 8,717,028 B1 | 5/2014  | Merewether et al. |  |
|                                      | 6,908,310 B1 6/2005 Olsson et al.   | 8,773,133 B1 | 7/2014  | Olsson et al.     |  |
|                                      | 6,931,149 B2 8/2005 Hagene et al.   | 8,864,326 B2 | 10/2014 | Armer et al.      |  |
|                                      | 6,958,767 B2 10/2005 Olsson et al.  | 8,908,027 B2 | 12/2014 | Kleyn et al.      |  |
|                                      | 7,009,399 B2 3/2006 Olsson et al.   | 8,931,131 B1 | 1/2015  | Feduke            |  |
|                                      | 7,044,623 B2 5/2006 Olsson et al.   | 8,970,211 B1 | 3/2015  | Olsson et al.     |  |
|                                      | 7,104,951 B2 9/2006 Hasegawa et al.   | 8,984,698 B1 | 3/2015  | Olsson            |  |
|                                      | 7,136,765 B2 11/2006 Maier et al.   | 9,019,364 B2 | 4/2015  | Brignac et al.    |  |
|                                      | 7,164,476 B2 1/2007 Shima et al.  | 9,041,794 B1 | 5/2015  | Olsson et al.     |  |
|                                      | 7,221,136 B2 5/2007 Olsson et al.   | 9,057,754 B2 | 6/2015  | Olsson et al.     |  |
|                                      | 7,298,126 B1 11/2007 Olsson et al.  | 9,080,992 B2 | 7/2015  | Olsson et al.     |  |
|                                      | 7,332,901 B2 2/2008 Olsson et al.   | 9,081,109 B1 | 7/2015  | Olsson et al.     |  |
|                                      | 7,336,078 B1 2/2008 Merewether et al.   | 9,082,269 B2 | 7/2015  | Olsson et al.     |  |
|                                      | 7,359,611 B1 4/2008 Kaplan  | 9,091,416 B1 | 7/2015  | Olsson et al.     |  |
|                                      | 7,443,154 B1 10/2008 Merewether et al.  | 9,151,484 B1 | 7/2015  | Olsson et al.     |  |
|                                      | D580,857 S 11/2008 Matthew et al.   | 9,134,255 B1 | 9/2015  | Olsson et al.     |  |
|                                      | 7,498,797 B1 3/2009 Olsson et al.   | 9,134,817 B2 | 9/2015  | Olsson            |  |
|                                      | 7,498,816 B1 3/2009 Olsson et al.   | 9,143,740 B2 | 9/2015  | Hansen et al.     |  |
|                                      | 7,518,374 B1 4/2009 Olsson et al.   | 9,207,350 B2 | 12/2015 | Olsson et al.     |  |
|                                      | 7,551,197 B2 6/2009 Penza et al.  | 9,222,809 B1 | 12/2015 | Olsson et al.     |  |
|                                      | 7,557,559 B1 7/2009 Olsson et al.   | 9,234,812 B2 | 1/2016  | Krywuj            |  |
|                                      | D604,244 S 11/2009 Kovacik et al.   | 9,239,512 B2 | 1/2016  | Foss et al.       |  |
|                                      | 7,619,516 B2 11/2009 Olsson et al.  | 9,277,105 B2 | 3/2016  | Olsson et al.     |  |
|                                      | 7,676,879 B1 3/2010 Rutenberg et al.  | 9,285,109 B1 | 3/2016  | Olsson et al.     |  |
|                                      | 7,715,701 B2 5/2010 Lange   | 9,304,055 B2 | 4/2016  | Hansen et al.     |  |
|                                      | 7,733,077 B1 6/2010 Merewether et al.   | 9,316,387 B1 | 4/2016  | Olsson et al.     |  |
|                                      | 7,741,848 B1 6/2010 Olsson et al.   | D755,726 S   | 5/2016  | Michas            |  |
|                                      | 7,825,647 B2 11/2010 Olsson et al.  | 9,341,740 B1 | 5/2016  | Olsson et al.     |  |
|                                      | 7,830,149 B1 11/2010 Olsson et al.  | 9,372,117 B2 | 6/2016  | Olsson et al.     |  |
|                                      | 7,863,885 B1 1/2011 Olsson et al.   | 9,388,973 B1 | 7/2016  | Olsson et al.     |  |
|                                      | D636,253 S 4/2011 Hatcher et al.  | 9,411,066 B1 | 8/2016  | Olsson et al.     |  |
|                                      | 7,948,236 B1 5/2011 Olsson et al.   | 9,411,067 B2 | 8/2016  | Olsson et al.     |  |
|                                      | 7,990,151 B2 8/2011 Olsson et al.   | 9,416,957 B2 | 8/2016  | Olsson et al.     |  |
|                                      |   | 9,429,301 B2 | 8/2016  | Olsson et al.     |  |
|                                      |   | 9,435,907 B2 | 9/2016  | Olsson et al.     |  |
|                                      |   | 9,448,376 B2 | 9/2016  | Chapman et al.    |  |
|                                      |   | 9,465,129 B1 | 10/2016 | Olsson et al.     |  |
|                                      |   | 9,468,954 B1 | 10/2016 | Olsson et al.     |  |
|                                      |   | 9,477,147 B2 | 10/2016 | Chapman et al.    |  |
|                                      |   | 9,488,747 B2 | 11/2016 | Olsson et al.     |  |
|                                      |   | 9,494,706 B2 | 11/2016 | Olsson et al.     |  |
|                                      |   | 9,506,628 B1 | 11/2016 | Merewether et al. |  |
|                                      |   | 9,512,988 B2 | 12/2016 | Olsson et al.     |  |
|                                      |   | 9,521,303 B2 | 12/2016 | Olsson et al.     |  |
|                                      |   | 9,523,788 B1 | 12/2016 | Olsson et al.     |  |
|                                      |   | 9,571,326 B2 | 2/2017  | Bench et al.      |  |
|                                      |   | 9,574,760 B1 | 2/2017  | Olsson et al.     |  |
|                                      |   | 9,599,740 B2 | 3/2017  | Olsson            |  |
|                                      |   | 9,625,602 B2 | 4/2017  | Olsson            |  |
|                                      |   | 9,632,202 B2 | 4/2017  | Olsson et al.     |  |
|                                      |   | 9,634,878 B1 | 4/2017  | Bench et al.      |  |
|                                      |   | 9,638,824 B2 | 5/2017  | Olsson et al.     |  |
|                                      |   | 9,684,090 B1 | 6/2017  | Olsson et al.     |  |
|                                      |   | 9,695,008 B2 | 7/2017  | Thakare et al.    |  |
|                                      |   | 9,696,447 B1 | 7/2017  | Olsson et al.     |  |

(56)

References Cited

U.S. PATENT DOCUMENTS

9,696,448 B2 7/2017 Olsson et al.  
 9,703,002 B1 7/2017 Olsson et al.  
 9,746,170 B1 8/2017 Armer et al.  
 9,746,572 B2 8/2017 Olsson et al.  
 9,746,573 B1 8/2017 Olsson et al.  
 9,769,366 B2 9/2017 Olsson et al.  
 9,784,837 B1 10/2017 Olsson et al.  
 9,791,382 B2 10/2017 Olsson et al.  
 9,798,033 B2 10/2017 Olsson et al.  
 9,824,433 B2 11/2017 Olsson et al.  
 9,829,783 B1 11/2017 Chapman et al.  
 9,835,564 B2 12/2017 Olsson et al.  
 9,841,503 B2 12/2017 Olsson et al.  
 9,863,590 B2 1/2018 Olsson et al.  
 9,880,309 B2 1/2018 Merewether et al.  
 9,891,337 B2 2/2018 Olsson et al.  
 9,924,139 B2 3/2018 Olsson et al.  
 9,927,368 B1 3/2018 Olsson et al.  
 9,927,545 B2 3/2018 Olsson et al.  
 9,927,546 B2 3/2018 Olsson et al.  
 9,928,613 B2 3/2018 Olsson et al.  
 D815,049 S 4/2018 Temblador et al.  
 9,945,976 B2 4/2018 Olsson et al.  
 9,989,662 B1 6/2018 Olsson et al.  
 10,001,425 B1 6/2018 Olsson et al.  
 10,009,519 B2 6/2018 Olsson et al.  
 10,009,582 B2 6/2018 Olsson et al.  
 10,024,366 B2 7/2018 Kley et al.  
 10,024,994 B1 7/2018 Cox et al.  
 10,031,253 B2 7/2018 Olsson et al.  
 D836,560 S 12/2018 Temblador et al.  
 10,364,125 B2 7/2019 Blair et al.  
 10,434,547 B2 10/2019 Turner et al.  
 11,052,809 B2 7/2021 Weber et al.  
 11,059,695 B2 7/2021 Zahnd et al.  
 11,248,982 B2 2/2022 Krohlow et al.  
 11,623,254 B2\* 4/2023 Turner ..... E03F 7/12  
 348/84  
 2002/0032365 A1 3/2002 Hasegawa et al.  
 2002/0113870 A1 8/2002 Mueckl et al.  
 2002/0154811 A1 10/2002 Katsuta et al.  
 2003/0052967 A1 3/2003 Brunton  
 2004/0054259 A1 3/2004 Hasegawa et al.  
 2005/0193509 A1 9/2005 Rutkowski et al.  
 2005/0275725 A1 12/2005 Olsson et al.  
 2006/0195994 A1 9/2006 Hung  
 2007/0132842 A1 6/2007 Morris  
 2007/0297778 A1 12/2007 Lange  
 2008/0098544 A1 5/2008 Rutkowski et al.  
 2008/0229527 A1 9/2008 Berry  
 2009/0292502 A1 11/2009 Gress et al.  
 2010/0127922 A1 5/2010 Sooy  
 2010/0208056 A1 8/2010 Olsson et al.  
 2011/0098941 A1 4/2011 Duckworth et al.  
 2011/0109437 A1 5/2011 Olsson  
 2012/0069172 A1 3/2012 Hudritsch  
 2012/0147173 A1 6/2012 Lynch  
 2012/0203501 A1 8/2012 Gress et al.  
 2012/0206501 A1 8/2012 Gress et al.  
 2012/0211580 A1 8/2012 Kley et al.  
 2012/0242341 A1 9/2012 Olsson et al.  
 2013/0164567 A1 6/2013 Olsson et al.  
 2013/0214786 A1 8/2013 Hansen et al.  
 2013/0218485 A1 8/2013 Hansen et al.  
 2013/0235271 A1 9/2013 Kasuga et al.  
 2014/0111376 A1 2/2014 Bench et al.  
 2014/0152802 A1 6/2014 Olsson et al.  
 2014/0154535 A1 6/2014 Olsson et al.  
 2014/0159729 A1 6/2014 Olsson et al.  
 2014/0167766 A1 6/2014 Olsson et al.  
 2014/0168407 A1 6/2014 Olsson et al.  
 2014/0176696 A1 6/2014 Chapman et al.  
 2014/0210989 A1 7/2014 Olsson et al.  
 2014/0313316 A1 10/2014 Olsson et al.

2014/0313321 A1 10/2014 Olsson et al.  
 2015/0055005 A1 2/2015 Olsson et al.  
 2015/0077120 A1 3/2015 Olsson et al.  
 2015/0101896 A1 4/2015 Kley et al.  
 2015/0263434 A1 9/2015 Bench et al.  
 2015/0263469 A1 9/2015 Olsson  
 2015/0350506 A1 12/2015 Olsson et al.  
 2015/0355363 A1 12/2015 Merewether et al.  
 2016/0141766 A1 5/2016 Olsson et al.  
 2016/0173829 A1 6/2016 Olsson et al.  
 2016/0187522 A1 6/2016 Olsson et al.  
 2016/0261829 A1 9/2016 Olsson et al.  
 2016/0373619 A1 12/2016 Olsson et al.  
 2017/0015490 A1 1/2017 Olsson et al.  
 2017/0017010 A1 1/2017 Olsson et al.  
 2017/0023492 A1 1/2017 Olsson et al.  
 2017/0024872 A1 1/2017 Olsson et al.  
 2017/0115424 A1 4/2017 Olsson et al.  
 2017/0128989 A1 5/2017 Olsson et al.  
 2017/0130950 A1 5/2017 Olsson et al.  
 2017/0131422 A1 5/2017 Olsson et al.  
 2017/0131423 A1 5/2017 Olsson et al.  
 2017/0131424 A1 5/2017 Olsson  
 2017/0134693 A1 5/2017 Chapman et al.  
 2017/0160420 A1 6/2017 Olsson et al.  
 2017/0163940 A1\* 6/2017 Olsson ..... H04N 23/57  
 2017/0176344 A9 6/2017 Olsson et al.  
 2017/0191651 A1 7/2017 Merewether et al.  
 2017/0200352 A1 7/2017 Olsson et al.  
 2017/0235010 A1 8/2017 Olsson et al.  
 2017/0261196 A1 9/2017 Chapman et al.  
 2017/0261630 A1 9/2017 Olsson et al.  
 2017/0299757 A1 10/2017 Bench et al.  
 2017/0307670 A1 10/2017 Olsson  
 2017/0363764 A1 12/2017 Aldridge et al.  
 2018/0022535 A9 1/2018 Olsson et al.  
 2018/0038093 A1 2/2018 Olsson et al.  
 2018/0085696 A1 3/2018 Morris et al.  
 2018/0128931 A1 5/2018 Olsson et al.  
 2018/0165924 A9 6/2018 Olsson et al.  
 2018/0169719 A1 6/2018 Turner et al.  
 2018/0202940 A1 7/2018 Olsson et al.  
 2018/0231208 A1 8/2018 Chapman et al.  
 2019/0346330 A1 11/2019 Krohlow et al.  
 2021/0164601 A1 6/2021 Warren et al.  
 2021/0250551 A1 8/2021 Turner  
 2021/0354178 A1 11/2021 Turner et al.  
 2022/0085592 A1 3/2022 Olsson et al.  
 2022/0268393 A1 8/2022 Moreau et al.

FOREIGN PATENT DOCUMENTS

EP 2313211 B1 9/2015  
 JP 2010096718 A 4/2010  
 WO 0107954 A1 2/2001  
 WO 2006078873 A9 1/2009  
 WO 2012168736 A1 12/2012  
 WO 2012178205 A2 12/2012  
 WO 2013074705 A2 5/2013  
 WO 2013148714 A2 10/2013  
 WO 2014145778 A1 9/2014  
 WO 2015031407 A1 3/2015  
 WO 2016003938 A1 1/2016  
 WO 2018112476 A1 6/2018  
 WO 2018129549 A1 7/2018  
 WO 2018132772 A1 7/2018

OTHER PUBLICATIONS

Gen-Eye Prism Video Pipe Inspection System, <<https://drainbrain.com/products/gen-eye-prism/>> website available as early as Dec. 14, 2017.  
 YouTube, "How to connect mobile devices to Gen-Eye Wi-Fi—Version 2.0," <<https://www.youtube.com/watch?v=YKncdIIQLA8>> published Sep. 12, 2016.

\* cited by examiner

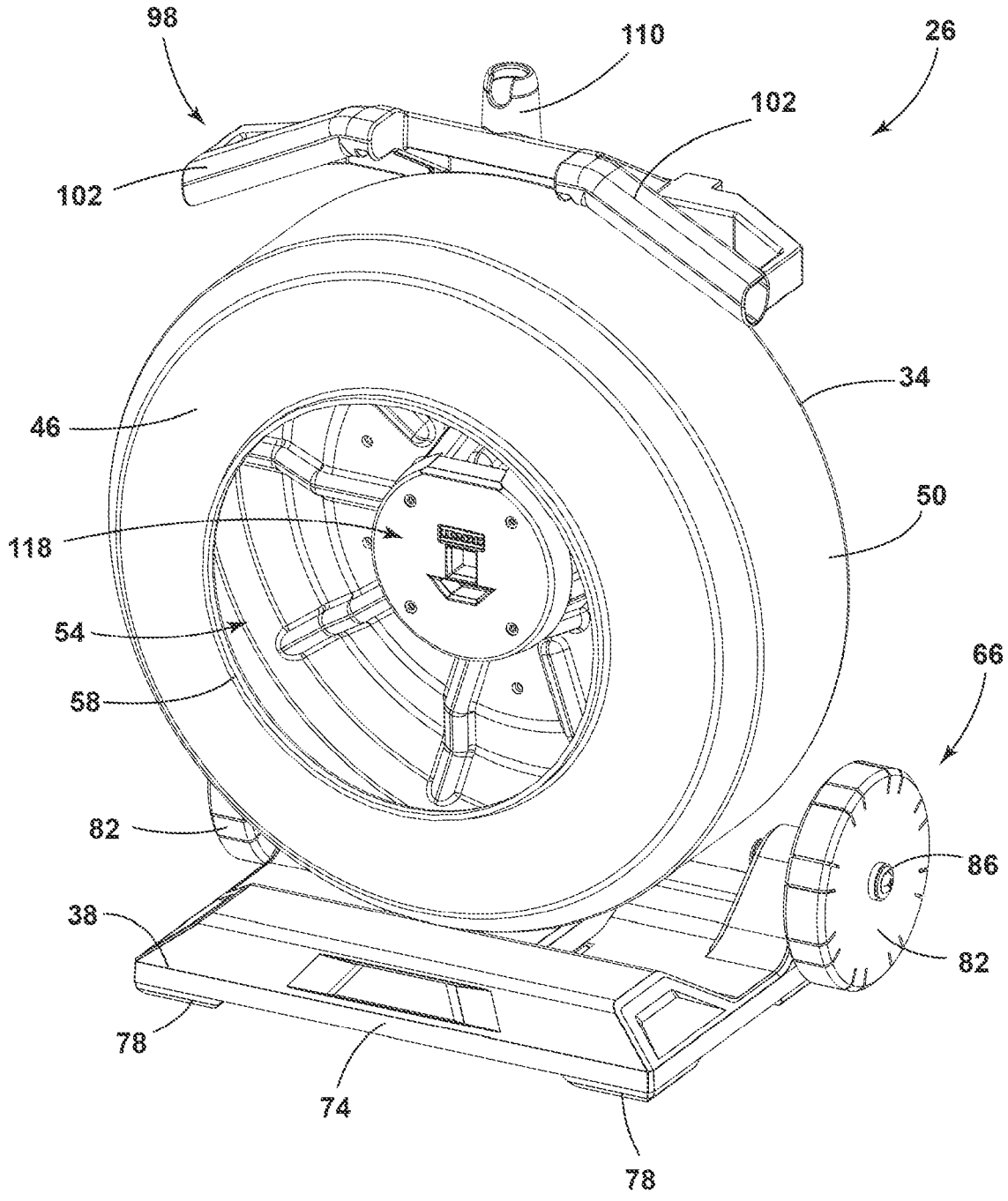

FIG. 1

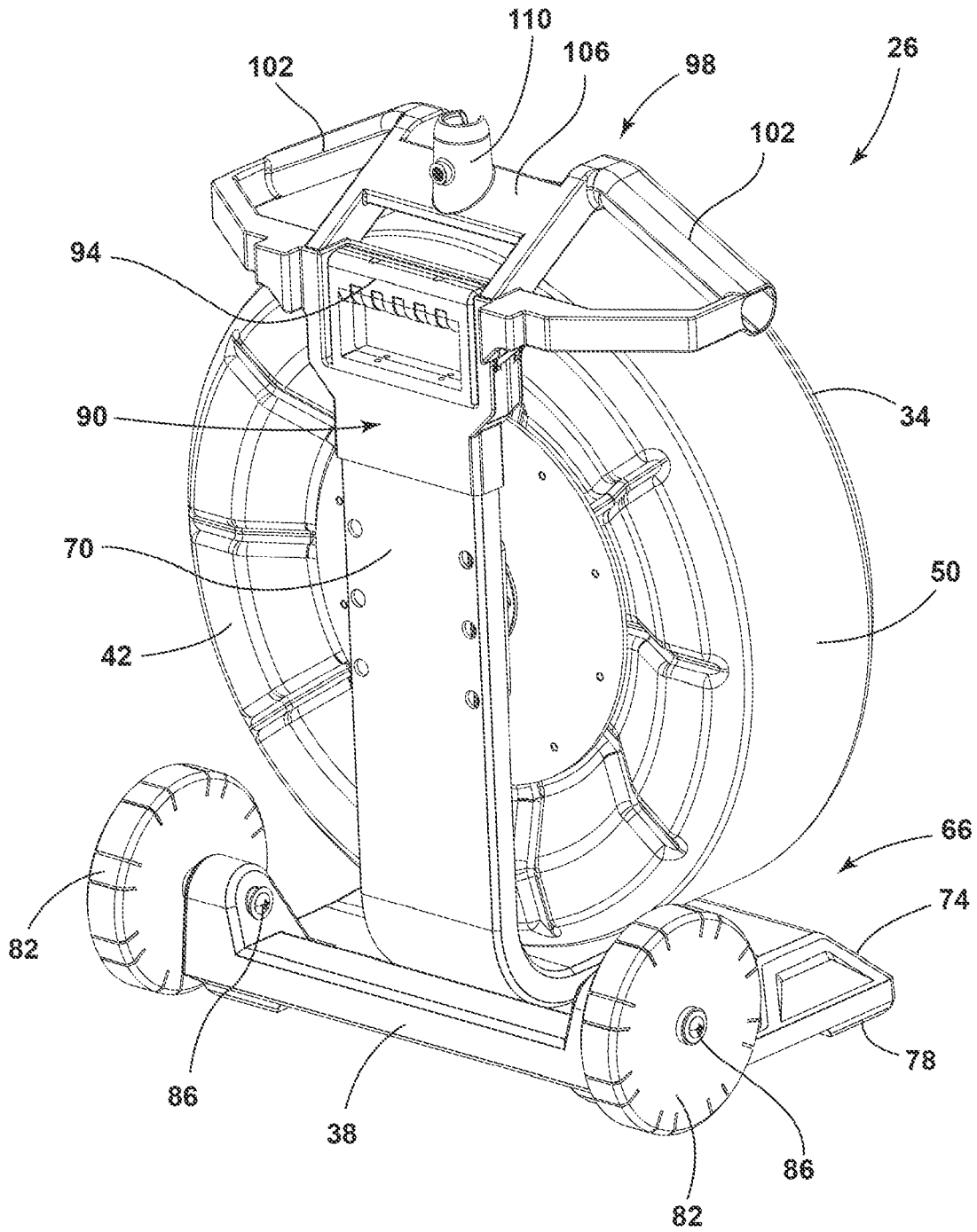

FIG. 2

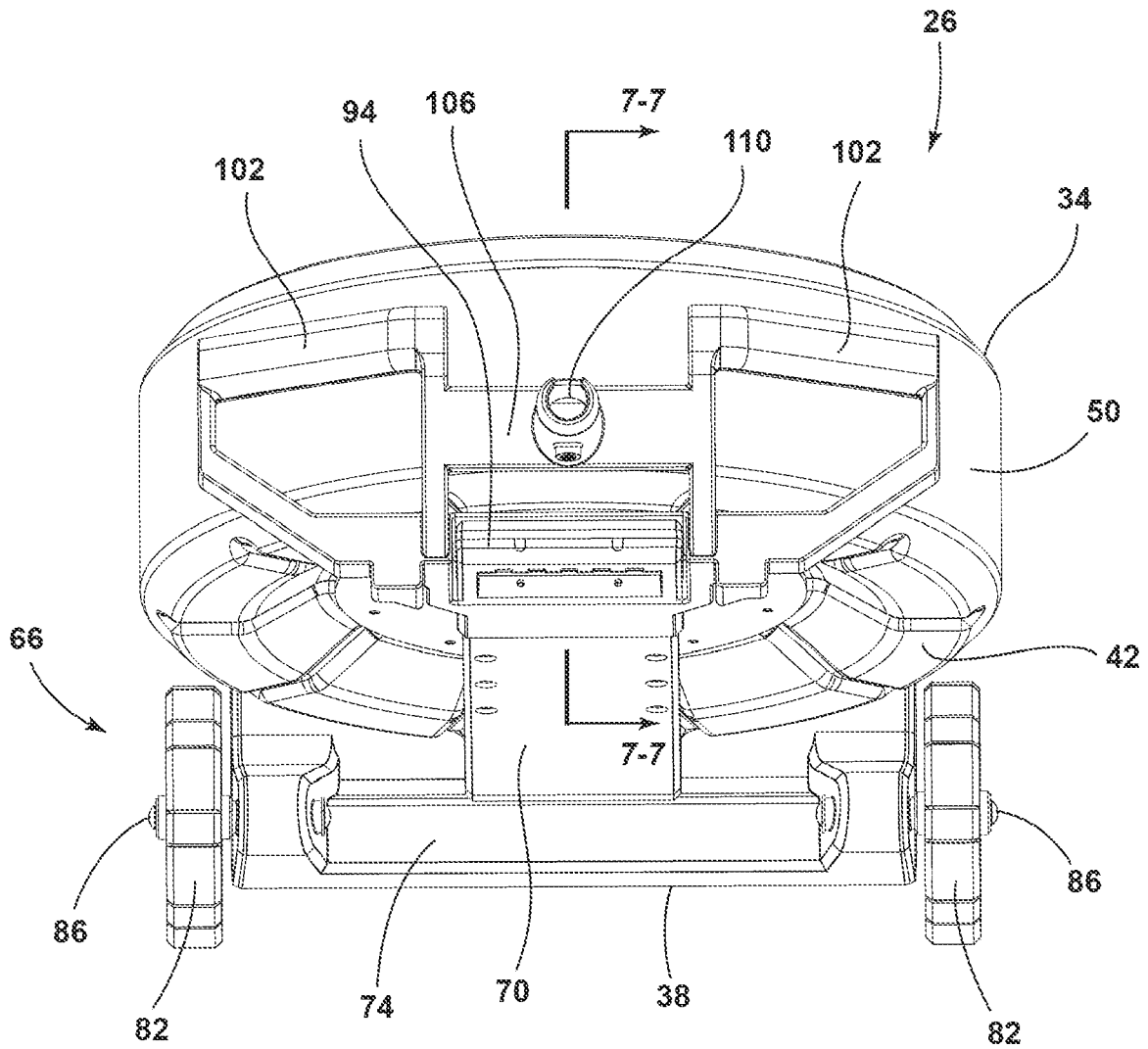

FIG. 3

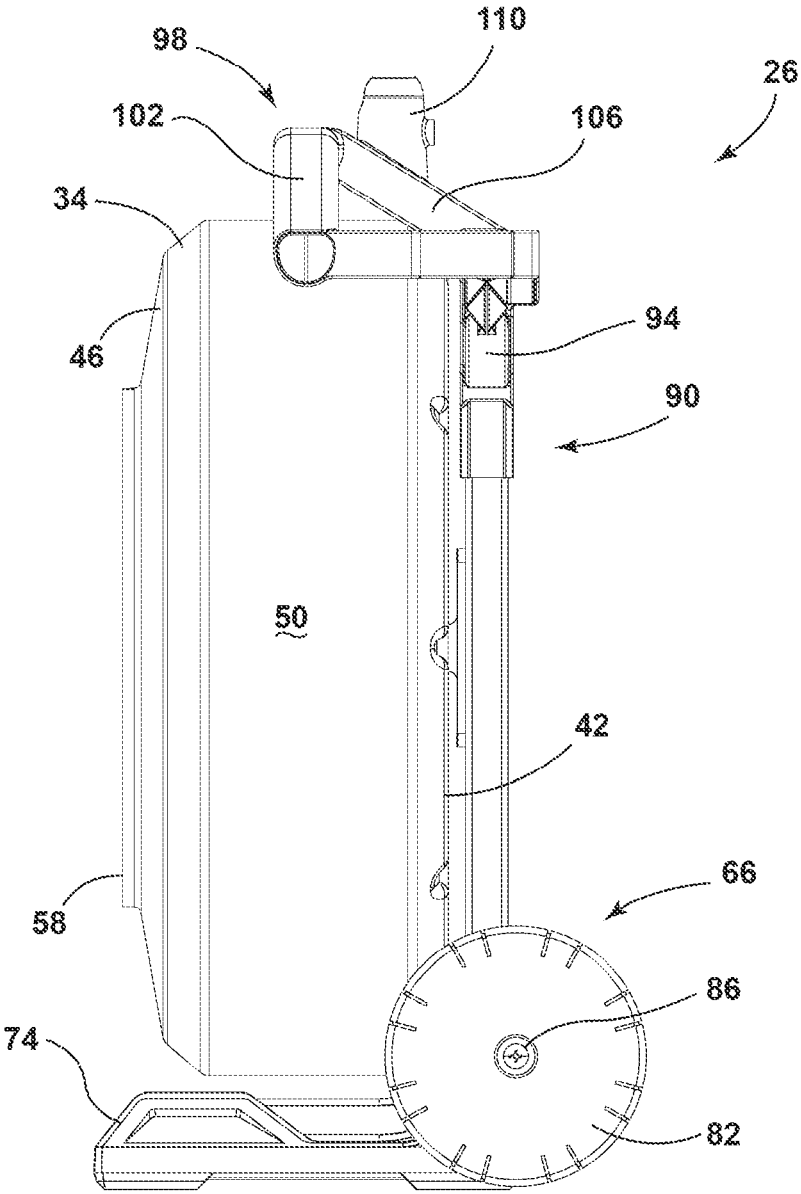

FIG. 4

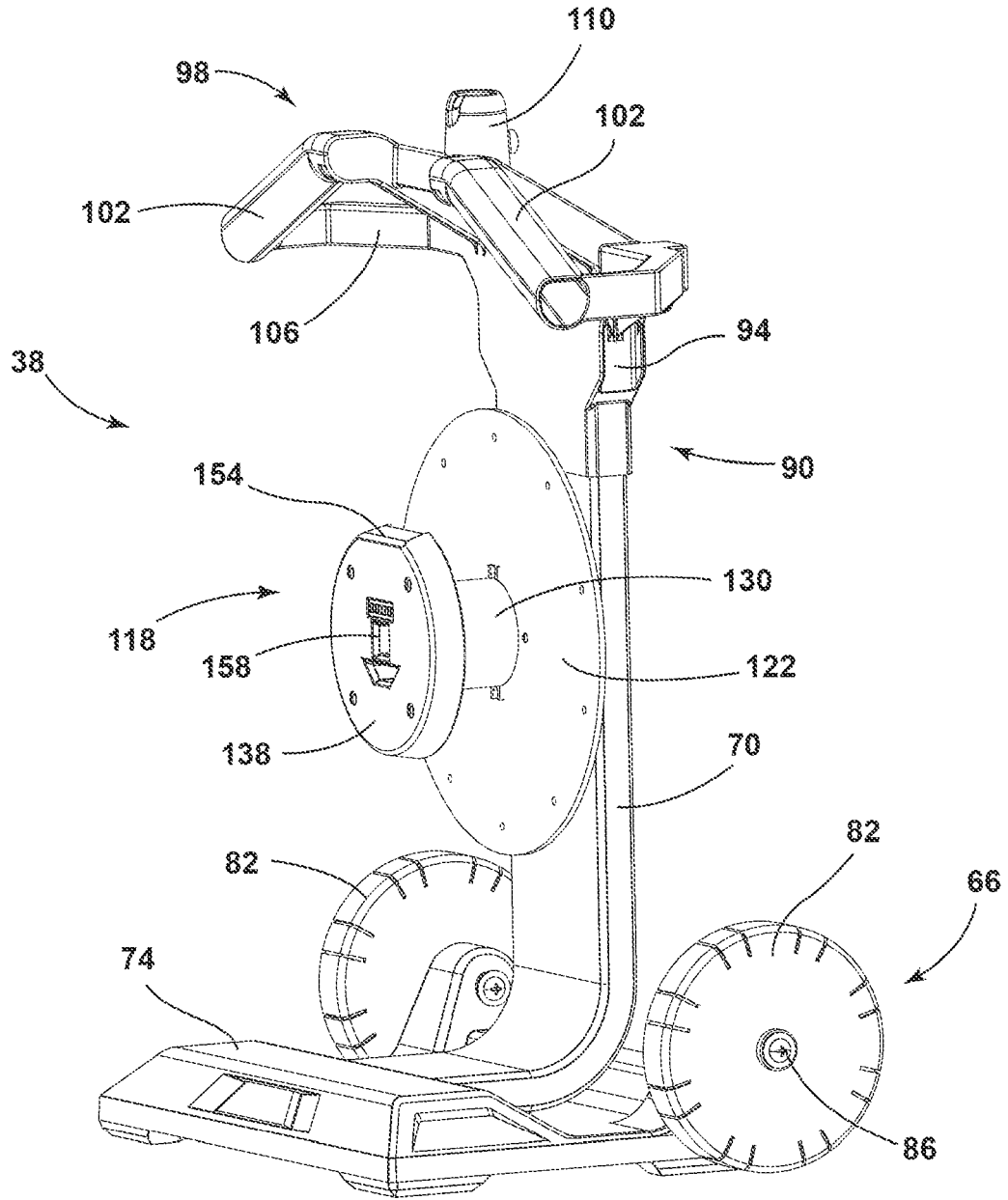

FIG. 5



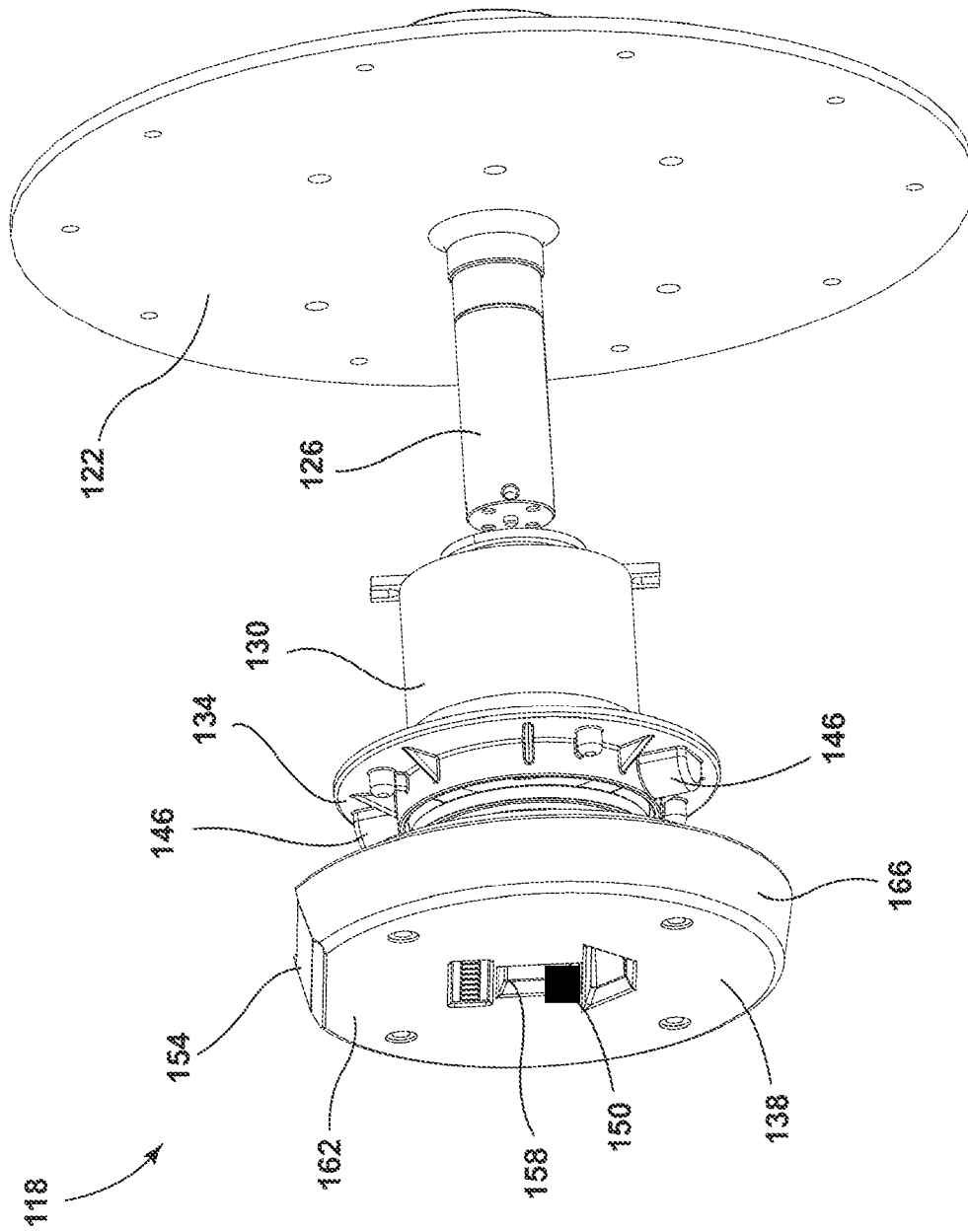

FIG. 6

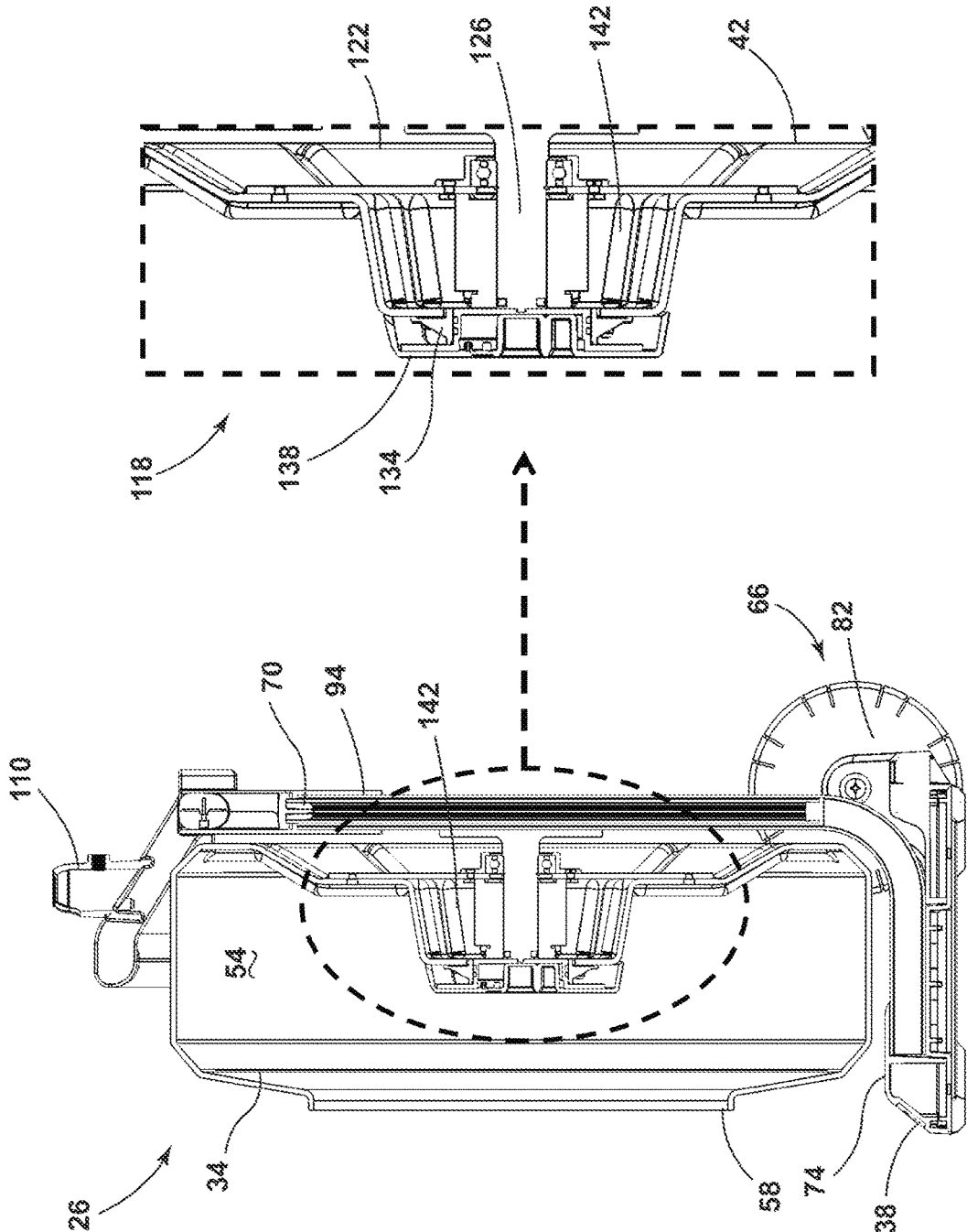

FIG. 7

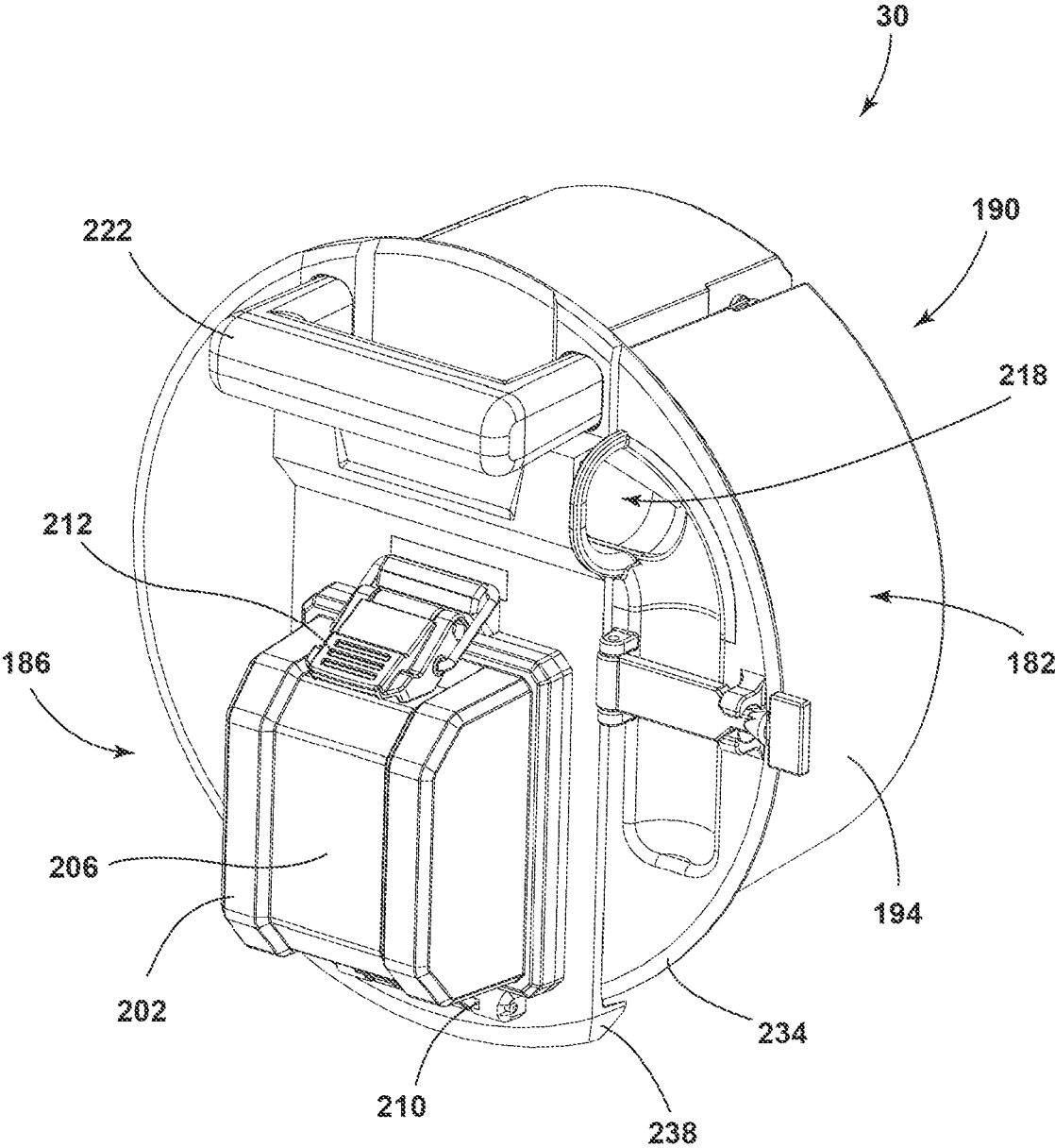

FIG. 8

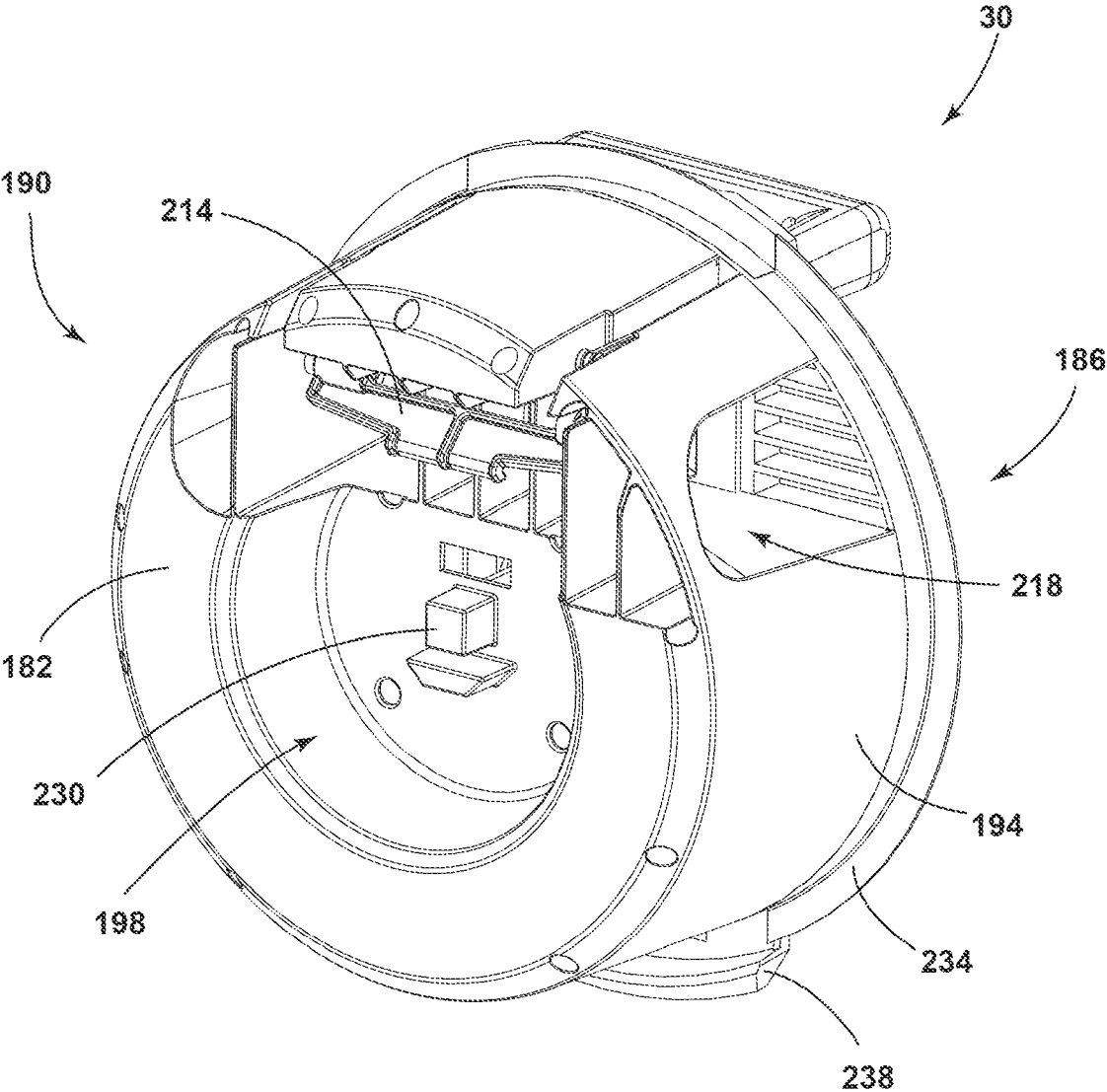

FIG. 9

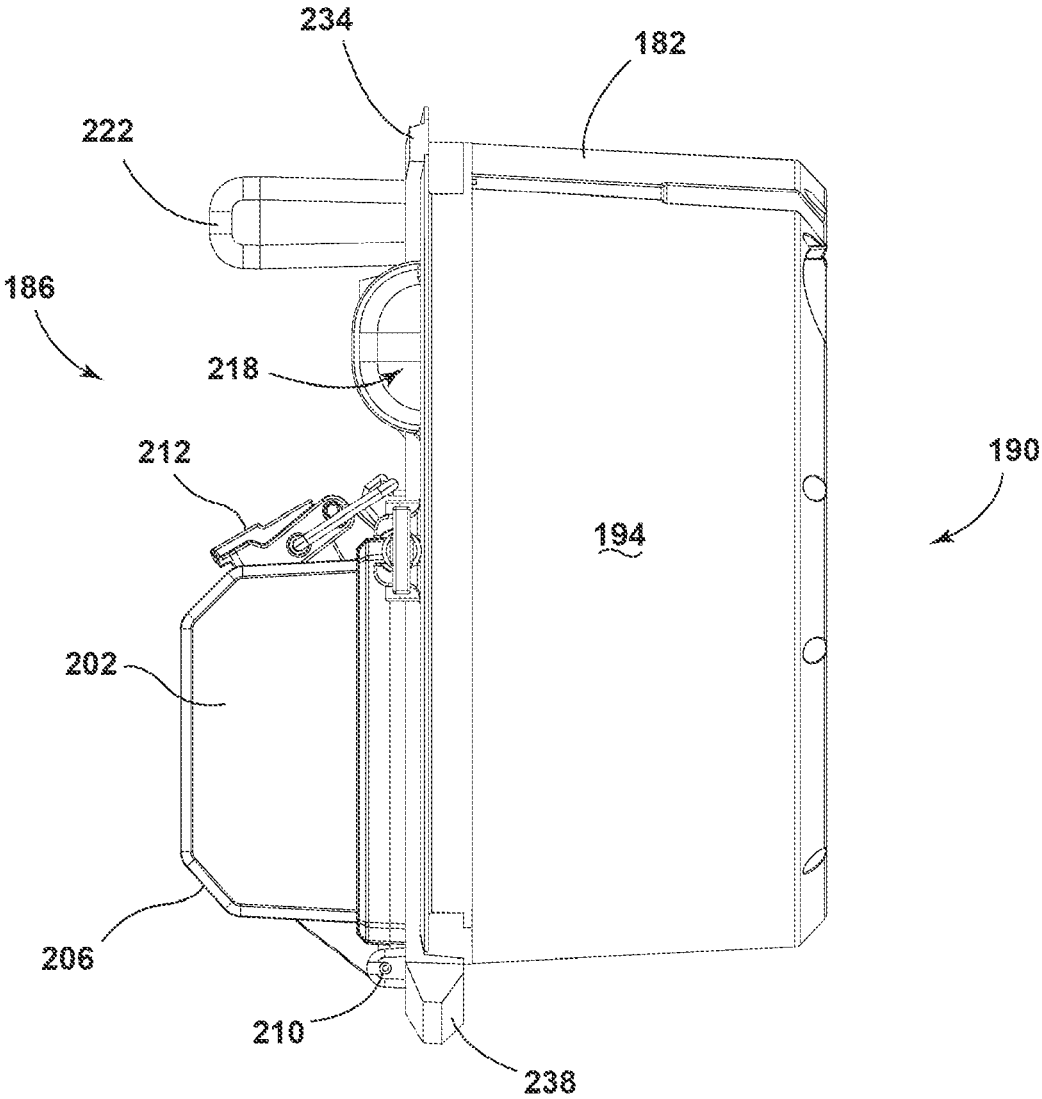

FIG. 10

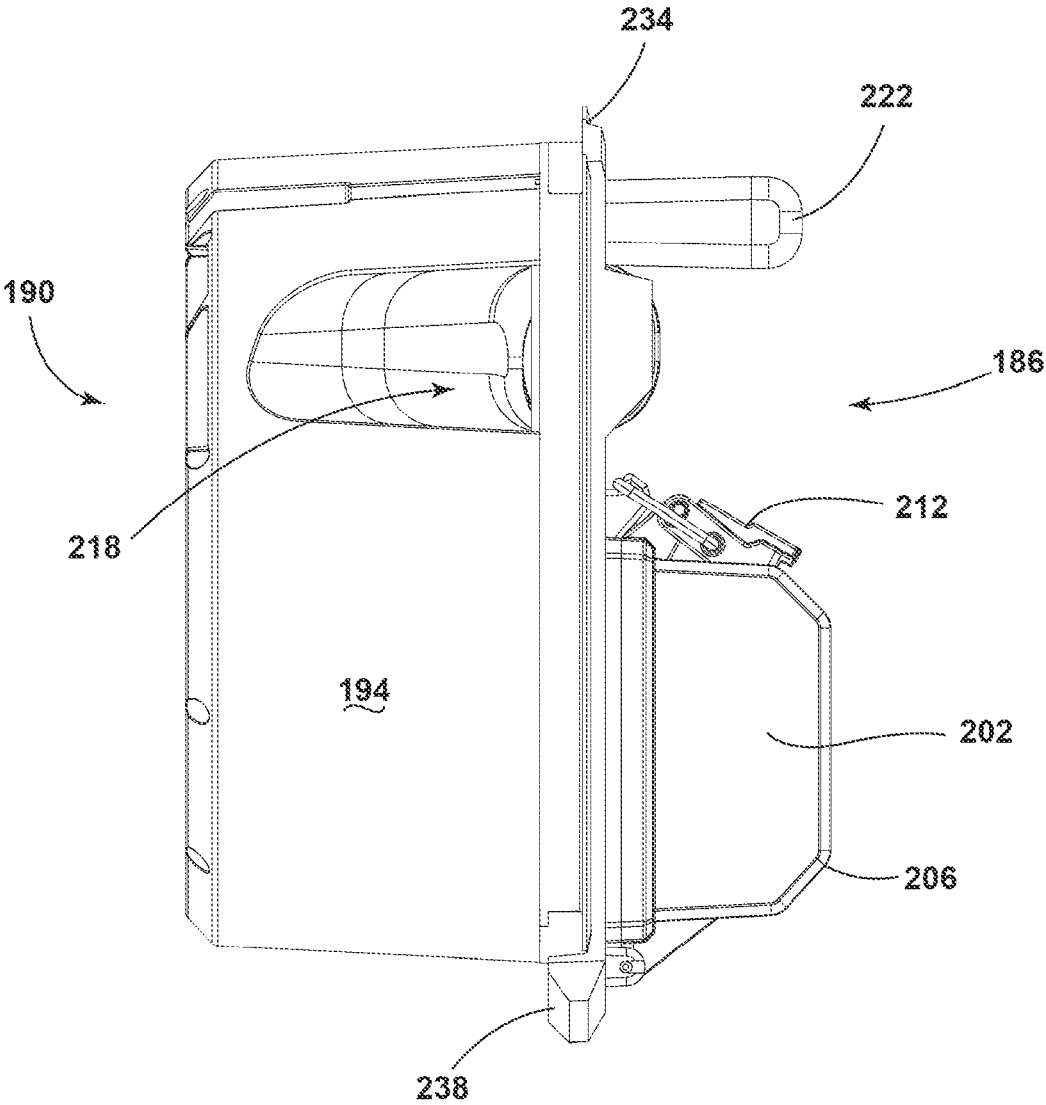

FIG. 11

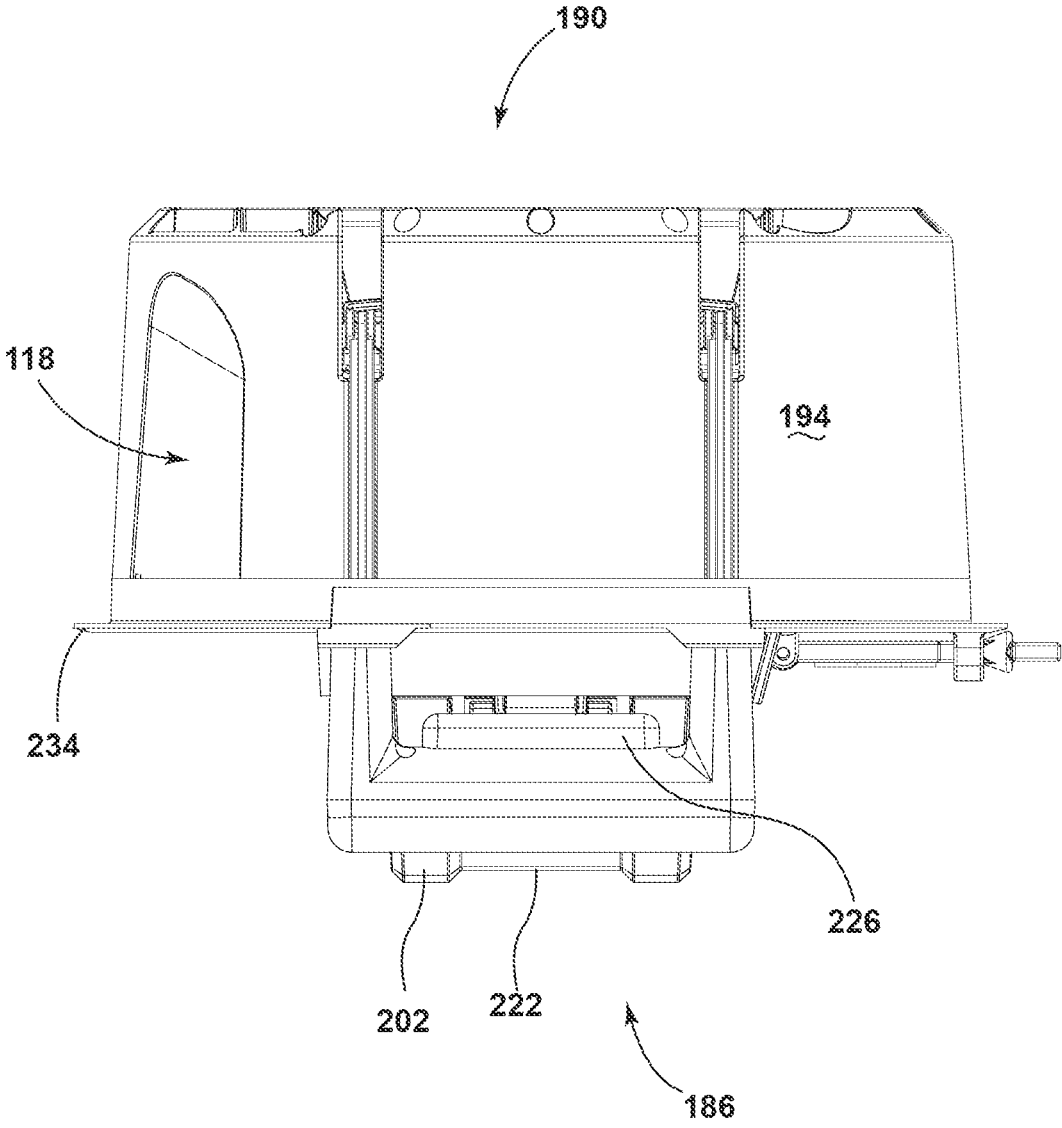

FIG. 12

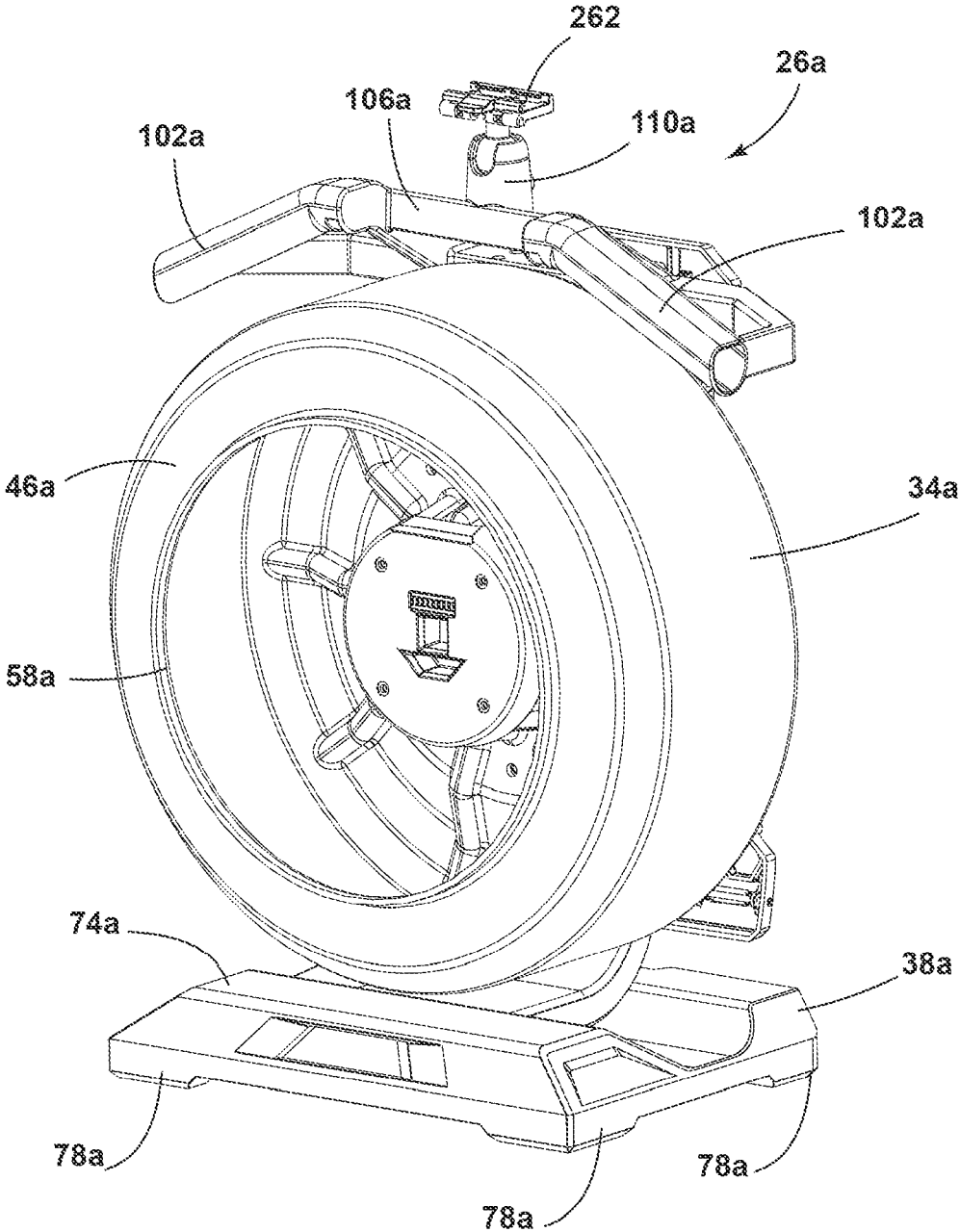

FIG. 13



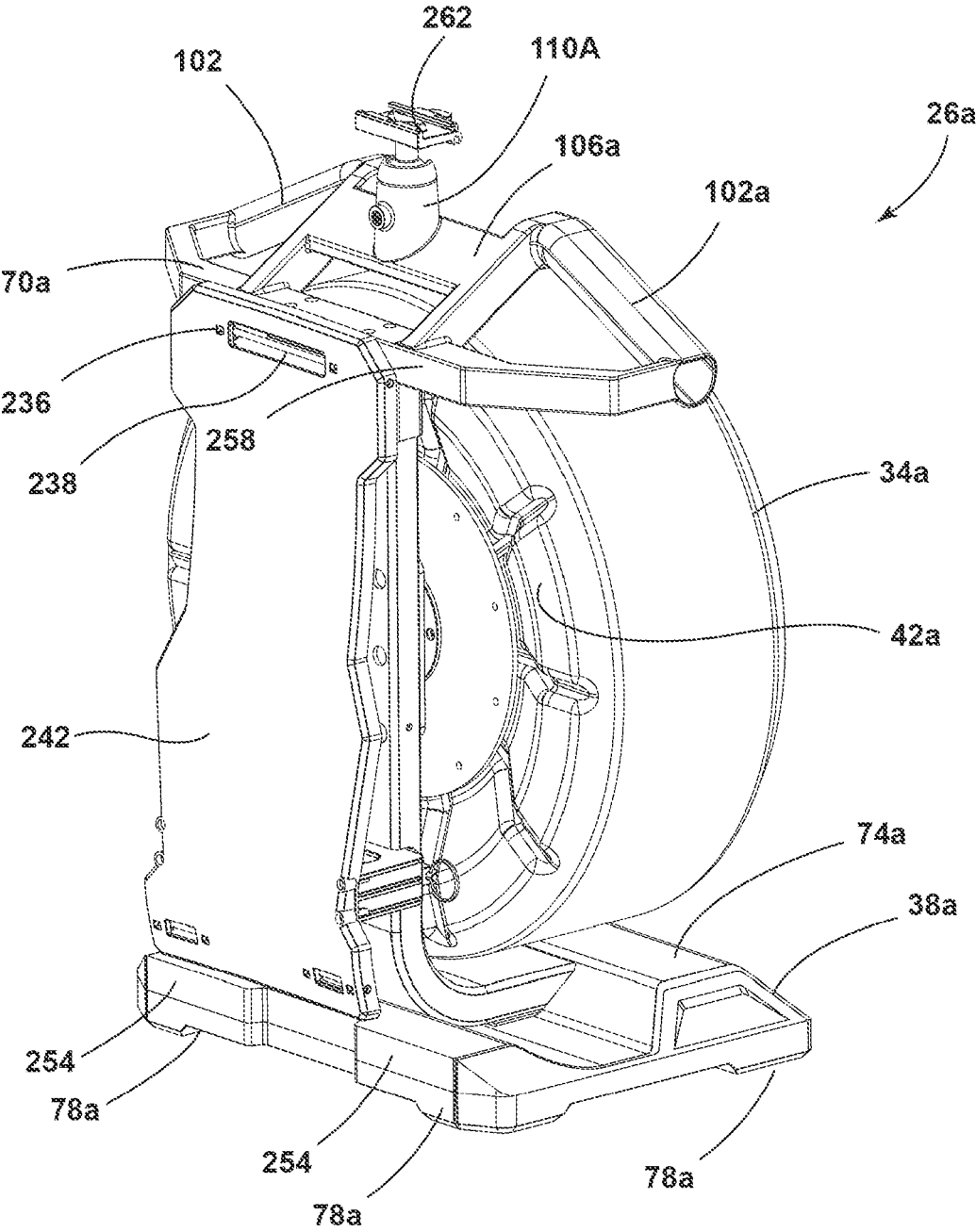

FIG. 14

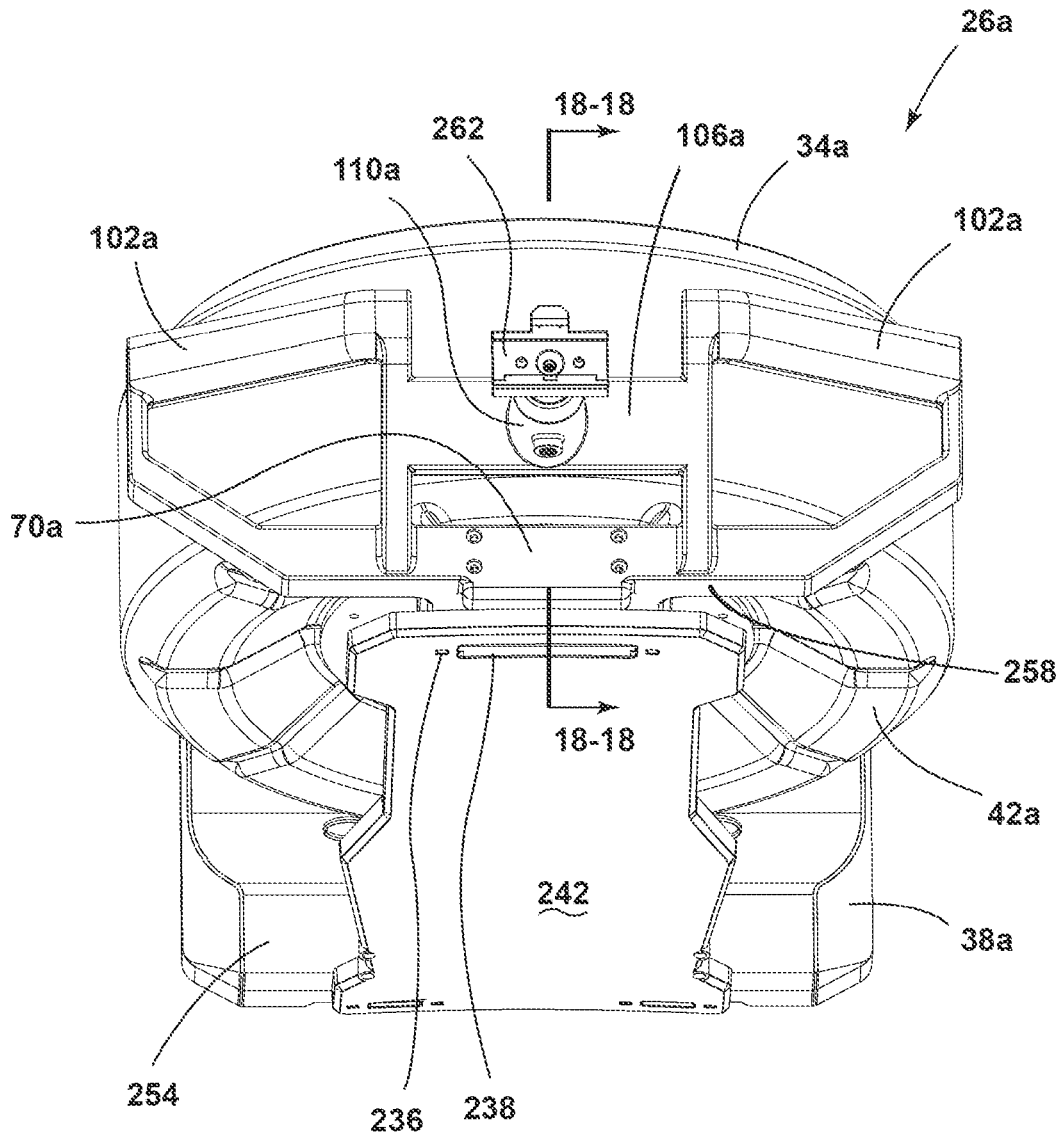

FIG. 15

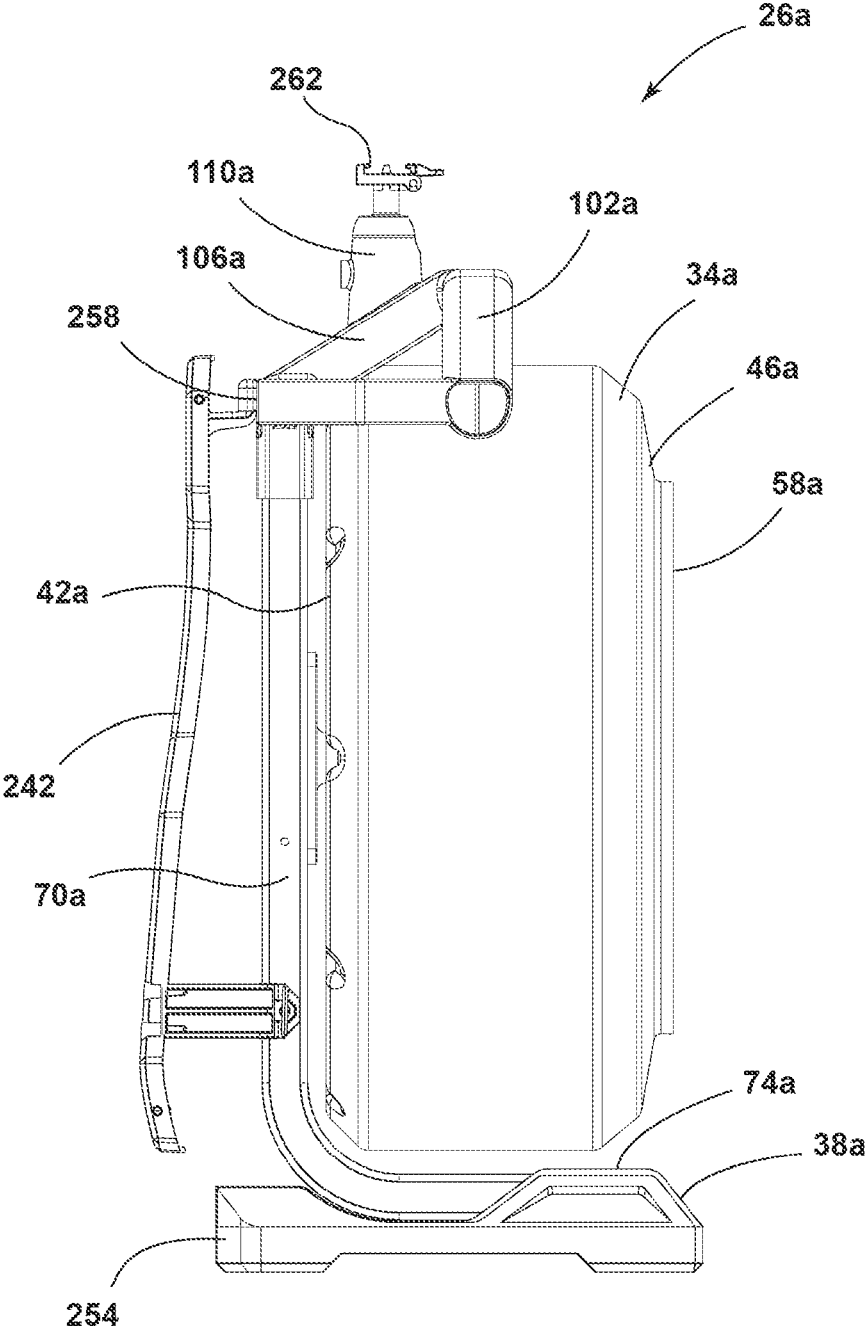

FIG. 16

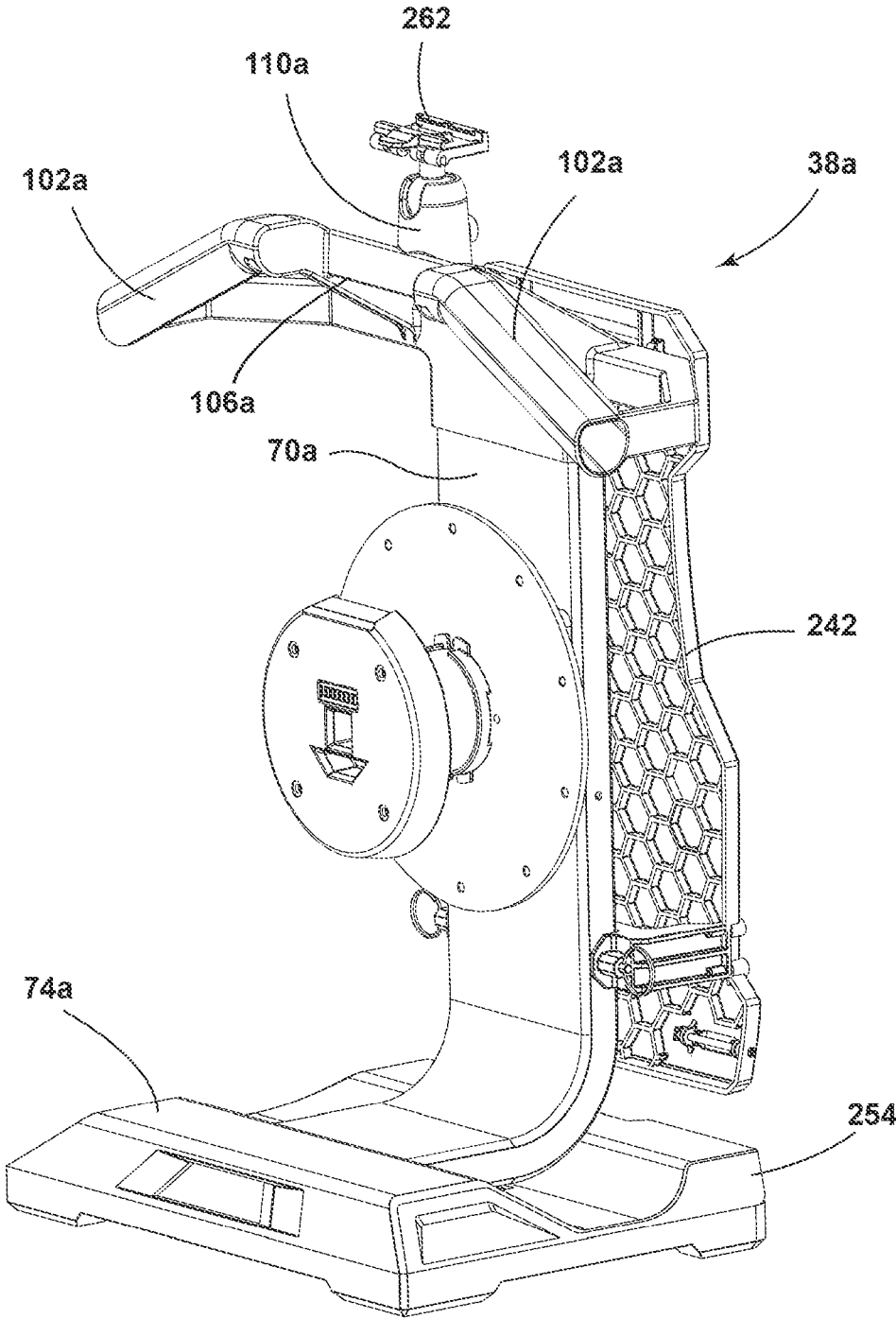

FIG. 17

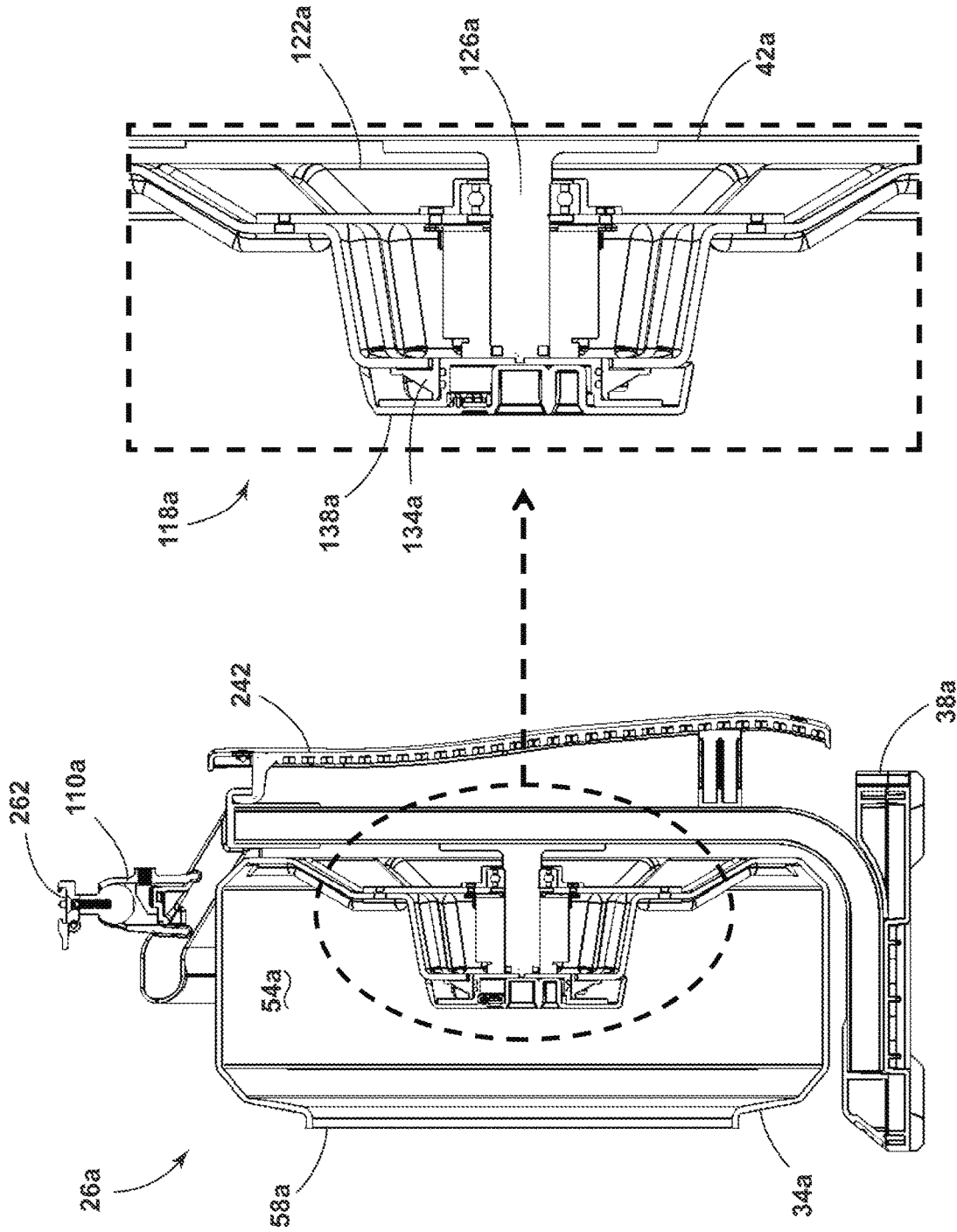

FIG. 18

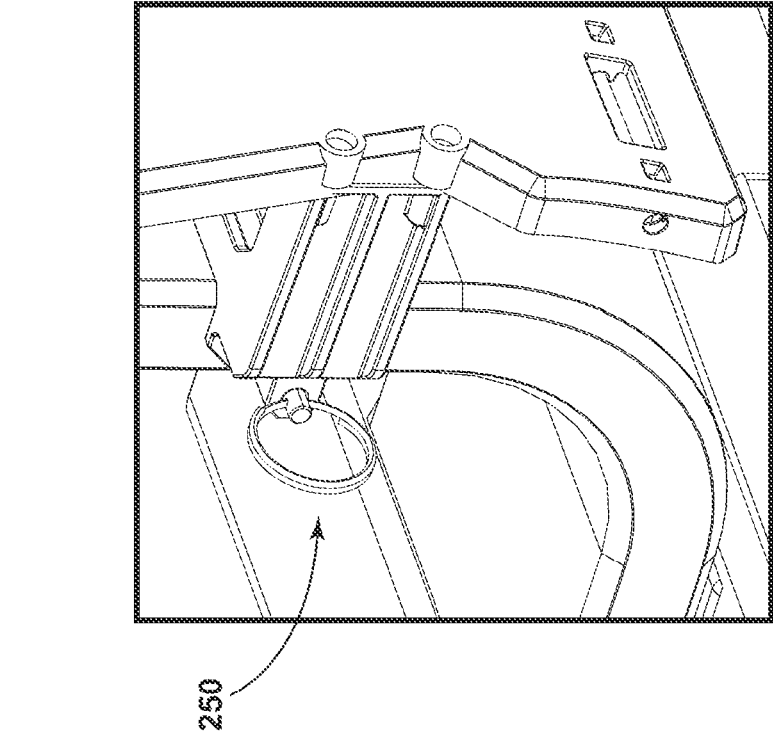

FIG. 19

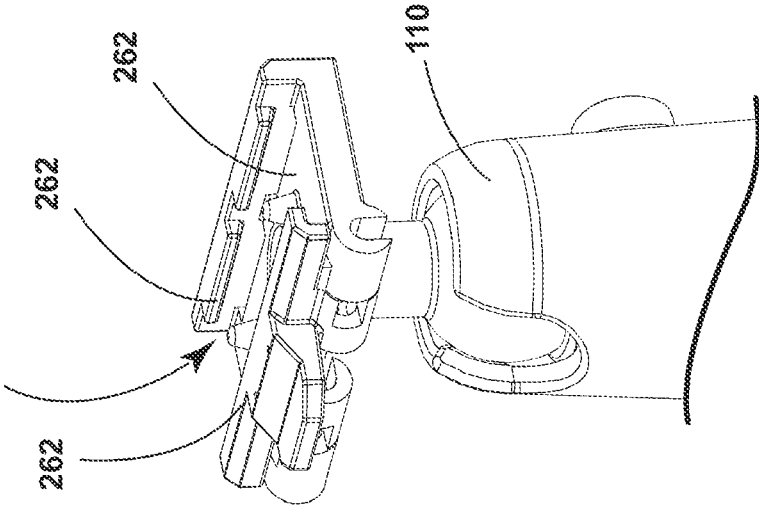

FIG. 20

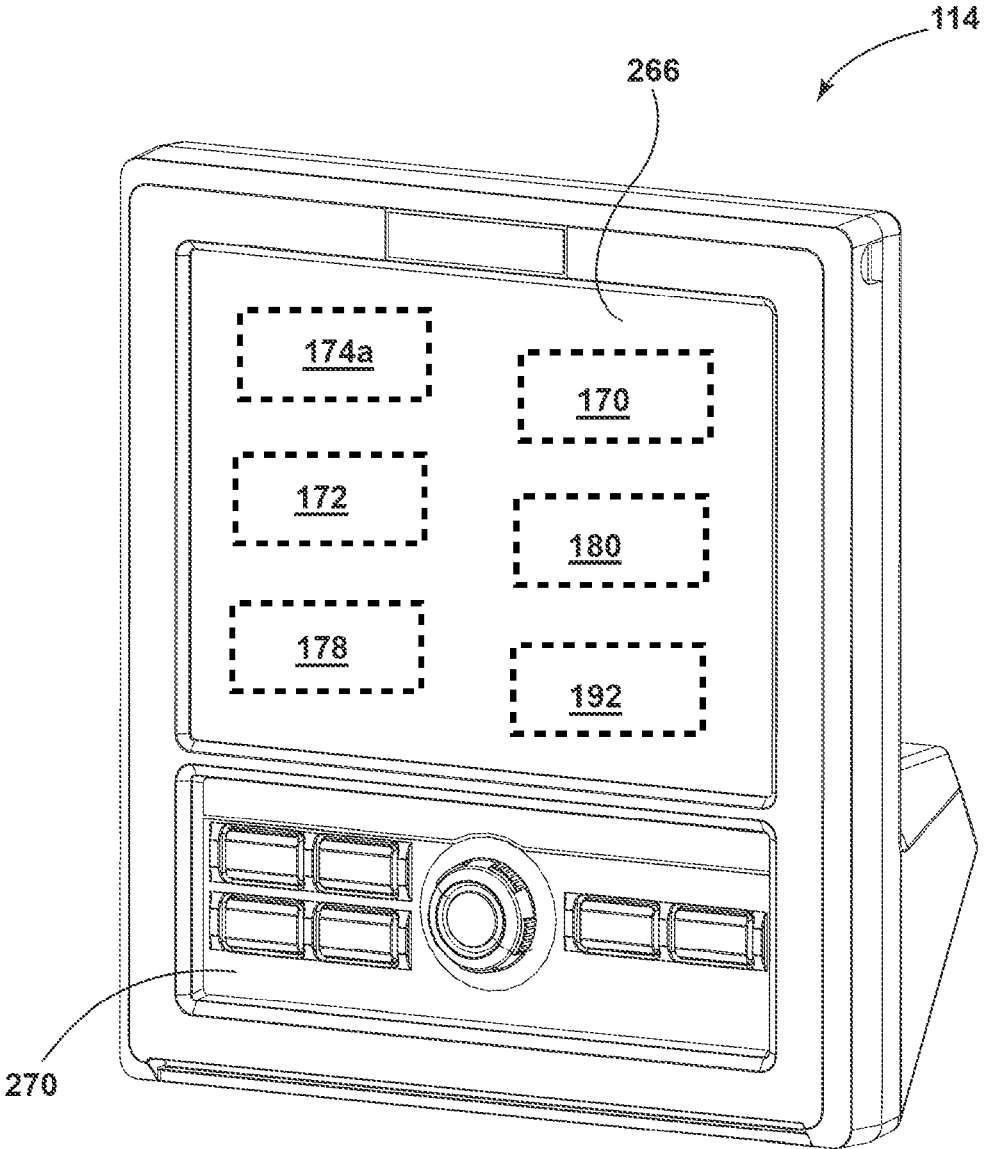

FIG. 21

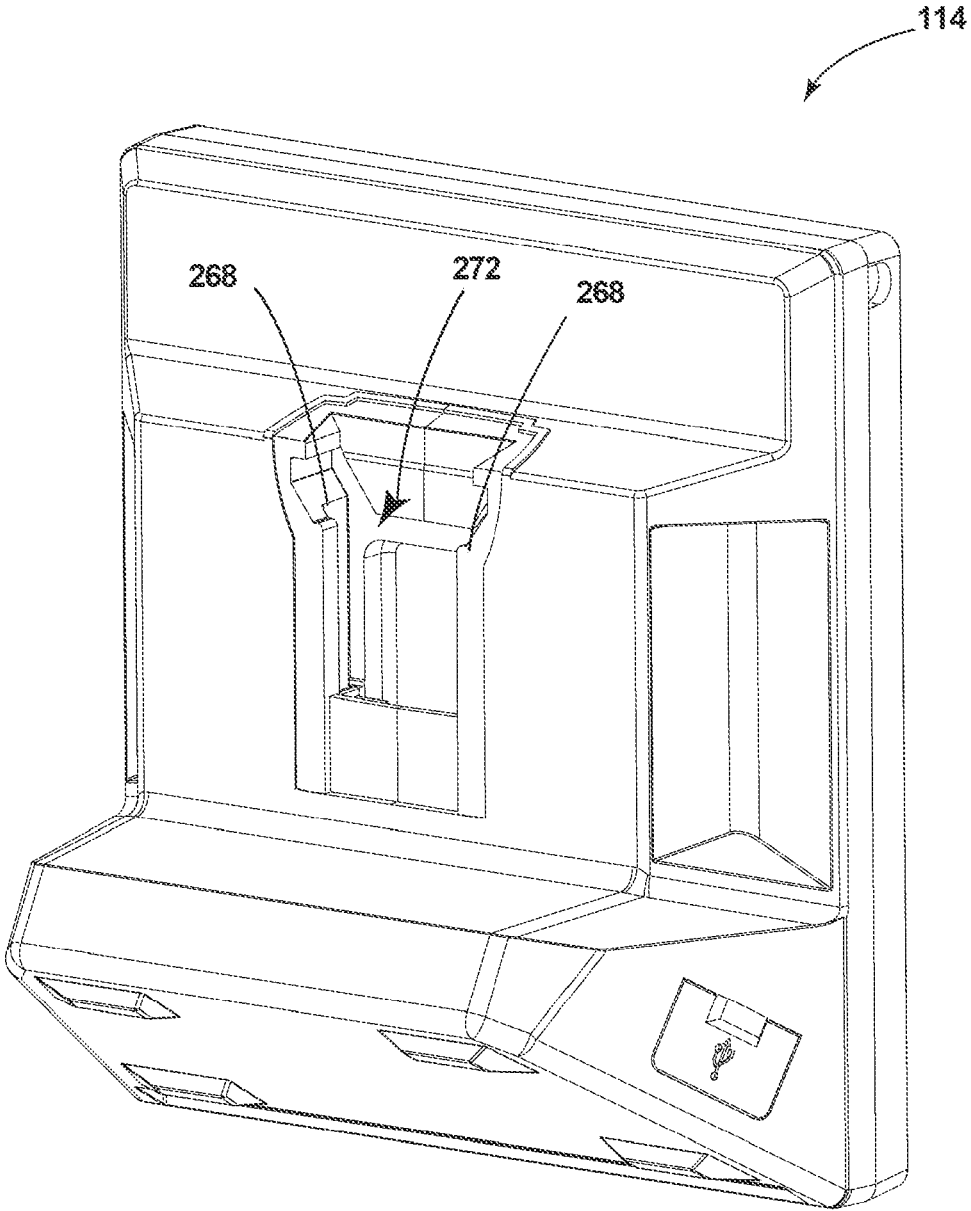

FIG. 22



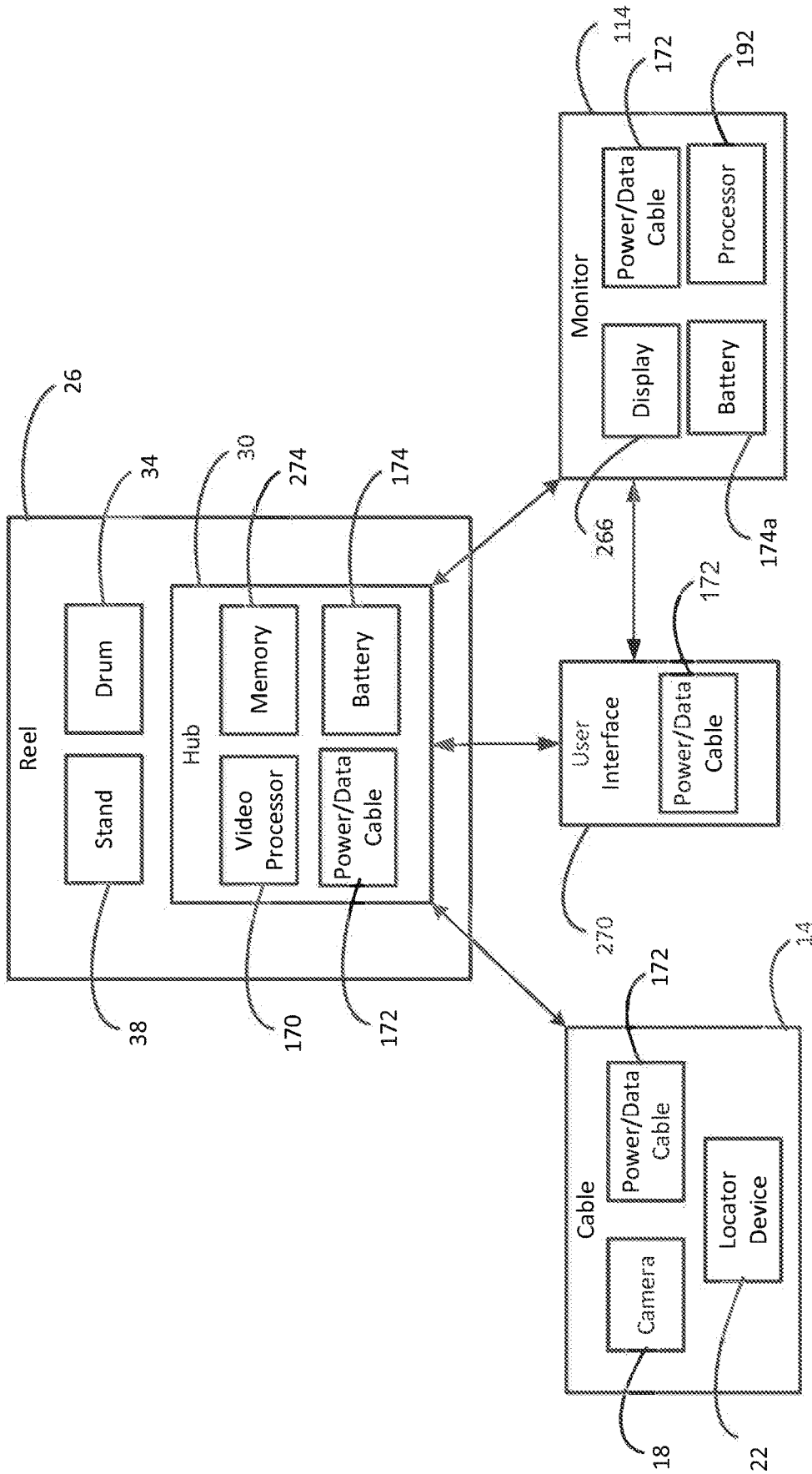

FIG. 23

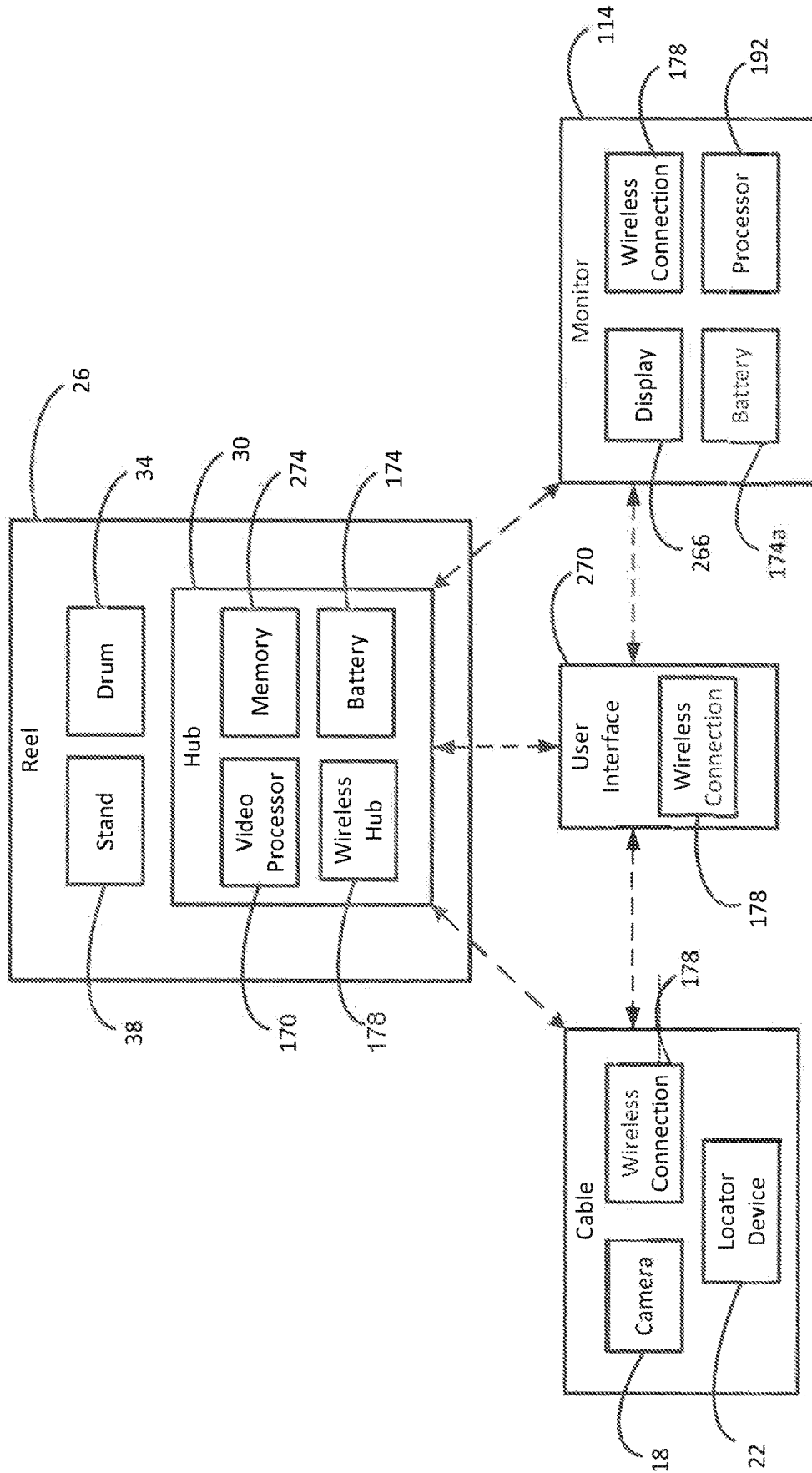

FIG. 24

**PIPELINE INSPECTION DEVICE****CROSS-REFERENCE TO RELATED APPLICATIONS**

The present application is a continuation of U.S. patent application Ser. No. 17/387,313, filed Jul. 28, 2021, now U.S. Pat. No. 11,623,254, which is a continuation of U.S. patent application Ser. No. 16/591,342, filed on Oct. 2, 2019, now U.S. Pat. No. 11,110,495, which is a continuation of U.S. patent application Ser. No. 15/844,270, filed on Dec. 15, 2017, now U.S. Pat. No. 10,434,547, which claims priority to U.S. Provisional Patent Application No. 62/434,786, filed Dec. 15, 2016, and U.S. Provisional Patent Application No. 62/447,102, filed Jan. 17, 2017, the entire contents of each which are incorporated by reference herein.

**FIELD OF INVENTION**

The present invention relates to sewer inspection devices for inspecting sewers, drains, pipes, or other conduits.

**BACKGROUND**

Pipeline inspection devices can be used to determine the location of obstructions in underground pipes or find damaged areas that affect the integrity of pipe systems. Generally, a pipeline inspection device includes a cable that can be pushed down a length of the pipe. The end of the cable may include an imaging device, such as a video camera, to help identify an obstruction or damage within the pipe. The end of the cable may also include a location device, such as a sonde, to transmit the location of the end of the cable. The location device allows a user to find the end of the cable and dig down towards the pipe at the proper location where the obstruction might be.

**SUMMARY**

In one embodiment, the invention provides a pipeline inspection system including a first drum including a first cable having a first camera disposed on a distal end of the first cable, where the first cable is received within an interior of the first drum and is configured to be directed into a conduit, a second drum including a second cable having a second camera disposed on a distal end of the second cable, where the second cable is received within an interior of the second drum and is configured to be directed into a conduit, and a hub housing electrical components for operation of the pipeline inspection system, where the hub is removably received in the interior of the first drum, and where the hub is selectively removable from the first drum and insertable into an interior of the second drum.

In another embodiment, the invention provides a hub for use with a pipeline inspection device. The hub includes a housing sized and shaped to be removably supported by a first drum, where the first drum houses a first cable having a first camera disposed on a distal end of the first cable. The hub is selectively removable from the first drum and removably supported by a second drum, where the second drum houses a second cable having a second camera disposed on a distal end of the second cable. A mating member is configured to removably couple the hub to the first drum and is configured to removably couple the hub to the second drum. The hub further includes a power source supported by the housing, a processor positioned within the housing and configured to be in communication with the first camera

while the hub is coupled to the first drum and in communication with the second camera while the hub is coupled to the second drum, and a memory positioned within the housing and coupled to the processor, where the memory operable to at least temporarily store images captured from the first camera and the second camera.

In yet another embodiment, the invention provides a pipeline inspection system including a first drum including a rear wall, a front wall, and a side wall defining an interior, where the front wall has an opening providing access to the interior. A first cable is received within the interior of the first drum and configured to be directed into a conduit. A first camera is disposed on a distal end of the first cable. The pipeline inspection system further includes hub having a power source, a processor, a memory, and a housing. The housing is defined by a front end, a rear end, and an outer wall extending around a perimeter of the hub between the front end and the rear end. The power source, the processor, and the memory are disposed within the housing. The hub is removably received in the interior of the first drum, and the hub is selectively removable from the first drum and insertable into an interior of a second drum.

Other aspects of the invention will become apparent by consideration of the detailed description and accompanying drawings.

**BRIEF DESCRIPTION OF THE DRAWINGS**

FIG. 1 is a front perspective view of a reel for use in a pipeline inspection device according to a first embodiment.

FIG. 2 is a rear perspective view of the reel illustrated in FIG. 1.

FIG. 3 is a top perspective view of the reel illustrated in FIG. 1.

FIG. 4 is a side view of the reel illustrated in FIG. 1.

FIG. 5 illustrates the reel of FIG. 1 with a drum removed.

FIG. 6 illustrates a mounting assembly for use with the reel of FIG. 1.

FIG. 7 is a cross-sectional view of the reel illustrated in FIG. 1 taken along section line 7-7 shown in FIG. 3.

FIG. 8 is a front perspective view of a hub for use with a pipeline inspection device.

FIG. 9 is a rear perspective view of the hub illustrated in FIG. 8.

FIG. 10 is a first side view of the hub illustrated in FIG. 8.

FIG. 11 is a second side view of the hub illustrated in FIG. 8.

FIG. 12 is a top view of the hub illustrated in FIG. 8.

FIG. 13 is a front perspective view of a reel for use in a pipeline inspection device according to a second embodiment.

FIG. 14 is a rear perspective view of the reel illustrated in FIG. 13.

FIG. 15 is a top perspective view of the reel illustrated in FIG. 13.

FIG. 16 is a side view of the reel illustrated in FIG. 13.

FIG. 17 illustrates the reel of FIG. 13 with a drum removed.

FIG. 18 is a cross-sectional view of the reel illustrated in FIG. 13 taken along section line 18-18 shown in FIG. 15.

FIG. 19 is a detailed view of a ball mount.

FIG. 20 is a detailed view of a locking pin 250.

FIG. 21 is a front perspective view of a monitor for use with a pipeline inspection device.

FIG. 22 is a rear perspective view of the monitor illustrated in FIG. 21.

3

FIG. 23 is a schematic diagram of a pipeline inspection device according to one embodiment.

FIG. 24 is a schematic diagram of a pipeline inspection device according to another embodiment.

Before any embodiments of the invention are explained in detail, it is to be understood that the invention is not limited in its application to the details of construction and the arrangement of components set forth in the following description or illustrated in the following drawings. The invention is capable of other embodiments and of being practiced or of being carried out in various ways. Also, it is to be understood that the phraseology and terminology used herein is for the purpose of description and should not be regarded as limiting. The use of "including," "comprising," or "having" and variations thereof herein is meant to encompass the items listed thereafter and equivalents thereof as well as additional items. Unless specified or limited otherwise, the terms "mounted," "connected," "supported," and "coupled" and variations thereof are used broadly and encompass both direct and indirect mountings, connections, supports, and couplings. Further, "connected" and "coupled" are not restricted to physical or mechanical connections or couplings.

#### DETAILED DESCRIPTION

The invention disclosed herein provides a pipeline inspection device 10, as shown in FIGS. 23 and 24, that can be used to view the interior of the pipe, conduit, etc., such as a buried sewer pipeline to locate obstructions, blockages, and defects in the pipe. Specifically, a user can use the pipeline inspection device 10 to observe the interior of a pipe, often from a distance away from the closest access port to the sewer pipeline. To view the interior of the pipe, a cable 14 is directed down an access port of the pipe and through the sewer pipeline. The cable 14 includes an image capturing device (e.g., a camera 18) and/or a locator device 22 (e.g., a sonde) connected at a distal end thereof, for viewing the interior 54 of the pipeline.

The pipeline inspection device 10 includes a reel 26 (FIGS. 1-4) for housing the cable 14 and a hub 30 (FIGS. 8-12) for housing a power source and other electronic components for operating the pipeline inspection device 10. The cable 14 is stored on the reel 26 in a wound configuration, but can be unwound and threaded through a length of a pipe under inspection. The hub 30 provides power to the components of the reel 26 in order to operate the pipeline inspection device 10. As discussed in greater detail below, the hub 30 is removably coupled to the reel 26. In some embodiments, the hub 30 can be interchangeably used with two or more different reels 26.

FIGS. 1-7 illustrate one embodiment of a reel 26. The reel 26 includes a drum 34 for housing the cable 14 and a stand 38 for supporting the drum 34. The drum 34 includes a closed end defined by a back wall 42, and an open end defined by a front wall 46. A side wall 50 extends around the perimeter of the drum 34 between the front wall 46 and the back wall 42. Together, the back wall 42, the side wall 50, and front wall 46 define an interior 54 of the drum 34 that houses the cable 14. The front wall 46 includes an opening 58 that provides access to the interior 54 of the drum 34. As will be discussed in further detail below, the hub 30 (FIGS. 8-12) can be inserted into the drum 34 via the opening 58.

The drum 34 rotates about an axis extending through the back wall 42 and the opening 58 of the front wall 46. The cable 14 is stored within the interior 54 and is wound about the axis of the drum 34. The drum 34 can be different sizes

4

in order to accommodate different size or lengths of cables 14. Because the cable 14 is stiff (e.g., a push cable 14), the cable 14 exerts an outward force towards the walls of the drum 34, and particularly, towards the side wall 50. Thus, the cable 14 frictionally engages the walls of the drum 34 such that the cable 14 rotates about the axis of the drum 34 as the drum 34 rotates. Rotation of the drum 34 in a first direction causes the cable 14 to unwind so that the cable 14 can be extended into the pipe. In some embodiments, the drum 34 can also be rotated in a second direction to retract the cable 14 from the pipe and wind cable 14 back into the drum 34. In some embodiments, the drum 34 includes ribs on the inside of the drum 34 to provide for increased frictional engagement with the cable 14.

The drum 34 is supported above the ground by the stand 38. The stand 38 includes a base 66 and a center support 70 extending upward from the base 66. In the embodiment illustrated in FIGS. 1-7, the base 66 includes a platform 74, two front feet 78 and two back wheels 82. To transport the reel 26, the center support 70 can be tilted backwards so that the front feet 78 are lifted off of the ground and the wheels 82 can be used to transport the reel 26. When in operation, the front feet 78 engage the ground to inhibit the reel 26 from moving. The wheels 82 are each connected to the platform 74 by an independent axle 86. In other words, in the illustrated embodiment, the wheels 82 are not connected to one another by a single axle 86 extending between both wheels 82. Rather, each wheel 82 is rotatably coupled to the platform 74 by a separate axle 86 that is capable of independent rotation.

The center support 70 includes one or more handles to help maneuver and operate the pipeline inspection device 10. In the illustrated embodiment, the center support 70 includes a first handle assembly 90, including a telescoping handle 94 that retracts into a hollow portion of the center support 70. The telescoping handle 94 can be adjusted between an extended position, for example during transportation, and a retracted position, for example during operation or while stored. When in the extended position, the telescoping handle 94 enables a user to transport the reel 26 in a similar way as a carry-on suitcase. When in the retracted position, the telescoping handle 94 is compactly stored within the center support 70. In the illustrated embodiment, the center support 70 is formed as an extruded aluminum frame 106. This provides for a lightweight material that can receive the handle when in the retracted position. However, in other embodiments, the center support 70 can be formed of steel tubing or other materials.

In the illustrated embodiment, the center support 70 also includes a second handle assembly 98 having two handle bars 102 extending outwardly from the center support 70. The second handle assembly 98 includes a frame 106 that supports the handle bars 102 above the drum 34. The second handle assembly 98 extends in a forward direction above the drum 34, with the handle bars 102 extending outwardly, towards respective wheels 82. Accordingly, the center support 70 includes the first handle assembly 90, which extends in a vertical direction (when oriented as shown in FIG. 2), and a second handle assembly 98, which extends in a horizontal direction (when oriented as shown in FIG. 2). However, in other embodiments, the second handle assembly 98 may be oriented in a different direction. For example, in some embodiment, the second handle assembly 98 may extend backwards, away from the drum 34.

The center support 70 also includes a mount 110 on the second handle assembly 98. The mount 110 can be used to support a monitor 114 (see, FIGS. 20-21), or other compo-

ment of the pipeline assembly device. The mount 110 is supported on the frame 106 of the second handle assembly 98 in a position between the handle bars 102. In the illustrated embodiment, the mount 110 is a ball mount 110. The ball mount 110 creates a rotatable connection that allows the monitor 114 to be rotated in multiple directions. For example, the ball mount 110 allows for rotation in a swivel direction (e.g., left and right) and a tilt direction (i.e., up and down).

With references to FIGS. 5-7, the drum 34 is supported on the stand 38 by a mounting assembly 118. The mounting assembly 118 includes a rotatable portion and a fixed portion. The drum 34 is mounted on the rotatable portion of the mounting assembly 118, while the hub 30 is mounted to the reel 26 via the fixed portion of the mounting assembly 118. The mounting assembly 118 includes a mounting plate 122, a shaft 126, a slip ring 130, a disk 134, and a core 138. The mounting plate 122, (a portion of) the slip ring 130, and the disk 134 are rotatably fixed relative to one another, and thus, rotate together with the drum 34. Thus, the rotatable portion of the mounting assembly 118 includes the mounting plate 122, the slip ring 130, and the disk 134. In other words, the drum 34, the mounting plate 122, the slip ring 130, and the disk 134 rotate together relative to the stand 38. The shaft 126 and the core 138, on the other hand are rotatably fixed relative to one another and relative to the stand 38. The fixed portion of the mounting assembly 118 includes the shaft 126 and the core 138.

The shaft 126 is coupled to the center support 70 of the stand 38. The shaft 126 provides a cantilevered support for the drum 34 above the platform 74 of the stand 38. Specifically, the shaft 126 engages and supports the drum 34 only via the back wall 42. Because the drum 34 includes the opening 58 in the front wall 46, the shaft 126 does not extend through the entire width of the drum 34 or engage the front wall 46. This creates a cantilever effect whereby the drum 34 is cantilevered over the platform 74 by the engagement of the shaft 126 with the back wall 42 of the drum 34. This cantilevered design enables the front wall 46 of the drum 34 to include the opening 58 for inserting the hub 30 into the interior 54 of the drum 34.

The mounting plate 122 is fixed to the back wall 42 of the drum 34. In some embodiments, the mounting plate 122 is integral with the back wall 42 of the drum 34. The slip ring 130 is disposed within a space 142 (FIG. 7) formed by the back wall 42 of the drum 34. The slip ring 130 allows for transmission of electrical signals, while allowing the drum 34 to rotate relative to the reel 26. The mounting plate 122 and the slip ring 130 rotatably support the drum 34 on the shaft 126. Specifically, the shaft 126 extends at least partially through the mounting plate 122 and the slip ring 130, which allow the drum 34 to rotate about the shaft 126.

The disk 134 also rotates with the drum 34. The disk 134 includes magnets 146 that rotate with the disk 134 and the drum 34 as the cable 14 is unwound from the drum 34. The magnets 146 are used in conjunction with a sensor 150 (FIG. 6) on the hub 30 to measure how much cable 14 has been unwound. Specifically, as the drum 34 rotates, the magnets 146 rotate about the axis of the drum 34. The sensor 150 (e.g., a Hall sensor) is located on the stationary hub 30 along the axis. As the magnets 146 rotate, the sensor 150 can monitor 114 the movement of the magnets 146 to determine how much cable 14 has been extended from the drum 34.

The core 138 is coupled to a distal end of the shaft 126. The core 138 does not rotate with the drum 34, but rather, is fixed relative to the shaft 126 and the stand 38. The core 138 supports the hub 30 when the hub 30 is inserted into the

interior 54 of the drum 34 via the opening 58 on the front wall 46. The core 138 includes an engagement surface 154 that enables the hub 30 to be removably coupled to the reel 26. The core 138 also includes electrical connections that engage with electrical connections on the hub 30. In addition, the core 138 includes at least one recess 158 that aligns and engages with a portion of the hub 30. The recesses 158 help secure the hub 30 to the reel 26 and maintain a slide electrical connection between the two.

In the illustrated embodiment, the core 138 has a circular face 162 with an annular lip 166 extending around the perimeter of the face 162. The engagement surface 154 is formed along the lip 166 on a top side of the core 138. Specifically, the engagement surface 154 is formed by a flattened portion of the annular lip 166. The hub 30 can grip the core 138 along the flattened portion of the lip 166. In other embodiments, the core 138 can be different shapes that are suitable to provide an engagement surface 154 for coupling to the hub 30.

Referring to FIG. 23, the hub 30 includes a power source and other electrical components for operating the pipeline inspection device 10. For example, the hub 30 may include a video processor 170, a battery 174, a wireless communication module 178 (e.g., a Wi-Fi hub, a Bluetooth module), etc. In other embodiments, the hub 30 may include more or fewer of these electrical components. For examples, in some embodiments, the hub 30 does not include a wireless communication module 178, but rather, includes wired connections to the monitor 114 and other components. Similarly, in some embodiments, the hub 30 does not include a video processor 170. Instead, the video processor 170 may be integrated into the monitor 114.

Referring to FIGS. 8-12, the hub 30 includes a cylindrical body 182 that is received within the interior 54 of the drum 34. The cylindrical body 182 is defined by a front end 186, a rear end 190, and an outer wall 194 extending around the perimeter of the hub 30 between the front end 186 and the rear end 190. The rear end 190 of the hub 30 has a cavity 198 that includes various mating members that engage with the core 138 of the reel 26. The mating members secure the hub 30 to the reel 26 and help align the hub 30 and maintain a solid connection between the hub 30 and the reel 26. These mating members will be described in greater detail below.

The cylindrical body 182 defines a housing for maintaining the electrical components of the pipeline inspection device 10. In some embodiments, the body 182 is air and/or water tight in order to protect the electrical components. In the illustrated embodiment, the front end 186 of the hub 30 includes a battery housing 202 for receiving a battery 174. The battery 174 is removable from the battery housing 202 of the hub 30. The battery housing 202 includes a cover 206 that can be opened and closed to insert and remove the battery 174, respectively. The cover 206 forms an air and/or water tight seal to protect the battery 174 and other electrical components. The cover 206 is attached to the front end 186 by a hinge 210 and a latch 212. The hub 30 also includes a channel 218 extending through the cylindrical body 182 from the outer wall 194 to the front end 186. When the hub 30 is inserted in the drum 34, the channel 218 receives the cable 14 and helps guide the cable 14 into or out of the drum 34. In addition, the hub 30 may include a holding mechanism configured to hold the camera 18 during storage such that the cable 14 is prevented from spooling out and the camera 18 is prevented from falling into the hub 30.

In addition, the hub 30 includes a handle 222 provided on the front end 186 of the hub 30. The handle 222 extends outwardly from the front end 186 of the hub 30 and can be

used to maneuver the hub 30 into the opening 58 of the drum 34. The handle 222 includes a trigger 226 (FIG. 12) that activates a latch 214 on the rear end 190 of the cylindrical body 182. The latch 214 is one of the mating members disposed within the cavity 198 of the hub 30. The latch 214 is configured to engage with the engagement surface 154 on the core 138 of the mounting assembly 118 of the reel 26. Pressing the trigger 226 rotates the latch 214 from a locked position to an unlocked position. In the illustrated embodiment, pressing the trigger 226 rotates the latch 214 upward into the unlocked position. The latch 214 is biased towards the locked position such that releasing the trigger 226 causes the latch 214 to rotate downward and into the locked position.

The hub 30 also includes various other matting members that help align and support the hub 30 within the drum 34. The cavity 198 of the hub 30 includes at least one protrusion 230 that is shaped to align with the recesses 158 on the core 138 of the mounting assembly 118. For example, the hub 30 includes a square protrusion 230 that is received within the square recess 158 on the face 162 of the core 138. The protrusion 230 defines a pocket that receives the sensor 150 for monitoring movement of the magnets 146 to help determine the amount 110 of cable 14 that has been extended from the drum 34. In some embodiments, the core 138 and the hub 30 may include more or fewer recesses 158 and protrusions 230, respectively, to help align the hub 30 with the drum 34. In the illustrated embodiment, the hub 30 also includes a rim 234 that extends around the perimeter of the cylindrical body 182 for mating with the opening 58 of the drum 34. When the hub 30 is received within the drum 34, the rim 234 engages with the edge of the opening 58 to help align the hub 30 relative to the drum 34. In the illustrated embodiment, the rim 234 further includes a hook 238 to help grip the edge of the opening 58 in the drum 34. In the illustrated embodiment, the hook 238 is arcuate and extends along a bottom edge of the rim 234.

As previously mentioned, the hub 30 is removable from the drum 34 and may be attached to two different sized reels 26. Pipes typically come in two different sizes: a 1.5 to 3 inch diameter pipe and a 3 to 6 inch diameter pipe. Each of the two types of pipes requires a different diameter camera and cable. The smaller pipe (i.e., 1.5 to 3 inch pipe) requires a smaller diameter camera and cable that is more flexible, while the larger pipe requires a larger diameter camera and cable. Each of the smaller diameter camera and cable and the larger diameter camera and cable requires a correspondingly sized reel and cable drum, which are part of correspondingly sized pipeline inspection devices. In the illustrated embodiment, the hub 30 may be removably detached and interchangeably attached to each of the drums of the different sized pipeline inspection devices, such that a user only needs a single hub 30 containing the electronics (e.g., the video processor 170, the battery 174, the wireless communication module 178 (Wi-Fi hub), etc.) that can be used with either of the reels 26.

FIGS. 13-18 provide another embodiment of a reel 26a that can be used with the hub 30. The reel 26a illustrated in FIGS. 13-18 is smaller than the reel 26 illustrated in FIGS. 1-6. In the embodiment illustrated in FIGS. 13-18, the reel 26a is a more compact size to improve transportability. For example, in the illustrated embodiment, the reel 26a can be carried as a backpack. The reel 26a includes a drum 34a supported by a stand 38a. The drum 34a includes an open front wall 46a defining an opening 58a for receiving the hub 30 and a closed back wall 42a for mounting to the stand 38a. The stand 38a includes a platform 74a and a center support

70a extending upwardly from the platform 74a. A backpack plate 242 is removably coupled to the center support 70a. The backpack plate 242 can include backpack straps that enable a user to carry the reel 26a on his/her back. If desired, the backpack portion of the reel 26a (i.e., the backpack plate 242 and straps) can be removed from the reel 26a.

The backpack plate 242 is removably coupled to the stand 38a by a slot and locking pin 250 (FIG. 20). The top portion of the backpack plate 242 includes a slot 236 for receiving a hook 238 disposed on center support 70a. The bottom portion of the backpack plate 242 includes the locking pin 250. The locking pin 250 includes pin holes in the backpack plate 242 and the center support 70a, and a pin that extends through both holes. To remove the backpack plate 242, the pin is removed from the holes to release the backpack plate 242.

The reel 26a is configured to be operated in either a vertical orientation or a horizontal orientation. The stand 38a includes feet 78a along a bottom surface of the platform 74a for supporting the reel 26a in an upright (i.e., vertical) position, as shown in FIG. 13. The stand 38a can also be oriented in a horizontal position by laying the reel 26a on the center support 70a with the backpack plate 242 removed. The stand 38a includes a first surface 254 along a bottom of the stand 38a and a second surface 258 along the top of the stand 38a that can support the reel 26a in a horizontal orientation. Specifically, the first surface 254 extends along a back edge of the platform 74a, and the second surface 258 extends along a back edge of the center support 70a. Together, the first surface 254 and the second surface 258 form a second set of feet 78a for supporting the reel 26a in a horizontal orientation.

In addition, the reel 26a includes a handle assembly supported by the center support 70a. Specifically, the center support 70a includes a handle assembly having two handle bars 102a extending in outwardly from the center support 70a. The handle assembly includes a frame 106a that supports the handle bars 102a above the drum 34a. The handle assembly extends in a forward direction above the drum 34a, with the handle bars 102a extending outwardly.

The center support 70a also includes a mount 110a on the handle assembly. The mount 110a can be used to support the monitor 114 (see, FIGS. 21-22), or other component of the pipeline assembly device. The mount 110a is supported on the frame 106a of the handle assembly in a position between the handle bars 102a. In the illustrated embodiment, the mount 110a is a ball mount 110a that is capable of rotating in two directions. For example, the ball mount 110a allows for rotation in a swivel direction (e.g., left and right) and a tilt direction (i.e., up and down). In this embodiment, that ball mount 110a includes a clip 262, shown in FIG. 19, which allows for a quick attachment/detachment of the monitor 114a or other component. For example, the clip 262 can include a snap fit connection, a slide connection, a detent connection, or the like. The clip 262 includes a set of rails 260 that form a channel 264. This allows components, such as the monitor 114, to be slidably received within the channel 264.

FIGS. 21-22 provide an embodiment of the monitor 114, which can be used with the reels 26, 26a illustrated herein. The monitor 114 is configured to engage with the clip 262 on the mount 110a. Specifically, the monitor 114 includes a set of rails 268 that form a channel 272. The rails 268 and the channel 272 of the monitor 114 are configured to slidably engage with the rails 260 and the channel 264 on the clip 262 portion of the mount 110a. Thus, the monitor 114 can be slide onto the clip 262 to be supported on the reel 26a. The

monitor **114** includes a display device **266** for viewing an image or video captured by the camera **18**, and a user interface **270** for controlling the camera **18** and/or the display device **266**. In some embodiments, the user interface **270** may be a separate device from the display device **266**. For example, the user interface **270** may be on a user mobile device, such as through an application on a phone. This may allow a user to control the operation of the pipeline inspection device **10** through the application on the phone.

In some embodiments, the display device **266** and the camera **18** are capable of providing high definition images. Furthermore, in some embodiments, the monitor **114** includes a WiFi hub (i.e., a wireless communication module **178**) to allow for wireless communication between the monitor **114** and the hub **30**. This allows for the monitor **114** to be removed from the reel **26** while continuing to have a functioning display device **266** showing images captured by the camera **18**. In other embodiments, the display **114** may include power and data cables **172** in place of, or in addition to the wireless communication module **178**. The monitor **114** may also include a memory storage device **180** or may interface with removable memory storage devices to store the image(s) or video(s) captured by the camera **18**.

The user interface **270** includes a control panel (e.g., buttons, touch screen, or rotatable dial) for controlling the operation of one or both of the camera **18** and the display device **266**. The user interface **270** may also be used to control the operation of the camera **18**. For example, the user interface **270** may enable a user to control lights, take a picture, or start and stop the recording feature of the camera **18**. Similarly, the user interface **270** may be used to navigate through the software programs on the display device **266**. For example, the user may be able to stop or restart the distance counter that tracks the end of the cable **14** as it extends through the pipe, adjust the brightness of the display device **266**, or rearrange the items showing on the display device **266**.

Additionally, in some embodiments, the user interface **270** enables a user to “flag” certain troublesome areas of the pipe, or make notes about the condition of the pipe as the camera **18** is pushed through the pipe. For example, in some embodiments, the user interface **270** includes a keyboard and/or a microphone, which allows a user to make notes on what the camera **18** is displaying via the display device **266**. A user may be able to use the microphone to make “voiceover” comments on the video. Similarly, the keyboard may enable the user to type in comments that pop up on the video images.

Furthermore, in some embodiments, a processor **192** (i.e., software program) on the monitor **114** may be capable of manipulating the video recorded by the camera **18**. For example, the software program can create a compressed highlight reel **26** showing only the portions of the video (or the pictures) that were flagged by a user or include a comment (i.e., voiceover comment or typed comment). The highlight reel **26** skips over the portions of the video or the picture that are not deemed relevant by the user or may not need attention, and instead, compresses the video into a shorter video that only shows the more relevant areas of the pipe under inspection.

The videos can often be long or include lengthy portions of video clips that are not of interest to a user. In addition, while high definition images and video offer some advantages, such as the clarity of image and ability to zoom in on a point of interest, high definition video increases the file size of the videos and requires more storage space on the memory **274**. Therefore, in some embodiments, the software

program creates a shorter video showing only the points of interest. As a pipe inspection is taking place, points of interest or “highlights” are documented with captured images (which are also stored), text labels and audio clips.

After the original video is created, a second video, the “highlights reel”, can be created either with input from the user or automatically. The video is reduced in file size and length by removing the portions of the video that are less important to the viewer. In some embodiments, a user may set a minimum or a maximum file size or footage length for the highlights reel. For example, a user may set the maximum file size to a size that can be emailed. The software program can determine how many seconds of each point of interest to show in order to keep the highlight reel within a certain file size or length. Furthermore, in some embodiments, the software program includes some of the video frames between each highlight in order to show continuity of the video. The software program could decide how often to insert a frame of video between each highlight while still remaining within the designated file size. At any point during the highlight reel, the user can pause the video and inspect the frame as well as zoom in to take a closer look at the pipe. The user can then continue watching the video when desired. In some embodiments, the portion of the video that is not used for the highlights reel is discarded.

In the illustrated embodiment, the monitor **114** includes a second battery **174a** that is separate from the battery **174** housed in the hub **30**. In some embodiments, the pipeline inspection device **10** includes a bi-directional power transfer between the battery **174a** on the monitor **114** and the battery **174** on the hub **30**, such that the battery **174** in the hub **30** and the battery **174a** in the monitor **114** can be used interchangeably. In other words, when the battery **174** in the hub **30** runs out of power, the battery **174a** in the monitor **114** can be used as a back up to power both the monitor **114** and the drum **34**. Likewise, when the battery **174a** in the monitor **114** runs out of power, the battery **174** in the hub **30** can be used to power both the monitor **114** and the drum **34**. In some embodiments, a USB-C cord can be used to charge can be used to connect either the monitor **114** or the hub **30** to the opposite battery **174**, **174a**. In some embodiments, one of the batteries **174** can be charged through the other battery **174** using a USB-C cord, a cable, or through inductive flow, and visa versa. The charging can be continued until the batteries **174** have equal power and can thus remain powered for the same amount of time.

The electrical and mechanical components of the pipeline inspection device **10** can be arranged in different manners, some including wired connections and some wireless connections. Example embodiments of a wired connection and a wireless connection are provided below. However, in other embodiments, some components communicate wirelessly while others include a direct wired connection.

As shown in FIG. **23**, in one embodiment, in order to power the camera **18** and deliver a signal from the camera **18** to a display device **266**, power and data cables **172** are connected to the camera **18** and accompany the cable **14** down the sewer. The power and data cables **172** may freely extend side-by-side with the cable **14** or be contained within an outer sheath by or with the cable **14**. The battery **174** and video processor **170** are fixedly attached to the hub **30** so as to be rotationally stationary relative to the stand **38**. The power and data cables **172** are electrically connected to the hub **30** (e.g., the battery **174** and the video processor **170** hub **30**) to provide power to the camera **18** and provide a data signal from the camera **18** to the video processor **170**, respectively. However, in order to maintain an electrical

connection between the camera **18**, the video processor **170**, and the battery **174**, without twisting the wire connection therebetween, the power and data cables **172** are electrically connected to the battery **174** and the hub **30** by the slip ring **130** connection. The slip ring **130** connection allows for transmission of electrical signals from the power and data cables **172** to the battery **174** and other electrical components in the hub **30**, while allowing the drum **34** to rotate relative to the reel **26**. In the illustrated embodiment, the monitor **114** is powered by a separate battery from the battery **174** in the hub **30**. However, in some embodiments, the monitor **114** is connected by a wired connection to the battery **174** in the hub **30**. Also, as previously mentioned, the battery **174** in the hub **30** and the battery in the monitor **114** may be used to power one or both of the hub **30** and the monitor **114** when the opposite battery **174** is out of power. The batteries **174** may each be rechargeable and may be configured to be interchangeably used with other battery **174** powered devices (e.g., power tools).

As shown in FIG. **24**, in other embodiments, the battery **174** and the video processor **170** are fixedly attached to the hub **30** and communicate wirelessly to the camera **18** and the monitor **114**. For example, in one embodiment, the hub **30**, including the video processor **170** and the battery **174**, is fixedly attached to the drum **34**, and thus rotates with the drum **34** as the cable **14** is spooled and unspooled. This eliminates the need for the slip ring **130**. In addition, the wired connection between the hub **30** and the monitor **114** can be replaced with a wireless connection (e.g., Wi-Fi, Bluetooth, etc.) between the video processor **170** and the monitor **114**. The hub **30** may contain a wireless communication module **178** for establishing the wireless connection to wirelessly communicate with the monitor **114** and the user interface **270** (if the user interface **270** is a separate unit). The user interface **270** for controlling functions of the camera **18** may be built into the monitor **114**, or may communicate wirelessly to the monitor **114** and/or the camera **18**. For example, the user interface **270** may be a Wi-Fi enabled smart device that has a software application including a user interface for controlling the camera **18**.

In operation, the camera **18** and the cable **14** are fed into the sewer pipeline via the access port by a user. The camera **18** is snaked from the access port through the sewer to the point of interest (e.g., obstruction, blockage, etc.) while the camera **18** sends data signals to the video processor **170** in the hub **30** that are then processed and sent to the monitor **114** to be viewed on the display device **266** by the user.

When the camera **18** reaches the area of interest, the user may physically locate the camera **18** at that location from above ground so that, for example, the user may dig at that spot to access that portion of the sewer pipeline. Accordingly, in some embodiments, the pipeline inspection device **10** includes a locator device **22** to help locate the end of the cable **14** at the location of the camera **18**. Alternatively, the camera **18** may include a signal generating module (e.g., a sonde) that emits a point source electromagnetic field (i.e., EM field) which can be detected with a locating device by the user above ground. The module may include an oscillator, transmitter, and antenna within the camera **18**. The locator receives the resulting strongest reading of the point source EM field directly above the point source (i.e., the camera **18**). However, due to the field being only emitted as a point source originating from the camera **18**, it may be difficult for a user to locate. The pipeline may be plastic, metallic, or another similar material.

In some embodiments, the pipeline inspection device **10** may include a signal generating device or transmitter having

a first, outgoing electrical cable and a second, return electrical cable. In some embodiments, the transmitter may be a separate device from the pipeline inspection device **10**. The transmitter further includes an oscillator and amplifier to generate an alternating electrical signal through the first electrical cable. The signal is returned through the second electrical cable (ground or return path) resulting in current that generates an EM field around the signal path (i.e., along the first and second cable). The oscillator can generate a multitude of frequencies from below approximately 1 KHz to approximately 100 KHz. The user may select a frequency that overcomes conditions present within the buried pipeline, such as pipe conductivity and length, wet or dry ground conditions, etc.

In some embodiments, the cable **14** may include a circuit consisting of the first and second electrical cables of the transmitter extending along the length of the cable **14**, such that the alternating electrical signal is transmitted along the cable **14**. Accordingly, the alternating signal generates the EM field along the entire path of the cable **14**. The EM field can be detected by the user with a locator along the entire length and path of the cable **14** (regardless of the material from which the sewer pipeline is constructed, e.g., metal, plastic, etc.). Effectively, the first and second electrical cables create an antenna that emits the EM field. The locator detects the resulting EM field directly above ground, giving the user pipe position data (e.g., depth, etc.). Since the EM field is detectable with the locator along the entire length of the cable **14**, the user may easily follow the EM field (i.e., the cable **14**) directly to the location above the camera **18**. The locator includes an antenna and receiver that can obtain vector information of the EM field (i.e., both magnitude (signal strength) and signal direction). With this data the user can determine the location of the source of the EM field.

The embodiments described above and illustrated in the figures are presented by way of example only and are not intended as a limitation upon the concepts and principles of the present invention. As such, it will be appreciated that various changes in the elements and their configuration and arrangement are possible without departing from the spirit and scope of the present invention. Various features and advantages of the invention are set forth in the following claims.

What is claimed is:

1. A hub for use with a pipeline inspection device including a reel and a cable disposed at least partially within the reel, the cable including a camera, the hub comprising:
  - a body configured to be selectively coupled to the reel;
  - a mating member positioned on the body, the mating member configured to removably secure the body to the reel;
  - a wireless communication module positioned within the body, the wireless communication module configured to create a wireless connection between the hub and a remote device including a display;
  - a battery receptacle on the body; and
  - a battery removably coupled to the battery receptacle, the battery configured to provide power to the camera.
2. The hub of claim 1, wherein the body is removable from the reel and selectively connectable to a second reel, the second reel having a second cable and a second camera.
3. The hub of claim 2, wherein the battery is configured to provide power to the second camera when the body is connected to the second reel.
4. The hub of claim 2, wherein the first reel includes a first drum, and wherein the second reel includes a second drum that is different than the first drum.



13

5. The hub of claim 1, wherein the battery provides power to the wireless communication module.

6. The hub of claim 1, further comprising a first electrical connection positioned on the body, wherein the first electrical connection is configured to mate with a second electrical connection on the reel.

7. The hub of claim 1, wherein the body has a cylindrical shape and is configured to be received in an opening on the reel, and wherein the mating member includes a rim extending around at least a portion of the perimeter of the cylindrical body and configured to mate with the opening.

8. A hub for use with a pipeline inspection device including a reel and a cable disposed at least partially within the reel, the cable including a camera, the hub comprising:

a body including a rear end and a front end opposite the rear end, the rear end having a cylindrical shape and being selectively receivable in an opening of the reel;

a mating member positioned on the body, the mating member configured to removably couple the body to the reel;

a wireless communication module positioned within the body, the wireless communication module configured to create a wireless connection between the hub and a remote device including a display; and

a battery receptacle disposed on the front end of the body, the battery receptacle configured to selectively receive a battery that provides power to the camera.

9. The hub of claim 8, further comprising a first electrical connection disposed on the rear end of the body, the first electrical connection configured to mate with a second electrical connection on the reel.

10. The hub of claim 9, further comprising a video processor positioned within the body, the video processor configured to receive data signals from the camera.

11. The hub of claim 8, wherein the reel includes a rotatable drum having an axis of rotation, and wherein hub is received within the opening on the drum along the axis of rotation.

12. The hub of claim 11, wherein the mating member includes a rim extending around at least a portion of the perimeter of the cylindrical body and configured to mate with the opening.

13. The hub of claim 12, wherein the battery receptacle is accessible such that the battery may be attached to and removed from the battery receptacle when the rear end is inserted into the reel.

14. The hub of claim 8, wherein the body is removable from the reel and selectively insertable into a second reel, the second reel having a second cable and a second camera.

14

15. The hub of claim 14, wherein the first reel includes a first drum, and wherein the second reel includes a second drum that is different than the first drum.

16. A hub for use with a first pipeline inspection device and a second pipeline inspection device, the first pipeline inspection device including a first drum, a first cable, and a first camera, the second pipeline inspection device including a second drum, a second cable, and a second camera, the hub comprising:

a body configured to be alternately couplable to and removable from the first pipeline inspection device and the second pipeline inspection device, the second pipeline inspection device having a different configuration than the first pipeline inspection device;

a mating member positioned on the body, the mating member configured to removably couple the body to the first pipeline inspection device and the second pipeline inspection device;

a wireless communication module positioned within the body, the wireless communication module configured to create a wireless connection between the hub and a remote device including a display; and

a battery receptacle on the body, the battery receptacle configured to selectively receive a rechargeable battery that selectively provides power to the first camera and the second camera.

17. The hub of claim 16, wherein the body includes a rear end and a front end opposite the rear end, wherein the rear end is configured to be alternately inserted into a first opening on the first drum and a second opening on the second drum, and wherein the front end includes the battery receptacle.

18. The hub of claim 17, further comprising a first electrical connection disposed on the rear end, wherein the first electrical connection is configured to mate with a second electrical connection on the first pipeline inspection device when the rear end is inserted into the first opening, and wherein the first electrical connection is configured to mate with a third electrical connection on the second pipeline inspection device when the rear end is inserted into the second opening.

19. The hub of claim 16, wherein the wireless communication module is powered by the battery.

20. The hub of claim 16, further comprising a video processor positioned within the body, the video processor configured to receive data signals from the camera.

\* \* \* \* \*