



US 20040132592A1

(19) **United States**

(12) **Patent Application Publication**
Yu

(10) **Pub. No.: US 2004/0132592 A1**

(43) **Pub. Date: Jul. 8, 2004**

(54) **ADJUSTABLE HANDLES FOR SPRING BARS**

(52) **U.S. Cl. 482/126**

(75) **Inventor: Hui-Nan Yu, Taoyuan (TW)**

(57) **ABSTRACT**

Correspondence Address:
YU, HUI-NAN
SEC. 3, Taijunggang Rd.,
Shituen Chiu
Taichung 4F.-8, NO. 123 (TW)

(73) **Assignee: JAO-HSING TSAI**

A spring bar includes a spring and two tubes are respectively connected to two ends of the spring. Each of the tubes has a slot and a plurality of positioning recesses are defined in two insides defining the slot. Two mounting collars are respectively mounted to the two extensions on the two handles and a through hole is defined through each of the mounting collars. Two positioning members each have a spring member which is biased in the mounting collar corresponding thereto and movably extend through the positioning hole and insert in the slot. An annular groove is defined in each of the positioning members so that the handles can be pulled outward after the positioning members are pushed.

(21) **Appl. No.: 10/337,345**

(22) **Filed: Jan. 7, 2003**

Publication Classification

(51) **Int. Cl.⁷ A63B 21/02**

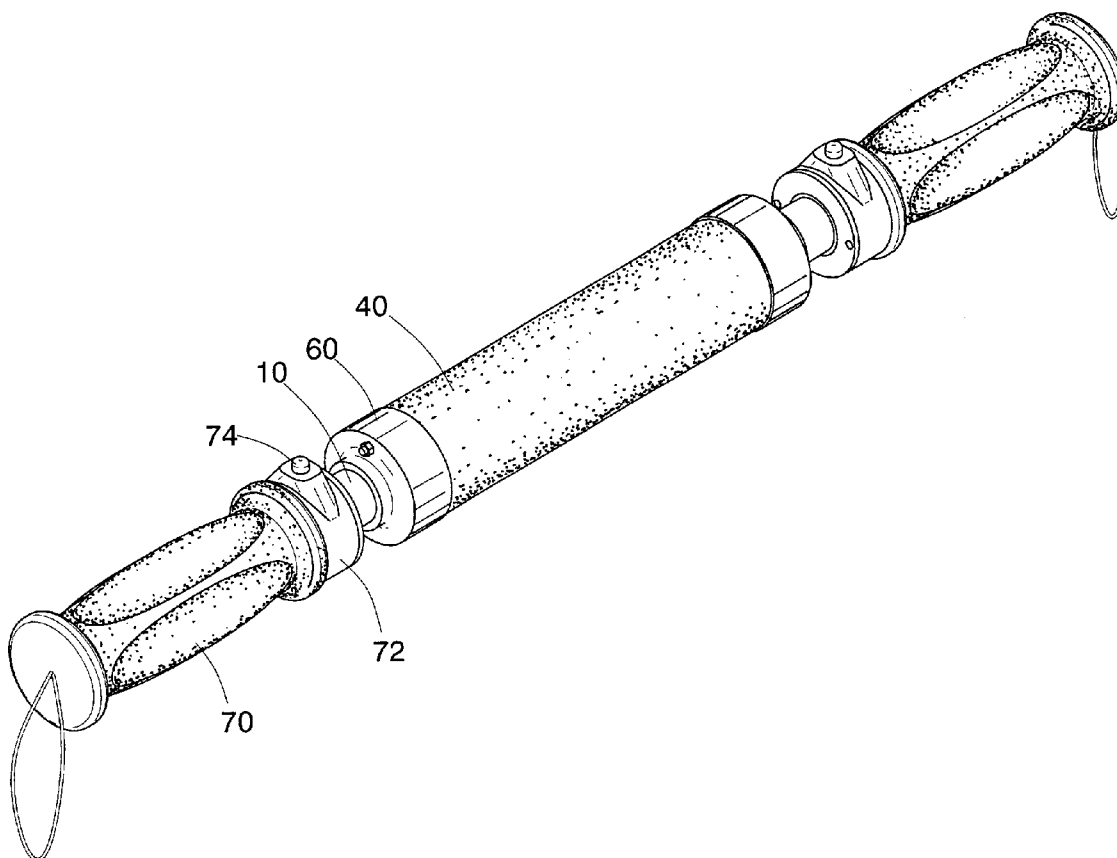

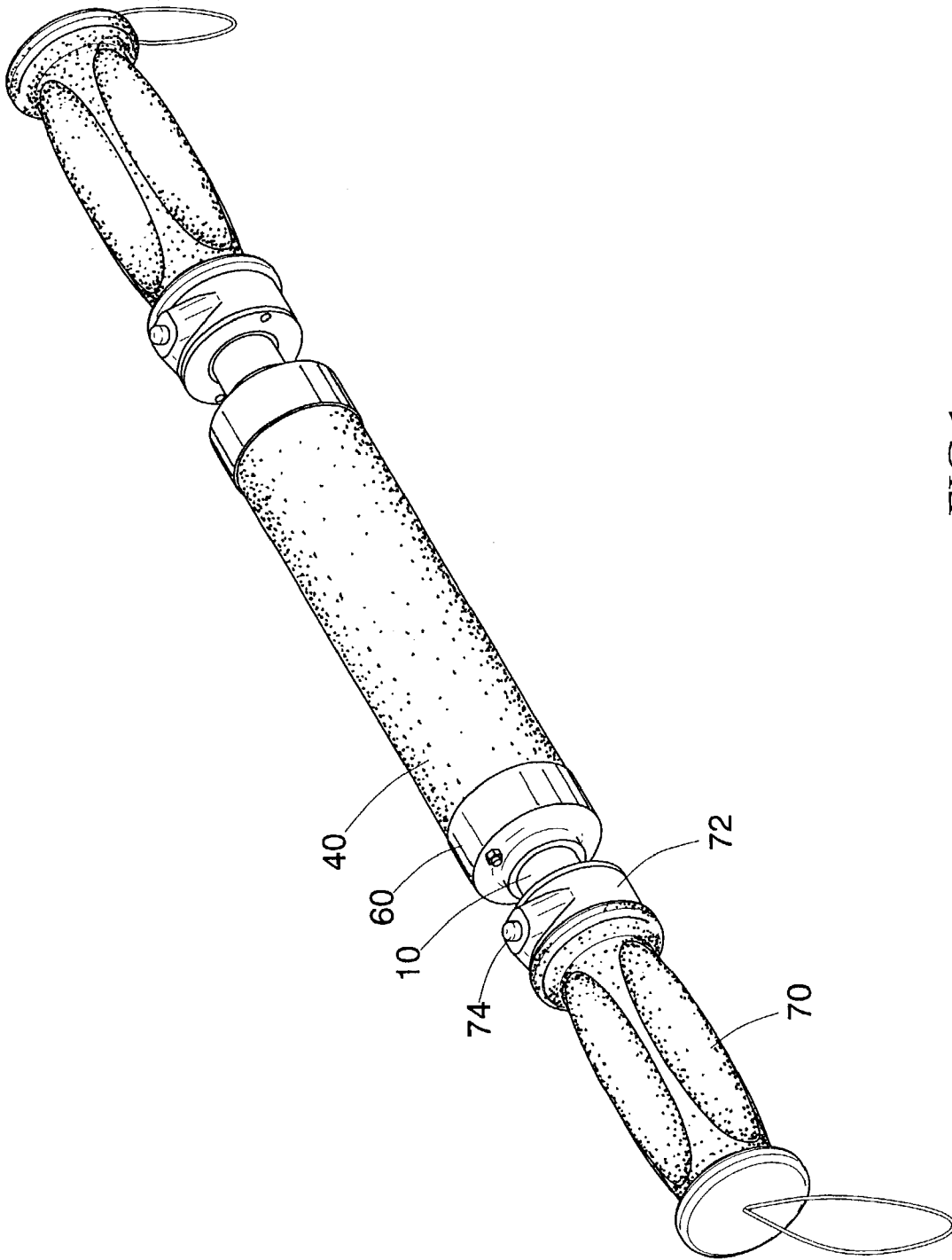

FIG.1

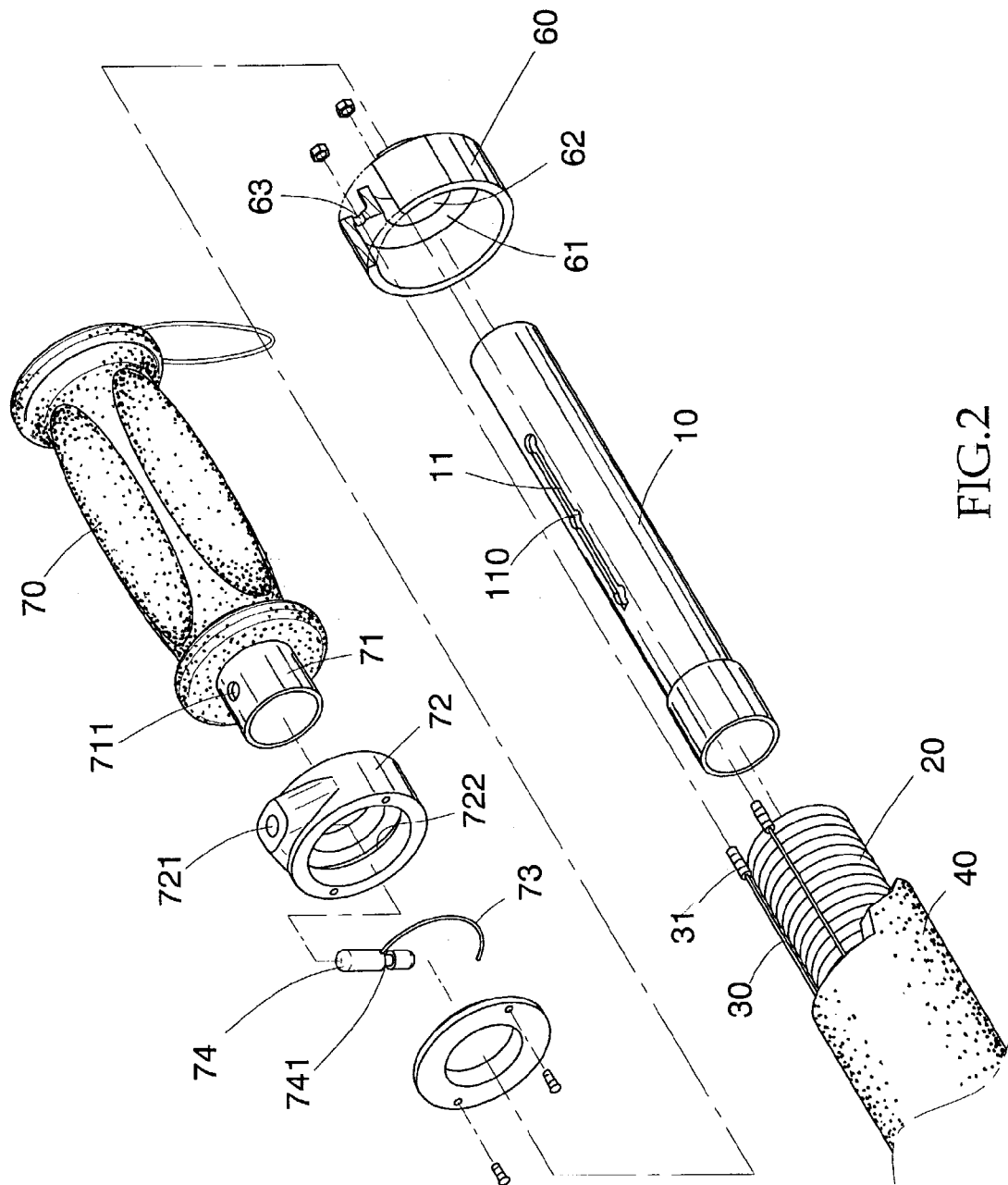

FIG. 2

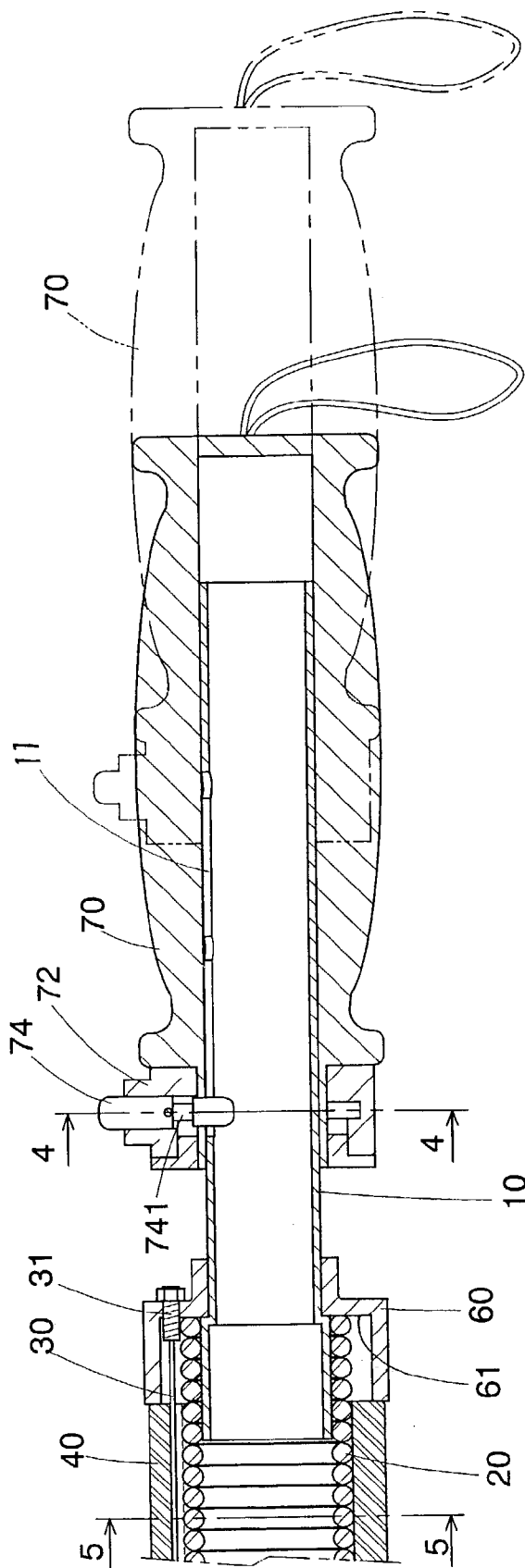

FIG.3

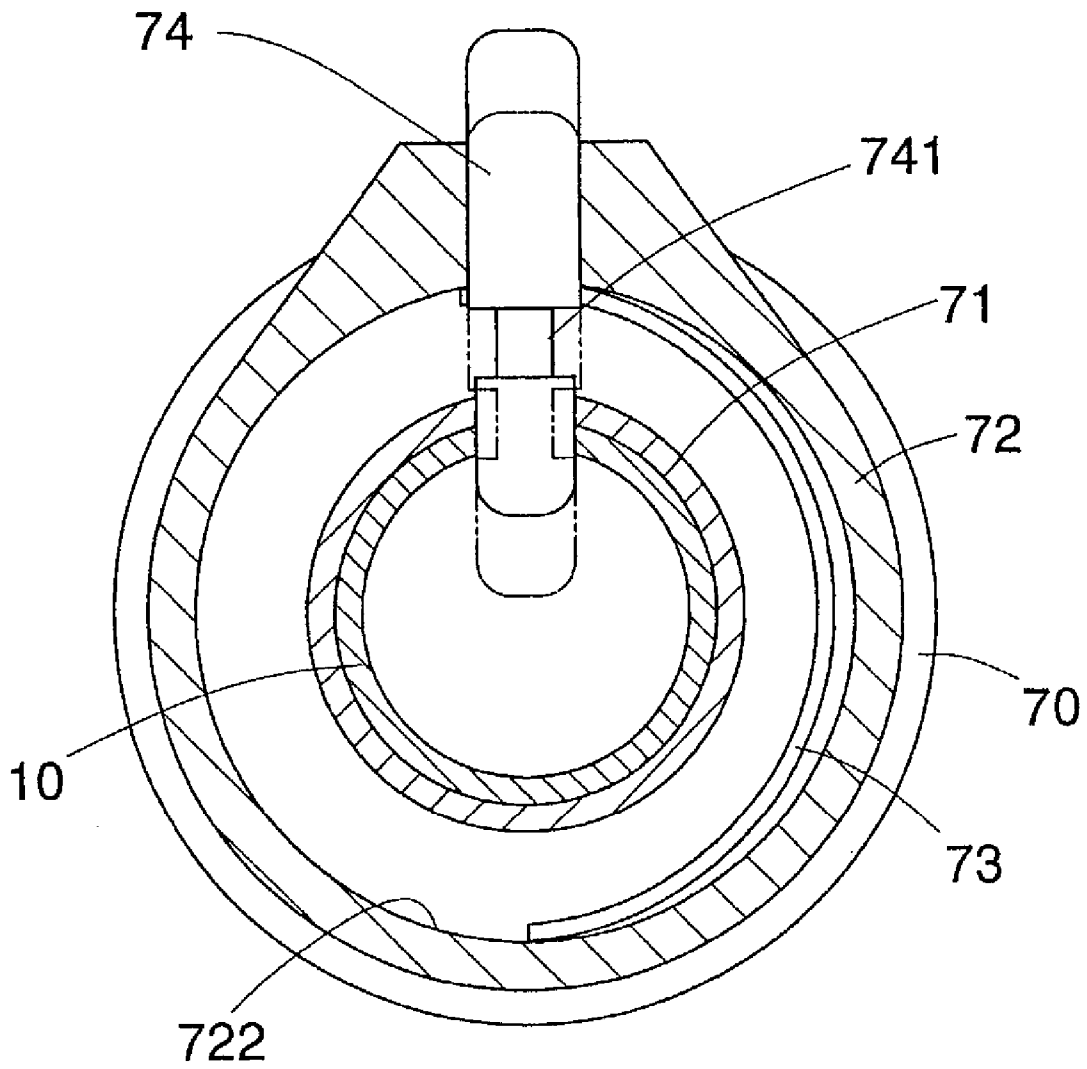

FIG.4

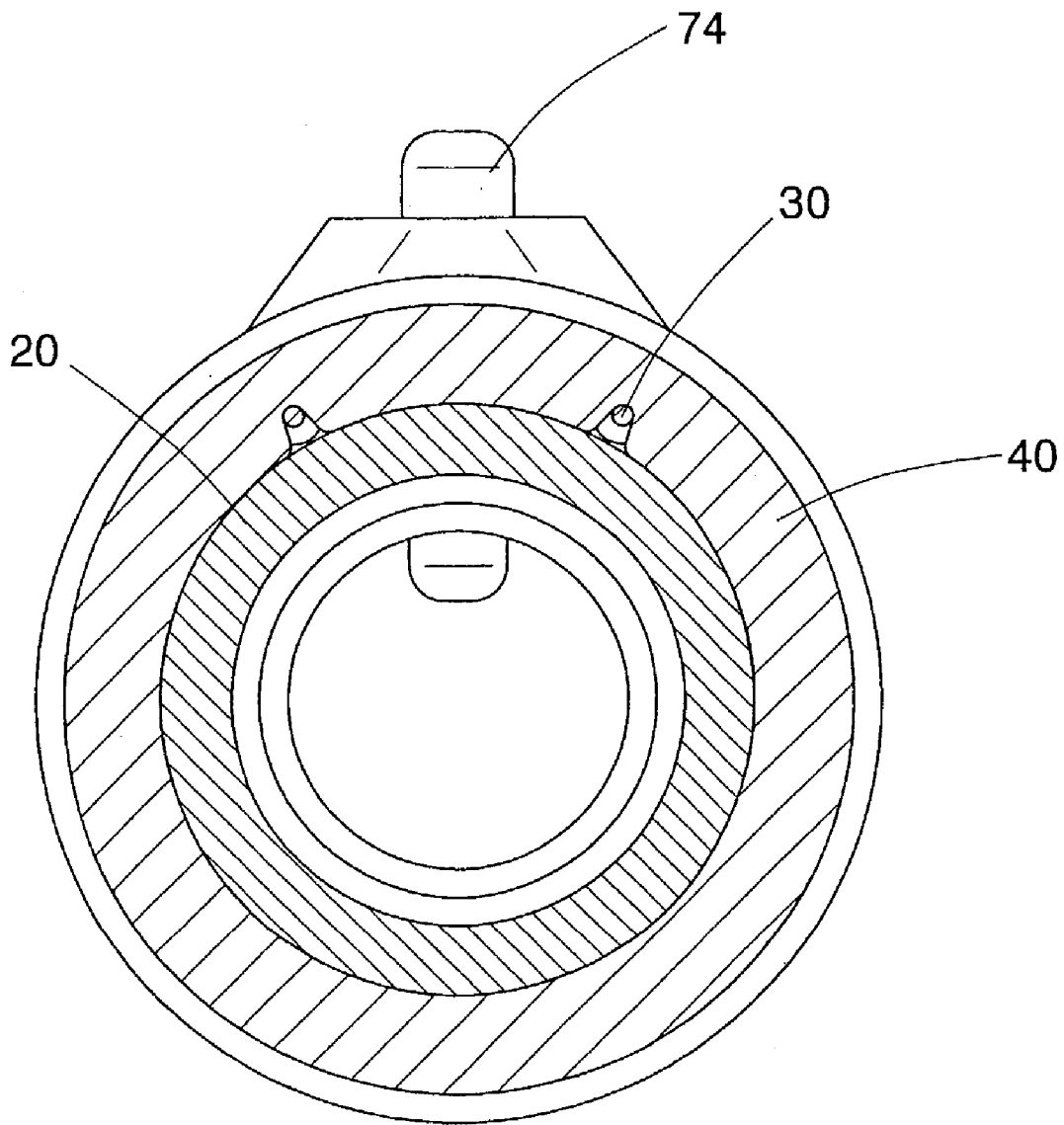

FIG.5

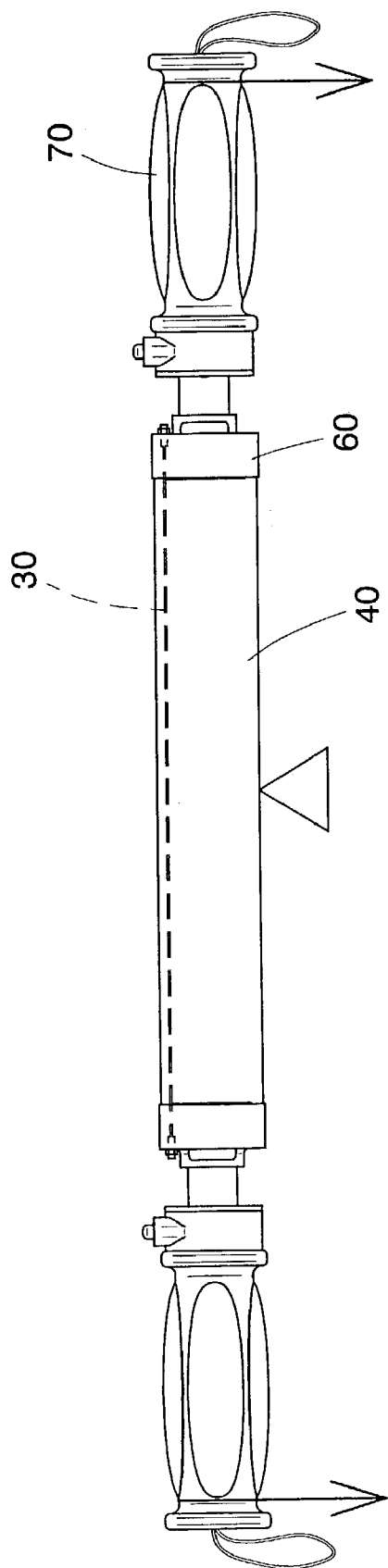

FIG.6

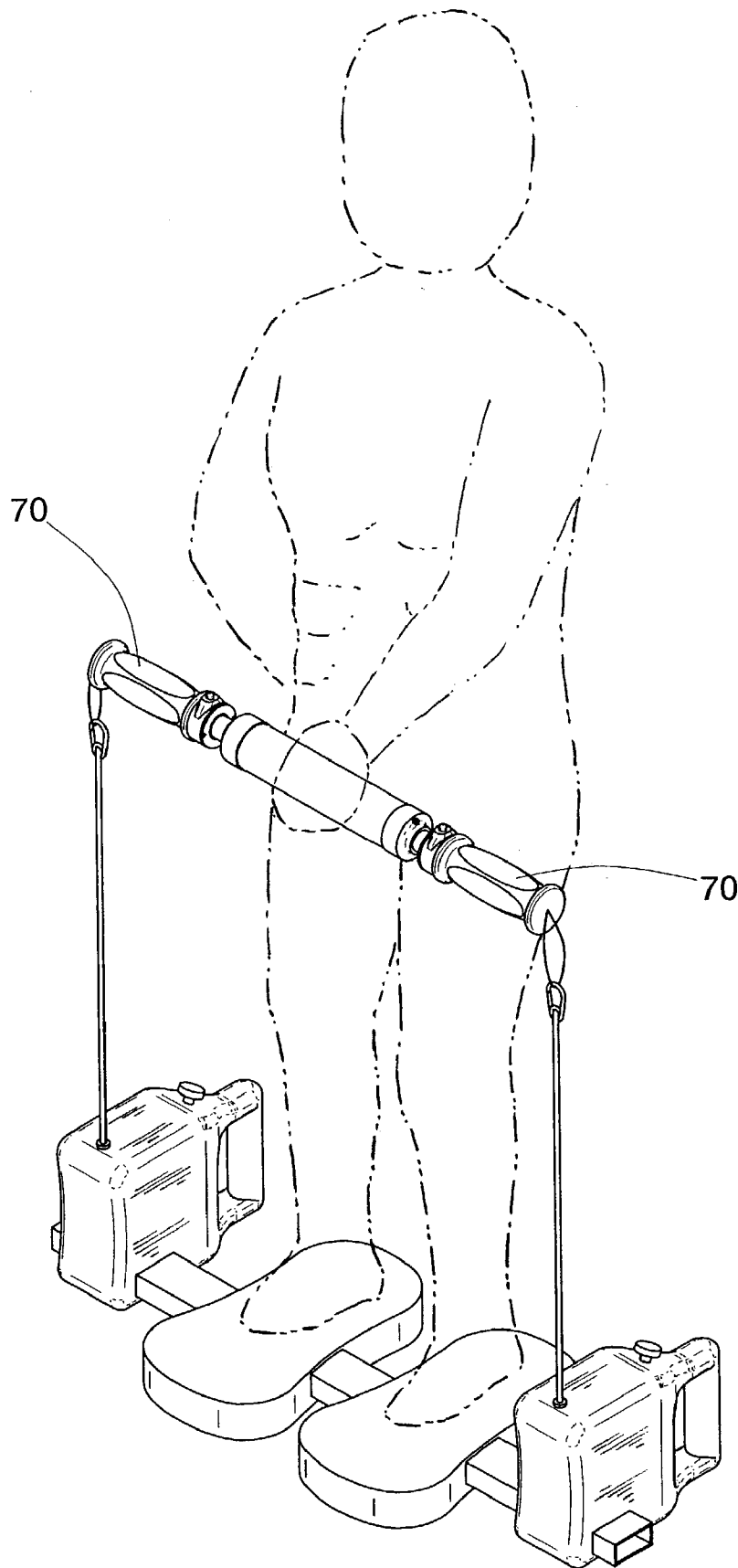
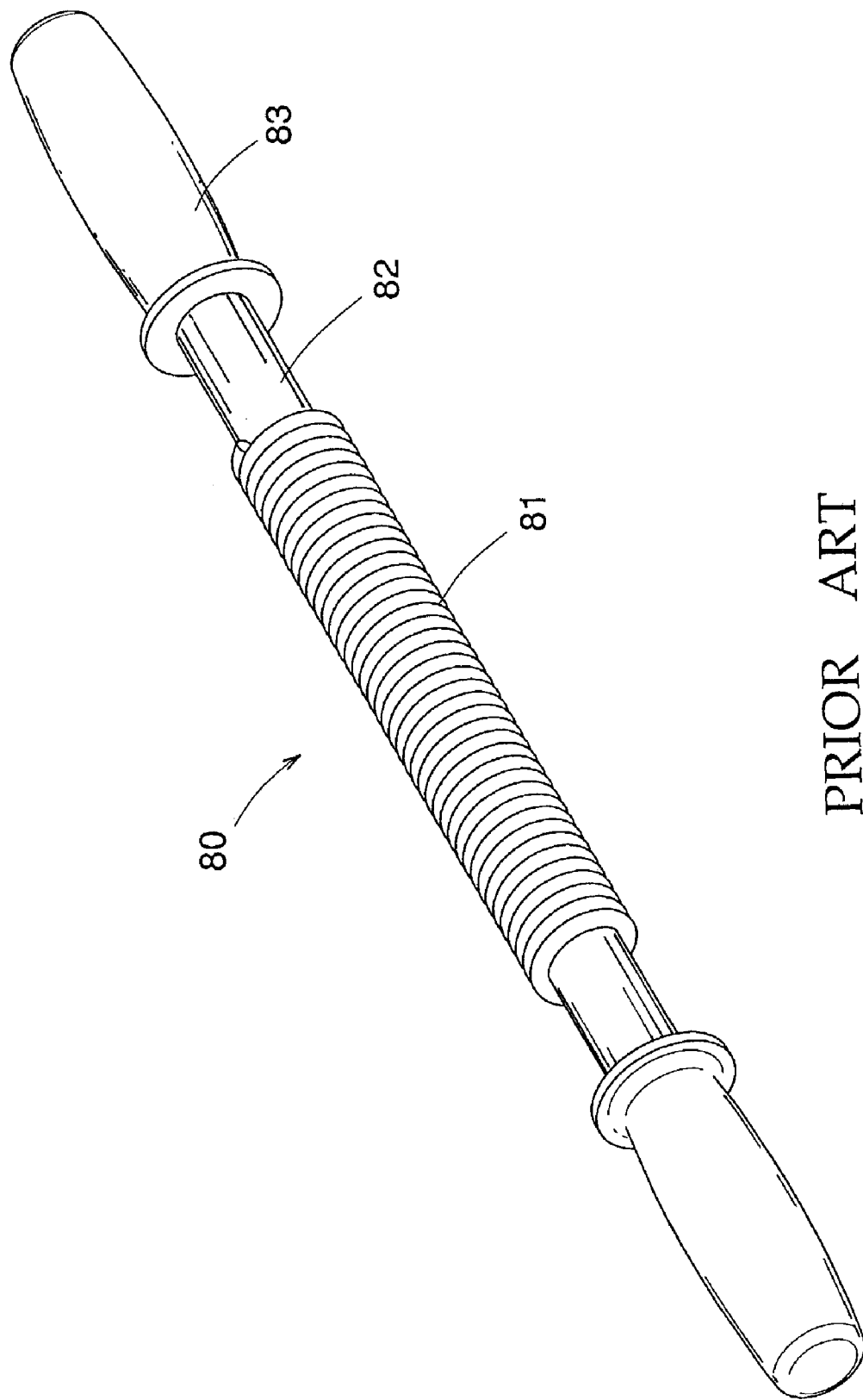

FIG. 7



PRIOR ART

FIG.8

ADJUSTABLE HANDLES FOR SPRING BARS

FIELD OF THE INVENTION

[0001] The present invention relates to an exercising device including a spring with two handles connected to two ends of the spring. The two handles can be moved relative to the spring so as to meet the users with different sizes.

BACKGROUND OF THE INVENTION

[0002] A conventional spring bar **80** is shown in **FIG. 8** and generally includes a spring **81** with two tubes **82** fixedly connected to two ends of the spring **81**. Each tube **82** is connected to a handle **83** such that the user may hold the two handles **83** and try to bend the spring **81** to exercise the muscles of the chest or arms according to the distance between the two handles **83**. The spring **81** is exposed without any protection so that when bending the spring bar **80** the gaps between the coils of the spring **81** could hurt the users especially the spring **81** is moved close to the body of the users when bending it. Besides, the length of the spring bar **80** cannot be adjusted so that it cannot be suitable for different users.

[0003] The present invention intends to provide a spring bar that has two adjustable handles so that the distance between the two handles can be adjusted to meet the needs of different users.

SUMMARY OF THE INVENTION

[0004] In accordance with one aspect of the present invention, there is provided a spring bar which comprises a spring and two cables are fixedly connected to an outside of the spring in a longitudinal direction of the spring. Each cable has two connection ends at two ends thereof. Two tubes are respectively connected to two ends of the spring and a slot is defined longitudinally through a wall of each of the tubes. A plurality of positioning recesses are defined in two insides defining the slot. Two end collars are respectively mounted to the two tubes and the two connection ends of each cable are fixedly connected to the two end collars.

[0005] Two handles each have an extension and a positioning hole is defined through each of the extensions. Two mounting collars are respectively mounted to the two extensions and a through hole is defined through each of the mounting collars. Two positioning members each have a spring member which is biased in the mounting collar corresponding thereto and each of which movably extends through the positioning hole and is inserted in the slot. An annular groove is defined in each of the positioning members and a width of the annular groove is larger than a thickness of the insides of the slot. The positioning members is positioned in one of the positioning recesses.

[0006] The present invention will become more obvious from the following description when taken in connection with the accompanying drawings which show, for purposes of illustration only, a preferred embodiment in accordance with the present invention.

BRIEF DESCRIPTION OF THE DRAWINGS

[0007] **FIG. 1** is a perspective view to show the spring bar of the present invention;

[0008] **FIG. 2** is an exploded view to show the spring bar of the present invention;

[0009] **FIG. 3** is a cross sectional view to show the spring bar of the present invention;

[0010] **FIG. 4** is an end cross sectional view to show the positioning members are pushed to allow the handles to be moved;

[0011] **FIG. 5** is an end cross sectional view to show the cables and the spring;

[0012] **FIG. 6** shows the two cables on the spring bar cannot be bent;

[0013] **FIG. 7** shows the spring bar is cooperated with other exercising devices; and

[0014] **FIG. 8** shows a conventional spring bar.

DETAILED DESCRIPTION OF THE PREFERRED EMBODIMENT

[0015] Referring to **FIGS. 1 to 3**, the spring bar of the present invention comprises a spring **20** with a coat **40** mounted an outside of the spring **20**. Two cables **30** are fixedly connected to an outside of the spring **20** in a longitudinal direction of the spring **20** and each cable **30** having two connection ends **31** at two ends thereof. An angle between the two cables **30** is 45 degrees relative to a center of the spring **20** as shown in **FIG. 5**.

[0016] Two tubes **10** are respectively connected to two ends of the spring **20** and a slot **11** is defined longitudinally through a wall of each of the tubes **10**. A plurality of positioning recesses **110** are defined in two insides defining the slot **11**.

[0017] Two end collars **60** each have a flange **61** extending inward from an end thereof and two holes **63** are defined through the flange **61**. Each end collars **60** are respectively mounted to the two tubes **10** which movably extend through two respective holes **62** of the two end collars **60**. The connection ends **31** of the cables **30** extend through the holes **63** and are secured by being connected with nuts.

[0018] Further referring to **FIG. 4**, two handles **70** each have an extension **71** and a positioning hole **711** is defined through each of the extensions **71**. Two mounting collars **72** are respectively mounted to the two extensions **71** and a through hole **721** is defined through each of the mounting collars **72**. A positioning groove **722** is defined in each of the two positioning members **72**. Two positioning members **74** each have a spring member **73** which is a C-shaped spring wire and engaged with the positioning groove **722** so as to bias the positioning member **74** outward. Each of the positioning members **74** movably extends through the positioning hole **711** and is inserted in the slot **11**. An annular groove **741** is defined in each of the positioning members **74** and a width of the annular groove **741** is larger than a thickness of the insides of the slot **11**. The positioning members **74** is positioned in one of the positioning recesses **110** by the biasing force from the spring member **73** and one of two ends of the annular grooves **741** is biased against the surface of the positioning recesses **110** to position the handles **70**.

[0019] When pushing the positioning members **74** downward, the handles **70** together with the tubes **10** can be pulled while the positioning members **74** are moved in the slots **11**.

The positioning members 74 are released to let one of the two ends of the annular grooves 741 is biased against the surface of another positioning recesses 110 again to position the handles 70. Therefore, the distance between the handles 70 can be adjusted according to needs.

[0020] Referring to FIG. 6, if the two cables 30 are arranged at top as shown and two forces are applied downward at the two handles 70, because the cables 30 cannot be extended so that the spring bar cannot be bent at this arrangement. The spring bar can be bent if the cables 30 are arranged at the underside position. Referring to FIG. 7, the spring bar can be cooperated with other devices and the spring bar is used as a solid bar to lift lards hanged on two handles 70.

[0021] While we have shown and described the embodiment in accordance with the present invention, it should be clear to those skilled in the art that further embodiments may be made without departing from the scope of the present invention.

What is claimed is:

1. A spring bar comprising:

a spring;

two cables fixedly connected to an outside of the spring in a longitudinal direction of the spring and each cable having two connection ends at two ends thereof;

two tubes respectively connected to two ends of the spring and a slot defined longitudinally through a wall of each of the tubes, a plurality of positioning recesses defined in two insides defining the slot;

two end collars respectively mounted to the two tubes which movably extend through two respective holes of

the two end collars, the two connection ends 31 of each cable 30 being fixedly connected to the two end collars 60;

two handles 70 each having an extension 71 and a positioning hole 711 defined through each of the extensions 71, two mounting collars 72 respectively mounted to the two extensions 71 and a through hole 721 defined through each of the mounting collars 72, and

two positioning members 74 each having a spring member 73 which is biased in the mounting collar 72 corresponding thereto, each of the positioning members 74 movably extending through the positioning hole 711 and inserted in the slot 11, an annular groove 741 defined in each of the positioning members 74 and a width of the annular groove 741 being larger than a thickness of the insides of the slot 11, the positioning members 74 being positioned in one of the positioning recesses 110.

2. The spring bar as claimed in claim 1, wherein the spring member is a C-shaped spring wire which is engaged with a positioning groove defined in each of the two positioning members.

3. The spring bar as claimed in claim 1, wherein the connection ends of the cables extend through holes defined through a flange extending inward from the end collars and are secured by being connected with nuts.

4. The spring bar as claimed in claim 1 wherein an angle between the two cables is 45 degrees relative to a center of the spring.

5. The spring bar as claimed in claim 1 further comprising a coat mounted an outside of the spring.

* * * * *